

REF30E and REF30, Low Current Voltage Reference in SOT-23-3

1 Features

- Small industry standard footprint: SOT23-3
- High accuracy
 - **REF30E: $\pm 0.1\%$**
 - REF30: $\pm 0.2\%$
- Excellent temperature drift performance:
 - **REF30E: 15ppm/°C**
 - REF30: 75ppm/°C
- **REF30E is drop-in replacement of REF30**
- Low I_Q (typical)
 - **REF30E: 27 μ A**
 - REF30: 42 μ A
- High output current
 - **REF30E: ± 10 mA**
 - REF30: 25mA
- Output voltage options
 - **REF30E: 1.25V to 5V**
 - REF30: 1.25V to 4.096V
- Temperature range: **-40°C to +125°C**

2 Applications

- [Field transmitter & sensor](#)
- [Solar energy](#)
- [PLC, DCS & PAC](#)
- [Energy storage systems](#)
- [Medical & healthcare](#)
- [AC inverter & VF drives](#)
- [Handheld Test Equipment](#)

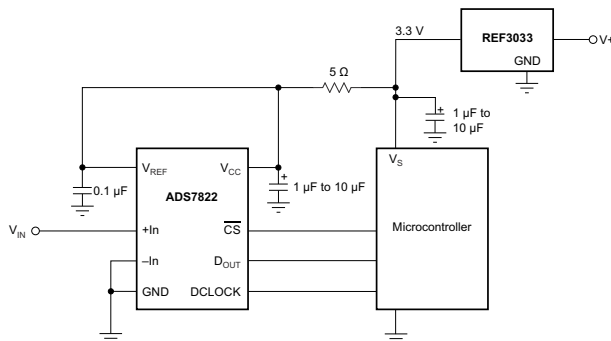

Typical Application

Copyright © 2016, Texas Instruments Incorporated

3 Description

The REF30 is a precision, low-power, low-dropout voltage, reference family available in a tiny 3-pin SOT-23 package. REF30E is the enhanced performance version of REF30 family which is designed for precision applications. The REF30E offers improved temperature drift and initial accuracy while operating at a lower quiescent current of 25 μ A.

The low power consumption and the improved precision make the REF30E very attractive for loop-powered industrial applications such as pressure and temperature transmitter and battery-powered applications. The REF30/REF30E is specified over the extended industrial temperature range of -40°C to +125°C. The REF30 is easy to use in intrinsically safe and explosion-proof applications because the REF30 does not require a load capacitor to be stable.

Package Information

PART NUMBER	PACKAGE ⁽¹⁾	PACKAGE SIZE ⁽²⁾
REF30xx	SOT-23 (3)	2.92mm × 2.37mm
REF30xxE	SOT-23 (3)	2.92mm × 2.37mm

- (1) For all available packages, see the orderable addendum at the end of the data sheet.
- (2) The package size (length × width) is a nominal value and includes pins, where applicable.

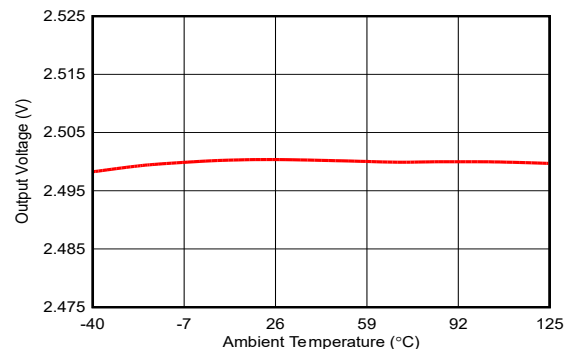

Output Voltage vs Temperature (REF3025E)



Table of Contents

1 Features	1	7.4 Device Functional Modes.....	21
2 Applications	1	8 Application and Implementation	23
3 Description	1	8.1 Application Information.....	23
4 Device Comparison Table	2	8.2 Typical Application.....	23
5 Pin Configuration and Functions	3	8.3 Power Supply Recommendations.....	25
6 Specifications	4	8.4 Layout.....	25
6.1 Absolute Maximum Ratings.....	4	9 Device and Documentation Support	26
6.2 ESD Ratings.....	4	9.1 Documentation Support.....	26
6.3 Recommended Operating Conditions.....	4	9.2 Related Links.....	26
6.4 Thermal Information.....	5	9.3 Receiving Notification of Documentation Updates.....	26
6.5 REF30E.....	5	9.4 Support Resources.....	26
6.6 REF30.....	8	9.5 Trademarks.....	26
6.7 Typical Characteristics REF30E.....	10	9.6 Electrostatic Discharge Caution.....	26
6.8 Typical Characteristics REF30.....	15	9.7 Glossary.....	26
7 Detailed Description	19	10 Revision History	27
7.1 Overview.....	19	11 Mechanical, Packaging, and Orderable Information	27
7.2 Functional Block Diagram.....	19		
7.3 Feature Description.....	19		

4 Device Comparison Table

Device Comparison

PRODUCT		Voltage
REF30	REF30E	
REF3012AIDBZR	REF3012EAIDBZR	1.25V
	REF3016EAIDBZR	1.65V
	REF3018EAIDBZR	1.8V
REF3020AIDBZR	REF3020EAIDBZR	2.048V
REF3025AIDBZR	REF3025EAIDBZR	2.5V
REF3030AIDBZR	REF3030EAIDBZR	3V
REF3033AIDBZR	REF3033EAIDBZR	3.3V
REF3040AIDBZR	REF3040EAIDBZR	4.096V
	REF3045EAIDBZR	4.5V
	REF3050EAIDBZR	5.0V

Specification comparison

PART NUMBER	Initial Accuracy(%)	Max Temperature Drift (ppm/°C)	IQ (µA)
REF30	±0.2	75 (–40°C to +125°C), 65 (–40°C to +125°C), 50 (0°C to 70°C)	42
REF30E	±0.1	15 (–40°C to +125°C), 20 (–40°C to +85°C), 15 (0°C to 70°C)	27

5 Pin Configuration and Functions

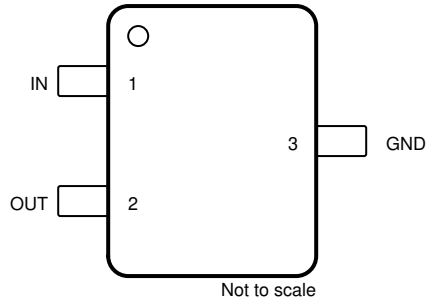

Figure 5-1. DBZ Package 3-Pin SOT-23 Top View

Table 5-1. Pin Functions

PIN		I/O	DESCRIPTION
NO.	NAME		
1	IN	Input	Input supply voltage
2	OUT	Output	Reference output voltage
3	GND	—	Ground

6 Specifications

6.1 Absolute Maximum Ratings

over operating free-air temperature range (unless otherwise noted)⁽¹⁾

		MIN	MAX	UNIT
Supply voltage, IN to GND	REF30xx		7	V
	REF30xxE		6	V
Output short-circuit current ⁽²⁾			70	mA
Operating temperature		-40	125	°C
Junction temperature (T _J max)			150	°C
Storage temperature range (T _{stg})		-65	150	°C

- (1) Stresses beyond those listed under Absolute Maximum Ratings can cause permanent damage to the device. These are stress ratings only, which do not imply functional operation of the device at these or any other conditions beyond those indicated under Recommended Operating Conditions. Exposure to absolute-maximum-rated conditions for extended periods can affect device reliability.
- (2) Short circuit to ground.

6.2 ESD Ratings

			VALUE	UNIT
V _(ESD)	Electrostatic discharge ⁽³⁾	Human body model (HBM), per ANSI/ESDA/JEDEC JS-001, all pins ⁽¹⁾	±4000	V
		Charged device model (CDM), per JEDEC specification JESD22-C101, all pins ⁽²⁾	±1500	
V _(ESD)	Electrostatic discharge ⁽⁴⁾	Human body model (HBM), per ANSI/ESDA/JEDEC JS-001, all pins ⁽¹⁾	±2000	
		Charged device model (CDM), per JEDEC specification JESD22-C101, all pins ⁽²⁾	±500	

- (1) JEDEC document JEP155 states that 500V HBM allows safe manufacturing with a standard ESD control process.
- (2) JEDEC document JEP157 states that 250V CDM allows safe manufacturing with a standard ESD control process.
- (3) Specification for REF30
- (4) Specification for REF30E

6.3 Recommended Operating Conditions

over operating free-air temperature range (unless otherwise noted)

		MIN	NOM	MAX	UNIT
V _{IN}	Input voltage ⁽²⁾	V _{OUT} + 0.05 ⁽¹⁾		5.5	V
V _{IN}	Input voltage ⁽³⁾	V _{OUT} + 0.2 ⁽¹⁾		5.75	V
I _{LOAD}	Load current ⁽²⁾			25	mA
I _{LOAD}	Load current ⁽³⁾	-10		10	mA
T _A	Operating temperature	-40		125	°C

- (1) For I_L > 0mA, see respective electrical table. Minimum supply voltage for REF3012, REF3012E AND REF3016E is 1.8V .
- (2) Specification for REF30xx
- (3) Specification for REF30xxE

6.4 Thermal Information

THERMAL METRIC ⁽¹⁾		REF30XX	REF30XXE	UNIT
		DBZ (SOT-23)	DBZ (SOT-23)	
		3 PINS	3 PINS	
R _{θJA}	Junction-to-ambient thermal resistance	297.3	218.5	°C/W
R _{θJC(top)}	Junction-to-case (top) thermal resistance	128.5	120.6	°C/W
R _{θJB}	Junction-to-board thermal resistance	91.7	48.7	°C/W
Ψ _{JT}	Junction-to-top characterization parameter	12.8	14.5	°C/W
Ψ _{JB}	Junction-to-board characterization parameter	90.3	48.2	°C/W
R _{θJC(bot)}	Junction-to-case (bottom) thermal resistance	N/A	N/A	°C/W

(1) For more information about traditional and new thermal metrics, see the [SPRA953](#) application report.

6.5 REF30E

at T_A = 25°C, V_{IN} = V_{OUT} + 300mV, C_{IN} = 0.1μF, C_{OUT} = 1μF and I_{LOAD} = 0mA (unless otherwise noted)

PARAMETER		TEST CONDITION	MIN	TYP	MAX	UNIT
REF3012E (1.25V)⁽¹⁾						
V _{OUT}	Output Voltage		1.24875	1.25	1.25125	V
	Initial accuracy		-0.1		0.1	%
	Output voltage noise	f = 0.1Hz to 10Hz		10		μV _{PP}
		f = 10Hz to 10kHz		31		μV _{rms}
	Line regulation	1.8V ≤ V _{IN} ≤ 5.75V		4	100	μV/V
REF3016E (1.65V)⁽¹⁾						
V _{OUT}	Output Voltage		1.64835	1.65	1.65165	V
	Initial accuracy		-0.1		0.1	%
	Output voltage noise	f = 0.1Hz to 10Hz		13		μV _{PP}
		f = 10Hz to 10kHz		35		μV _{rms}
	Line regulation	1.8V ≤ V _{IN} ≤ 5.75V		10	110	μV/V
REF3018E (1.8V)						
V _{OUT}	Output Voltage		1.7982	1.8	1.8018	V
	Initial accuracy		-0.1		0.1	%
	Output voltage noise	f = 0.1Hz to 10Hz		14		μV _{PP}
		f = 10Hz to 10kHz		37		μV _{rms}
	Line regulation	V _{OUT} + 300mV ≤ V _{IN} ≤ 5.75V		11	125	μV/V
REF3020E (2.048V)						
V _{OUT}	Output Voltage		2.045952	2.048	2.050048	V
	Initial accuracy		-0.1		0.1	%
	Output voltage noise	f = 0.1Hz to 10Hz		16		μV _{PP}
		f = 10Hz to 10kHz		40		μV _{rms}
	Line regulation	V _{OUT} + 300mV ≤ V _{IN} ≤ 5.75V		12	150	μV/V
REF3025E (2.5V)						
V _{OUT}	Output Voltage		2.4975	2.5	2.5025	V
	Initial accuracy		-0.1		0.1	%
	Output voltage noise	f = 0.1Hz to 10Hz		20		μV _{PP}
		f = 10Hz to 10kHz		46		μV _{rms}
	Line regulation	V _{OUT} + 300mV ≤ V _{IN} ≤ 5.75V		13	200	μV/V

6.5 REF30E (continued)

 at $T_A = 25^\circ\text{C}$, $V_{IN} = V_{OUT} + 300\text{mV}$, $C_{IN} = 0.1\mu\text{F}$, $C_{OUT} = 1\mu\text{F}$ and $I_{LOAD} = 0\text{mA}$ (unless otherwise noted)

PARAMETER		TEST CONDITION	MIN	TYP	MAX	UNIT
REF3030E (3.0V)						
V_{OUT}	Output Voltage		2.997	3	3.003	V
	Initial accuracy		-0.1		0.1	%
	Output voltage noise	$f = 0.1\text{Hz to }10\text{Hz}$		24		μV_{PP}
		$f = 10\text{Hz to }10\text{kHz}$		51		μV_{rms}
	Line regulation	$V_{OUT} + 300\text{mV} \leq V_{IN} \leq 5.75\text{V}$		16	240	$\mu\text{V}/\text{V}$
REF3033E (3.3V)						
V_{OUT}	Output Voltage		3.2967	3.3	3.3033	V
	Initial accuracy		-0.1		0.1	%
	Output voltage noise	$f = 0.1\text{Hz to }10\text{Hz}$		26		μV_{PP}
		$f = 10\text{Hz to }10\text{kHz}$		54		μV_{rms}
	Line regulation	$V_{OUT} + 300\text{mV} \leq V_{IN} \leq 5.75\text{V}$		18	260	$\mu\text{V}/\text{V}$
REF3040E (4.096V)						
V_{OUT}	Output Voltage		4.091904	4.096	4.100096	V
	Initial accuracy		-0.1		0.1	%
	Output voltage noise	$f = 0.1\text{Hz to }10\text{Hz}$		33		μV_{PP}
	Output voltage noise	$f = 10\text{Hz to }10\text{kHz}$		62		μV_{rms}
	Line regulation	$V_{OUT} + 300\text{mV} \leq V_{IN} \leq 5.75\text{V}$		29	300	$\mu\text{V}/\text{V}$
REF3045E(4.5V)						
V_{OUT}	Output Voltage		4.4955	4.5	4.5045	V
	Initial accuracy		-0.1		0.1	%
	Output voltage noise	$f = 0.1\text{Hz to }10\text{Hz}$		36		μV_{PP}
		$f = 10\text{Hz to }10\text{kHz}$		66		μV_{rms}
	Line regulation	$V_{OUT} + 300\text{mV} \leq V_{IN} \leq 5.75\text{V}$		41	350	$\mu\text{V}/\text{V}$
REF3050E (5.0V)						
V_{OUT}	Output Voltage		4.995	5	5.005	V
	Initial accuracy		-0.1		0.1	%
	Output voltage noise	$f = 0.1\text{Hz to }10\text{Hz}$		40		μV_{PP}
		$f = 10\text{Hz to }10\text{kHz}$		70		μV_{rms}
	Line regulation	$V_{OUT} + 300\text{mV} \leq V_{IN} \leq 5.75\text{V}$		87	600	$\mu\text{V}/\text{V}$

6.5 REF30E (continued)

at $T_A = 25^\circ\text{C}$, $V_{IN} = V_{OUT} + 300\text{mV}$, $C_{IN} = 0.1\mu\text{F}$, $C_{OUT} = 1\mu\text{F}$ and $I_{LOAD} = 0\text{mA}$ (unless otherwise noted)

PARAMETER		TEST CONDITION	MIN	TYP	MAX	UNIT
REF30xxE						
dV_{OUT}/dT	Output voltage temperature ⁽²⁾	$0^\circ\text{C} \leq T_A \leq 70^\circ\text{C}$		5	15	ppm/ $^\circ\text{C}$
		$-40^\circ\text{C} \leq T_A \leq 85^\circ\text{C}$		6	20	
		$-40^\circ\text{C} \leq T_A \leq 125^\circ\text{C}$		5	15	
	Long Term stability	0000h to 1000h		40		ppm
		1000h to 2000h		15		
dV_{OUT}/dI_{LOAD}	Load regulation Source	$0\text{mA} < I_{LOAD} < 10\text{mA}$, $V_{IN} = V_{OUT} + 500\text{mV}$		3	15	ppm/mA
	Load regulation Sink	$0\text{mA} > I_{LOAD} > -10\text{mA}$, $V_{IN} = V_{OUT} + 500\text{mV}$		3	150	ppm/mA
V_{DO}	Dropout voltage ⁽¹⁾			20	200	mV
I_{SC}	Short-circuit current			35		mA
	Turnon settling time	To 0.1% with $C_L = 1\mu\text{F}$		2		ms
POWER SUPPLY						
I_Q	Quiescent current	$T_A = 25^\circ\text{C}$		27		μA
		$-40^\circ\text{C} \leq T_A \leq 125^\circ\text{C}$			37	
CAPACITIVE LOAD						
C_{IN}	Stable input capacitor range	$-40^\circ\text{C} \leq T_A \leq 125^\circ\text{C}$		0.1		μF
C_L	Stable output capacitor range ⁽³⁾	$-40^\circ\text{C} \leq T_A \leq 125^\circ\text{C}$		0.1	22	μF

(1) The minimum supply voltage for the REF3012E and REF3016E is 1.8V.

(2) Box method used to determine over temperature drift.

(3) ESR for the capacitor can range from 10m Ω to 500m Ω .

6.6 REF30

 at $T_A = 25^\circ\text{C}$, $V_{IN} = 5\text{V}$, and $I_{LOAD} = 0\text{mA}$ (unless otherwise noted)

PARAMETER		TEST CONDITION	MIN	TYP	MAX	UNIT
REF3012 (1.25V)⁽¹⁾						
V_{OUT}	Output Voltage		1.2475	1.25	1.2525	V
	Initial accuracy				0.2	%
	Output voltage noise	$f = 10\text{Hz to } 1\text{kHz}$		14		μV_{PP}
		$f = 10\text{Hz to } 10\text{kHz}$		42		μV_{rms}
	Line regulation	$1.8\text{V} \leq V_{IN} \leq 5.5\text{V}$		60	190	$\mu\text{V}/\text{V}$
REF3020 (2.048V)						
V_{OUT}	Output Voltage		2.044	2.048	2.052	V
	Initial accuracy				0.2	%
	Output voltage noise	$f = 10\text{Hz to } 1\text{kHz}$		23		μV_{PP}
		$f = 10\text{Hz to } 10\text{kHz}$			65	
	Line regulation	$V_{REF} + 50\text{mV} \leq V_{IN} \leq 5.5\text{V}$		110	290	$\mu\text{V}/\text{V}$
REF3025 (2.5V)						
V_{OUT}	Output Voltage		2.495	2.5	2.505	V
	Initial accuracy				0.2	%
	Output voltage noise	$f = 10\text{Hz to } 1\text{kHz}$		28		μV_{PP}
		$f = 10\text{Hz to } 10\text{kHz}$			80	
	Line regulation	$V_{REF} + 50\text{mV} \leq V_{IN} \leq 5.5\text{V}$		120	325	$\mu\text{V}/\text{V}$
REF3030 (3.0V)						
V_{OUT}	Output Voltage		2.994	3	3.06	V
	Initial accuracy				0.2	%
	Output voltage noise	$f = 10\text{Hz to } 1\text{kHz}$		33		μV_{PP}
		$f = 10\text{Hz to } 10\text{kHz}$			94	
	Line regulation	$V_{REF} + 50\text{mV} \leq V_{IN} \leq 5.5\text{V}$		120	375	$\mu\text{V}/\text{V}$
REF3033 (3.3V)						
V_{OUT}	Output Voltage		3.294	3.3	3.306	V
	Initial accuracy				0.2	%
	Output voltage noise	$f = 10\text{Hz to } 1\text{kHz}$		36		μV_{PP}
		$f = 10\text{Hz to } 10\text{kHz}$			105	
	Line regulation	$V_{REF} + 50\text{mV} \leq V_{IN} \leq 5.5\text{V}$		130	400	$\mu\text{V}/\text{V}$
REF3040 (4.096V)						
V_{OUT}	Output Voltage		4.088	4.096	4.104	V
	Initial accuracy				0.2	%
	Output voltage noise	$f = 10\text{Hz to } 1\text{kHz}$		45		μV_{PP}
		$f = 10\text{Hz to } 10\text{kHz}$			128	
	Line regulation	$V_{REF} + 50\text{mV} \leq V_{IN} \leq 5.5\text{V}$		160	410	$\mu\text{V}/\text{V}$

6.6 REF30 (continued)

 at $T_A = 25^\circ\text{C}$, $V_{IN} = 5\text{V}$, and $I_{LOAD} = 0\text{mA}$ (unless otherwise noted)

PARAMETER		TEST CONDITION	MIN	TYP	MAX	UNIT
REF30xx						
dV_{OUT}/dT	Output voltage temperature drift ⁽²⁾	$0^\circ\text{C} \leq T_A \leq 70^\circ\text{C}$		20	50	ppm/ $^\circ\text{C}$
		$-30^\circ\text{C} \leq T_A \leq +85^\circ\text{C}$		28	60	
		$-40^\circ\text{C} \leq T_A \leq +85^\circ\text{C}$		30	65	
		$-40^\circ\text{C} \leq T_A \leq +125^\circ\text{C}$		35	75	
dV_{OUT}/dI_{LOAD}	Load regulation ⁽³⁾	$0\text{mA} < I_{LOAD} < 25\text{mA}$, $V_{IN} = V_{REF} + 500\text{mV}$ ⁽¹⁾		3	100	ppm
			Thermal hysteresis ⁽⁴⁾		25	100
	Long Term stability	0000h to 1000h		24		ppm
		1000h to 2000h		15		
V_{DO}	Dropout voltage			1	50	mV
I_{SC}	Short-circuit current			45		mA
	Turnon settling time	To 0.1% with $C_L = 1\mu\text{F}$		120		μs
POWER SUPPLY						
I_Q	Quiescent current	$T_A = 25\text{C}$		42	50	μA
		$-40^\circ\text{C} \leq T_A \leq +125^\circ\text{C}$			59	

- (1) The minimum supply voltage for the REF3012 is 1.8V.
- (2) Box method used to determine over temperature drift.
- (3) Typical value of load regulation reflects measurements using a force and sense contacts see Section 8.3.6 section.
- (4) Thermal hysteresis procedure explained in more detail in Section 8.3.2 section.

6.7 Typical Characteristics REF30E

at $T_A = 25^\circ\text{C}$, $V_{IN} = 5\text{V}$, and REF3050E used for typical characteristics (unless otherwise noted).

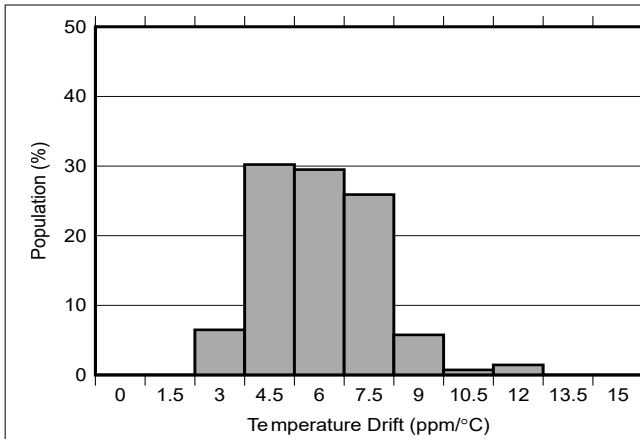

Figure 6-1. Temperature Drift Histogram -40°C to +125°C

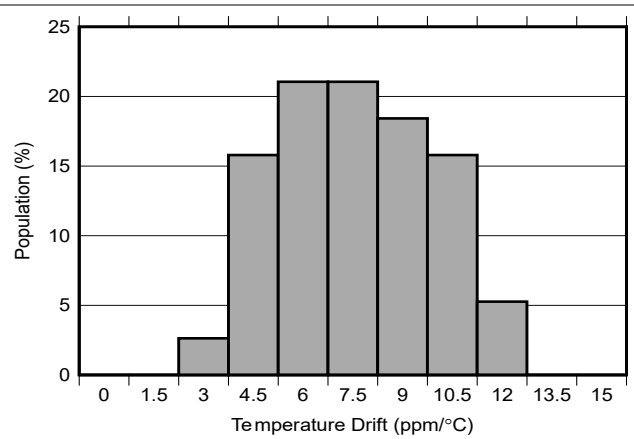

Figure 6-2. Temperature Drift Histogram -40°C to +85°C

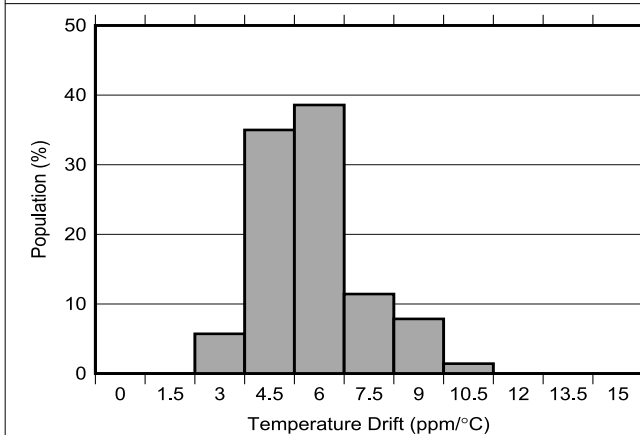

Figure 6-3. Temperature Drift Histogram 0°C to +70°C

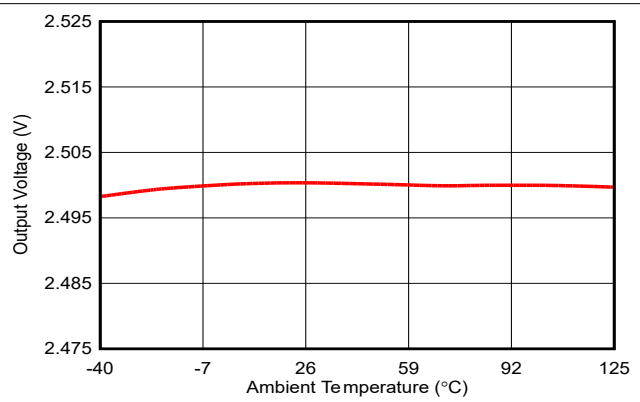

Figure 6-4. Output Voltage vs Temperature $V_{OUT} = 2.5\text{V}$

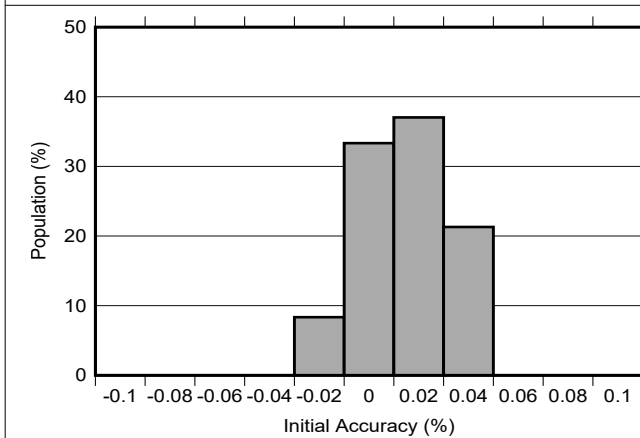

Figure 6-5. Initial Accuracy

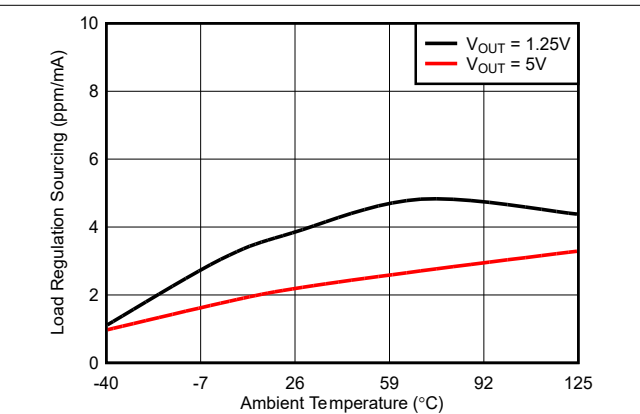
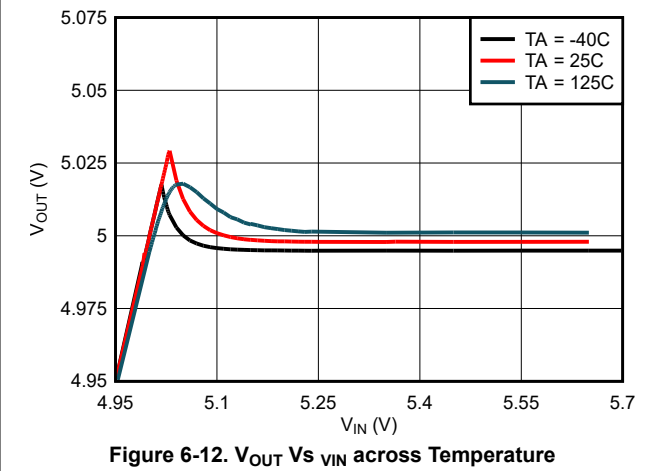
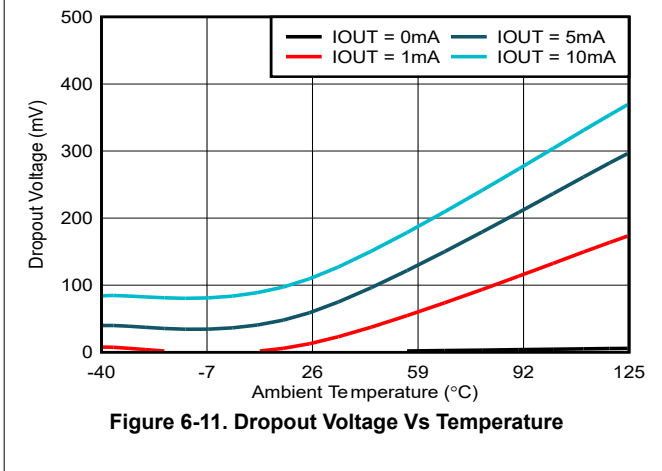
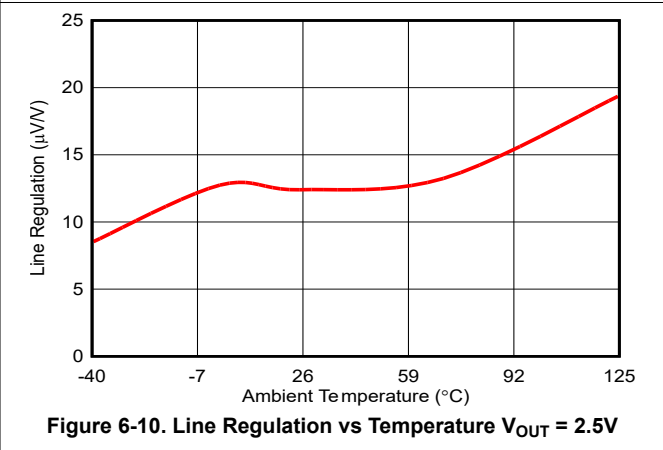
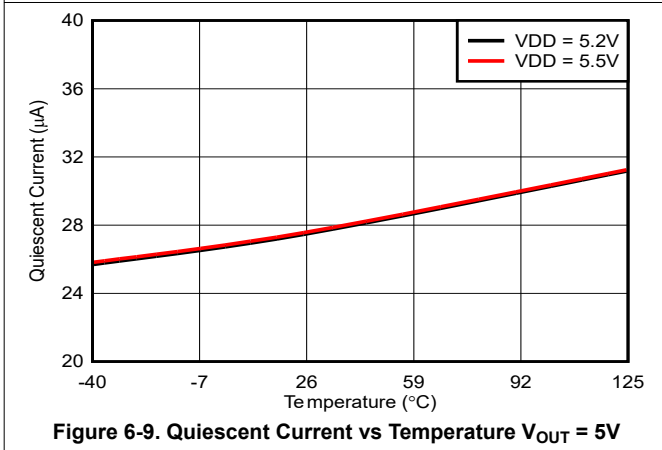
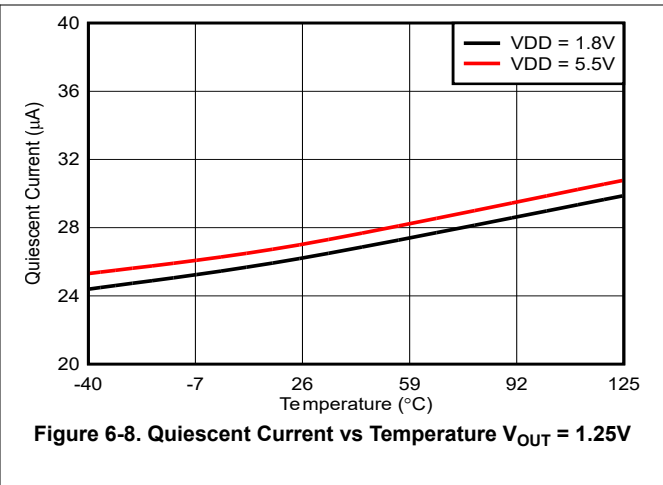
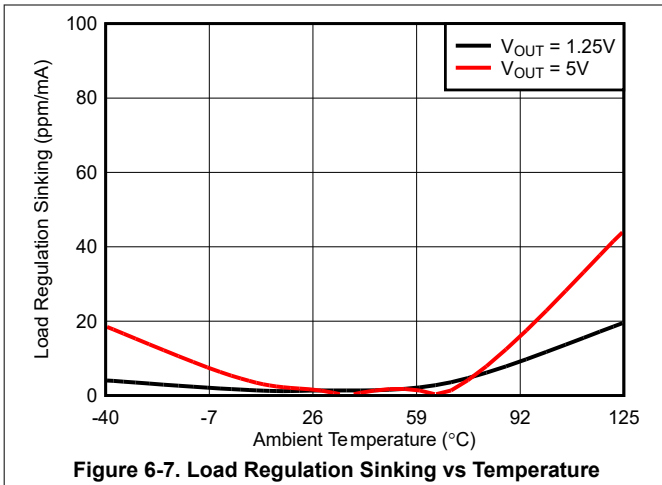

Figure 6-6. Load Regulation Sourcing vs Temperature

6.7 Typical Characteristics REF30E (continued)

at $T_A = 25^\circ\text{C}$, $V_{IN} = 5\text{V}$, and REF3050E used for typical characteristics (unless otherwise noted).



6.7 Typical Characteristics REF30E (continued)

at $T_A = 25^\circ\text{C}$, $V_{IN} = 5\text{V}$, and REF3050E used for typical characteristics (unless otherwise noted).

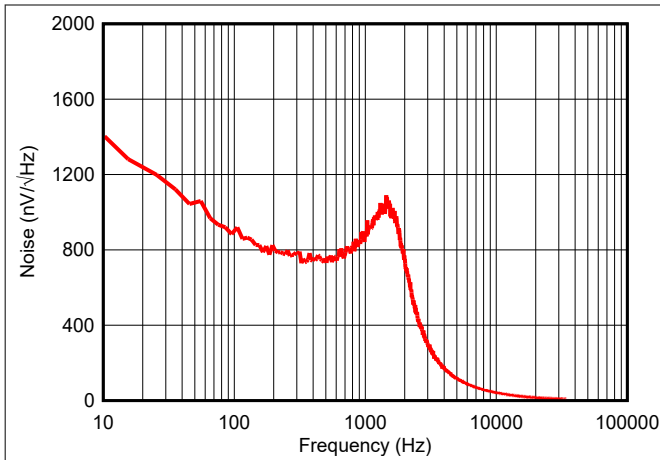

Figure 6-13. Noise Spectral Density vs Frequency

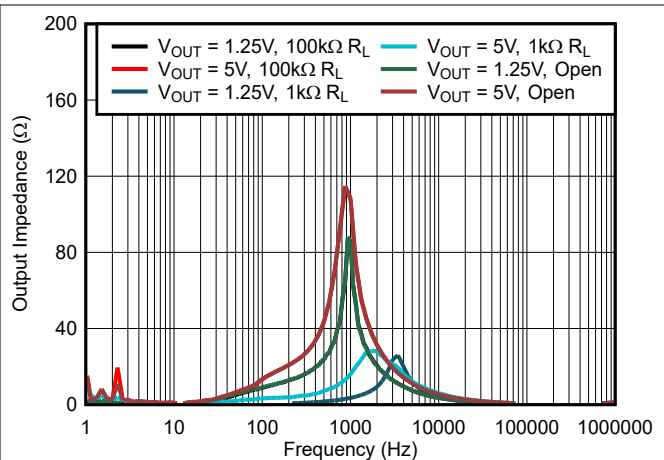

Figure 6-14. Output Impedance vs Frequency

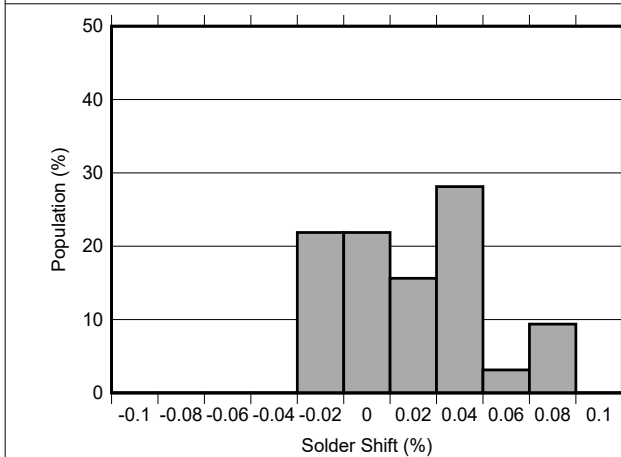

Figure 6-15. Solder Shift Histogram

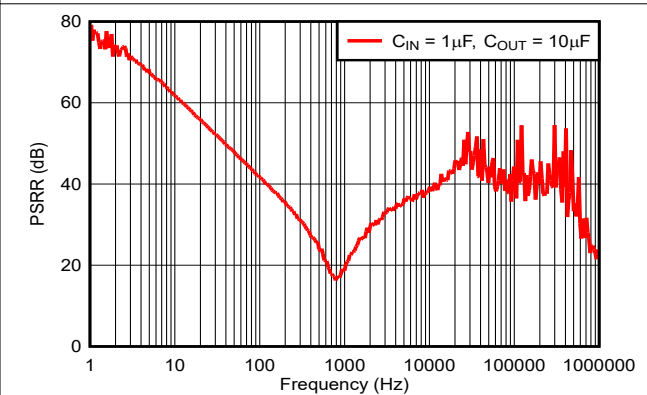

Figure 6-16. Power-Supply Rejection Ratio vs Frequency

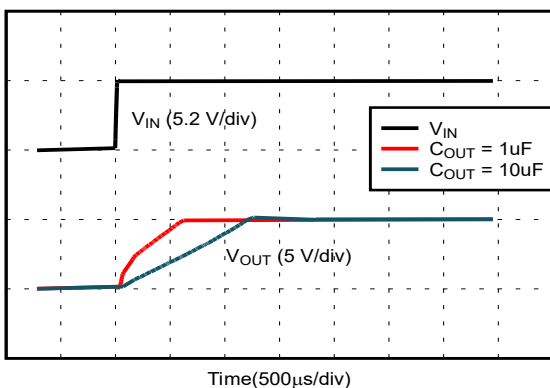

Figure 6-17. Step Response startup

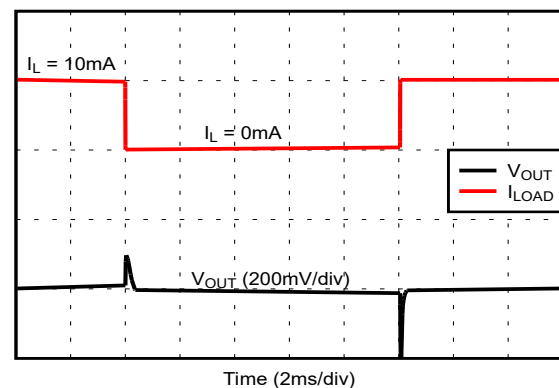

Figure 6-18. Load Transient Response (Sourcing Current)

6.7 Typical Characteristics REF30E (continued)

at $T_A = 25^\circ\text{C}$, $V_{IN} = 5\text{V}$, and REF3050E used for typical characteristics (unless otherwise noted).

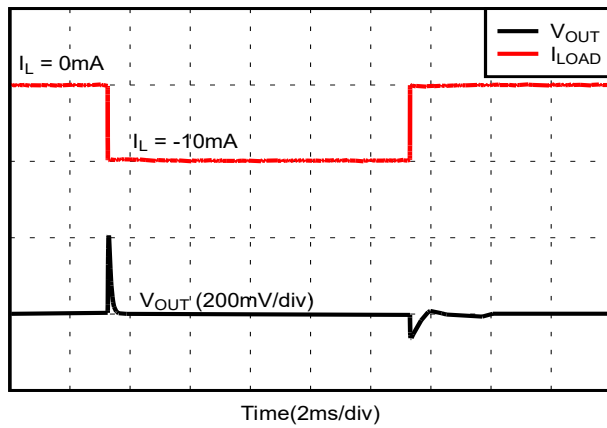

Figure 6-19. Load Transient Response (Sinking Current)

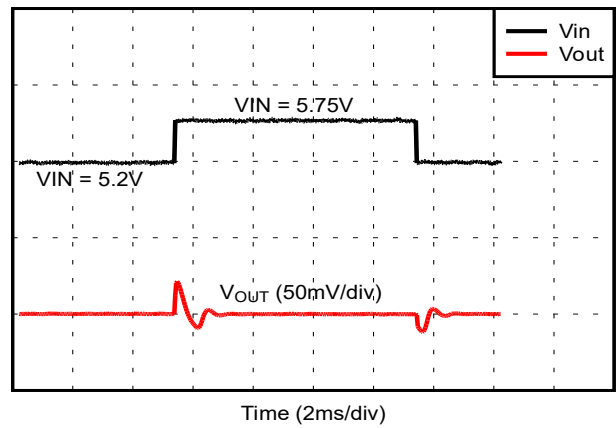

Figure 6-20. Line Transient Response

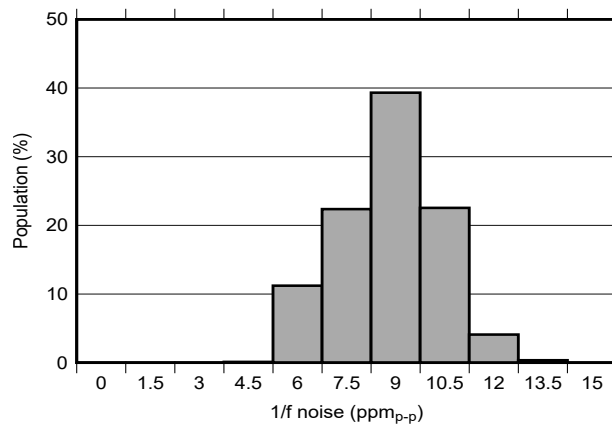

Figure 6-21. Flicker Noise Histogram

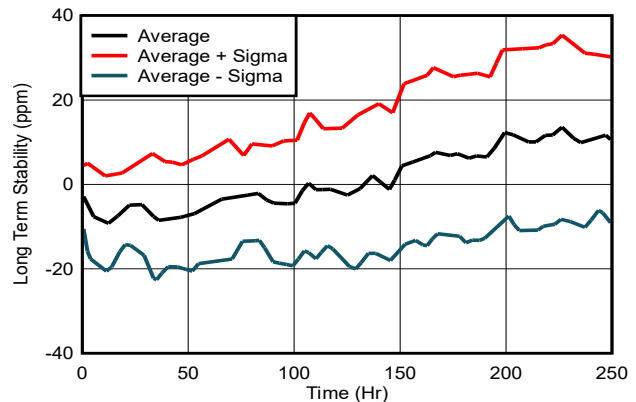

Figure 6-22. Long-Term Stability: 0 to 250 Hours

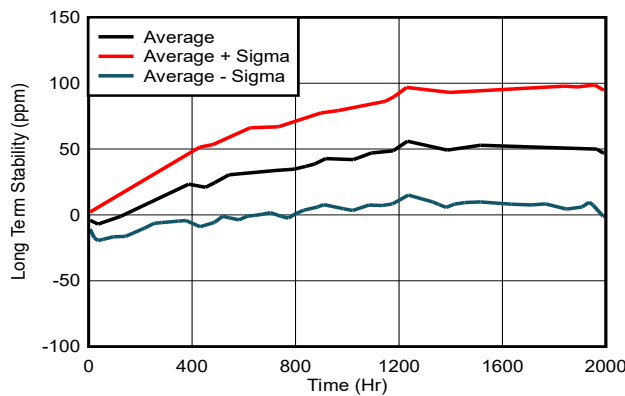

Figure 6-23. Long-Term Stability: 0 to 2000 Hours

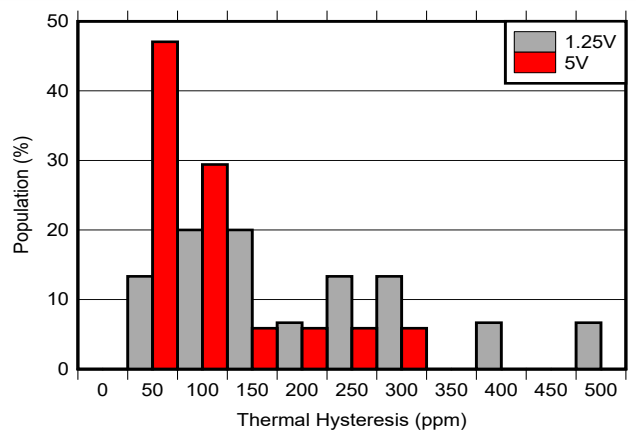

Figure 6-24. Thermal Hysteresis Histogram -40°C to 125°C Cycle 1

6.7 Typical Characteristics REF30E (continued)

at $T_A = 25^\circ\text{C}$, $V_{IN} = 5\text{V}$, and REF3050E used for typical characteristics (unless otherwise noted).

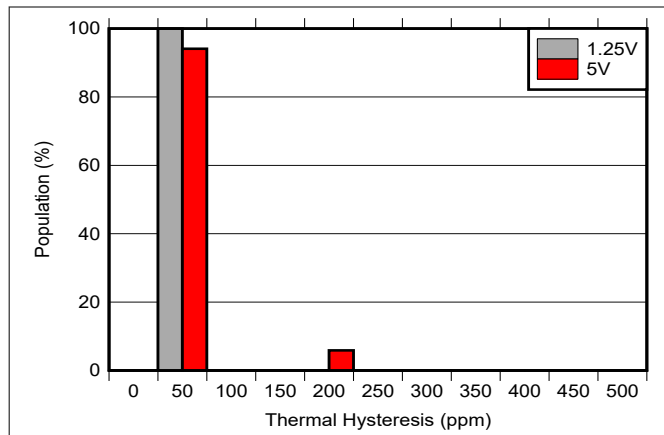

Figure 6-25. Thermal Hysteresis Histogram -40°C to 125°C Cycle 2

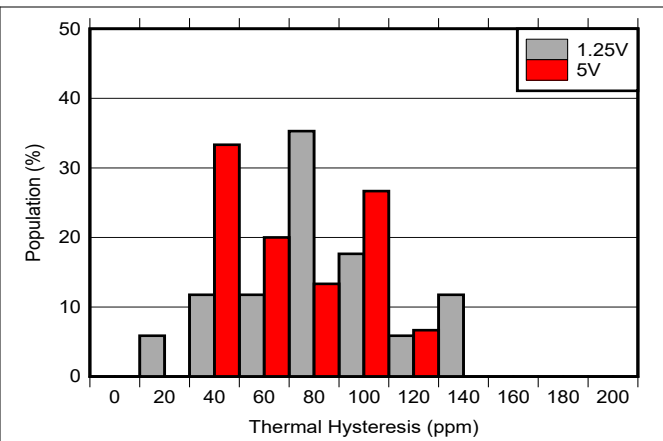

Figure 6-26. Thermal Hysteresis Histogram -40°C to 85°C Cycle 1

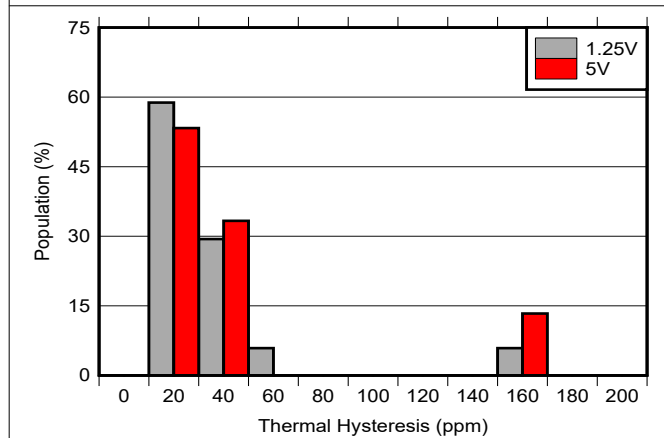

Figure 6-27. Thermal Hysteresis Histogram -40°C to 85°C Cycle 2

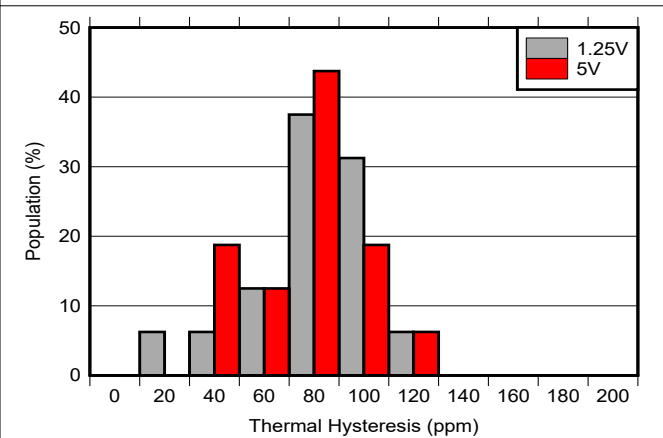

Figure 6-28. Thermal Hysteresis Histogram 0°C to 70°C Cycle 1

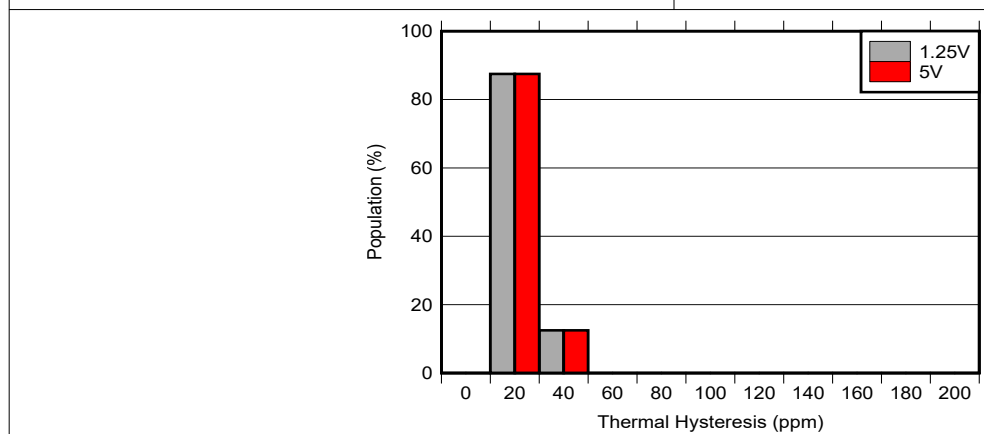

Figure 6-29. Thermal Hysteresis Histogram 0°C to 70°C Cycle 2

6.8 Typical Characteristics REF30

at $T_A = 25^\circ\text{C}$, $V_{IN} = 5\text{V}$, and REF3025 used for typical characteristics (unless otherwise noted)

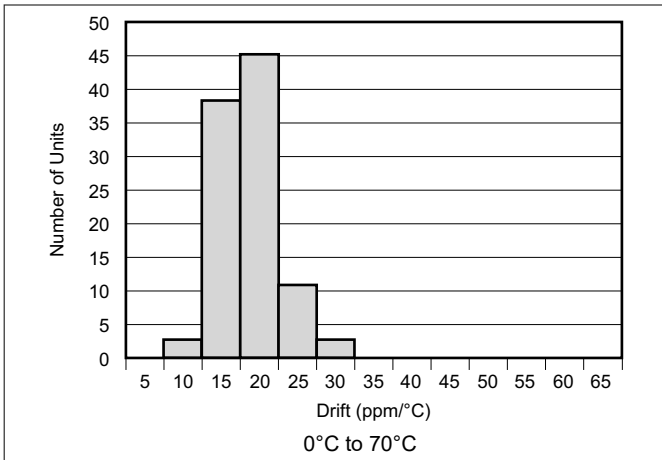

Figure 6-30. Temperature Drift

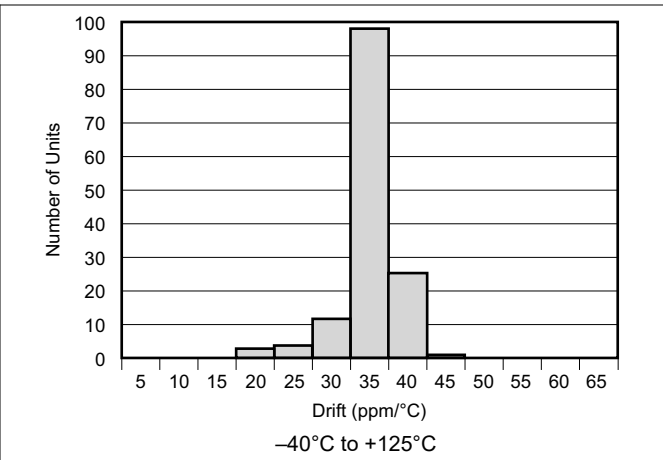

Figure 6-31. Temperature Drift

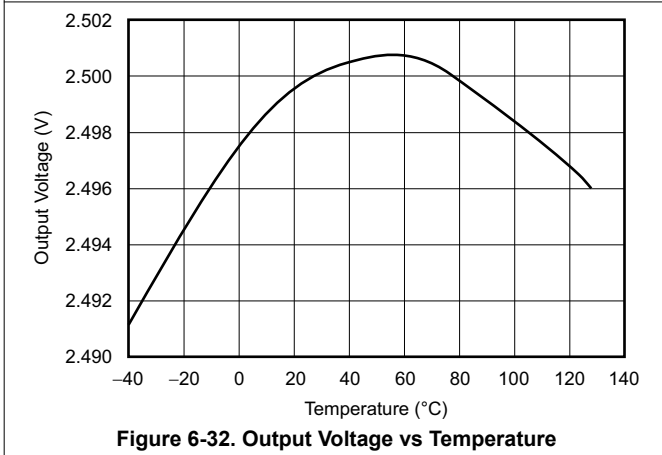

Figure 6-32. Output Voltage vs Temperature

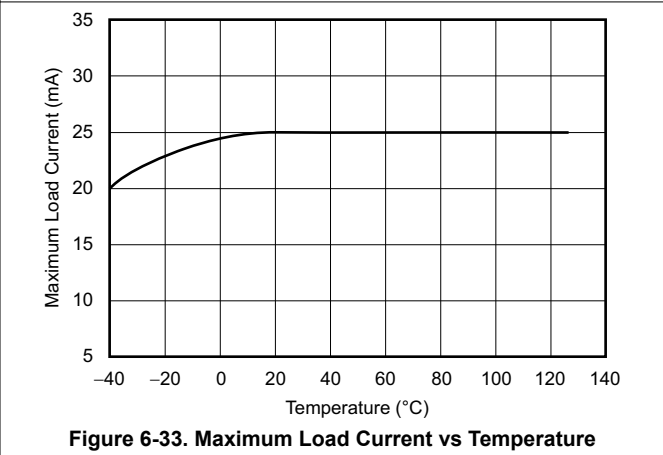

Figure 6-33. Maximum Load Current vs Temperature

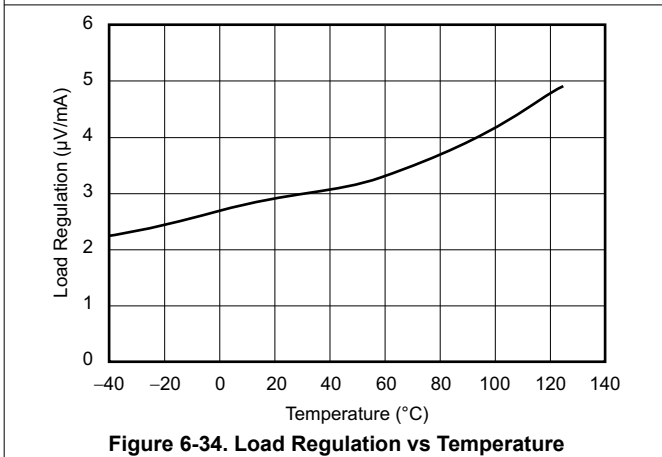

Figure 6-34. Load Regulation vs Temperature

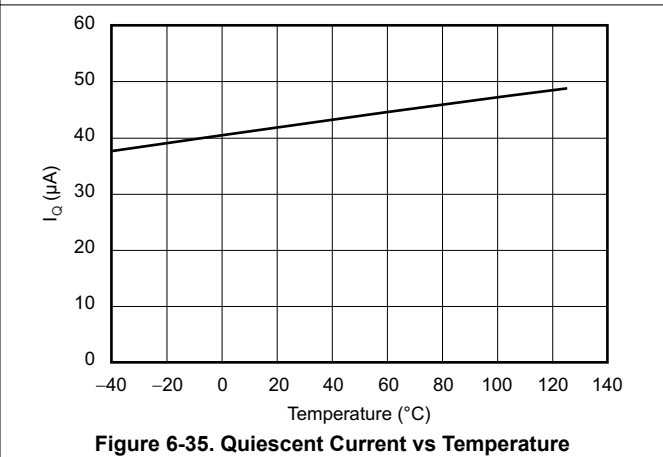

Figure 6-35. Quiescent Current vs Temperature

6.8 Typical Characteristics REF30 (continued)

at $T_A = 25^\circ\text{C}$, $V_{IN} = 5\text{V}$, and REF3025 used for typical characteristics (unless otherwise noted)

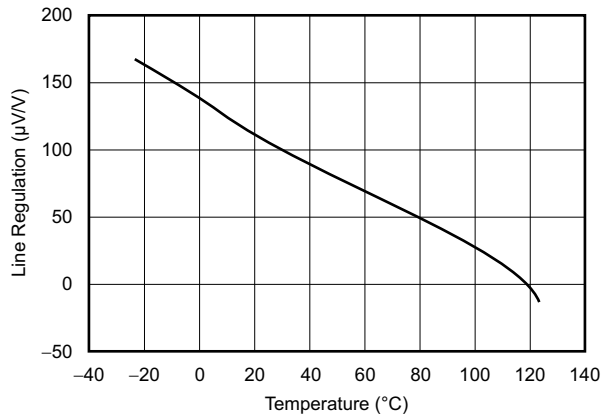

Figure 6-36. Line Regulation vs Temperature

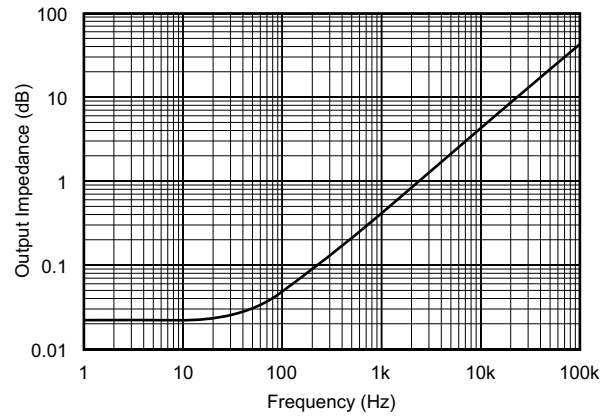

Figure 6-37. Output Impedance vs Frequency

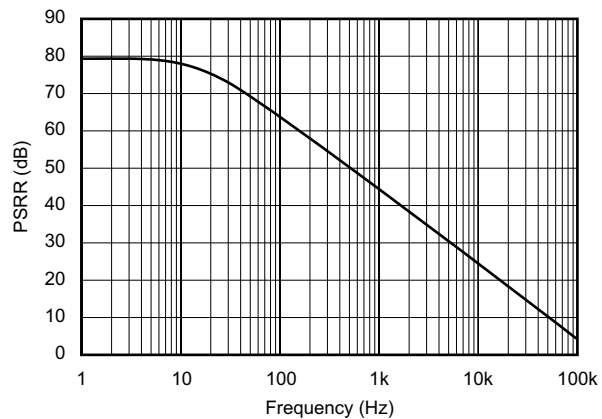

Figure 6-38. Power-Supply Rejection Ratio vs Frequency

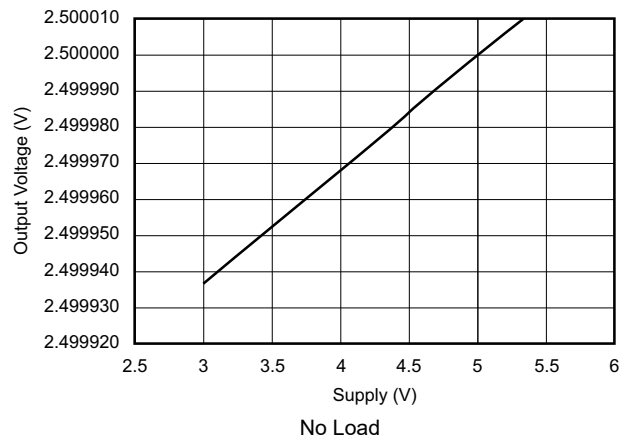

Figure 6-39. Output Voltage vs Supply Voltage

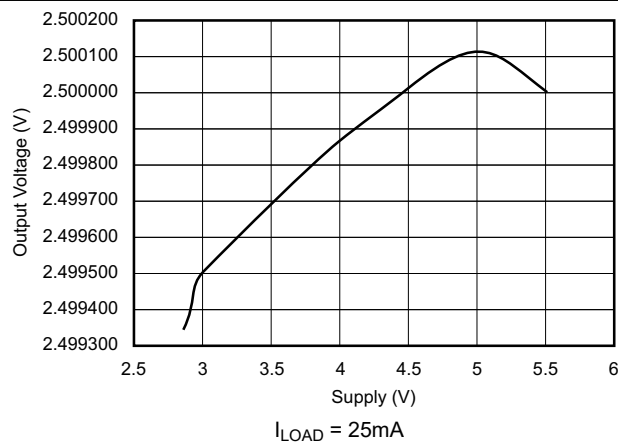

Figure 6-40. Output Voltage vs Supply Voltage

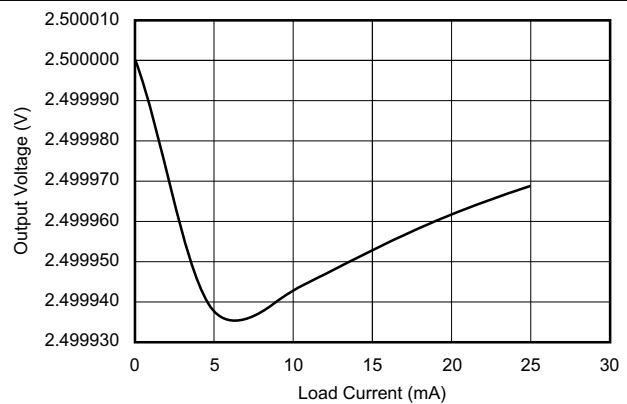
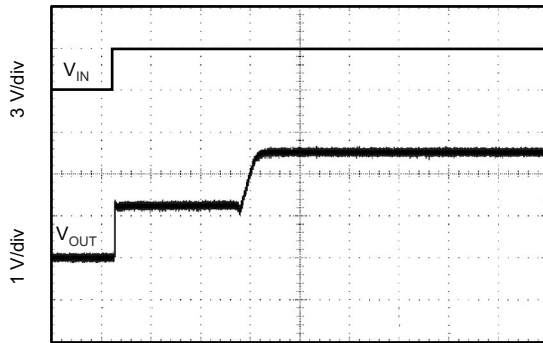

Figure 6-41. Output Voltage vs Load Current

6.8 Typical Characteristics REF30 (continued)

at $T_A = 25^\circ\text{C}$, $V_{IN} = 5\text{V}$, and REF3025 used for typical characteristics (unless otherwise noted)



40 $\mu\text{s}/\text{div}$
 $C_L = 0$, 3V Startup

Figure 6-42. Step Response

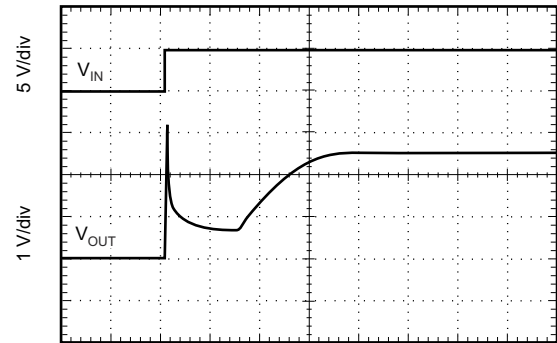

10 $\mu\text{s}/\text{div}$
 $C_L = 0$, 5V startup

Figure 6-43. Step Response

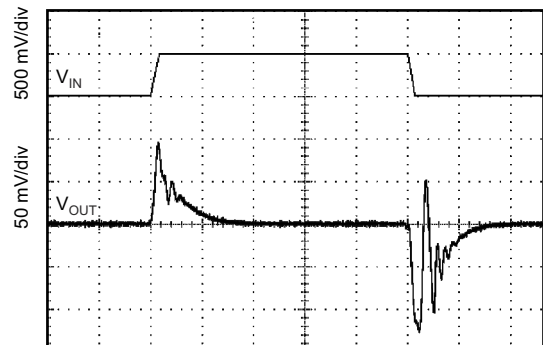

Figure 6-44. Line Transient Response

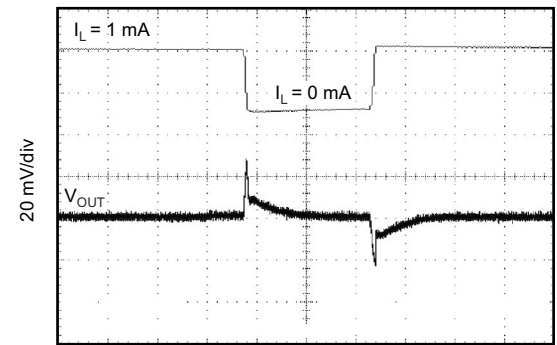

Figure 6-45. 0mA to 1mA Load Transient

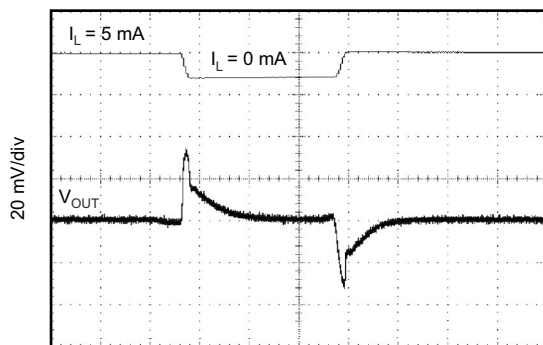

Figure 6-46. 0mA to 5mA Load Transient

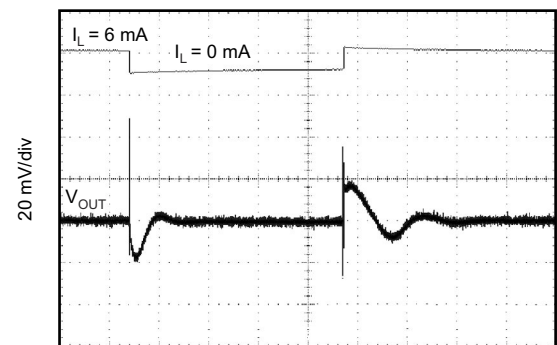

Figure 6-47. 1mA to 6mA Load Transient

6.8 Typical Characteristics REF30 (continued)

at $T_A = 25^\circ\text{C}$, $V_{IN} = 5\text{V}$, and REF3025 used for typical characteristics (unless otherwise noted)

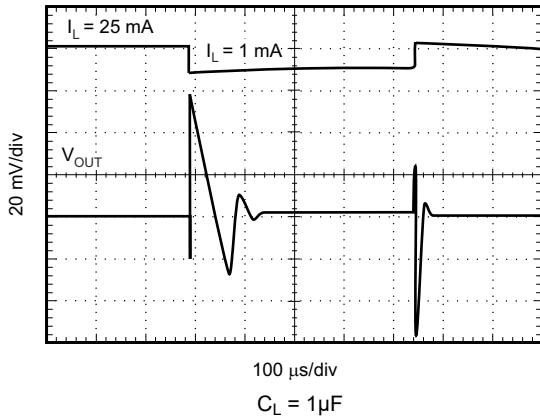

Figure 6-48. 1mA to 25mA Load Transient

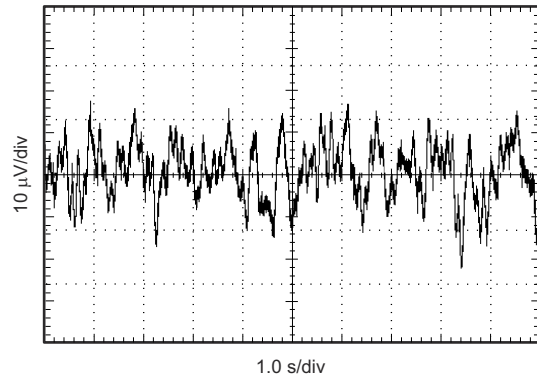

Figure 6-49. 0.1Hz to 10Hz Noise

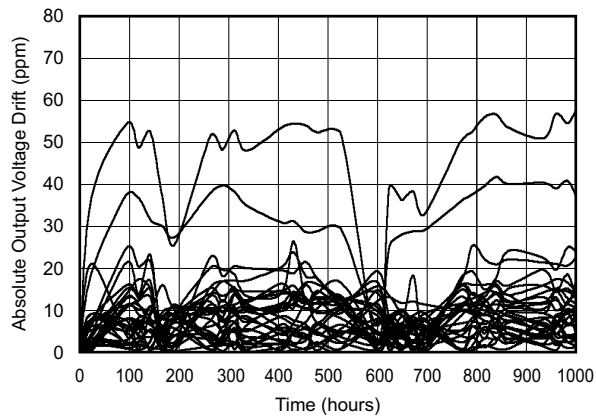

Figure 6-50. Long-Term Stability: 0 to 1000 Hours

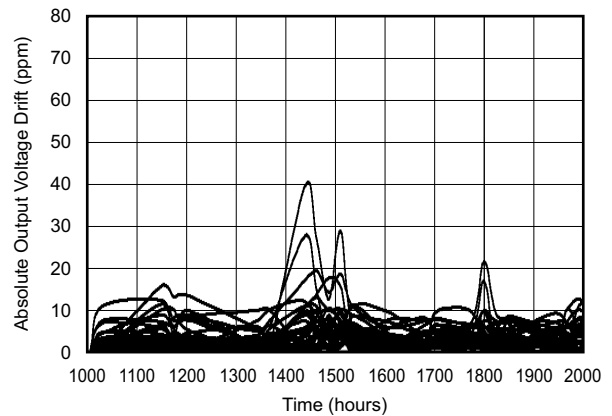

Figure 6-51. Long-Term Stability: 1000 to 2000 Hours

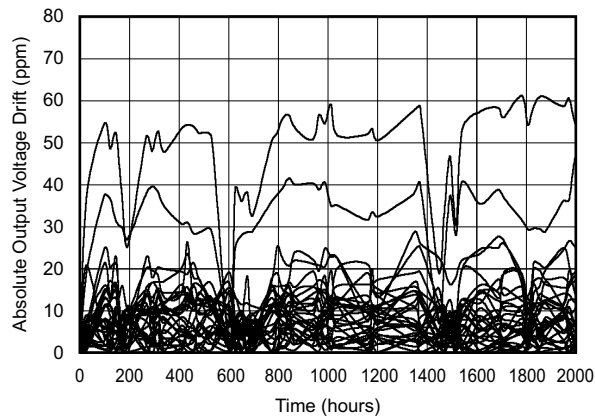

Figure 6-52. Long-Term Stability: 0 to 2000 Hours

7 Detailed Description

7.1 Overview

The REF30 is a series, precision bandgap voltage reference. The basic topology is shown in the [Section 7.2](#). Transistors Q_1 and Q_2 are biased so that the current density of Q_1 is greater than that of Q_2 . The difference of the two base-emitter voltages, $V_{be1} - V_{be2}$, has a positive temperature coefficient and is forced across resistor R_1 . This voltage is gained up and added to the base-emitter voltage of Q_2 , which has a negative coefficient. The resulting output voltage is virtually independent of temperature. The curvature of the bandgap voltage, as shown in [Figure 6-32](#), is due to the slightly nonlinear temperature coefficient of the base-emitter voltage of Q_2 .

7.2 Functional Block Diagram

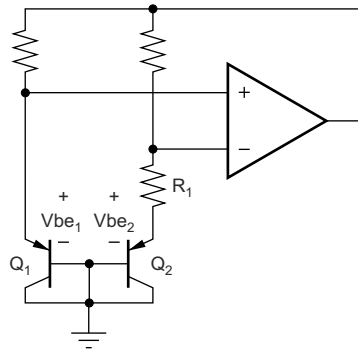

Copyright © 2016, Texas Instruments Incorporated

7.3 Feature Description

7.3.1 Supply Voltage

The REF30 family of references features an extremely low dropout voltage. With the exception of the REF3012, which has a minimum supply requirement of 1.8V, the REF30 can be operated with a supply of only 1mV above the output voltage in an unloaded condition. For loaded conditions, a typical dropout voltage versus load is shown on the front page.

The REF30 features a low quiescent current that is extremely stable over changes in both temperature and supply. The typical room temperature quiescent current is $42\mu\text{A}$, and the maximum quiescent current over temperature is just $59\mu\text{A}$. Additionally, the quiescent current typically changes less than $2.5\mu\text{A}$ over the entire supply range, as shown in [Figure 7-1](#).

Supply voltages below the specified levels can cause the REF30 to momentarily draw currents greater than the typical quiescent current. Use a power supply with a fast rising edge and low output impedance to easily prevent this issue.

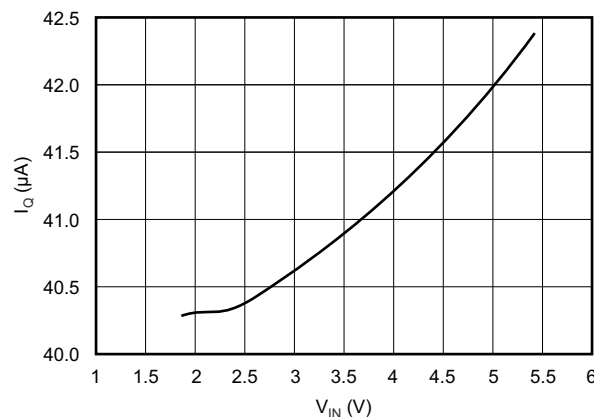

Figure 7-1. Supply Current vs Supply Voltage

7.3.2 Thermal Hysteresis

Thermal hysteresis for the REF30 is defined as the change in output voltage after operating the device at 25°C, cycling the device through the specified temperature range, and returning to 25°C, and can be expressed as shown in Equation 1:

$$V_{\text{HYST}} = \left(\frac{\text{abs}|V_{\text{PRE}} - V_{\text{POST}}|}{V_{\text{NOM}}} \right) \cdot 10^6 \text{ (ppm)} \quad (1)$$

where

- V_{HYST} = Calculated hysteresis
- V_{PRE} = Output voltage measured at 25°C pretemperature cycling
- V_{POST} = Output voltage measured when device has been operated at 25°C, cycled through specified range of –40°C to +125°C, and returned to operation at 25°C.

7.3.3 Temperature Drift

The REF30 exhibits minimal drift error, defined as the change in output voltage over varying temperature. Using the *box* method of drift measurement, the REF30 features a typical drift coefficient of 20ppm from 0°C to 70°C, the primary temperature range of use for many applications. For industrial temperature ranges of –40°C to +125°C, the REF30 family drift increases to a typical value of 50ppm.

7.3.4 Noise Performance

The REF30 generates noise less than 50μV_{PP} between frequencies of 0.1Hz to 10Hz, and can be seen in Figure 6-49. The noise voltage of the REF30 increases with output voltage and operating temperature. Additional filtering can be used to improve output noise levels; however, make sure the output impedance does not degrade AC performance.

7.3.5 Long-Term Stability

Long-term stability refers to the change of the output voltage of a reference over a period of months or years. This effect lessens as time progresses as is apparent by the long-term stability curves. The typical drift value for the REF30 is 24ppm from 0 hours to 1000 hours, and 15ppm from 1000 hours to 2000 hours. This parameter is characterized by measuring 30 units at regular intervals for a period of 2000 hours.

7.3.6 Load Regulation

Load regulation is defined as the change in output voltage as a result of changes in load current. Use a 4 wire measurement (kelvin measurement) methodology for accurate load regulation measurement as shown in Figure 7-2. The force and sense lines tied to the contact area of the output pin reduce the impact of contact and trace resistance, resulting in accurate measurement of the load regulation contributed solely by the REF30xx.

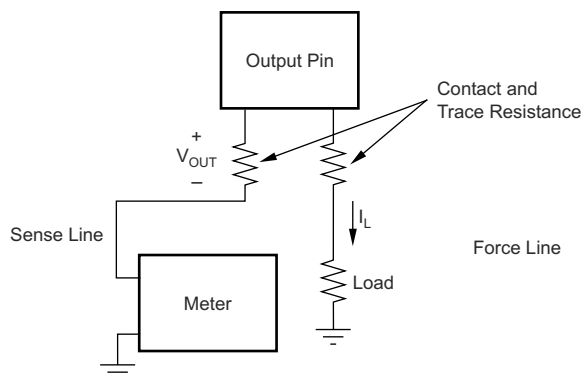

Copyright © 2016, Texas Instruments Incorporated

Figure 7-2. Accurate Load Regulation of REF30

7.4 Device Functional Modes

7.4.1 Negative Reference Voltage

For applications requiring a negative and positive reference voltage, the [OPA703](#) and REF30 can be used to provide a dual-supply reference from a $\pm 5V$ supply. [Figure 7-3](#) shows the REF3025 used to provide a $\pm 2.5V$ supply reference voltage. The low offset voltage and low drift of the OPA703 complement the low drift performance of the REF30 to provide an accurate resolution for split-supply applications.

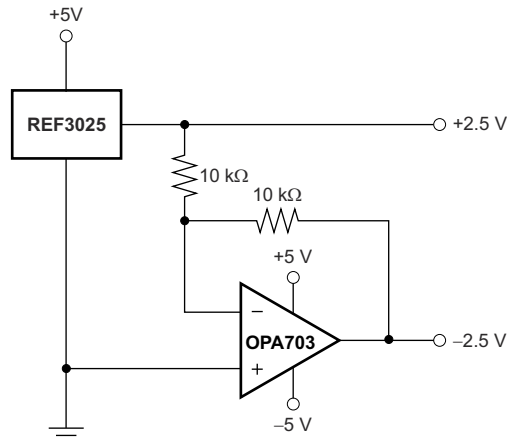

Copyright © 2016, Texas Instruments Incorporated

Figure 7-3. REF3025 Combined With OPA703 to Create Positive and Negative Reference Voltages.

7.4.2 Data Acquisition

Often data acquisition systems require stable voltage references to maintain necessary accuracy. The REF30 family features stability and a wide range of voltages designed for most microcontrollers and data converters. Figure 7-4 and Figure 7-5 show two basic data acquisition systems.

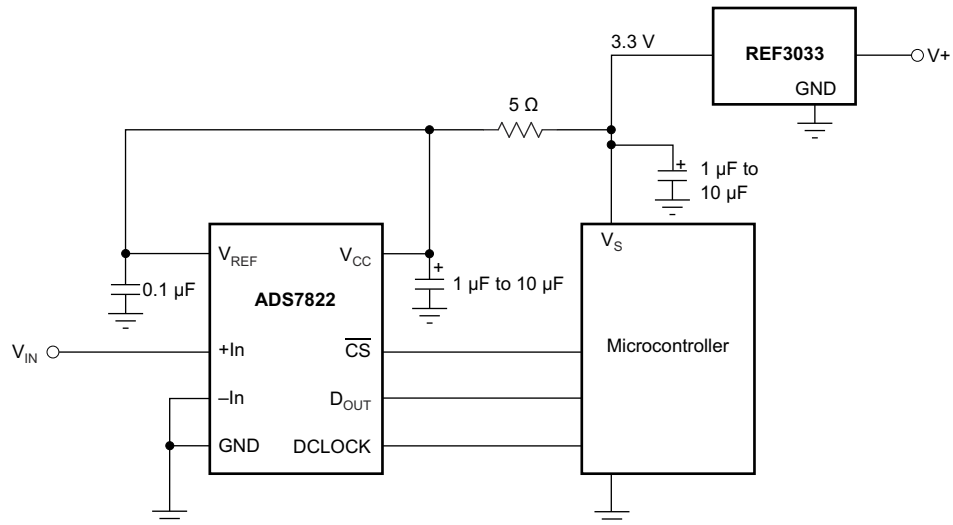

Copyright © 2016, Texas Instruments Incorporated

Figure 7-4. Basic Data Acquisition System 1

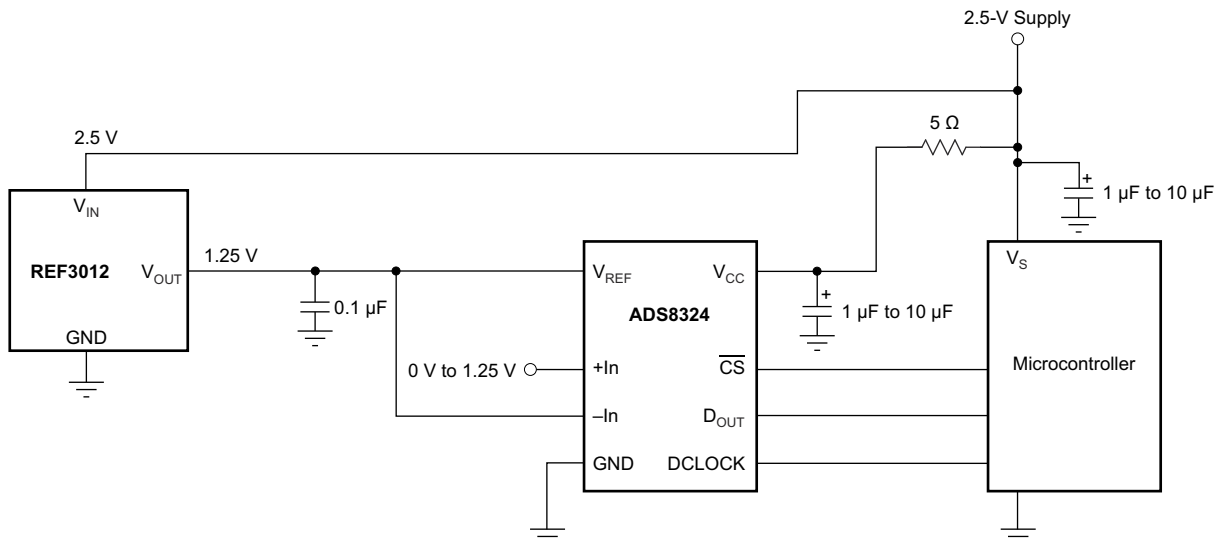

Copyright © 2016, Texas Instruments Incorporated

Figure 7-5. Basic Data Acquisition System 2

8 Application and Implementation

Note

Information in the following applications sections is not part of the TI component specification, and TI does not warrant its accuracy or completeness. TI's customers are responsible for determining suitability of components for their purposes, as well as validating and testing their design implementation to confirm system functionality.

8.1 Application Information

For normal operation, the REF30 does not require a capacitor on the output. If a capacitive load is connected, take special care when using low equivalent series resistance (ESR) capacitors and high capacitance. This precaution is especially true for low-output voltage devices; therefore, for the REF3012 use a low-ESR capacitance of 10 μ F or less. [Figure 8-1](#) shows the typical connections required for operation of the REF30. A supply bypass capacitor of 0.1 μ F is always recommended.

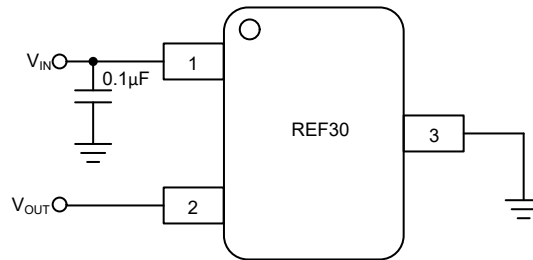

Figure 8-1. Typical Connections for Operating REF30

8.2 Typical Application

[Figure 8-2](#) shows a low-power reference and conditioning circuit. This circuit attenuates and level-shifts a bipolar input voltage within the proper input range of a single-supply low power 16-Bit $\Delta\Sigma$ ADC, such as the one inside the [MSP430](#) or other similar single-supply ADCs. Precision reference circuits are used to level-shift the input signal, provide the ADC reference voltage and to create a well-regulated supply voltage for the low-power analog circuitry. A low-power, zero-drift, op-amp circuit is used to attenuate and level-shift the input signal.

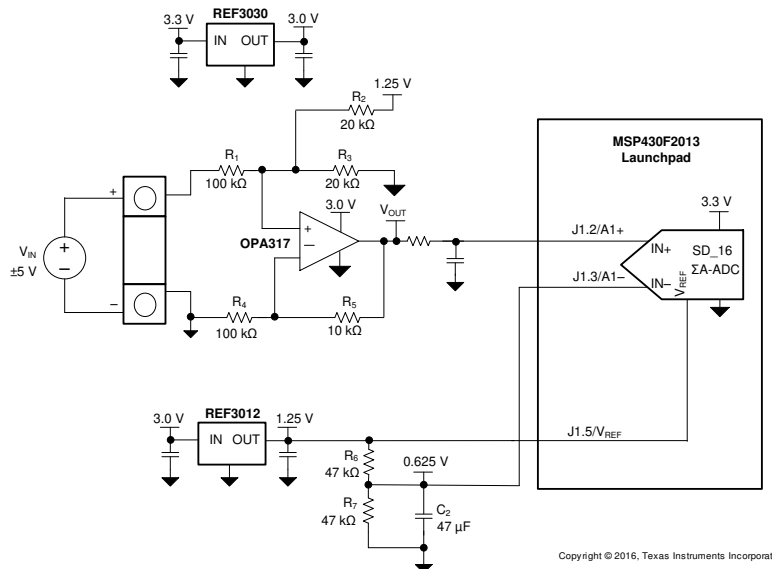

Figure 8-2. Low-Power Reference and Bipolar Voltage Conditioning Circuit for Low-Power ADCs

8.2.1 Design Requirements

- Supply Voltage: 3.3V
- Maximum Input Voltage: $\pm 6V$
- Specified Input Voltage: $\pm 5V$
- ADC Reference Voltage: 1.25V

The goal for this design is to accurately condition a $\pm 5V$ bipolar input voltage into a voltage that works for conversion by a low-voltage ADC with a 1.25V reference voltage, V_{REF} , and an input voltage range of $V_{REF}/2$. The circuit can function with reduced performance over a wider input range of at least $\pm 6V$ to allow for easier protection of overvoltage conditions.

8.2.2 Detailed Design Procedure

Figure 8-2 depicts a simplified schematic for this design showing the MSP430 ADC inputs and full input conditioning circuitry. The ADC is configured for a bipolar measurement where final conversion result is the differential voltage between the voltage at the positive and negative ADC inputs. The bipolar, GND-referenced input signal must be level-shifted and attenuated by the op amp so that the output is biased to $V_{REF}/2$ and has a differential voltage that is within the $\pm V_{REF}/2$ input range of the ADC.

8.2.3 Application Curves

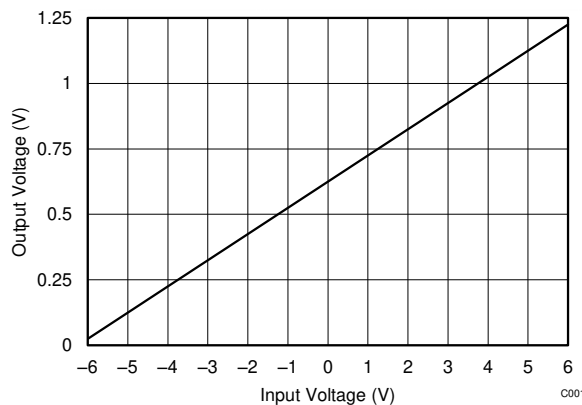

Figure 8-3. OPA317 Output Voltage vs Input Voltage

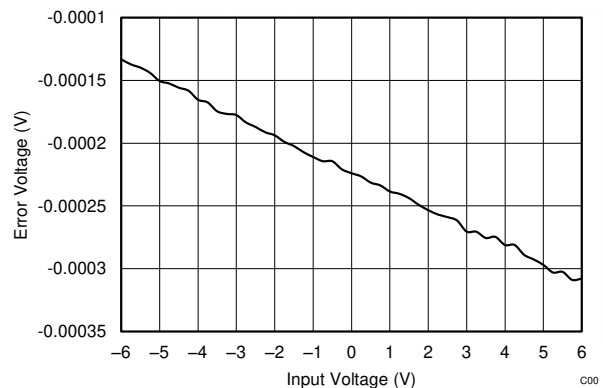

Figure 8-4. OPA317 Output Voltage Error vs Input Voltage

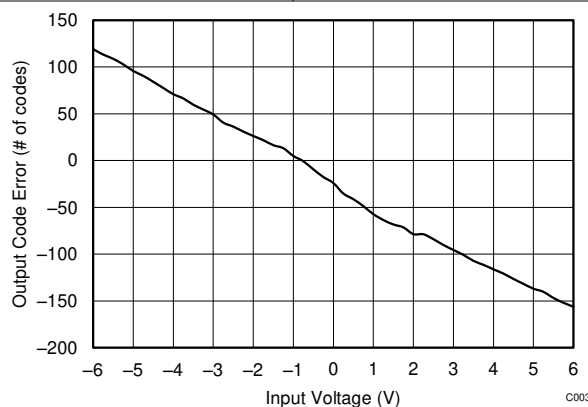

Figure 8-5. Output Code Error vs Input Voltage

8.3 Power Supply Recommendations

The REF30 family of references feature an extremely low-dropout voltage. These references can be operated with a supply of only 50mV above the output voltage. For loaded reference conditions, a typical dropout voltage versus load is shown in the front page plot, [Output Voltage vs Temperature \(REF3025E\)](#). Use a supply bypass capacitor greater than 0.47 μ F.

8.4 Layout

8.4.1 Layout Guidelines

Figure 8-6 illustrates an example of a printed-circuit board (PCB) layout using the REF30. Some key considerations are:

- Connect low-ESR, 0.1 μ F ceramic bypass capacitors at V_{IN} of the REF30.
- Decouple other active devices in the system per the device specifications.
- Use a solid ground plane to help distribute heat and reduces electromagnetic interference (EMI) noise pickup.
- Place the external components as close to the device as possible. This configuration prevents parasitic errors (such as the Seebeck effect) from occurring.
- Minimize trace length between the reference and bias connections to the INA and ADC to reduce noise pickup.
- Do not run sensitive analog traces in parallel with digital traces. Avoid crossing digital and analog traces if possible, and only make perpendicular crossings when absolutely necessary.

8.4.2 Layout Example

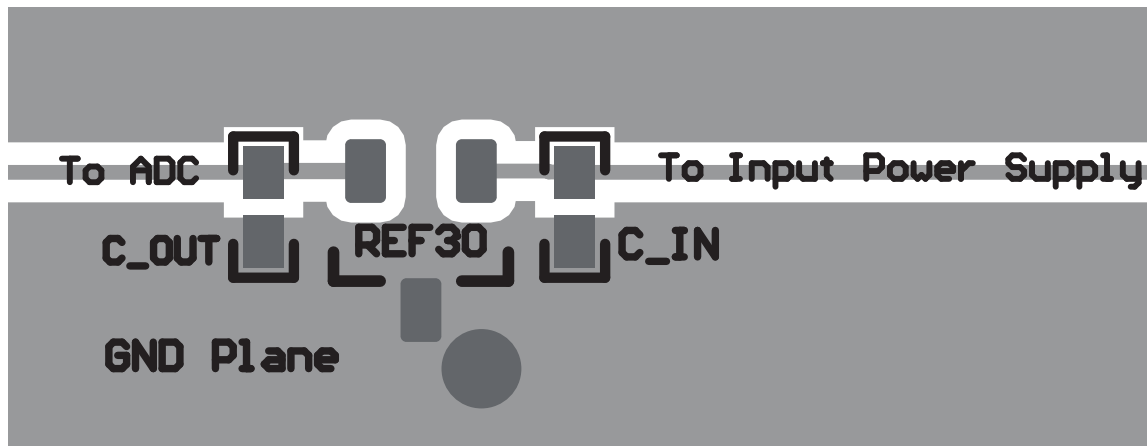

Figure 8-6. Layout Example

9 Device and Documentation Support

9.1 Documentation Support

9.1.1 Related Documentation

[CMOS, Rail-to-Rail, I/O Operational Amplifiers](#) (SBOS180)

[REF29xx 100ppm/°C, 50µA in 3-Pin SOT-23 CMOS Voltage Reference](#) (SBVS033)

9.2 Related Links

Table 9-1 lists quick access links. Categories include technical documents, support and community resources, tools and software, and quick access to sample or buy.

Table 9-1. Related Links

PARTS	PRODUCT FOLDER	SAMPLE & BUY	TECHNICAL DOCUMENTS	TOOLS & SOFTWARE	SUPPORT & COMMUNITY
REF3012	Click here	Click here	Click here	Click here	Click here
REF3020	Click here	Click here	Click here	Click here	Click here
REF3025	Click here	Click here	Click here	Click here	Click here
REF3030	Click here	Click here	Click here	Click here	Click here
REF3033	Click here	Click here	Click here	Click here	Click here
REF3040	Click here	Click here	Click here	Click here	Click here

9.3 Receiving Notification of Documentation Updates

To receive notification of documentation updates, navigate to the device product folder on [ti.com](#). Click on *Notifications* to register and receive a weekly digest of any product information that has changed. For change details, review the revision history included in any revised document.

9.4 Support Resources

[TI E2E™ support forums](#) are an engineer's go-to source for fast, verified answers and design help — straight from the experts. Search existing answers or ask your own question to get the quick design help you need.

Linked content is provided "AS IS" by the respective contributors. They do not constitute TI specifications and do not necessarily reflect TI's views; see TI's [Terms of Use](#).

9.5 Trademarks

TI E2E™ is a trademark of Texas Instruments.

All trademarks are the property of their respective owners.

9.6 Electrostatic Discharge Caution



This integrated circuit can be damaged by ESD. Texas Instruments recommends that all integrated circuits be handled with appropriate precautions. Failure to observe proper handling and installation procedures can cause damage.

ESD damage can range from subtle performance degradation to complete device failure. Precision integrated circuits may be more susceptible to damage because very small parametric changes could cause the device not to meet its published specifications.

9.7 Glossary

[TI Glossary](#) This glossary lists and explains terms, acronyms, and definitions.

10 Revision History

NOTE: Page numbers for previous revisions may differ from page numbers in the current version.

Changes from Revision J (July 2025) to Revision K (December 2025)	Page
• Updated REF30E device features to match the device performance specifications at release to market and updated REF30E performance specifications throughout the document.....	1
• Deleted 'preview device' note for REF30E series.....	1
• Deleted "Product Preview" tag for REF30E device orderable part numbers.	2
• Updated REF30E performance specifications.....	2
• Updated REF30E specifications to meet performance at release to market.....	4
• Updated REF30E Typical Characteristics plots with release data.....	10

Changes from Revision I (July 2022) to Revision J (July 2025)	Page
• Added preview information for upcoming device REF30E throughout the document.....	1
• Updated the GPN name from RE30xx to REF30 throughout the document.....	1
• Added REF30E device details.....	2
• Added typical characteristics plots for preview device REF30E.....	10
• Updated the bypass capacitor recommendation and typical connection diagram.....	23
• Updated the layout image for REF30 GPN.....	25

Changes from Revision H (February 2018) to Revision I (July 2022)	Page
• Updated the numbering format for tables, figures, and cross-references throughout the document.....	1

Changes from Revision G (November 2015) to Revision H (February 2018)	Page
• Added NOTE to the Section 8 section	23

Changes from Revision F (August 2008) to Revision G (November 2015)	Page
• Added <i>Device Information, ESD Ratings, Recommended Operating Conditions, and Thermal Information</i> tables.....	1
• Added <i>Detailed Description, Applications and Implementation, Power-Supply Recommendations, Layout, Device and Documentation Support, and Mechanical, Packaging, and Orderable Information</i> sections.....	1
• Changed text in <i>Description</i> section	1

11 Mechanical, Packaging, and Orderable Information

The following pages include mechanical packaging and orderable information. This information is the most current data available for the designated devices. This data is subject to change without notice and revision of this document. For browser-based versions of this data sheet, refer to the left-hand navigation.

PACKAGING INFORMATION

Orderable part number	Status (1)	Material type (2)	Package Pins	Package qty Carrier	RoHS (3)	Lead finish/ Ball material (4)	MSL rating/ Peak reflow (5)	Op temp (°C)	Part marking (6)
PREF3030EAIDBZR	Active	Preproduction	SOT-23 (DBZ) 3	3000 LARGE T&R	-	Call TI	Call TI	-40 to 125	
REF3012AIDBZR	Active	Production	SOT-23 (DBZ) 3	3000 LARGE T&R	Yes	NIPDAUAG	Level-1-260C-UNLIM	-40 to 125	R30A
REF3012AIDBZR.B	Active	Production	SOT-23 (DBZ) 3	3000 LARGE T&R	Yes	NIPDAUAG	Level-1-260C-UNLIM	-40 to 125	R30A
REF3012AIDBZT	Active	Production	SOT-23 (DBZ) 3	250 SMALL T&R	Yes	NIPDAUAG	Level-1-260C-UNLIM	-40 to 125	R30A
REF3012AIDBZT.B	Active	Production	SOT-23 (DBZ) 3	250 SMALL T&R	Yes	NIPDAUAG	Level-1-260C-UNLIM	-40 to 125	R30A
REF3012EAIDBZR	Active	Production	SOT-23 (DBZ) 3	3000 LARGE T&R	Yes	SN	Level-1-260C-UNLIM	-40 to 125	30EAC
REF3016EAIDBZR	Active	Production	SOT-23 (DBZ) 3	3000 LARGE T&R	Yes	SN	Level-1-260C-UNLIM	-40 to 125	30EBC
REF3018EAIDBZR	Active	Production	SOT-23 (DBZ) 3	3000 LARGE T&R	Yes	SN	Level-1-260C-UNLIM	-40 to 125	30ECC
REF3020AIDBZR	Active	Production	SOT-23 (DBZ) 3	3000 LARGE T&R	Yes	NIPDAUAG	Level-1-260C-UNLIM	-40 to 125	R30B
REF3020AIDBZR.B	Active	Production	SOT-23 (DBZ) 3	3000 LARGE T&R	Yes	NIPDAUAG	Level-1-260C-UNLIM	-40 to 125	R30B
REF3020AIDBZT	Active	Production	SOT-23 (DBZ) 3	250 SMALL T&R	Yes	NIPDAUAG	Level-1-260C-UNLIM	-40 to 125	R30B
REF3020AIDBZT.B	Active	Production	SOT-23 (DBZ) 3	250 SMALL T&R	Yes	NIPDAUAG	Level-1-260C-UNLIM	-40 to 125	R30B
REF3020EAIDBZR	Active	Production	SOT-23 (DBZ) 3	3000 LARGE T&R	Yes	SN	Level-1-260C-UNLIM	-40 to 125	30EDC
REF3025AIDBZR	Active	Production	SOT-23 (DBZ) 3	3000 LARGE T&R	Yes	NIPDAUAG	Level-1-260C-UNLIM	-40 to 125	R30C
REF3025AIDBZR.B	Active	Production	SOT-23 (DBZ) 3	3000 LARGE T&R	Yes	NIPDAUAG	Level-1-260C-UNLIM	-40 to 125	R30C
REF3025AIDBZT	Active	Production	SOT-23 (DBZ) 3	250 SMALL T&R	Yes	NIPDAUAG	Level-1-260C-UNLIM	-40 to 125	R30C
REF3025AIDBZT.B	Active	Production	SOT-23 (DBZ) 3	250 SMALL T&R	Yes	NIPDAUAG	Level-1-260C-UNLIM	-40 to 125	R30C
REF3025EAIDBZR	Active	Production	SOT-23 (DBZ) 3	3000 LARGE T&R	Yes	SN	Level-1-260C-UNLIM	-40 to 125	30EEC
REF3030AIDBZR	Active	Production	SOT-23 (DBZ) 3	3000 LARGE T&R	Yes	NIPDAUAG	Level-1-260C-UNLIM	-40 to 125	R30F
REF3030AIDBZR.B	Active	Production	SOT-23 (DBZ) 3	3000 LARGE T&R	Yes	NIPDAUAG	Level-1-260C-UNLIM	-40 to 125	R30F
REF3030AIDBZT	Active	Production	SOT-23 (DBZ) 3	250 SMALL T&R	Yes	NIPDAUAG	Level-1-260C-UNLIM	-40 to 125	R30F
REF3030AIDBZT.B	Active	Production	SOT-23 (DBZ) 3	250 SMALL T&R	Yes	NIPDAUAG	Level-1-260C-UNLIM	-40 to 125	R30F
REF3030EAIDBZR	Active	Production	SOT-23 (DBZ) 3	3000 LARGE T&R	Yes	SN	Level-1-260C-UNLIM	-40 to 125	30EFC
REF3033AIDBZR	Active	Production	SOT-23 (DBZ) 3	3000 LARGE T&R	Yes	NIPDAUAG	Level-1-260C-UNLIM	-40 to 125	R30D
REF3033AIDBZR.B	Active	Production	SOT-23 (DBZ) 3	3000 LARGE T&R	Yes	NIPDAUAG	Level-1-260C-UNLIM	-40 to 125	R30D
REF3033AIDBZT	Active	Production	SOT-23 (DBZ) 3	250 SMALL T&R	Yes	NIPDAUAG	Level-1-260C-UNLIM	-40 to 125	R30D
REF3033AIDBZT.B	Active	Production	SOT-23 (DBZ) 3	250 SMALL T&R	Yes	NIPDAUAG	Level-1-260C-UNLIM	-40 to 125	R30D
REF3033EAIDBZR	Active	Production	SOT-23 (DBZ) 3	3000 LARGE T&R	Yes	SN	Level-1-260C-UNLIM	-40 to 125	30EGC
REF3040AIDBZR	Active	Production	SOT-23 (DBZ) 3	3000 LARGE T&R	Yes	NIPDAUAG	Level-1-260C-UNLIM	-40 to 125	R30E

Orderable part number	Status (1)	Material type (2)	Package Pins	Package qty Carrier	RoHS (3)	Lead finish/ Ball material (4)	MSL rating/ Peak reflow (5)	Op temp (°C)	Part marking (6)
REF3040AIDBZR.B	Active	Production	SOT-23 (DBZ) 3	3000 LARGE T&R	Yes	NIPDAUAG	Level-1-260C-UNLIM	-40 to 125	R30E
REF3040AIDBZT	Active	Production	SOT-23 (DBZ) 3	250 SMALL T&R	Yes	NIPDAUAG	Level-1-260C-UNLIM	-40 to 125	R30E
REF3040AIDBZT.B	Active	Production	SOT-23 (DBZ) 3	250 SMALL T&R	Yes	NIPDAUAG	Level-1-260C-UNLIM	-40 to 125	R30E
REF3040EAIDBZR	Active	Production	SOT-23 (DBZ) 3	3000 LARGE T&R	Yes	SN	Level-1-260C-UNLIM	-40 to 125	30EHC
REF3050EAIDBZR	Active	Production	SOT-23 (DBZ) 3	3000 LARGE T&R	Yes	SN	Level-1-260C-UNLIM	-40 to 125	30EJC

(1) **Status:** For more details on status, see our [product life cycle](#).

(2) **Material type:** When designated, preproduction parts are prototypes/experimental devices, and are not yet approved or released for full production. Testing and final process, including without limitation quality assurance, reliability performance testing, and/or process qualification, may not yet be complete, and this item is subject to further changes or possible discontinuation. If available for ordering, purchases will be subject to an additional waiver at checkout, and are intended for early internal evaluation purposes only. These items are sold without warranties of any kind.

(3) **RoHS values:** Yes, No, RoHS Exempt. See the [TI RoHS Statement](#) for additional information and value definition.

(4) **Lead finish/Ball material:** Parts may have multiple material finish options. Finish options are separated by a vertical ruled line. Lead finish/Ball material values may wrap to two lines if the finish value exceeds the maximum column width.

(5) **MSL rating/Peak reflow:** The moisture sensitivity level ratings and peak solder (reflow) temperatures. In the event that a part has multiple moisture sensitivity ratings, only the lowest level per JEDEC standards is shown. Refer to the shipping label for the actual reflow temperature that will be used to mount the part to the printed circuit board.

(6) **Part marking:** There may be an additional marking, which relates to the logo, the lot trace code information, or the environmental category of the part.

Multiple part markings will be inside parentheses. Only one part marking contained in parentheses and separated by a "~" will appear on a part. If a line is indented then it is a continuation of the previous line and the two combined represent the entire part marking for that device.

Important Information and Disclaimer: The information provided on this page represents TI's knowledge and belief as of the date that it is provided. TI bases its knowledge and belief on information provided by third parties, and makes no representation or warranty as to the accuracy of such information. Efforts are underway to better integrate information from third parties. TI has taken and continues to take reasonable steps to provide representative and accurate information but may not have conducted destructive testing or chemical analysis on incoming materials and chemicals. TI and TI suppliers consider certain information to be proprietary, and thus CAS numbers and other limited information may not be available for release.

In no event shall TI's liability arising out of such information exceed the total purchase price of the TI part(s) at issue in this document sold by TI to Customer on an annual basis.

TAPE AND REEL INFORMATION



QUADRANT ASSIGNMENTS FOR PIN 1 ORIENTATION IN TAPE



*All dimensions are nominal

Device	Package Type	Package Drawing	Pins	SPQ	Reel Diameter (mm)	Reel Width W1 (mm)	A0 (mm)	B0 (mm)	K0 (mm)	P1 (mm)	W (mm)	Pin1 Quadrant
REF3012AIDBZR	SOT-23	DBZ	3	3000	179.0	8.4	3.15	2.95	1.22	4.0	8.0	Q3
REF3012AIDBZT	SOT-23	DBZ	3	250	179.0	8.4	3.15	2.95	1.22	4.0	8.0	Q3
REF3012EAIDBZR	SOT-23	DBZ	3	3000	180.0	8.4	3.2	2.85	1.3	4.0	8.0	Q3
REF3016EAIDBZR	SOT-23	DBZ	3	3000	180.0	8.4	3.2	2.85	1.3	4.0	8.0	Q3
REF3018EAIDBZR	SOT-23	DBZ	3	3000	180.0	8.4	3.2	2.85	1.3	4.0	8.0	Q3
REF3020AIDBZR	SOT-23	DBZ	3	3000	179.0	8.4	3.15	2.95	1.22	4.0	8.0	Q3
REF3020AIDBZT	SOT-23	DBZ	3	250	179.0	8.4	3.15	2.95	1.22	4.0	8.0	Q3
REF3020EAIDBZR	SOT-23	DBZ	3	3000	180.0	8.4	3.2	2.85	1.3	4.0	8.0	Q3
REF3025AIDBZR	SOT-23	DBZ	3	3000	180.0	8.4	3.15	2.95	1.22	4.0	8.0	Q3
REF3025AIDBZT	SOT-23	DBZ	3	250	179.0	8.4	3.15	2.95	1.22	4.0	8.0	Q3
REF3025EAIDBZR	SOT-23	DBZ	3	3000	180.0	8.4	3.2	2.85	1.3	4.0	8.0	Q3
REF3030AIDBZR	SOT-23	DBZ	3	3000	179.0	8.4	3.15	2.95	1.22	4.0	8.0	Q3
REF3030AIDBZT	SOT-23	DBZ	3	250	179.0	8.4	3.15	2.95	1.22	4.0	8.0	Q3
REF3030EAIDBZR	SOT-23	DBZ	3	3000	180.0	8.4	3.2	2.85	1.3	4.0	8.0	Q3
REF3033AIDBZR	SOT-23	DBZ	3	3000	179.0	8.4	3.15	2.95	1.22	4.0	8.0	Q3
REF3033AIDBZT	SOT-23	DBZ	3	250	179.0	8.4	3.15	2.95	1.22	4.0	8.0	Q3

Device	Package Type	Package Drawing	Pins	SPQ	Reel Diameter (mm)	Reel Width W1 (mm)	A0 (mm)	B0 (mm)	K0 (mm)	P1 (mm)	W (mm)	Pin1 Quadrant
REF3033EAIDBZR	SOT-23	DBZ	3	3000	180.0	8.4	3.2	2.85	1.3	4.0	8.0	Q3
REF3040AIDBZR	SOT-23	DBZ	3	3000	179.0	8.4	3.15	2.95	1.22	4.0	8.0	Q3
REF3040AIDBZT	SOT-23	DBZ	3	250	179.0	8.4	3.15	2.95	1.22	4.0	8.0	Q3
REF3040EAIDBZR	SOT-23	DBZ	3	3000	180.0	8.4	3.2	2.85	1.3	4.0	8.0	Q3
REF3050EAIDBZR	SOT-23	DBZ	3	3000	180.0	8.4	3.2	2.85	1.3	4.0	8.0	Q3

TAPE AND REEL BOX DIMENSIONS

*All dimensions are nominal

Device	Package Type	Package Drawing	Pins	SPQ	Length (mm)	Width (mm)	Height (mm)
REF3012AIDBZR	SOT-23	DBZ	3	3000	200.0	183.0	25.0
REF3012AIDBZT	SOT-23	DBZ	3	250	200.0	183.0	25.0
REF3012EAIDBZR	SOT-23	DBZ	3	3000	210.0	185.0	35.0
REF3016EAIDBZR	SOT-23	DBZ	3	3000	210.0	185.0	35.0
REF3018EAIDBZR	SOT-23	DBZ	3	3000	210.0	185.0	35.0
REF3020AIDBZR	SOT-23	DBZ	3	3000	200.0	183.0	25.0
REF3020AIDBZT	SOT-23	DBZ	3	250	200.0	183.0	25.0
REF3020EAIDBZR	SOT-23	DBZ	3	3000	210.0	185.0	35.0
REF3025AIDBZR	SOT-23	DBZ	3	3000	200.0	183.0	25.0
REF3025AIDBZT	SOT-23	DBZ	3	250	200.0	183.0	25.0
REF3025EAIDBZR	SOT-23	DBZ	3	3000	210.0	185.0	35.0
REF3030AIDBZR	SOT-23	DBZ	3	3000	200.0	183.0	25.0
REF3030AIDBZT	SOT-23	DBZ	3	250	200.0	183.0	25.0
REF3030EAIDBZR	SOT-23	DBZ	3	3000	210.0	185.0	35.0
REF3033AIDBZR	SOT-23	DBZ	3	3000	200.0	183.0	25.0
REF3033AIDBZT	SOT-23	DBZ	3	250	200.0	183.0	25.0
REF3033EAIDBZR	SOT-23	DBZ	3	3000	210.0	185.0	35.0
REF3040AIDBZR	SOT-23	DBZ	3	3000	200.0	183.0	25.0

Device	Package Type	Package Drawing	Pins	SPQ	Length (mm)	Width (mm)	Height (mm)
REF3040AIDBZT	SOT-23	DBZ	3	250	200.0	183.0	25.0
REF3040EAIDBZR	SOT-23	DBZ	3	3000	210.0	185.0	35.0
REF3050EAIDBZR	SOT-23	DBZ	3	3000	210.0	185.0	35.0

DBZ0003A



PACKAGE OUTLINE

SOT-23 - 1.12 mm max height

SMALL OUTLINE TRANSISTOR

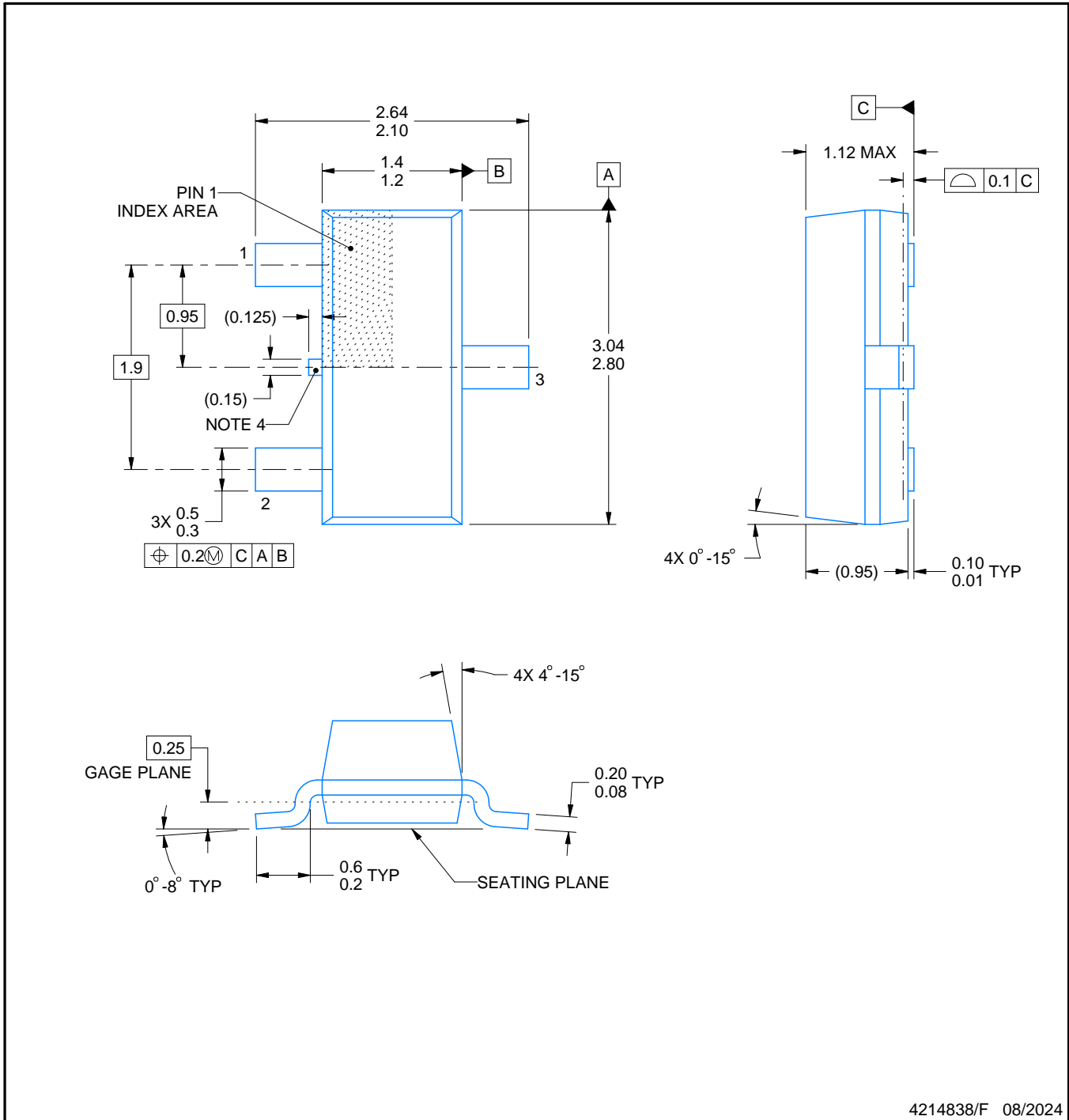

4214838/F 08/2024

NOTES:

1. All linear dimensions are in millimeters. Any dimensions in parenthesis are for reference only. Dimensioning and tolerancing per ASME Y14.5M.
2. This drawing is subject to change without notice.
3. Reference JEDEC registration TO-236, except minimum foot length.
4. Support pin may differ or may not be present.
5. Body dimensions do not include mold flash, protrusions, or gate burrs. Mold flash, protrusions, or gate burrs shall not exceed 0.25mm per side

EXAMPLE BOARD LAYOUT

DBZ0003A

SOT-23 - 1.12 mm max height

SMALL OUTLINE TRANSISTOR



LAND PATTERN EXAMPLE
SCALE:15X



SOLDER MASK DETAILS

4214838/F 08/2024

NOTES: (continued)

5. Publication IPC-7351 may have alternate designs.
6. Solder mask tolerances between and around signal pads can vary based on board fabrication site.

EXAMPLE STENCIL DESIGN

DBZ0003A

SOT-23 - 1.12 mm max height

SMALL OUTLINE TRANSISTOR



SOLDER PASTE EXAMPLE
BASED ON 0.125 THICK STENCIL
SCALE:15X

4214838/F 08/2024

NOTES: (continued)

7. Laser cutting apertures with trapezoidal walls and rounded corners may offer better paste release. IPC-7525 may have alternate design recommendations.
8. Board assembly site may have different recommendations for stencil design.

IMPORTANT NOTICE AND DISCLAIMER

TI PROVIDES TECHNICAL AND RELIABILITY DATA (INCLUDING DATASHEETS), DESIGN RESOURCES (INCLUDING REFERENCE DESIGNS), APPLICATION OR OTHER DESIGN ADVICE, WEB TOOLS, SAFETY INFORMATION, AND OTHER RESOURCES "AS IS" AND WITH ALL FAULTS, AND DISCLAIMS ALL WARRANTIES, EXPRESS AND IMPLIED, INCLUDING WITHOUT LIMITATION ANY IMPLIED WARRANTIES OF MERCHANTABILITY, FITNESS FOR A PARTICULAR PURPOSE OR NON-INFRINGEMENT OF THIRD PARTY INTELLECTUAL PROPERTY RIGHTS.

These resources are intended for skilled developers designing with TI products. You are solely responsible for (1) selecting the appropriate TI products for your application, (2) designing, validating and testing your application, and (3) ensuring your application meets applicable standards, and any other safety, security, regulatory or other requirements.

These resources are subject to change without notice. TI grants you permission to use these resources only for development of an application that uses the TI products described in the resource. Other reproduction and display of these resources is prohibited. No license is granted to any other TI intellectual property right or to any third party intellectual property right. TI disclaims responsibility for, and you fully indemnify TI and its representatives against any claims, damages, costs, losses, and liabilities arising out of your use of these resources.

TI's products are provided subject to [TI's Terms of Sale](#), [TI's General Quality Guidelines](#), or other applicable terms available either on ti.com or provided in conjunction with such TI products. TI's provision of these resources does not expand or otherwise alter TI's applicable warranties or warranty disclaimers for TI products. Unless TI explicitly designates a product as custom or customer-specified, TI products are standard, catalog, general purpose devices.

TI objects to and rejects any additional or different terms you may propose.

Copyright © 2026, Texas Instruments Incorporated

Last updated 10/2025