

## SN74LV166A 8-Bit Parallel-Load Shift Registers

### 1 Features

- Operation of 2 V to 5.5 V  $V_{CC}$
- Max  $t_{pd}$  of 10.5 ns at 5 V
- Typical  $V_{OLP}$  (Output Ground Bounce) < 0.8 V at  $V_{CC} = 3.3$  V,  $T_A = 25^\circ\text{C}$
- Typical  $V_{OHV}$  (Output  $V_{OH}$  Undershoot) 2.3 V at  $V_{CC} = 3.3$  V,  $T_A = 25^\circ\text{C}$
- $I_{off}$  supports partial-power-down-mode operation
- Synchronous load
- Direct overriding clear
- Parallel-to-serial conversion
- Latch-up performance exceeds 100 mA per JESD 78, Class II

### 2 Application

- [Input expansion](#)
- 8-bit data storage

### 3 Description

The 'LV166A devices are 8-bit parallel-load shift registers, designed for 2 V to 5.5 V  $V_{CC}$  operation.

#### Package Information

PART NUMBER	PACKAGE <sup>(1)</sup>	BODY SIZE (NOM)
SN74LV166A	D (SOIC, 16)	9.90 mm × 3.90 mm
	DB (SSOP, 16)	6.20 mm × 5.30 mm
	NS (SOP, 16)	10.3 mm × 5.30 mm
	PW (TSSOP, 16)	5.00 mm × 4.40 mm
	DGV (TVSOP, 16)	3.6 mm × 4.4 mm

- (1) For all available packages, see the orderable addendum at the end of the data sheet.

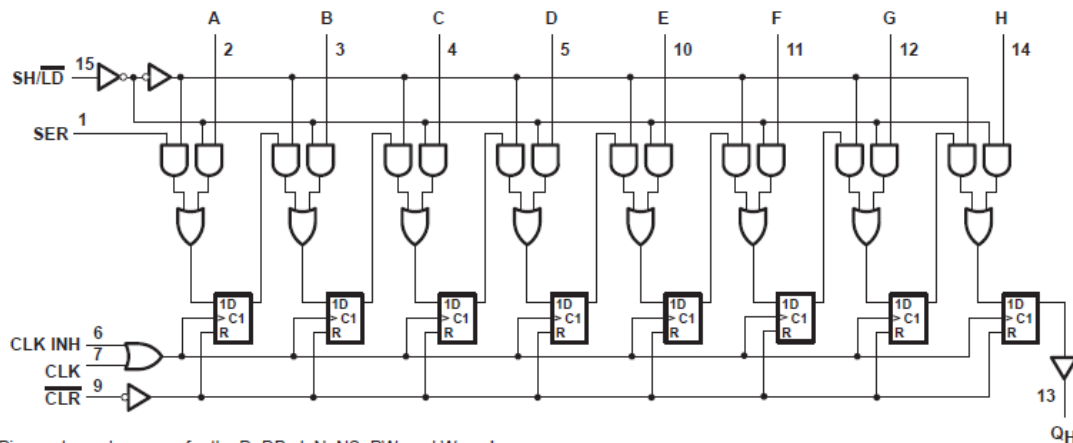

Pin numbers shown are for the D, DB, J, N, NS, PW, and W packages.

**Functional Block Diagram**



## Table of Contents

<b>1 Features</b> .....	1	6.12 Operating Characteristics.....	8
<b>2 Application</b> .....	1	<b>7 Parameter Measurement Information</b> .....	9
<b>3 Description</b> .....	1	<b>8 Detailed Description</b> .....	10
<b>4 Revision History</b> .....	2	8.1 Overview.....	10
<b>5 Pin Configuration and Functions</b> .....	3	8.2 Functional Block Diagram.....	10
<b>6 Specifications</b> .....	4	8.3 Device Functional Modes.....	10
6.1 Absolute Maximum Ratings.....	4	<b>9 Application and Implementation</b> .....	11
6.2 ESD Ratings.....	4	9.1 Power Supply Recommendations.....	11
6.3 Recommended Operating Conditions .....	4	9.2 Layout.....	11
6.4 Thermal Information.....	5	<b>10 Device and Documentation Support</b> .....	12
6.5 Electrical Characteristics.....	5	10.1 Documentation Support.....	12
6.6 Timing Requirements, $V_{CC} = 2.5\text{ V} \pm 0.2\text{ V}$ .....	5	10.2 Receiving Notification of Documentation Updates..	12
6.7 Timing Requirements, $V_{CC} = 3.3\text{ V} \pm 0.3\text{ V}$ .....	6	10.3 Support Resources.....	12
6.8 Timing Requirements, $V_{CC} = 5\text{ V} \pm 0.5\text{ V}$ .....	6	10.4 Electrostatic Discharge Caution.....	12
6.9 Switching Characteristics, $V_{CC} = 2.5\text{ V} \pm 0.2\text{ V}$ .....	6	10.5 Glossary.....	12
6.10 Switching Characteristics, $V_{CC} = 3.3\text{ V} \pm 0.3\text{ V}$ .....	7	<b>11 Mechanical, Packaging, and Orderable Information</b> .....	12
6.11 Switching Characteristics, $V_{CC} = 5\text{ V} \pm 0.5\text{ V}$ .....	7		
Timing Diagram.....	7		

## 4 Revision History

NOTE: Page numbers for previous revisions may differ from page numbers in the current version.

<b>Changes from Revision C (April 2005) to Revision D (March 2023)</b>	<b>Page</b>
• Added <i>Applications</i> , <i>Package Information</i> table, <i>Pin Functions</i> table, <i>ESD Ratings</i> table, <i>Thermal Information</i> table, <i>Device Functional Modes</i> , <i>Application and Implementation</i> section, <i>Power Supply Recommendations</i> section, <i>Layout</i> section, <i>Device and Documentation Support</i> section, and <i>Mechanical, Packaging, and Orderable Information</i> section.....	1

## 5 Pin Configuration and Functions

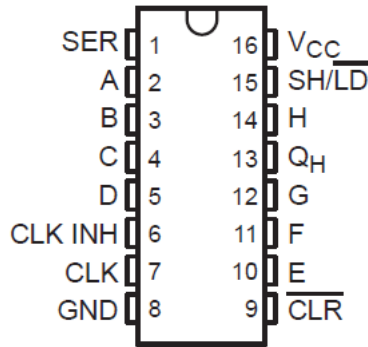

**D, DB, DGV, NS, or PW Package  
16-Pin SOP, SOIC, SSOP, TSSOP, TVSOP  
(Top View)**

**Table 5-1. Pin Functions**

PIN			
NAME	NO.	I/O	DESCRIPTION
SER	1	I	Serial Output
A	2	I	Parallel Input
B	3	I	Parallel Input
C	4	I	Parallel Input
D	5	I	Parallel Input
CLK	7	I	Clock input
GND	8	—	Ground
CLR	9	I	Clear input, active low
E	10	I	Parallel Input
F	11	I	Parallel Input
G	12	I	Parallel Input
Q <sub>H</sub>	13	O	Q <sub>H</sub> output
H	14	I	Parallel input H
SH/ LD	15	I	Shift/ load input, enable shifting when input is high, load data when input is low
V <sub>CC</sub>	16	—	Power Pin

## 6 Specifications

### 6.1 Absolute Maximum Ratings

over operating free-air temperature range (unless otherwise noted)<sup>(1)</sup>

		MIN	MAX	UNIT
V <sub>CC</sub>	Supply voltage range	-0.5	7	V
V <sub>I</sub>	Input voltage range <sup>(1)</sup>	-0.5	7	
V <sub>O</sub>	Output voltage range applied in high or low state, <sup>(1)</sup> <sup>(1)</sup>	-0.5 V	V <sub>CC</sub> + 0.5 V	
V <sub>O</sub>	Voltage range applied to any output in the power-off state <sup>(1)</sup>	-0.5	7	
I <sub>IK</sub>	Input clamp current <sup>(1)</sup>	V <sub>I</sub> < 0	-20	mA
I <sub>OK</sub>	Output clamp current <sup>(1)</sup>	V <sub>O</sub> < 0	-50	mA
I <sub>O</sub>	Continuous output current	V <sub>O</sub> = 0 to V <sub>CC</sub>	±25	mA
	Continuous current through V <sub>CC</sub> or GND		±50	mA
T <sub>stg</sub>	Storage temperature	-65	150	°C

- (1) Stresses beyond those listed under *absolute maximum ratings* may cause permanent damage to the device. These are stress ratings only and functional operation of the device at these or any other conditions beyond those indicated under [Section 6.3](#) is not implied. Exposure to absolute-maximum-rated conditions for extended periods may affect device reliability.

### 6.2 ESD Ratings

			VALUE	UNIT
V <sub>(ESD)</sub>	Electrostatic discharge	Human-Body Model (A114-A) <sup>(1)</sup>	±2000	V
		Charged-Device Model (C101)	±1000	
		Machine Model (A115-A)	±200	

- (1) AEC Q100-002 indicate that HBM stressing shall be in accordance with the ANSI/ESDA/JEDEC JS-001 specification.

### 6.3 Recommended Operating Conditions

		SN74LV166A		UNIT
		MIN	MAX	
V <sub>CC</sub>	Supply voltage	2	5.5	V
V <sub>IH</sub>	High-level input voltage	V <sub>CC</sub> = 2 V	1.5	V
		V <sub>CC</sub> = 2.3 V to 2.7 V	V <sub>CC</sub> × 0.7	
		V <sub>CC</sub> = 3 V to 3.6 V	V <sub>CC</sub> × 0.7	
		V <sub>CC</sub> = 4.5 V to 5.5 V	V <sub>CC</sub> × 0.7	
V <sub>IL</sub>	Low-level input voltage	V <sub>CC</sub> = 2 V	0.5	V
		V <sub>CC</sub> = 2.3 V to 2.7 V	V <sub>CC</sub> × 0.3	
		V <sub>CC</sub> = 3 V to 3.6 V	V <sub>CC</sub> × 0.3	
		V <sub>CC</sub> = 4.5 V to 5.5 V	V <sub>CC</sub> × 0.3	
V <sub>I</sub>	Input voltage	0	5.5	V
V <sub>O</sub>	Output voltage	0	V <sub>CC</sub>	V
I <sub>OH</sub>	High-level output current	V <sub>CC</sub> = 2 V	-50	μA
		V <sub>CC</sub> = 2.3 V to 2.7 V	-2	mA
		V <sub>CC</sub> = 3 V to 3.6 V	-6	
		V <sub>CC</sub> = 4.5 V to 5.5 V	-12	
I <sub>OL</sub>	Low-level output current	V <sub>CC</sub> = 2 V	50	μA
		V <sub>CC</sub> = 2.3 V to 2.7 V	2	mA
		V <sub>CC</sub> = 3 V to 3.6 V	6	
		V <sub>CC</sub> = 4.5 V to 5.5 V	12	

### 6.3 Recommended Operating Conditions (continued)

			SN74LV166A		UNIT
			MIN	MAX	
$\Delta t/\Delta v$	Input transition rise or fall rate	$V_{CC} = 2.3 \text{ V to } 2.7 \text{ V}$		200	ns/V
		$V_{CC} = 3 \text{ V to } 3.6 \text{ V}$		100	
		$V_{CC} = 4.5 \text{ V to } 5.5 \text{ V}$		20	
$T_A$	Operating free-air temperature		-40	85	°C

### 6.4 Thermal Information

THERMAL METRIC		D (SOIC)	DB (SSOP)	DGV (TVSOP)	NS (SO)	PW (TSSOP)	UNIT
		16 PINS	16 PINS	16 PINS	16 PINS	16 PINS	
$R_{\theta JA}$	Junction-to-ambient thermal resistance <sup>(1)</sup>	73	82	120	64	108	°C/W

(1) For more information about traditional and new thermal metrics, see the [Semiconductor and IC package thermal metrics](#) application report.

### 6.5 Electrical Characteristics

over recommended operating free-air temperature range (unless otherwise noted)

PARAMETER	TEST CONDITIONS	$V_{CC}$	SN74LV166A			UNIT
			MIN	TYP	MAX	
$V_{OH}$	$I_{OH} = -50 \mu\text{A}$	2 V to 5.5 V	$V_{CC}-0.1$			V
	$I_{OH} = -2 \text{ mA}$	2.3 V	2			
	$I_{OH} = -50 \mu\text{A}$	3 V	2.48			
	$I_{OH} = -6 \text{ mA}$	4.5 V	3.8			
$V_{OL}$	$I_{OH} = -12 \text{ mA}$	2 V to 5.5 V			0.1	V
		2.3 V			0.4	
		3 V			0.44	
	$I_{OL} = 4 \text{ mA}$	4.5 V			0.55	
$I_I$	$V_I = V_{CC}$ or 0	0 to 5.5 V			$\pm 1$	$\mu\text{A}$
$I_{CC}$	$V_I = V_{CC}$ or 0, $I_O = 0$	5.5 V			20	$\mu\text{A}$
$I_{off}$		0			5	$\mu\text{A}$
$C_i$		3.3 V		1.6		pF

### 6.6 Timing Requirements, $V_{CC} = 2.5 \text{ V} \pm 0.2 \text{ V}$

over recommended operating free-air temperature range,  $V_{CC} = 2.5 \text{ V} \pm 0.2 \text{ V}$  (unless otherwise noted)

			$T_A = 25^\circ\text{C}$		SN74LV166A		UNIT
			MIN	MAX	MIN	MAX	
$t_w$	Pulse duration	$\overline{\text{CLR}}$ low	8		9		ns
		CLK high or low	8.5		9		
$t_{su}$	Setup time	CLK INH before CLK $\uparrow$	7		7		ns
		Data before CLK $\uparrow$	6.5		8.5		
		SH/ $\overline{\text{LD}}$ before CLK $\uparrow$	7		8.5		
		SER before CLK $\uparrow$	8.5		9.5		
		$\overline{\text{CLR}}$ $\uparrow$ inactive before CLK $\uparrow$	6		7		
$t_h$	Hold time	Data after CLK $\uparrow$	-0.5		0		ns

### 6.7 Timing Requirements, $V_{CC} = 3.3\text{ V} \pm 0.3\text{ V}$

over recommended operating free-air temperature range,  $V_{CC} = 3.3\text{ V} \pm 0.3\text{ V}$  (unless otherwise noted)

			$T_A = 25^\circ\text{C}$		SN74LV166A		UNIT
			MIN	MAX	MIN	MAX	
$t_w$	Pulse duration	CLR low	6		7		ns
		CLK high or low	6		7		
$t_{su}$	Setup time	CLK INH before CLK $\uparrow$	5		5		ns
		Data before CLK $\uparrow$	5		6		
		SH/ $\overline{\text{LD}}$ before CLK $\uparrow$	5		6		
		SER before CLK $\uparrow$	5		6		
		$\overline{\text{CLR}}\uparrow$ inactive before CLK $\uparrow$	4		4		
$t_h$	Hold time	Data after CLK $\uparrow$	0		0		ns

### 6.8 Timing Requirements, $V_{CC} = 5\text{ V} \pm 0.5\text{ V}$

over recommended operating free-air temperature range,  $V_{CC} = 5\text{ V} \pm 0.5\text{ V}$  (unless otherwise noted)

			$T_A = 25^\circ\text{C}$		SN74LV166A		UNIT
			MIN	MAX	MIN	MAX	
$t_w$	Pulse duration	CLR low	5		5		ns
		CLK high or low	4		4		
$t_{su}$	Setup time	CLK INH before CLK $\uparrow$	3.5		3.5		ns
		Data before CLK $\uparrow$	4.5		4.5		
		SH/ $\overline{\text{LD}}$ before CLK $\uparrow$	4		4		
		SER before CLK $\uparrow$	4		4		
		$\overline{\text{CLR}}\uparrow$ inactive before CLK $\uparrow$	3.5		3.5		
$t_h$	Hold time	Data after CLK $\uparrow$	1		1		ns

### 6.9 Switching Characteristics, $V_{CC} = 2.5\text{ V} \pm 0.2\text{ V}$

over recommended operating free-air temperature range,  $V_{CC} = 2.5\text{ V} \pm 0.2\text{ V}$  (unless otherwise noted) (see [Figure 6](#))

PARAMETER	FROM (INPUT)	TO (OUTPUT)	TEST CONDITIONS	$T_A = 25^\circ\text{C}$			SN74LV166A		UNIT
				MIN	TYP	MAX	MIN	MAX	
$f_{max}$			$C_L = 15\text{ pF}$	50 <sup>1</sup>	105 <sup>1</sup>		45		MHz
			$C_L = 50\text{ pF}$	40	80		35		
$t_{PHL}$	$\overline{\text{CLR}}$	$Q_H$	$C_L = 15\text{ pF}$		8.8 <sup>1</sup>	16 <sup>1</sup>	1	18	ns
$t_{pd}$	CLK				9.2 <sup>1</sup>	19.8 <sup>1</sup>	1	22	
$t_{PHL}$	$\overline{\text{CLR}}$	$Q_H$	$C_L = 50\text{ pF}$		11.3	19.5	1	22	ns
$t_{pd}$	CLK				11.8	23.3	1	26	

1. On products compliant to MIL-PRF-38535, this parameter is not production tested.

### 6.10 Switching Characteristics, $V_{CC} = 3.3\text{ V} \pm 0.3\text{ V}$

over recommended operating free-air temperature range,  $V_{CC} = 3.3\text{ V} \pm 0.3\text{ V}$  (unless otherwise noted) (see Figure 6)

PARAMETER	FROM (INPUT)	TO (OUTPUT)	TEST CONDITIONS	$T_A = 25^\circ\text{C}$			SN74LV166A		UNIT
				MIN	TYP	MAX	MIN	MAX	
$f_{\text{max}}$			$C_L = 15\text{ pF}$	65 <sup>1</sup>	150 <sup>1</sup>		55		MHz
			$C_L = 50\text{ pF}$	60	120		50		
$t_{\text{PHL}}$	$\overline{\text{CLR}}$	$Q_H$	$C_L = 15\text{ pF}$		6.3 <sup>1</sup>	12.5 <sup>1</sup>	1	15	ns
$t_{\text{pd}}$	CLK				6.6 <sup>1</sup>	15.4 <sup>1</sup>	1	18	
$t_{\text{PHL}}$	$\overline{\text{CLR}}$	$Q_H$	$C_L = 50\text{ pF}$		7.9	16.3	1	18.5	ns
$t_{\text{pd}}$	CLK				8.3	18.9	1	21.5	

1. On products compliant to MIL-PRF-38535, this parameter is not production tested.

### 6.11 Switching Characteristics, $V_{CC} = 5\text{ V} \pm 0.5\text{ V}$

over recommended operating free-air temperature range,  $V_{CC} = 5\text{ V} \pm 0.5\text{ V}$  (unless otherwise noted) (see Figure 6)

PARAMETER	FROM (INPUT)	TO (OUTPUT)	TEST CONDITIONS	$T_A = 25^\circ\text{C}$			SN74LV166A		UNIT
				MIN	TYP	MAX	MIN	MAX	
$f_{\text{max}}$			$C_L = 15\text{ pF}$	110 <sup>1</sup>	205 <sup>1</sup>		90		MHz
			$C_L = 50\text{ pF}$	95	160		85		
$t_{\text{PHL}}$	$\overline{\text{CLR}}$	$Q_H$	$C_L = 15\text{ pF}$		4.6 <sup>1</sup>	8.6 <sup>1</sup>	1	10	ns
$t_{\text{pd}}$	CLK				4.8 <sup>1</sup>	9.9 <sup>1</sup>	1	11.5	
$t_{\text{PHL}}$	$\overline{\text{CLR}}$	$Q_H$	$C_L = 50\text{ pF}$		5.7	10.6	1	12	ns
$t_{\text{pd}}$	CLK				6.1	11.9	1	13.5	

1. On products compliant to MIL-PRF-38535, this parameter is not production tested.

### Timing Diagram

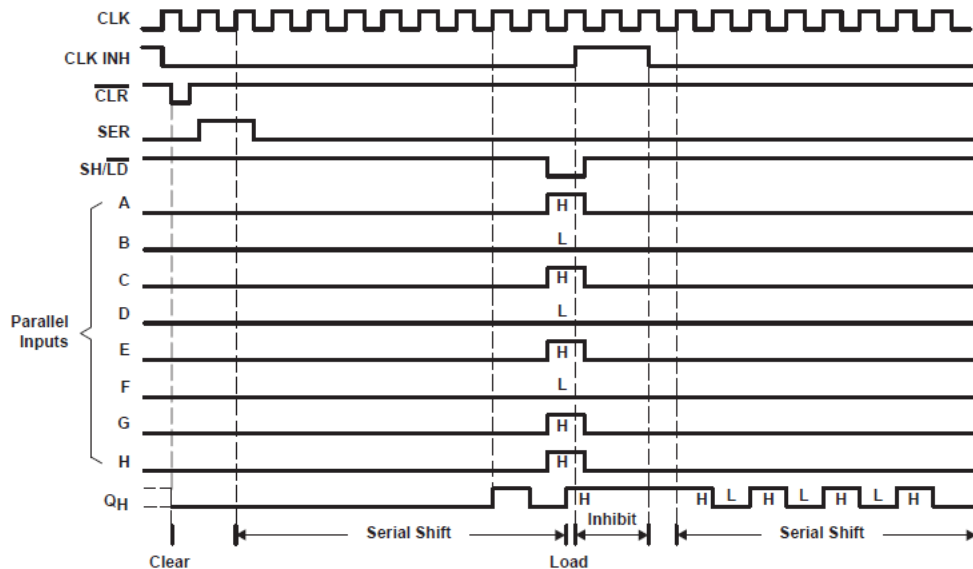

Figure 6-1. Typical Clear, Shift, Load, Inhibit, and Shift Sequence

## 6.12 Operating Characteristics

$T_A = 25^\circ\text{C}$

PARAMETER		TEST CONDITIONS		$V_{CC}$	TYP	UNIT
$C_{pd}$	Power dissipation capacitance	$C_L = 50 \text{ pF}$	$f = 10 \text{ MHz}$	3.3 V	39.1	pF
				5 V	44.5	



## 7 Parameter Measurement Information

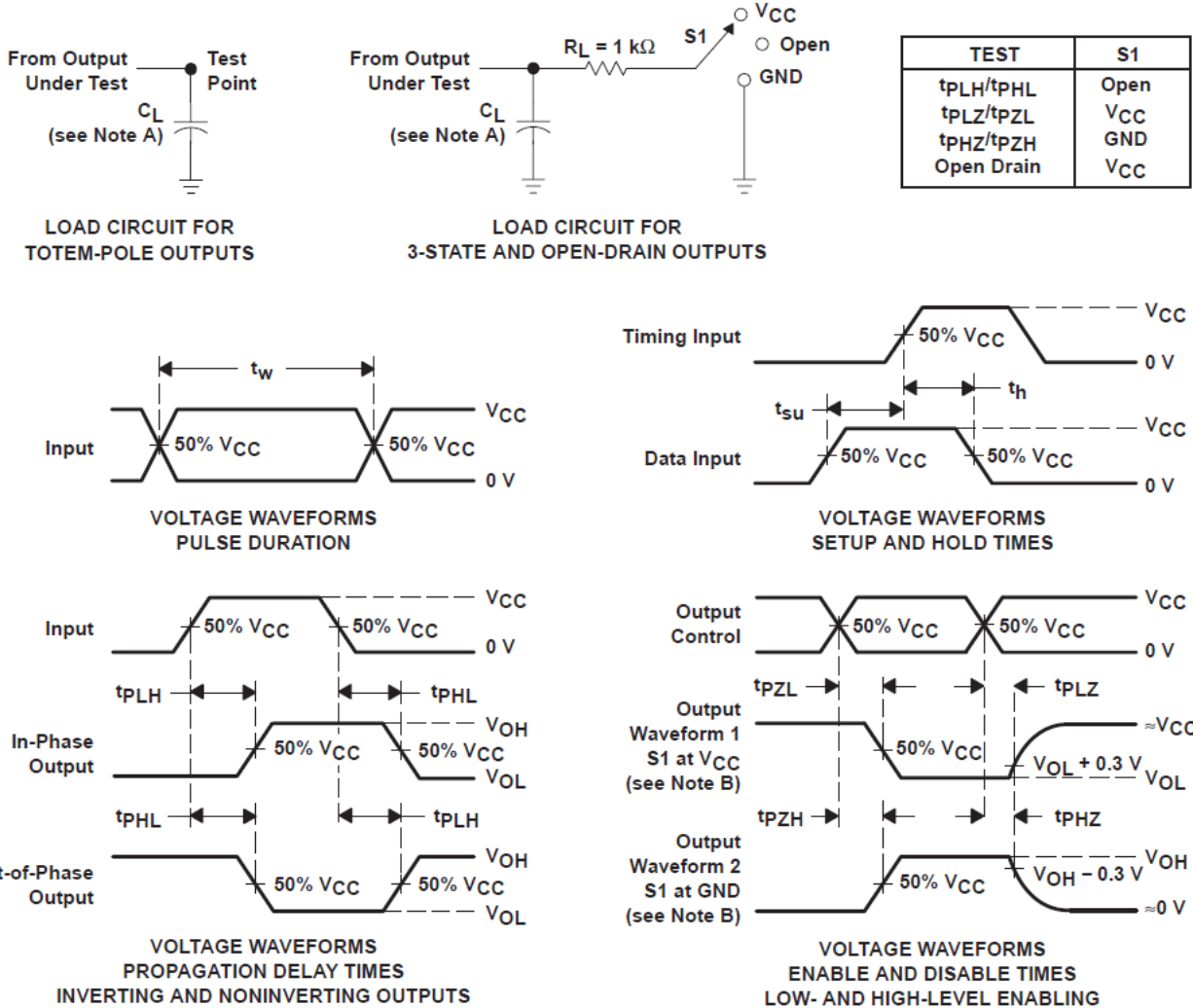

A.  $C_L$  includes probe and jig capacitance.

B. Phase relationships between waveforms were chosen arbitrarily. All input pulses are supplied by generators having the following characteristics:  $PRR \leq 1\text{ MHz}$ ,  $Z_O = 50\ \Omega$ ,  $t_r = 6\text{ ns}$ ,  $t_f = 6\text{ ns}$ .

C. For clock inputs,  $f_{max}$  is measured when the input duty cycle is 50%

D. The outputs are measured one at a time with one input transition per measurement.

E.  $t_{PLZ}$  and  $t_{PHZ}$  are the same as  $t_{dis}$ .

F.  $t_{PZL}$  and  $t_{PZH}$  are the same as  $t_{en}$ .

G.  $t_{PHL}$  and  $t_{PLH}$  are the same as  $t_{pd}$ .

H. All parameters and waveforms are not applicable to all devices.

## 8 Detailed Description

### 8.1 Overview

These parallel-in or serial-in, serial-out registers feature gated clock (CLK, CLK INH) inputs and an overriding clear ( $\overline{\text{CLR}}$ ) input. The parallel-in or serial-in modes are established by the shift/load ( $\overline{\text{SH/LD}}$ ) input. When high,  $\overline{\text{SH/LD}}$  enables the serial (SER) data input and couples the eight flip-flops for serial shifting with each clock (CLK) pulse. When low, the parallel (broadside) data inputs are enabled, and synchronous loading occurs on the next clock pulse. During parallel loading, serial data flow is inhibited.

Clocking is accomplished on the low-to-high-level edge of CLK through a 2-input positive-NOR gate, permitting one input to be used as a clock-enable or clock-inhibit function. Holding either CLK or CLK INH high inhibits clocking; holding either low enables the other clock input. This allows the system clock to be free running, and the register can be stopped on command with the other clock input. CLK INH should be changed to the high level only when CLK is high.  $\overline{\text{CLR}}$  overrides all other inputs, including CLK, and resets all flip-flops to zero.

These devices are fully specified for partial-power-down applications using  $I_{\text{off}}$ . The  $I_{\text{off}}$  circuitry disables the outputs, preventing damaging current backflow through the devices when they are powered down.

### 8.2 Functional Block Diagram

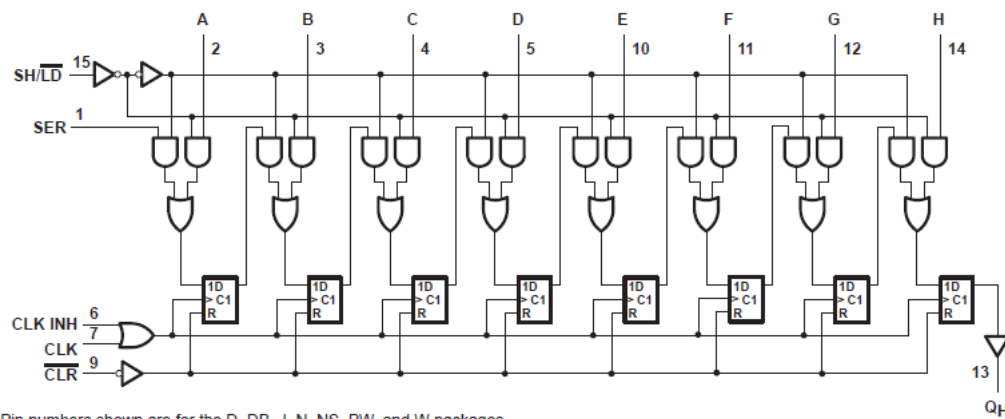

Pin numbers shown are for the D, DB, J, N, NS, PW, and W packages.

### 8.3 Device Functional Modes

Table 8-1. Function Table

INPUTS						OUTPUTS		
$\overline{\text{CLR}}$	$\overline{\text{SH/LD}}$	CLK INH	CLK	SER	PARALLEL A...H	INTERNAL		$Q_H$
						$Q_A$	$Q_B$	
L	X	X	X	X	X	L	L	L
H	X	L	L	X	X	$Q_{A0}$	$Q_{B0}$	$Q_{H0}$
H	L	L	↑	X	a...h	a	b	h
H	H	L	↑	H	X	H	$Q_{An}$	$Q_{Gn}$
H	H	L	↑	L	X	L	$Q_{An}$	$Q_{Gn}$
H	X	H	↑	X	X	$Q_{A0}$	$Q_{B0}$	$Q_{H0}$

## 9 Application and Implementation

### Note

Information in the following applications sections is not part of the TI component specification, and TI does not warrant its accuracy or completeness. TI's customers are responsible for determining suitability of components for their purposes, as well as validating and testing their design implementation to confirm system functionality.

### 9.1 Power Supply Recommendations

The power supply can be any voltage between the minimum and maximum supply voltage rating located in the [Section 6.1](#) table. Each  $V_{CC}$  terminal should have a bypass capacitor to prevent power disturbance. For this device, a 0.1- $\mu\text{F}$  capacitor is recommended. It is acceptable to parallel multiple bypass caps to reject different frequencies of noise. The 0.1- $\mu\text{F}$  and 1- $\mu\text{F}$  capacitors are commonly used in parallel. The bypass capacitor should be installed as close to the power terminals as possible for best results.

### 9.2 Layout

#### 9.2.1 Layout Guidelines

In many cases, functions or parts of functions of digital logic devices are unused. Some examples are when only two inputs of a triple-input AND gate are used, or when only 3 of the 4 channels are used. Such input pins should not be left completely unconnected because the unknown voltages result in undefined operational states.

Specified in [Section 9.2.1.1](#) are rules that must be observed under all circumstances. All unused inputs of digital logic devices must be connected to a high or low bias to prevent them from floating. The logic level that must be applied to any particular unused input depends on the function of the device. Generally they are tied to GND or  $V_{CC}$ , whichever makes more sense or is more convenient. It is recommended to float outputs unless the part is a transceiver. If the transceiver has an output enable pin, it disables the output section of the part when asserted. This pin keeps the input section of the I/Os from being disabled and floated.

#### 9.2.1.1 Layout Example

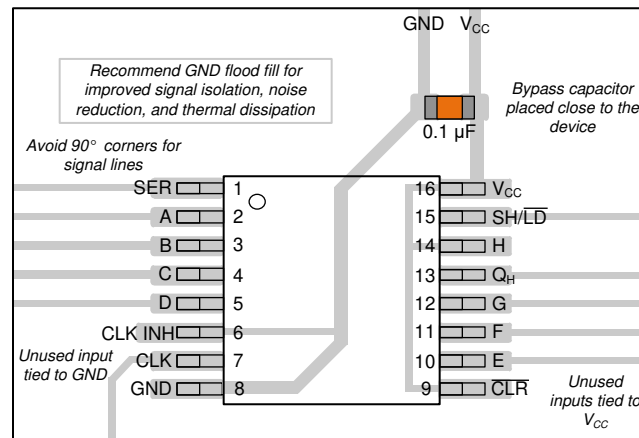

Figure 9-1. Layout Example

## 10 Device and Documentation Support

TI offers an extensive line of development tools. Tools and software to evaluate the performance of the device, generate code, and develop solutions are listed below.

### 10.1 Documentation Support

#### 10.1.1 Related Documentation

The table below lists quick access links. Categories include technical documents, support and community resources, tools and software, and quick access to sample or buy.

**Table 10-1. Related Links**

PARTS	PRODUCT FOLDER	SAMPLE & BUY	TECHNICAL DOCUMENTS	TOOLS & SOFTWARE	SUPPORT & COMMUNITY
SN74LV166A	<a href="#">Click here</a>	<a href="#">Click here</a>	<a href="#">Click here</a>	<a href="#">Click here</a>	<a href="#">Click here</a>

### 10.2 Receiving Notification of Documentation Updates

To receive notification of documentation updates—including silicon errata—go to the product folder for your device on [ti.com](#). In the upper right-hand corner, click the *Alert me* button. This registers you to receive a weekly digest of product information that has changed (if any). For change details, check the revision history of any revised document.

### 10.3 Support Resources

[TI E2E™ support forums](#) are an engineer's go-to source for fast, verified answers and design help — straight from the experts. Search existing answers or ask your own question to get the quick design help you need.

Linked content is provided "AS IS" by the respective contributors. They do not constitute TI specifications and do not necessarily reflect TI's views; see TI's [Terms of Use](#).

### Trademarks

TI E2E™ is a trademark of Texas Instruments.

All trademarks are the property of their respective owners.

### 10.4 Electrostatic Discharge Caution



This integrated circuit can be damaged by ESD. Texas Instruments recommends that all integrated circuits be handled with appropriate precautions. Failure to observe proper handling and installation procedures can cause damage.

ESD damage can range from subtle performance degradation to complete device failure. Precision integrated circuits may be more susceptible to damage because very small parametric changes could cause the device not to meet its published specifications.

### 10.5 Glossary

[TI Glossary](#) This glossary lists and explains terms, acronyms, and definitions.

## 11 Mechanical, Packaging, and Orderable Information

The following pages include mechanical, packaging, and orderable information. This information is the most current data available for the designated devices. This data is subject to change without notice and revision of this document. For browser-based versions of this data sheet, refer to the left-hand navigation.

**PACKAGING INFORMATION**

Orderable part number	Status (1)	Material type (2)	Package   Pins	Package qty   Carrier	RoHS (3)	Lead finish/ Ball material (4)	MSL rating/ Peak reflow (5)	Op temp (°C)	Part marking (6)
<a href="#">SN74LV166AD</a>	Obsolete	Production	SOIC (D)   16	-	-	Call TI	Call TI	-40 to 85	LV166A
<a href="#">SN74LV166ADBR</a>	Active	Production	SSOP (DB)   16	2000   LARGE T&R	Yes	NIPDAU	Level-1-260C-UNLIM	-40 to 85	LV166A
SN74LV166ADBR.A	Active	Production	SSOP (DB)   16	2000   LARGE T&R	Yes	NIPDAU	Level-1-260C-UNLIM	-40 to 85	LV166A
<a href="#">SN74LV166ADGVR</a>	Active	Production	TVSOP (DGV)   16	2000   LARGE T&R	Yes	NIPDAU	Level-1-260C-UNLIM	-40 to 85	LV166A
SN74LV166ADGVR.A	Active	Production	TVSOP (DGV)   16	2000   LARGE T&R	Yes	NIPDAU	Level-1-260C-UNLIM	-40 to 85	LV166A
<a href="#">SN74LV166ADR</a>	Active	Production	SOIC (D)   16	2500   LARGE T&R	Yes	NIPDAU	Level-1-260C-UNLIM	-40 to 85	LV166A
SN74LV166ADR.A	Active	Production	SOIC (D)   16	2500   LARGE T&R	Yes	NIPDAU	Level-1-260C-UNLIM	-40 to 85	LV166A
<a href="#">SN74LV166ANSR</a>	Active	Production	SOP (NS)   16	2000   LARGE T&R	Yes	NIPDAU	Level-1-260C-UNLIM	-40 to 85	74LV166A
SN74LV166ANSR.A	Active	Production	SOP (NS)   16	2000   LARGE T&R	Yes	NIPDAU	Level-1-260C-UNLIM	-40 to 85	74LV166A
<a href="#">SN74LV166APW</a>	Obsolete	Production	TSSOP (PW)   16	-	-	Call TI	Call TI	-40 to 85	LV166A
<a href="#">SN74LV166APWR</a>	Active	Production	TSSOP (PW)   16	2000   LARGE T&R	Yes	NIPDAU   SN	Level-1-260C-UNLIM	-40 to 85	LV166A
SN74LV166APWR.A	Active	Production	TSSOP (PW)   16	2000   LARGE T&R	Yes	NIPDAU	Level-1-260C-UNLIM	-40 to 85	LV166A

(1) **Status:** For more details on status, see our [product life cycle](#).

(2) **Material type:** When designated, preproduction parts are prototypes/experimental devices, and are not yet approved or released for full production. Testing and final process, including without limitation quality assurance, reliability performance testing, and/or process qualification, may not yet be complete, and this item is subject to further changes or possible discontinuation. If available for ordering, purchases will be subject to an additional waiver at checkout, and are intended for early internal evaluation purposes only. These items are sold without warranties of any kind.

(3) **RoHS values:** Yes, No, RoHS Exempt. See the [TI RoHS Statement](#) for additional information and value definition.

(4) **Lead finish/Ball material:** Parts may have multiple material finish options. Finish options are separated by a vertical ruled line. Lead finish/Ball material values may wrap to two lines if the finish value exceeds the maximum column width.

(5) **MSL rating/Peak reflow:** The moisture sensitivity level ratings and peak solder (reflow) temperatures. In the event that a part has multiple moisture sensitivity ratings, only the lowest level per JEDEC standards is shown. Refer to the shipping label for the actual reflow temperature that will be used to mount the part to the printed circuit board.

(6) **Part marking:** There may be an additional marking, which relates to the logo, the lot trace code information, or the environmental category of the part.

Multiple part markings will be inside parentheses. Only one part marking contained in parentheses and separated by a "-" will appear on a part. If a line is indented then it is a continuation of the previous line and the two combined represent the entire part marking for that device.

**Important Information and Disclaimer:** The information provided on this page represents TI's knowledge and belief as of the date that it is provided. TI bases its knowledge and belief on information provided by third parties, and makes no representation or warranty as to the accuracy of such information. Efforts are underway to better integrate information from third parties. TI has taken and continues to take reasonable steps to provide representative and accurate information but may not have conducted destructive testing or chemical analysis on incoming materials and chemicals. TI and TI suppliers consider certain information to be proprietary, and thus CAS numbers and other limited information may not be available for release.

In no event shall TI's liability arising out of such information exceed the total purchase price of the TI part(s) at issue in this document sold by TI to Customer on an annual basis.

**TAPE AND REEL INFORMATION**

**QUADRANT ASSIGNMENTS FOR PIN 1 ORIENTATION IN TAPE**

\*All dimensions are nominal

Device	Package Type	Package Drawing	Pins	SPQ	Reel Diameter (mm)	Reel Width W1 (mm)	A0 (mm)	B0 (mm)	K0 (mm)	P1 (mm)	W (mm)	Pin1 Quadrant
SN74LV166ADBR	SSOP	DB	16	2000	330.0	16.4	8.35	6.6	2.4	12.0	16.0	Q1
SN74LV166ADGVR	TVSOP	DGV	16	2000	330.0	12.4	6.8	4.0	1.6	8.0	12.0	Q1
SN74LV166ADR	SOIC	D	16	2500	330.0	16.4	6.5	10.3	2.1	8.0	16.0	Q1
SN74LV166ANSR	SOP	NS	16	2000	330.0	16.4	8.1	10.4	2.5	12.0	16.0	Q1
SN74LV166APWR	TSSOP	PW	16	2000	330.0	12.4	6.9	5.6	1.6	8.0	12.0	Q1

**TAPE AND REEL BOX DIMENSIONS**

\*All dimensions are nominal

Device	Package Type	Package Drawing	Pins	SPQ	Length (mm)	Width (mm)	Height (mm)
SN74LV166ADBR	SSOP	DB	16	2000	353.0	353.0	32.0
SN74LV166ADGVR	TVSOP	DGV	16	2000	353.0	353.0	32.0
SN74LV166ADR	SOIC	D	16	2500	340.5	336.1	32.0
SN74LV166ANSR	SOP	NS	16	2000	353.0	353.0	32.0
SN74LV166APWR	TSSOP	PW	16	2000	353.0	353.0	32.0





# PACKAGE OUTLINE

## NS0016A

### SOP - 2.00 mm max height

SOP



4220735/A 12/2021

#### NOTES:

1. All linear dimensions are in millimeters. Dimensions in parenthesis are for reference only. Dimensioning and tolerancing per ASME Y14.5M.
2. This drawing is subject to change without notice.
3. This dimension does not include mold flash, protrusions, or gate burrs. Mold flash, protrusions, or gate burrs shall not exceed 0.15 mm, per side.
4. This dimension does not include interlead flash. Interlead flash shall not exceed 0.25 mm, per side.

# EXAMPLE BOARD LAYOUT

NS0016A

SOP - 2.00 mm max height

SOP



4220735/A 12/2021

NOTES: (continued)

5. Publication IPC-7351 may have alternate designs.

6. Solder mask tolerances between and around signal pads can vary based on board fabrication site.

# EXAMPLE STENCIL DESIGN

NS0016A

SOP - 2.00 mm max height

SOP



SOLDER PASTE EXAMPLE  
BASED ON 0.125 mm THICK STENCIL  
SCALE:7X

4220735/A 12/2021

NOTES: (continued)

7. Laser cutting apertures with trapezoidal walls and rounded corners may offer better paste release. IPC-7525 may have alternate design recommendations.
8. Board assembly site may have different recommendations for stencil design.

D (R-PDSO-G16)

PLASTIC SMALL OUTLINE



- NOTES:
- A. All linear dimensions are in inches (millimeters).
  - B. This drawing is subject to change without notice.
  - C. Body length does not include mold flash, protrusions, or gate burrs. Mold flash, protrusions, or gate burrs shall not exceed 0.006 (0,15) each side.
  - D. Body width does not include interlead flash. Interlead flash shall not exceed 0.017 (0,43) each side.
  - E. Reference JEDEC MS-012 variation AC.

# DB0016A



# PACKAGE OUTLINE

## SSOP - 2 mm max height

SMALL OUTLINE PACKAGE



4220763/A 05/2022

### NOTES:

1. All linear dimensions are in millimeters. Any dimensions in parenthesis are for reference only. Dimensioning and tolerancing per ASME Y14.5M.
2. This drawing is subject to change without notice.
3. This dimension does not include mold flash, protrusions, or gate burrs. Mold flash, protrusions, or gate burrs shall not exceed 0.15 mm per side.
4. Reference JEDEC registration MO-150.

# EXAMPLE BOARD LAYOUT

DB0016A

SSOP - 2 mm max height

SMALL OUTLINE PACKAGE



LAND PATTERN EXAMPLE  
EXPOSED METAL SHOWN  
SCALE: 10X



4220763/A 05/2022

NOTES: (continued)

- 5. Publication IPC-7351 may have alternate designs.
- 6. Solder mask tolerances between and around signal pads can vary based on board fabrication site.

# EXAMPLE STENCIL DESIGN

DB0016A

SSOP - 2 mm max height

SMALL OUTLINE PACKAGE



SOLDER PASTE EXAMPLE  
BASED ON 0.125 mm THICK STENCIL  
SCALE: 10X

4220763/A 05/2022

NOTES: (continued)

7. Laser cutting apertures with trapezoidal walls and rounded corners may offer better paste release. IPC-7525 may have alternate design recommendations.
8. Board assembly site may have different recommendations for stencil design.

DGV (R-PDSO-G\*\*)

PLASTIC SMALL-OUTLINE

24 PINS SHOWN



- NOTES: A. All linear dimensions are in millimeters.  
 B. This drawing is subject to change without notice.  
 C. Body dimensions do not include mold flash or protrusion, not to exceed 0,15 per side.  
 D. Falls within JEDEC: 24/48 Pins – MO-153  
 14/16/20/56 Pins – MO-194





4220204/B 12/2023

NOTES:

1. All linear dimensions are in millimeters. Any dimensions in parenthesis are for reference only. Dimensioning and tolerancing per ASME Y14.5M.
2. This drawing is subject to change without notice.
3. This dimension does not include mold flash, protrusions, or gate burrs. Mold flash, protrusions, or gate burrs shall not exceed 0.15 mm per side.
4. This dimension does not include interlead flash. Interlead flash shall not exceed 0.25 mm per side.
5. Reference JEDEC registration MO-153.

# EXAMPLE BOARD LAYOUT

PW0016A

TSSOP - 1.2 mm max height

SMALL OUTLINE PACKAGE



LAND PATTERN EXAMPLE  
EXPOSED METAL SHOWN  
SCALE: 10X



SOLDER MASK DETAILS

4220204/B 12/2023

NOTES: (continued)

- 6. Publication IPC-7351 may have alternate designs.
- 7. Solder mask tolerances between and around signal pads can vary based on board fabrication site.

# EXAMPLE STENCIL DESIGN

PW0016A

TSSOP - 1.2 mm max height

SMALL OUTLINE PACKAGE



SOLDER PASTE EXAMPLE  
BASED ON 0.125 mm THICK STENCIL  
SCALE: 10X

4220204/B 12/2023

NOTES: (continued)

8. Laser cutting apertures with trapezoidal walls and rounded corners may offer better paste release. IPC-7525 may have alternate design recommendations.
9. Board assembly site may have different recommendations for stencil design.

## IMPORTANT NOTICE AND DISCLAIMER

TI PROVIDES TECHNICAL AND RELIABILITY DATA (INCLUDING DATASHEETS), DESIGN RESOURCES (INCLUDING REFERENCE DESIGNS), APPLICATION OR OTHER DESIGN ADVICE, WEB TOOLS, SAFETY INFORMATION, AND OTHER RESOURCES "AS IS" AND WITH ALL FAULTS, AND DISCLAIMS ALL WARRANTIES, EXPRESS AND IMPLIED, INCLUDING WITHOUT LIMITATION ANY IMPLIED WARRANTIES OF MERCHANTABILITY, FITNESS FOR A PARTICULAR PURPOSE OR NON-INFRINGEMENT OF THIRD PARTY INTELLECTUAL PROPERTY RIGHTS.

These resources are intended for skilled developers designing with TI products. You are solely responsible for (1) selecting the appropriate TI products for your application, (2) designing, validating and testing your application, and (3) ensuring your application meets applicable standards, and any other safety, security, regulatory or other requirements.

These resources are subject to change without notice. TI grants you permission to use these resources only for development of an application that uses the TI products described in the resource. Other reproduction and display of these resources is prohibited. No license is granted to any other TI intellectual property right or to any third party intellectual property right. TI disclaims responsibility for, and you fully indemnify TI and its representatives against any claims, damages, costs, losses, and liabilities arising out of your use of these resources.

TI's products are provided subject to [TI's Terms of Sale](#), [TI's General Quality Guidelines](#), or other applicable terms available either on [ti.com](http://ti.com) or provided in conjunction with such TI products. TI's provision of these resources does not expand or otherwise alter TI's applicable warranties or warranty disclaimers for TI products. Unless TI explicitly designates a product as custom or customer-specified, TI products are standard, catalog, general purpose devices.

TI objects to and rejects any additional or different terms you may propose.

Copyright © 2025, Texas Instruments Incorporated

Last updated 10/2025