

SN74LVC244A Octal Buffer or Driver With 3-State Outputs

1 Features

- Operates from 1.65V to 3.6V
- Inputs accept voltages to 5.5V
- Specified from -40°C to $+85^{\circ}\text{C}$ and -40°C to $+125^{\circ}\text{C}$
- Maximum t_{pd} of 5.9ns at 3.3V
- Typical V_{OLP} (output ground bounce) $< 0.8\text{V}$ at $V_{CC} = 3.3\text{V}$, $T_A = 25^{\circ}\text{C}$
- Typical V_{OHV} (output V_{OH} undershoot) $> 2\text{V}$ at $V_{CC} = 3.3\text{V}$, $T_A = 25^{\circ}\text{C}$
- Supports mixed-mode signal operation on all ports (5V input or output voltage with 3.3V V_{CC})
- I_{off} supports live insertion, partial-power-down mode, and back-drive protection
- Can be used as a down translator to translate inputs from a maximum of 5.5V down to the V_{CC} level
- Available in ultra small logic QFN package (0.5mm maximum height)
- Latch-up performance exceeds 250mA per JESD 17

2 Applications

- Servers
- LED displays
- Network switches
- Telecom infrastructure
- Motor drivers
- I/O expanders
- [Enable or disable a digital signal](#)
- [Controlling an indicator LED](#)
- [Translation between communication modules and system controllers](#)

3 Description

These octal bus buffers are designed for 1.65V to 3.6V V_{CC} operation. The SN74LVC244A devices are designed for asynchronous communication between data buses.

Package Information

PART NUMBER	PACKAGE ⁽¹⁾	PACKAGE SIZE ⁽²⁾	BODY SIZE ⁽³⁾
SN74LVC244A	RKS (VQFN, 20)	4.50mm × 2.50mm	4.50mm × 2.50mm
	N (PDIP, 20)	24.33mm × 9.4mm	24.33mm × 6.35mm
	NS (SOP, 20)	12.60mm × 7.8mm	12.60mm × 5.30mm
	DB (SSOP, 20)	7.2mm × 7.8mm	7.2mm × 5.30mm
	DGV (TVSOP, 20)	5.00mm × 6.4mm	5.00mm × 4.4mm
	DW (SOIC, 20)	12.80mm × 10.3mm	12.80mm × 7.50mm
	RGY (VQFN, 20)	4.50mm × 3.50mm	4.50mm × 3.50mm
	ZQN (BGA, 20)	4.00mm × 3.00mm	4.00mm × 3.00mm
	PW (TSSOP, 20)	6.50mm × 6.4mm	6.50mm × 4.40mm
	RWP (X1QFN, 20)	3.30mm × 2.50mm	3.30mm × 2.50mm
	DGS (VSSOP, 20)	5.10mm × 4.90mm	5.10mm × 3.00mm

- For more information, see [Mechanical, Packaging, and Orderable Information](#).
- The package size (length × width) is a nominal value and includes pins, where applicable.
- The body size (length × width) is a nominal value and does not include pins.

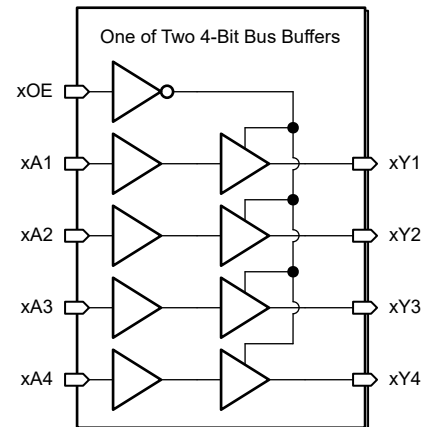

Logic Diagram (Positive Logic)



Table of Contents

1 Features	1	7.3 Feature Description.....	11
2 Applications	1	7.4 Device Functional Modes.....	12
3 Description	1	8 Application and Implementation	13
4 Pin Configuration and Functions	3	8.1 Application Information.....	13
5 Specifications	5	8.2 Typical Application.....	13
5.1 Absolute Maximum Ratings.....	5	8.3 Power Supply Recommendations.....	14
5.2 ESD Ratings.....	5	8.4 Layout.....	14
5.3 Recommended Operating Conditions.....	6	9 Device and Documentation Support	16
5.4 Thermal Information.....	6	9.1 Documentation Support.....	16
5.5 Electrical Characteristics.....	7	9.2 Receiving Notification of Documentation Updates....	16
5.6 Switching Characteristics.....	8	9.3 Support Resources.....	16
5.7 Operating Characteristics.....	8	9.4 Trademarks.....	16
5.8 Typical Characteristics.....	9	9.5 Electrostatic Discharge Caution.....	16
6 Parameter Measurement Information	10	9.6 Glossary.....	16
7 Detailed Description	11	10 Revision History	16
7.1 Overview.....	11	11 Mechanical, Packaging, and Orderable Information	17
7.2 Functional Block Diagram.....	11		

4 Pin Configuration and Functions

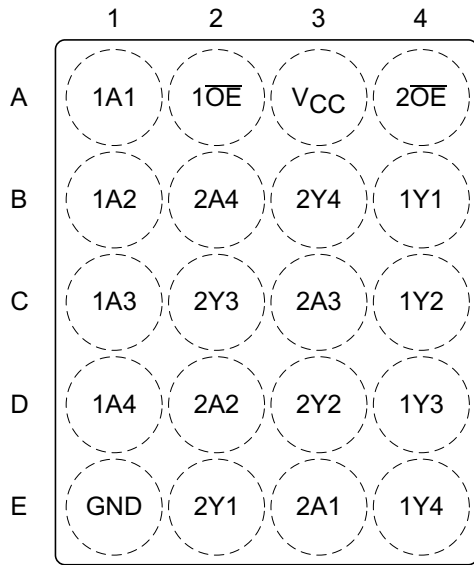

Not to scale

Figure 4-1. ZQN Package 20-Pin BGA Top View

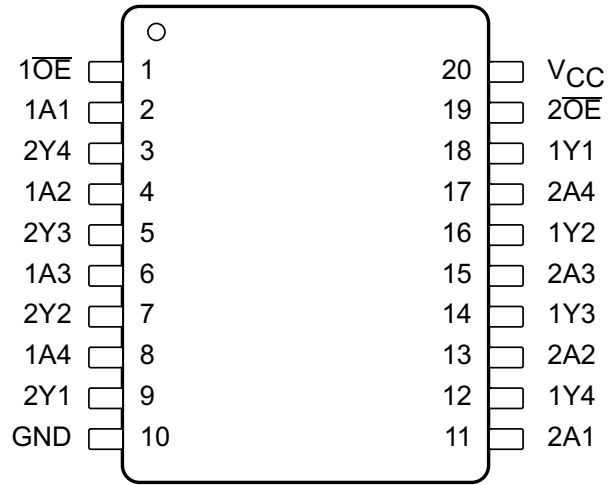

Not to scale

Figure 4-2. DB, DGV, DW, N, NS, DGS and PW Packages 20-Pin SSOP, TVSOP, SOIC, PDIP, SO, VSSOP and TSSOP Front View

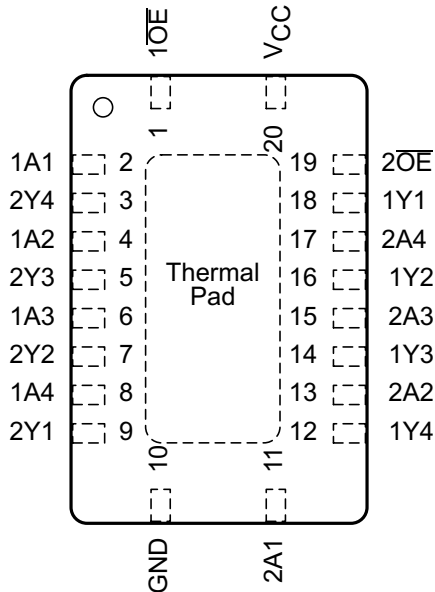

Not to scale

Figure 4-3. RGY and RKS Packages 20-Pin VQFN Top View

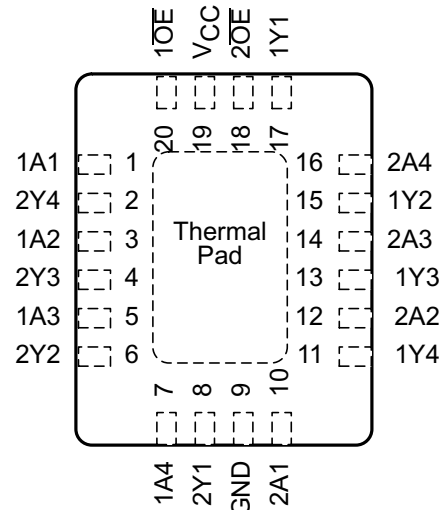

Not to scale

Figure 4-4. RWP Package 20-Pin X1QFN Top View

Table 4-1. Pin Functions

NAME	PIN			TYPE	DESCRIPTION
	DB, DGV, DW, N, NS, PW, RGY, DGS and RKS	ZQN	RWP		
1A1	2	A1	1	I	Port 1A1 input
1A2	4	B1	3	I	Port 1A2 input
1A3	6	C1	5	I	Port 1A3 input
1A4	8	D1	7	I	Port 1A4 input
1 \overline{OE}	1	A2	20	I	Output enable
1Y1	18	B4	17	O	Port 1Y1 output
1Y2	16	C4	15	O	Port 1Y2 output
1Y3	14	D4	13	O	Port 1Y3 output
1Y4	12	E4	11	O	Port 1Y4 output
2A1	11	E3	10	I	Port 2A1 input
2A2	13	D2	12	I	Port 2A2 input
2A3	15	C3	14	I	Port 2A3 input
2A4	17	B2	16	I	Port 2A4 input
2 \overline{OE}	19	A4	18	I	Output enable
2Y1	9	E2	8	O	Port 2Y1 output
2Y2	7	D3	6	O	Port 2Y2 output
2Y3	5	C2	4	O	Port 2Y3 output
2Y4	3	B3	2	O	Port 2Y4 output
GND	10	E1	9	—	Ground
V _{CC}	20	A3	19	—	Power pin

5 Specifications

5.1 Absolute Maximum Ratings

over operating free-air temperature range (unless otherwise noted)⁽¹⁾

		MIN	MAX	UNIT	
V _{CC}	Supply voltage	-0.5	6.5	V	
V _I	Input voltage ⁽²⁾	-0.5	6.5	V	
V _O	Voltage range applied to any output in the high-impedance or power-off state ⁽²⁾	-0.5	6.5	V	
V _O	Voltage range applied to any output in the high or low state ^{(2) (3)}	-0.5	V _{CC} + 0.5	V	
I _{IK}	Input clamp current	V _I < 0	-50	mA	
I _{OK}	Output clamp current	V _O < 0	-50	mA	
I _O	Continuous output current		±50	mA	
	Continuous current through V _{CC} or GND		±100	mA	
P _{tot}	Power dissipation	T _A = -40°C to +125°C ^{(4) (5)}	500	mW	
T _J	Junction temperature		150	°C	
T _{stg}	Storage temperature		-65	150	°C

- (1) Stresses beyond those listed under *Absolute Maximum Ratings* may cause permanent damage to the device. These are stress ratings only, and functional operation of the device at these or any other conditions beyond those indicated under [Section 5.3](#) is not implied. Exposure to absolute-maximum-rated conditions for extended periods may affect device reliability.
- (2) The input and output negative-voltage ratings may be exceeded if the input and output current ratings are observed.
- (3) The value of V_{CC} is provided in the [Section 5.3](#) table.
- (4) For the DW package: above 70°C the value of P_{tot} derates linearly with 8mW/K.
- (5) For the DB, DGV, N, NS, and PW packages: above 60°C the value of P_{tot} derates linearly with 5.5mW/K.

5.2 ESD Ratings

		VALUE	UNIT
V _(ESD)	Electrostatic discharge		
	Human-body model (HBM), per ANSI/ESDA/JEDEC JS-001 ⁽¹⁾	±2000	V
Charged-device model (CDM), per JEDEC specification JESD22C101 ⁽²⁾	±1000		

- (1) JEDEC document JEP155 states that 500V HBM allows safe manufacturing with a standard ESD control process.
- (2) JEDEC document JEP157 states that 250V CDM allows safe manufacturing with a standard ESD control process.

5.3 Recommended Operating Conditions

over recommended operating free-air temperature range (unless otherwise noted)⁽¹⁾

		T _A = 25°C		–40 TO +85°C		–40 TO +125°C		UNIT
		MIN	MAX	MIN	MAX	MIN	MAX	
V _{CC}	Supply voltage	Operating		1.65	3.6	1.65	3.6	V
		Data retention only		1.5		1.5		
V _{IH}	High-level input voltage	V _{CC} = 1.65V to 1.95V		0.65 × V _{CC}		0.65 × V _{CC}		V
		V _{CC} = 2.3V to 2.7V		1.7		1.7		
		V _{CC} = 2.7V to 3.6V		2		2		
V _{IL}	Low-level input voltage	V _{CC} = 1.65V to 1.95V		0.35 × V _{CC}		0.35 × V _{CC}		V
		V _{CC} = 2.3V to 2.7V		0.7		0.7		
		V _{CC} = 2.7V to 3.6V		0.8		0.8		
V _I	Input voltage	0	5.5	0	5.5	0	5.5	V
V _O	Output voltage	0	V _{CC}	0	V _{CC}	0	V _{CC}	V
I _{OH}	High-level output current	V _{CC} = 1.65V		–4		–4		mA
		V _{CC} = 2.3V		–8		–8		
		V _{CC} = 2.7V		–12		–12		
		V _{CC} = 3V		–24		–24		
I _{OL}	Low-level output current	V _{CC} = 1.65V		4		4		mA
		V _{CC} = 2.3V		8		8		
		V _{CC} = 2.7V		12		12		
		V _{CC} = 3V		24		24		
T _A	Ambient temperature	BGA package		–40		85		°C
		All other packages				–40 125		

(1) All unused inputs of the device must be held at V_{CC} or GND to ensure proper device operation. See [Implications of Slow or Floating CMOS Inputs](#), SCBA004.

5.4 Thermal Information

THERMAL METRIC ⁽¹⁾		SN74LVC244A											UNIT
		DB ⁽²⁾ (SSOP)	DGV ⁽²⁾ (TVSOP)	DW ⁽²⁾ (SOIC)	ZQN ⁽²⁾ (BGA)	N ⁽²⁾ (PDIP)	NS ⁽²⁾ (SO)	PW ⁽²⁾ (TSSOP)	RGY ⁽³⁾ (VQFN)	RWP ⁽³⁾ (X1QFN)	RKS ⁽³⁾ (VQFN)	DGS ⁽³⁾ (VSSOP)	
		20 PINS											
R _{θJA}	Junction-to-ambient thermal resistance	108.1	128.7	90.9	198.7	61.6	90.1	114.7	50.3	79.9	87.2	124.5	°C/W
R _{θJC(top)}	Junction-to-case (top) thermal resistance	70.2	43.7	55.3	106.8	46.5	56.4	48.4	58.4	63.2	93.4	62.9	°C/W
R _{θJB}	Junction-to-board thermal resistance	63.3	70.2	58.8	143.1	42.5	57.7	65.6	28.3	46.4	59.8	79.2	°C/W
ψ _{JT}	Junction-to-top characterization parameter	30.6	3.1	29.1	24.1	34.6	28.4	6.8	4.9	2.6	24.9	7.8	°C/W
ψ _{JB}	Junction-to-board characterization parameter	62.9	69.5	58.3	119.6	42.4	57.2	65.1	28.4	46.3	59.6	78.7	°C/W
R _{θJC(bot)}	Junction-to-case (bottom) thermal resistance	—	—	—	n/a	—	—	—	22.7	27.3	44.3	—	°C/W

(1) For more information about traditional and new thermal metrics, see the [Semiconductor and IC Package Thermal Metrics](#) application report.

(2) The package thermal impedance is calculated in accordance with JESD 51-7.

(3) The package thermal impedance is calculated in accordance with JESD 51-5.

5.5 Electrical Characteristics

over recommended operating free-air temperature range (unless otherwise noted)

PARAMETER	TEST CONDITIONS	V _{CC}	T _A = 25°C			–40 TO +85°C		–40 TO +125°C		UNIT
			MIN	TYP	MAX	MIN	MAX	MIN	MAX	
V _{OH}	I _{OH} = –100µA	1.65V to 3.6V	V _{CC} – 0.2			V _{CC} – 0.2		V _{CC} – 0.3		V
	I _{OH} = –4mA	1.65V	1.29			1.2		1.05		
	I _{OH} = –8mA	2.3V	1.9			1.7		1.55		
	I _{OH} = –12mA	2.7V	2.2			2.2		2.05		
		3V	2.4			2.4		2.25		
I _{OH} = –24mA	3V	2.3			2.2		2			
V _{OL}	I _{OL} = 100µA	1.65V to 3.6V	0.1			0.2		0.3		V
	I _{OL} = 4mA	1.65V	0.24			0.45		0.6		
	I _{OL} = 8mA	2.3V	0.3			0.7		0.75		
	I _{OL} = 12mA	2.7V	0.4			0.4		0.6		
	I _{OL} = 24mA	3V	0.55			0.55		0.8		
I _I	V _I = 5.5V or GND	3.6V	±1			±5		±20		µA
I _{off}	V _I or V _O = 5.5V	0	±1			±10		±20		µA
I _{OZ}	V _O = 0 to 5.5V	3.6V	±1			±10		±20		µA
I _{CC}	V _I = V _{CC} or GND	3.6V	1			10		40		µA
	3.6V ≤ V _I ≤ 5.5V ⁽¹⁾		1			10		40		
ΔI _{CC}	One input at V _{CC} – 0.6V, Other inputs at V _{CC} or GND	2.7V to 3.6V	500			500		5000		µA
C _i	V _I = V _{CC} or GND	3.3V	4							pF
C _o	V _O = V _{CC} or GND	3.3V	5.5							pF

(1) This applies in the disabled state only.

5.6 Switching Characteristics

over recommended operating free-air temperature range (unless otherwise noted) (see [Figure 6-1](#))

PARAMETER	FROM (INPUT)	TO (OUTPUT)	V _{CC}	T _A = 25°C			–40 TO +85°C		–40 TO +125°C		UNIT
				MIN	TYP	MAX	MIN	MAX	MIN	MAX	
t _{pd}	A	Y	1.5V		7	14.4		14.9		16.4	ns
			1.8V ± 0.15V		5.9	10.4		10.9		12.4	
			2.5V ± 0.2V		4.2	7.4		7.9		10	
			2.7V		4.2	6.7		6.9		8.2	
			3.3V ± 0.3V		3.9	5.7		5.9		7.2	
t _{en}	$\overline{\text{OE}}$	Y	1.5V		8.3	17.8		18.3		19.8	ns
			1.8V ± 0.15V		6.4	12.1		12.6		14.1	
			2.5V ± 0.2V		4.6	9.1		9.6		11.7	
			2.7V		5	8.4		8.6		10.3	
			3.3V ± 0.3V		4.5	7.4		7.6		9.4	
t _{dis}	$\overline{\text{OE}}$	Y	1.5V		7.2	15.6		16.1		17.6	ns
			1.8V ± 0.15V		5.8	11.6		12.1		13.6	
			2.5V ± 0.2V		3.7	7.3		7.8		9.9	
			2.7V		3.8	6.6		6.8		8.6	
			3.3V ± 0.3V		3.8	6.3		6.5		8	
t _{sk(o)}			3.3V ± 0.3V				1		1.5	ns	

5.7 Operating Characteristics

T_A = 25°C

PARAMETER		TEST CONDITIONS	V _{CC}	TYP	UNIT	
C _{pd}	Power dissipation capacitance per buffer/driver	Outputs enabled	f = 10MHz	1.8V	43	pF
				2.5V	43	
				3.3V	44	
		Outputs disabled	f = 10MHz	1.8V	1	
				2.5V	1	
				3.3V	2	

5.8 Typical Characteristics

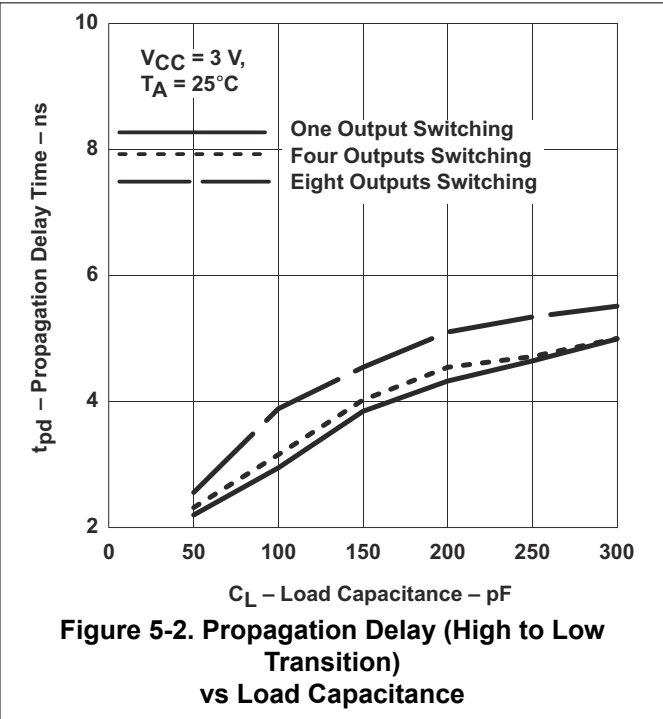
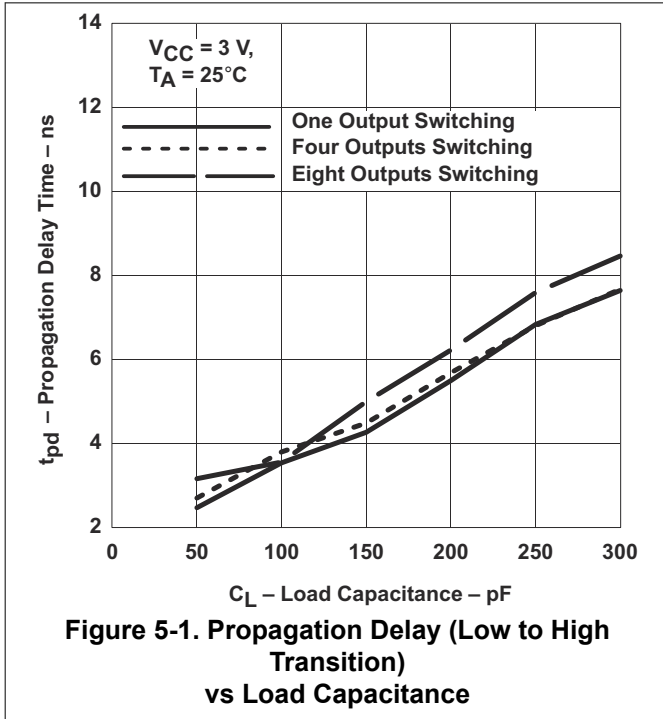

6 Parameter Measurement Information

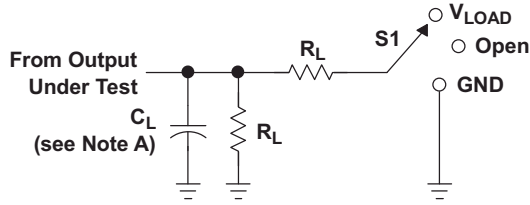

LOAD CIRCUIT

TEST	S1
t_{PLH}/t_{PHL}	Open
t_{PLZ}/t_{PZL}	V_{LOAD}
t_{PHZ}/t_{PZH}	GND

V_{CC}	INPUTS		V_M	V_{LOAD}	C_L	R_L	V_{Δ}
	V_I	t_r/t_f					
1.5 V	V_{CC}	≤ 2 ns	$V_{CC}/2$	$2 \times V_{CC}$	15 pF	2 k Ω	0.1 V
$1.8 V \pm 0.15 V$	V_{CC}	≤ 2 ns	$V_{CC}/2$	$2 \times V_{CC}$	30 pF	1 k Ω	0.15 V
$2.5 V \pm 0.2 V$	V_{CC}	≤ 2 ns	$V_{CC}/2$	$2 \times V_{CC}$	30 pF	500 Ω	0.15 V
2.7 V	2.7 V	≤ 2.5 ns	1.5 V	6 V	50 pF	500 Ω	0.3 V
$3.3 V \pm 0.3 V$	2.7 V	≤ 2.5 ns	1.5 V	6 V	50 pF	500 Ω	0.3 V

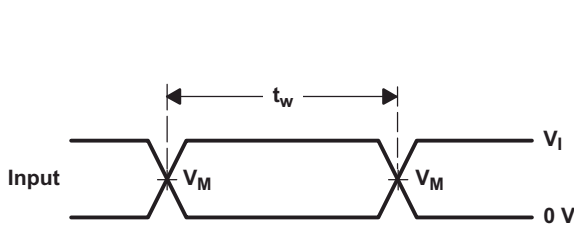

VOLTAGE WAVEFORMS
PULSE DURATION

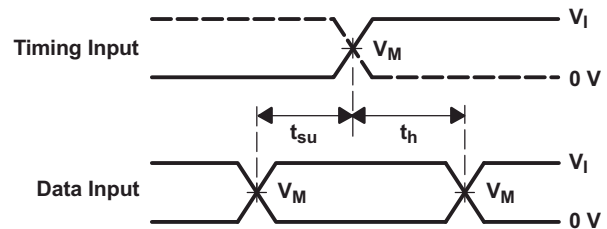

VOLTAGE WAVEFORMS
SETUP AND HOLD TIMES

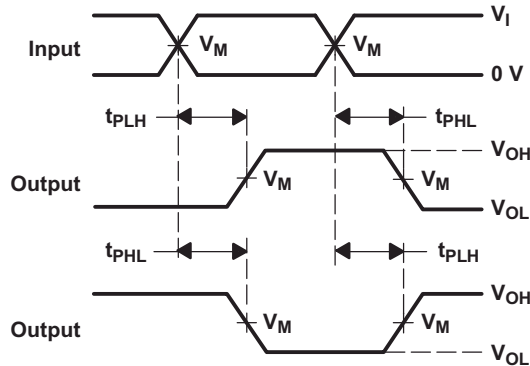

VOLTAGE WAVEFORMS
PROPAGATION DELAY TIMES
INVERTING AND NONINVERTING OUTPUTS

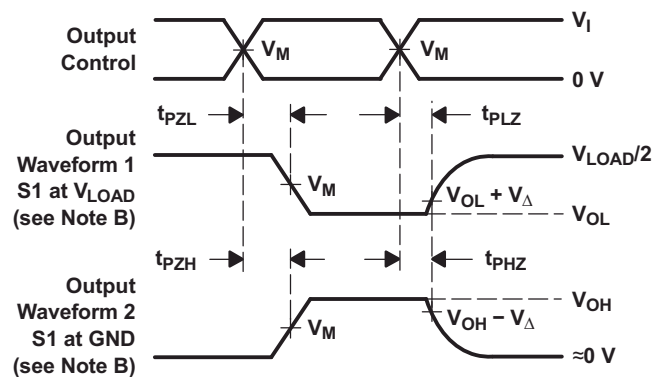

VOLTAGE WAVEFORMS
ENABLE AND DISABLE TIMES
LOW- AND HIGH-LEVEL ENABLING

- NOTES:
- A. C_L includes probe and jig capacitance.
 - B. Waveform 1 is for an output with internal conditions such that the output is low, except when disabled by the output control. Waveform 2 is for an output with internal conditions such that the output is high, except when disabled by the output control.
 - C. All input pulses are supplied by generators having the following characteristics: PRR ≤ 10 MHz, $Z_O = 50 \Omega$.
 - D. The outputs are measured one at a time, with one transition per measurement.
 - E. t_{PLZ} and t_{PHZ} are the same as t_{dis} .
 - F. t_{PZL} and t_{PZH} are the same as t_{en} .
 - G. t_{PLH} and t_{PHL} are the same as t_{pd} .
 - H. All parameters and waveforms are not applicable to all devices.

Figure 6-1. Load Circuit and Voltage Waveforms

7 Detailed Description

7.1 Overview

The SN74LVC244A contains 8 individual high speed CMOS buffers organized as two 4-bit buffers/line drives with 3-state outputs.

Each buffer performs the boolean logic function $xY_n = xA_n$, with x being the bank number and n being the channel number.

Each output enable ($x\overline{OE}$) controls four buffers. When the $x\overline{OE}$ pin is in the low state, the outputs of all buffers in the bank x are enabled. When the $x\overline{OE}$ pin is in the high state, the outputs of all buffers in the bank x are disabled. All disabled output are placed into the high-impedance state.

To put the device in the high-impedance state during power up or power down, tie both \overline{OE} pins to V_{CC} through a pull-up resistor; the minimum value of the resistor is determined by the current sinking capability of the driver and the leakage of the pin as defined in the *Electrical Characteristics* table.

7.2 Functional Block Diagram

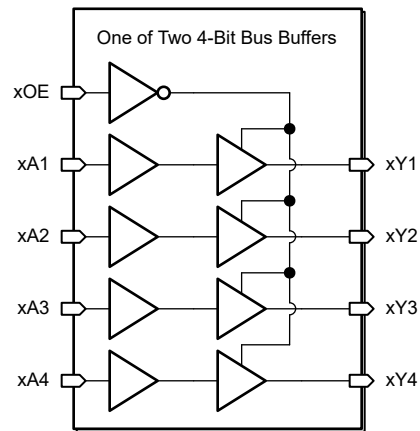

Figure 7-1. Logic Diagram (Positive Logic)

7.3 Feature Description

7.3.1 Balanced CMOS 3-State Outputs

This device includes balanced CMOS 3-state outputs. Driving high, driving low, and high impedance are the three states that these outputs can be in. The term *balanced* indicates that the device can sink and source similar currents. The drive capability of this device may create fast edges into light loads, so routing and load conditions should be considered to prevent ringing. Additionally, the outputs of this device can drive larger currents than the device can sustain without being damaged. It is important for the output power of the device to be limited to avoid damage due to overcurrent. The electrical and thermal limits defined in the *Absolute Maximum Ratings* must be followed at all times.

When placed into the high-impedance state, the output will neither source nor sink current, with the exception of minor leakage current as defined in the *Electrical Characteristics* table. In the high-impedance state, the output voltage is not controlled by the device and is dependent on external factors. If no other drivers are connected to the node, then this is known as a floating node and the voltage is unknown. A pull-up or pull-down resistor can be connected to the output to provide a known voltage at the output while it is in the high-impedance state. The value of the resistor will depend on multiple factors, including parasitic capacitance and power consumption limitations. Typically, a 10k Ω resistor can be used to meet these requirements.

Unused 3-state CMOS outputs should be left disconnected.

7.3.2 Standard CMOS Inputs

This device includes standard CMOS inputs. Standard CMOS inputs are high impedance and are typically modeled as a resistor in parallel with the input capacitance given in the *Electrical Characteristics*. The worst case resistance is calculated with the maximum input voltage, given in the *Absolute Maximum Ratings*, and the maximum input leakage current, given in the *Electrical Characteristics*, using Ohm's law ($R = V \div I$).

Standard CMOS inputs require that input signals transition between valid logic states quickly, as defined by the input transition time or rate in the *Recommended Operating Conditions* table. Failing to meet this specification will result in excessive power consumption and could cause oscillations. More details can be found in *Implications of Slow or Floating CMOS Inputs*.

Do not leave standard CMOS inputs floating at any time during operation. Unused inputs must be terminated at V_{CC} or GND. If a system will not be actively driving an input at all times, then a pull-up or pull-down resistor can be added to provide a valid input voltage during these times. The resistor value will depend on multiple factors; a 10k Ω resistor, however, is recommended and will typically meet all requirements.

7.3.3 Clamp Diode Structure

Figure 7-2 shows the inputs and outputs to this device have negative clamping diodes only.

CAUTION

Voltages beyond the values specified in the *Absolute Maximum Ratings* table can cause damage to the device. The input and output voltage ratings may be exceeded if the input and output clamp-current ratings are observed.

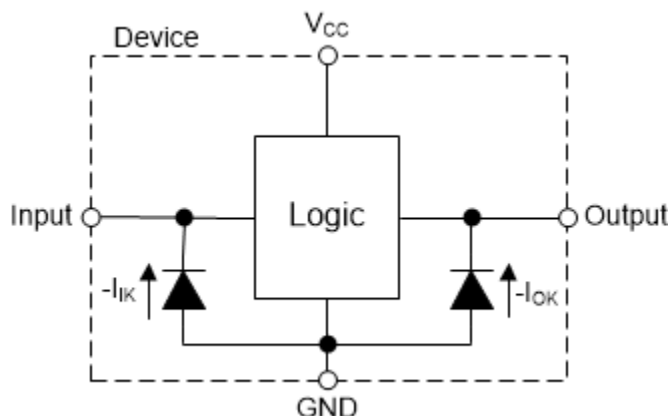

Figure 7-2. Electrical Placement of Clamping Diodes for Each Input and Output

7.4 Device Functional Modes

Table 7-1 lists the functional modes of the SN74LVC244A.

Table 7-1. Function Table

INPUTS ⁽¹⁾		OUTPUTS
\overline{OE}	A	Y
L	L	L
L	H	H
H	X	Z

(1) H = High Voltage Level, L = Low Voltage Level, X = Do Not Care, Z = High-Impedance State

8 Application and Implementation

Note

Information in the following applications sections is not part of the TI component specification, and TI does not warrant its accuracy or completeness. TI's customers are responsible for determining suitability of components for their purposes, as well as validating and testing their design implementation to confirm system functionality.

8.1 Application Information

SN74LVC244A is a high drive CMOS device that can be used for a multitude of bus interface type applications where output drive or PCB trace length is a concern.

8.2 Typical Application

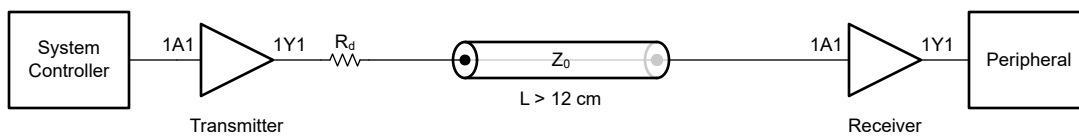

Figure 8-1. Application Schematic

8.2.1 Design Requirements

This device uses CMOS technology and has balanced output drive. Avoid bus contention because it can drive currents in excess of maximum limits. The high drive will also create fast edges into light loads, so consider routing and load conditions to prevent ringing.

8.2.2 Detailed Design Procedure

- Recommended Input Conditions:
 - For rise time and fall time specification, see $(\Delta t/\Delta V)$ in the *Recommended Operating Conditions* table.
 - For specified high and low levels, see $(V_{IH}$ and $V_{IL})$ in the *Recommended Operating Conditions* table.
 - Inputs are overvoltage tolerant allowing them to go as high as $(V_I \text{ max})$ in the *Recommended Operating Conditions* table at any valid V_{CC} .
- Recommended maximum Output Conditions:
 - Load currents should not exceed $(I_O \text{ max})$ per output and should not exceed (Continuous current through V_{CC} or GND) total current for the part. These limits are located in the *Absolute Maximum Ratings* table.
 - Outputs should not be pulled above V_{CC} .

8.2.3 Application Curves

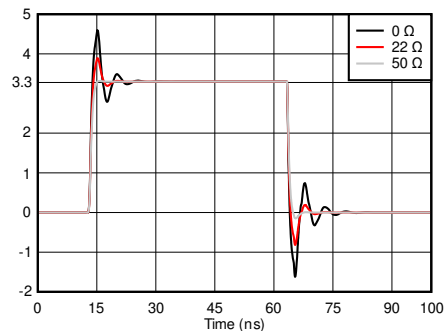

Figure 8-2. Simulated Signal Integrity at the Receiver With Different Damping Resistor (R_d) Values

8.3 Power Supply Recommendations

The power supply can be any voltage between the minimum and maximum supply voltage rating located in the *Recommended Operating Conditions*. Each V_{CC} terminal should have a good bypass capacitor to prevent power disturbance.

A $0.1\mu\text{F}$ capacitor is recommended for this device. It is acceptable to parallel multiple bypass capacitors to reject different frequencies of noise. The $0.1\mu\text{F}$ and $1\mu\text{F}$ capacitors are commonly used in parallel. The bypass capacitor should be installed as close to the power terminal as possible for best results.

8.4 Layout

8.4.1 Layout Guidelines

- Bypass capacitor placement
 - Place near the positive supply terminal of the device
 - Provide an electrically short ground return path
 - Use wide traces to minimize impedance
 - Keep the device, capacitors, and traces on the same side of the board whenever possible
- Signal trace geometry
 - 8mil to 12mil trace width
 - Lengths less than 12cm to minimize transmission line effects
 - Avoid 90° corners for signal traces
 - Use an unbroken ground plane below signal traces
 - Flood fill areas around signal traces with ground
 - Parallel traces must be separated by at least 3x dielectric thickness
 - For traces longer than 12cm
 - Use impedance controlled traces
 - Source-terminate using a series damping resistor near the output
 - Avoid branches; buffer each signal that must branch separately

8.4.2 Layout Example

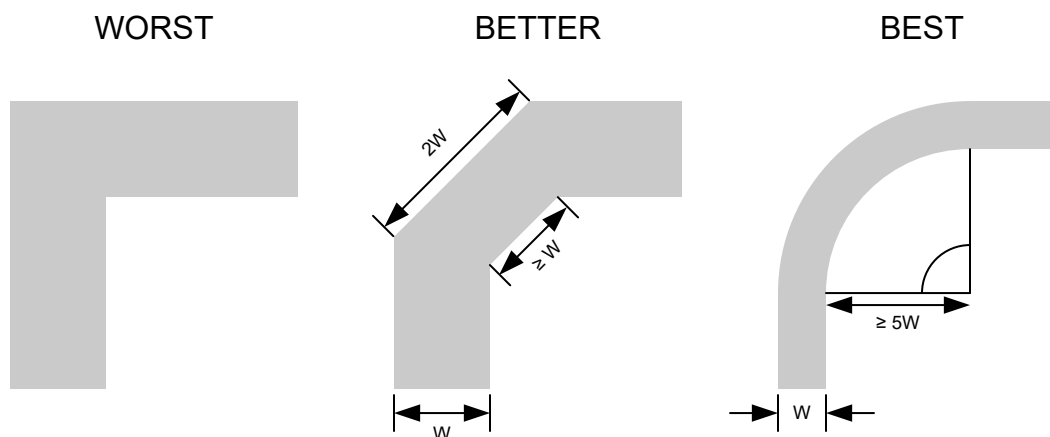

Figure 8-3. Example Trace Corners for Improved Signal Integrity

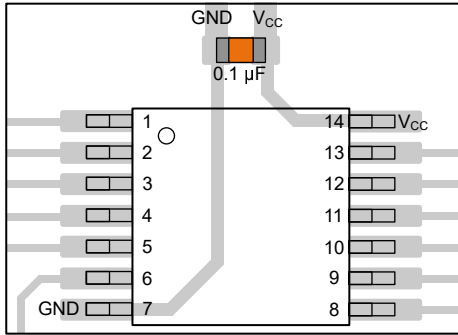

Figure 8-4. Example Bypass Capacitor Placement for TSSOP and Similar Packages

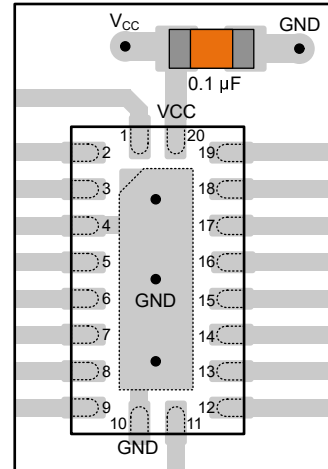

Figure 8-5. Example Bypass Capacitor Placement for WQFN and Similar Packages

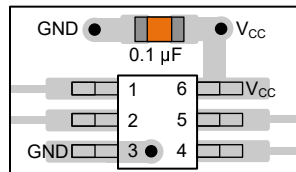

Figure 8-6. Example Bypass Capacitor Placement for SOT, SC70 and Similar Packages

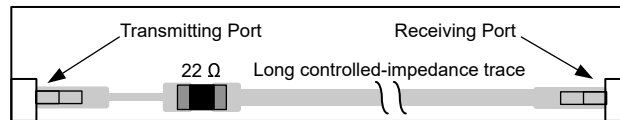

Figure 8-7. Example Damping Resistor Placement for Improved Signal Integrity

9 Device and Documentation Support

TI offers an extensive line of development tools. Tools and software to evaluate the performance of the device, generate code, and develop solutions are listed below.

9.1 Documentation Support

9.1.1 Related Documentation

For related documentation, see the following:

- Texas Instruments, [CMOS Power Consumption and \$C_{pd}\$ Calculation application note](#)
- Texas Instruments, [Designing With Logic application note](#)
- Texas Instruments, [Thermal Characteristics of Standard Linear and Logic \(SLL\) Packages and Devices application note](#)

9.2 Receiving Notification of Documentation Updates

To receive notification of documentation updates, navigate to the device product folder on ti.com. Click on *Notifications* to register and receive a weekly digest of any product information that has changed. For change details, review the revision history included in any revised document.

9.3 Support Resources

TI E2E™ [support forums](#) are an engineer's go-to source for fast, verified answers and design help — straight from the experts. Search existing answers or ask your own question to get the quick design help you need.

Linked content is provided "AS IS" by the respective contributors. They do not constitute TI specifications and do not necessarily reflect TI's views; see TI's [Terms of Use](#).

9.4 Trademarks

TI E2E™ is a trademark of Texas Instruments.

All trademarks are the property of their respective owners.

9.5 Electrostatic Discharge Caution



This integrated circuit can be damaged by ESD. Texas Instruments recommends that all integrated circuits be handled with appropriate precautions. Failure to observe proper handling and installation procedures can cause damage.

ESD damage can range from subtle performance degradation to complete device failure. Precision integrated circuits may be more susceptible to damage because very small parametric changes could cause the device not to meet its published specifications.

9.6 Glossary

[TI Glossary](#) This glossary lists and explains terms, acronyms, and definitions.

10 Revision History

NOTE: Page numbers for previous revisions may differ from page numbers in the current version.

Changes from Revision AE (August 2025) to Revision AF (February 2026) Page

- | | |
|---|---|
| • Added DGS (VSSOP, 20) package option..... | 1 |
|---|---|

Changes from Revision AD (March 2025) to Revision AE (August 2025) Page

- | | |
|---|---|
| • Removed Product Preview note for the RKS (VQFN, 20) package option..... | 1 |
|---|---|

Changes from Revision AC (October 2020) to Revision AD (March 2025)	Page
• Added RKS (VQFN, 20) package option.....	1

Changes from Revision AB (November 2016) to Revision AC (October 2020)	Page
• Updated the numbering format for tables, figures, and cross-references throughout the document.....	1

11 Mechanical, Packaging, and Orderable Information

The following pages include mechanical packaging and orderable information. This information is the most current data available for the designated devices. This data is subject to change without notice and revision of this document. For browser based versions of this data sheet, refer to the left hand navigation.

PACKAGING INFORMATION

Orderable part number	Status (1)	Material type (2)	Package Pins	Package qty Carrier	RoHS (3)	Lead finish/ Ball material (4)	MSL rating/ Peak reflow (5)	Op temp (°C)	Part marking (6)
PSN74LVC244ARKSR	Active	Preproduction	VQFN (RKS) 20	3000 LARGE T&R	-	Call TI	Call TI	-40 to 125	
PSN74LVC244ARKSR.A	Active	Preproduction	VQFN (RKS) 20	3000 LARGE T&R	-	Call TI	Call TI	-40 to 125	
SN74LVC244ADBR	Active	Production	SSOP (DB) 20	2000 LARGE T&R	Yes	NIPDAU	Level-1-260C-UNLIM	-40 to 125	LC244A
SN74LVC244ADBR.A	Active	Production	SSOP (DB) 20	2000 LARGE T&R	Yes	NIPDAU	Level-1-260C-UNLIM	-40 to 125	LC244A
SN74LVC244ADBR.B	Active	Production	SSOP (DB) 20	2000 LARGE T&R	Yes	NIPDAU	Level-1-260C-UNLIM	-40 to 125	LC244A
SN74LVC244ADBRE4	Active	Production	SSOP (DB) 20	2000 LARGE T&R	Yes	NIPDAU	Level-1-260C-UNLIM	-40 to 125	LC244A
SN74LVC244ADBRG4	Active	Production	SSOP (DB) 20	2000 LARGE T&R	Yes	NIPDAU	Level-1-260C-UNLIM	-40 to 125	LC244A
SN74LVC244ADGSR	Active	Production	VSSOP (DGS) 20	5000 LARGE T&R	Yes	NIPDAU	Level-1-260C-UNLIM	-40 to 125	C244A
SN74LVC244ADGVR	Active	Production	TVSOP (DGV) 20	2000 LARGE T&R	Yes	NIPDAU	Level-1-260C-UNLIM	-40 to 125	LC244A
SN74LVC244ADGVR.B	Active	Production	TVSOP (DGV) 20	2000 LARGE T&R	Yes	NIPDAU	Level-1-260C-UNLIM	-40 to 125	LC244A
SN74LVC244ADGVRG4	Active	Production	TVSOP (DGV) 20	2000 LARGE T&R	Yes	NIPDAU	Level-1-260C-UNLIM	-40 to 125	LC244A
SN74LVC244ADGVRG4.B	Active	Production	TVSOP (DGV) 20	2000 LARGE T&R	Yes	NIPDAU	Level-1-260C-UNLIM	-40 to 125	LC244A
SN74LVC244ADW	Active	Production	SOIC (DW) 20	25 TUBE	Yes	NIPDAU	Level-1-260C-UNLIM	-40 to 125	LVC244A
SN74LVC244ADW.B	Active	Production	SOIC (DW) 20	25 TUBE	Yes	NIPDAU	Level-1-260C-UNLIM	-40 to 125	LVC244A
SN74LVC244ADWE4	Active	Production	SOIC (DW) 20	25 TUBE	Yes	NIPDAU	Level-1-260C-UNLIM	-40 to 125	LVC244A
SN74LVC244ADWG4	Active	Production	SOIC (DW) 20	25 TUBE	Yes	NIPDAU	Level-1-260C-UNLIM	-40 to 125	LVC244A
SN74LVC244ADWR	Active	Production	SOIC (DW) 20	2000 LARGE T&R	Yes	NIPDAU SN	Level-1-260C-UNLIM	-40 to 125	LVC244A
SN74LVC244ADWR.A	Active	Production	SOIC (DW) 20	2000 LARGE T&R	Yes	NIPDAU	Level-1-260C-UNLIM	-40 to 125	LVC244A
SN74LVC244ADWR.B	Active	Production	SOIC (DW) 20	2000 LARGE T&R	Yes	NIPDAU	Level-1-260C-UNLIM	-40 to 125	LVC244A
SN74LVC244ADWRG4	Active	Production	SOIC (DW) 20	2000 LARGE T&R	Yes	NIPDAU	Level-1-260C-UNLIM	-40 to 125	LVC244A
SN74LVC244ADWRG4.A	Active	Production	SOIC (DW) 20	2000 LARGE T&R	Yes	NIPDAU	Level-1-260C-UNLIM	-40 to 125	LVC244A
SN74LVC244ADWRG4.B	Active	Production	SOIC (DW) 20	2000 LARGE T&R	Yes	NIPDAU	Level-1-260C-UNLIM	-40 to 125	LVC244A
SN74LVC244AN	Active	Production	PDIP (N) 20	20 TUBE	Yes	NIPDAU	N/A for Pkg Type	-40 to 125	SN74LVC244AN
SN74LVC244AN.B	Active	Production	PDIP (N) 20	20 TUBE	Yes	NIPDAU	N/A for Pkg Type	-40 to 125	SN74LVC244AN
SN74LVC244ANSR	Active	Production	SOP (NS) 20	2000 LARGE T&R	Yes	NIPDAU	Level-1-260C-UNLIM	-40 to 125	LVC244A
SN74LVC244ANSR.A	Active	Production	SOP (NS) 20	2000 LARGE T&R	Yes	NIPDAU	Level-1-260C-UNLIM	-40 to 125	LVC244A
SN74LVC244ANSR.B	Active	Production	SOP (NS) 20	2000 LARGE T&R	Yes	NIPDAU	Level-1-260C-UNLIM	-40 to 125	LVC244A
SN74LVC244ANSRG4	Active	Production	SOP (NS) 20	2000 LARGE T&R	Yes	NIPDAU	Level-1-260C-UNLIM	-40 to 125	LVC244A
SN74LVC244ANSRG4.A	Active	Production	SOP (NS) 20	2000 LARGE T&R	Yes	NIPDAU	Level-1-260C-UNLIM	-40 to 125	LVC244A

Orderable part number	Status (1)	Material type (2)	Package Pins	Package qty Carrier	RoHS (3)	Lead finish/ Ball material (4)	MSL rating/ Peak reflow (5)	Op temp (°C)	Part marking (6)
SN74LVC244ANSRG4.B	Active	Production	SOP (NS) 20	2000 LARGE T&R	Yes	NIPDAU	Level-1-260C-UNLIM	-40 to 125	LVC244A
SN74LVC244APW	Active	Production	TSSOP (PW) 20	70 TUBE	Yes	NIPDAU	Level-1-260C-UNLIM	-40 to 125	LC244A
SN74LVC244APW.B	Active	Production	TSSOP (PW) 20	70 TUBE	Yes	NIPDAU	Level-1-260C-UNLIM	-40 to 125	LC244A
SN74LVC244APWE4	Active	Production	TSSOP (PW) 20	70 TUBE	Yes	NIPDAU	Level-1-260C-UNLIM	-40 to 125	LC244A
SN74LVC244APWG4	Active	Production	TSSOP (PW) 20	70 TUBE	Yes	NIPDAU	Level-1-260C-UNLIM	-40 to 125	LC244A
SN74LVC244APWR	Active	Production	TSSOP (PW) 20	2000 LARGE T&R	Yes	NIPDAU SN	Level-1-260C-UNLIM	-40 to 125	LC244A
SN74LVC244APWR.A	Active	Production	TSSOP (PW) 20	2000 LARGE T&R	Yes	NIPDAU	Level-1-260C-UNLIM	-40 to 125	LC244A
SN74LVC244APWR.B	Active	Production	TSSOP (PW) 20	2000 LARGE T&R	Yes	NIPDAU	Level-1-260C-UNLIM	-40 to 125	LC244A
SN74LVC244APWRE4	Active	Production	TSSOP (PW) 20	2000 LARGE T&R	Yes	NIPDAU	Level-1-260C-UNLIM	-40 to 125	LC244A
SN74LVC244APWRG3	Active	Production	TSSOP (PW) 20	2000 LARGE T&R	Yes	SN	Level-1-260C-UNLIM	-40 to 125	LC244A
SN74LVC244APWRG3.A	Active	Production	TSSOP (PW) 20	2000 LARGE T&R	Yes	SN	Level-1-260C-UNLIM	-40 to 125	LC244A
SN74LVC244APWRG3.B	Active	Production	TSSOP (PW) 20	2000 LARGE T&R	Yes	SN	Level-1-260C-UNLIM	-40 to 125	LC244A
SN74LVC244APWRG4	Active	Production	TSSOP (PW) 20	2000 LARGE T&R	Yes	NIPDAU	Level-1-260C-UNLIM	-40 to 125	LC244A
SN74LVC244APWRG4.A	Active	Production	TSSOP (PW) 20	2000 LARGE T&R	Yes	NIPDAU	Level-1-260C-UNLIM	-40 to 125	LC244A
SN74LVC244APWRG4.B	Active	Production	TSSOP (PW) 20	2000 LARGE T&R	Yes	NIPDAU	Level-1-260C-UNLIM	-40 to 125	LC244A
SN74LVC244APWT	Active	Production	TSSOP (PW) 20	250 SMALL T&R	Yes	NIPDAU	Level-1-260C-UNLIM	-40 to 125	LC244A
SN74LVC244APWT.B	Active	Production	TSSOP (PW) 20	250 SMALL T&R	Yes	NIPDAU	Level-1-260C-UNLIM	-40 to 125	LC244A
SN74LVC244APWTE4	Active	Production	TSSOP (PW) 20	250 SMALL T&R	Yes	NIPDAU	Level-1-260C-UNLIM	-40 to 125	LC244A
SN74LVC244APWTG4	Active	Production	TSSOP (PW) 20	250 SMALL T&R	Yes	NIPDAU	Level-1-260C-UNLIM	-40 to 125	LC244A
SN74LVC244ARGYR	Active	Production	VQFN (RGY) 20	3000 LARGE T&R	Yes	NIPDAU	Level-2-260C-1 YEAR	-40 to 125	LC244A
SN74LVC244ARGYR.A	Active	Production	VQFN (RGY) 20	3000 LARGE T&R	Yes	NIPDAU	Level-2-260C-1 YEAR	-40 to 125	LC244A
SN74LVC244ARGYR.B	Active	Production	VQFN (RGY) 20	3000 LARGE T&R	Yes	NIPDAU	Level-2-260C-1 YEAR	-40 to 125	LC244A
SN74LVC244ARGYRG4	Active	Production	VQFN (RGY) 20	3000 LARGE T&R	Yes	NIPDAU	Level-2-260C-1 YEAR	-40 to 125	LC244A
SN74LVC244ARKSR	Active	Production	VQFN (RKS) 20	3000 LARGE T&R	Yes	SN	Level-1-260C-UNLIM	-40 to 125	LC244A
SN74LVC244ARWPR	Active	Production	X1QFN (RWP) 20	2000 LARGE T&R	Yes	NIPDAU	Level-1-260C-UNLIM	-40 to 125	LC244A
SN74LVC244ARWPR.A	Active	Production	X1QFN (RWP) 20	2000 LARGE T&R	Yes	NIPDAU	Level-1-260C-UNLIM	-40 to 125	LC244A
SN74LVC244ARWPR.B	Active	Production	X1QFN (RWP) 20	2000 LARGE T&R	Yes	NIPDAU	Level-1-260C-UNLIM	-40 to 125	LC244A
SN74LVC244ARWPRG4.A	Active	Production	X1QFN (RWP) 20	2000 LARGE T&R	Yes	NIPDAU	Level-1-260C-UNLIM	-40 to 125	LC244A
SN74LVC244ARWPRG4.B	Active	Production	X1QFN (RWP) 20	2000 LARGE T&R	Yes	NIPDAU	Level-1-260C-UNLIM	-40 to 125	LC244A

(1) **Status:** For more details on status, see our [product life cycle](#).

- (2) **Material type:** When designated, preproduction parts are prototypes/experimental devices, and are not yet approved or released for full production. Testing and final process, including without limitation quality assurance, reliability performance testing, and/or process qualification, may not yet be complete, and this item is subject to further changes or possible discontinuation. If available for ordering, purchases will be subject to an additional waiver at checkout, and are intended for early internal evaluation purposes only. These items are sold without warranties of any kind.
- (3) **RoHS values:** Yes, No, RoHS Exempt. See the [TI RoHS Statement](#) for additional information and value definition.
- (4) **Lead finish/Ball material:** Parts may have multiple material finish options. Finish options are separated by a vertical ruled line. Lead finish/Ball material values may wrap to two lines if the finish value exceeds the maximum column width.
- (5) **MSL rating/Peak reflow:** The moisture sensitivity level ratings and peak solder (reflow) temperatures. In the event that a part has multiple moisture sensitivity ratings, only the lowest level per JEDEC standards is shown. Refer to the shipping label for the actual reflow temperature that will be used to mount the part to the printed circuit board.
- (6) **Part marking:** There may be an additional marking, which relates to the logo, the lot trace code information, or the environmental category of the part.

Multiple part markings will be inside parentheses. Only one part marking contained in parentheses and separated by a "~" will appear on a part. If a line is indented then it is a continuation of the previous line and the two combined represent the entire part marking for that device.

Important Information and Disclaimer: The information provided on this page represents TI's knowledge and belief as of the date that it is provided. TI bases its knowledge and belief on information provided by third parties, and makes no representation or warranty as to the accuracy of such information. Efforts are underway to better integrate information from third parties. TI has taken and continues to take reasonable steps to provide representative and accurate information but may not have conducted destructive testing or chemical analysis on incoming materials and chemicals. TI and TI suppliers consider certain information to be proprietary, and thus CAS numbers and other limited information may not be available for release.

In no event shall TI's liability arising out of such information exceed the total purchase price of the TI part(s) at issue in this document sold by TI to Customer on an annual basis.

OTHER QUALIFIED VERSIONS OF SN74LVC244A :

- Automotive : [SN74LVC244A-Q1](#)

NOTE: Qualified Version Definitions:

- Automotive - Q100 devices qualified for high-reliability automotive applications targeting zero defects

TAPE AND REEL INFORMATION

QUADRANT ASSIGNMENTS FOR PIN 1 ORIENTATION IN TAPE

*All dimensions are nominal

Device	Package Type	Package Drawing	Pins	SPQ	Reel Diameter (mm)	Reel Width W1 (mm)	A0 (mm)	B0 (mm)	K0 (mm)	P1 (mm)	W (mm)	Pin1 Quadrant
SN74LVC244ADBR	SSOP	DB	20	2000	330.0	16.4	8.2	7.5	2.5	12.0	16.0	Q1
SN74LVC244ADGSR	VSSOP	DGS	20	5000	330.0	16.4	5.4	5.4	1.45	8.0	16.0	Q1
SN74LVC244ADGVR	TVSOP	DGV	20	2000	330.0	12.4	6.9	5.6	1.6	8.0	12.0	Q1
SN74LVC244ADGVRG4	TVSOP	DGV	20	2000	330.0	12.4	6.9	5.6	1.6	8.0	12.0	Q1
SN74LVC244ADWR	SOIC	DW	20	2000	330.0	24.4	10.9	13.3	2.7	12.0	24.0	Q1
SN74LVC244ADWRG4	SOIC	DW	20	2000	330.0	24.4	10.8	13.3	2.7	12.0	24.0	Q1
SN74LVC244ANSR	SOP	NS	20	2000	330.0	24.4	8.4	13.0	2.5	12.0	24.0	Q1
SN74LVC244ANSRG4	SOP	NS	20	2000	330.0	24.4	8.4	13.0	2.5	12.0	24.0	Q1
SN74LVC244APWR	TSSOP	PW	20	2000	330.0	16.4	6.95	7.1	1.6	8.0	16.0	Q1
SN74LVC244APWR	TSSOP	PW	20	2000	330.0	16.4	6.95	7.0	1.4	8.0	16.0	Q1
SN74LVC244APWRG3	TSSOP	PW	20	2000	330.0	16.4	6.95	7.1	1.6	8.0	16.0	Q1
SN74LVC244APWRG4	TSSOP	PW	20	2000	330.0	16.4	6.95	7.0	1.4	8.0	16.0	Q1
SN74LVC244APWT	TSSOP	PW	20	250	330.0	16.4	6.95	7.0	1.4	8.0	16.0	Q1
SN74LVC244ARGYR	VQFN	RGY	20	3000	330.0	12.4	3.71	4.71	1.1	8.0	12.0	Q1
SN74LVC244ARKSR	VQFN	RKS	20	3000	180.0	12.4	2.8	4.8	1.2	4.0	12.0	Q1
SN74LVC244ARWPR	X1QFN	RWP	20	2000	178.0	13.5	2.85	3.65	0.75	8.0	12.0	Q1

TAPE AND REEL BOX DIMENSIONS

*All dimensions are nominal

Device	Package Type	Package Drawing	Pins	SPQ	Length (mm)	Width (mm)	Height (mm)
SN74LVC244ADBR	SSOP	DB	20	2000	353.0	353.0	32.0
SN74LVC244ADGSR	VSSOP	DGS	20	5000	353.0	353.0	32.0
SN74LVC244ADGVR	TVSOP	DGV	20	2000	353.0	353.0	32.0
SN74LVC244ADGVRG4	TVSOP	DGV	20	2000	353.0	353.0	32.0
SN74LVC244ADWR	SOIC	DW	20	2000	356.0	356.0	45.0
SN74LVC244ADWRG4	SOIC	DW	20	2000	356.0	356.0	45.0
SN74LVC244ANSR	SOP	NS	20	2000	356.0	356.0	45.0
SN74LVC244ANSRG4	SOP	NS	20	2000	356.0	356.0	45.0
SN74LVC244APWR	TSSOP	PW	20	2000	364.0	364.0	27.0
SN74LVC244APWR	TSSOP	PW	20	2000	353.0	353.0	32.0
SN74LVC244APWRG3	TSSOP	PW	20	2000	364.0	364.0	27.0
SN74LVC244APWRG4	TSSOP	PW	20	2000	353.0	353.0	32.0
SN74LVC244APWT	TSSOP	PW	20	250	353.0	353.0	32.0
SN74LVC244ARGYR	VQFN	RGY	20	3000	353.0	353.0	32.0
SN74LVC244ARKSR	VQFN	RKS	20	3000	210.0	185.0	35.0
SN74LVC244ARWPR	X1QFN	RWP	20	2000	189.0	185.0	36.0

TUBE

*All dimensions are nominal

Device	Package Name	Package Type	Pins	SPQ	L (mm)	W (mm)	T (μm)	B (mm)
SN74LVC244ADW	DW	SOIC	20	25	507	12.83	5080	6.6
SN74LVC244ADW.B	DW	SOIC	20	25	507	12.83	5080	6.6
SN74LVC244ADWE4	DW	SOIC	20	25	507	12.83	5080	6.6
SN74LVC244ADWG4	DW	SOIC	20	25	507	12.83	5080	6.6
SN74LVC244AN	N	PDIP	20	20	506	13.97	11230	4.32
SN74LVC244AN.B	N	PDIP	20	20	506	13.97	11230	4.32
SN74LVC244APW	PW	TSSOP	20	70	530	10.2	3600	3.5
SN74LVC244APW.B	PW	TSSOP	20	70	530	10.2	3600	3.5
SN74LVC244APWE4	PW	TSSOP	20	70	530	10.2	3600	3.5
SN74LVC244APWG4	PW	TSSOP	20	70	530	10.2	3600	3.5

GENERIC PACKAGE VIEW

RGY 20

VQFN - 1 mm max height

3.5 x 4.5, 0.5 mm pitch

PLASTIC QUAD FGLATPACK - NO LEAD

This image is a representation of the package family, actual package may vary.
Refer to the product data sheet for package details.

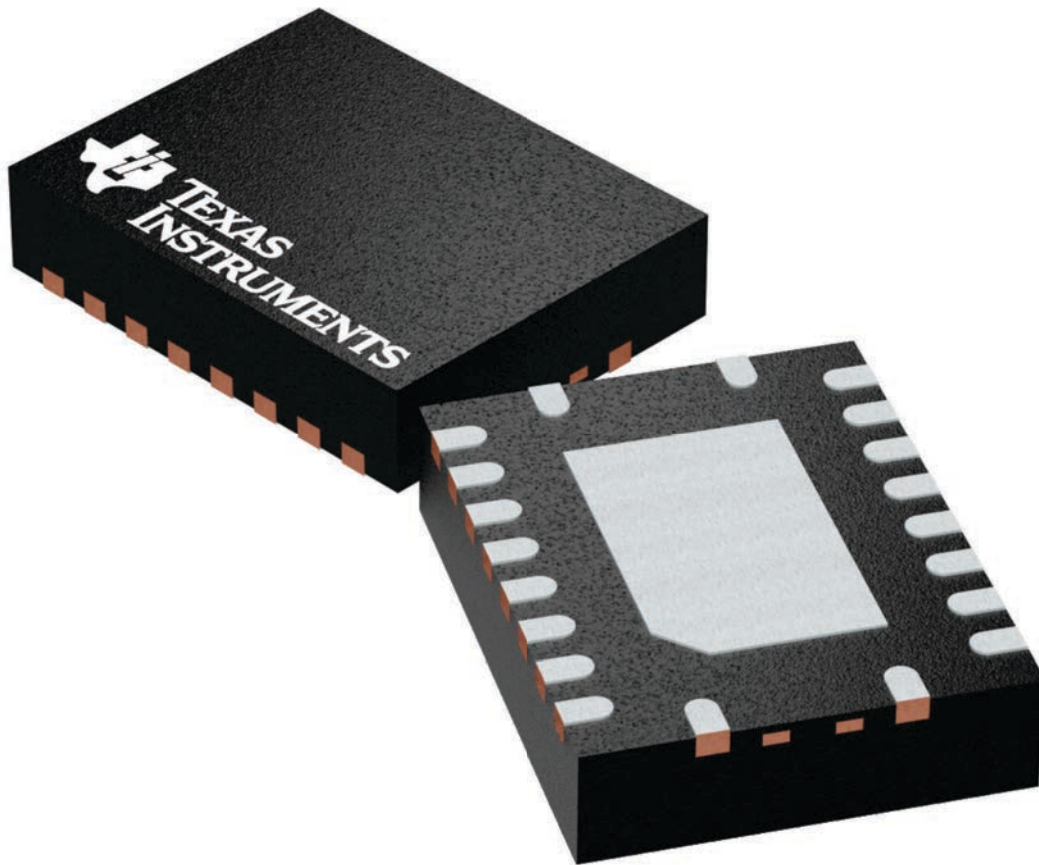

4225264/A

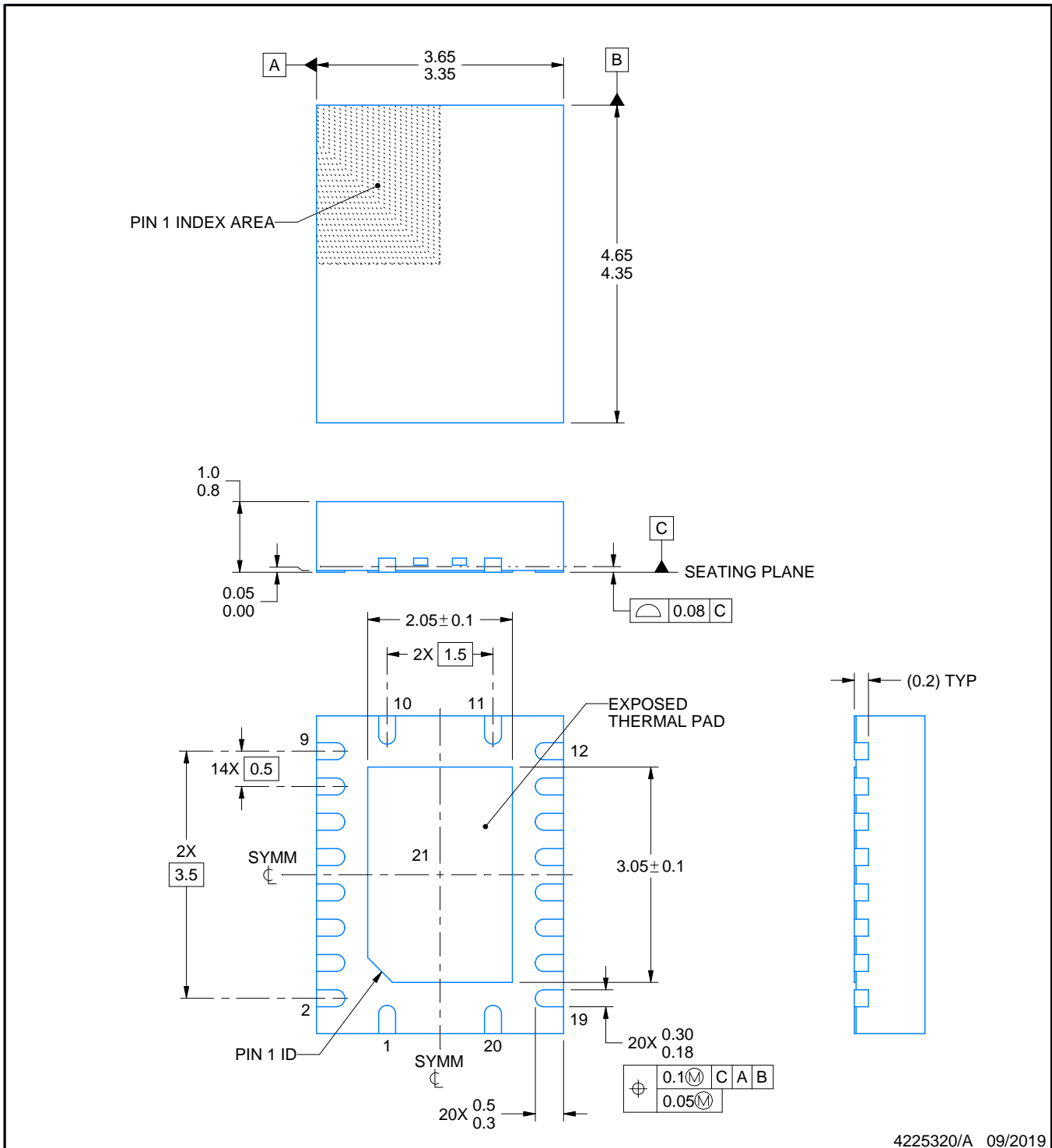
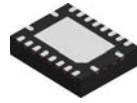

NOTES:

1. All linear dimensions are in millimeters. Any dimensions in parenthesis are for reference only. Dimensioning and tolerancing per ASME Y14.5M.
2. This drawing is subject to change without notice.
3. The package thermal pad must be soldered to the printed circuit board for thermal and mechanical performance.

EXAMPLE BOARD LAYOUT

RGY0020A

VQFN - 1 mm max height

PLASTIC QUAD FLATPACK - NO LEAD

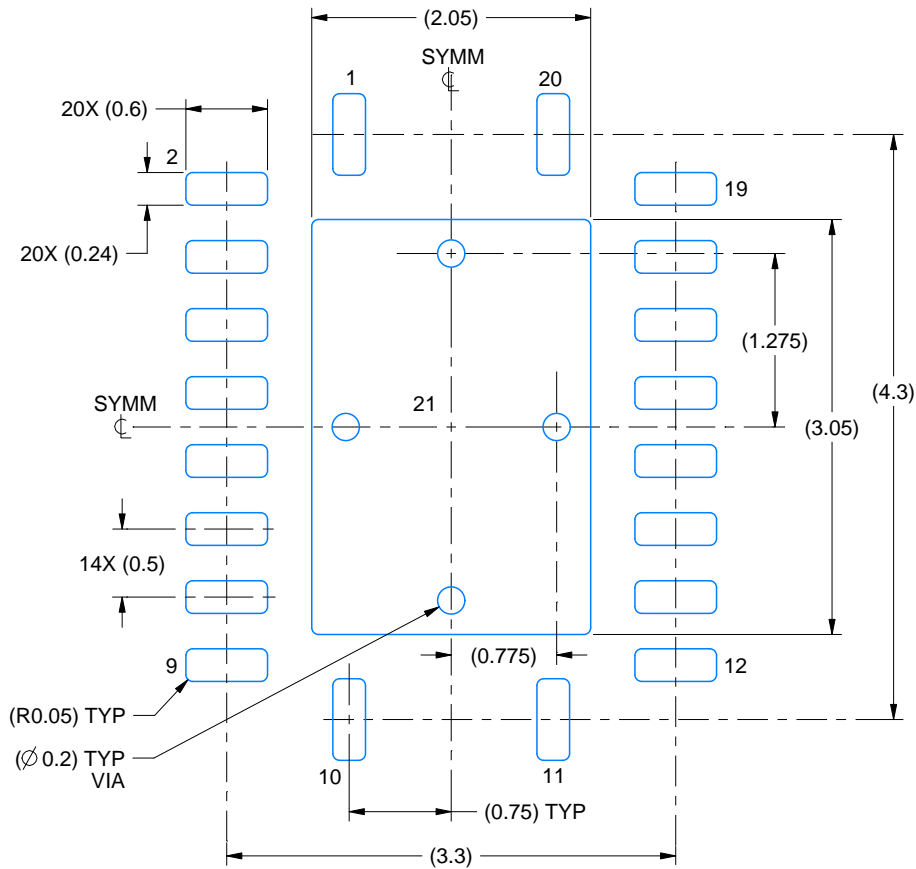

LAND PATTERN EXAMPLE
EXPOSED METAL SHOWN
SCALE:18X

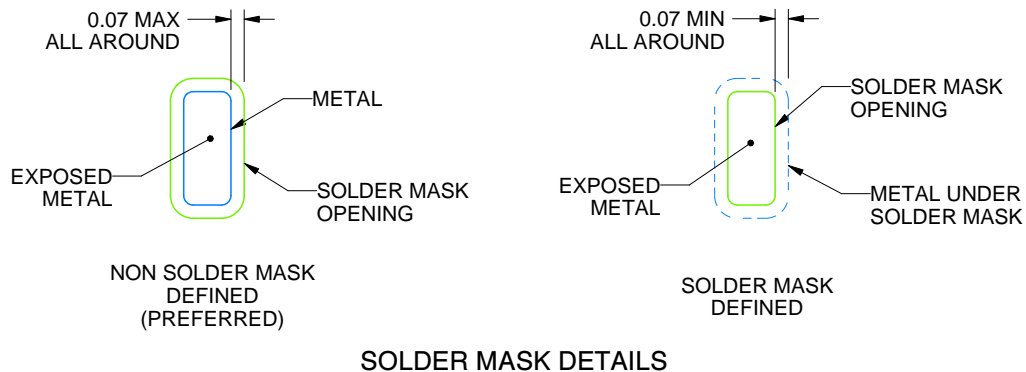

SOLDER MASK DETAILS

4225320/A 09/2019

NOTES: (continued)

4. This package is designed to be soldered to a thermal pad on the board. For more information, see Texas Instruments literature number SLUA271 (www.ti.com/lit/slua271).
5. Vias are optional depending on application, refer to device data sheet. If any vias are implemented, refer to their locations shown on this view. It is recommended that vias under paste be filled, plugged or tented.

EXAMPLE STENCIL DESIGN

RGY0020A

VQFN - 1 mm max height

PLASTIC QUAD FLATPACK - NO LEAD

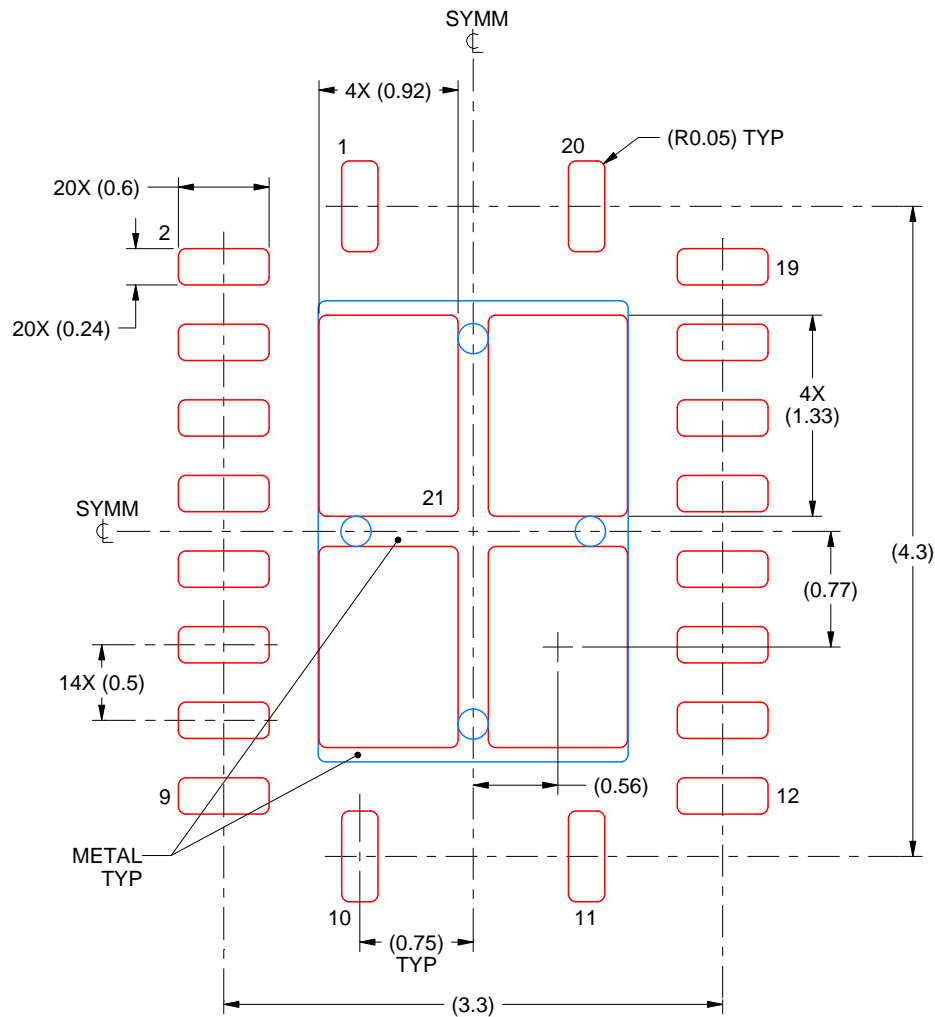

SOLDER PASTE EXAMPLE
BASED ON 0.125 mm THICK STENCIL

EXPOSED PAD 21
78% PRINTED SOLDER COVERAGE BY AREA UNDER PACKAGE
SCALE:20X

4225320/A 09/2019

NOTES: (continued)

6. Laser cutting apertures with trapezoidal walls and rounded corners may offer better paste release. IPC-7525 may have alternate design recommendations.

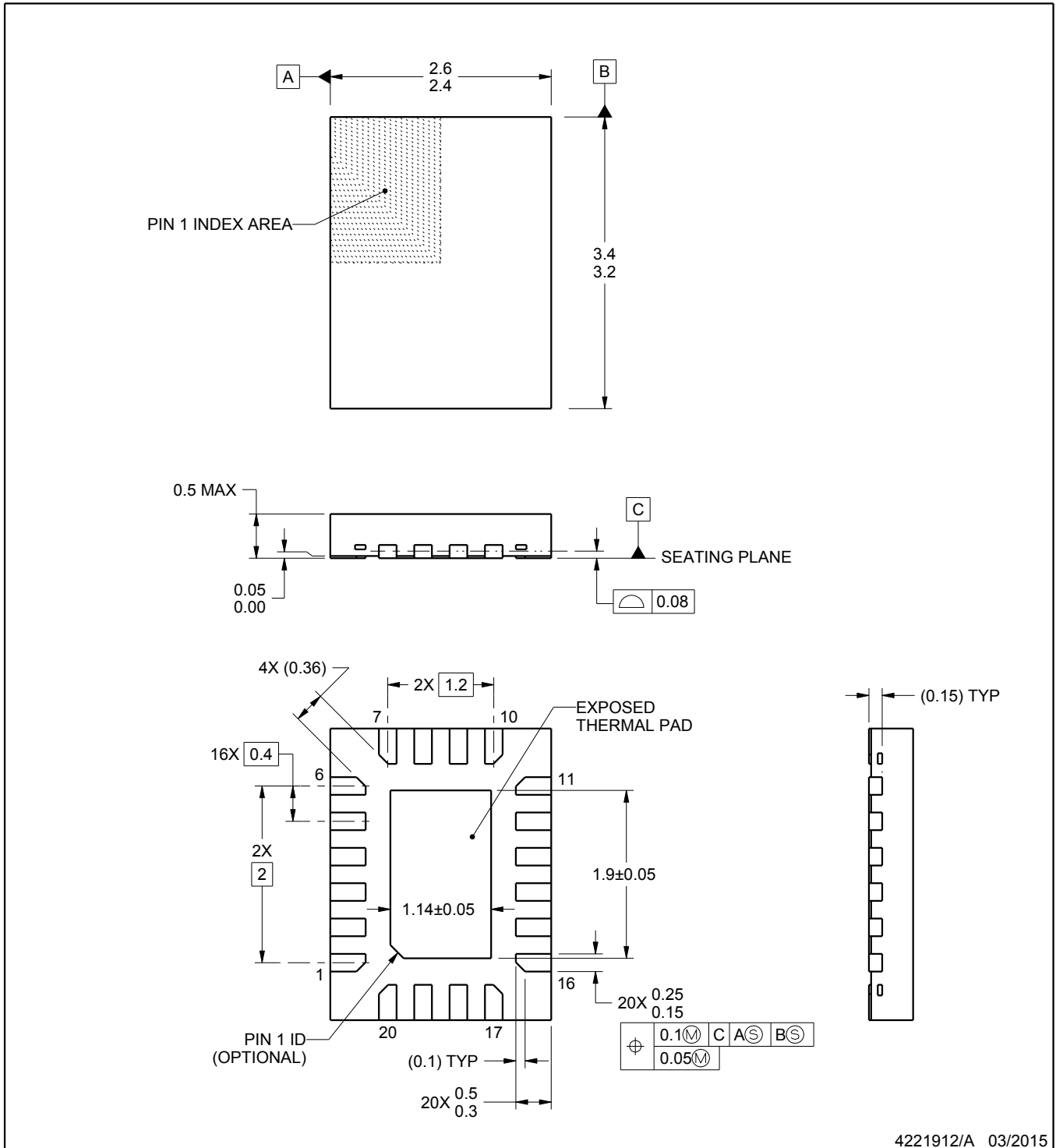
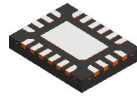

4221912/A 03/2015

NOTES:

1. All linear dimensions are in millimeters. Any dimensions in parenthesis are for reference only. Dimensioning and tolerancing per ASME Y14.5M.
2. This drawing is subject to change without notice.
3. The package thermal pad must be soldered to the printed circuit board for thermal and mechanical performance.

EXAMPLE STENCIL DESIGN

RWP0020A

X1QFN - 0.5 mm max height

PLASTIC QUAD FLATPACK - NO LEAD

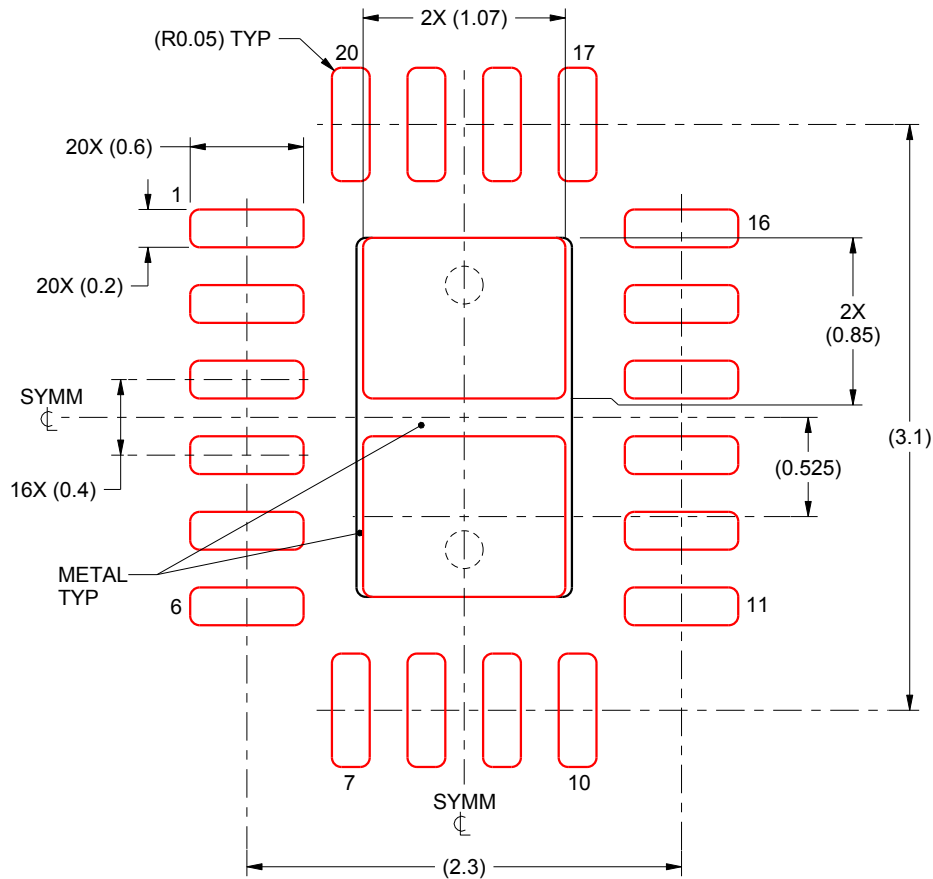

SOLDER PASTE EXAMPLE
BASED ON 0.1 mm THICK STENCIL

EXPOSED PAD
84% PRINTED SOLDER COVERAGE BY AREA
SCALE:25X

4221912/A 03/2015

NOTES: (continued)

5. Laser cutting apertures with trapezoidal walls and rounded corners may offer better paste release. IPC-7525 may have alternate design recommendations.

N (R-PDIP-T**)

PLASTIC DUAL-IN-LINE PACKAGE

16 PINS SHOWN



- NOTES:
- A. All linear dimensions are in inches (millimeters).
 - B. This drawing is subject to change without notice.
 - Falls within JEDEC MS-001, except 18 and 20 pin minimum body length (Dim A).
 - The 20 pin end lead shoulder width is a vendor option, either half or full width.

DW0020A



PACKAGE OUTLINE

SOIC - 2.65 mm max height

SOIC



4220724/A 05/2016

NOTES:

1. All linear dimensions are in millimeters. Dimensions in parenthesis are for reference only. Dimensioning and tolerancing per ASME Y14.5M.
2. This drawing is subject to change without notice.
3. This dimension does not include mold flash, protrusions, or gate burrs. Mold flash, protrusions, or gate burrs shall not exceed 0.15 mm per side.
4. This dimension does not include interlead flash. Interlead flash shall not exceed 0.43 mm per side.
5. Reference JEDEC registration MS-013.

EXAMPLE BOARD LAYOUT

DW0020A

SOIC - 2.65 mm max height

SOIC



LAND PATTERN EXAMPLE
SCALE:6X



SOLDER MASK DETAILS

4220724/A 05/2016

NOTES: (continued)

- 6. Publication IPC-7351 may have alternate designs.
- 7. Solder mask tolerances between and around signal pads can vary based on board fabrication site.

EXAMPLE STENCIL DESIGN

DW0020A

SOIC - 2.65 mm max height

SOIC



SOLDER PASTE EXAMPLE
BASED ON 0.125 mm THICK STENCIL
SCALE:6X

4220724/A 05/2016

NOTES: (continued)

8. Laser cutting apertures with trapezoidal walls and rounded corners may offer better paste release. IPC-7525 may have alternate design recommendations.
9. Board assembly site may have different recommendations for stencil design.

EXAMPLE BOARD LAYOUT

PW0020A

TSSOP - 1.2 mm max height

SMALL OUTLINE PACKAGE

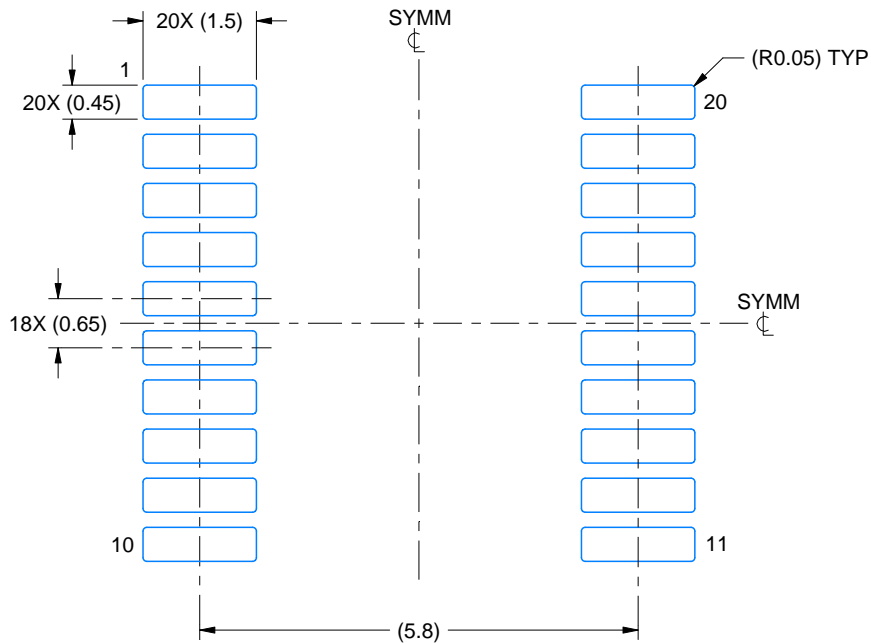

LAND PATTERN EXAMPLE
EXPOSED METAL SHOWN
SCALE: 10X



SOLDER MASK DETAILS

4220206/A 02/2017

NOTES: (continued)

- 6. Publication IPC-7351 may have alternate designs.
- 7. Solder mask tolerances between and around signal pads can vary based on board fabrication site.

EXAMPLE STENCIL DESIGN

PW0020A

TSSOP - 1.2 mm max height

SMALL OUTLINE PACKAGE

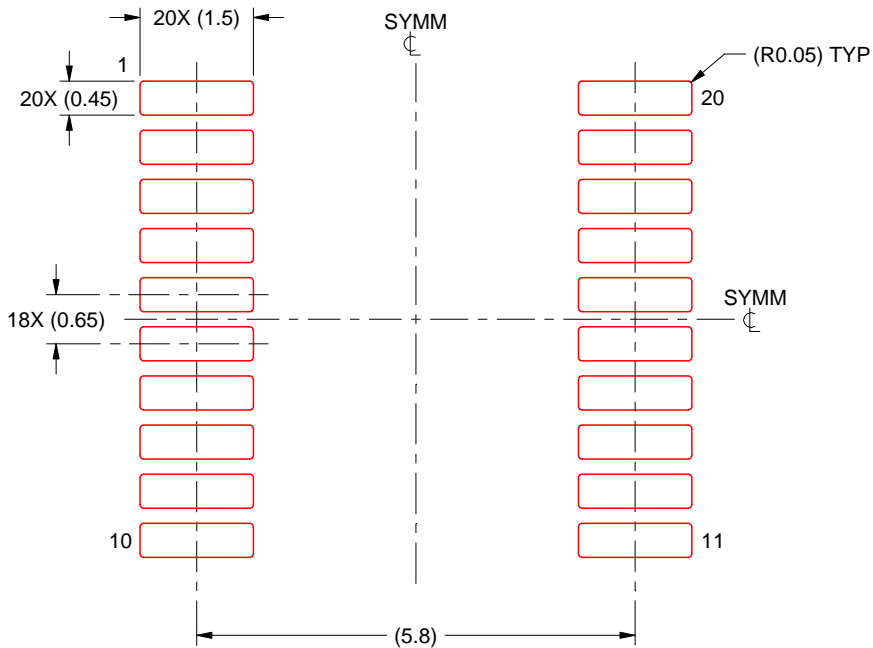

SOLDER PASTE EXAMPLE
BASED ON 0.125 mm THICK STENCIL
SCALE: 10X

4220206/A 02/2017

NOTES: (continued)

8. Laser cutting apertures with trapezoidal walls and rounded corners may offer better paste release. IPC-7525 may have alternate design recommendations.
9. Board assembly site may have different recommendations for stencil design.

DGS0020A



PACKAGE OUTLINE

VSSOP - 1.1 mm max height

SMALL OUTLINE PACKAGE

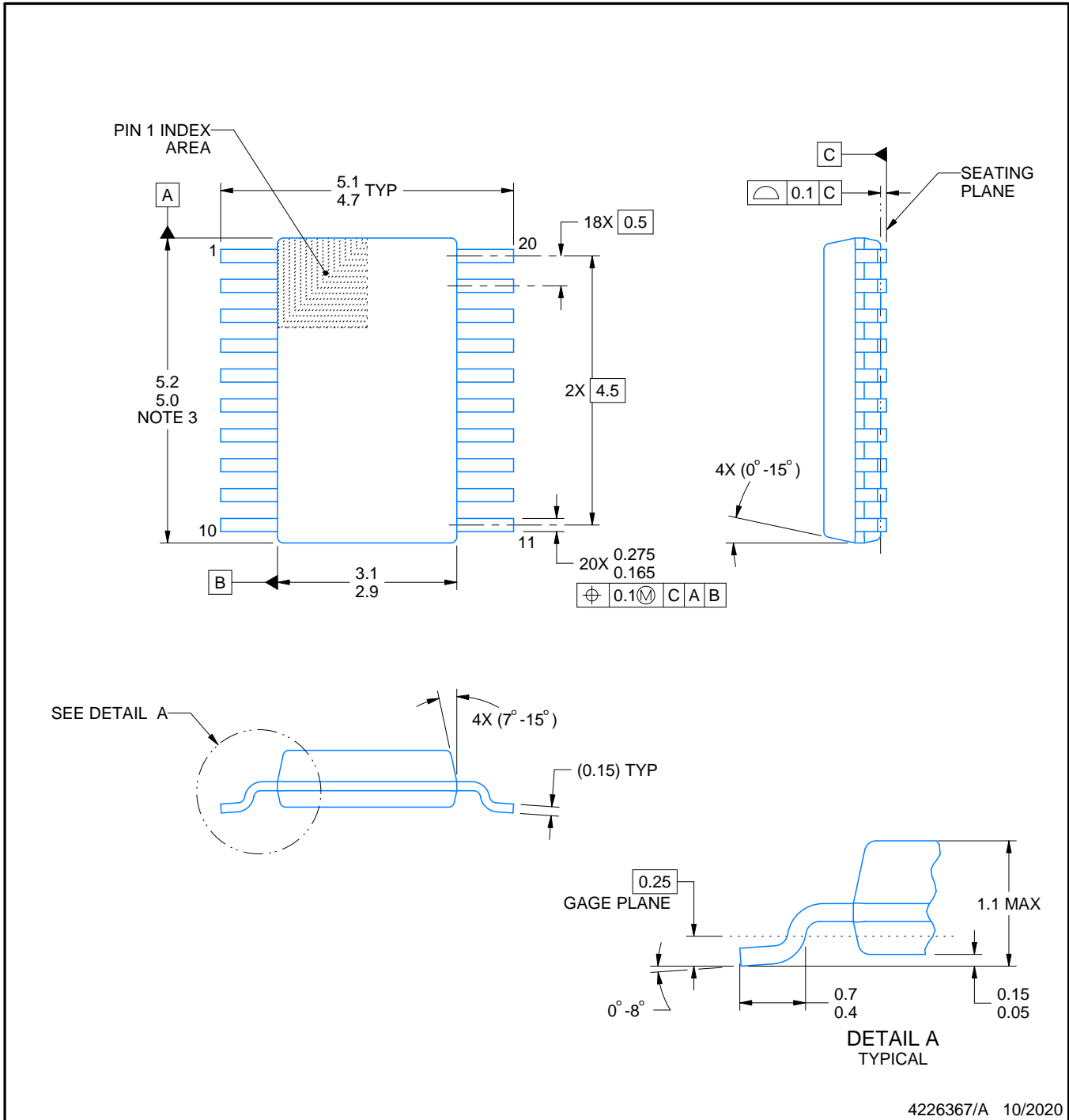

4226367/A 10/2020

NOTES:

PowerPAD is a trademark of Texas Instruments.

1. All linear dimensions are in millimeters. Any dimensions in parenthesis are for reference only. Dimensioning and tolerancing per ASME Y14.5M.
2. This drawing is subject to change without notice.
3. This dimension does not include mold flash, protrusions, or gate burrs. Mold flash, protrusions, or gate burrs shall not exceed 0.15 mm per side.
4. No JEDEC registration as of September 2020.
5. Features may differ or may not be present.

EXAMPLE BOARD LAYOUT

DGS0020A

VSSOP - 1.1 mm max height

SMALL OUTLINE PACKAGE

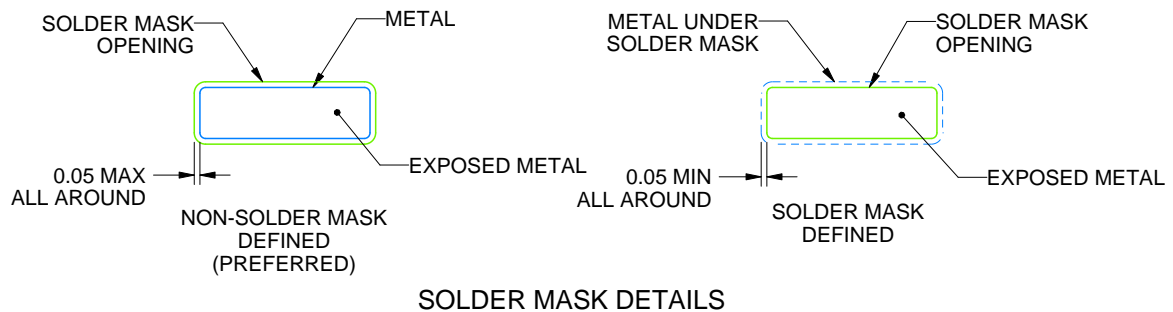
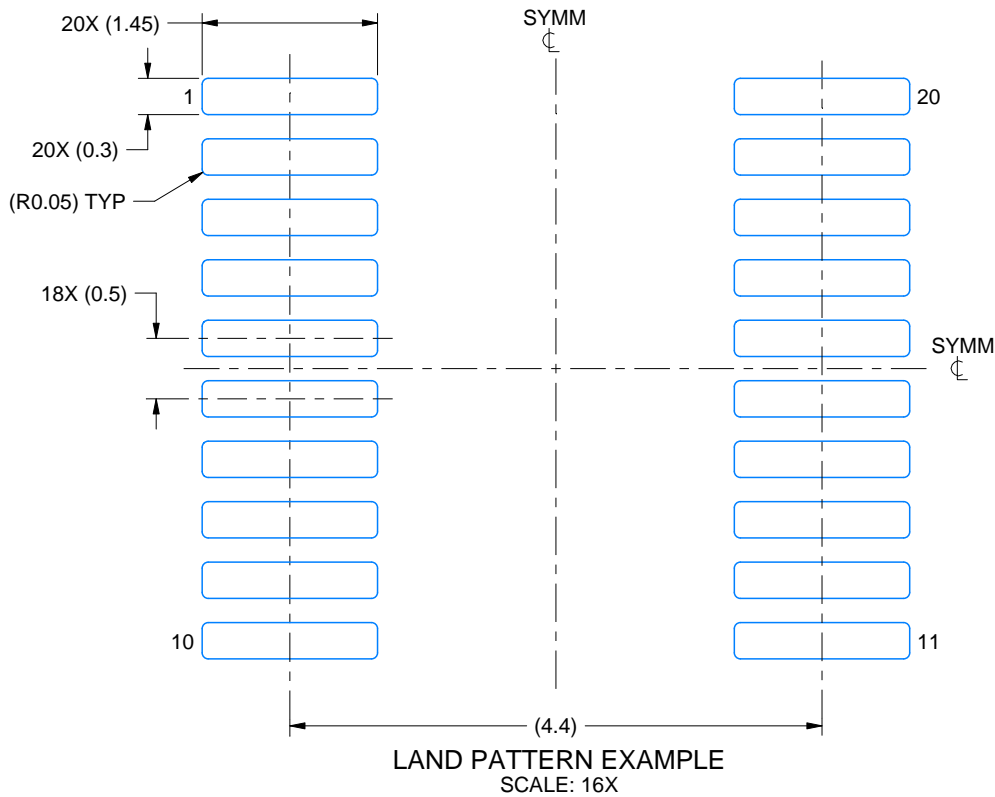

4226367/A 10/2020

NOTES: (continued)

6. Publication IPC-7351 may have alternate designs.
7. Solder mask tolerances between and around signal pads can vary based on board fabrication site.
8. This package is designed to be soldered to a thermal pad on the board. For more information, see Texas Instruments literature numbers SLMA002 (www.ti.com/lit/slma002) and SLMA004 (www.ti.com/lit/slma004).
9. Size of metal pad may vary due to creepage requirement.
10. Vias are optional depending on application, refer to device data sheet. It is recommended that vias under paste be filled, plugged or tented.

EXAMPLE STENCIL DESIGN

DGS0020A

VSSOP - 1.1 mm max height

SMALL OUTLINE PACKAGE

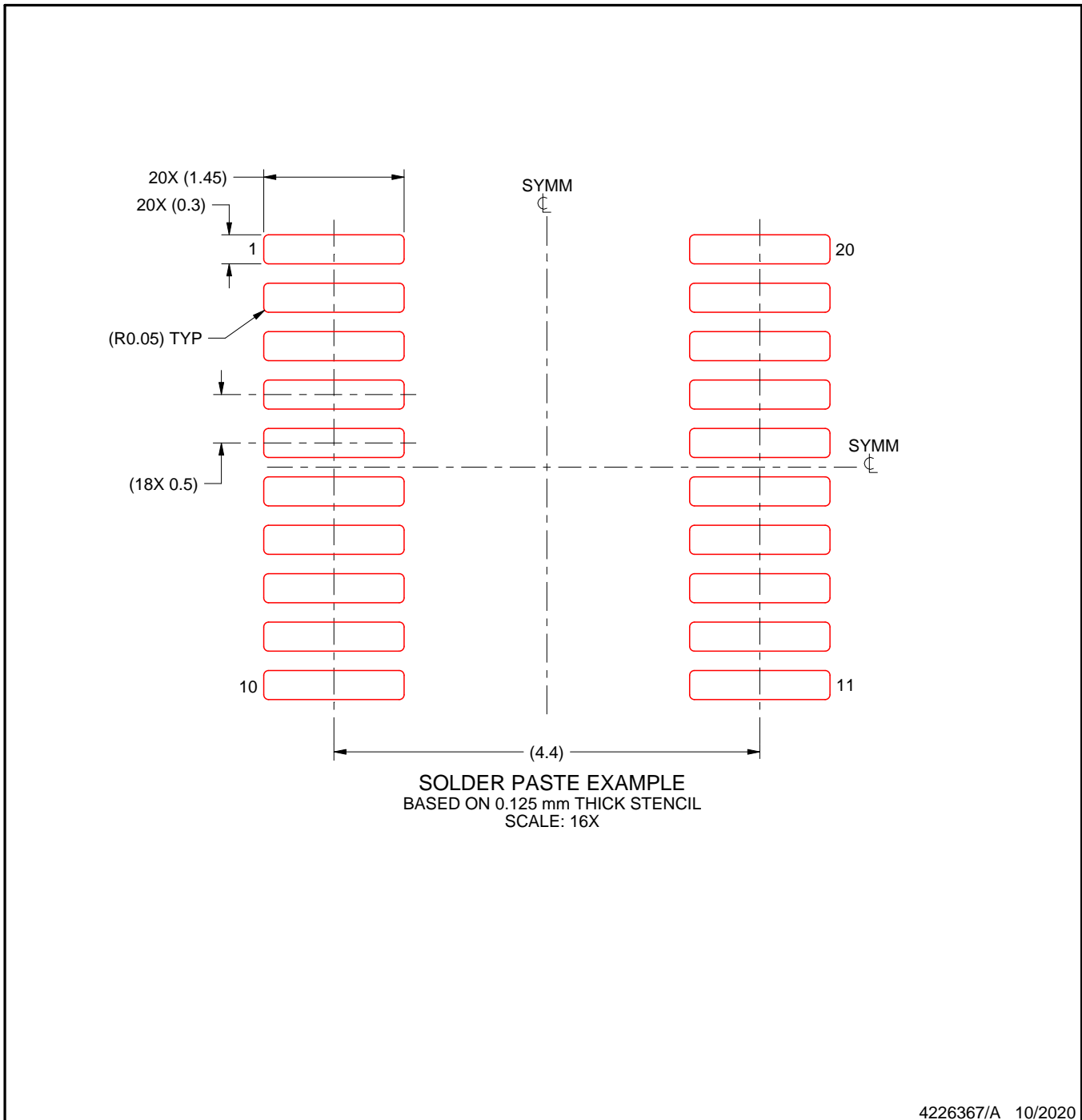

NOTES: (continued)

11. Laser cutting apertures with trapezoidal walls and rounded corners may offer better paste release. IPC-7525 may have alternate design recommendations.
12. Board assembly site may have different recommendations for stencil design.

DB0020A

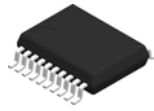

PACKAGE OUTLINE

SSOP - 2 mm max height

SMALL OUTLINE PACKAGE

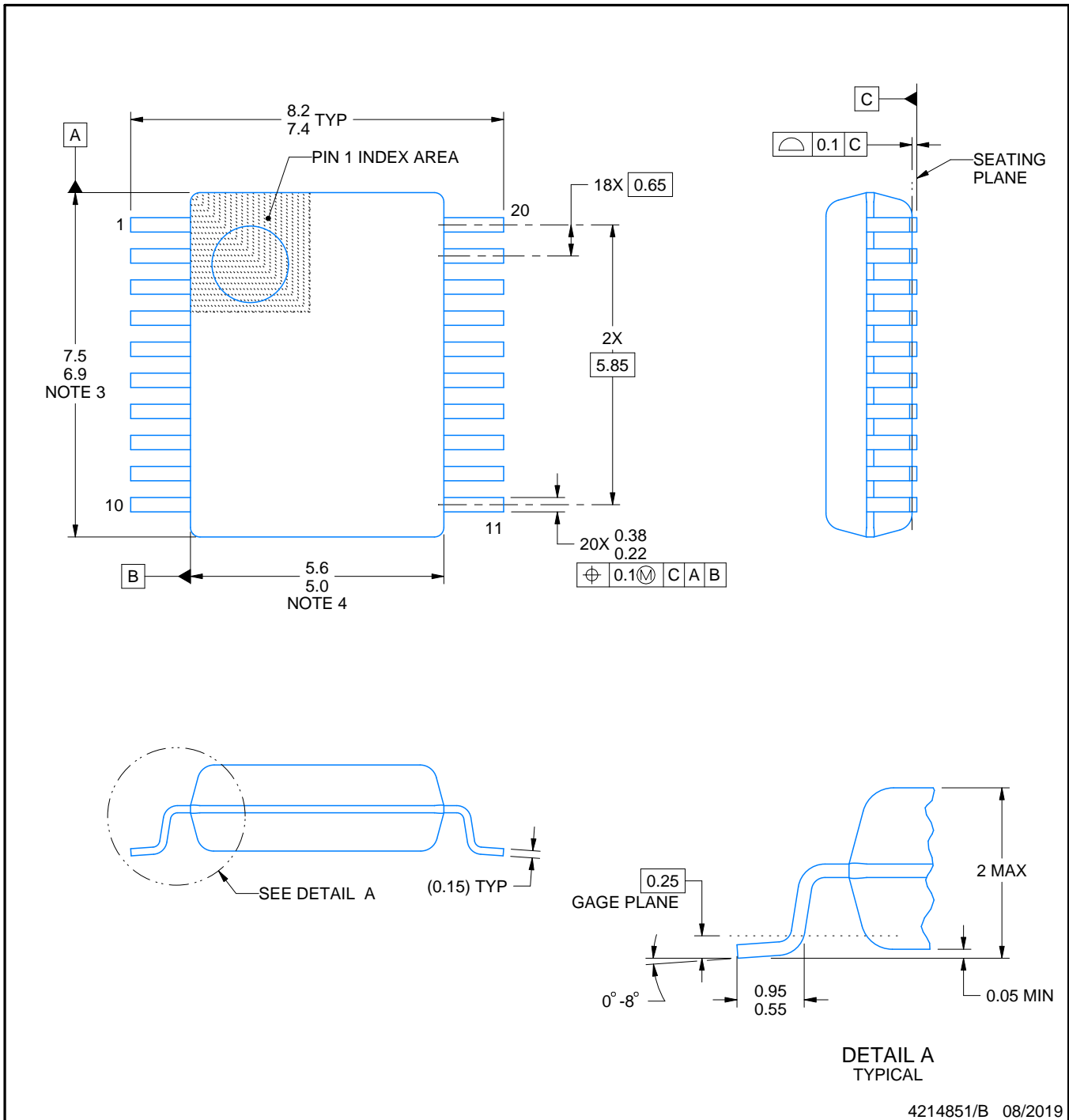

4214851/B 08/2019

NOTES:

1. All linear dimensions are in millimeters. Any dimensions in parenthesis are for reference only. Dimensioning and tolerancing per ASME Y14.5M.
2. This drawing is subject to change without notice.
3. This dimension does not include mold flash, protrusions, or gate burrs. Mold flash, protrusions, or gate burrs shall not exceed 0.15 mm per side.
4. This dimension does not include interlead flash. Interlead flash shall not exceed 0.25 mm per side.
5. Reference JEDEC registration MO-150.

EXAMPLE BOARD LAYOUT

DB0020A

SSOP - 2 mm max height

SMALL OUTLINE PACKAGE

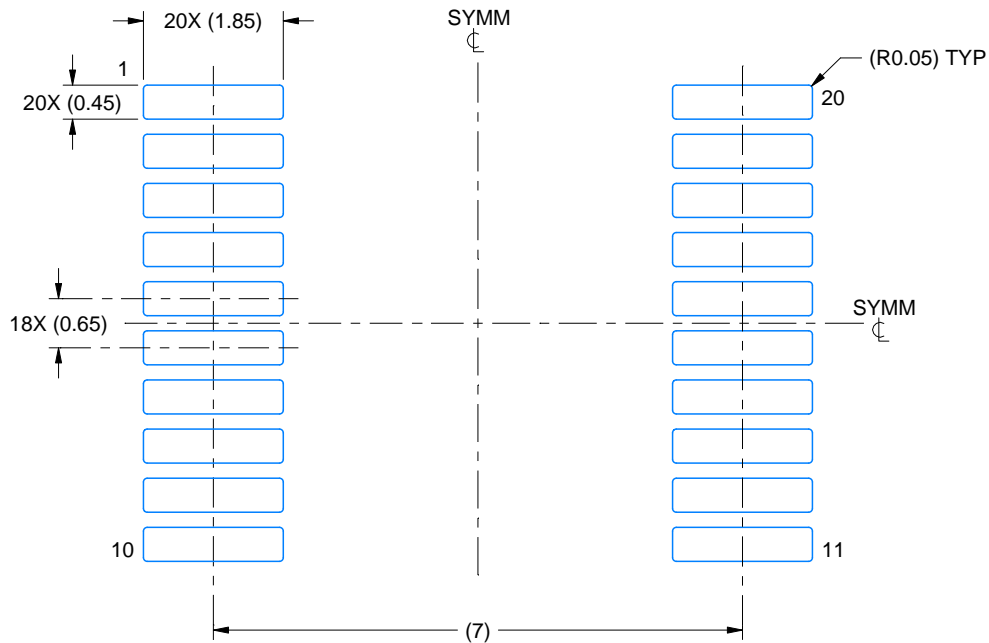

LAND PATTERN EXAMPLE
EXPOSED METAL SHOWN
SCALE: 10X

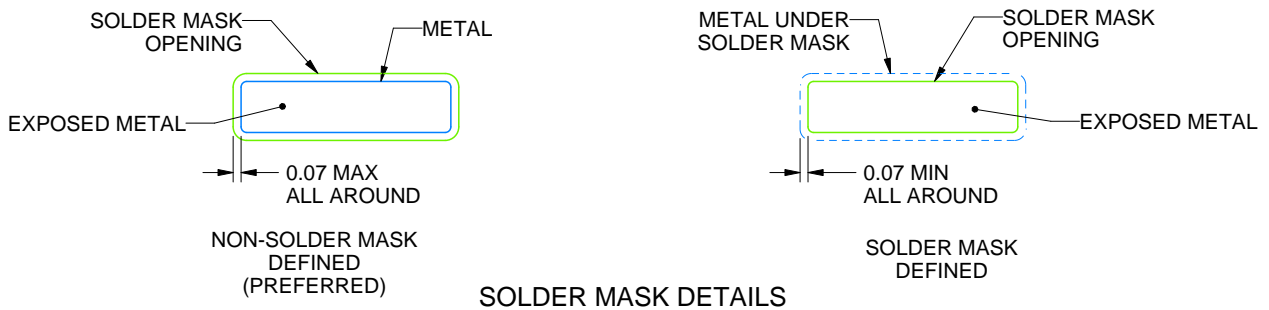

4214851/B 08/2019

NOTES: (continued)

- 6. Publication IPC-7351 may have alternate designs.
- 7. Solder mask tolerances between and around signal pads can vary based on board fabrication site.

EXAMPLE STENCIL DESIGN

DB0020A

SSOP - 2 mm max height

SMALL OUTLINE PACKAGE

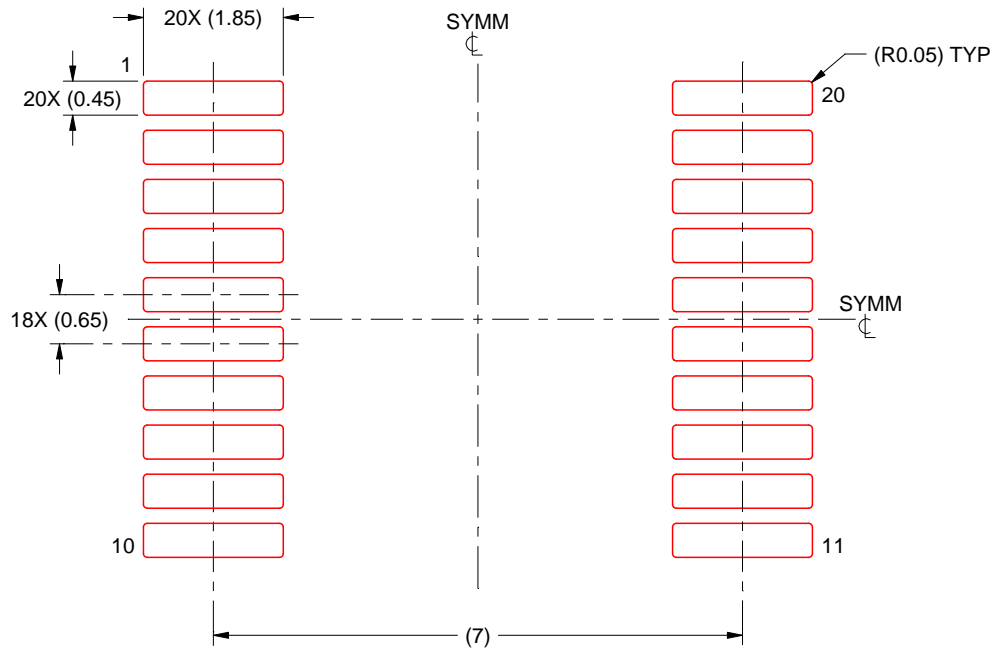

SOLDER PASTE EXAMPLE
BASED ON 0.125 mm THICK STENCIL
SCALE: 10X

4214851/B 08/2019

NOTES: (continued)

8. Laser cutting apertures with trapezoidal walls and rounded corners may offer better paste release. IPC-7525 may have alternate design recommendations.
9. Board assembly site may have different recommendations for stencil design.

GENERIC PACKAGE VIEW

RKS 20

VQFN - 1 mm max height

2.5 x 4.5, 0.5 mm pitch

PLASTIC QUAD FLATPACK - NO LEAD

This image is a representation of the package family, actual package may vary.
Refer to the product data sheet for package details.

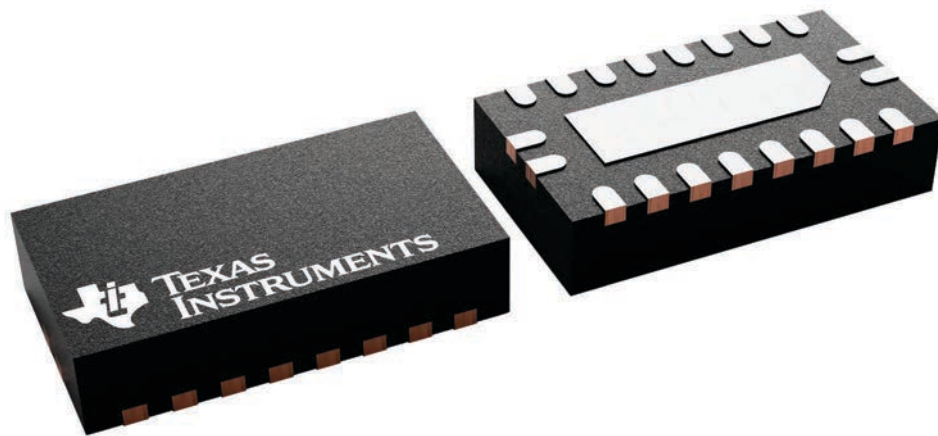

4226872/A

MECHANICAL DATA

NS (R-PDSO-G**)

PLASTIC SMALL-OUTLINE PACKAGE

14-PINS SHOWN

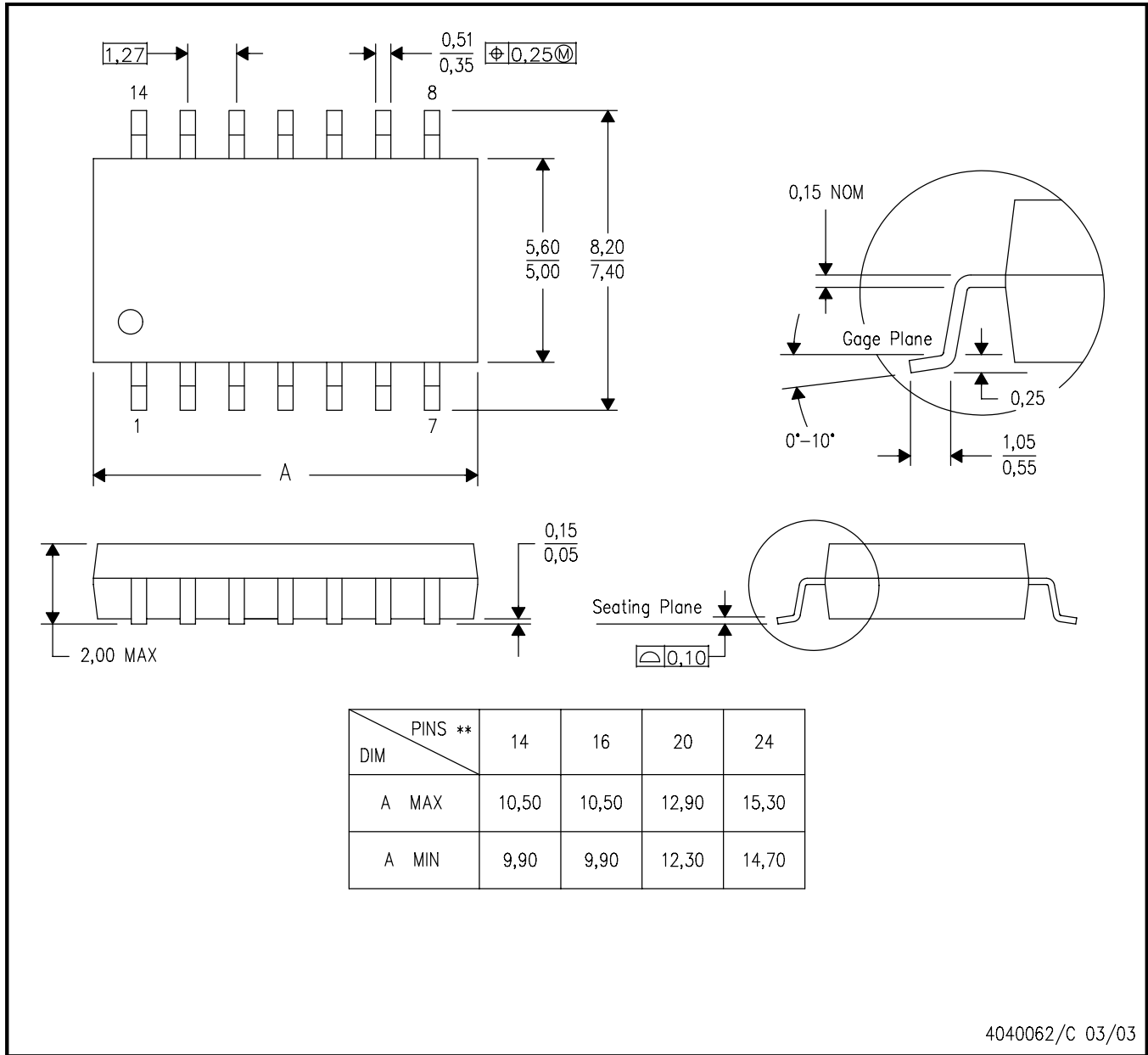

- NOTES:
- A. All linear dimensions are in millimeters.
 - B. This drawing is subject to change without notice.
 - C. Body dimensions do not include mold flash or protrusion, not to exceed 0,15.

IMPORTANT NOTICE AND DISCLAIMER

TI PROVIDES TECHNICAL AND RELIABILITY DATA (INCLUDING DATASHEETS), DESIGN RESOURCES (INCLUDING REFERENCE DESIGNS), APPLICATION OR OTHER DESIGN ADVICE, WEB TOOLS, SAFETY INFORMATION, AND OTHER RESOURCES "AS IS" AND WITH ALL FAULTS, AND DISCLAIMS ALL WARRANTIES, EXPRESS AND IMPLIED, INCLUDING WITHOUT LIMITATION ANY IMPLIED WARRANTIES OF MERCHANTABILITY, FITNESS FOR A PARTICULAR PURPOSE OR NON-INFRINGEMENT OF THIRD PARTY INTELLECTUAL PROPERTY RIGHTS.

These resources are intended for skilled developers designing with TI products. You are solely responsible for (1) selecting the appropriate TI products for your application, (2) designing, validating and testing your application, and (3) ensuring your application meets applicable standards, and any other safety, security, regulatory or other requirements.

These resources are subject to change without notice. TI grants you permission to use these resources only for development of an application that uses the TI products described in the resource. Other reproduction and display of these resources is prohibited. No license is granted to any other TI intellectual property right or to any third party intellectual property right. TI disclaims responsibility for, and you fully indemnify TI and its representatives against any claims, damages, costs, losses, and liabilities arising out of your use of these resources.

TI's products are provided subject to [TI's Terms of Sale](#), [TI's General Quality Guidelines](#), or other applicable terms available either on ti.com or provided in conjunction with such TI products. TI's provision of these resources does not expand or otherwise alter TI's applicable warranties or warranty disclaimers for TI products. Unless TI explicitly designates a product as custom or customer-specified, TI products are standard, catalog, general purpose devices.

TI objects to and rejects any additional or different terms you may propose.

Copyright © 2026, Texas Instruments Incorporated

Last updated 10/2025