

THVD1400, THVD1420 3.3-V to 5-V RS-485 Transceivers in Small Package with ± 12 -kV IEC ESD Protection

1 Features

- Meets or exceeds the requirements of the TIA/EIA-485A standard
- 3-V to 5.5-V Supply voltage
- Half-duplex RS-422/RS-485
- Data rates
 - THVD1400: 500 kbps
 - THVD1420: 12 Mbps
- Bus I/O protection
 - ± 16 -kV HBM ESD
 - ± 12 -kV IEC 61000-4-2 Contact discharge
 - ± 15 -kV IEC 61000-4-2 Air gap discharge
 - ± 4 -kV IEC 61000-4-4 Fast transient burst
 - ± 16 -V bus fault protection (absolute max voltage on bus pins)
- Small, space-saving 8-pin SOT package option (2.1 mm x 1.2 mm)
 - See the [layout example](#) for co-layout with standard SOIC-8 package
- Extended industrial temperature range: -40°C to 125°C
- Large receiver hysteresis for noise rejection
- Low power consumption
 - Low standby supply current: $< 1\ \mu\text{A}$
 - Quiescent current during operation: 1.5 mA (typ)
- Glitch-free power-up/down for hot plug-in capability
- Open, short, and idle bus failsafe
- 1/8 Unit load (Up to 256 bus nodes)

2 Applications

- [Factory automation & control](#)
- [Building automation](#)
- [Grid infrastructure](#)
- [Motor drives](#)
- [Power delivery](#)
- [Industrial transport](#)
- [HVAC systems](#)
- [Video surveillance](#)
- [Smart meters](#)

Description

THVD1400 and THVD1420 are robust half-duplex RS-485 transceivers for industrial applications. The bus pins are immune to high levels of IEC Contact Discharge ESD events, eliminating the need for additional system level protection components.

The devices operate from a single 3 to 5.5-V supply. The wide common-mode voltage range and low input leakage on bus pins make the devices suitable for multi-point applications over long cable runs.

THVD1400 and THVD1420 are available in industry standard, 8-pin SOIC package for drop-in compatibility as well as in the industry-leading, small SOT package. The devices are characterized for ambient temperatures from -40°C to 125°C .

Device Information

PART NUMBER	PACKAGE ⁽¹⁾	BODY SIZE (NOM)
THVD1400	SOT (8)	2.1 mm x 1.2 mm
THVD1420	SOIC (8)	4.90 mm x 3.91 mm

- (1) For all available packages, see the orderable addendum at the end of the data sheet.

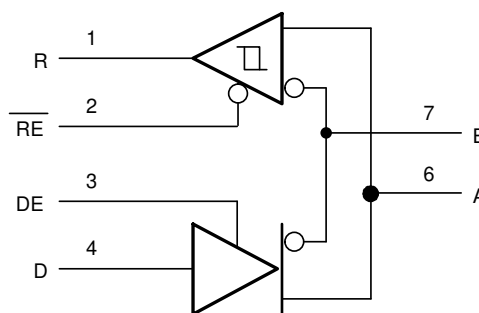

Simplified Schematic



Table of Contents

1 Features	1	7.3 Feature Description.....	13
2 Applications	1	7.4 Device Functional Modes.....	13
3 Revision History	2	8 Application Information Disclaimer	15
4 Pin Configuration and Functions	3	8.1 Application Information.....	15
5 Specifications	4	8.2 Typical Application.....	15
5.1 Absolute Maximum Ratings.....	4	9 Power Supply Recommendations	19
5.2 ESD Ratings.....	4	10 Layout	20
5.3 ESD Ratings [IEC].....	4	10.1 Layout Guidelines.....	20
5.4 Recommended Operating Conditions.....	5	10.2 Layout Example.....	20
5.5 Thermal Information.....	5	11 Device and Documentation Support	22
5.6 Power Dissipation Characteristics.....	5	11.1 Device Support.....	22
5.7 Electrical Characteristics.....	6	11.2 Receiving Notification of Documentation Updates..	22
5.8 Switching Characteristics (THVD1400).....	7	11.3 Support Resources.....	22
5.9 Switching Characteristics (THVD1420).....	7	11.4 Trademarks.....	22
5.10 Typical Characteristics.....	9	11.5 Electrostatic Discharge Caution.....	22
6 Parameter Measurement Information	11	11.6 Glossary.....	22
7 Detailed Description	13	12 Mechanical, Packaging, and Orderable Information	22
7.1 Overview.....	13		
7.2 Functional Block Diagrams.....	13		

3 Revision History

NOTE: Page numbers for previous revisions may differ from page numbers in the current version.

Changes from Revision A (April 2021) to Revision B (October 2021)	Page
• Updated IEC ESD Contact rating from 8 kV to 12 kV in the <i>Features</i> section.....	1
• Changed HBM rating for non-bus pins from 1kV to 4kV in the <i>ESD Ratings table</i>	4
• Changed the IEC ESD contact rating for bus pins from 8kV to 12kV in the <i>ESD Ratings [IEC] table</i>	4
• Updated the V_{IH} max specification for the logic input pins from V_{CC} to 5.5 V in the <i>Recommended Operating Conditions</i> table.....	5
• Updated IEC ESD Contact rating from 8 kV to 12 kV in the <i>Features Description</i> section.....	13
• Updated IEC ESD Contact rating from 8 kV to 12 kV in the <i>Transient Protection</i> section.....	17

Changes from Revision * (December 2020) to Revision A (April 2021)	Page
• Added <i>Feature</i> : See the layout example	1
• Deleted the Advanced Information note from THVD1420 in the <i>Device Information</i> table.....	1
• Added Figure 5-7 , Figure 5-8 and Figure 5-9	9
• Added test conditions for Figure 5-1 , Figure 5-2 , Figure 5-4 and Figure 5-5	9
• Added Figure 10-2	20

4 Pin Configuration and Functions

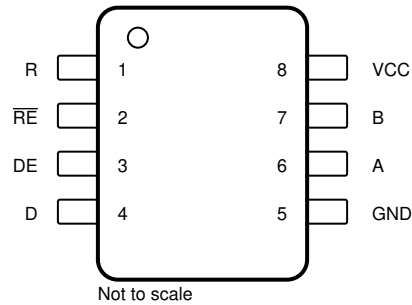

Figure 4-1. SOIC-8 (D), SOT-8 (DRL) Package, Top View

Table 4-1. Pin Functions

PIN		I/O	DESCRIPTION
NAME	NO.		
R	1	Digital output	Receive data output
\overline{RE}	2	Digital input	Receiver enable, active low (internal 2-M Ω pull-up)
DE	3	Digital input	Driver enable, active high (internal 2-M Ω pull-down)
D	4	Digital input	Driver data input
GND	5	Ground	Device ground
A	6	Bus input/output	Bus I/O port, A (complementary to B)
B	7	Bus input/output	Bus I/O port, B (complementary to A)
V _{CC}	8	Power	3.3-V to 5-V supply

5 Specifications

5.1 Absolute Maximum Ratings

over operating free-air temperature range, unless otherwise noted (see ⁽¹⁾)

		MIN	MAX	UNIT
V _{CC}	Supply voltage	-0.5	7	V
V _L	Input voltage at any logic pin (D, DE or RE)	-0.3	5.7	V
V _A , V _B	Voltage at A or B inputs	-16	16	V
I _O	Receiver output current	-24	24	mA
T _J	Junction temperature		170	°C
T _{STG}	Storage temperature	-65	150	°C

- (1) Operation outside the Absolute Maximum Ratings may cause permanent device damage. Absolute maximum ratings do not imply functional operation of the device at these or any other conditions beyond those listed under Recommended Operating Conditions. If briefly operating outside the Recommended Operating Conditions but within the Absolute Maximum Ratings, the device may not sustain damage, but it may not be fully functional. Operating the device in this manner may affect device reliability, functionality, performance, and shorten the device lifetime.

5.2 ESD Ratings

			VALUE	UNIT
V _(ESD)	Electrostatic discharge	Human body model (HBM), per ANSI/ESDA/JEDEC JS-001 ⁽¹⁾	±16,000	V
V _(ESD)	Electrostatic discharge	Human body model (HBM), per ANSI/ESDA/JEDEC JS-001 ⁽¹⁾	±4,000	V
		Charged-device model (CDM), per ANSI/ESDA/JEDEC JS-002 ⁽²⁾	±1,500	

- (1) JEDEC document JEP155 states that 500-V HBM allows safe manufacturing with a standard ESD control process.
 (2) JEDEC document JEP157 states that 250-V CDM allows safe manufacturing with a standard ESD control process.

5.3 ESD Ratings [IEC]

			VALUE	UNIT
V _(ESD)	Electrostatic discharge	IEC 61000-4-2 ESD (Contact Discharge), bus terminals and GND	±12,000	V
	Electrostatic discharge	IEC 61000-4-2 ESD (Air-Gap Discharge), bus terminals and GND	±15,000	
	Electrostatic discharge	IEC 61000-4-4 EFT (Fast transient or burst), bus terminals and GND	±4,000	

5.4 Recommended Operating Conditions

		MIN	NOM	MAX	UNIT
V _{CC}	Supply voltage	3	5	5.5	V
V _{ID}	Differential input voltage	-12		12	V
V _I	Input voltage at any bus terminal ⁽¹⁾	-7		12	V
V _{IH}	High-level input voltage (driver, driver-enable, and receiver-enable inputs)	2		5.5	V
V _{IL}	Low-level input voltage (driver, driver-enable, and receiver-enable inputs)	0		0.8	V
I _O	Output current	Driver		60	mA
		Receiver		8	
R _L	Differential load resistance	54	60		Ω
1/t _{UI}	Signaling rate: THVD1400			500	kbps
1/t _{UI}	Signaling rate: THVD1420			12	Mbps
T _J	Junction temperature	-40		150	°C
T _A ⁽²⁾	Operating ambient temperature	-40		125	°C
T _{SHDN}	Thermal shutdown threshold (temperature rising)	150	170		°C
T _{HYS}	Thermal shutdown hysteresis		15		°C

- (1) The algebraic convention in which the least positive (most negative) limit is designated as minimum is used in this data sheet.
- (2) Operation is specified for internal (junction) temperatures up to 150°C. Self-heating due to internal power dissipation should be considered for each application. Maximum junction temperature is internally limited by the thermal shut-down (TSD) circuit which disables the driver outputs when the junction temperature reaches 170°C.

5.5 Thermal Information

THERMAL METRIC ⁽¹⁾		THVD1400, THVD1420		UNIT
		DRL (SOT)	D (SOIC)	
		8 PINS	8 PINS	
R _{θJA}	Junction-to-ambient thermal resistance	112.2	126.0	°C/W
R _{θJC(top)}	Junction-to-case (top) thermal resistance	28.4	66.2	°C/W
R _{θJB}	Junction-to-board thermal resistance	22.1	69.4	°C/W
ψ _{JT}	Junction-to-top characterization parameter	1.2	18.7	°C/W
ψ _{JB}	Junction-to-board characterization parameter	22.0	68.7	°C/W

- (1) For more information about traditional and new thermal metrics, see the [Semiconductor and IC Package Thermal Metrics](#) application report.

5.6 Power Dissipation Characteristics

PARAMETER		TEST CONDITIONS		VALUE	UNIT
P _D	Power dissipation, driver and receiver enabled, V _{CC} = 5.5 V, T _A = 125°C, 50% duty cycle square-wave signal at maximum signaling rate (THVD1400)	Unterminated	R _L = 300 Ω, C _L = 50 pF	145	mW
		RS-422 load	R _L = 100 Ω, C _L = 50 pF	175	
		RS-485 load	R _L = 54 Ω, C _L = 50 pF	235	
	Power dissipation, driver and receiver enabled, V _{CC} = 5.5 V, T _A = 125°C, 50% duty cycle square-wave signal at maximum signaling rate (THVD1420)	Unterminated	R _L = 300 Ω, C _L = 50 pF	175	mW
		RS-422 load	R _L = 100 Ω, C _L = 50 pF	200	
		RS-485 load	R _L = 54 Ω, C _L = 50 pF	250	

5.7 Electrical Characteristics

over operating free-air temperature range (unless otherwise noted)

PARAMETER		TEST CONDITIONS		MIN	TYP	MAX	UNIT
Driver							
V _{OD}	Driver differential-output voltage magnitude	R _L = 60 Ω, -7 V ≤ V _{test} ≤ 12 V	See Figure 6-1	1.5	2	V	
		R _L = 60 Ω, -7 V ≤ V _{test} ≤ 12 V, 4.5 V ≤ V _{CC} ≤ 5.5 V		2.1	3		
		R _L = 100 Ω, C _L = 50 pF	See Figure 6-2	2	2.5		
		R _L = 54 Ω, C _L = 50 pF		1.5	2		
		R _L = 54 Ω, 4.5 V ≤ V _{CC} ≤ 5.5 V		2.1	3		
Δ V _{OD}	Change in magnitude of driver differential-output voltage	R _L = 54 Ω or 100 Ω, C _L = 50 pF	See Figure 6-2	-50		50	mV
V _{OC(SS)}	Steady-state common-mode output voltage			1	V _{CC} / 2	3	V
ΔV _{OC}	Change in differential driver common-mode output voltage			-50		50	mV
V _{OC(PP)}	Peak-to-peak driver common-mode output voltage	R _L = 54 Ω, C _L = 50 pF, V _{CC} = 5 V	See Figure 6-2		520		mV
V _{OC(PP)}	Peak-to-peak driver common-mode output voltage	R _L = 54 Ω, C _L = 50 pF, V _{CC} = 3.3 V	See Figure 6-2		250		mV
I _{OS}	Driver short-circuit output current	DE = V _{CC} , -7 V ≤ [V _A or V _B] ≤ 12 V, or A pin shorted to B pin		-250		250	mA
Receiver							
I _I	Bus input current (driver disabled)	DE = 0 V, V _{CC} = 0 V or 5.5 V	V _I = 12 V		75	100	μA
			V _I = -7 V	-97	-70		
V _{IT+}	Positive-going receiver differential-input voltage threshold	-7 V ≤ V _{CM} ≤ 12 V			-70	-45	mV
V _{IT-}	Negative-going receiver differential-input voltage threshold			-200	-150	mV	
V _{HYS} ⁽¹⁾	Receiver differential-input voltage threshold hysteresis (V _{IT+} - V _{IT-})			30	50	mV	
V _{OH}	Receiver high-level output voltage	I _{OH} = -4 mA		V _{CC} - 0.4	V _{CC} - 0.2		V
V _{OL}	Receiver low-level output voltage	I _{OL} = 4 mA			0.2	0.4	V
I _{OZ}	Receiver high-impedance output current	V _O = 0 V or V _{CC} , RE = V _{CC}		-1		1	μA
Logic							
I _{IN}	Input current (D, DE, RE)			-5		5	μA
Supply							

5.7 Electrical Characteristics (continued)

over operating free-air temperature range (unless otherwise noted)

PARAMETER		TEST CONDITIONS		MIN	TYP	MAX	UNIT	
I _{CC}	Supply current (quiescent)	V _{CC} = 3.6 V	Both driver and receiver enabled	DE = V _{CC} , \overline{RE} = 0, no load		1500	1800	μA
			Driver enabled and receiver disabled	DE = V _{CC} , \overline{RE} = V _{CC} , no load		1000	1500	
			Driver disabled and receiver enabled	DE = 0, \overline{RE} = 0, no load		700	900	
			Both driver and receiver disabled	DE = 0, \overline{RE} = V _{CC} , no load		0.1	1	
		V _{CC} = 5.5 V	Driver and receiver enabled	DE = V _{CC} , \overline{RE} = 0, no load		1700	3000	μA
			Driver enabled, receiver disabled	DE = V _{CC} , \overline{RE} = V _{CC} , no load		1300	2500	
			Driver disabled, receiver enabled	DE = 0, \overline{RE} = 0, no load		800	1000	
			Both driver and receiver disabled	DE = 0, \overline{RE} = V _{CC} , no load		0.1	1	

(1) Under any specific conditions, V_{IT+} is specified to be at least V_{HYS} higher than V_{IT-}.

5.8 Switching Characteristics (THVD1400)

over operating free-air temperature range (unless otherwise noted)

PARAMETER		TEST CONDITIONS		MIN	TYP	MAX	UNIT
Driver							
t _r , t _f	Driver differential output rise and fall times			200	400	600	ns
t _{PHL} , t _{PLH}	Driver propagation delay	See Figure 6-3			250	500	ns
t _{SK(P)}	Driver pulse skew, t _{PHL} - t _{PLH}					15	ns
t _{PHZ} , t _{PLZ}	Driver disable time				80	200	ns
t _{PZH} , t _{PZL}	Driver enable time	Receiver enabled	See Figure 6-4 and Figure 6-5		200	650	ns
		Receiver disabled			4	10	μs
Receiver							
t _r , t _f	Receiver output rise and fall times				13	20	ns
t _{PHL} , t _{PLH}	Receiver propagation delay time	See Figure 6-6			60	110	ns
t _{SK(P)}	Receiver pulse skew, t _{PHL} - t _{PLH}					7	ns
t _{PHZ} , t _{PLZ}	Receiver disable time				30	60	ns
t _{PZL(1)} , t _{PZH(1)} t _{PZL(2)} , t _{PZH(2)}	Receiver enable time	Driver enabled	See Figure 6-7		60	150	ns
		Driver disabled		See Figure 6-8		4	10

5.9 Switching Characteristics (THVD1420)

over operating free-air temperature range (unless otherwise noted)

PARAMETER		TEST CONDITIONS		MIN	TYP	MAX	UNIT
Driver							
t _r , t _f	Driver differential output rise and fall times				15	25	ns
t _{PHL} , t _{PLH}	Driver propagation delay	See Figure 6-3			20	38	ns
t _{SK(P)}	Driver pulse skew, t _{PHL} - t _{PLH}					3.5	ns
t _{PHZ} , t _{PLZ}	Driver disable time				15	38	ns
t _{PZH} , t _{PZL}	Driver enable time	Receiver enabled	See Figure 6-4 and Figure 6-5		15	70	ns
		Receiver disabled			4	10	μs
Receiver							

5.9 Switching Characteristics (THVD1420) (continued)

over operating free-air temperature range (unless otherwise noted)

PARAMETER		TEST CONDITIONS		MIN	TYP	MAX	UNIT
t_r, t_f	Receiver output rise and fall times	See Figure 6-6			10	16	ns
t_{PHL}, t_{PLH}	Receiver propagation delay time				40	75	ns
$t_{SK(P)}$	Receiver pulse skew, $ t_{PHL} - t_{PLH} $					5	ns
t_{PHZ}, t_{PLZ}	Receiver disable time		See Figure 6-7		15	25	ns
$t_{PZL(1)}, t_{PZH(1)}, t_{PZL(2)}, t_{PZH(2)}$	Receiver enable time	Driver enabled			25	170	ns
		Driver disabled	See Figure 6-8		4	10	μ s

5.10 Typical Characteristics

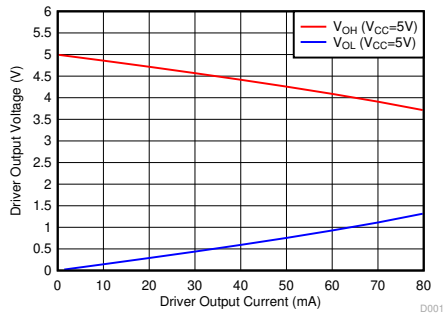

D001_driver_vout_iout.grf

DE = V_{CC} T_A = 25°C

Figure 5-1. Driver Output voltage vs Driver Output Current

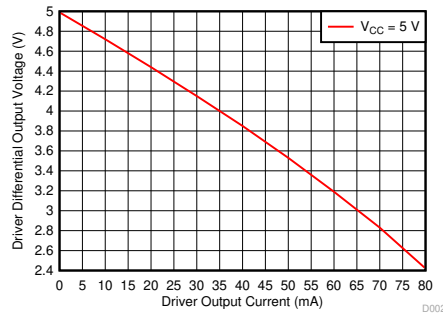

D002_driver_vdiff.grf

DE = V_{CC} D = 0 V T_A = 25°C

Figure 5-2. Driver Differential Output voltage vs Driver Output Current

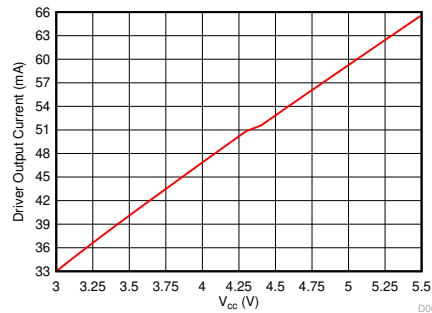

D003_iout_vcc.grf

R_L = 54 Ω DE = V_{CC} D = V_{CC} T_A = 25°C

Figure 5-3. Driver Output Current vs Supply Voltage

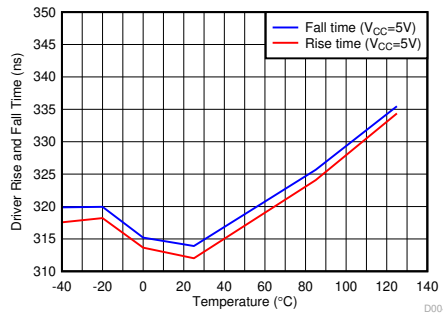

D004_rise_fall.grf

R_L = 54 Ω C_L = 50 pF

Figure 5-4. Driver Rise or Fall Time vs Temperature (THVD1400)

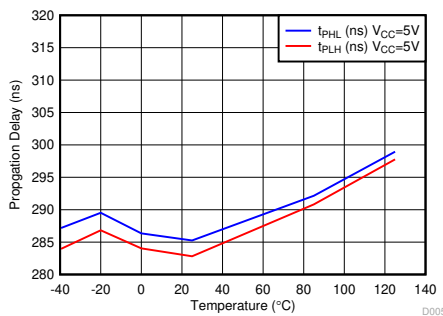

D005_prop_delay.grf

R_L = 54 Ω C_L = 50 pF

Figure 5-5. Driver Propagation Delay vs Temperature (THVD1400)

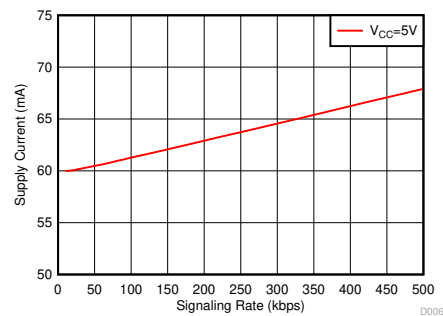

D006_icc_datarate.grf

R_L = 54 Ω T_A = 25°C

Figure 5-6. Supply Current vs Signal Rate (THVD1400)

5.10 Typical Characteristics (continued)

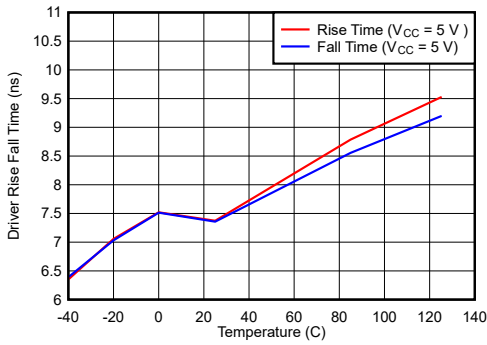

$R_L = 54 \Omega$ $C_L = 50 \text{ pF}$

Figure 5-7. Driver Rise and Fall Time vs Temperature (THVD1420)

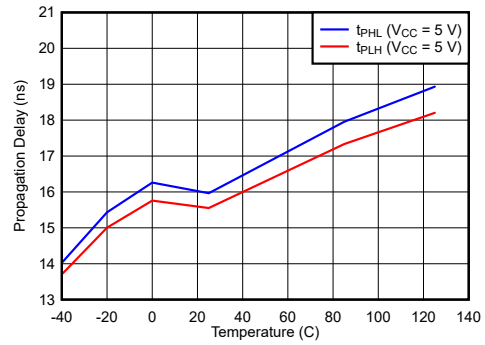

$R_L = 54 \Omega$ $C_L = 50 \text{ pF}$

Figure 5-8. Driver Propagation Delay vs Temperature (THVD1420)

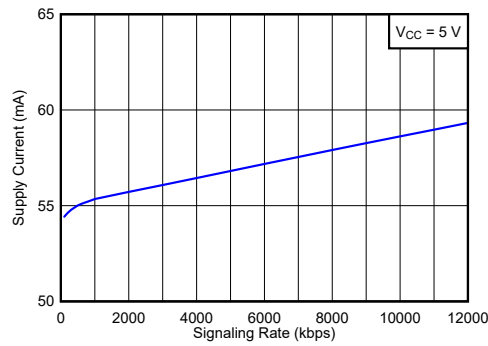

$R_L = 54 \Omega$ $T_A = 25^\circ \text{C}$

Figure 5-9. Supply Current vs Signal Rate (THVD1420)

6 Parameter Measurement Information

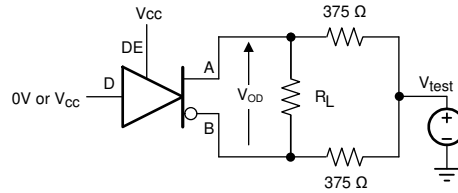

Figure 6-1. Measurement of Driver Differential Output Voltage With Common-Mode Load

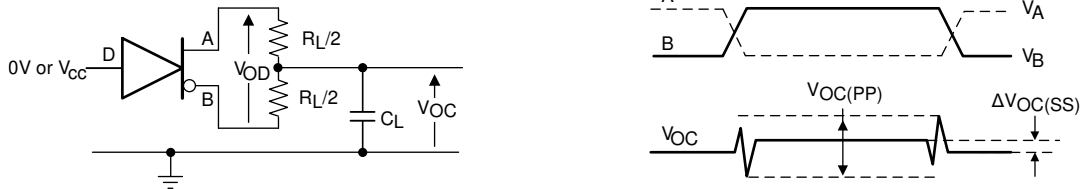

Figure 6-2. Measurement of Driver Differential and Common-Mode Output With RS-485 Load

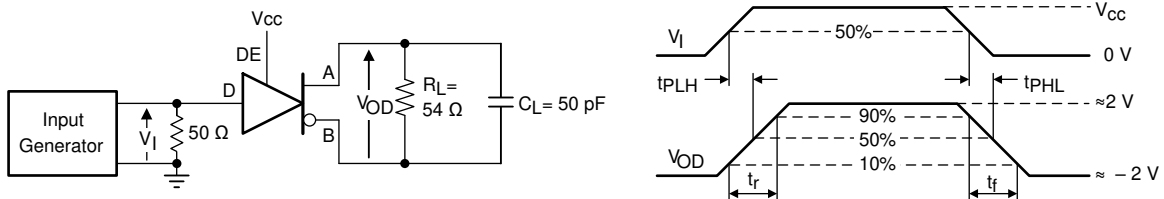

Figure 6-3. Measurement of Driver Differential Output Rise and Fall Times and Propagation Delays

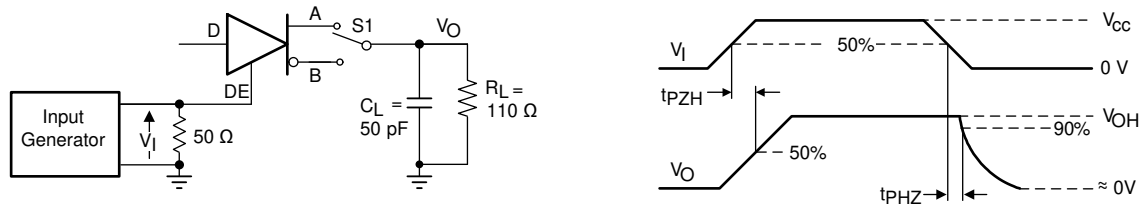

Figure 6-4. Measurement of Driver Enable and Disable Times With Active High Output and Pull-Down Load

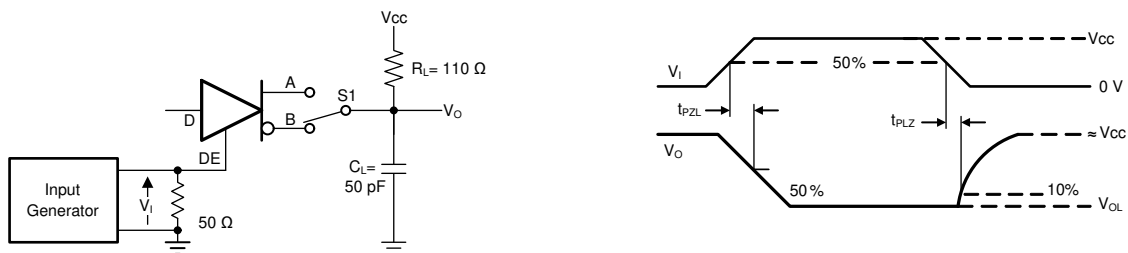

Figure 6-5. Measurement of Driver Enable and Disable Times With Active Low Output and Pull-up Load

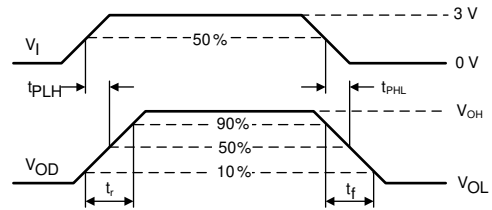
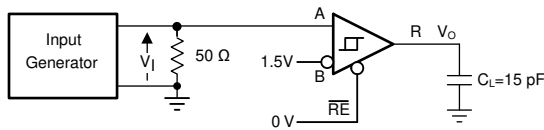

Figure 6-6. Measurement of Receiver Output Rise and Fall Times and Propagation Delays

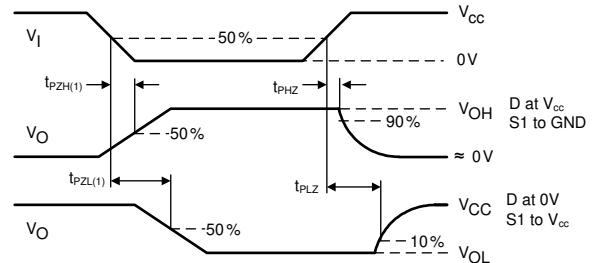
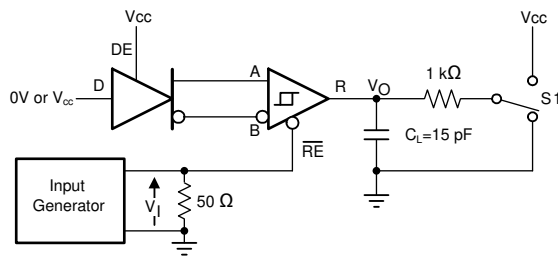

Figure 6-7. Measurement of Receiver Enable/Disable Times With Driver Enabled

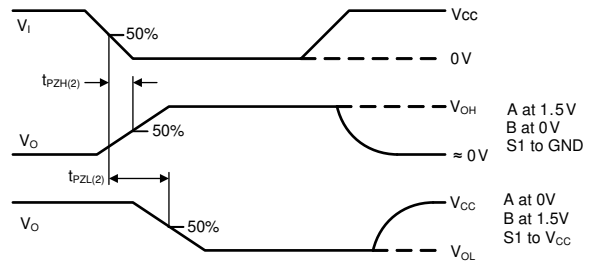
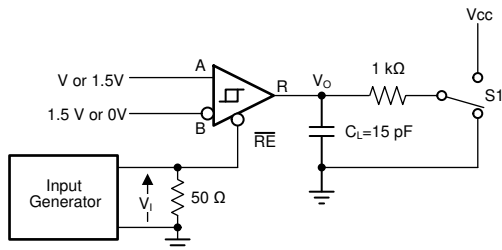

Figure 6-8. Measurement of Receiver Enable Times With Driver Disabled

7 Detailed Description

7.1 Overview

The THVD1400 is a low-power, half-duplex RS-485 transceiver suitable for data transmission up to 500 kbps. The THVD1420 is a low-power, half-duplex RS-485 transceiver suitable for data transmission up to 12 Mbps.

7.2 Functional Block Diagrams

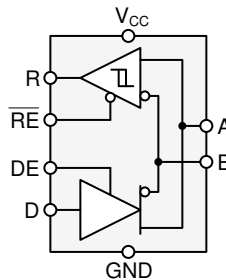

7.3 Feature Description

Internal ESD protection circuits protect the transceiver against Electrostatic Discharges (ESD) according to IEC 61000-4-2 of up to ± 12 kV (Contact Discharge), ± 15 kV (Air Gap Discharge) and against electrical fast transients (EFT) according to IEC 61000-4-4 of up to ± 4 kV.

7.4 Device Functional Modes

When the driver enable pin, DE, is logic high, the differential outputs A and B follow the logic states at data input D. A logic high at D causes A to turn high and B to turn low. In this case, the differential output voltage defined as $V_{OD} = V_A - V_B$ is positive. When D is low, the output states reverse, B turns high, A becomes low, and V_{OD} is negative.

When DE is low, both outputs turn high-impedance. In this condition, the logic state at D is irrelevant. The DE pin has an internal pull-down resistor to ground; thus, when left open, the driver is disabled (high-impedance) by default. The D pin has an internal pull-up resistor to V_{CC} , thus, when left open while the driver is enabled, output A turns high and B turns low.

Table 7-1. Driver Function Table

INPUT D	ENABLE DE	OUTPUTS		FUNCTION
		A	B	
H	H	H	L	Actively drive bus high
L	H	L	H	Actively drive bus low
X	L	Z	Z	Driver disabled
X	OPEN	Z	Z	Driver disabled by default
OPEN	H	H	L	Actively drive bus high by default

When the receiver enable pin, \overline{RE} , is logic low, the receiver is enabled. When the differential input voltage defined as $V_{ID} = V_A - V_B$ is positive and higher than the positive input threshold, V_{IT+} , the receiver output, R, turns high. When V_{ID} is negative and lower than the negative input threshold, V_{IT-} , the receiver output, R, turns low. If V_{ID} is between V_{IT+} and V_{IT-} the output is indeterminate.

When \overline{RE} is logic high or left open, the receiver output is high-impedance and the magnitude and polarity of V_{ID} are irrelevant. Internal biasing of the receiver inputs causes the output to go failsafe-high when the transceiver is disconnected from the bus (open-circuit), the bus lines are shorted (short-circuit), or the bus is not actively driven (idle bus).

Table 7-2. Receiver Function Table

DIFFERENTIAL INPUT	ENABLE	OUTPUT	FUNCTION
$V_{ID} = V_A - V_B$	\overline{RE}	R	
$V_{IT+} < V_{ID}$	L	H	Receive valid bus high
$V_{IT-} < V_{ID} < V_{IT+}$	L	?	Indeterminate bus state
$V_{ID} < V_{IT-}$	L	L	Receive valid bus low
X	H	Z	Receiver disabled
X	OPEN	Z	Receiver disabled by default
Open-circuit bus	L	H	Fail-safe high output
Short-circuit bus	L	H	Fail-safe high output
Idle (terminated) bus	L	H	Fail-safe high output

8 Application Information Disclaimer

Note

Information in the following applications sections is not part of the TI component specification, and TI does not warrant its accuracy or completeness. TI's customers are responsible for determining suitability of components for their purposes, as well as validating and testing their design implementation to confirm system functionality.

8.1 Application Information

The THVD1400 is a half-duplex RS-485 transceiver commonly used for asynchronous data transmissions. The driver and receiver enable pins allow for the configuration of different operating modes.

8.2 Typical Application

An RS-485 bus consists of multiple transceivers connecting in parallel to a bus cable. To eliminate line reflections, each cable end is terminated with a termination resistor, R_T , whose value matches the characteristic impedance, Z_0 , of the cable. This method, known as parallel termination, allows for higher data rates over longer cable length.

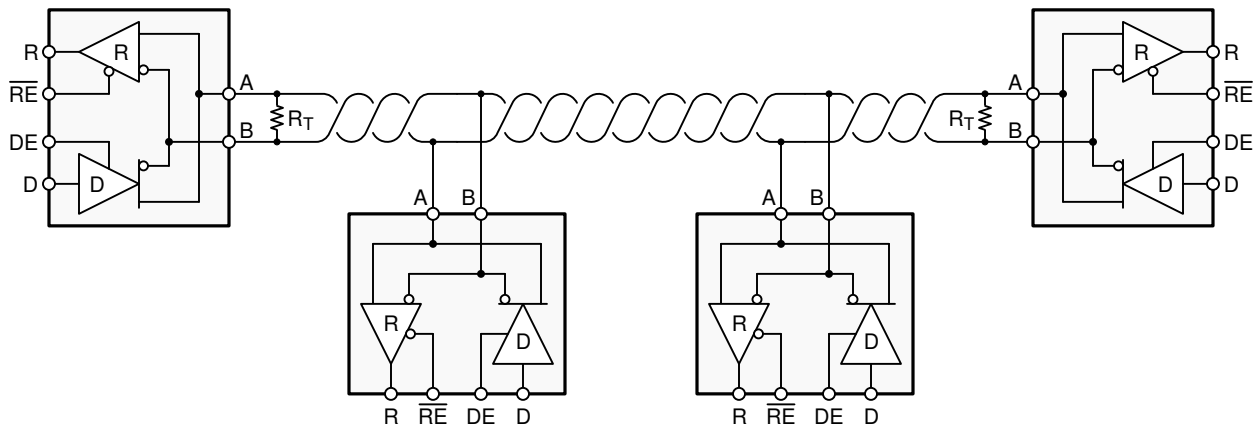

Figure 8-1. Typical RS-485 Network With Half-Duplex Transceivers

8.2.1 Design Requirements

RS-485 is a robust electrical standard suitable for long-distance networking that may be used in a wide range of applications with varying requirements, such as distance, data rate, and number of nodes.

8.2.1.1 Data Rate and Bus Length

There is an inverse relationship between data rate and cable length, which means the higher the data rate, the shorter the cable length; and conversely, the lower the data rate, the longer the cable length. While most RS-485 systems use data rates between 10 kbps and 100 kbps, some applications require data rates up to 300 kbps at distances of 4000 feet and longer. Longer distances are possible by allowing for small signal jitter of up to 5 or 10%.

8.2.1.2 Stub Length

When connecting a node to the bus, the distance between the transceiver inputs and the cable trunk, known as the stub, should be as short as possible. Stubs present a non-terminated piece of bus line which can introduce reflections as the length of the stub increases. As a general guideline, the electrical length, or round-trip delay, of a stub should be less than one-tenth of the rise time of the driver, thus giving a maximum physical stub length as shown in [Equation 1](#).

$$L_{(\text{STUB})} \leq 0.1 \times t_r \times v \times c \quad (1)$$

where

- t_r is the 10/90 rise time of the driver
- c is the speed of light (3×10^8 m/s)
- v is the signal velocity of the cable or trace as a factor of c

8.2.1.3 Bus Loading

The RS-485 standard specifies that a compliant driver must be able to driver 32 unit loads (UL), where 1 unit load represents a load impedance of approximately 12 k Ω . Because the THVD1400 consists of 1/8 UL transceivers, connecting up to 256 receivers to the bus is possible.

8.2.1.4 Receiver Failsafe

The differential receivers of the THVD1400 are *failsafe* to invalid bus states caused by the following:

- Open bus conditions, such as a disconnected connector
- Shorted bus conditions, such as cable damage shorting the twisted-pair together
- Idle bus conditions that occur when no driver on the bus is actively driving

In any of these cases, the differential receiver outputs a failsafe logic high state so that the output of the receiver is not indeterminate.

Receiver failsafe is accomplished by offsetting the receiver thresholds such that the *input indeterminate* range does not include zero volts differential. To comply with the RS-422 and RS-485 standards, the receiver output must output a high when the differential input V_{ID} is more positive than 200 mV, and must output a low when V_{ID} is more negative than -200 mV. The receiver parameters which determine the failsafe performance are V_{IT+} , V_{IT-} , and V_{HYS} (the separation between V_{IT+} and V_{IT-}). As shown in the [Receiver Function Table](#), differential signals more negative than -200 mV always causes a low receiver output, and differential signals more positive than 200 mV always causes a high receiver output.

When the differential input signal is close to zero, it is still above the V_{IT+} threshold, and the receiver output is high. Only when the differential input is more than V_{HYS} below V_{IT+} does the receiver output transition to a low state. Therefore, the noise immunity of the receiver inputs during a bus fault conditions includes the receiver hysteresis value, V_{HYS} , as well as the value of V_{IT+} .

8.2.1.5 Transient Protection

The bus pins of the THVD1400 transceiver family include on-chip ESD protection against ± 16 -kV HBM and ± 12 -kV IEC 61000-4-2 contact discharge. The International Electrotechnical Commission (IEC) ESD test is far more severe than the HBM ESD test. The 50% higher charge capacitance, $C_{(S)}$, and 78% lower discharge resistance, $R_{(D)}$, of the IEC model produce significantly higher discharge currents than the HBM model.

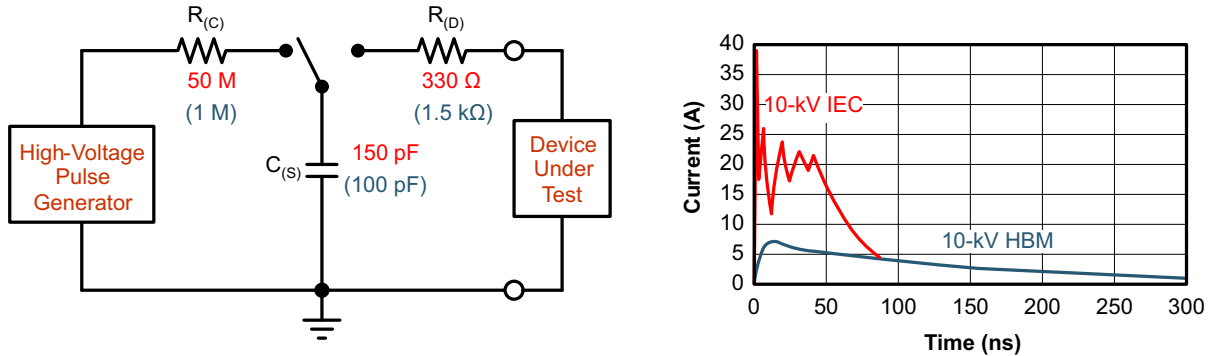

Figure 8-2. HBM and IEC ESD Models and Currents in Comparison (HBM Values in Parenthesis)

The on-chip implementation of IEC ESD protection significantly increases the robustness of equipment. Common discharge events occur because of human contact with connectors and cables. Designers may choose to implement protection against longer duration transients, typically referred to as surge transients.

EFTs are generally caused by relay-contact bounce or the interruption of inductive loads. Surge transients often result from lightning strikes (direct strike or an indirect strike which induce voltages and currents), or the switching of power systems, including load changes and short circuit switching. These transients are often encountered in industrial environments, such as factory automation and power-grid systems.

Figure 8-3 compares the pulse-power of the EFT and surge transients with the power caused by an IEC ESD transient. The left hand diagram shows the relative pulse-power for a 0.5-kV surge transient and 4-kV EFT transient, both of which dwarf the 10-kV ESD transient visible in the lower-left corner. 500-V surge transients are representative of events that may occur in factory environments in industrial and process automation.

The right hand diagram shows the pulse-power of a 6-kV surge transient, relative to the same 0.5-kV surge transient. 6-kV surge transients are most likely to occur in power generation and power-grid systems.

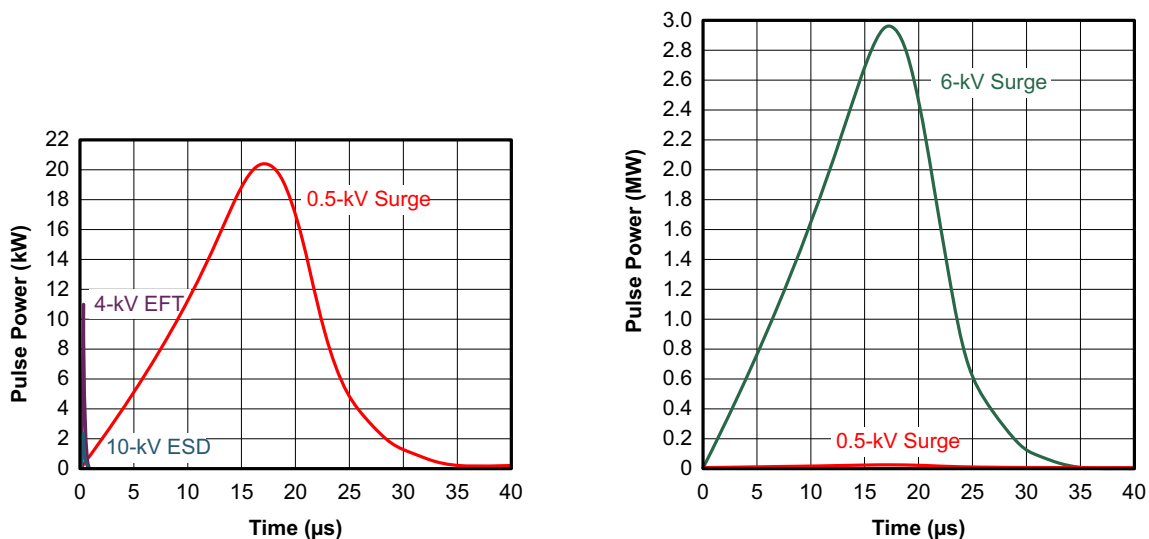

Figure 8-3. Power Comparison of ESD, EFT, and Surge Transients

In the event of surge transients, high-energy content is characterized by long pulse duration and slow decaying pulse power. The electrical energy of a transient that is dumped into the internal protection cells of a transceiver is converted into thermal energy, which heats and destroys the protection cells, thus destroying the transceiver. Figure 8-4 shows the large differences in transient energies for single ESD, EFT, surge transients, and an EFT pulse train that is commonly applied during compliance testing.

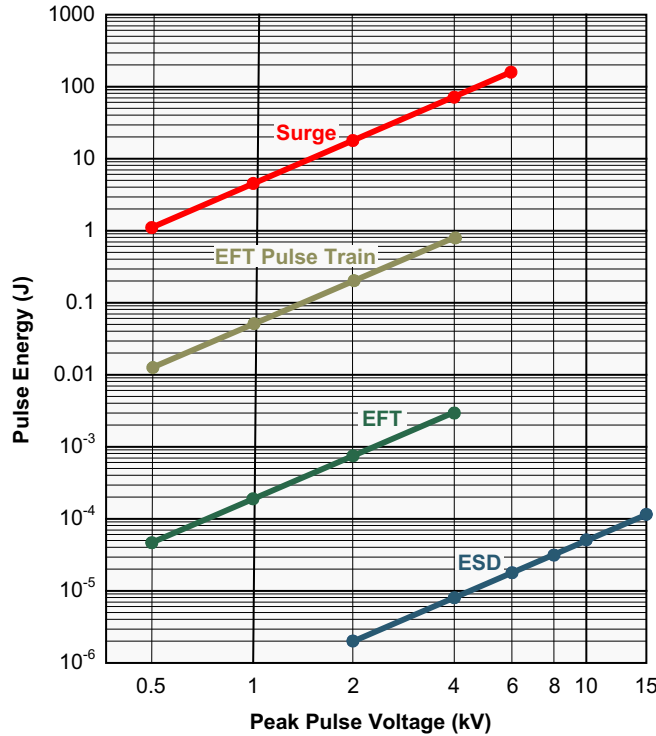

Figure 8-4. Comparison of Transient Energies

8.2.2 Detailed Design Procedure

In order to protect bus nodes against high-energy transients, the implementation of external transient protection devices is necessary. Figure 8-5 suggests a protection circuit against 1 kV surge (IEC 61000-4-5) transients. Table 8-1 shows the associated bill of materials.

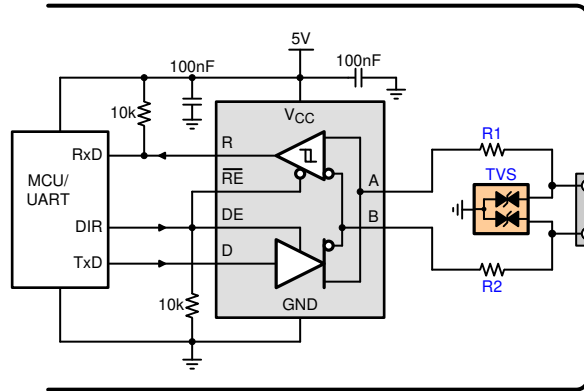

Figure 8-5. Transient Protection Against Surge Transients for Half-Duplex Devices

Table 8-1. Bill of Materials

DEVICE	FUNCTION	ORDER NUMBER	MANUFACTURER
XCVR	RS-485 transceiver	THVD1400	TI
R1	10-Ω, pulse-proof thick-film resistor	CRCW0603010RJNEAHP	Vishay
R2			
TVS	Bidirectional 400-W transient suppressor	CDSOT23-SM712	Bourns

8.2.3 Application Curves

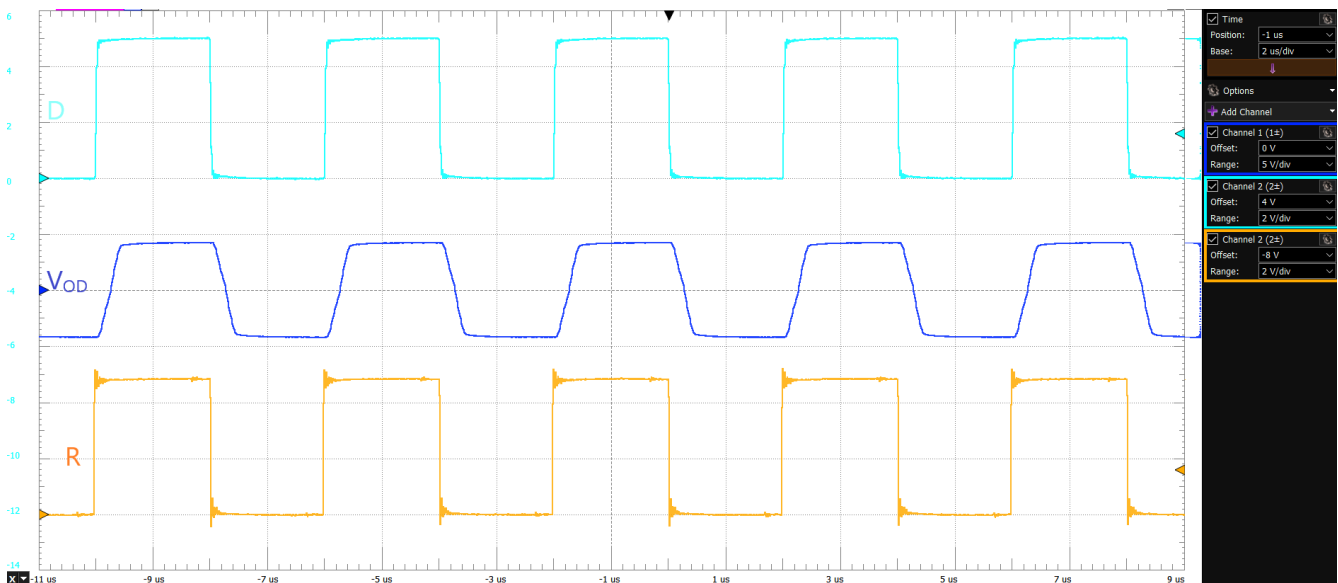

Figure 8-6. THVD1400 waveforms at 500 kbps, $V_{CC} = 5V$

9 Power Supply Recommendations

To ensure reliable operation at all data rates and supply voltages, each supply should be decoupled with a 100 nF ceramic capacitor located as close to the supply pins as possible. This helps to reduce supply voltage ripple present on the outputs of switched-mode power supplies and also helps to compensate for the resistance and inductance of the PCB power planes.

10 Layout

10.1 Layout Guidelines

Robust and reliable bus node design often requires the use of external transient protection devices in order to protect against surge transients that may occur in industrial environments. Since these transients have a wide frequency bandwidth (from approximately 3 MHz to 300 MHz), high-frequency layout techniques should be applied during PCB design.

1. Place the protection circuitry close to the bus connector to prevent noise transients from propagating across the board.
2. Use V_{CC} and ground planes to provide low inductance. Note that high-frequency currents tend to follow the path of least impedance and not the path of least resistance.
3. Design the protection components into the direction of the signal path. Do not force the transient currents to divert from the signal path to reach the protection device.
4. Apply 100-nF to 220-nF decoupling capacitors as close as possible to the V_{CC} pins of transceiver, UART and/or controller ICs on the board.
5. Use at least two vias for V_{CC} and ground connections of decoupling capacitors and protection devices to minimize effective via inductance.
6. Use 1-k Ω to 10-k Ω pull-up and pull-down resistors for enable lines to limit noise currents in these lines during transient events.
7. Insert pulse-proof resistors into the A and B bus lines if the TVS clamping voltage is higher than the specified maximum voltage of the transceiver bus pins. These resistors limit the residual clamping current into the transceiver and prevent it from latching up.
8. While pure TVS protection is sufficient for surge transients up to 1 kV, higher transients require metal-oxide varistors (MOVs) which reduce the transients to a few hundred volts of clamping voltage, and transient blocking units (TBUs) that limit transient current to less than 1 mA.

10.2 Layout Example

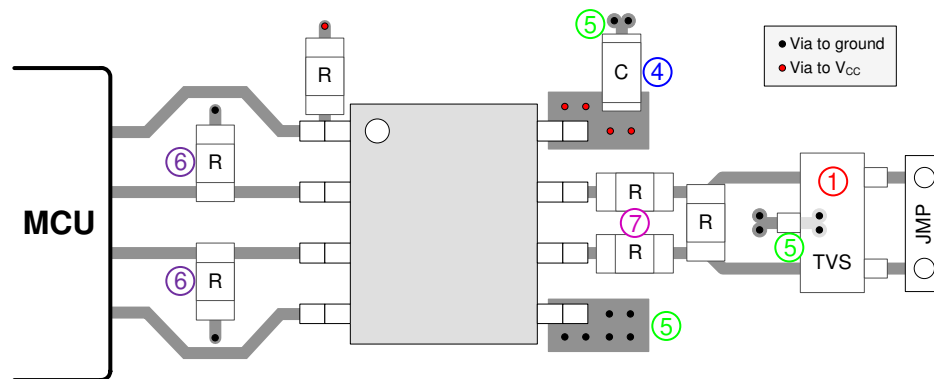

Figure 10-1. Layout Example for SOIC package

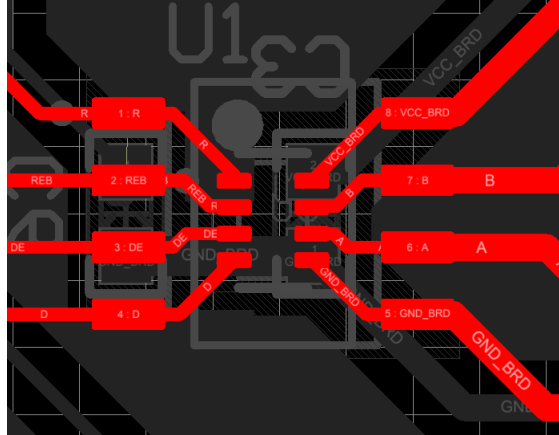

Figure 10-2. Layout Example for Co-layout of SOIC (D) and SOT (DRL)

11 Device and Documentation Support

11.1 Device Support

11.2 Receiving Notification of Documentation Updates

To receive notification of documentation updates, navigate to the device product folder on ti.com. Click on *Subscribe to updates* to register and receive a weekly digest of any product information that has changed. For change details, review the revision history included in any revised document.

11.3 Support Resources

[TI E2E™ support forums](#) are an engineer's go-to source for fast, verified answers and design help — straight from the experts. Search existing answers or ask your own question to get the quick design help you need.

Linked content is provided "AS IS" by the respective contributors. They do not constitute TI specifications and do not necessarily reflect TI's views; see TI's [Terms of Use](#).

11.4 Trademarks

TI E2E™ is a trademark of Texas Instruments.

All trademarks are the property of their respective owners.

11.5 Electrostatic Discharge Caution



This integrated circuit can be damaged by ESD. Texas Instruments recommends that all integrated circuits be handled with appropriate precautions. Failure to observe proper handling and installation procedures can cause damage.

ESD damage can range from subtle performance degradation to complete device failure. Precision integrated circuits may be more susceptible to damage because very small parametric changes could cause the device not to meet its published specifications.

11.6 Glossary

[TI Glossary](#) This glossary lists and explains terms, acronyms, and definitions.

12 Mechanical, Packaging, and Orderable Information

The following pages include mechanical, packaging, and orderable information. This information is the most current data available for the designated devices. This data is subject to change without notice and revision of this document. For browser-based versions of this data sheet, refer to the left-hand navigation.

PACKAGING INFORMATION

Orderable part number	Status (1)	Material type (2)	Package Pins	Package qty Carrier	RoHS (3)	Lead finish/ Ball material (4)	MSL rating/ Peak reflow (5)	Op temp (°C)	Part marking (6)
THVD1400DR	Active	Production	SOIC (D) 8	2500 LARGE T&R	Yes	NIPDAU	Level-1-260C-UNLIM	-40 to 125	1400
THVD1400DR.A	Active	Production	SOIC (D) 8	2500 LARGE T&R	Yes	NIPDAU	Level-1-260C-UNLIM	-40 to 125	1400
THVD1400DRG4	Active	Production	SOIC (D) 8	2500 LARGE T&R	Yes	NIPDAU	Level-1-260C-UNLIM	-40 to 125	1400
THVD1400DRG4.A	Active	Production	SOIC (D) 8	2500 LARGE T&R	Yes	NIPDAU	Level-1-260C-UNLIM	-40 to 125	1400
THVD1400DRLR	Active	Production	SOT-5X3 (DRL) 8	4000 LARGE T&R	Yes	Call TI Sn	Level-1-260C-UNLIM	-40 to 125	T400
THVD1400DRLR.A	Active	Production	SOT-5X3 (DRL) 8	4000 LARGE T&R	Yes	SN	Level-1-260C-UNLIM	-40 to 125	T400
THVD1420DR	Active	Production	SOIC (D) 8	2500 LARGE T&R	Yes	NIPDAU	Level-1-260C-UNLIM	-40 to 125	1420
THVD1420DR.A	Active	Production	SOIC (D) 8	2500 LARGE T&R	Yes	NIPDAU	Level-1-260C-UNLIM	-40 to 125	1420
THVD1420DRLR	Active	Production	SOT-5X3 (DRL) 8	4000 LARGE T&R	Yes	SN	Level-1-260C-UNLIM	-40 to 125	T420
THVD1420DRLR.A	Active	Production	SOT-5X3 (DRL) 8	4000 LARGE T&R	Yes	SN	Level-1-260C-UNLIM	-40 to 125	T420

(1) **Status:** For more details on status, see our [product life cycle](#).

(2) **Material type:** When designated, preproduction parts are prototypes/experimental devices, and are not yet approved or released for full production. Testing and final process, including without limitation quality assurance, reliability performance testing, and/or process qualification, may not yet be complete, and this item is subject to further changes or possible discontinuation. If available for ordering, purchases will be subject to an additional waiver at checkout, and are intended for early internal evaluation purposes only. These items are sold without warranties of any kind.

(3) **RoHS values:** Yes, No, RoHS Exempt. See the [TI RoHS Statement](#) for additional information and value definition.

(4) **Lead finish/Ball material:** Parts may have multiple material finish options. Finish options are separated by a vertical ruled line. Lead finish/Ball material values may wrap to two lines if the finish value exceeds the maximum column width.

(5) **MSL rating/Peak reflow:** The moisture sensitivity level ratings and peak solder (reflow) temperatures. In the event that a part has multiple moisture sensitivity ratings, only the lowest level per JEDEC standards is shown. Refer to the shipping label for the actual reflow temperature that will be used to mount the part to the printed circuit board.

(6) **Part marking:** There may be an additional marking, which relates to the logo, the lot trace code information, or the environmental category of the part.

Multiple part markings will be inside parentheses. Only one part marking contained in parentheses and separated by a "~" will appear on a part. If a line is indented then it is a continuation of the previous line and the two combined represent the entire part marking for that device.

Important Information and Disclaimer:The information provided on this page represents TI's knowledge and belief as of the date that it is provided. TI bases its knowledge and belief on information provided by third parties, and makes no representation or warranty as to the accuracy of such information. Efforts are underway to better integrate information from third parties. TI has taken and continues to take reasonable steps to provide representative

and accurate information but may not have conducted destructive testing or chemical analysis on incoming materials and chemicals. TI and TI suppliers consider certain information to be proprietary, and thus CAS numbers and other limited information may not be available for release.

In no event shall TI's liability arising out of such information exceed the total purchase price of the TI part(s) at issue in this document sold by TI to Customer on an annual basis.

TAPE AND REEL INFORMATION

QUADRANT ASSIGNMENTS FOR PIN 1 ORIENTATION IN TAPE



*All dimensions are nominal

Device	Package Type	Package Drawing	Pins	SPQ	Reel Diameter (mm)	Reel Width W1 (mm)	A0 (mm)	B0 (mm)	K0 (mm)	P1 (mm)	W (mm)	Pin1 Quadrant
THVD1400DR	SOIC	D	8	2500	330.0	12.4	6.4	5.2	2.1	8.0	12.0	Q1
THVD1400DRG4	SOIC	D	8	2500	330.0	12.4	6.4	5.2	2.1	8.0	12.0	Q1
THVD1400DRLR	SOT-5X3	DRL	8	4000	180.0	8.4	2.75	1.9	0.8	4.0	8.0	Q3
THVD1420DR	SOIC	D	8	2500	330.0	12.4	6.4	5.2	2.1	8.0	12.0	Q1
THVD1420DRLR	SOT-5X3	DRL	8	4000	180.0	8.4	2.75	1.9	0.8	4.0	8.0	Q3

TAPE AND REEL BOX DIMENSIONS

*All dimensions are nominal

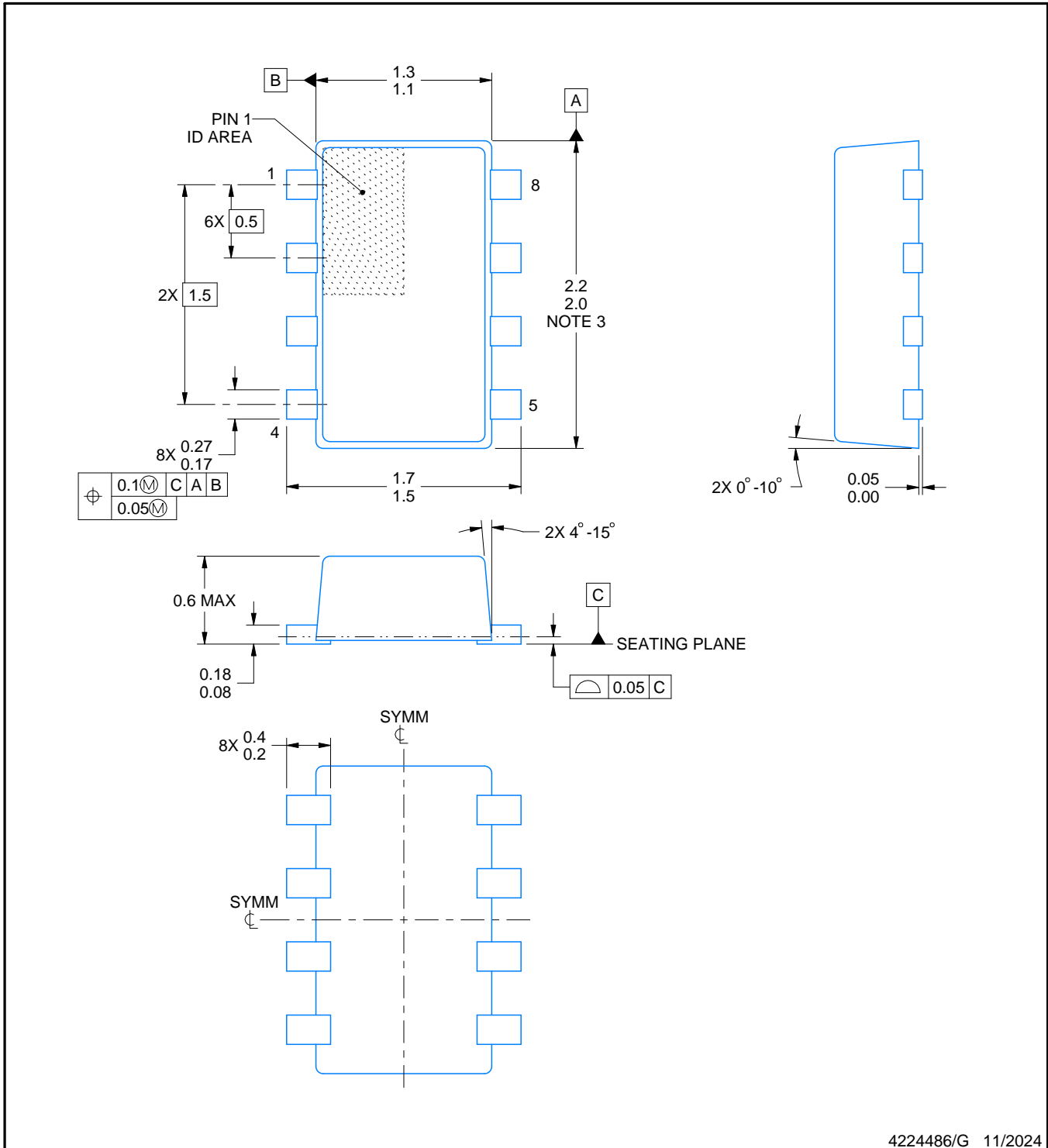
Device	Package Type	Package Drawing	Pins	SPQ	Length (mm)	Width (mm)	Height (mm)
THVD1400DR	SOIC	D	8	2500	353.0	353.0	32.0
THVD1400DRG4	SOIC	D	8	2500	353.0	353.0	32.0
THVD1400DRLR	SOT-5X3	DRL	8	4000	210.0	185.0	35.0
THVD1420DR	SOIC	D	8	2500	353.0	353.0	32.0
THVD1420DRLR	SOT-5X3	DRL	8	4000	210.0	185.0	35.0



4224486/G 11/2024

NOTES:

1. All linear dimensions are in millimeters. Any dimensions in parenthesis are for reference only. Dimensioning and tolerancing per ASME Y14.5M.
2. This drawing is subject to change without notice.
3. This dimension does not include mold flash, protrusions, or gate burrs. Mold flash, interlead flash, protrusions, or gate burrs shall not exceed 0.15 mm per side.
4. Reference JEDEC Registration MO-293, Variation UDAD

EXAMPLE BOARD LAYOUT

DRL0008A

SOT-5X3 - 0.6 mm max height

PLASTIC SMALL OUTLINE

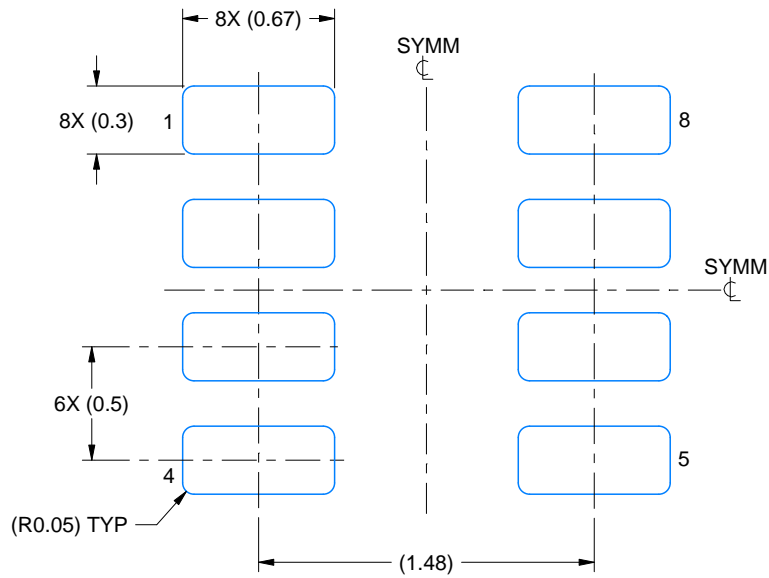

LAND PATTERN EXAMPLE
EXPOSED METAL SHOWN
SCALE:30X

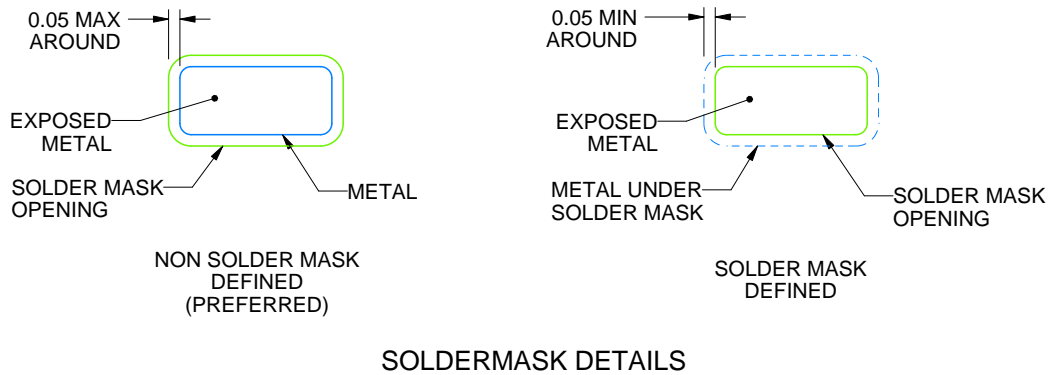

SOLDERMASK DETAILS

4224486/G 11/2024

NOTES: (continued)

5. Publication IPC-7351 may have alternate designs.
6. Solder mask tolerances between and around signal pads can vary based on board fabrication site.
7. Land pattern design aligns to IPC-610, Bottom Termination Component (BTC) solder joint inspection criteria.

EXAMPLE STENCIL DESIGN

DRL0008A

SOT-5X3 - 0.6 mm max height

PLASTIC SMALL OUTLINE

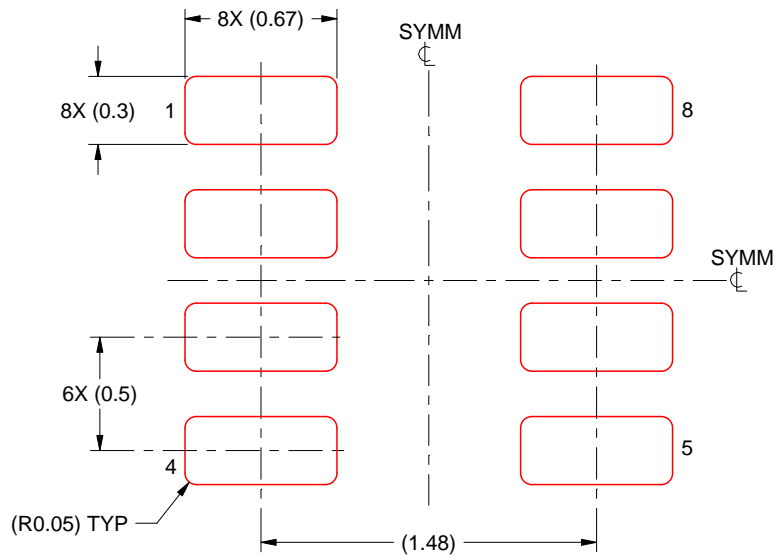

SOLDER PASTE EXAMPLE
BASED ON 0.1 mm THICK STENCIL
SCALE:30X

4224486/G 11/2024

NOTES: (continued)

8. Laser cutting apertures with trapezoidal walls and rounded corners may offer better paste release. IPC-7525 may have alternate design recommendations.
9. Board assembly site may have different recommendations for stencil design.



D0008A

PACKAGE OUTLINE

SOIC - 1.75 mm max height

SMALL OUTLINE INTEGRATED CIRCUIT



4214825/C 02/2019

NOTES:

1. Linear dimensions are in inches [millimeters]. Dimensions in parenthesis are for reference only. Controlling dimensions are in inches. Dimensioning and tolerancing per ASME Y14.5M.
2. This drawing is subject to change without notice.
3. This dimension does not include mold flash, protrusions, or gate burrs. Mold flash, protrusions, or gate burrs shall not exceed .006 [0.15] per side.
4. This dimension does not include interlead flash.
5. Reference JEDEC registration MS-012, variation AA.

EXAMPLE BOARD LAYOUT

D0008A

SOIC - 1.75 mm max height

SMALL OUTLINE INTEGRATED CIRCUIT



LAND PATTERN EXAMPLE
 EXPOSED METAL SHOWN
 SCALE:8X



SOLDER MASK DETAILS

4214825/C 02/2019

NOTES: (continued)

- 6. Publication IPC-7351 may have alternate designs.
- 7. Solder mask tolerances between and around signal pads can vary based on board fabrication site.

EXAMPLE STENCIL DESIGN

D0008A

SOIC - 1.75 mm max height

SMALL OUTLINE INTEGRATED CIRCUIT



SOLDER PASTE EXAMPLE
BASED ON .005 INCH [0.125 MM] THICK STENCIL
SCALE:8X

4214825/C 02/2019

NOTES: (continued)

8. Laser cutting apertures with trapezoidal walls and rounded corners may offer better paste release. IPC-7525 may have alternate design recommendations.
9. Board assembly site may have different recommendations for stencil design.

IMPORTANT NOTICE AND DISCLAIMER

TI PROVIDES TECHNICAL AND RELIABILITY DATA (INCLUDING DATASHEETS), DESIGN RESOURCES (INCLUDING REFERENCE DESIGNS), APPLICATION OR OTHER DESIGN ADVICE, WEB TOOLS, SAFETY INFORMATION, AND OTHER RESOURCES "AS IS" AND WITH ALL FAULTS, AND DISCLAIMS ALL WARRANTIES, EXPRESS AND IMPLIED, INCLUDING WITHOUT LIMITATION ANY IMPLIED WARRANTIES OF MERCHANTABILITY, FITNESS FOR A PARTICULAR PURPOSE OR NON-INFRINGEMENT OF THIRD PARTY INTELLECTUAL PROPERTY RIGHTS.

These resources are intended for skilled developers designing with TI products. You are solely responsible for (1) selecting the appropriate TI products for your application, (2) designing, validating and testing your application, and (3) ensuring your application meets applicable standards, and any other safety, security, regulatory or other requirements.

These resources are subject to change without notice. TI grants you permission to use these resources only for development of an application that uses the TI products described in the resource. Other reproduction and display of these resources is prohibited. No license is granted to any other TI intellectual property right or to any third party intellectual property right. TI disclaims responsibility for, and you fully indemnify TI and its representatives against any claims, damages, costs, losses, and liabilities arising out of your use of these resources.

TI's products are provided subject to [TI's Terms of Sale](#), [TI's General Quality Guidelines](#), or other applicable terms available either on [ti.com](#) or provided in conjunction with such TI products. TI's provision of these resources does not expand or otherwise alter TI's applicable warranties or warranty disclaimers for TI products. Unless TI explicitly designates a product as custom or customer-specified, TI products are standard, catalog, general purpose devices.

TI objects to and rejects any additional or different terms you may propose.

Copyright © 2025, Texas Instruments Incorporated

Last updated 10/2025