

TIBPAL16L8-15M, TIBPAL16R4-15M HIGH-PERFORMANCE IMPACT™ PAL® CIRCUITS

SRPS018B – D3338, JANUARY 1986 – REVISED NOVEMBER 2011

- **High-Performance Operation:**
Propagation Delay . . . 15 ns Max
- **Power-Up Clear on Registered Devices (All Register Outputs are Set High, but Voltage Levels at the Output Pins Go Low)**
- **Package Options Include Ceramic Flat (W) Packages, Ceramic Chip Carriers (FK), and Ceramic (J) 300-mil DIPs**
- **Dependable Texas Instruments Quality and Reliability**

DEVICE	I INPUTS	3-STATE O OUTPUTS	REGISTERED Q OUTPUTS	I/O PORTS
PAL16L8	10	2	0	6
PAL16R4	8	0	4 (3-state buffers)	4
PAL16R6	8	0	6 (3-state buffers)	2
PAL16R8	8	0	8 (3-state buffers)	0

description

These programmable array logic devices feature high speed and functional equivalency when compared with currently available devices. These IMPACT-X™ circuits combine the latest Advanced Low-Power Schottky technology with proven titanium-tungsten fuses to provide reliable, high-performance substitutes for conventional TTL logic. Their easy programmability allows for quick design of custom functions and typically results in a more compact circuit board. In addition, chip carriers are available for further reduction in board space.

The TIBPAL16' M series is characterized for operation over the full military temperature range of -55°C to 125°C.

IMPORTANT PROGRAMMING NOTE: For TIBPAL16L8-15M devices in J, W, or FK packages – For date code 9903A or later device programming, select from either **TI Military/16L8-12** or TI commercial **TI/16L8-10** on the Manufacturer/Device menu listing in your programming system.

IMPORTANT PROGRAMMING NOTE: For TIBPAL16R4-15M devices in J, W, or FK packages – For date code 9616A or later device programming, select from either **TI Military/16R4-12** or TI commercial **TI/16R4-10** on the Manufacturer/Device menu listing in your programming system.

TIBPAL16L8'
J OR W PACKAGE
(TOP VIEW)

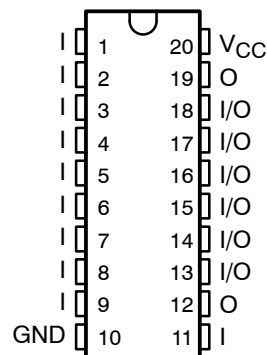

TIBPAL16L8'
FK PACKAGE
(TOP VIEW)

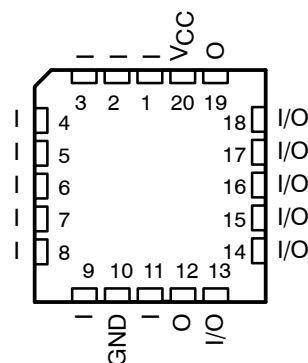

Pin assignments in operating mode



Please be aware that an important notice concerning availability, standard warranty, and use in critical applications of Texas Instruments semiconductor products and disclaimers thereto appears at the end of this data sheet.

IMPACT is a trademark of Texas Instruments Incorporated.
PAL is a registered trademark of Advanced Micro Devices Inc.

PRODUCTION DATA information is current as of publication date. Products conform to specifications per the terms of Texas Instruments standard warranty. Production processing does not necessarily include testing of all parameters.



POST OFFICE BOX 655303 • DALLAS, TEXAS 75265

Copyright © 1996 – 2011, Texas Instruments Incorporated

TIBPAL16L8-15M, TIBPAL16R4-15M HIGH-PERFORMANCE *IMPACT*™ PAL® CIRCUITS

SRPS018B – D3338, JANUARY 1986 – REVISED NOVEMBER 2011

TIBPAL16R4'
J OR W PACKAGE
(TOP VIEW)

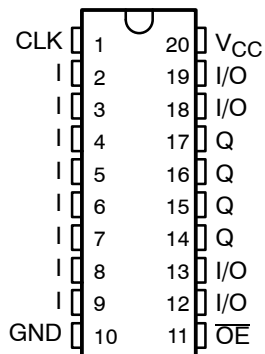

TIBPAL16R4'
FK PACKAGE
(TOP VIEW)

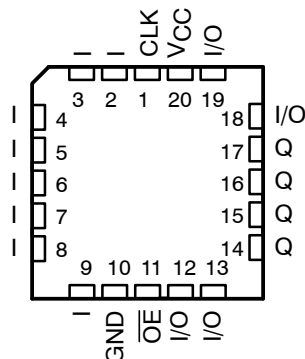

TIBPAL16R6'
J OR W PACKAGE
(TOP VIEW)

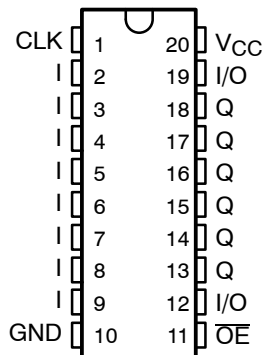

TIBPAL16R6'
FK PACKAGE
(TOP VIEW)

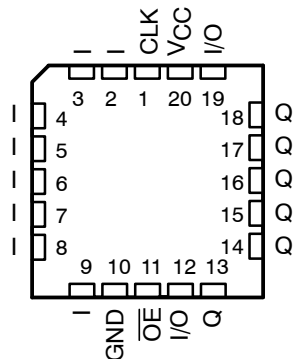

TIBPAL16R8'
J OR W PACKAGE
(TOP VIEW)

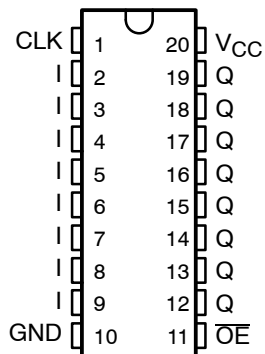

TIBPAL16R8'
FK PACKAGE
(TOP VIEW)

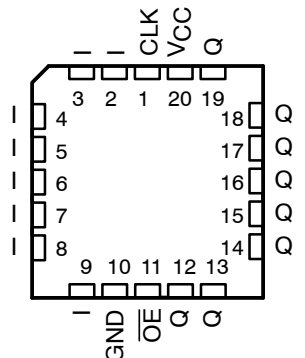

Pin assignments in operating mode

functional block diagrams (positive logic)

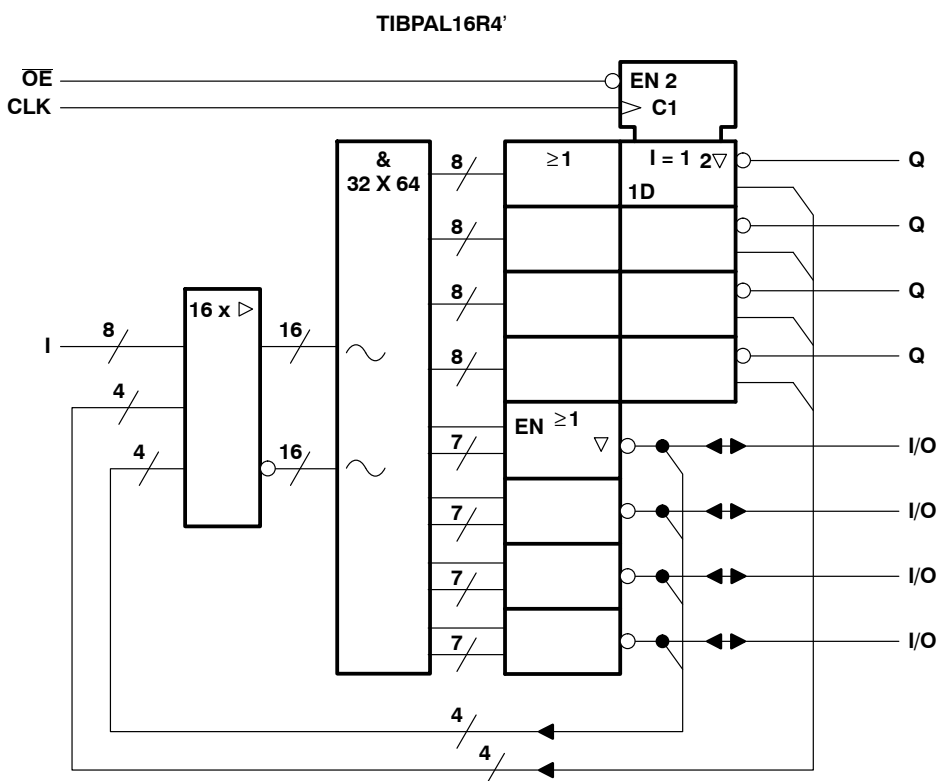
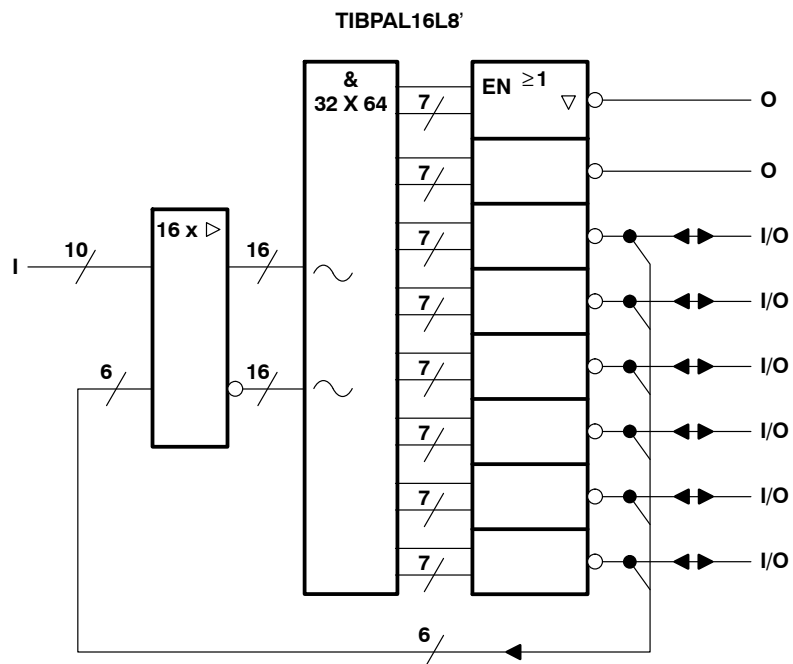

~ denotes fused inputs

TIBPAL16L8-15M, TIBPAL16R4-15M HIGH-PERFORMANCE *IMPACT*™ PAL® CIRCUITS

SRPS018B – D3338, JANUARY 1986 – REVISED NOVEMBER 2011

functional block diagrams (positive logic)

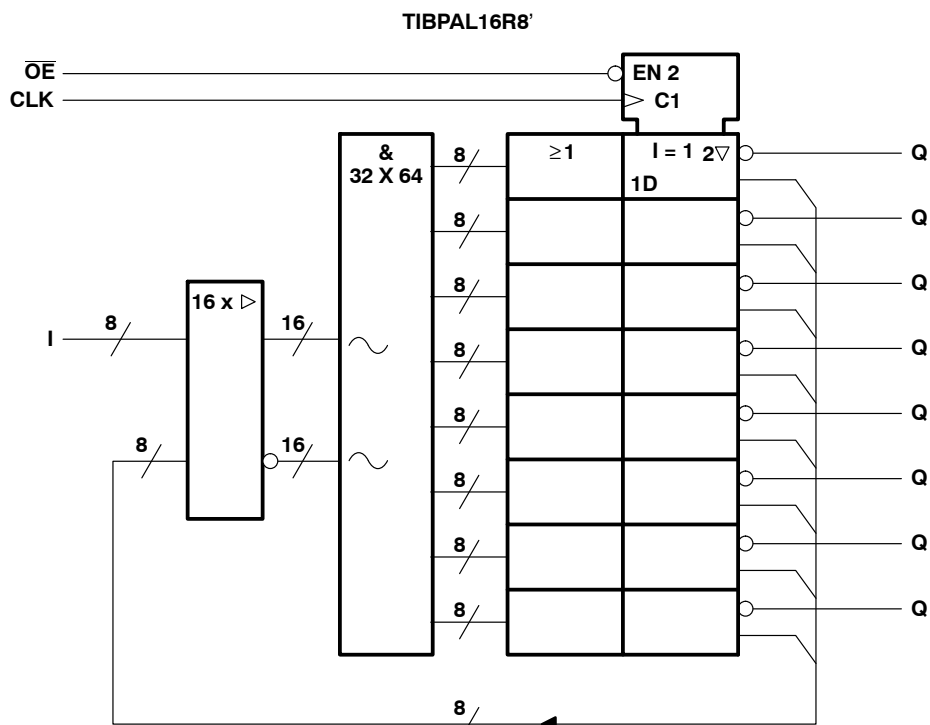
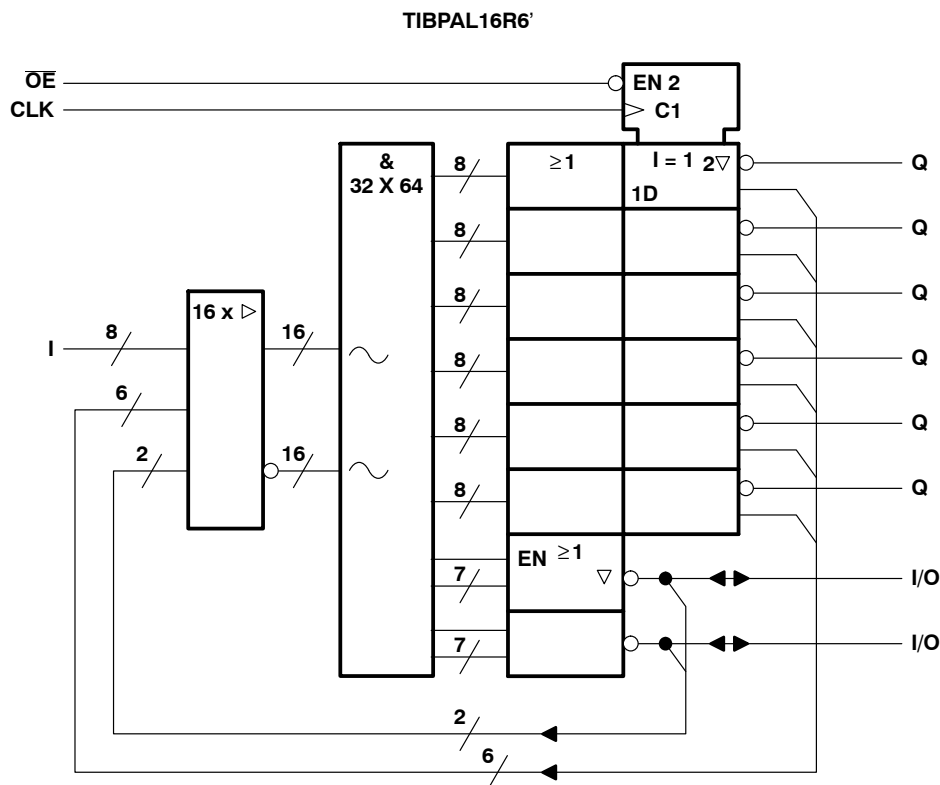

~ denotes fused inputs

TIBPAL16L8-15M, TIBPAL16R4-15M HIGH-PERFORMANCE *IMPACT*™ PAL® CIRCUITS

SRPS018B – D3338, JANUARY 1986 – REVISED NOVEMBER 2011

TIBPAL16L8-15M logic diagram (positive logic)

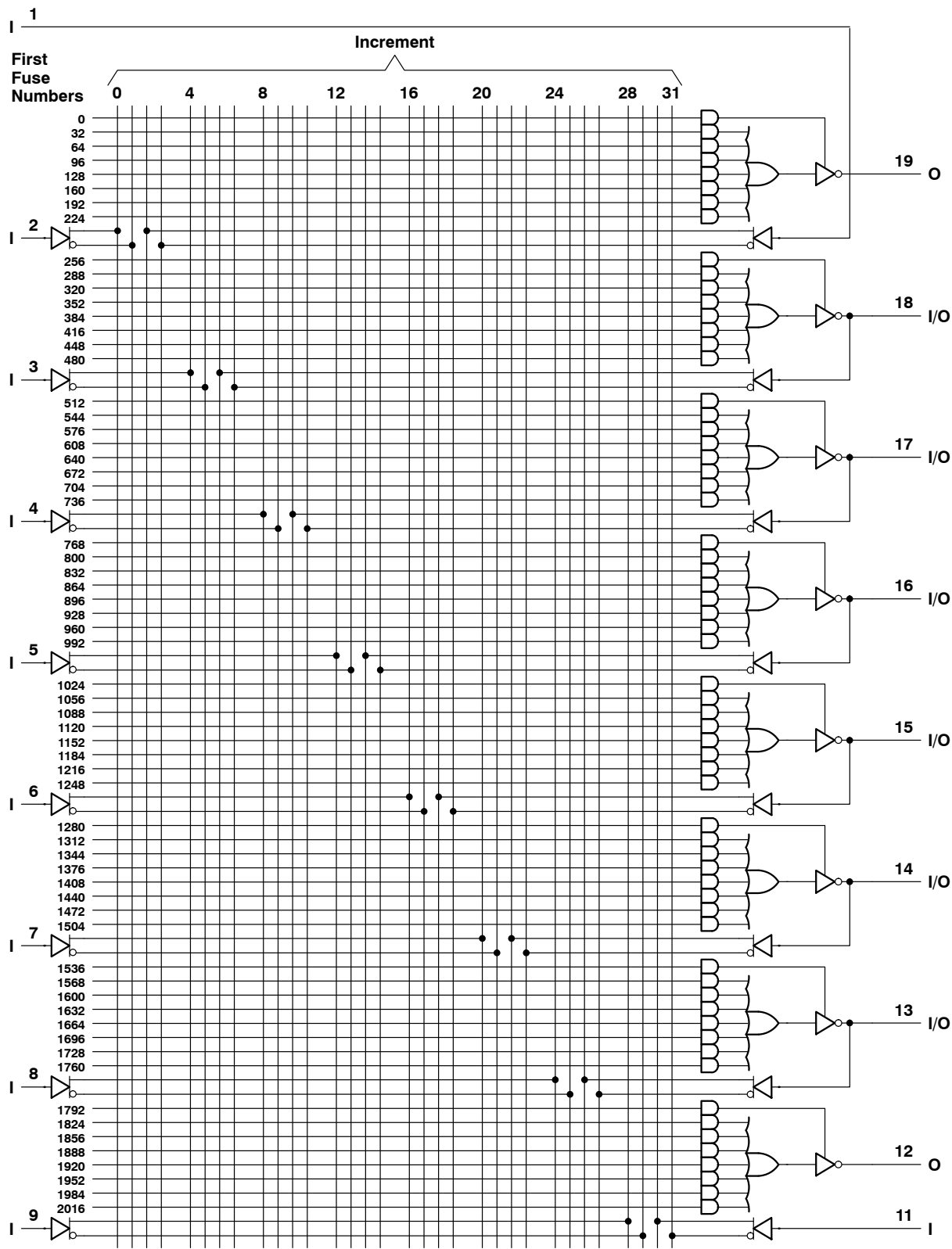

Fuse number = First fuse number + Increment



TIBPAL16L8-15M, TIBPAL16R4-15M HIGH-PERFORMANCE *IMPACT*™ PAL® CIRCUITS

SRPS018B - D3338, JANUARY 1986 - REVISED NOVEMBER 2011

TIBPAL16R4-15M logic diagram (positive logic)

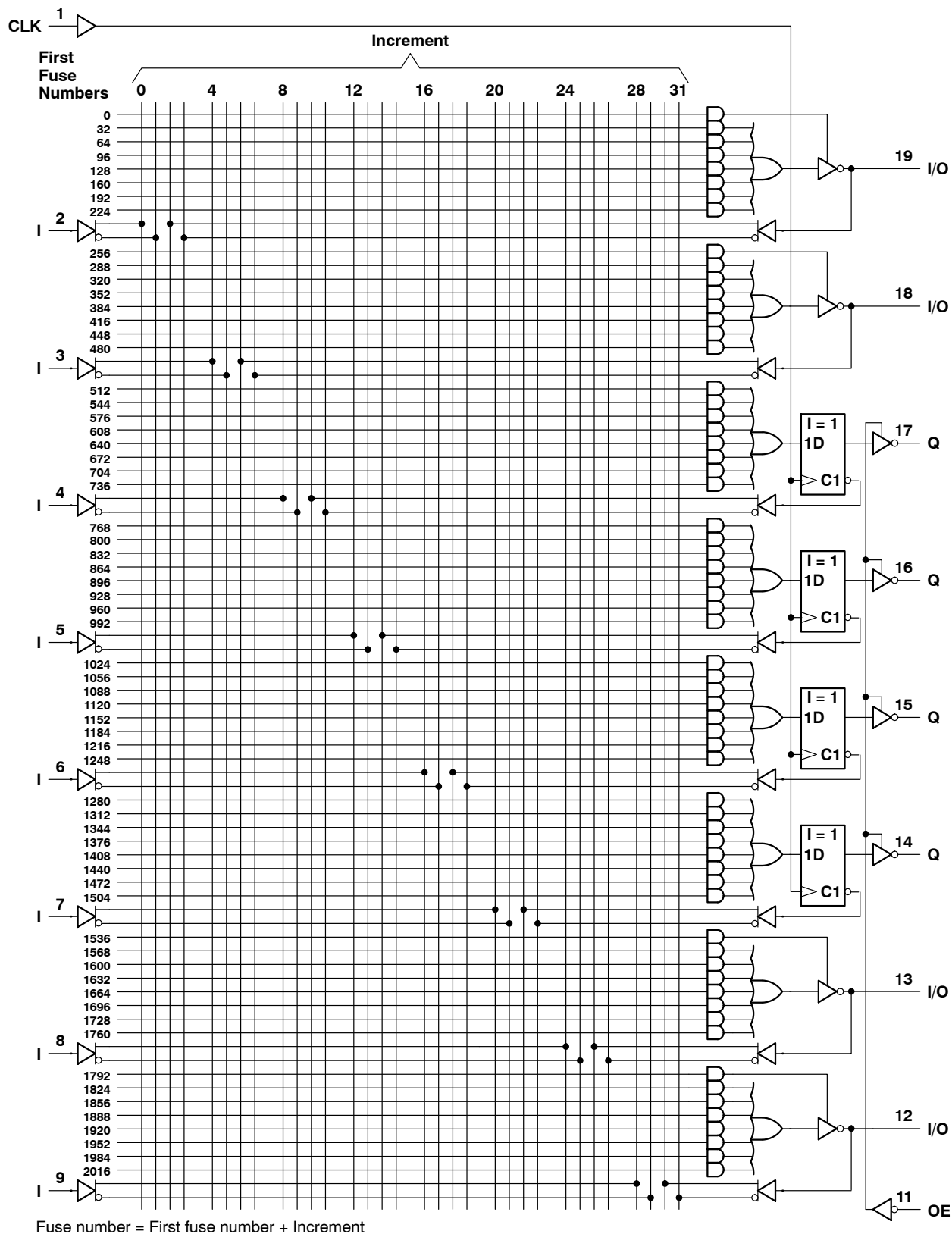

TIBPAL16R6-15M logic diagram (positive logic)

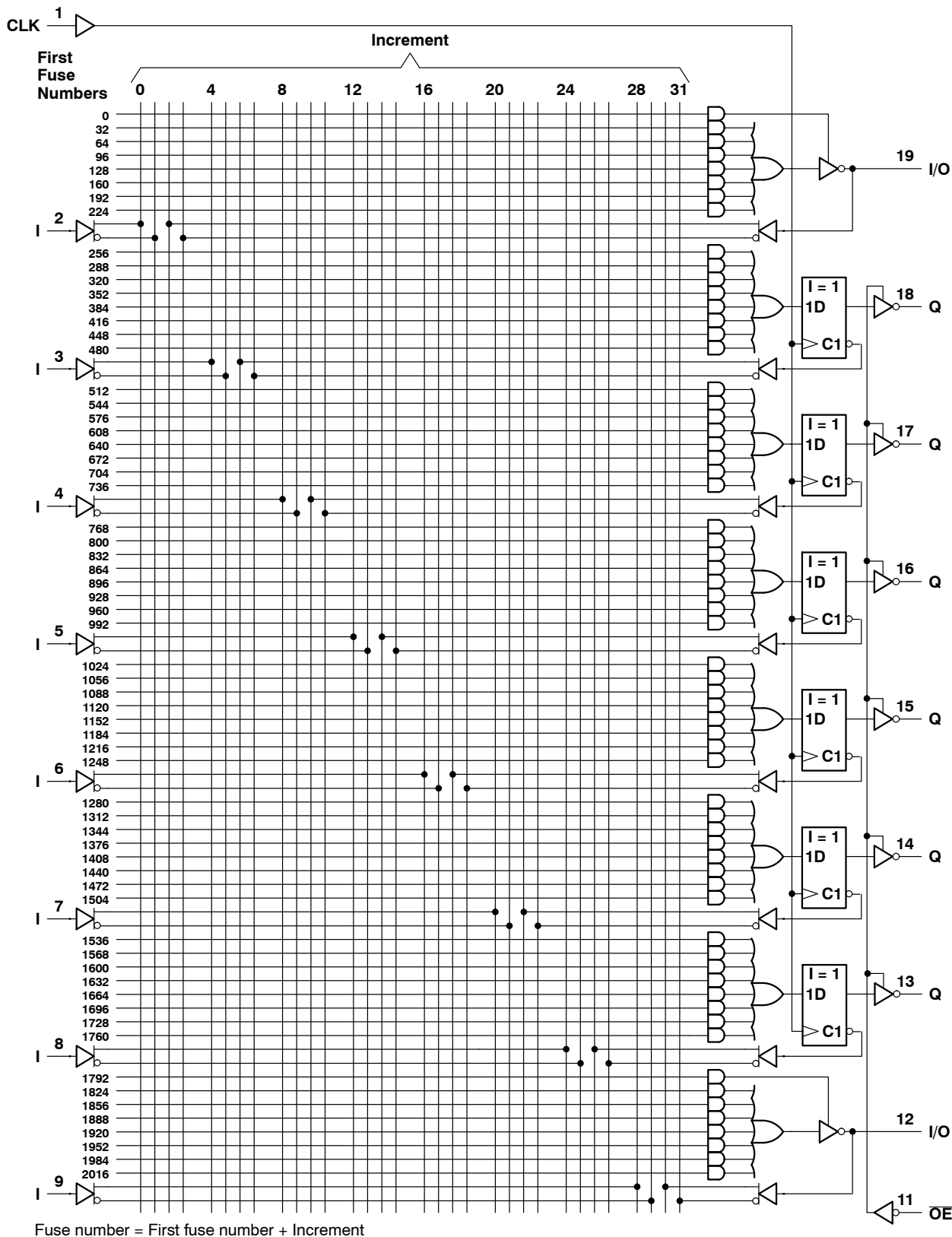

TIBPAL16L8-15M, TIBPAL16R4-15M HIGH-PERFORMANCE *IMPACT*™ PAL® CIRCUITS

SRPS018B - D3338, JANUARY 1986 - REVISED NOVEMBER 2011

TIBPAL16R8-15M logic diagram (positive logic)

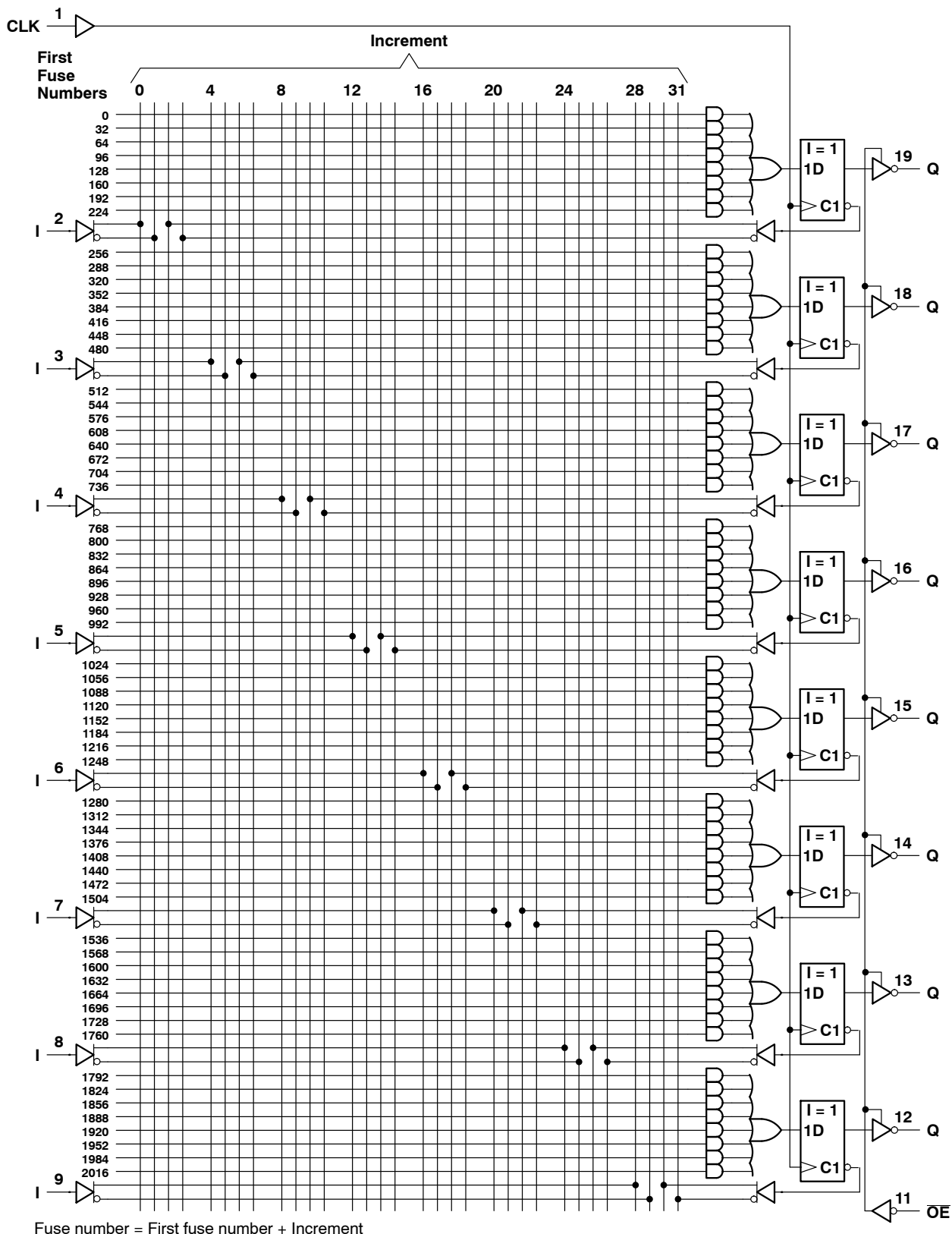

Fuse number = First fuse number + Increment



TIBPAL16L8-15M, TIBPAL16R4-15M HIGH-PERFORMANCE IMPACT™ PAL® CIRCUITS

SRPS018B – D3338, JANUARY 1986 – REVISED NOVEMBER 2011

absolute maximum ratings over operating free-air temperature range (unless otherwise noted)†

Supply voltage, V_{CC} (see Note 1)	7 V
Input voltage (see Note 1)	5.5 V
Voltage applied to disabled output (see Note 1)	5.5 V
Operating free-air temperature range	-55°C to 125°C
Storage temperature range	-65°C to 150°C

† Stresses beyond those listed under “absolute maximum ratings” may cause permanent damage to the device. These are stress ratings only, and functional operation of the device at these or any other conditions beyond those indicated under “recommended operating conditions” is not implied. Exposure to absolute-maximum-rated conditions for extended periods may affect device reliability.

NOTE 1: These ratings apply except for programming pins during a programming cycle.

recommended operating conditions

		MIN	NOM	MAX	UNIT
V_{CC}	Supply voltage	4.5	5	5.5	V
V_{IH}	High-level input voltage	2		5.5	V
V_{IL}	Low-level input voltage			0.8	V
I_{OH}	High-level output current			-2	mA
I_{OL}	Low-level output current			12	mA
f_{clock}	Clock frequency	0		50	MHz
t_w	Pulse duration, clock (see Note 2)	High		9	ns
		Low		10	
t_{su}	Setup time, input or feedback before clock↑	15			ns
t_h	Hold time, input or feedback after clock↑	0			ns
T_A	Operating free-air temperature	-55	25	125	°C

NOTE 2: The total clock period of clock high and clock low must not exceed clock frequency, f_{clock} . The minimum pulse durations specified are only for clock high or low, but not for both simultaneously.

electrical characteristics over recommended operating free-air temperature range

PARAMETER	TEST CONDITIONS	TIBPAL16R4-15M			UNIT
		MIN	TYP‡	MAX	
V_{IK}	$V_{CC} = 4.5$ V, $I_I = -18$ mA			-1.5	V
V_{OH}	$V_{CC} = 4.5$ V, $I_{OH} = -2$ mA	2.4	3.3		V
V_{OL}	$V_{CC} = 4.5$ V, $I_{OL} = 12$ mA		0.35	0.5	V
I_{OZH}	Outputs			20	μ A
	I/O ports	$V_{CC} = 5.5$ V, $V_O = 2.7$ V		100	
I_{OZL}	Outputs			-20	μ A
	I/O ports	$V_{CC} = 5.5$ V, $V_O = 0.4$ V		-250	
I_I	Pin 1, 11			0.2	mA
	All others	$V_{CC} = 5.5$ V, $V_I = 5.5$ V		0.1	
I_{IH}	Pin 1, 11			50	μ A
	I/O ports	$V_{CC} = 5.5$ V, $V_I = 2.7$ V		100	
	All others			25	
I_{IL}	$V_{CC} = 5.5$ V, $V_I = 0.4$ V			-0.25	mA
I_{OS}^{\S}	$V_{CC} = 5.5$ V, $V_O = 0.5$ V	-30		-250	mA
I_{CC}	$V_{CC} = 5.5$ V, $V_I = 0$, Outputs open		170	220	mA

‡ All typical values are at $V_{CC} = 5$ V, $T_A = 25^\circ$ C.

§ Not more than one output should be shorted at a time and the duration of the short circuit should not exceed one second. Set V_O at 0.5 V to avoid test equipment degradation.



TIBPAL16L8-15M, TIBPAL16R4-15M HIGH-PERFORMANCE *IMPACT*™ *PAL*® CIRCUITS

SRPS018B – D3338, JANUARY 1986 – REVISED NOVEMBER 2011

electrical characteristics over recommended operating free-air temperature range

PARAMETER	TEST CONDITIONS		TIBPAL16L8-15M TIBPAL16R6-15M TIBPAL16R8-15M			UNIT
			MIN	TYP†	MAX	
V_{IK}	$V_{CC} = 4.5\text{ V}$,	$I_I = -18\text{ mA}$			-1.5	V
V_{OH}	$V_{CC} = 4.5\text{ V}$,	$I_{OH} = -2\text{ mA}$	2.4	3.3		V
V_{OL}	$V_{CC} = 4.5\text{ V}$,	$I_{OL} = 12\text{ mA}$	0.35	0.5		V
I_{OZH}	Outputs	$V_{CC} = 5.5\text{ V}$, $V_O = 2.7\text{ V}$	20			μA
	I/O ports		100			
I_{OZL}	Outputs	$V_{CC} = 5.5\text{ V}$, $V_O = 0.4\text{ V}$	-20			μA
	I/O ports		-250			
I_I	Pin 1, 11	$V_{CC} = 5.5\text{ V}$, $V_I = 5.5\text{ V}$	0.2			mA
	All others		0.1			
I_{IH}	Pin 1, 11	$V_{CC} = 5.5\text{ V}$, $V_I = 2.7\text{ V}$	50			μA
	I/O ports		100			
	All others		20			
I_{IL}	I/O ports	$V_{CC} = 5.5\text{ V}$, $V_I = 0.4\text{ V}$	-0.25			mA
	All others		-0.2			
I_{OS}^\ddagger	$V_{CC} = 5.5\text{ V}$,	$V_O = 0.5\text{ V}$	-30		-250	mA
I_{CC}	$V_{CC} = 5.5\text{ V}$,	$V_I = 0$, Outputs open	170		220	mA

† All typical values are at $V_{CC} = 5\text{ V}$, $T_A = 25^\circ\text{C}$.‡ Not more than one output should be shorted at a time and the duration of the short circuit should not exceed one second. Set V_O at 0.5 V to avoid test equipment degradation.

switching characteristics over recommended ranges of supply voltage and operating free-air temperature (unless otherwise noted)

PARAMETER	FROM (INPUT)	TO (OUTPUT)	TEST CONDITIONS	MIN	TYP†	MAX	UNIT
f_{max}^\S			R1 = 390 Ω , R2 = 750 Ω , See Figure 1	50			MHz
t_{pd}	I, I/O	O, I/O		8	15		ns
t_{pd}	CLK↑	Q		7	12		ns
t_{en}	OE↓	Q		8	12		ns
t_{dis}	OE↑	Q		7	12		ns
t_{en}	I, I/O	O, I/O		8	15		ns
t_{dis}	I, I/O	O, I/O		8	15		ns

† All typical values are at $V_{CC} = 5\text{ V}$, $T_A = 25^\circ\text{C}$.

§ Maximum operating frequency and propagation delay are specified for the basic building block. When using feedback, limits must be calculated accordingly.

programming information

Texas Instruments programmable logic devices can be programmed using widely available software and inexpensive device programmers.

The TIBPAL16R4-15M with date codes prior to 9616A must be programmed according to programming algorithms/specifications corresponding to the TIBPAL16R4-12C. The TIBPAL16R4-15M with date code 9616A or newer must be programmed according to programming algorithms/specifications corresponding to the TIBPAL16R4-10C.

Regardless of date code, the TIBPAL16L8-15M, TIBPAL16R6-15M, and TIBPAL16R8-15M must be programmed according to programming algorithms/specifications corresponding to the TIBPAL16L8-12C, TIBPAL16R6-12C, and TIBPAL16R8-12C, respectively. Failure to do so may damage the devices.

Complete programming specifications, algorithms, and the latest information on hardware, software, and firmware are available upon request. Information on programmers capable of programming Texas Instruments programmable logic is also available, upon request, from the nearest TI field sales office, local authorized TI distributor, or by calling Texas Instruments at (214) 997-5666.

**Table 1. Programming Reference Table
(see Note 3)**

DEVICE	DESC SMD NUMBER	FAMILY/PINOUT CODE
TIBPAL16L8-15MJB	5962-8515509RA	9A/17
TIBPAL16L8-15MFKB	5962-85155092A	9A/717
TIBPAL16L8-15MWB	5962-8515509SA	9A/17
TIBPAL16R4-15MJB	5962-8515512RA	A1/24
TIBPAL16R4-15MFKB	5962-85155122A	0A1/724
TIBPAL16R4-15MWB	5962-8515512SA	A1/24
TIBPAL16R6-15MJB	5962-8515511RA	9A/24
TIBPAL16R6-15MFKB	5962-85155112A	9A/724
TIBPAL16R6-15MWB	5962-8515511SA	9A/24
TIBPAL16R8-15MJB	5962-8515510RA	9A/24
TIBPAL16R8-15MFKB	5962-85155102A	9A/724
TIBPAL16R8-15MWB	5962-8515510SA	9A/24

NOTE 3: Programming information for TIBPAL16R4-15M with date codes 9616A or newer. Programming information for TIBPAL16L8-15M, TIBPAL16R6-15M, and TIBPAL16R8-15M regardless of date code.

TIBPAL16L8-15M, TIBPAL16R4-15M HIGH-PERFORMANCE *IMPACT*™ PAL® CIRCUITS

SRPS018B – D3338, JANUARY 1986 – REVISED NOVEMBER 2011

PARAMETER MEASUREMENT INFORMATION

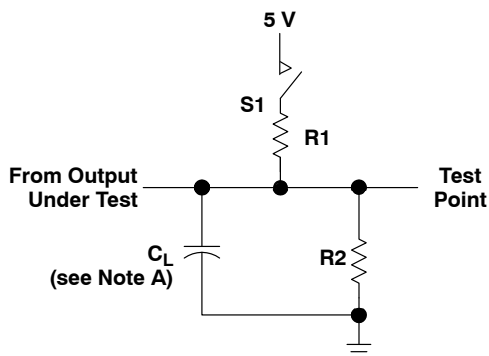

LOAD CIRCUIT FOR
3-STATE OUTPUTS

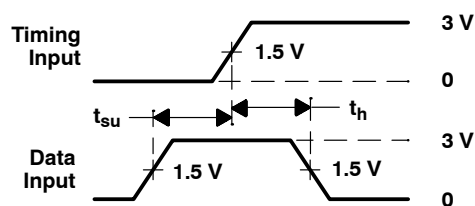

VOLTAGE WAVEFORMS
SETUP AND HOLD TIMES

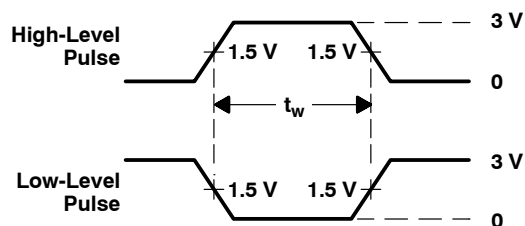

VOLTAGE WAVEFORMS
PULSE DURATIONS

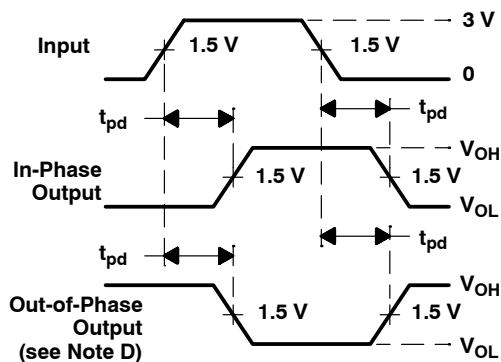

VOLTAGE WAVEFORMS
PROPAGATION DELAY TIMES

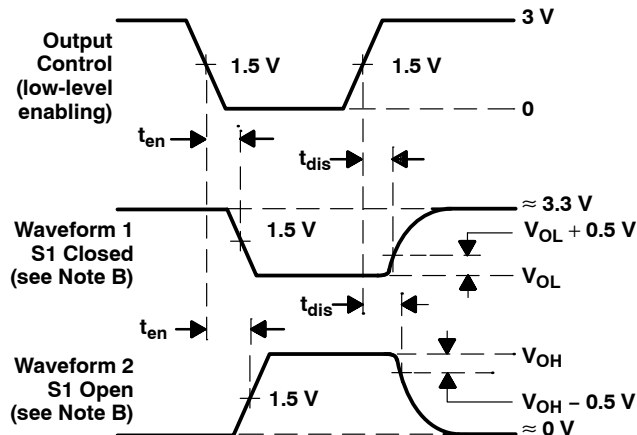

VOLTAGE WAVEFORMS
ENABLE AND DISABLE TIMES, 3-STATE OUTPUTS

- NOTES: A. C_L includes probe and jig capacitance and is 50 pF for t_{pd} and t_{en} , 5 pF for t_{dis} .
- B. Waveform 1 is for an output with internal conditions such that the output is low except when disabled by the output control. Waveform 2 is for an output with internal conditions such that the output is high except when disabled by the output control.
- C. All input pulses have the following characteristics: $PRR \leq 10$ MHz, t_r and $t_f \leq 2$ ns, duty cycle = 50%.
- D. When measuring propagation delay times of 3-state outputs, switch S1 is closed.
- E. Equivalent loads may be used for testing.

Figure 1. Load Circuit and Voltage Waveforms

PACKAGING INFORMATION

Orderable part number	Status (1)	Material type (2)	Package Pins	Package qty Carrier	RoHS (3)	Lead finish/ Ball material (4)	MSL rating/ Peak reflow (5)	Op temp (°C)	Part marking (6)
5962-85155122A	NRND	Production	LCCC (FK) 20	55 TUBE	No	SNPB	N/A for Pkg Type	-55 to 125	5962- 85155122A TIBPAL16 R4-15MFKB
5962-8515512RA	NRND	Production	CDIP (J) 20	20 TUBE	No	SNPB	N/A for Pkg Type	-55 to 125	5962-8515512RA TIBPAL16R4-15M JB
5962-8515512SA	NRND	Production	CFP (W) 20	25 TUBE	No	SNPB	N/A for Pkg Type	-55 to 125	5962-8515512SA TIBPAL16R4-15M WB
TIBPAL16L8-15MJ	Last Time Buy	Production	CDIP (J) 20	20 TUBE	No	SNPB	N/A for Pkg Type	-55 to 125	TIBPAL16L8-15M J
TIBPAL16L8-15MJ.A	Last Time Buy	Production	CDIP (J) 20	20 TUBE	No	SNPB	N/A for Pkg Type	-55 to 125	TIBPAL16L8-15M J
TIBPAL16R4-15MFKB	NRND	Production	LCCC (FK) 20	55 TUBE	No	SNPB	N/A for Pkg Type	-55 to 125	5962- 85155122A TIBPAL16 R4-15MFKB
TIBPAL16R4-15MFKB.A	NRND	Production	LCCC (FK) 20	55 TUBE	No	SNPB	N/A for Pkg Type	-55 to 125	5962- 85155122A TIBPAL16 R4-15MFKB
TIBPAL16R4-15MJB	NRND	Production	CDIP (J) 20	20 TUBE	No	SNPB	N/A for Pkg Type	-55 to 125	5962-8515512RA TIBPAL16R4-15M JB
TIBPAL16R4-15MJB.A	NRND	Production	CDIP (J) 20	20 TUBE	No	SNPB	N/A for Pkg Type	-55 to 125	5962-8515512RA TIBPAL16R4-15M JB
TIBPAL16R4-15MWB	NRND	Production	CFP (W) 20	25 TUBE	No	SNPB	N/A for Pkg Type	-55 to 125	5962-8515512SA TIBPAL16R4-15M WB
TIBPAL16R4-15MWB.A	NRND	Production	CFP (W) 20	25 TUBE	No	SNPB	N/A for Pkg Type	-55 to 125	5962-8515512SA TIBPAL16R4-15M WB

(1) **Status:** For more details on status, see our [product life cycle](#).

(2) **Material type:** When designated, preproduction parts are prototypes/experimental devices, and are not yet approved or released for full production. Testing and final process, including without limitation quality assurance, reliability performance testing, and/or process qualification, may not yet be complete, and this item is subject to further changes or possible discontinuation. If available for ordering, purchases will be subject to an additional waiver at checkout, and are intended for early internal evaluation purposes only. These items are sold without warranties of any kind.

(3) **RoHS values:** Yes, No, RoHS Exempt. See the [TI RoHS Statement](#) for additional information and value definition.

(4) **Lead finish/Ball material:** Parts may have multiple material finish options. Finish options are separated by a vertical ruled line. Lead finish/Ball material values may wrap to two lines if the finish value exceeds the maximum column width.

(5) **MSL rating/Peak reflow:** The moisture sensitivity level ratings and peak solder (reflow) temperatures. In the event that a part has multiple moisture sensitivity ratings, only the lowest level per JEDEC standards is shown. Refer to the shipping label for the actual reflow temperature that will be used to mount the part to the printed circuit board.

(6) **Part marking:** There may be an additional marking, which relates to the logo, the lot trace code information, or the environmental category of the part.

Multiple part markings will be inside parentheses. Only one part marking contained in parentheses and separated by a "-" will appear on a part. If a line is indented then it is a continuation of the previous line and the two combined represent the entire part marking for that device.

Important Information and Disclaimer: The information provided on this page represents TI's knowledge and belief as of the date that it is provided. TI bases its knowledge and belief on information provided by third parties, and makes no representation or warranty as to the accuracy of such information. Efforts are underway to better integrate information from third parties. TI has taken and continues to take reasonable steps to provide representative and accurate information but may not have conducted destructive testing or chemical analysis on incoming materials and chemicals. TI and TI suppliers consider certain information to be proprietary, and thus CAS numbers and other limited information may not be available for release.

In no event shall TI's liability arising out of such information exceed the total purchase price of the TI part(s) at issue in this document sold by TI to Customer on an annual basis.

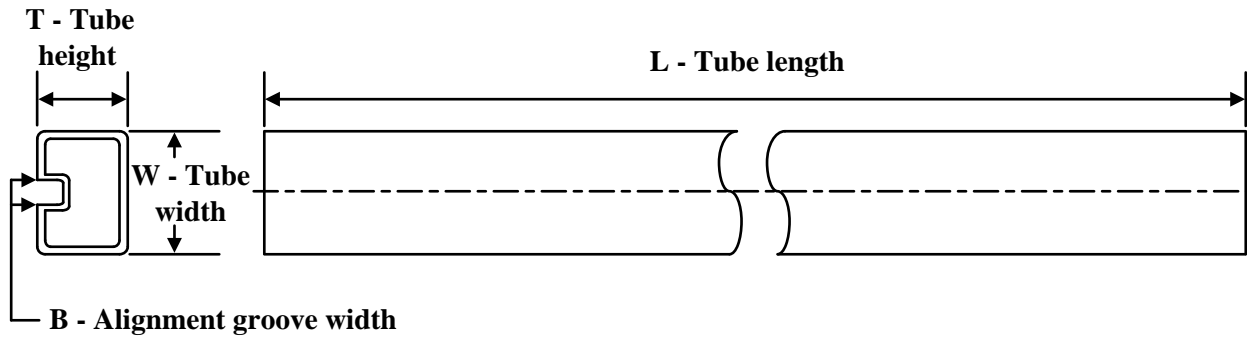
TUBE

*All dimensions are nominal

Device	Package Name	Package Type	Pins	SPQ	L (mm)	W (mm)	T (μm)	B (mm)
5962-85155122A	FK	LCCC	20	55	506.98	12.06	2030	NA
5962-8515512SA	W	CFP	20	25	506.98	26.16	6220	NA
TIBPAL16R4-15MFKB	FK	LCCC	20	55	506.98	12.06	2030	NA
TIBPAL16R4-15MFKB.A	FK	LCCC	20	55	506.98	12.06	2030	NA
TIBPAL16R4-15MWB	W	CFP	20	25	506.98	26.16	6220	NA
TIBPAL16R4-15MWB.A	W	CFP	20	25	506.98	26.16	6220	NA

J (R-GDIP-T**)

14 LEADS SHOWN

CERAMIC DUAL IN-LINE PACKAGE

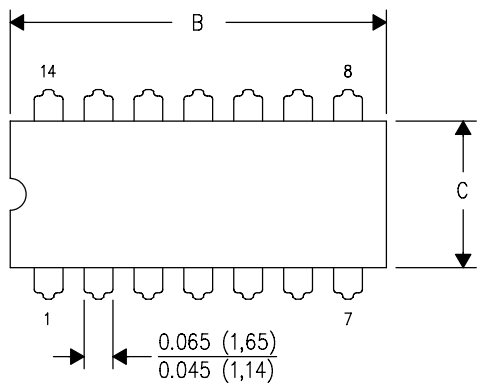

DIM \ PINS **	14	16	18	20
A	0.300 (7,62) BSC	0.300 (7,62) BSC	0.300 (7,62) BSC	0.300 (7,62) BSC
B MAX	0.785 (19,94)	.840 (21,34)	0.960 (24,38)	1.060 (26,92)
B MIN	—	—	—	—
C MAX	0.300 (7,62)	0.300 (7,62)	0.310 (7,87)	0.300 (7,62)
C MIN	0.245 (6,22)	0.245 (6,22)	0.220 (5,59)	0.245 (6,22)

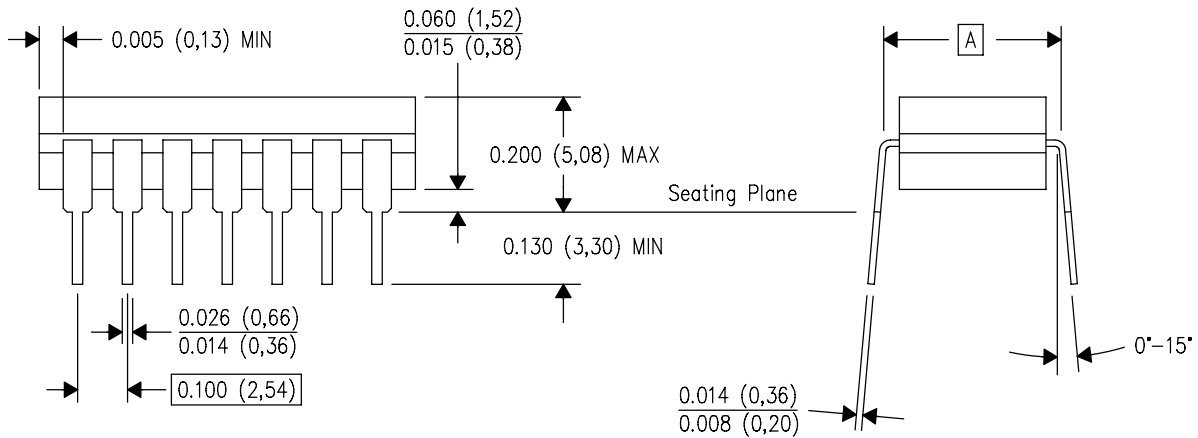

4040083/F 03/03

- NOTES:
- All linear dimensions are in inches (millimeters).
 - This drawing is subject to change without notice.
 - This package is hermetically sealed with a ceramic lid using glass frit.
 - Index point is provided on cap for terminal identification only on press ceramic glass frit seal only.
 - Falls within MIL STD 1835 GDIP1-T14, GDIP1-T16, GDIP1-T18 and GDIP1-T20.

GENERIC PACKAGE VIEW

FK 20

LCCC - 2.03 mm max height

8.89 x 8.89, 1.27 mm pitch

LEADLESS CERAMIC CHIP CARRIER

This image is a representation of the package family, actual package may vary.
Refer to the product data sheet for package details.

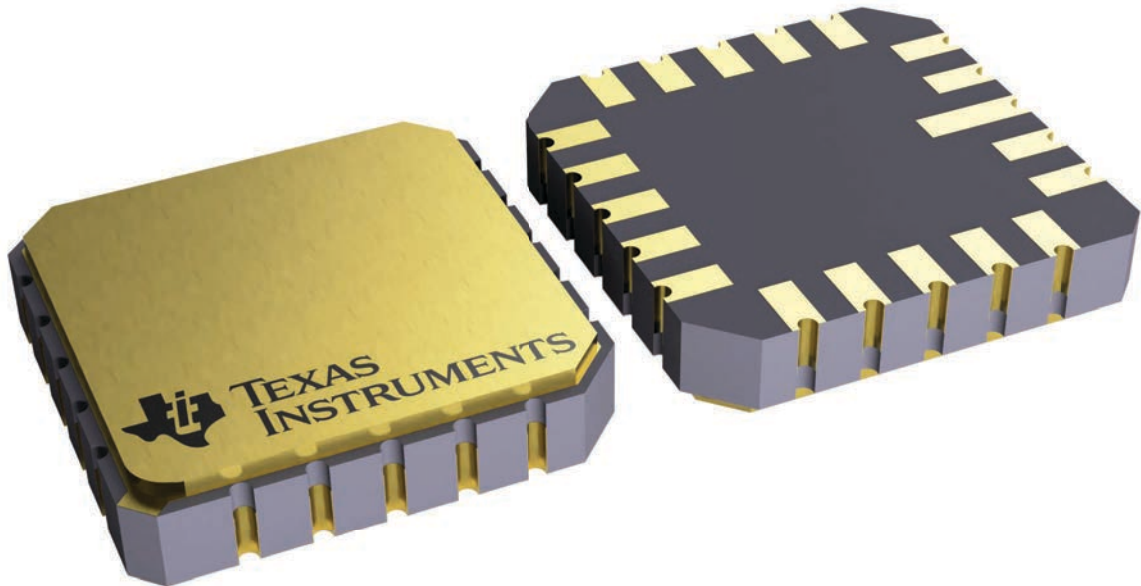

4229370VA\

W (R-GDFP-F20)

CERAMIC DUAL FLATPACK

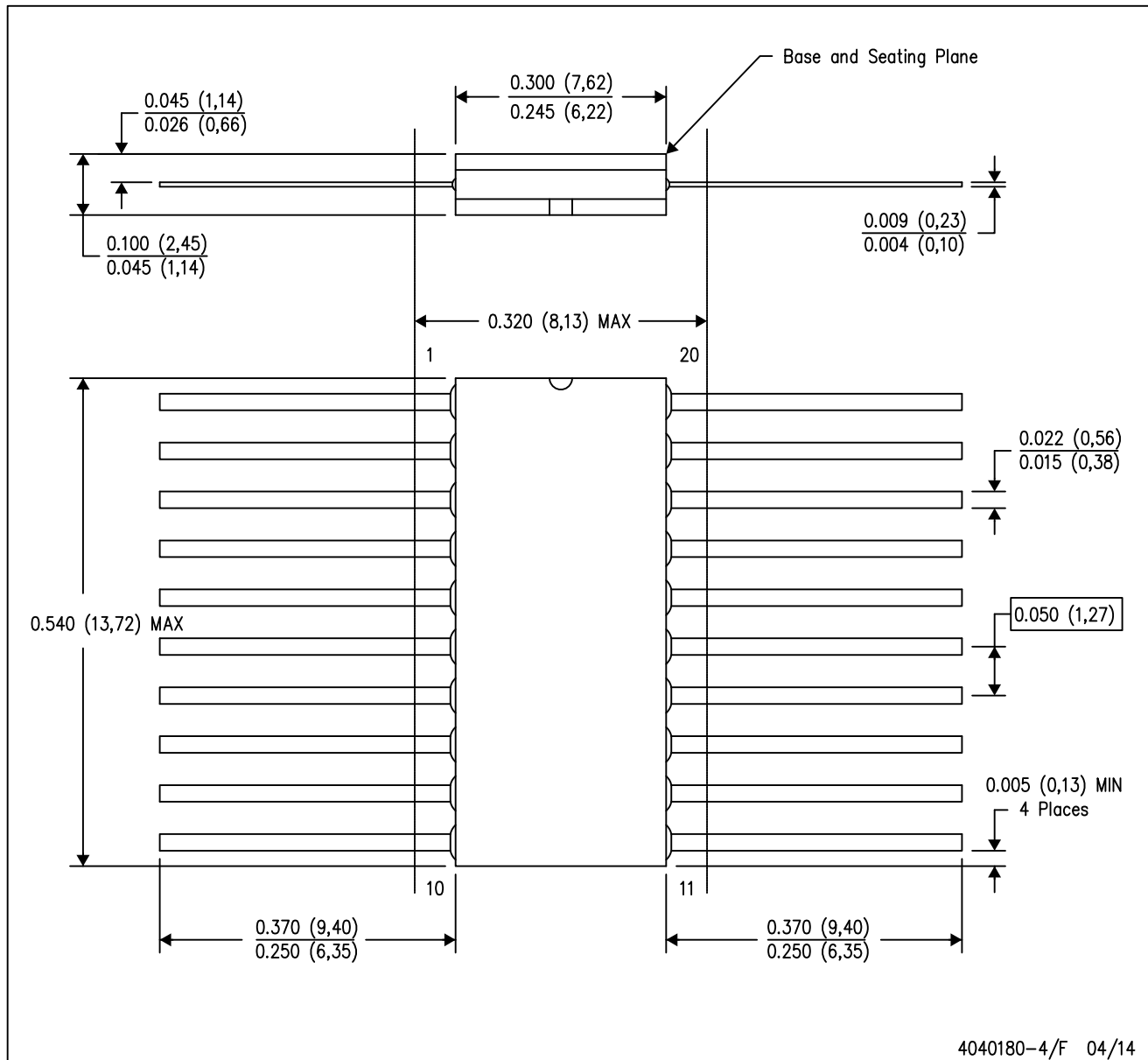

4040180-4/F 04/14

- NOTES:
- A. All linear dimensions are in inches (millimeters).
 - B. This drawing is subject to change without notice.
 - C. This package can be hermetically sealed with a ceramic lid using glass frit.
 - D. Index point is provided on cap for terminal identification only.
 - E. Falls within Mil-Std 1835 GDFP2-F20

IMPORTANT NOTICE AND DISCLAIMER

TI PROVIDES TECHNICAL AND RELIABILITY DATA (INCLUDING DATASHEETS), DESIGN RESOURCES (INCLUDING REFERENCE DESIGNS), APPLICATION OR OTHER DESIGN ADVICE, WEB TOOLS, SAFETY INFORMATION, AND OTHER RESOURCES "AS IS" AND WITH ALL FAULTS, AND DISCLAIMS ALL WARRANTIES, EXPRESS AND IMPLIED, INCLUDING WITHOUT LIMITATION ANY IMPLIED WARRANTIES OF MERCHANTABILITY, FITNESS FOR A PARTICULAR PURPOSE OR NON-INFRINGEMENT OF THIRD PARTY INTELLECTUAL PROPERTY RIGHTS.

These resources are intended for skilled developers designing with TI products. You are solely responsible for (1) selecting the appropriate TI products for your application, (2) designing, validating and testing your application, and (3) ensuring your application meets applicable standards, and any other safety, security, regulatory or other requirements.

These resources are subject to change without notice. TI grants you permission to use these resources only for development of an application that uses the TI products described in the resource. Other reproduction and display of these resources is prohibited. No license is granted to any other TI intellectual property right or to any third party intellectual property right. TI disclaims responsibility for, and you fully indemnify TI and its representatives against any claims, damages, costs, losses, and liabilities arising out of your use of these resources.

TI's products are provided subject to [TI's Terms of Sale](#), [TI's General Quality Guidelines](#), or other applicable terms available either on ti.com or provided in conjunction with such TI products. TI's provision of these resources does not expand or otherwise alter TI's applicable warranties or warranty disclaimers for TI products. Unless TI explicitly designates a product as custom or customer-specified, TI products are standard, catalog, general purpose devices.

TI objects to and rejects any additional or different terms you may propose.

Copyright © 2026, Texas Instruments Incorporated

Last updated 10/2025