

TIBPAL 16L8-15C, TIBPAL 16R4-15C, TIBPAL 16R6-15C, TIBPAL 16R8-15C TIBPAL 16L8-20M, TIBPAL 16R4-20M, TIBPAL 16R6-20M, TIBPAL 16R8-20M HIGH-PERFORMANCE *IMPACT*™ PAL® CIRCUITS

SRPS019A – FEBRUARY 1984 – REVISED APRIL 2000

- **High-Performance Operation:**
Propagation Delay
C Suffix . . . 15 ns Max
M Suffix . . . 20 ns Max
- **Functionally Equivalent, but Faster Than**
PAL16L8A, PAL16R4A, PAL16R6A, and
PAL16R8A
- **Power-Up Clear on Registered Devices (All**
Register Outputs Are Set High, but Voltage
Levels at the Output Pins Go Low)
- **Package Options Include Both Plastic and**
Ceramic Chip Carriers in Addition to
Plastic and Ceramic DIPs
- **Dependable Texas Instruments Quality and**
Reliability

DEVICE	I INPUTS	3-STATE O OUTPUTS	REGISTERED Q OUTPUTS	I/O PORTS
PAL16L8	10	2	0	6
PAL16R4	8	0	4 (3-state buffers)	4
PAL16R6	8	0	6 (3-state buffers)	2
PAL16R8	8	0	8 (3-state buffers)	0

description

These programmable array logic devices feature high speed and functional equivalency when compared with currently available devices. These *IMPACT*™ circuits combine the latest Advanced Low-Power Schottky technology with proven titanium-tungsten fuses to provide reliable, high-performance substitutes for conventional TTL logic. Their easy programmability allows for quick design of custom functions and typically results in a more compact circuit board. In addition, chip carriers are available for further reduction in board space.

The TIBPAL16' C series is characterized from 0°C to 75°C. The TIBPAL16' M series is characterized for operation over the full military temperature range of -55°C to 125°C.



Please be aware that an important notice concerning availability, standard warranty, and use in critical applications of Texas Instruments semiconductor products and disclaimers thereto appears at the end of this data sheet.

These devices are covered by U.S. Patent 4,410,987.
IMPACT is a trademark of Texas Instruments.
PAL is a registered trademark of Advanced Micro Devices Inc.

TIBPAL16L8'
C SUFFIX . . . J OR N PACKAGE
M SUFFIX . . . J OR W PACKAGE
(TOP VIEW)

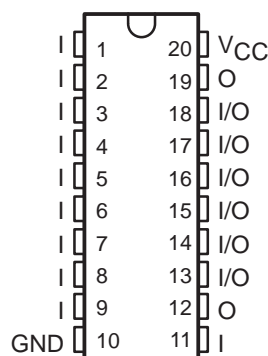

TIBPAL16L8'
C SUFFIX . . . FN PACKAGE
M SUFFIX . . . FK PACKAGE
(TOP VIEW)

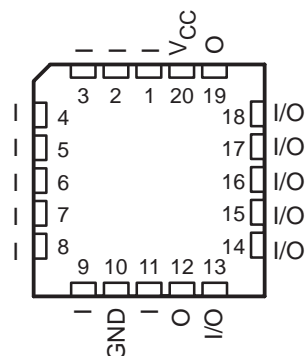

TIBPAL 16R4-15C, TIBPAL 16R6-15C, TIBPAL 16R8-15C
TIBPAL 16R4-20M, TIBPAL 16R6-20M, TIBPAL 16R8-20M
HIGH-PERFORMANCE *IMPACT*™ PAL® CIRCUITS

SRPS019A – FEBRUARY 1984 – REVISED APRIL 2000

TIBPAL16R4'
C SUFFIX ... J OR N PACKAGE
M SUFFIX ... J OR W PACKAGE
(TOP VIEW)



TIBPAL16R4'
C SUFFIX ... FN PACKAGE
M SUFFIX ... FK PACKAGE
(TOP VIEW)

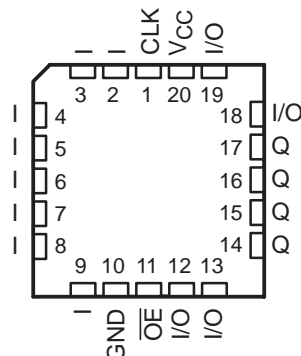

TIBPAL16R6'
C SUFFIX ... J OR N PACKAGE
M SUFFIX ... J OR W PACKAGE
(TOP VIEW)

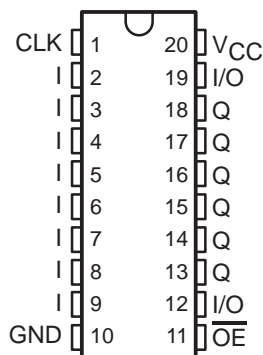

TIBPAL16R6'
C SUFFIX ... FN PACKAGE
M SUFFIX ... FK PACKAGE
(TOP VIEW)

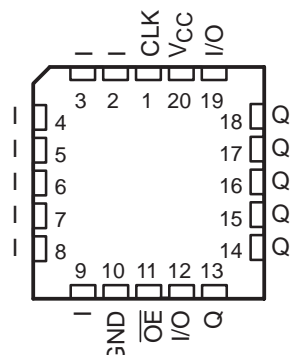

TIBPAL16R8'
C SUFFIX ... J OR N PACKAGE
M SUFFIX ... J OR W PACKAGE
(TOP VIEW)

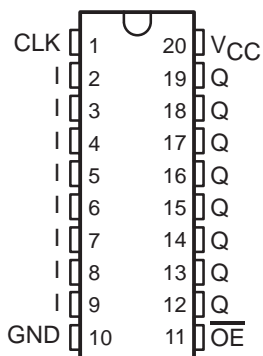

TIBPAL16R8'
C SUFFIX ... FN PACKAGE
M SUFFIX ... FK PACKAGE
(TOP VIEW)

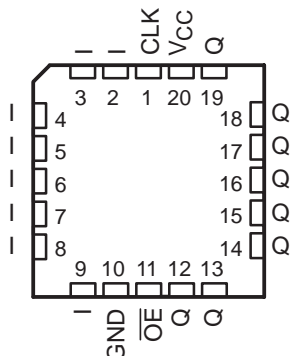

functional block diagrams (positive logic)

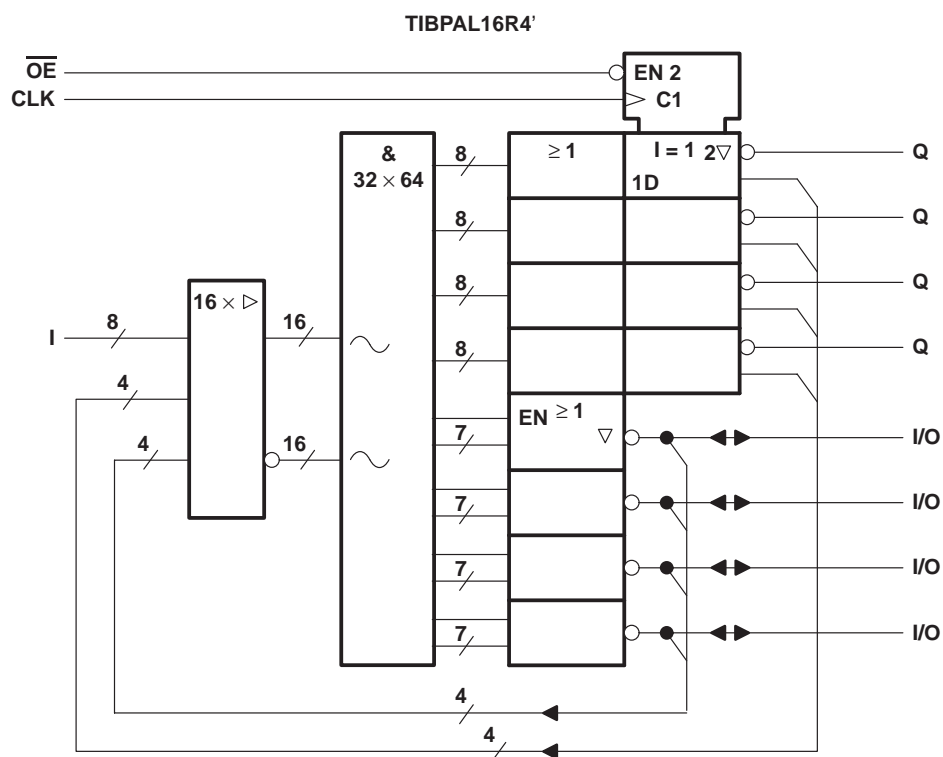
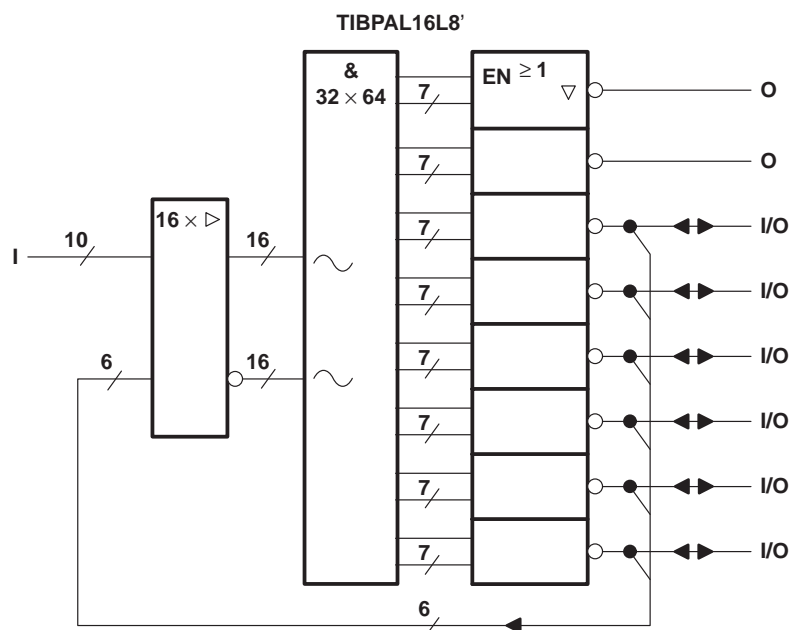

~ denotes fused inputs

TIBPAL 16R6-15C, TIBPAL 16R8-15C
 TIBPAL 16R6-20M, TIBPAL 16R8-20M
 HIGH-PERFORMANCE *IMPACT*™ *PAL*® CIRCUITS
 SRPS019A – FEBRUARY 1984 – REVISED APRIL 2000

functional block diagrams (positive logic)

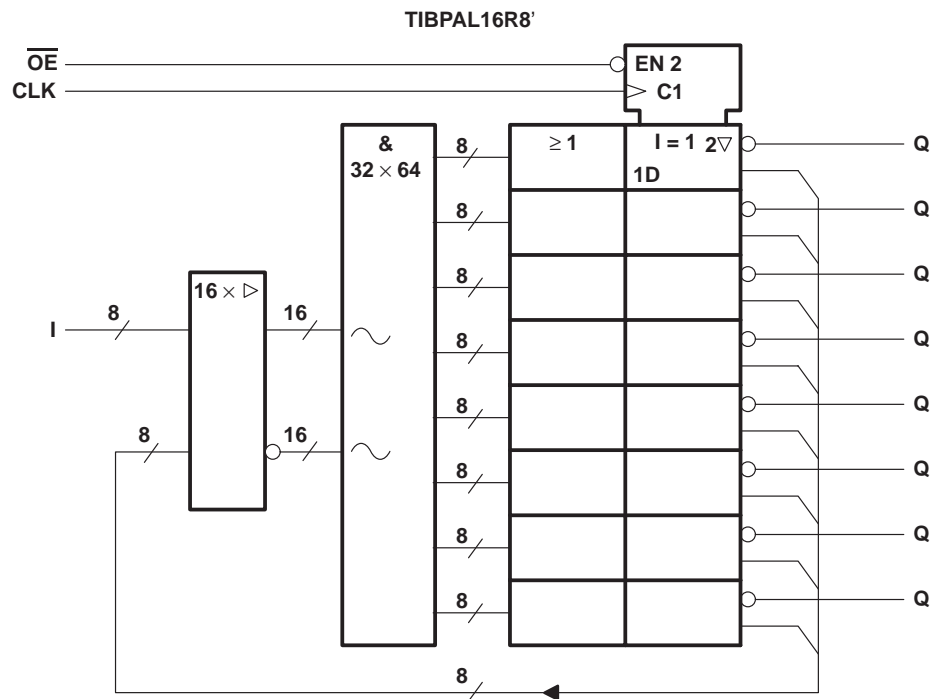
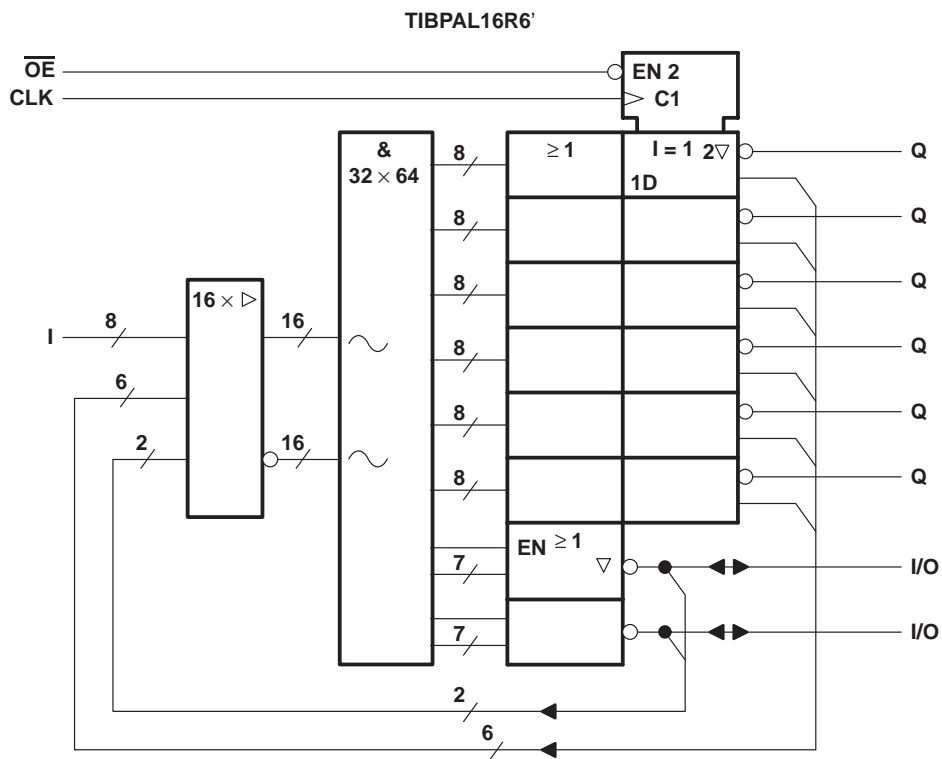

⋯ denotes fused inputs

logic diagram (positive logic)

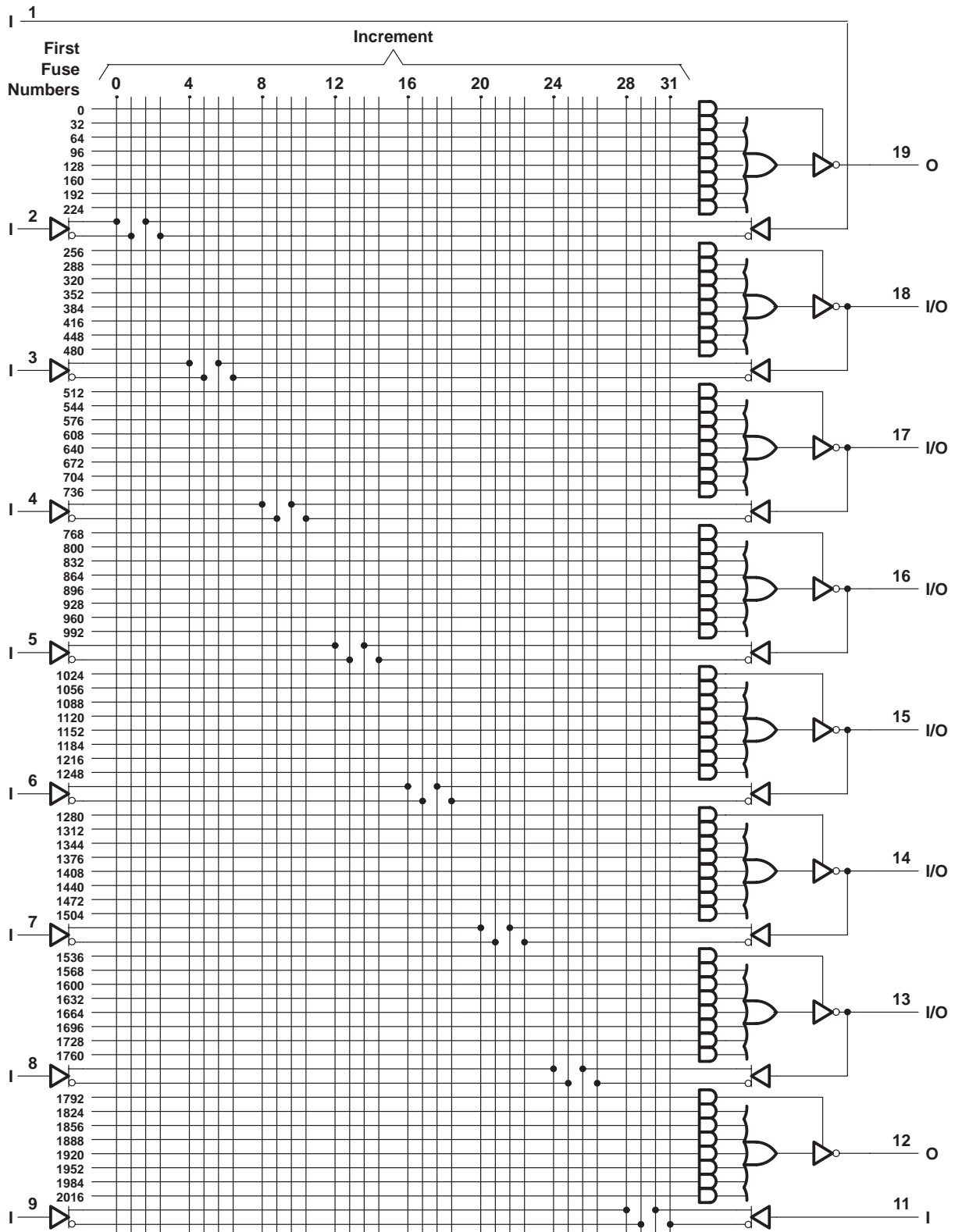

Fuse number = First fuse number + Increment



TIBPAL 16R4-15C
TIBPAL 16R4-20M
HIGH-PERFORMANCE *IMPACT*™ PAL® CIRCUITS
 SRPS019A – FEBRUARY 1984 – REVISED APRIL 2000

logic diagram (positive logic)

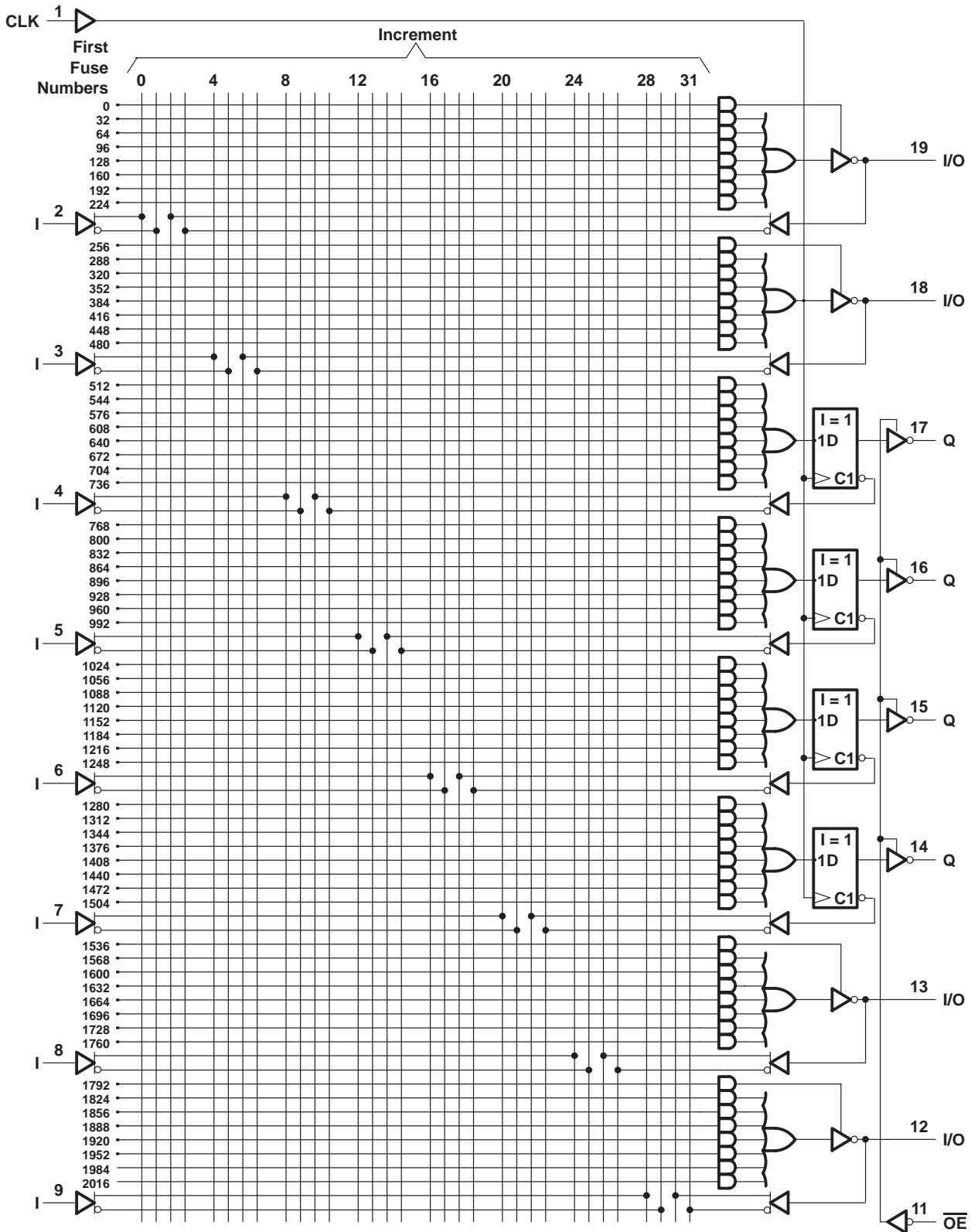

Fuse number = First fuse number + Increment



logic diagram (positive logic)

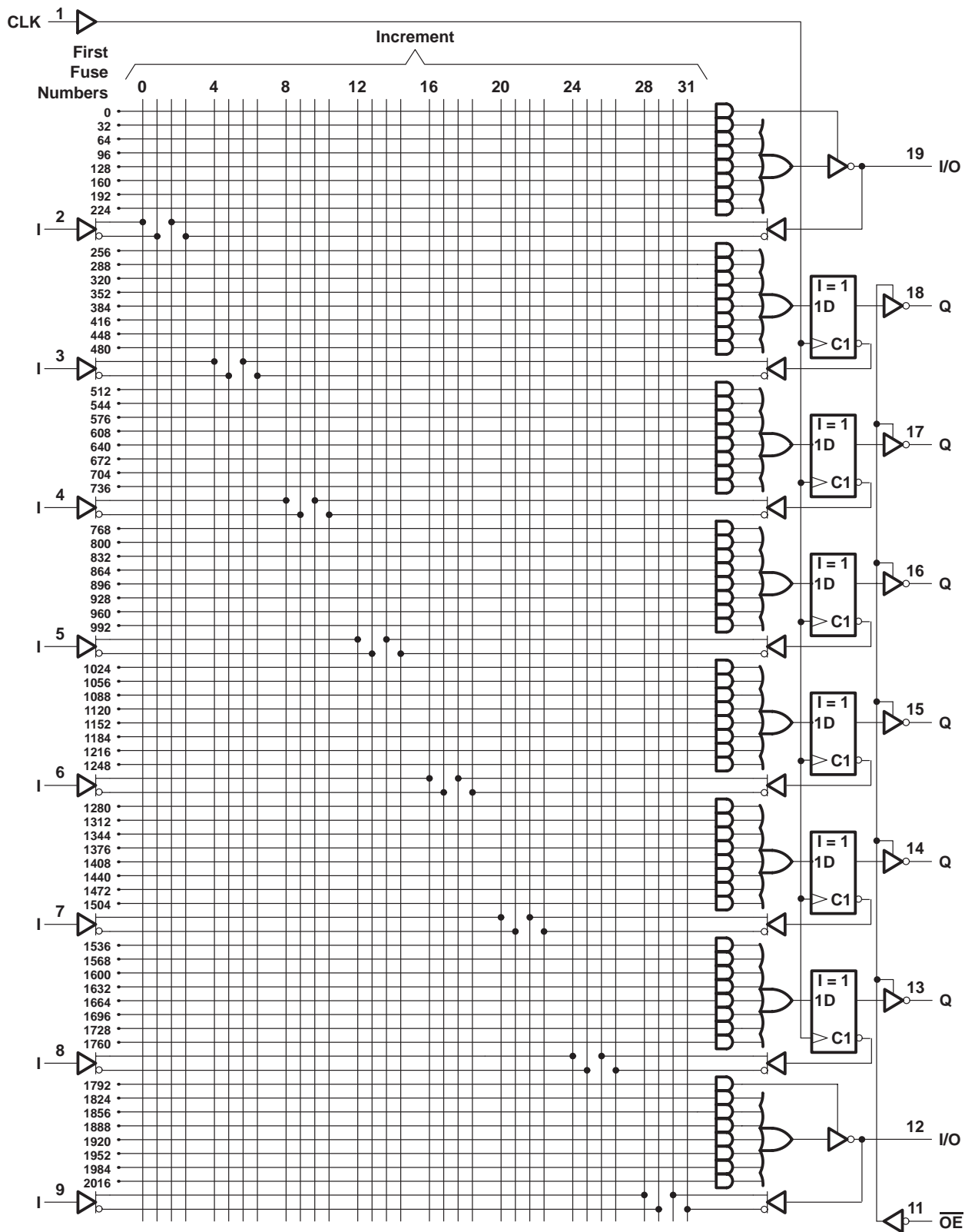

Fuse number = First fuse number + Increment



TIBPAL 16R8-15C TIBPAL 16R8-20M HIGH-PERFORMANCE *IMPACT*™ PAL® CIRCUITS

SRPS019A – FEBRUARY 1984 – REVISED APRIL 2000

logic diagram (positive logic)

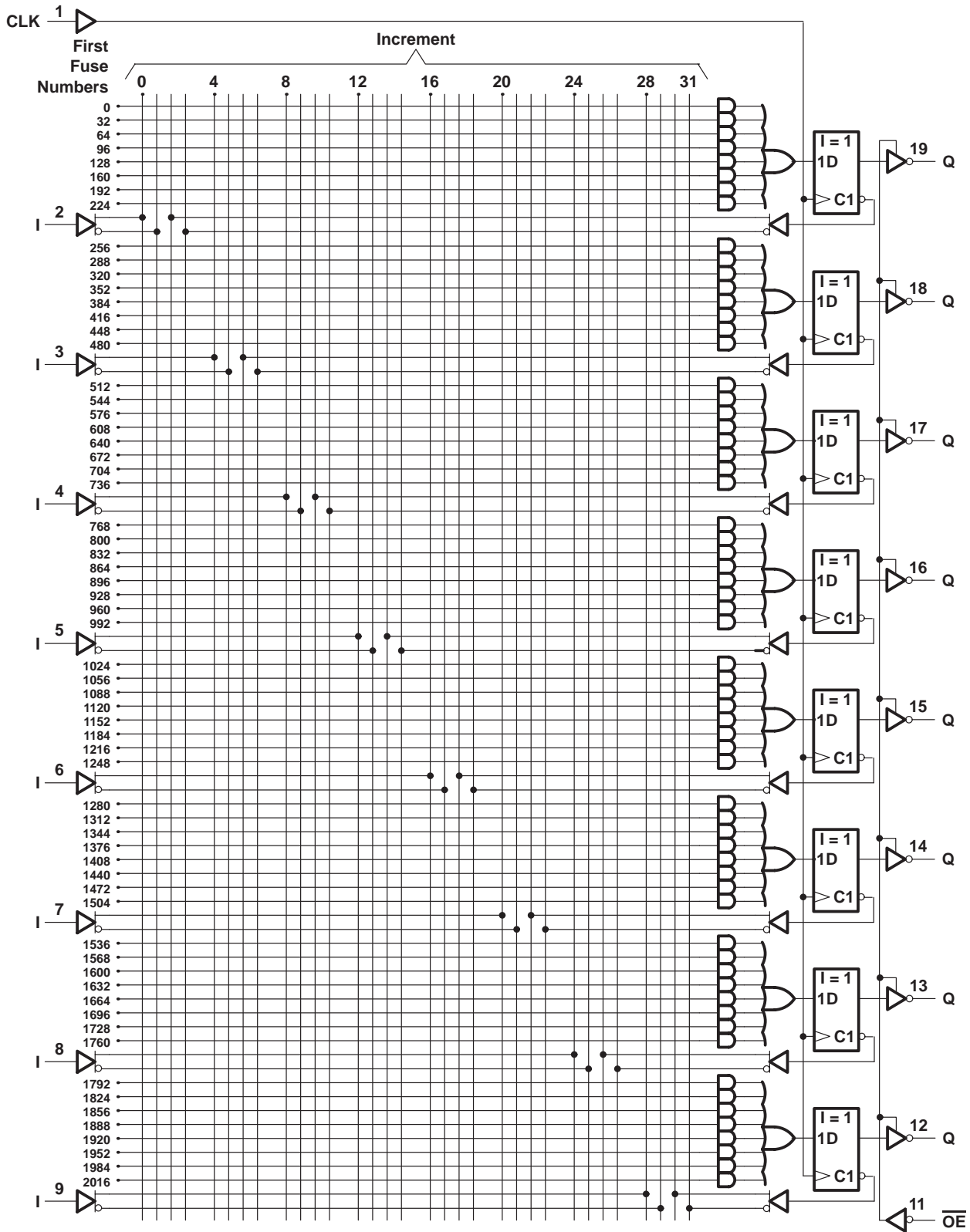

Fuse number = First fuse number + Increment



TIBPAL 16L8-15C, TIBPAL 16R4-15C, TIBPAL 16R6-15C, TIBPAL 16R8-15C HIGH-PERFORMANCE *IMPACT*™ *PAL*® CIRCUITS

SRPS019A – FEBRUARY 1984 – REVISED APRIL 2000

absolute maximum ratings over operating free-air temperature range (unless otherwise noted)

Supply voltage, V_{CC} (see Note 1)	7 V
Input voltage (see Note 1)	5.5 V
Voltage applied to disabled output (see Note 1)	5.5 V
Operating free-air temperature range	0°C to 75°C
Storage temperature range, T_{stg}	–65°C to 150°C

NOTE 1: These ratings apply, except for programming pins, during a programming cycle.

recommended operating conditions

		MIN	NOM	MAX	UNIT
V_{CC}	Supply voltage	4.75	5	5.25	V
V_{IH}	High-level input voltage	2		5.5	V
V_{IL}	Low-level input voltage			0.8	V
I_{OH}	High-level output current			–3.2	mA
I_{OL}	Low-level output current			24	mA
f_{clock}	Clock frequency	0		50	MHz
t_w	Pulse duration, clock (see Note 2)	High	8		ns
		Low	9		
t_{su}	Setup time, input or feedback before clock↑	15			ns
t_h	Hold time, input or feedback after clock↑	0			ns
T_A	Operating free-air temperature	0	25	75	°C

NOTE 2: The total clock period of clock high and clock low must not exceed clock frequency, f_{clock} . The minimum pulse durations specified are for clock high or low only, but not for both simultaneously.

TIBPAL 16L8-15C, TIBPAL 16R4-15C, TIBPAL 16R6-15C, TIBPAL 16R8-15C

HIGH-PERFORMANCE *IMPACT*™ *PAL*® CIRCUITS

SRPS019A – FEBRUARY 1984 – REVISED APRIL 2000

electrical characteristics over recommended operating free-air temperature range

PARAMETER		TEST CONDITIONS		MIN	TYP†	MAX	UNIT	
V_{IK}		$V_{CC} = 4.75 \text{ V}$,	$I_I = -18 \text{ mA}$			-1.5	V	
V_{OH}		$V_{CC} = 4.75 \text{ V}$,	$I_{OH} = -3.2 \text{ mA}$	2.4	3.3		V	
V_{OL}		$V_{CC} = 4.75 \text{ V}$,	$I_{OL} = 24 \text{ mA}$		0.35	0.5	V	
I_{OZH}	Outputs	$V_{CC} = 5.25 \text{ V}$,	$V_O = 2.7 \text{ V}$			20	μA	
	I/O ports					100		
I_{OZL}	Outputs	$V_{CC} = 5.25 \text{ V}$,	$V_O = 0.4 \text{ V}$			-20	μA	
	I/O ports					-250		
I_I		$V_{CC} = 5.25 \text{ V}$,	$V_I = 5.5 \text{ V}$			0.1	mA	
I_{IH}		$V_{CC} = 5.25 \text{ V}$,	$V_I = 2.7 \text{ V}$			20	μA	
I_{IL}		$V_{CC} = 5.25 \text{ V}$,	$V_I = 0.4 \text{ V}$			-0.2	mA	
$I_{O\ddagger}$		$V_{CC} = 5.25 \text{ V}$,	$V_O = 2.25 \text{ V}$	-30		-125	mA	
I_{CC}		$V_{CC} = 5.25 \text{ V}$,	$V_I = 0$,			140	180	mA
			Outputs open					

† All typical values are at $V_{CC} = 5 \text{ V}$, $T_A = 25^\circ\text{C}$.‡ The output conditions have been chosen to produce a current that closely approximates one-half of the short-circuit output current, I_{OS} .

switching characteristics over recommended ranges of supply voltage and operating free-air temperature (unless otherwise noted)

PARAMETER	FROM (INPUT)	TO (OUTPUT)	TEST CONDITIONS	MIN	TYP†	MAX	UNIT
f_{max}			R1 = 500 Ω , R2 = 500 Ω , See Figure 3	50			MHz
t_{pd}	I, I/O	O, I/O		10	15		ns
t_{pd}	CLK↑	Q		8	12		ns
t_{en}	OE↓	Q		8	12		ns
t_{dis}	OE↑	Q		7	10		ns
t_{en}	I, I/O	O, I/O		10	15		ns
t_{dis}	I, I/O	O, I/O		10	15		ns

† All typical values are at $V_{CC} = 5 \text{ V}$, $T_A = 25^\circ\text{C}$.

TIBPAL 16L8-20M, TIBPAL 16R4-20M, TIBPAL 16R6-20M, TIBPAL 16R8-20M HIGH-PERFORMANCE *IMPACT*™ *PAL*® CIRCUITS

SRPS019A – FEBRUARY 1984 – REVISED APRIL 2000

absolute maximum ratings over operating free-air temperature range (unless otherwise noted)

Supply voltage, V_{CC} (see Note 1)	7 V
Input voltage (see Note 1)	5.5 V
Voltage applied to disabled output (see Note 1)	5.5 V
Operating free-air temperature range	-55°C to 125°C
Storage temperature range, T_{stg}	-65°C to 150°C

NOTE 1: These ratings apply, except for programming pins, during a programming cycle.

recommended operating conditions

		MIN	NOM	MAX	UNIT
V_{CC}	Supply voltage	4.5	5	5.5	V
V_{IH}	High-level input voltage	2		5.5	V
V_{IL}	Low-level input voltage			0.8	V
I_{OH}	High-level output current			-2	mA
I_{OL}	Low-level output current			12	mA
f_{clock}	Clock frequency	0		41.6	MHz
t_w	Pulse duration, clock (see Note 2)	High	10		ns
		Low	11		
t_{su}	Setup time, input or feedback before clock \uparrow	20			ns
t_h	Hold time, input or feedback after clock \uparrow	0			ns
T_A	Operating free-air temperature	-55	25	125	°C

NOTE 2: The total clock period of clock high and clock low must not exceed clock frequency, f_{clock} . The minimum pulse durations specified are for clock high or low only, but not for both simultaneously.

TIBPAL 16L8-20M, TIBPAL 16R4-20M, TIBPAL 16R6-20M, TIBPAL 16R8-20M

HIGH-PERFORMANCE *IMPACT*™ *PAL*® CIRCUITS

SRPS019A – FEBRUARY 1984 – REVISED APRIL 2000

electrical characteristics over recommended operating free-air temperature range

PARAMETER		TEST CONDITIONS		MIN	TYP†	MAX	UNIT
V _{IK}		V _{CC} = 4.5 V,	I _I = -18 mA			-1.5	V
V _{OH}		V _{CC} = 4.5 V,	I _{OH} = -2 mA	2.4	3.2		V
V _{OL}		V _{CC} = 4.5 V,	I _{OL} = 12 mA		0.25	0.4	V
I _{OZH}	Outputs	V _{CC} = 5.5 V,	V _O = 2.7 V			20	μA
	I/O ports					100	
I _{OZL}	Outputs	V _{CC} = 5.5 V,	V _O = 0.4 V			-20	μA
	I/O ports					-250	
I _I	Pin 1, 11	V _{CC} = 5.5 V,	V _I = 5.5 V			0.2	mA
	All others					0.1	
I _{IH}	Pin 1, 11	V _{CC} = 5.5 V,	V _I = 2.7 V			50	μA
	I/O ports					100	
	All others					20	
I _{IL}	I/O ports	V _{CC} = 5.5 V,	V _I = 0.4 V			-0.25	mA
	All others					-0.2	
I _{OS} ‡		V _{CC} = 5.5 V,	V _O = 0.5 V	-30		-250	mA
I _{CC}		V _{CC} = 5.5 V,	V _I = 0, Outputs open		140	190	mA

† All typical values are at V_{CC} = 5 V, T_A = 25°C.‡ Not more than one output should be shorted at a time and the duration of the short circuit should not exceed one second. Set V_O at 0.5 V to avoid test-equipment degradation.

switching characteristics over recommended ranges of supply voltage and operating free-air temperature (unless otherwise noted)

PARAMETER	FROM (INPUT)	TO (OUTPUT)	TEST CONDITIONS	MIN	TYP†	MAX	UNIT	
f _{max}			R1 = 390 Ω, R2 = 750 Ω, See Figure 4	41.6			MHz	
t _{pd}	I, I/O	O, I/O				10	20	ns
t _{pd}	CLK↑	Q				8	15	ns
t _{en}	OE↓	Q				8	15	ns
t _{dis}	OE↑	Q				7	15	ns
t _{en}	I, I/O	O, I/O				10	20	ns
t _{dis}	I, I/O	O, I/O				10	20	ns

† All typical values are at V_{CC} = 5 V, T_A = 25°C.

programming information

Texas Instruments programmable logic devices can be programmed using widely available software and inexpensive device programmers.

Complete programming specifications, algorithms, and the latest information on hardware, software, and firmware are available upon request. Information on programmers capable of programming Texas Instruments programmable logic also is available, upon request, from the nearest TI field sales office or local authorized TI distributor, by calling Texas Instruments at +1 (972) 644-5580, or by visiting the TI Semiconductor Home Page at www.ti.com/sc.

preload procedure for registered outputs (see Figure 1 and Note 3)

The output registers can be preloaded to any desired state during device testing. This permits any state to be tested without having to step through the entire state-machine sequence. Each register is preloaded individually by following the steps given below.

- Step 1. With V_{CC} at 5 V and Pin 1 at V_{IL} , raise Pin 11 to V_{IHH} .
- Step 2. Apply either V_{IL} or V_{IH} to the output corresponding to the register to be preloaded.
- Step 3. Pulse Pin 1, clocking in preload data.
- Step 4. Remove output voltage, then lower Pin 11 to V_{IL} . Preload can be verified by observing the voltage level at the output pin.

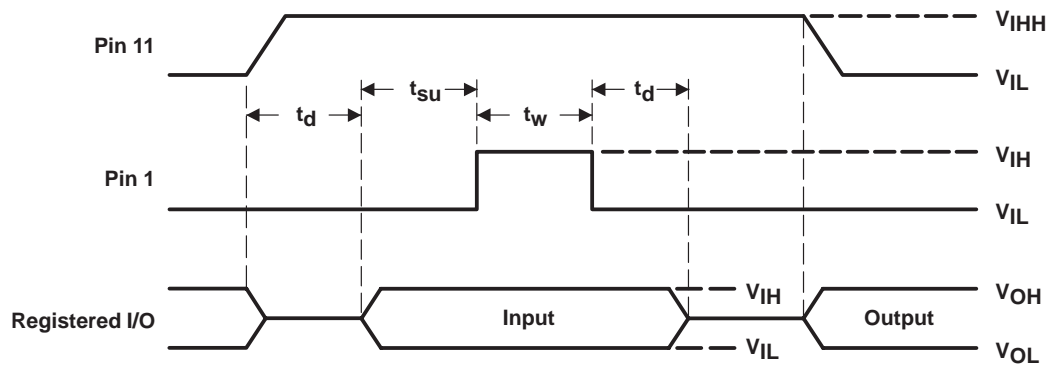

NOTE 3: $t_d = t_{su} = t_h = 100$ ns to 1000 ns $V_{IHH} = 10.25$ V to 10.75 V

Figure 1. Preload Waveforms

TIBPAL 16L8-15C, TIBPAL 16R4-15C, TIBPAL 16R6-15C, TIBPAL 16R8-15C
 TIBPAL 16L8-20M, TIBPAL 16R4-20M, TIBPAL 16R6-20M, TIBPAL 16R8-20M
 HIGH-PERFORMANCE *IMPACT*™ *PAL*® CIRCUITS

SRPS019A – FEBRUARY 1984 – REVISED APRIL 2000

power-up reset (see Figure 2)

Following power up, all registers are set high. This feature provides extra flexibility to the system designer and is especially valuable in simplifying state-machine initialization. To ensure a valid power-up reset, it is important that the rise of V_{CC} be monotonic. Following power-up reset, a low-to-high clock transition must not occur until all applicable input and feedback setup times are met.

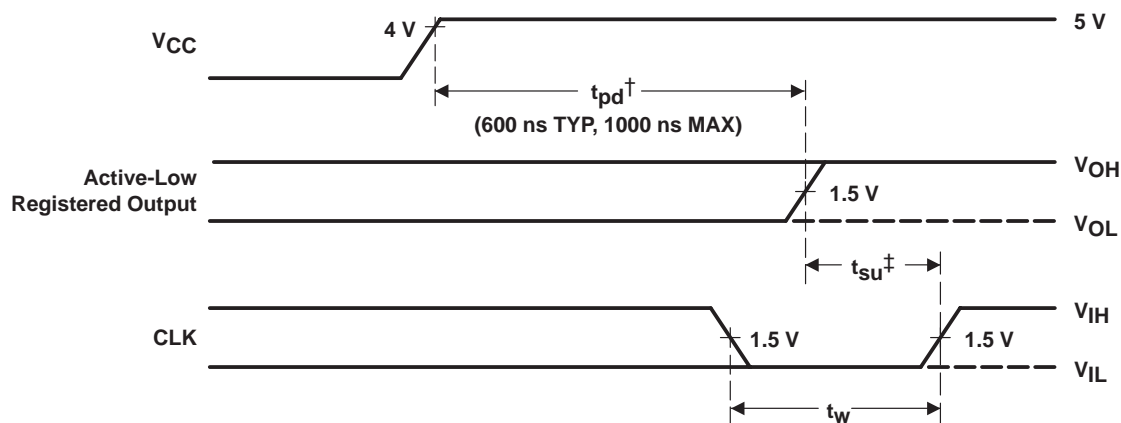

† This is the power-up reset time and applies to registered outputs only. The values shown are from characterization data.

‡ This is the setup time for input or feedback.

Figure 2. Power-Up Reset Waveforms

PARAMETER MEASUREMENT INFORMATION

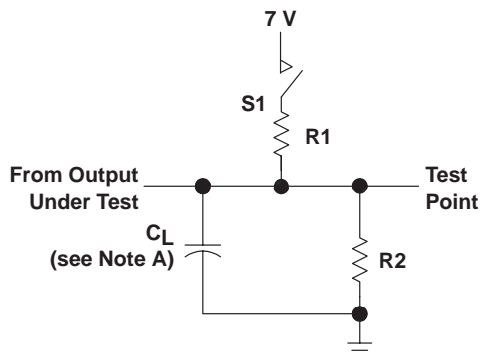

LOAD CIRCUIT FOR 3-STATE OUTPUTS

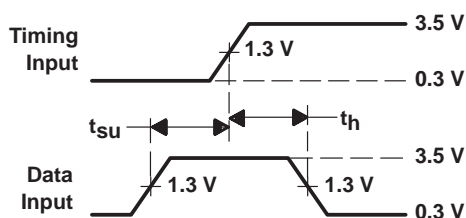

VOLTAGE WAVEFORMS
SETUP AND HOLD TIMES

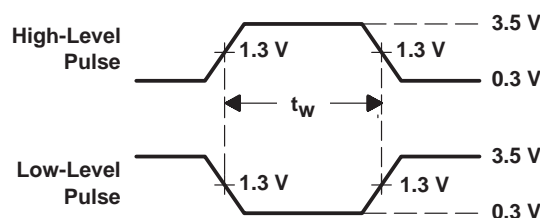

VOLTAGE WAVEFORMS
PULSE DURATIONS

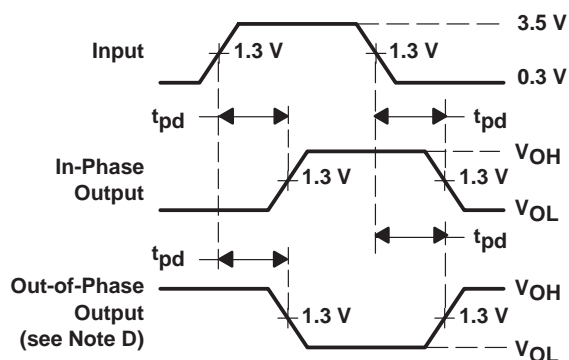

VOLTAGE WAVEFORMS
PROPAGATION DELAY TIMES

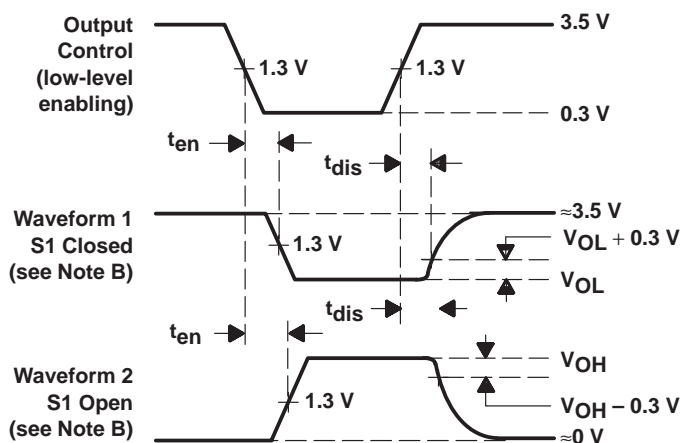

VOLTAGE WAVEFORMS
ENABLE AND DISABLE TIMES, 3-STATE OUTPUTS

- NOTES: A. C_L includes probe and jig capacitance and is 50 pF for t_{pd} and t_{en} , 5 pF for t_{dis} .
 B. Waveform 1 is for an output with internal conditions such that the output is low except when disabled by the output control. Waveform 2 is for an output with internal conditions such that the output is high except when disabled by the output control.
 C. All input pulses have the following characteristics: $PRR \leq 1$ MHz, $t_r = t_f \leq 2$ ns, duty cycle = 50%.
 D. When measuring propagation delay times of 3-state outputs from low to high, switch S1 is closed. When measuring propagation delay times of 3-state outputs from high to low, switch S1 is open.
 E. Equivalent loads may be used for testing.

Figure 3. Load Circuit and Voltage Waveforms

TIBPAL 16L8-20M, TIBPAL 16R4-20M, TIBPAL 16R6-20M, TIBPAL 16R8-20M HIGH-PERFORMANCE *IMPACT*™ *PAL*® CIRCUITS

SRPS019A – FEBRUARY 1984 – REVISED APRIL 2000

PARAMETER MEASUREMENT INFORMATION

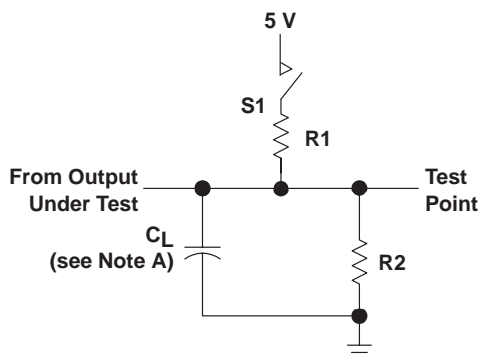

LOAD CIRCUIT FOR 3-STATE OUTPUTS

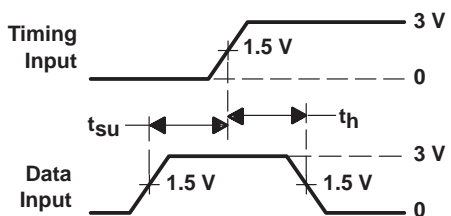

VOLTAGE WAVEFORMS
SETUP AND HOLD TIMES

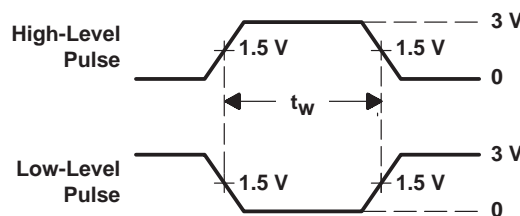

VOLTAGE WAVEFORMS
PULSE DURATIONS

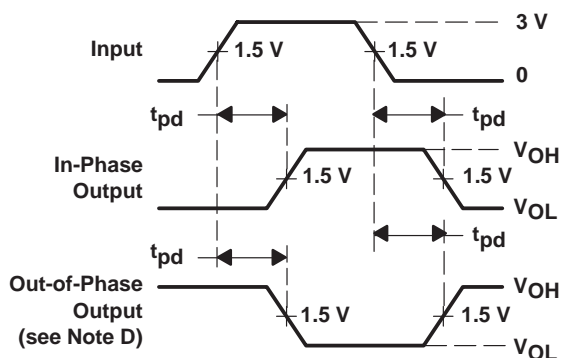

VOLTAGE WAVEFORMS
PROPAGATION DELAY TIMES

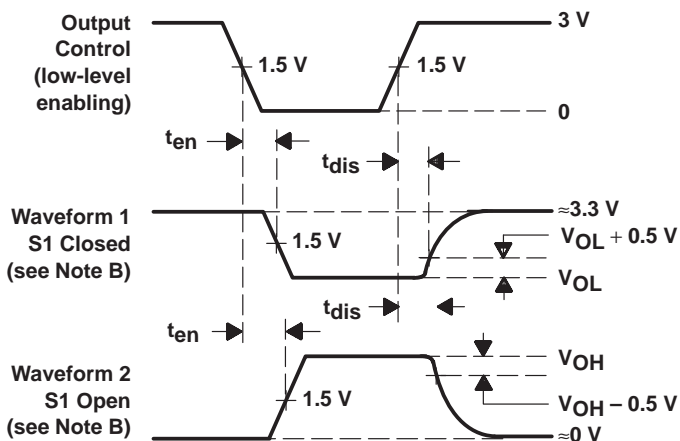

VOLTAGE WAVEFORMS
ENABLE AND DISABLE TIMES, 3-STATE OUTPUTS

- NOTES: A. C_L includes probe and jig capacitance and is 50 pF for t_{pd} and t_{en} , 5 pF for t_{dis} .
 B. Waveform 1 is for an output with internal conditions such that the output is low except when disabled by the output control. Waveform 2 is for an output with internal conditions such that the output is high except when disabled by the output control.
 C. All input pulses have the following characteristics: $PRR \leq 10$ MHz, $t_r = t_f \leq 2$ ns, duty cycle = 50%
 D. When measuring propagation delay times of 3-state outputs, switch S1 is closed.
 E. Equivalent loads may be used for testing.

Figure 4. Load Circuit and Voltage Waveforms

PACKAGING INFORMATION

Orderable part number	Status (1)	Material type (2)	Package Pins	Package qty Carrier	RoHS (3)	Lead finish/ Ball material (4)	MSL rating/ Peak reflow (5)	Op temp (°C)	Part marking (6)
5962-85155012A	Active	Production	LCCC (FK) 20	55 TUBE	No	SNPB	N/A for Pkg Type	-55 to 125	5962- 85155012A TIBPAL16 L8-20MFKB
5962-8515501RA	Active	Production	CDIP (J) 20	20 TUBE	No	SNPB	N/A for Pkg Type	-55 to 125	5962-8515501RA TIBPAL16L8-20M JB
5962-8515501SA	Active	Production	CFP (W) 20	25 TUBE	No	SNPB	N/A for Pkg Type	-55 to 125	5962-8515501SA TIBPAL16L8-20M WB
5962-85155022A	NRND	Production	LCCC (FK) 20	55 TUBE	No	SNPB	N/A for Pkg Type	-55 to 125	5962- 85155022A TIBPAL16 R8-20MFKB
5962-8515502RA	NRND	Production	CDIP (J) 20	20 TUBE	No	SNPB	N/A for Pkg Type	-55 to 125	5962-8515502RA TIBPAL16R8-20M JB
5962-85155032A	NRND	Production	LCCC (FK) 20	55 TUBE	No	SNPB	N/A for Pkg Type	-55 to 125	5962- 85155032A TIBPAL16 R6-20MFKB
5962-8515503RA	NRND	Production	CDIP (J) 20	20 TUBE	No	SNPB	N/A for Pkg Type	-55 to 125	5962-8515503RA TIBPAL16R6-20M JB
5962-8515503SA	NRND	Production	CFP (W) 20	25 TUBE	No	SNPB	N/A for Pkg Type	-55 to 125	5962-8515503SA TIBPAL16R6-20M WB
5962-85155042A	Active	Production	LCCC (FK) 20	55 TUBE	No	SNPB	N/A for Pkg Type	-55 to 125	5962- 85155042A TIBPAL16 R4-20MFKB
5962-8515504RA	Active	Production	CDIP (J) 20	20 TUBE	No	SNPB	N/A for Pkg Type	-55 to 125	5962-8515504RA TIBPAL16R4-20M JB

Orderable part number	Status (1)	Material type (2)	Package Pins	Package qty Carrier	RoHS (3)	Lead finish/ Ball material (4)	MSL rating/ Peak reflow (5)	Op temp (°C)	Part marking (6)
5962-8515504SA	Active	Production	CFP (W) 20	25 TUBE	No	SNPB	N/A for Pkg Type	-55 to 125	5962-8515504SA TIBPAL16R4-20M WB
JM38510/50601BRA	Active	Production	CDIP (J) 20	20 TUBE	No	SNPB	N/A for Pkg Type	-55 to 125	JM38510/ 50601BRA
JM38510/50601BRA.A	Active	Production	CDIP (J) 20	20 TUBE	No	SNPB	N/A for Pkg Type	-55 to 125	JM38510/ 50601BRA
JM38510/50604BRA	Active	Production	CDIP (J) 20	20 TUBE	No	SNPB	N/A for Pkg Type	-55 to 125	JM38510/ 50604BRA
JM38510/50604BRA.A	Active	Production	CDIP (J) 20	20 TUBE	No	SNPB	N/A for Pkg Type	-55 to 125	JM38510/ 50604BRA
M38510/50601BRA	Active	Production	CDIP (J) 20	20 TUBE	No	SNPB	N/A for Pkg Type	-55 to 125	JM38510/ 50601BRA
M38510/50604BRA	Active	Production	CDIP (J) 20	20 TUBE	No	SNPB	N/A for Pkg Type	-55 to 125	JM38510/ 50604BRA
TIBPAL16L8-20MFKB	Active	Production	LCCC (FK) 20	55 TUBE	No	SNPB	N/A for Pkg Type	-55 to 125	5962- 85155012A TIBPAL16 L8-20MFKB
TIBPAL16L8-20MFKB.A	Active	Production	LCCC (FK) 20	55 TUBE	No	SNPB	N/A for Pkg Type	-55 to 125	5962- 85155012A TIBPAL16 L8-20MFKB
TIBPAL16L8-20MJ	Active	Production	CDIP (J) 20	20 TUBE	No	SNPB	N/A for Pkg Type	-55 to 125	TIBPAL16L8-20M J
TIBPAL16L8-20MJ.A	Active	Production	CDIP (J) 20	20 TUBE	No	SNPB	N/A for Pkg Type	-55 to 125	TIBPAL16L8-20M J
TIBPAL16L8-20MJB	Active	Production	CDIP (J) 20	20 TUBE	No	SNPB	N/A for Pkg Type	-55 to 125	5962-8515501RA TIBPAL16L8-20M JB
TIBPAL16L8-20MJB.A	Active	Production	CDIP (J) 20	20 TUBE	No	SNPB	N/A for Pkg Type	-55 to 125	5962-8515501RA TIBPAL16L8-20M JB
TIBPAL16L8-20MWB	Active	Production	CFP (W) 20	25 TUBE	No	SNPB	N/A for Pkg Type	-55 to 125	5962-8515501SA TIBPAL16L8-20M WB

Orderable part number	Status (1)	Material type (2)	Package Pins	Package qty Carrier	RoHS (3)	Lead finish/ Ball material (4)	MSL rating/ Peak reflow (5)	Op temp (°C)	Part marking (6)
TIBPAL16L8-20MWB.A	Active	Production	CFP (W) 20	25 TUBE	No	SNPB	N/A for Pkg Type	-55 to 125	5962-8515501SA TIBPAL16L8-20M WB
TIBPAL16R4-20MFKB	Active	Production	LCCC (FK) 20	55 TUBE	No	SNPB	N/A for Pkg Type	-55 to 125	5962- 85155042A TIBPAL16 R4-20MFKB
TIBPAL16R4-20MFKB.A	Active	Production	LCCC (FK) 20	55 TUBE	No	SNPB	N/A for Pkg Type	-55 to 125	5962- 85155042A TIBPAL16 R4-20MFKB
TIBPAL16R4-20MJB	Active	Production	CDIP (J) 20	20 TUBE	No	SNPB	N/A for Pkg Type	-55 to 125	5962-8515504RA TIBPAL16R4-20M JB
TIBPAL16R4-20MJB.A	Active	Production	CDIP (J) 20	20 TUBE	No	SNPB	N/A for Pkg Type	-55 to 125	5962-8515504RA TIBPAL16R4-20M JB
TIBPAL16R4-20MWB	Active	Production	CFP (W) 20	25 TUBE	No	SNPB	N/A for Pkg Type	-55 to 125	5962-8515504SA TIBPAL16R4-20M WB
TIBPAL16R4-20MWB.A	Active	Production	CFP (W) 20	25 TUBE	No	SNPB	N/A for Pkg Type	-55 to 125	5962-8515504SA TIBPAL16R4-20M WB
TIBPAL16R6-20MFKB	NRND	Production	LCCC (FK) 20	55 TUBE	No	SNPB	N/A for Pkg Type	-55 to 125	5962- 85155032A TIBPAL16 R6-20MFKB
TIBPAL16R6-20MFKB.A	NRND	Production	LCCC (FK) 20	55 TUBE	No	SNPB	N/A for Pkg Type	-55 to 125	5962- 85155032A TIBPAL16 R6-20MFKB
TIBPAL16R6-20MJB	NRND	Production	CDIP (J) 20	20 TUBE	No	SNPB	N/A for Pkg Type	-55 to 125	5962-8515503RA TIBPAL16R6-20M JB
TIBPAL16R6-20MJB.A	NRND	Production	CDIP (J) 20	20 TUBE	No	SNPB	N/A for Pkg Type	-55 to 125	5962-8515503RA TIBPAL16R6-20M JB

Orderable part number	Status (1)	Material type (2)	Package Pins	Package qty Carrier	RoHS (3)	Lead finish/ Ball material (4)	MSL rating/ Peak reflow (5)	Op temp (°C)	Part marking (6)
TIBPAL16R6-20MWB	NRND	Production	CFP (W) 20	25 TUBE	No	SNPB	N/A for Pkg Type	-55 to 125	5962-8515503SA TIBPAL16R6-20M WB
TIBPAL16R6-20MWB.A	NRND	Production	CFP (W) 20	25 TUBE	No	SNPB	N/A for Pkg Type	-55 to 125	5962-8515503SA TIBPAL16R6-20M WB
TIBPAL16R8-20MFKB	NRND	Production	LCCC (FK) 20	55 TUBE	No	SNPB	N/A for Pkg Type	-55 to 125	5962- 85155022A TIBPAL16 R8-20MFKB
TIBPAL16R8-20MFKB.A	NRND	Production	LCCC (FK) 20	55 TUBE	No	SNPB	N/A for Pkg Type	-55 to 125	5962- 85155022A TIBPAL16 R8-20MFKB
TIBPAL16R8-20MJB	NRND	Production	CDIP (J) 20	20 TUBE	No	SNPB	N/A for Pkg Type	-55 to 125	5962-8515502RA TIBPAL16R8-20M JB
TIBPAL16R8-20MJB.A	NRND	Production	CDIP (J) 20	20 TUBE	No	SNPB	N/A for Pkg Type	-55 to 125	5962-8515502RA TIBPAL16R8-20M JB

⁽¹⁾ **Status:** For more details on status, see our [product life cycle](#).

⁽²⁾ **Material type:** When designated, preproduction parts are prototypes/experimental devices, and are not yet approved or released for full production. Testing and final process, including without limitation quality assurance, reliability performance testing, and/or process qualification, may not yet be complete, and this item is subject to further changes or possible discontinuation. If available for ordering, purchases will be subject to an additional waiver at checkout, and are intended for early internal evaluation purposes only. These items are sold without warranties of any kind.

⁽³⁾ **RoHS values:** Yes, No, RoHS Exempt. See the [TI RoHS Statement](#) for additional information and value definition.

⁽⁴⁾ **Lead finish/Ball material:** Parts may have multiple material finish options. Finish options are separated by a vertical ruled line. Lead finish/Ball material values may wrap to two lines if the finish value exceeds the maximum column width.

⁽⁵⁾ **MSL rating/Peak reflow:** The moisture sensitivity level ratings and peak solder (reflow) temperatures. In the event that a part has multiple moisture sensitivity ratings, only the lowest level per JEDEC standards is shown. Refer to the shipping label for the actual reflow temperature that will be used to mount the part to the printed circuit board.

⁽⁶⁾ **Part marking:** There may be an additional marking, which relates to the logo, the lot trace code information, or the environmental category of the part.

Multiple part markings will be inside parentheses. Only one part marking contained in parentheses and separated by a "-" will appear on a part. If a line is indented then it is a continuation of the previous line and the two combined represent the entire part marking for that device.

Important Information and Disclaimer: The information provided on this page represents TI's knowledge and belief as of the date that it is provided. TI bases its knowledge and belief on information provided by third parties, and makes no representation or warranty as to the accuracy of such information. Efforts are underway to better integrate information from third parties. TI has taken and continues to take reasonable steps to provide representative and accurate information but may not have conducted destructive testing or chemical analysis on incoming materials and chemicals. TI and TI suppliers consider certain information to be proprietary, and thus CAS numbers and other limited information may not be available for release.

In no event shall TI's liability arising out of such information exceed the total purchase price of the TI part(s) at issue in this document sold by TI to Customer on an annual basis.

TUBE

*All dimensions are nominal

Device	Package Name	Package Type	Pins	SPQ	L (mm)	W (mm)	T (μm)	B (mm)
5962-85155012A	FK	LCCC	20	55	506.98	12.06	2030	NA
5962-8515501SA	W	CFP	20	25	506.98	26.16	6220	NA
5962-85155022A	FK	LCCC	20	55	506.98	12.06	2030	NA
5962-85155032A	FK	LCCC	20	55	506.98	12.06	2030	NA
5962-8515503SA	W	CFP	20	25	506.98	26.16	6220	NA
5962-85155042A	FK	LCCC	20	55	506.98	12.06	2030	NA
5962-8515504SA	W	CFP	20	25	506.98	26.16	6220	NA
TIBPAL16L8-20MFKB	FK	LCCC	20	55	506.98	12.06	2030	NA
TIBPAL16L8-20MFKB.A	FK	LCCC	20	55	506.98	12.06	2030	NA
TIBPAL16L8-20MWB	W	CFP	20	25	506.98	26.16	6220	NA
TIBPAL16L8-20MWB.A	W	CFP	20	25	506.98	26.16	6220	NA
TIBPAL16R4-20MFKB	FK	LCCC	20	55	506.98	12.06	2030	NA
TIBPAL16R4-20MFKB.A	FK	LCCC	20	55	506.98	12.06	2030	NA
TIBPAL16R4-20MWB	W	CFP	20	25	506.98	26.16	6220	NA
TIBPAL16R4-20MWB.A	W	CFP	20	25	506.98	26.16	6220	NA
TIBPAL16R6-20MFKB	FK	LCCC	20	55	506.98	12.06	2030	NA
TIBPAL16R6-20MFKB.A	FK	LCCC	20	55	506.98	12.06	2030	NA
TIBPAL16R6-20MWB	W	CFP	20	25	506.98	26.16	6220	NA
TIBPAL16R6-20MWB.A	W	CFP	20	25	506.98	26.16	6220	NA
TIBPAL16R8-20MFKB	FK	LCCC	20	55	506.98	12.06	2030	NA
TIBPAL16R8-20MFKB.A	FK	LCCC	20	55	506.98	12.06	2030	NA

J (R-GDIP-T**)

14 LEADS SHOWN

CERAMIC DUAL IN-LINE PACKAGE



DIM \ PINS **	14	16	18	20
A	0.300 (7,62) BSC	0.300 (7,62) BSC	0.300 (7,62) BSC	0.300 (7,62) BSC
B MAX	0.785 (19,94)	.840 (21,34)	0.960 (24,38)	1.060 (26,92)
B MIN	—	—	—	—
C MAX	0.300 (7,62)	0.300 (7,62)	0.310 (7,87)	0.300 (7,62)
C MIN	0.245 (6,22)	0.245 (6,22)	0.220 (5,59)	0.245 (6,22)



4040083/F 03/03

- NOTES:
- All linear dimensions are in inches (millimeters).
 - This drawing is subject to change without notice.
 - This package is hermetically sealed with a ceramic lid using glass frit.
 - Index point is provided on cap for terminal identification only on press ceramic glass frit seal only.
 - Falls within MIL STD 1835 GDIP1-T14, GDIP1-T16, GDIP1-T18 and GDIP1-T20.

GENERIC PACKAGE VIEW

FK 20

LCCC - 2.03 mm max height

8.89 x 8.89, 1.27 mm pitch

LEADLESS CERAMIC CHIP CARRIER

This image is a representation of the package family, actual package may vary.
Refer to the product data sheet for package details.



4229370VA\

W (R-GDFP-F20)

CERAMIC DUAL FLATPACK



- NOTES:
- A. All linear dimensions are in inches (millimeters).
 - B. This drawing is subject to change without notice.
 - C. This package can be hermetically sealed with a ceramic lid using glass frit.
 - D. Index point is provided on cap for terminal identification only.
 - E. Falls within Mil-Std 1835 GDFP2-F20

IMPORTANT NOTICE AND DISCLAIMER

TI PROVIDES TECHNICAL AND RELIABILITY DATA (INCLUDING DATASHEETS), DESIGN RESOURCES (INCLUDING REFERENCE DESIGNS), APPLICATION OR OTHER DESIGN ADVICE, WEB TOOLS, SAFETY INFORMATION, AND OTHER RESOURCES "AS IS" AND WITH ALL FAULTS, AND DISCLAIMS ALL WARRANTIES, EXPRESS AND IMPLIED, INCLUDING WITHOUT LIMITATION ANY IMPLIED WARRANTIES OF MERCHANTABILITY, FITNESS FOR A PARTICULAR PURPOSE OR NON-INFRINGEMENT OF THIRD PARTY INTELLECTUAL PROPERTY RIGHTS.

These resources are intended for skilled developers designing with TI products. You are solely responsible for (1) selecting the appropriate TI products for your application, (2) designing, validating and testing your application, and (3) ensuring your application meets applicable standards, and any other safety, security, regulatory or other requirements.

These resources are subject to change without notice. TI grants you permission to use these resources only for development of an application that uses the TI products described in the resource. Other reproduction and display of these resources is prohibited. No license is granted to any other TI intellectual property right or to any third party intellectual property right. TI disclaims responsibility for, and you fully indemnify TI and its representatives against any claims, damages, costs, losses, and liabilities arising out of your use of these resources.

TI's products are provided subject to [TI's Terms of Sale](#), [TI's General Quality Guidelines](#), or other applicable terms available either on [ti.com](#) or provided in conjunction with such TI products. TI's provision of these resources does not expand or otherwise alter TI's applicable warranties or warranty disclaimers for TI products. Unless TI explicitly designates a product as custom or customer-specified, TI products are standard, catalog, general purpose devices.

TI objects to and rejects any additional or different terms you may propose.

Copyright © 2025, Texas Instruments Incorporated

Last updated 10/2025