

TPS40190 4.5-V to 15-V Input, Voltage-Mode, Synchronous Buck Controller

1 Features

- Input Operating Voltage Range: 4.5 V to 15 V
- Reference 0.591 V \pm 1%
- Voltage Mode Control
- Internal 5-V Regulator For Internal Housekeeping, Driver Power and Light External Loads
- Selectable Short-Circuit Protection Thresholds
- Pre-Bias Output Safe
- Fixed Switching Frequency of 300 kHz
- Internal Soft Start
- Small 3 mm \times 3 mm, 10-Pin SON Package
- Bootstrapped Drivers for N-Channel MOSFET
- Adaptive Anti-Cross Conduction
- Internal Bootstrap Diode
- 1.2-A Drivers for Decreased Switching Loss

2 Applications

- Cable modem CPE
- Digital Set Top Box
- Graphics/Audio Cards
- Entry-level and Mid-Range Servers

3 Description

The TPS40190 is a cost-optimized synchronous buck controller that operates from 4.5 V to 15 V nominally, and implements a fixed frequency voltage mode power supply. The controller uses an adaptive anti-cross conduction scheme to prevent both the high-side and the rectifier MOSFET to be turned on at the same time, preventing shoot through current in the two MOSFETs.

The controller also provides a short circuit protection threshold that is user selectable between one of three values. The protection level is set with a single external resistor connected from COMP to GND. During start-up, the impedance connected to COMP is sensed, and the information is decoded to select one of the three thresholds. When the controller senses an output short circuit, both MOSFETs are turned off and a timeout period is observed before attempting to restart. This provides limited power dissipation in the event of a sustained fault.

The TPS40190 provides strong drivers to minimize switching losses in the power stage, reducing heat build up in the MOSFETs and allowing larger MOSFETs to be used without undue switching time penalty.

Device Information⁽¹⁾

PART NUMBER	PACKAGE	BODY SIZE (NOM)
TPS40190	VSON (10)	3.00 mm \times 3.00 mm

(1) For all available packages, see the orderable addendum at the end of the data sheet.

Simplified Application Diagram

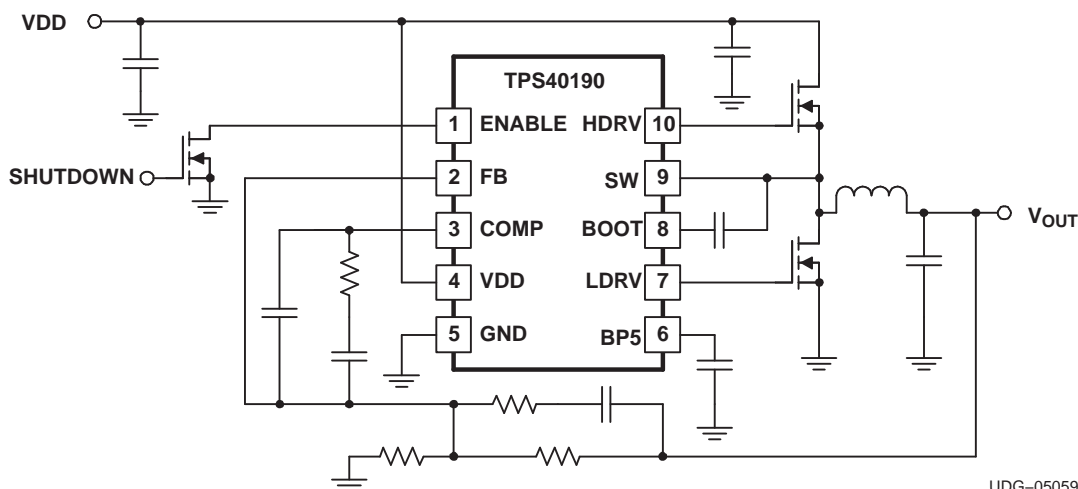

Table of Contents

1 Features 1 2 Applications 1 3 Description 1 4 Revision History 2 5 Pin Configuration and Functions 3 6 Specifications 4 6.1 Absolute Maximum Ratings 4 6.2 Dissipation Ratings 4 6.3 Recommended Operating Conditions 4 6.4 Electrical Characteristics 5 6.5 Typical Characteristics 7 7 Detailed Description 11 7.1 Overview 11	7.2 Functional Block Diagram 11 7.3 Feature Description 11 8 Application and Implementation 17 8.1 Typical Applications 17 9 Device and Documentation Support 20 9.1 Documentation Support 20 9.2 Receiving Notification of Documentation Updates.. 20 9.3 Community Resources..... 20 9.4 Trademarks 20 9.5 Electrostatic Discharge Caution 20 9.6 Glossary 20 10 Mechanical, Packaging, and Orderable Information 20
---	--

4 Revision History

NOTE: Page numbers for previous revisions may differ from page numbers in the current version.

Changes from Revision C (July 2012) to Revision D	Page
• Editorial changes only, no technical revisions.....	1
• Added <i>Feature Description</i> section, <i>Device Functional Modes</i> , <i>Application and Implementation</i> section, <i>Power Supply Recommendations</i> section, <i>Layout</i> section, <i>Device and Documentation Support</i> section, and <i>Mechanical, Packaging, and Orderable Information</i> section	1
• Deleted Ordering Information table	3

Changes from Revision B (August 2007) to Revision C	Page
• Added a new paragraph to the end of the Enable Functionality section.....	14

5 Pin Configuration and Functions

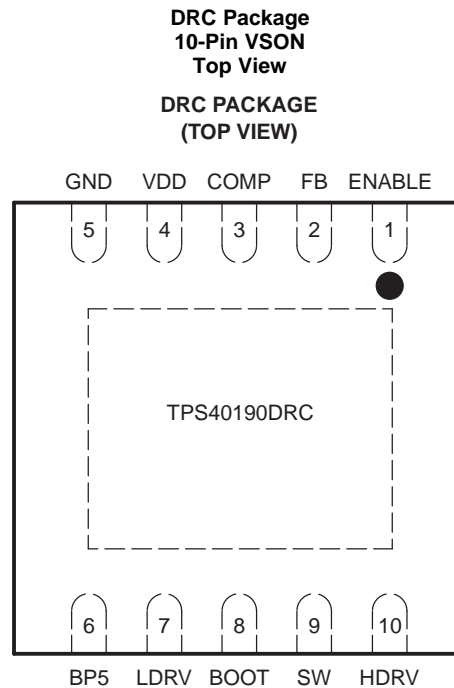

Pin Functions

PIN		I/O	DESCRIPTION
NO.	NAME		
1	ENABLE	I	Logic level input that starts or stops the controller from an external user command. A high level turns the controller on. This pin has a high-impedance internal pull-up integrated into the device. Because this pin is high impedance, a 10-nF capacitor to ground or an external pull-up resistor (100 kΩ) to VDD is recommended to avoid noise coupling to this pin.
2	FB	I	Inverting input to the error amplifier
3	COMP	O	Output of the error amplifier. Connecting a resistance from COMP to GND sets the output short circuit detection threshold. See applications information for details.
4	VDD	I	Power input to the controller
5	GND	—	Common connection for the controller
6	BP5	O	Output bypass for the internal regulator. Connect 4.7-μF capacitor from this pin to GND. Low power, low noise loads may be connected here if desired. The sum of the external load and the gate drive requirements must not exceed 40 mA. The regulator is turned off when the ENABLE pin is pulled low.
7	LDRV	O	Output to the rectifier FET gate
8	BOOT	I	Power supply for the flying high-side driver
9	SW	I	Sense line for the adaptive anti cross conduction circuitry. Serves as common connection for the flying high side FET driver
10	HDRV	O	Bootstrapped output for driving the gate of the high side N channel FET.

6 Specifications

6.1 Absolute Maximum Ratings

over operating free-air temperature range (unless otherwise noted)⁽¹⁾

		MIN	MAX	UNIT
Input voltage range	VDD	-0.3	16.5	V
	SW	-5	22	
	BOOT-SW, HDRV-SW (differential from BOOT or HDRV to SW)	-0.3	6	
	COMP	-0.3	3	
	FB, BP5, LDRV, ENABLE	-0.3	6	
Operating junction temperature, T _J		-40	125	°C
Storage temperature, T _{stg}		-55	150	°C

- (1) Stresses beyond those listed under *Absolute Maximum Ratings* may cause permanent damage to the device. These are stress ratings only, which do not imply functional operation of the device at these or any other conditions beyond those indicated under *Recommended Operating Conditions*. Exposure to absolute-maximum-rated conditions for extended periods may affect device reliability.

6.2 Dissipation Ratings

PACKAGE	R _{θJA} High-K Board ⁽¹⁾ (°C/W)	R _{θJC} ⁽²⁾ (°C/W)
DRC	47.9	14.1

- (1) The JEDEC High-K (2s2p) board design used to derive this data was a 3-inch x 3-inch (7.5-cm x 7.5-cm), multilayer board with one-ounce internal power and ground planes and two-ounce copper traces on top and bottom of the board.
- (2) The junction-to-case impedance is measured from the die to the thermal pad on the device package.

6.3 Recommended Operating Conditions

		MIN	NOM	MAX	UNIT
V _{DD}	Input voltage	4.5		15	V
T _A	Operating free-air temperature	-40		85	°C

6.4 Electrical Characteristics

 $T_A = -40^{\circ}\text{C}$ to 85°C , $V_{\text{VDD}} = 12 V_{\text{dc}}$, $T_A = T_J$, and all parameters at zero power dissipation (unless otherwise noted)

PARAMETER		TEST CONDITIONS	MIN	TYP	MAX	UNIT
V_{FB}	Feedback voltage range	$0^{\circ}\text{C} \leq T_J \leq 85^{\circ}\text{C}$	585	591	597	mV
		$-40^{\circ}\text{C} \leq T_J \leq 85^{\circ}\text{C}$	582	591	597	
INPUT SUPPLY						
V_{VDD}	Input voltage range		4.5		15.0	V
I_{VDD}	Operating current	$V_{\text{ENABLE}} = 2.5 \text{ V}$, Outputs switching			2.5	mA
		$V_{\text{ENABLE}} = 0.6 \text{ V}$			20	μA
ON BOARD REGULATOR						
V_{5VBP}	Output voltage	$V_{\text{VDD}} > 6 \text{ V}$, $I_{\text{5VBP}} \leq 10 \text{ mA}$	5.1	5.3	5.5	V
V_{DO}	Regulator dropout voltage	$V_{\text{VDD}} - V_{\text{BP5}}$, $V_{\text{VDD}} = 5 \text{ V}$, $I_{\text{BP5}} \leq 25 \text{ mA}$		270	400	mV
I_{SC}	Regulator current limit threshold		40			mA
I_{BP5}	Average current ⁽¹⁾				40	
OSCILLATOR						
f_{SW}	Switching frequency		240	300	360	kHz
V_{RMP}	Ramp amplitude ⁽²⁾			0.75		V
V_{VALLEY}	Valley voltage ⁽²⁾			0.5		V
PWM						
D_{MAX}	Maximum duty cycle ⁽²⁾		85%			
$t_{\text{ON(min)}}$	Minimum controlled pulse ⁽²⁾				130	ns
t_{DEAD}	Output driver dead time	HDRV off to LDRV on		50		ns
		LDRV off to HDRV on		25		
SOFT-START						
t_{SS}	Soft-start time		3.0	4.7	7.0	ms
t_{SSDLY}	Soft-start delay time ⁽³⁾			6		ms
t_{REG}	Time to regulation			10.5		ms
ERROR AMPLIFIER						
GBWP	Gain bandwidth product ⁽²⁾		5			MHz
A_{OL}	DC gain ⁽²⁾		60			dB
I_{IB}	Input bias current (current out of FB pin)		100		0	nA
I_{EAOP}	Output source current	$V_{\text{FB}} = 0 \text{ V}$	1			mA
I_{EAOM}	Output sink current	$V_{\text{FB}} = 2 \text{ V}$	1			mA
SHORT CIRCUIT PROTECTION						
$t_{\text{PSS(min)}}$	Minimum pulse during short circuit ⁽²⁾				250	ns
t_{BLNK}	Blanking time ⁽²⁾		100	140	180	ns
t_{OFF}	Off-time between restart attempts		25	95		ms
V_{ILIM}	Short circuit comparator threshold voltage	$R_{\text{COMP(GND)}} = \text{OPEN}$, $T_J = 25^{\circ}\text{C}$	256	320	384	mV
		$R_{\text{COMP(GND)}} = 4 \text{ k}\Omega$, $T_J = 25^{\circ}\text{C}$	128	160	192	
		$R_{\text{COMP(GND)}} = 12 \text{ k}\Omega$, $T_J = 25^{\circ}\text{C}$	368	460	552	

(1) 40 mA is the current available for MOSFET gate drive, the device itself and any external loads. The sum of these must not exceed 40 mA.

(2) Specified by design. Not production tested.

(3) The delay time is the time delay from application of power to the device or from assertion of ENABLE until the output begins to rise.

Electrical Characteristics (continued)
 $T_A = -40^{\circ}\text{C}$ to 85°C , $V_{\text{VDD}} = 12 V_{\text{dc}}$, $T_A = T_J$, and all parameters at zero power dissipation (unless otherwise noted)

PARAMETER		TEST CONDITIONS	MIN	TYP	MAX	UNIT
OUTPUT DRIVERS						
R_{HDHI}	High-side driver pull-up resistance	$V_{\text{BOOT}} - V_{\text{SW}} = 4.5 \text{ V}$, $I_{\text{HDRV}} = -100 \text{ mA}$		3	6	Ω
R_{HDLO}	High-side driver pull-down resistance	$V_{\text{BOOT}} - V_{\text{SW}} = 4.5 \text{ V}$, $I_{\text{HDRV}} = 100 \text{ mA}$		1.5	3	Ω
R_{LDHI}	Low-side driver pull-up resistance	$I_{\text{LDRV}} = -100 \text{ mA}$		2.5	5	Ω
R_{LDLO}	Low-side driver pull-down resistance	$I_{\text{LDRV}} = 100 \text{ mA}$		0.8	1.5	Ω
t_{HRISE}	High-side driver rise time ⁽²⁾	$C_{\text{LOAD}} = 1 \text{ nF}$		15	35	ns
$t_{\text{H FALL}}$	High-side driver fall time ⁽²⁾	$C_{\text{LOAD}} = 1 \text{ nF}$		10	25	ns
t_{LRISE}	Low-side driver rise time ⁽²⁾	$C_{\text{LOAD}} = 1 \text{ nF}$		15	35	ns
$t_{\text{L FALL}}$	Low-side driver fall time ⁽²⁾	$C_{\text{LOAD}} = 1 \text{ nF}$		10	25	ns
UNDERVOLTAGE LOCKOUT (UVLO)						
V_{UVLO}	Turn-on voltage		4.1	4.25	4.4	V
$\text{UVLO}_{\text{HYST}}$	Hysteresis		270	320	370	mV
SHUTDOWN						
V_{IH}	High-level input voltage	ENABLE			2.8	V
V_{IL}	Low-level input voltage	ENABLE	0.6			V
BOOT DIODE						
V_{DFWD}	Bootstrap diode forward voltage	$I_{\text{BOOT}} = 5 \text{ mA}$	0.6	0.8	1.2	V

6.5 Typical Characteristics

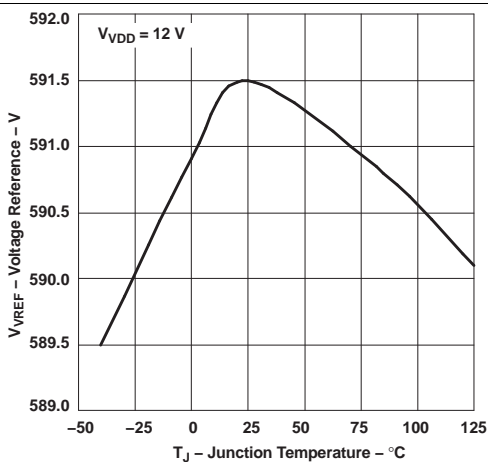

Figure 1. Reference Voltage vs Temperature

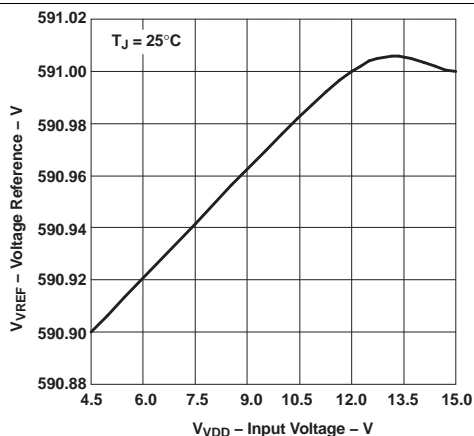

Figure 2. Reference Voltage vs Input Voltage

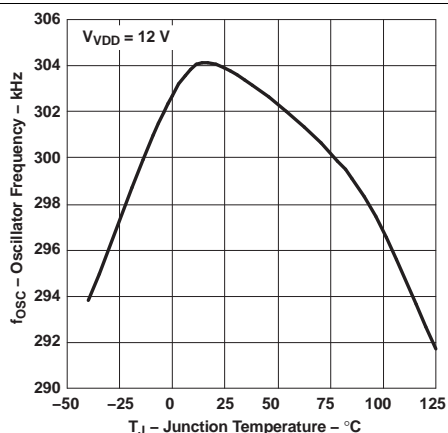

Figure 3. Oscillator Frequency vs Temperature

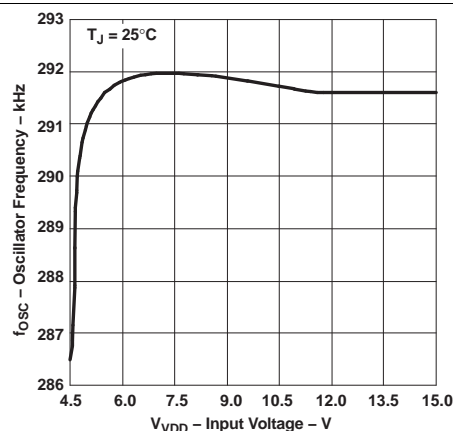

Figure 4. Oscillator Frequency vs Input Voltage

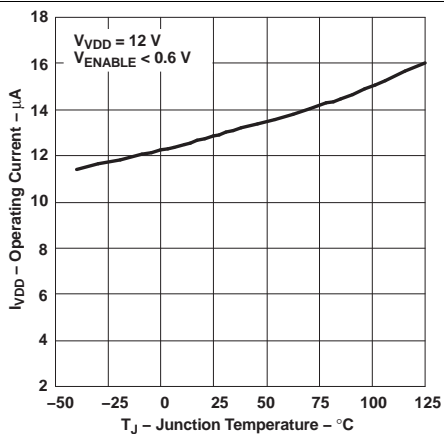

Figure 5. Operating Current vs Temperature

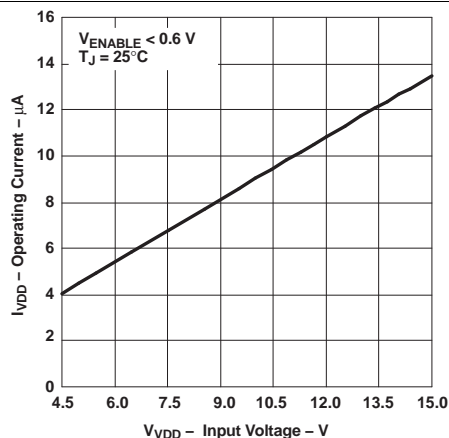

Figure 6. Operating Current vs Input Voltage

Typical Characteristics (continued)

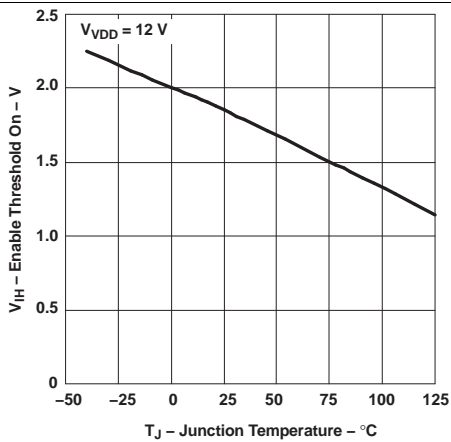

Figure 7. Enable Threshold On vs Temperature

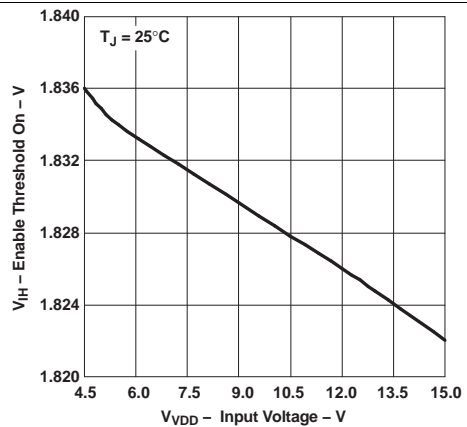

Figure 8. Enable Threshold On vs Input Voltage

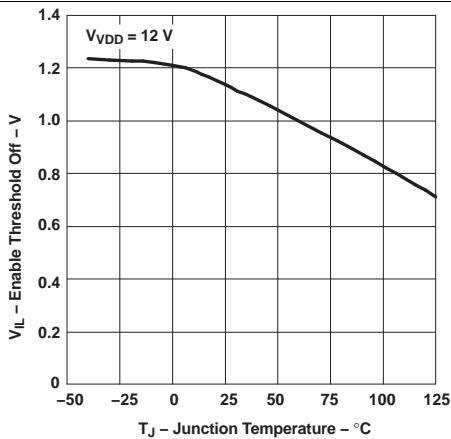

Figure 9. Enable Threshold Off vs Temperature

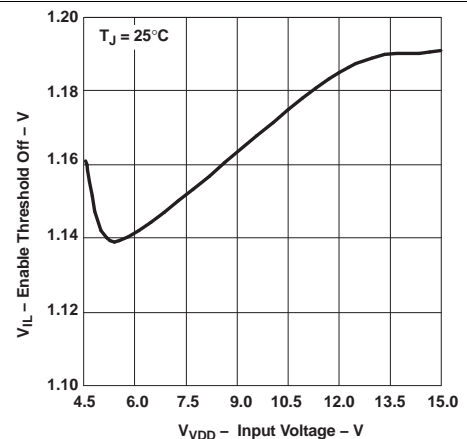

Figure 10. Enable Threshold Off vs Input Voltage

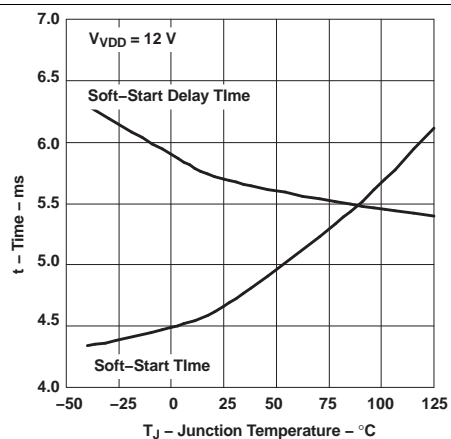

Figure 11. Soft Start Timing vs Temperature

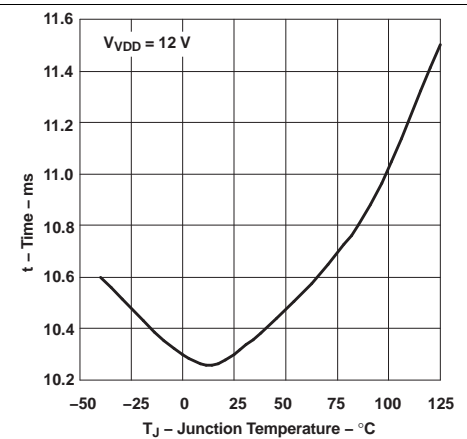

Figure 12. Total Startup Time vs Temperature

Typical Characteristics (continued)

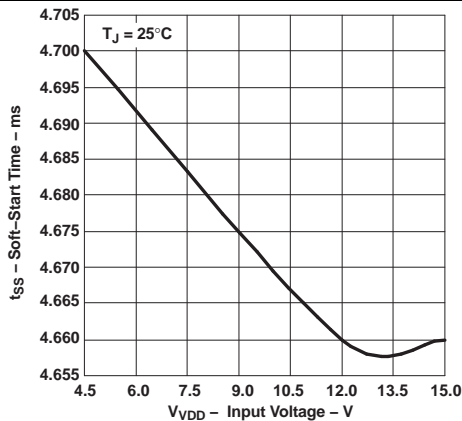

Figure 13. Soft Start Timing vs Input Voltage

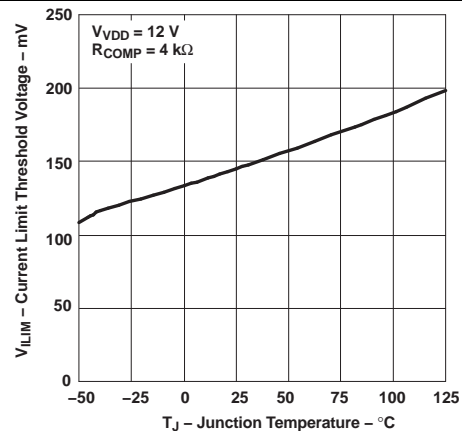

Figure 14. Current Limit Threshold vs Temperature

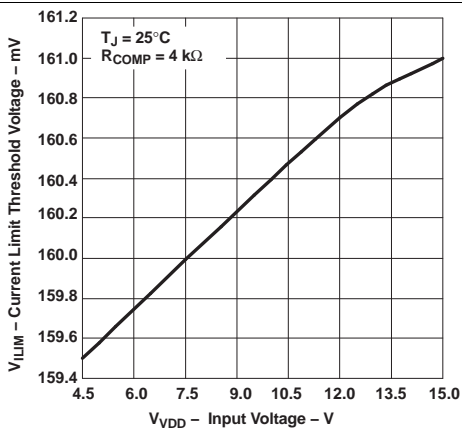

Figure 15. Current Limit Threshold vs Input Voltage

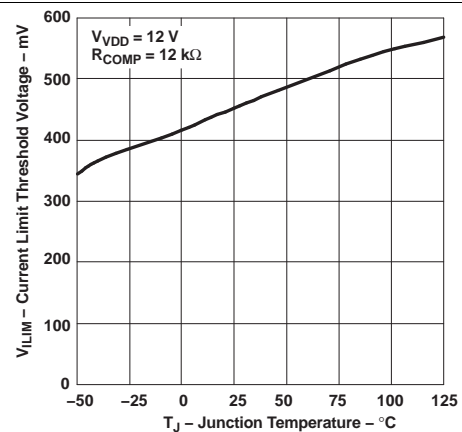

Figure 16. Current Limit Threshold vs Temperature

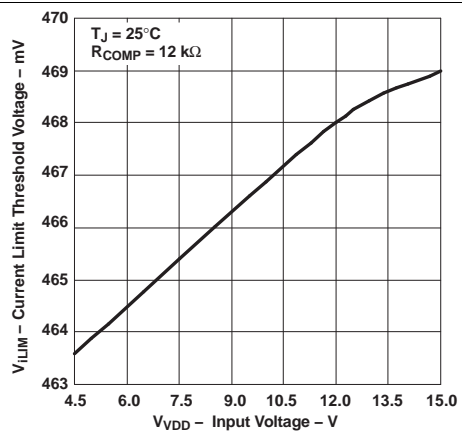

Figure 17. Current Limit Threshold vs Input Voltage

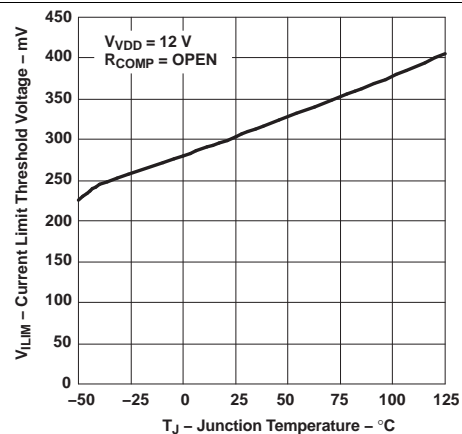

Figure 18. Current Limit Threshold vs Temperature

Typical Characteristics (continued)

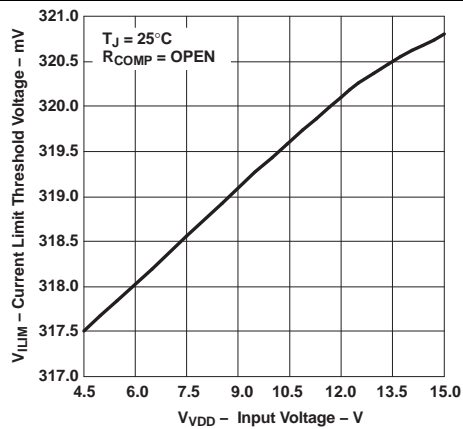

Figure 19. Current Limit Threshold vs Input Voltage

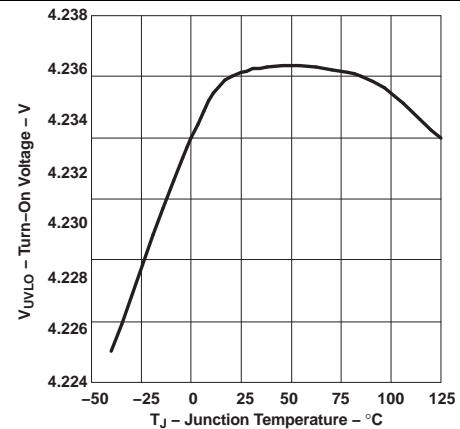

Figure 20. Undervoltage Lockout Turn On Voltage vs Temperature

Feature Description (continued)

7.3.2 Output Short Circuit Protection

The short circuit detection in the TPS40190 is done by sensing the voltage drop across the high side FET when it is on. If the voltage drop across this FET exceeds the selected threshold in any given switching cycle, a counter counts up one count and the FET is turned off early. If the voltage drop across that FET does not exceed this threshold, the counter is decremented for that cycle and the FET is allowed to remain on for the normal pulse width commanded by the internal pulse width modulator. If the counter fills up (a count of 7) a fault condition is declared and the drivers turn both FETs off. After a timeout of approximately 95 ms, the controller attempts to restart. If a short circuit is still present at the output, the current ramps quickly up to the short-circuit threshold and another fault condition is declared. The device then waits 95 ms to attempt to restart again.

Typical waveforms during a short circuit event are shown in [Figure 21](#) and [Figure 22](#).

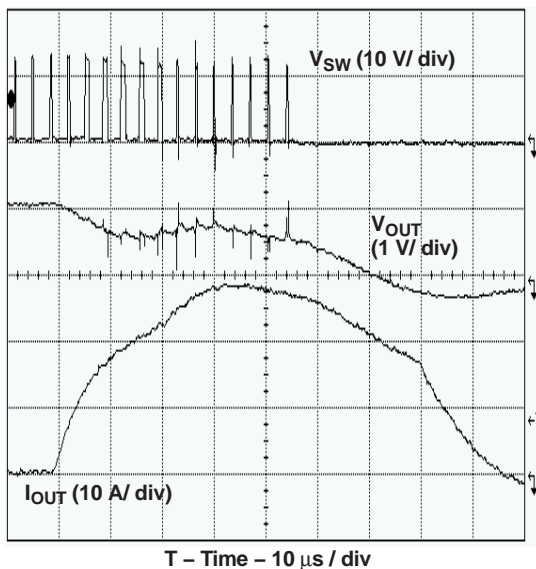

Figure 21. Output Short Circuit Detected (Nominal Threshold 25 A)

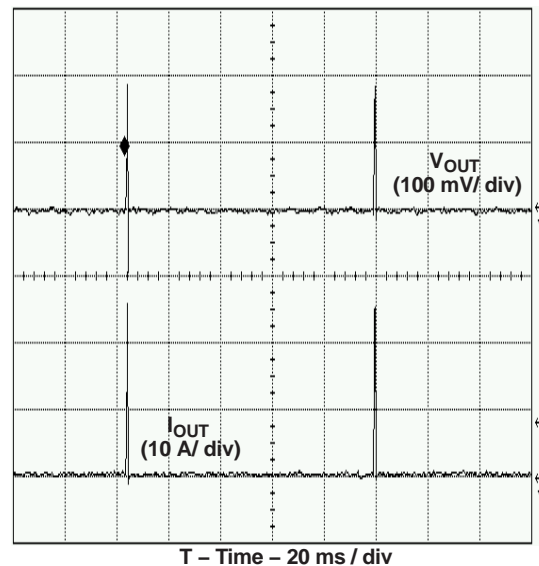

Figure 22. Output Fault Hiccup Restart Timing

The TPS40190 provides three selectable short circuit protection thresholds: 160 mV, 320 mV and 460 mV. The particular threshold is selected by connecting a resistor from COMP to GND. [Table 1](#) gives the short circuit thresholds for corresponding resistors from COMP to GND. Note that since the TPS40190 measures the resistance from COMP to GND during a 2-ms window, the compensation network from COMP to FB should have a time constant significantly less than 1 ms or there can be issues detecting the resistance and setting the correct short circuit threshold. This network should have no DC path from COMP to FB.

The short circuit detection threshold in the TPS40190 has some temperature compensation built in to help offset the high-side FET rise in resistance as its temperature rises. A typical FET has a resistance temperature coefficient of about 4500 ppm/°C. The temperature coefficient of the short circuit threshold is approximately 4200 ppm/°C. [Figure 23](#) shows how the short circuit threshold increases with temperature to help compensate for the FET resistance increase. The relative FET resistance change is based on an estimate of a linear 4500 ppm/°C temperature coefficient. The effectiveness of this compensation depends on how tight the thermal coupling between the TPS40190 and the high-side FET is. Better thermal coupling between the TPS40190 and the high-side FET gives better compensation effectiveness.

Feature Description (continued)

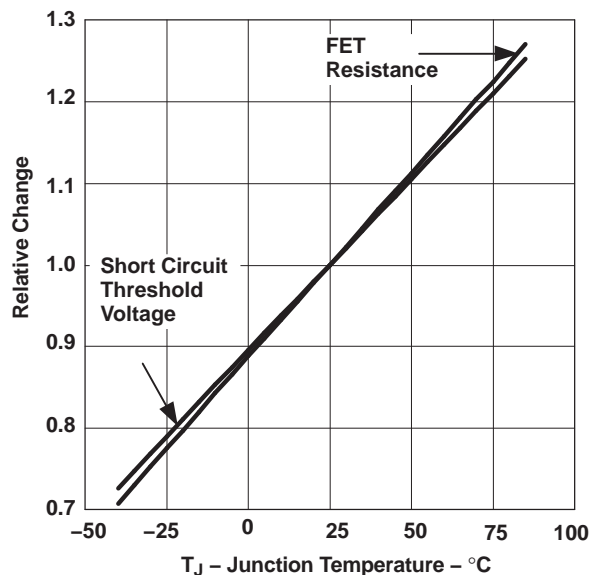

Figure 23. Relative Short Circuit Threshold Change vs Temperature

Table 1. Short Circuit Threshold Voltage Selection

SHORT CIRCUIT PROTECTION RESISTANCE, R _{COMP} (kΩ)	NOMINAL CURRENT LIMIT VOLTAGE, V _{ILIM} (mV)
10.8 to 13.2	460
OPEN	320
3.6 to 4.4	160

The range of short circuit current thresholds that can be expected is given by Equation 1 and Equation 2.

$$I_{SCP(max)} = \frac{V_{ILIM(max)}}{R_{DS(onMIN)}} \tag{1}$$

$$I_{SCP(min)} = \frac{V_{ILIM(min)}}{R_{DS(onMAX)}}$$

where

- I_{SCP} is the short circuit current
 - V_{ILIM} is the short circuit threshold
 - R_{DS(on)} is the channel resistance of the high-side MOSFET
- (2)

7.3.3 Enable Functionality

The TPS40190 has a dedicated ENABLE pin. This simplifies user level interface design since no multiplexed functions exist. Another benefit is a true low power shutdown mode of operation. In this state, the BP5 regulator is turned off. When the ENABLE pin is pulled to GND, the TPS40190 consumes a typical 20-μA of current. A functionally equivalent circuit to the enable circuitry on the TPS40190 is shown in Figure 24.

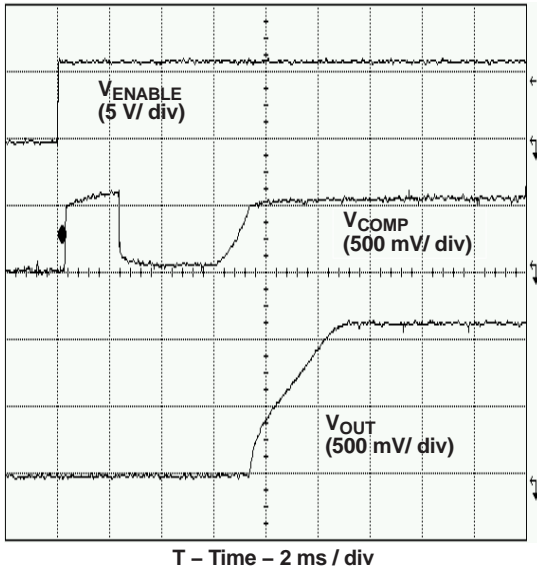

Figure 25. Startup Using ENABLE Pin

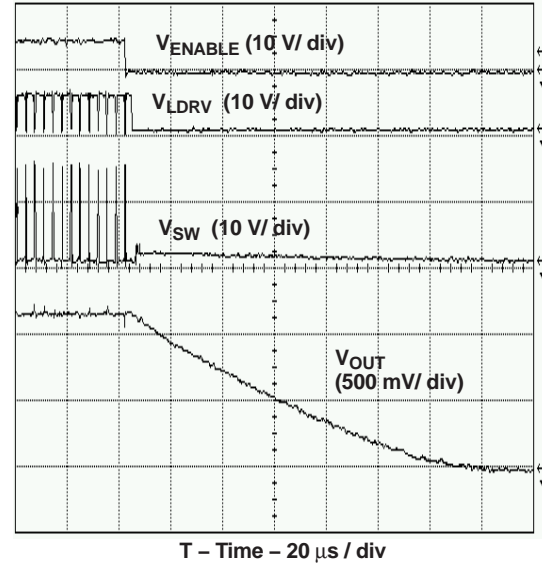

Figure 26. Shutdown Using ENABLE Pin

7.3.4 5-V Regulator

The TPS40190 has an on board 5-V regulator that allows the part to operate from a single voltage feed. No separate 5-V feed to the part is required. This regulator needs to have 4.7- μ F of capacitance on the BP5 pin for stability. A ceramic capacitor is suggested for this purpose.

This regulator can also be used to supply power to nearby circuitry, eliminating the need for a separate LDO in some cases. If this pin is used for external loads, keep in mind that this is the power supply for the internals of the TPS40190. While efforts have been made to reduce sensitivity, any noise induced on this line has an adverse effect on the overall performance of the internal circuitry and shows up as increased pulse jitter, or skewed reference voltage. This regulator is turned off when the ENABLE pin is pulled low.

The amount of power available from this pin varies with the size of the power MOSFETs that the drivers must operate. Larger MOSFETs require more gate drive current and reduces the amount of power available on this pin for other tasks.

The total amount of current required by the gate drive and the external circuitry should not exceed 40 mA. The current required to drive the FET gates can be found from [Equation 3](#).

$$I_G = f_{SW} \times (Q_{G(\text{high})} + Q_{G(\text{low})})$$

Where

- I_G is the required gate drive current
 - f_{SW} is the switching frequency (300 kHz)
 - $Q_{G(\text{high})}$ is the gate charge requirement for the high-side FET at 5 V V_{GS}
 - $Q_{G(\text{low})}$ is the gate charge requirement for the low-side FET at 5 V V_{GS}
- (3)

7.3.5 Startup Sequence and Timing

The TPS40190 startup sequence is as follows. After input power is applied, the 5-V onboard regulator comes up. Once this regulator comes up, the TPS40190 goes through a period where it samples the impedance at the COMP pin and decides the short circuit protection threshold voltage. This is accomplished by placing 400 mV on the COMP pin for approximately 2 ms. During this time, the current is measured and compared against internal thresholds to select the short circuit protection threshold. After this, the COMP pin is brought low for 4 ms. This ensures that the feedback loop is preconditioned at startup and no sudden output rise occurs at the output of the converter when the converter is allowed to start switching. After these initial 6 milliseconds, the internal soft-start circuitry is engaged and the converter is allowed to start. See [Figure 27](#).

7.3.6 Prebias Outputs

Some applications require that the converter not sink current during start-up if a pre-existing voltage is higher than the output. Because synchronous buck converters inherently sink current some method of overcoming this characteristic must be employed. Applications that require this operation are typically power rails for a multi supply processor or ASIC. The method used in this controller, is to not allow the low side or rectifier FET to turn on until there the output voltage commanded by the start up ramp is higher than the pre-existing output voltage. This is detected by monitoring the internal pulse width modulator (PWM) for its first output pulse. Because this controller uses a closed loop startup, the first output pulse from the PWM does not occur until the output voltage is commanded to be higher than the pre-existing voltage. This effectively limits the controller to sourcing current only during the startup sequence.

If the pre-existing voltage is higher than the intended regulation point for the output of the converter, the converter starts and sinks current when the soft-start time has completed. A typical pre-biased start-up is shown in Figure 28.

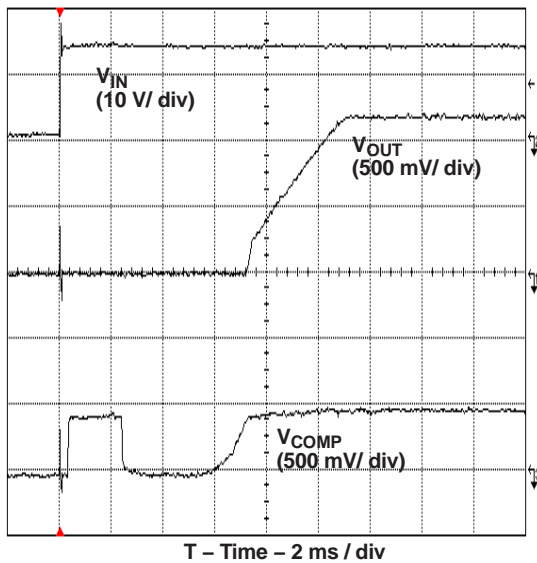

Figure 27. TPS40190 Start-up Timing

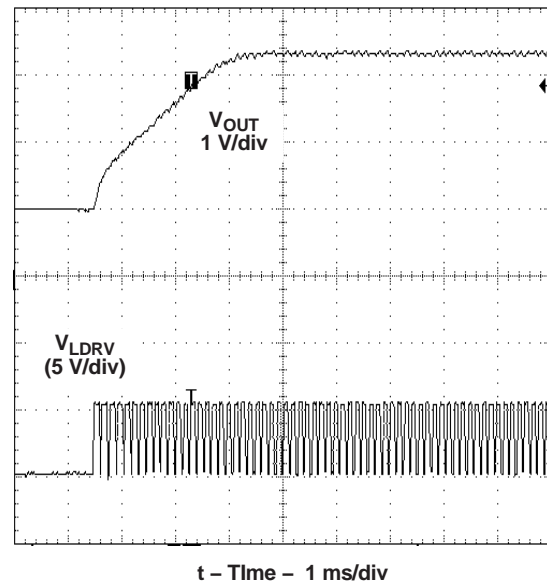

Figure 28. Prebiased Start-up Timing

8 Application and Implementation

NOTE

Information in the following applications sections is not part of the TI component specification, and TI does not warrant its accuracy or completeness. TI's customers are responsible for determining suitability of components for their purposes. Customers should validate and test their design implementation to confirm system functionality.

8.1 Typical Applications

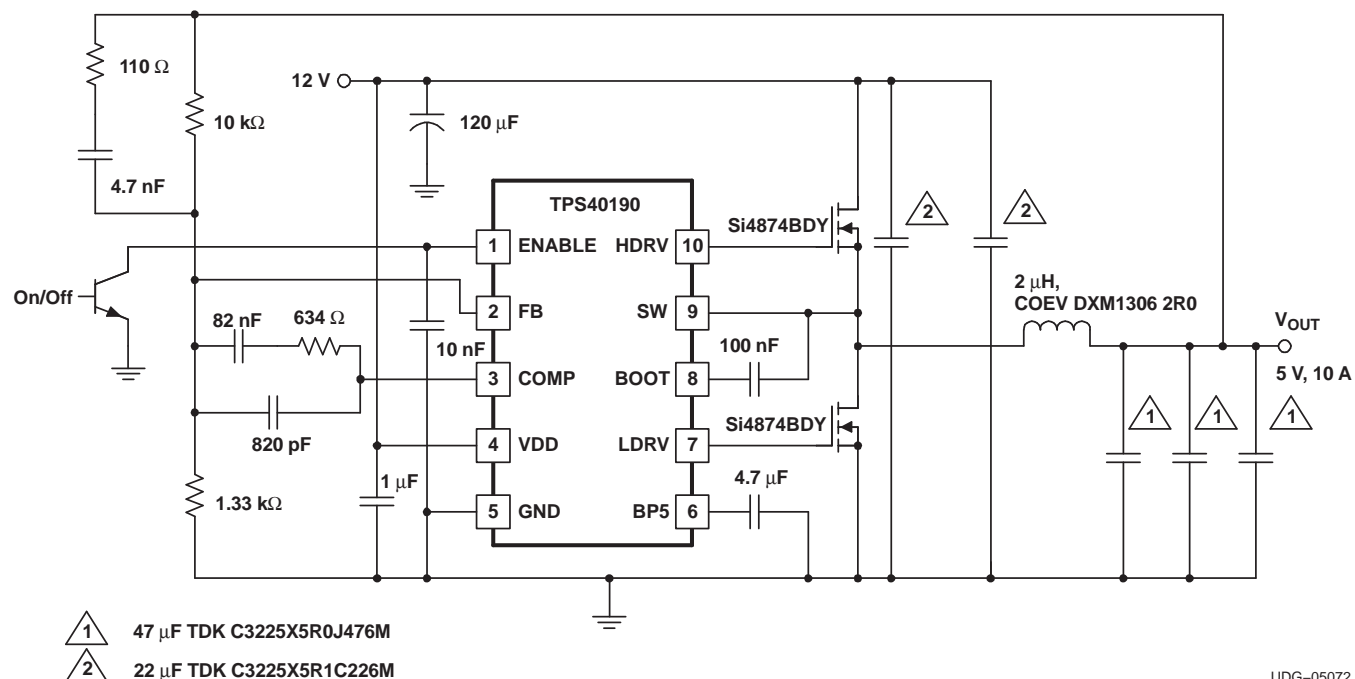

UDG-05072

Figure 29. 12-V to 5-V at 10 A

Typical Applications (continued)

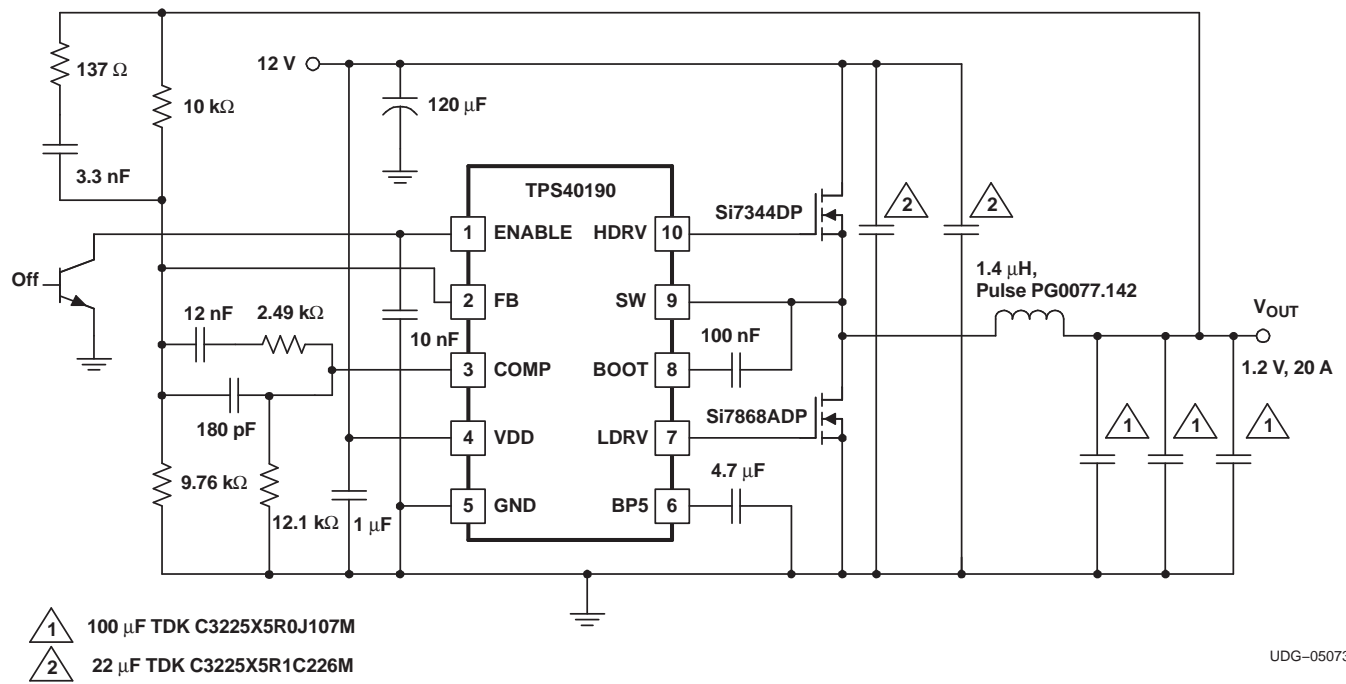

UDG-05073

Figure 30. 12-V to 1.2-V at 20 A

Typical Applications (continued)

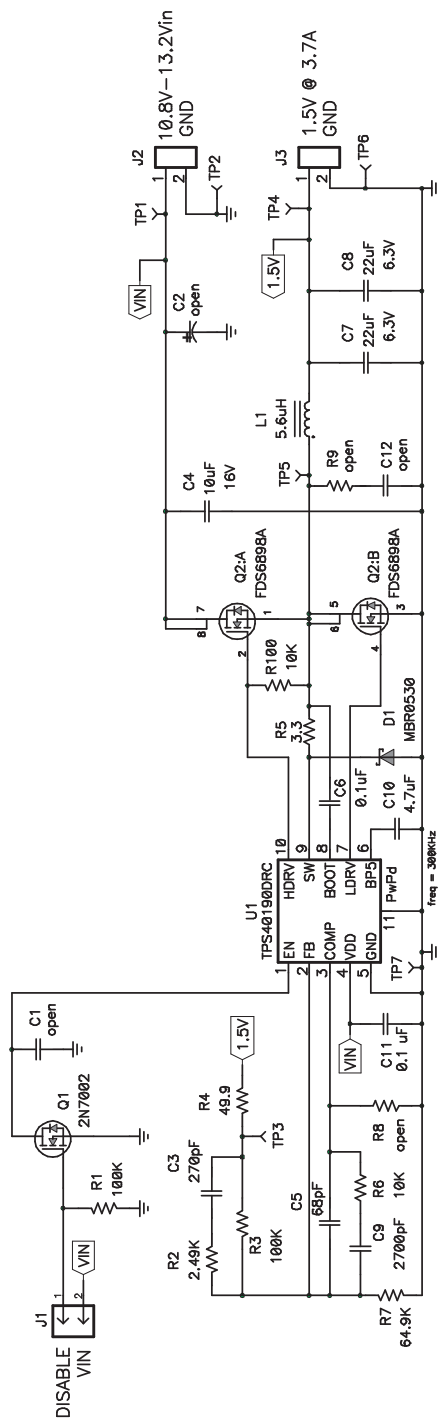

Figure 31. PMP1285, 12-V to 1.5-V, at 3.7 A

9 Device and Documentation Support

9.1 Documentation Support

9.1.1 Related Documentation

For related documentation see the following:

- TI Application Report, *Enabling Multiple TPS4019x Devices*, [SLVA509](#)

9.2 Receiving Notification of Documentation Updates

To receive notification of documentation updates, navigate to the device product folder on ti.com. In the upper right corner, click on *Alert me* to register and receive a weekly digest of any product information that has changed. For change details, review the revision history included in any revised document.

9.3 Community Resources

The following links connect to TI community resources. Linked contents are provided "AS IS" by the respective contributors. They do not constitute TI specifications and do not necessarily reflect TI's views; see TI's [Terms of Use](#).

TI E2E™ Online Community *TI's Engineer-to-Engineer (E2E) Community*. Created to foster collaboration among engineers. At e2e.ti.com, you can ask questions, share knowledge, explore ideas and help solve problems with fellow engineers.

Design Support *TI's Design Support* Quickly find helpful E2E forums along with design support tools and contact information for technical support.

9.4 Trademarks

E2E is a trademark of Texas Instruments.

All other trademarks are the property of their respective owners.

9.5 Electrostatic Discharge Caution



These devices have limited built-in ESD protection. The leads should be shorted together or the device placed in conductive foam during storage or handling to prevent electrostatic damage to the MOS gates.

9.6 Glossary

[SLYZ022](#) — *TI Glossary*.

This glossary lists and explains terms, acronyms, and definitions.

10 Mechanical, Packaging, and Orderable Information

The following pages include mechanical, packaging, and orderable information. This information is the most current data available for the designated devices. This data is subject to change without notice and revision of this document. For browser-based versions of this data sheet, refer to the left-hand navigation.

PACKAGING INFORMATION

Orderable Device	Status (1)	Package Type	Package Drawing	Pins	Package Qty	Eco Plan (2)	Lead finish/ Ball material (6)	MSL Peak Temp (3)	Op Temp (°C)	Device Marking (4/5)	Samples
TPS40190DRCR	ACTIVE	VSON	DRC	10	3000	RoHS & Green	NIPDAU NIPDAUAG	Level-2-260C-1 YEAR	-40 to 85	0190	Samples
TPS40190DRCRG4	ACTIVE	VSON	DRC	10	3000	RoHS & Green	NIPDAU	Level-2-260C-1 YEAR	-40 to 85	0190	Samples
TPS40190DRCT	ACTIVE	VSON	DRC	10	250	RoHS & Green	NIPDAU	Level-1-260C-UNLIM	-40 to 85	0190	Samples
TPS40190DRCTG4	ACTIVE	VSON	DRC	10	250	RoHS & Green	NIPDAU	Level-1-260C-UNLIM	-40 to 85	0190	Samples

(1) The marketing status values are defined as follows:

ACTIVE: Product device recommended for new designs.

LIFEBUY: TI has announced that the device will be discontinued, and a lifetime-buy period is in effect.

NRND: Not recommended for new designs. Device is in production to support existing customers, but TI does not recommend using this part in a new design.

PREVIEW: Device has been announced but is not in production. Samples may or may not be available.

OBSELETE: TI has discontinued the production of the device.

(2) **RoHS:** TI defines "RoHS" to mean semiconductor products that are compliant with the current EU RoHS requirements for all 10 RoHS substances, including the requirement that RoHS substance do not exceed 0.1% by weight in homogeneous materials. Where designed to be soldered at high temperatures, "RoHS" products are suitable for use in specified lead-free processes. TI may reference these types of products as "Pb-Free".

RoHS Exempt: TI defines "RoHS Exempt" to mean products that contain lead but are compliant with EU RoHS pursuant to a specific EU RoHS exemption.

Green: TI defines "Green" to mean the content of Chlorine (Cl) and Bromine (Br) based flame retardants meet JS709B low halogen requirements of <=1000ppm threshold. Antimony trioxide based flame retardants must also meet the <=1000ppm threshold requirement.

(3) MSL, Peak Temp. - The Moisture Sensitivity Level rating according to the JEDEC industry standard classifications, and peak solder temperature.

(4) There may be additional marking, which relates to the logo, the lot trace code information, or the environmental category on the device.

(5) Multiple Device Markings will be inside parentheses. Only one Device Marking contained in parentheses and separated by a "-" will appear on a device. If a line is indented then it is a continuation of the previous line and the two combined represent the entire Device Marking for that device.

(6) Lead finish/Ball material - Orderable Devices may have multiple material finish options. Finish options are separated by a vertical ruled line. Lead finish/Ball material values may wrap to two lines if the finish value exceeds the maximum column width.

Important Information and Disclaimer:The information provided on this page represents TI's knowledge and belief as of the date that it is provided. TI bases its knowledge and belief on information provided by third parties, and makes no representation or warranty as to the accuracy of such information. Efforts are underway to better integrate information from third parties. TI has taken and

continues to take reasonable steps to provide representative and accurate information but may not have conducted destructive testing or chemical analysis on incoming materials and chemicals. TI and TI suppliers consider certain information to be proprietary, and thus CAS numbers and other limited information may not be available for release.

In no event shall TI's liability arising out of such information exceed the total purchase price of the TI part(s) at issue in this document sold by TI to Customer on an annual basis.

TAPE AND REEL INFORMATION

QUADRANT ASSIGNMENTS FOR PIN 1 ORIENTATION IN TAPE

*All dimensions are nominal

Device	Package Type	Package Drawing	Pins	SPQ	Reel Diameter (mm)	Reel Width W1 (mm)	A0 (mm)	B0 (mm)	K0 (mm)	P1 (mm)	W (mm)	Pin1 Quadrant
TPS40190DRCR	VSON	DRC	10	3000	330.0	12.4	3.3	3.3	1.1	8.0	12.0	Q2
TPS40190DRCT	VSON	DRC	10	250	180.0	12.4	3.3	3.3	1.1	8.0	12.0	Q2

TAPE AND REEL BOX DIMENSIONS

*All dimensions are nominal

Device	Package Type	Package Drawing	Pins	SPQ	Length (mm)	Width (mm)	Height (mm)
TPS40190DRCR	VSON	DRC	10	3000	346.0	346.0	33.0
TPS40190DRCT	VSON	DRC	10	250	182.0	182.0	20.0

GENERIC PACKAGE VIEW

DRC 10

VSON - 1 mm max height

3 x 3, 0.5 mm pitch

PLASTIC SMALL OUTLINE - NO LEAD

This image is a representation of the package family, actual package may vary.
Refer to the product data sheet for package details.



4226193/A

EXAMPLE BOARD LAYOUT

DRC0010J

VSON - 1 mm max height

PLASTIC SMALL OUTLINE - NO LEAD



LAND PATTERN EXAMPLE
EXPOSED METAL SHOWN
SCALE:20X



SOLDER MASK DETAILS

4218878/B 07/2018

NOTES: (continued)

4. This package is designed to be soldered to a thermal pad on the board. For more information, see Texas Instruments literature number SLUA271 (www.ti.com/lit/sluea271).
5. Vias are optional depending on application, refer to device data sheet. If any vias are implemented, refer to their locations shown on this view. It is recommended that vias under paste be filled, plugged or tented.

EXAMPLE STENCIL DESIGN

DRC0010J

VSON - 1 mm max height

PLASTIC SMALL OUTLINE - NO LEAD



SOLDER PASTE EXAMPLE
BASED ON 0.125 mm THICK STENCIL

EXPOSED PAD 11:
80% PRINTED SOLDER COVERAGE BY AREA
SCALE:25X

4218878/B 07/2018

NOTES: (continued)

6. Laser cutting apertures with trapezoidal walls and rounded corners may offer better paste release. IPC-7525 may have alternate design recommendations.

IMPORTANT NOTICE AND DISCLAIMER

TI PROVIDES TECHNICAL AND RELIABILITY DATA (INCLUDING DATA SHEETS), DESIGN RESOURCES (INCLUDING REFERENCE DESIGNS), APPLICATION OR OTHER DESIGN ADVICE, WEB TOOLS, SAFETY INFORMATION, AND OTHER RESOURCES "AS IS" AND WITH ALL FAULTS, AND DISCLAIMS ALL WARRANTIES, EXPRESS AND IMPLIED, INCLUDING WITHOUT LIMITATION ANY IMPLIED WARRANTIES OF MERCHANTABILITY, FITNESS FOR A PARTICULAR PURPOSE OR NON-INFRINGEMENT OF THIRD PARTY INTELLECTUAL PROPERTY RIGHTS.

These resources are intended for skilled developers designing with TI products. You are solely responsible for (1) selecting the appropriate TI products for your application, (2) designing, validating and testing your application, and (3) ensuring your application meets applicable standards, and any other safety, security, regulatory or other requirements.

These resources are subject to change without notice. TI grants you permission to use these resources only for development of an application that uses the TI products described in the resource. Other reproduction and display of these resources is prohibited. No license is granted to any other TI intellectual property right or to any third party intellectual property right. TI disclaims responsibility for, and you will fully indemnify TI and its representatives against, any claims, damages, costs, losses, and liabilities arising out of your use of these resources.

TI's products are provided subject to [TI's Terms of Sale](#) or other applicable terms available either on [ti.com](https://www.ti.com) or provided in conjunction with such TI products. TI's provision of these resources does not expand or otherwise alter TI's applicable warranties or warranty disclaimers for TI products.

TI objects to and rejects any additional or different terms you may have proposed.

Mailing Address: Texas Instruments, Post Office Box 655303, Dallas, Texas 75265
Copyright © 2024, Texas Instruments Incorporated