

## TPS53321 5-A Step-Down Regulator With Integrated Switcher

### 1 Features

- 96% Maximum Efficiency
- Continuous 5-A Output Current
- Supports All MLCC Output Capacitor
- SmoothPWM™ Auto-Skip Eco-Mode™ for Light-Load Efficiency
- Optimized Efficiency at Light and Heavy Loads
- Voltage Mode Control
- Supports Master-Slave Interleaved Operation
- Synchronization up to  $\pm 20\%$  of Nominal Frequency
- Conversion Voltage Range Between 2.9 V and 6 V
- Soft-Stop Output Discharge During Disable
- Adjustable Output Voltage Ranging Between 0.6 V and  $0.84 V \times V_{IN}$
- Overcurrent, Overvoltage, and Overtemperature Protection
- Small 3 mm  $\times$  3 mm, 16-Pin QFN Package
- Open-Drain Power Good Indication
- Internal Boot Strap Switch
- Low  $R_{DS(on)}$ , 24 m $\Omega$  With 3.3-V Input and 19-m $\Omega$  With 5-V Input
- Supports Prebias Start-Up

### 2 Applications

- 5-V Step-Down Rails
- 3.3-V Step-Down Rails

### 3 Description

The TPS53321 device provides a fully integrated 3-V to 5-V  $V_{IN}$  integrated synchronous FET converter solution with 16 total components in 200 mm<sup>2</sup> of PCB area. Due to the low ON-resistance and TI's Proprietary SmoothPWM™ skip mode of operation, it enables 96% peak efficiency and over 90% efficiency at loads as light as 100 mA. It requires only two 22- $\mu$ F ceramic output capacitors for a power dense 5-A solution.

The TPS53321 features a 1.1-MHz switching frequency, skip mode operation support, prebias start-up, internal soft start, output soft discharge, internal VBST switch, power good, EN/input UVLO, overcurrent, overvoltage, undervoltage, and overtemperature protections, and all ceramic output capacitor support. It supports supply voltage from 2.9 V to 3.5 V and conversion voltage from 2.9 V to 6 V. The output voltage is adjustable from 0.6 V to  $0.84 V \times V_{IN}$ .

The TPS53321 is available in the 3 mm  $\times$  3 mm 16-pin QFN package (Green RoHs compliant and Pb free) and operates between  $-40^{\circ}\text{C}$  and  $85^{\circ}\text{C}$ .

#### Device Information<sup>(1)</sup>

PART NUMBER	PACKAGE	BODY SIZE (NOM)
TPS53321	QFN (16)	3.00 mm $\times$ 3.00 mm

(1) For all available packages, see the orderable addendum at the end of the data sheet.

#### Typical Application Circuit

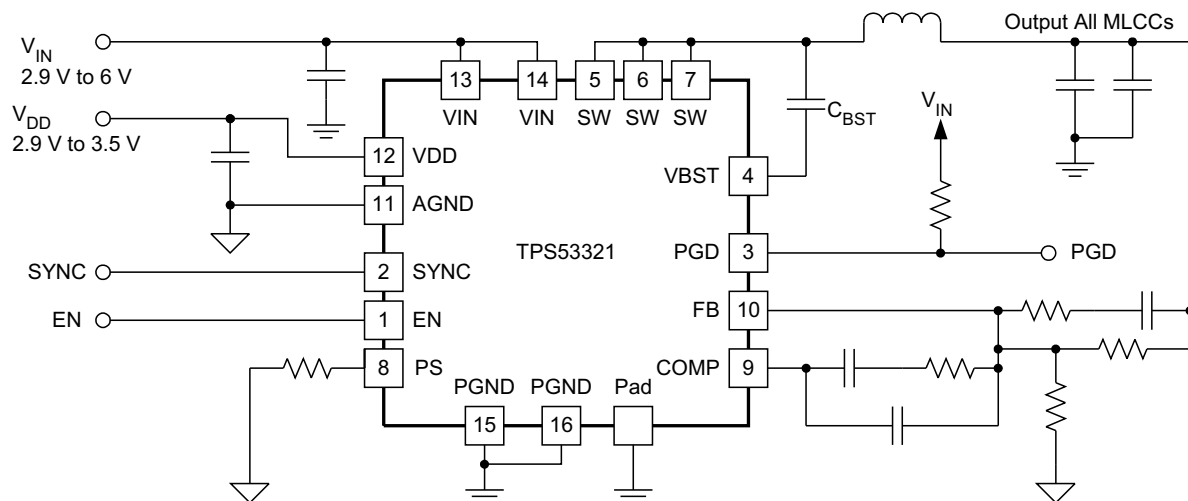

UDG-10204

Copyright © 2016, Texas Instruments Incorporated



## Table of Contents

<b>1 Features</b> .....	<b>1</b>	7.4 Device Functional Modes.....	<b>11</b>
<b>2 Applications</b> .....	<b>1</b>	<b>8 Application and Implementation</b> .....	<b>12</b>
<b>3 Description</b> .....	<b>1</b>	8.1 Application Information.....	<b>12</b>
<b>4 Revision History</b> .....	<b>2</b>	8.2 Typical Application .....	<b>12</b>
<b>5 Pin Configuration and Functions</b> .....	<b>3</b>	<b>9 Power Supply Recommendations</b> .....	<b>18</b>
<b>6 Specifications</b> .....	<b>4</b>	<b>10 Layout</b> .....	<b>19</b>
6.1 Absolute Maximum Ratings .....	4	10.1 Layout Guidelines .....	19
6.2 ESD Ratings.....	4	10.2 Layout Example .....	19
6.3 Recommended Operating Conditions.....	4	<b>11 Device and Documentation Support</b> .....	<b>20</b>
6.4 Thermal Information .....	5	11.1 Receiving Notification of Documentation Updates	20
6.5 Electrical Characteristics.....	5	11.2 Community Resources.....	20
6.6 Typical Characteristics .....	7	11.3 Trademarks .....	20
<b>7 Detailed Description</b> .....	<b>9</b>	11.4 Electrostatic Discharge Caution.....	20
7.1 Overview .....	9	11.5 Glossary .....	20
7.2 Functional Block Diagram .....	9	<b>12 Mechanical, Packaging, and Orderable</b>	
7.3 Feature Description.....	9	<b>Information</b> .....	<b>20</b>

## 4 Revision History

NOTE: Page numbers for previous revisions may differ from page numbers in the current version.

### Changes from Original (December 2010) to Revision A

Page

• Added <i>ESD Ratings</i> table, <i>Feature Description</i> section, <i>Device Functional Modes</i> , <i>Application and Implementation</i> section, <i>Power Supply Recommendations</i> section, <i>Layout</i> section, <i>Device and Documentation Support</i> section, and <i>Mechanical, Packaging, and Orderable Information</i> section .....	<b>1</b>
• Deleted <i>Ordering Information</i> table; see POA at the end of the data sheet.....	<b>1</b>
• Deleted Lead temperature, 1.6 mm (1/16 inch) from case for 10 seconds: 300°C.....	<b>4</b>
• Deleted <i>Package Dissipation Ratings</i> table.....	<b>5</b>
• Added <i>Thermal Information</i> table .....	<b>5</b>
• Changed R2 value in <i>Typical 3.3-V Input Application Circuit Diagram</i> From: 4.02 kΩ To: 2.67 kΩ .....	<b>12</b>
• Changed R2 value in <i>Master and Slave Configuration Schematic</i> From: 4.02 kΩ To: 2.67 kΩ .....	<b>16</b>
• Changed R12 value in <i>Master and Slave Configuration Schematic</i> From: 2.67 kΩ To: 4.02 kΩ .....	<b>16</b>

## 5 Pin Configuration and Functions

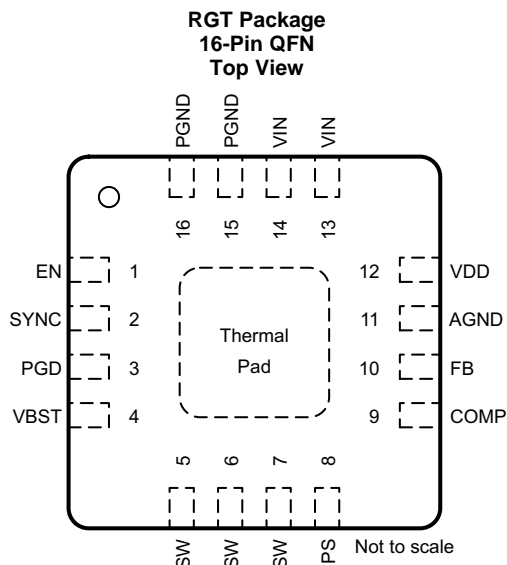

### Pin Functions

PIN		TYPE <sup>(1)</sup>	DESCRIPTION
NO.	NAME		
1	EN	I	Enable. Internally pulled up to VDD with a 1.35-M $\Omega$ resistor.
2	SYNC	B	Synchronization signal for input interleaving. Master SYNC pin sends out 180° out-of-phase signal to slave SYNC. SYNC frequency must be within $\pm 20\%$ of slave nominal frequency.
3	PGD	O	Power good output flag. Open-drain output. Pull up to an external rail through a resistor.
4	VBST	P	Supply input for high-side MOSFET (bootstrap terminal). Connect capacitor from this pin to SW terminal.
5	SW	B	Output inductor connection to integrated power devices
6	SW	B	Output inductor connection to integrated power devices
7	SW	B	Output inductor connection to integrated power devices
8	PS	I	Mode configuration pin (with 10- $\mu$ A current): Connecting to ground: FCCM slave Pulled high or floating (internal pulled high): FCCM master Connect a 24.3-k $\Omega$ resistor to GND: DE slave Connect a 57.6-k $\Omega$ resistor to GND: HEF mode Connect a 105-k $\Omega$ resistor to GND : reserved mode Connect a 174-k $\Omega$ resistor to GND: DE master
9	COMP	O	Error amplifier compensation terminal. Type III compensation method is recommended for stability.
10	FB	I	Voltage feedback. Also used for OVP, UVP, and PGD determination.
11	AGND	G	Device analog ground terminal
12	VDD	P	Input bias supply for analog functions
13	VIN	P	Gate driver supply and power conversion voltage input
14	VIN	P	Gate driver supply and power conversion voltage input
15	PGND	P	IC power GND terminal
16	PGND	P	IC power GND terminal

(1) B = Bidirectional, G = Ground, I = Input, O = Output, P = Supply

## 6 Specifications

### 6.1 Absolute Maximum Ratings

over operating free-air temperature range (unless otherwise noted)<sup>(1)</sup>

		MIN	MAX	UNIT	
Input voltage	VIN, EN	-0.3	7	V	
	VBST	-0.3	17		
	VBST(with respect to SW)	-0.3	7		
	FB, PS, VDD	-0.3	3.7		
Output voltage	SW	DC	-0.3	7	V
		Pulse < 20 ns, E = 5 μJ	-3	10	
	PGD	-0.3	7		
	COMP, SYNC	-0.3	3.7		
	PGND	-0.3	0.3		
Junction temperature, T <sub>J</sub>		-40	150	°C	
Ambient temperature, T <sub>A</sub>		-40	85	°C	
Storage temperature, T <sub>stg</sub>		-55	150	°C	

(1) Stresses beyond those listed under *Absolute Maximum Ratings* may cause permanent damage to the device. These are stress ratings only, which do not imply functional operation of the device at these or any other conditions beyond those indicated under *Recommended Operating Conditions*. Exposure to absolute-maximum-rated conditions for extended periods may affect device reliability.

### 6.2 ESD Ratings

		VALUE	UNIT
V <sub>(ESD)</sub> Electrostatic discharge	Human-body model (HBM), per ANSI/ESDA/JEDEC JS-001 <sup>(1)</sup>	±2000	V
	Charged-device model (CDM), per JEDEC specification JESD22-C101 <sup>(2)</sup>	±500	

(1) JEDEC document JEP155 states that 500-V HBM allows safe manufacturing with a standard ESD control process.

(2) JEDEC document JEP157 states that 250-V CDM allows safe manufacturing with a standard ESD control process.

### 6.3 Recommended Operating Conditions

		MIN	NOM	MAX	UNIT
Input voltage	VIN	2.9		6	V
	VDD	2.9	3.3	3.5	
	VBST	-0.1		13.5	
	VBST(with respect to SW)	-0.1		6	
	EN	-0.1		6	
	FB, PS	-0.1		3.5	
Output voltage	SW	-1		6.5	V
	PGD	-0.1		6	
	COMP, SYNC	-0.1		3.5	
	PGND	-0.1		0.1	
T <sub>J</sub>	Junction temperature	-40		125	°C

## 6.4 Thermal Information

THERMAL METRIC <sup>(1)</sup>		TPS53321	UNIT
		RGT (QFN)	
		16 PINS	
R <sub>θJA</sub>	Junction-to-ambient thermal resistance	42.8	°C/W
R <sub>θJC(top)</sub>	Junction-to-case (top) thermal resistance	51.3	°C/W
R <sub>θJB</sub>	Junction-to-board thermal resistance	16	°C/W
ψ <sub>JT</sub>	Junction-to-top characterization parameter	0.7	°C/W
ψ <sub>JB</sub>	Junction-to-board characterization parameter	16	°C/W
R <sub>θJC(bot)</sub>	Junction-to-case (bottom) thermal resistance	4.4	°C/W

(1) For more information about traditional and new thermal metrics, see the [Semiconductor and IC Package Thermal Metrics](#) application report.

## 6.5 Electrical Characteristics

over recommended free-air temperature range, V<sub>IN</sub> = 3.3 V, V<sub>VDD</sub> = 3.3 V, and PGND = GND (unless otherwise noted)

PARAMETER		TEST CONDITIONS	MIN	TYP	MAX	UNIT
<b>SUPPLY: VOLTAGE, CURRENTS, and UVLO</b>						
V <sub>IN</sub>	VIN supply voltage	Nominal input voltage range	2.9		6	V
I <sub>VINSDN</sub>	VIN shutdown current	EN = LO			3	μA
V <sub>UVLO</sub>	VIN UVLO threshold	Ramp up, EN = HI		2.8		V
V <sub>UVLOHYS</sub>	VIN UVLO hysteresis	VIN UVLO Hysteresis		130		mV
V <sub>DD</sub>	Internal circuitry supply voltage	Nominal 3.3-V input voltage range	2.9	3.3	3.5	V
I <sub>DDSDN</sub>	VDD shutdown current	EN = LO			5	μA
I <sub>DD</sub>	Standby current	EN = HI, no switching		2.2	3.5	mA
V <sub>DDUVLO</sub>	3.3-V UVLO threshold	Ramp up, EN = HI		2.8		V
V <sub>DDUVLOHYS</sub>	3.3-V UVLO hysteresis			75		mV
<b>VOLTAGE FEEDBACK LOOP: VREF AND ERROR AMPLIFIER</b>						
V <sub>VREF</sub>	VREF	Internal precision reference voltage		0.6		V
TOL <sub>VREF</sub>	VREF Tolerance	0°C ≤ T <sub>A</sub> ≤ 85°C	-1%		1%	
		-40°C ≤ T <sub>A</sub> ≤ 85°C	-1.25%		1.25%	
UGBW <sup>(1)</sup>	Unity gain bandwidth		14			MHz
A <sub>OL</sub> <sup>(1)</sup>	Open-loop gain		80			dB
I <sub>FBINT</sub>	FB input leakage current	Sourced from FB pin			30	nA
I <sub>EAMAX</sub> <sup>(1)</sup>	Output sinking and sourcing current	C <sub>COMP</sub> = 20 pF		5		mA
SR <sup>(1)</sup>	Slew rate			5		V/μs
<b>OCP: OVERCURRENT AND ZERO CROSSING</b>						
I <sub>OCP</sub>	Overcurrent limit on upper FET	When I <sub>OUT</sub> exceeds this threshold for 4 consecutive cycles. V <sub>IN</sub> =3.3 V, V <sub>OUT</sub> =1.5 V with 1-μH inductor, T <sub>A</sub> = 25°C	6	6.5	7	A
I <sub>OCPH</sub>	One time overcurrent latch off on the lower FET	Immediately shuts down when sensed current reach this value. V <sub>IN</sub> =3.3 V, V <sub>OUT</sub> =1.5 V with 1-μH inductor, T <sub>A</sub> = 25°C	6.25	6.8	7.35	A
t <sub>HICCUP</sub>	Hiccup time interval		12.5	14.5	16.5	ms
V <sub>ZXOFF</sub> <sup>(1)</sup>	Zero crossing comparator internal offset	PGND – SW, skip mode	-4.5	-3	-1.5	mV
<b>PROTECTION: OVP, UVP, PGD, AND INTERNAL THERMAL SHUTDOWN</b>						
V <sub>OVP</sub>	Overvoltage protection threshold voltage	Measured at FB w/r/t VREF	114%	117%	120%	
V <sub>UVP</sub>	Undervoltage protection threshold voltage	Measured at FB w/r/t VREF	80%	83%	86%	

(1) Ensured by design. Not production tested.

**Electrical Characteristics (continued)**

 over recommended free-air temperature range,  $V_{IN} = 3.3\text{ V}$ ,  $V_{VDD} = 3.3\text{ V}$ , and  $PGND = GND$  (unless otherwise noted)

PARAMETER		TEST CONDITIONS	MIN	TYP	MAX	UNIT
$V_{PGDL}$	PGD low threshold	Measured at FB w/r/t VREF	80%	83%	86%	
$V_{PGDU}$	PGD upper threshold	Measured at FB w/r/t VREF	114%	117%	120%	
$V_{INMINPG}$	Minimum $V_{in}$ voltage for valid PGD at start-up	Measured at $V_{IN}$ with 1-mA (or 2-mA) sink current on PGD pin at start-up		1		V
THSD <sup>(1)</sup>	Thermal shutdown	Latch off controller, attempt soft-stop	130	140	150	°C
THSD <sub>HYS</sub> <sup>(1)</sup>	Thermal shutdown hysteresis	Controller restarts after temperature has dropped		40		°C
<b>LOGIC PINS: I/O VOLTAGE AND CURRENT</b>						
$V_{PGPD}$	PGD pulldown voltage	Pulldown voltage with 4-mA sink current		0.2	0.4	V
$I_{PGLK}$	PGD leakage current	Hi-Z leakage current, apply 3.3-V in off state	-2	0	2	μA
$R_{ENPU}$	Enable pullup resistor			1.35		MΩ
$V_{ENH}$	EN logic high threshold		1.1	1.18	1.3	V
$V_{ENHYS}$	EN hysteresis			0.18	0.24	V
$PS_{THS}$	PS mode threshold voltage	Level 1 to level 2 <sup>(2)</sup>		0.12		V
		Level 2 to level 3		0.4		
		Level 3 to level 4		0.8		
		Level 4 to level 5		1.4		
		Level 5 to level 6		2.2		
$I_{PS}$	PS source	10-μA pullup current when enabled	8	10	12	μA
$f_{SYNCSL}$	Slave SYNC frequency range	Versus nominal switching frequency	-20%		20%	
$PW_{SYNC}$	SYNC low pulse width			110		ns
$I_{SYNC}$	SYNC pin sink current	$T_A = 25^\circ\text{C}$		10		μA
$V_{SYNCTHS}$ <sup>(1)</sup>	SYNC threshold	Falling edge		1		V
$V_{SYNCHYS}$ <sup>(1)</sup>	SYNC hysteresis			0.5		V
<b>BOOT STRAP: VOLTAGE AND LEAKAGE CURRENT</b>						
$I_{VBSTLK}$	VBST leakage current	$V_{IN} = 3.3\text{ V}$ , $V_{VBST} = 6.6\text{ V}$ , $T_A = 25^\circ\text{C}$			1	μA
<b>TIMERS: SS, FREQUENCY, RAMP, ON-TIME AND I/O TIMING</b>						
$t_{SS\_1}$	Delay after EN asserting	EN = HI, master or HEF mode		0.2		ms
$t_{SS\_2}$	Delay after EN asserting	EN = HI, slave waiting time		0.5		ms
$t_{SS\_3}$	Soft-start ramp-up time	Rising from $V_{SS} = 0\text{ V}$ to $V_{SS} = 0.6\text{ V}$		0.4		ms
$t_{PGDENDLY}$	PGD start-up delay time	Rising from $V_{SS} = 0\text{ V}$ to $V_{SS} = 0.6\text{ V}$ , from $V_{SS}$ reaching 0.6 V to $V_{PGD}$ going high		1.2		ms
$t_{OVDPDY}$	Overvoltage protection delay time	Time from FB out of +20% of VREF to OVP fault	1	1.7	2.5	μs
$t_{UVDPDY}$	Undervoltage protection delay time	Time from FB out of -20% of VREF to UVP fault		11		μs
$f_{SW}$	Switching frequency control	FCCM	0.99	1.1	1.21	MHz
	Ramp amplitude <sup>(1)</sup>	$2.9\text{ V} < V_{IN} < 6.0\text{ V}$		$V_{IN}/4$		V
$t_{MIN(off)}$	Minimum OFF time	FCCM or DE mode		100	140	ns
		HEF mode		175	250	
$D_{MAX}$	Maximum duty cycle, FCCM and DE mode	$f_{SW} = 1.1\text{ MHz}$ , $0^\circ\text{C} \leq T_A \leq 85^\circ\text{C}$	84%	89%		
	Maximum duty cycle, HEF mode	$f_{SW} = 1.1\text{ MHz}$ , $0^\circ\text{C} \leq T_A \leq 85^\circ\text{C}$	75%	81%		
$R_{SFTSTP}$	Soft-discharge transistor resistance	$V_{EN} = \text{Low}$ , $V_{IN} = 3.3\text{ V}$ , $V_{OUT} = 0.5\text{ V}$		60		Ω

(2) See PS pin description for levels.

### 6.6 Typical Characteristics

Inductor PCMC065T-1R0 (1  $\mu$ H, 5.6 m $\Omega$ ) is used.

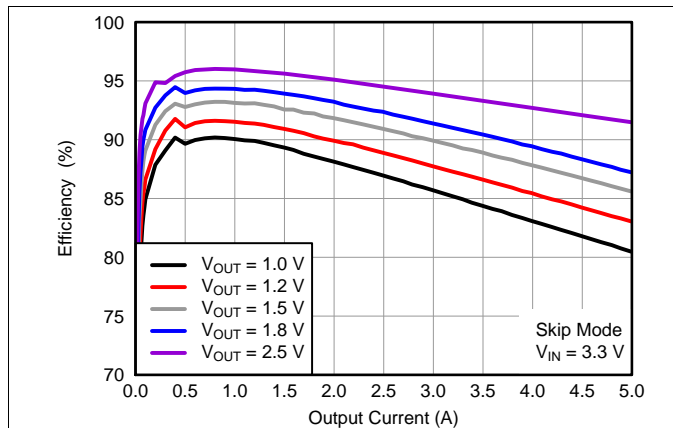

Figure 1. Efficiency vs Output Current, Skip Mode,  $V_{IN} = 3.3$  V

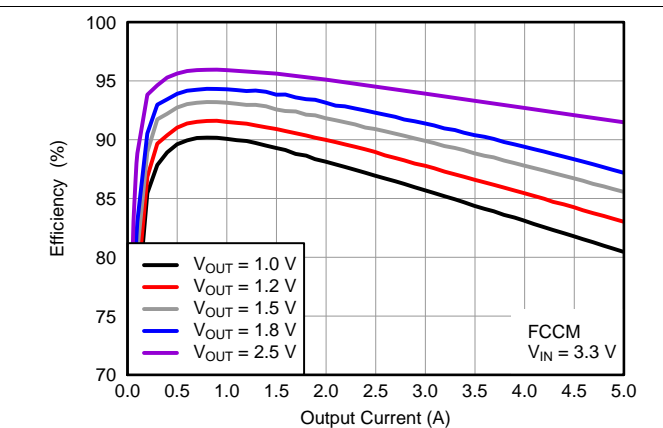

Figure 2. Efficiency vs Output Current, FCCM,  $V_{IN} = 3.3$  V

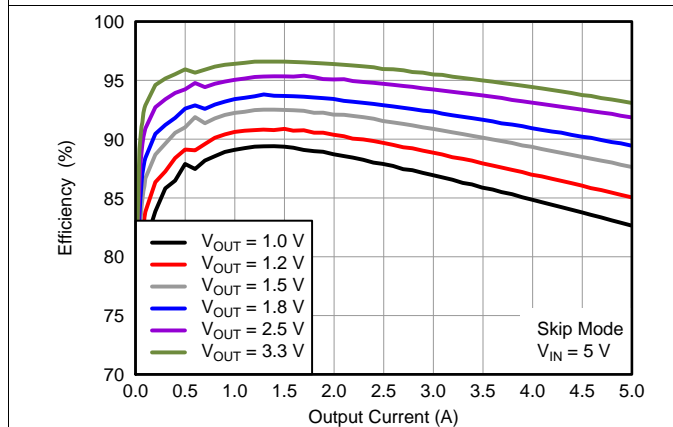

Figure 3. Efficiency vs Output Current, Skip Mode,  $V_{IN} = 5$  V

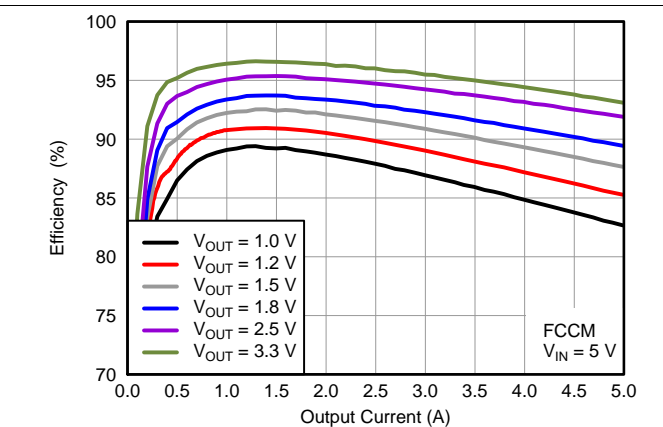

Figure 4. Efficiency vs Output Current, FCCM,  $V_{IN} = 5$  V

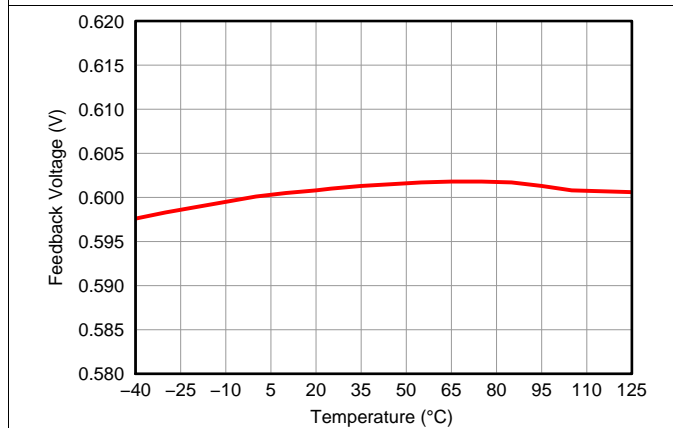

Figure 5. Feedback Voltage vs Ambient Temperature

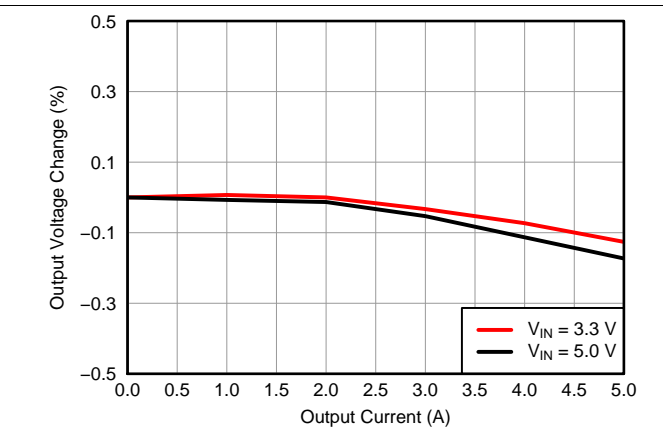

Figure 6. Output Voltage Change vs Output Current

Typical Characteristics (continued)

Inductor PCMC065T-1R0 (1  $\mu$ H, 5.6 m $\Omega$ ) is used.

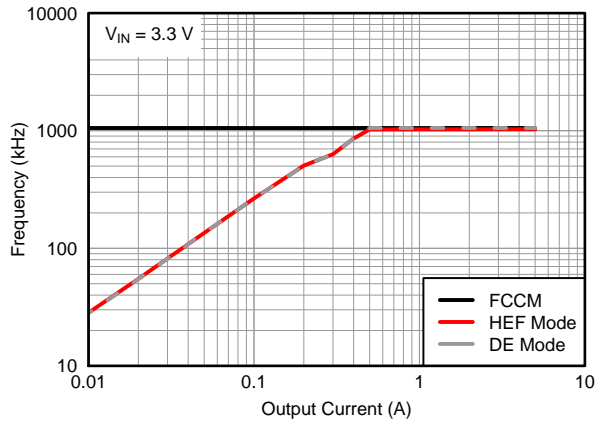

Figure 7. Frequency vs Output Current at  $V_{IN} = 3.3$  V

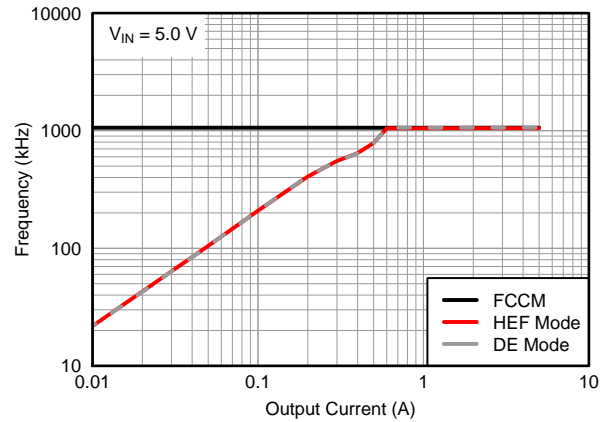

Figure 8. Frequency vs Output Current at  $V_{IN} = 5.0$  V

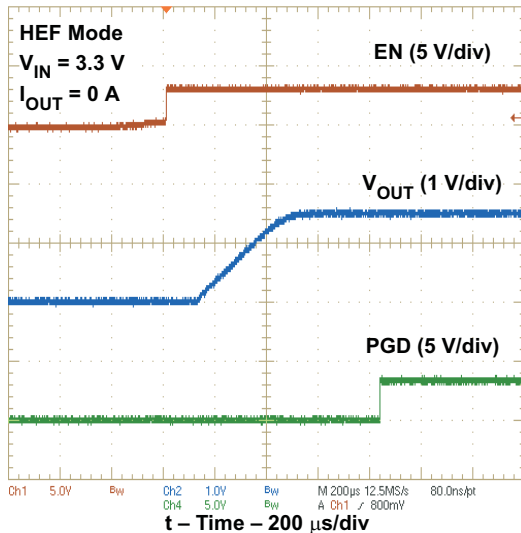

Figure 9. Normal Start-Up Waveform

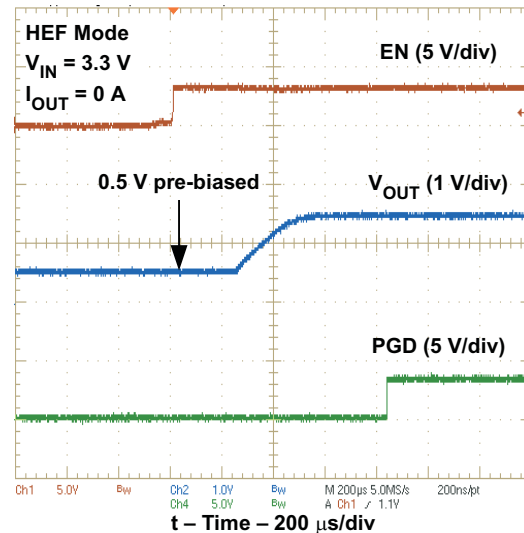

Figure 10. Prebias Start-Up Waveform

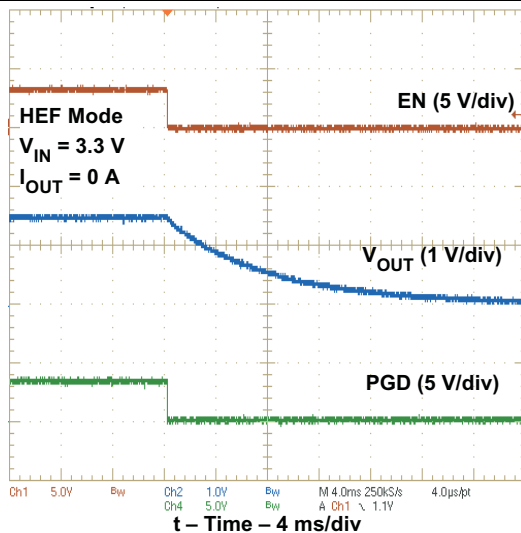

Figure 11. Soft-Stop Waveform

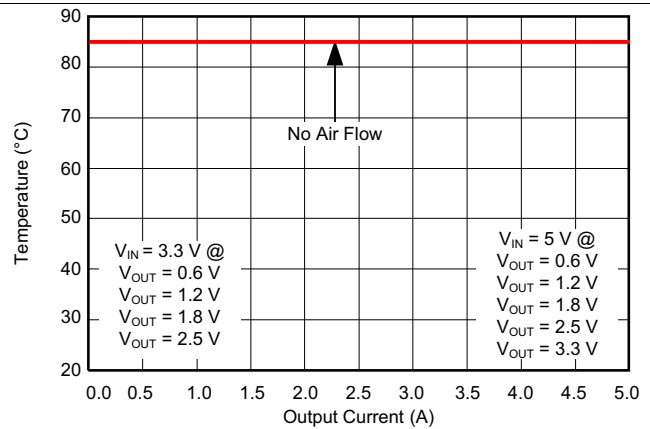

Figure 12. Safe Operating Area



## 7 Detailed Description

### 7.1 Overview

The TPS53321 is a high-efficiency switching regulator with two integrated N-channel MOSFETs and is capable of delivering up to 5 A of load current. The TPS53321 provides output voltage between 0.6 V and  $0.84 \times V_{IN}$  from 2.9 V to 6 V wide input voltage range.

This device employs five operation modes to fit various application requirements. The *master or slave* mode enables a two-phase interleaved operation to reduce input ripple. The *skip* mode operation provides reduced power loss and increases the efficiency at light load. The unique, patented PWM modulator enables smooth light load to heavy load transition while maintaining fast load transient.

### 7.2 Functional Block Diagram

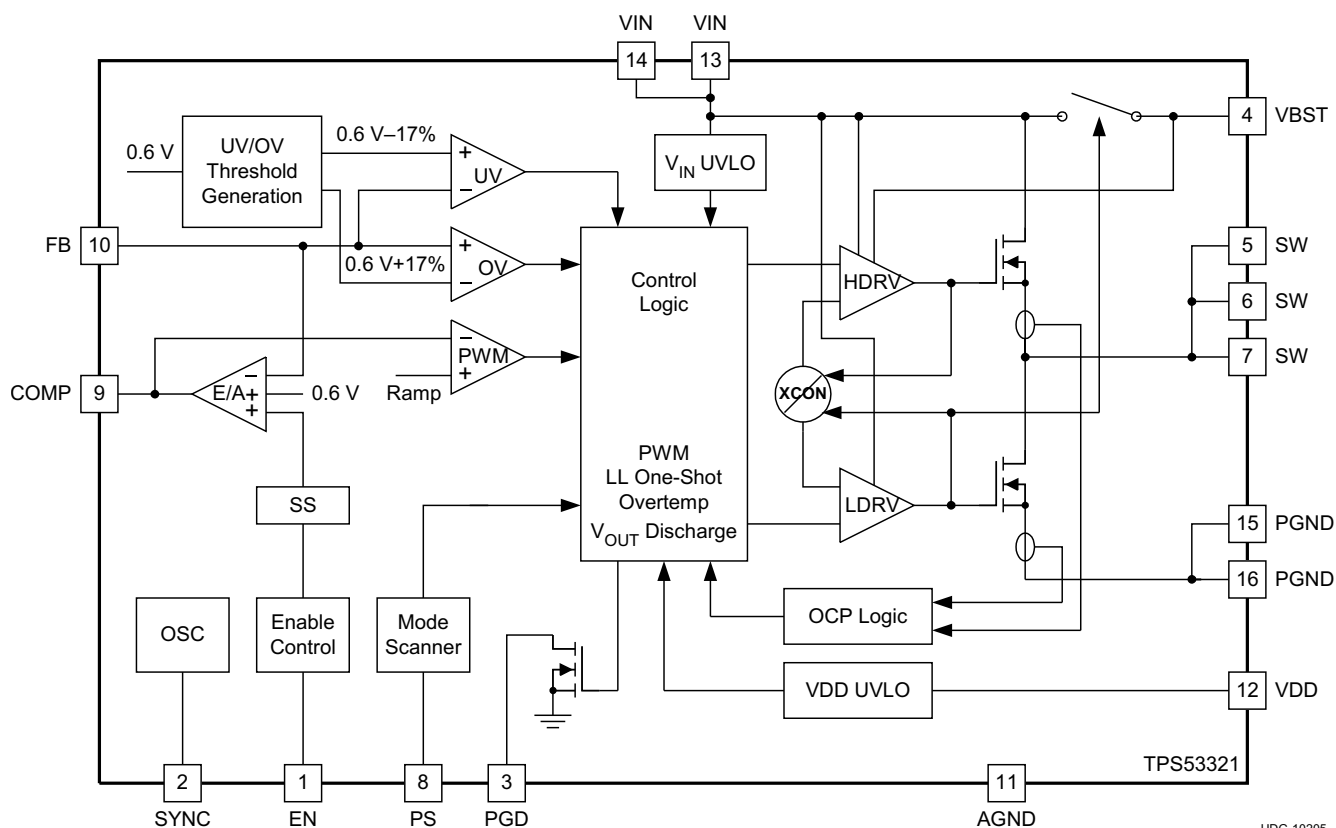

UDG-10205

Copyright © 2016, Texas Instruments Incorporated

### 7.3 Feature Description

#### 7.3.1 Soft Start

The soft-start function reduces the inrush current during the start up sequence. A slow-rising reference voltage is generated by the soft-start circuitry and sent to the input of the error amplifier. When the soft-start ramp voltage is less than 600 mV, the error amplifier uses this ramp voltage as the reference. When the ramp voltage reaches 600 mV, the error amplifier switches to a fixed 600-mV reference. The typical soft-start time is 400  $\mu$ s.

#### 7.3.2 Power Good

The TPS53321 monitors the voltage on the FB pin. If the FB voltage is between 83% and 117% of the reference voltage, the power good signal remains high. If the FB voltage falls outside of these limits, the internal open-drain output pulls the power good pin (PGD) low.

## Feature Description (continued)

During start-up,  $V_{IN}$  must be higher than 1 V to have valid power good logic, and the power good signal is delayed for 1.2 ms after the FB voltage falls to within the power good limits. There is also 10- $\mu$ s delay during the shutdown sequence.

### 7.3.3 Undervoltage Lockout (UVLO) Protection

The TPS53321 provides undervoltage lockout (UVLO) protection for both power input ( $V_{IN}$ ) and bias input (VDD) voltage. If either of them is lower than the UVLO threshold voltage minus the hysteresis, the device shuts off. When the voltage rises above the threshold voltage, the device restarts. The typical UVLO rising threshold is 2.8 V for both  $V_{IN}$  and  $V_{VDD}$ . A hysteresis voltage of 130 mV for  $V_{IN}$  and 75 mV for  $V_{VDD}$  is also provided to prevent glitch.

### 7.3.4 Overcurrent Protection

The TPS53321 continuously monitors the current flowing through the high-side and the low-side MOSFETs. If the current through the high-side FET exceeds 6.5 A, the high-side FET turns off and the low-side FET turns on until the next PWM cycle. An overcurrent (OC) counter starts to increment each occurrence of an overcurrent event. The converter shuts down immediately when the OC counter reaches four. The OC counter resets if the detected current is less 6.5 A after an OC event.

Another set of overcurrent circuitry monitors the current flowing through low-side FET. If the current through the low-side FET exceeds 6.8 A, the overcurrent protection is enabled and immediately turns off both the high-side and the low-side FETs and shuts down the converter. The device is fully protected against overcurrent during both on-time and off-time. The device attempts to restart after a hiccup delay of 14.5 ms (typical). If the overcurrent condition clears before restart, the device starts up normally.

### 7.3.5 Overvoltage Protection

The TPS53321 monitors the voltage divided feedback voltage to detect overvoltage and undervoltage conditions. When the feedback voltage is greater than 117% of the reference, the high-side MOSFET turns off and the low-side MOSFET turns on. The output voltage then drops until it reaches the undervoltage threshold. At that point the low-side MOSFET turns off and the device enters a high-impedance state.

### 7.3.6 Undervoltage Protection

When the feedback voltage is lower than 83% of the reference voltage, the undervoltage protection timer starts. If the feedback voltage remains lower than the undervoltage threshold voltage after 10  $\mu$ s, the device turns off both the high-side and the low-side MOSFETs and goes into a high-impedance state. The device attempts to restart after a hiccup delay of 14.5 ms (typical).

### 7.3.7 Overtemperature Protection

The TPS53321 continuously monitors the die temperature. If the die temperature exceeds the threshold value (140°C typical), the device shuts off. When the device temperature falls to 40°C below the overtemperature threshold, it restarts and returns to normal operation.

### 7.3.8 Output Discharge

When the enable pin is low, the TPS53321 discharges the output capacitors through an internal MOSFET switch between SW and PGND while high-side and low-side MOSFETs remain off. The typical discharge switch ON-resistance is 60  $\Omega$ . This function is disabled when  $V_{IN}$  is less than 1 V.

### 7.3.9 Master and Slave Operation and Synchronization

Two TPS53321 can operate interleaved when configured as master and slave. The SYNC pins of the two devices are connected together for synchronization. In CCM, the master device sends the 180° out-of-phase pulse to the slave device through the SYNC pin, which determines the leading edge of the PWM pulse. If the slave device does not receive the SYNC pulse from the master device or if the SYNC connection is broken during operation, the slave device continues to operate using its own internal clock.

## Feature Description (continued)

In DE mode, the master and slave switching node does not synchronize to each other if either one of them is operating in DCM. When both master and slave enter CCM, the switching nodes of the master and the slave synchronize to each other.

The SYNC pin of the slave device can also connect to external clock source within  $\pm 20\%$  of the 1.1-MHz switching frequency. The falling edge of the SYNC triggers the rising edge of the PWM signal.

## 7.4 Device Functional Modes

### 7.4.1 Operation Modes

The TPS53321 offers five operation modes determined by the PS pin connections listed in [Table 1](#).

**Table 1. Operation Mode Selection**

PS PIN CONNECTION	OPERATION MODE	AUTO-SKIP AT LIGHT LOAD	MASTER/SLAVE SUPPORT
GND	FCCM Slave	—	Slave
24.3 k $\Omega$ to GND	DE Slave	Yes	Slave
57.6 k $\Omega$ to GND	HEF Mode	Yes	—
174 k $\Omega$ to GND	DE Master	Yes	Master
Floating or pulled to VDD	FCCM Master	—	Master

In *forced continuous conduction* mode (FCCM), the high-side FET is ON during the on-time and the low-side FET is ON during the off-time. The switching is synchronized to the internal clock thus the switching frequency is fixed.

In *diode emulation* (DE) mode, the high-side FET is ON during the on-time and low-side FET is ON during the off-time until the inductor current reaches zero. An internal zero-crossing comparator detects the zero crossing of inductor current from positive to negative. When the inductor current reaches zero, the comparator sends a signal to the logic control and turns off the low-side FET.

When the load is increased, the inductor current is always positive and the zero-crossing comparator does not send a zero-crossing signal. The converter enters into *continuous conduction* mode (CCM) when no zero-crossing is detected for two consecutive PWM pulses. The switching synchronizes to the internal clock and the switching frequency is fixed.

In *high-efficiency* (HEF) mode, the operation is the same as DE mode at light load. However, the converter does not synchronize to the internal clock during CCM. Instead, the PWM modulator determines the switching frequency.

### 7.4.2 Eco-Mode™ Light-Load Operation

In skip modes (DE and HEF) when the load current is less than one-half of the inductor peak current, the inductor current becomes negative by the end of off-time. During light load operation, the low-side MOSFET is turned off when the inductor current reaches zero. The energy delivered to the load per switching cycle is increased compared to the normal PWM mode operation and the switching frequency is reduced. The switching loss is reduced, thereby improving efficiency.

In both DE and HEF mode, the switching frequency is reduced in discontinuous conduction mode (DCM). When the load current is 0 A, the minimum switching frequency is reached. The difference between  $V_{V_{BST}}$  and  $V_{SW}$  must be maintained at a value higher than 2.4 V.

### 7.4.3 Forced Continuous Conduction Mode (FCCM)

When the PS pin is grounded or greater than 2.2 V, the TPS53321 is operating in *forced continuous conduction mode* in both light-load and heavy-load conditions. In this mode, the switching frequency remains constant over the entire load range, making it suitable for applications that require tight control of switching frequency at a cost of lower efficiency at light load.

## 8 Application and Implementation

### NOTE

Information in the following applications sections is not part of the TI component specification, and TI does not warrant its accuracy or completeness. TI's customers are responsible for determining suitability of components for their purposes. Customers should validate and test their design implementation to confirm system functionality.

### 8.1 Application Information

The TPS53321 device is a high-efficiency synchronous-buck converter. The device suits low output voltage point-of-load applications with 5-A or lower output current in computing and similar digital consumer applications.

### 8.2 Typical Application

This design example describes a voltage-mode, 5-A synchronous buck converter with integrated MOSFETs. The device provides a fixed 1.5-V output at up to 5 A from a 3.3-V input bus.

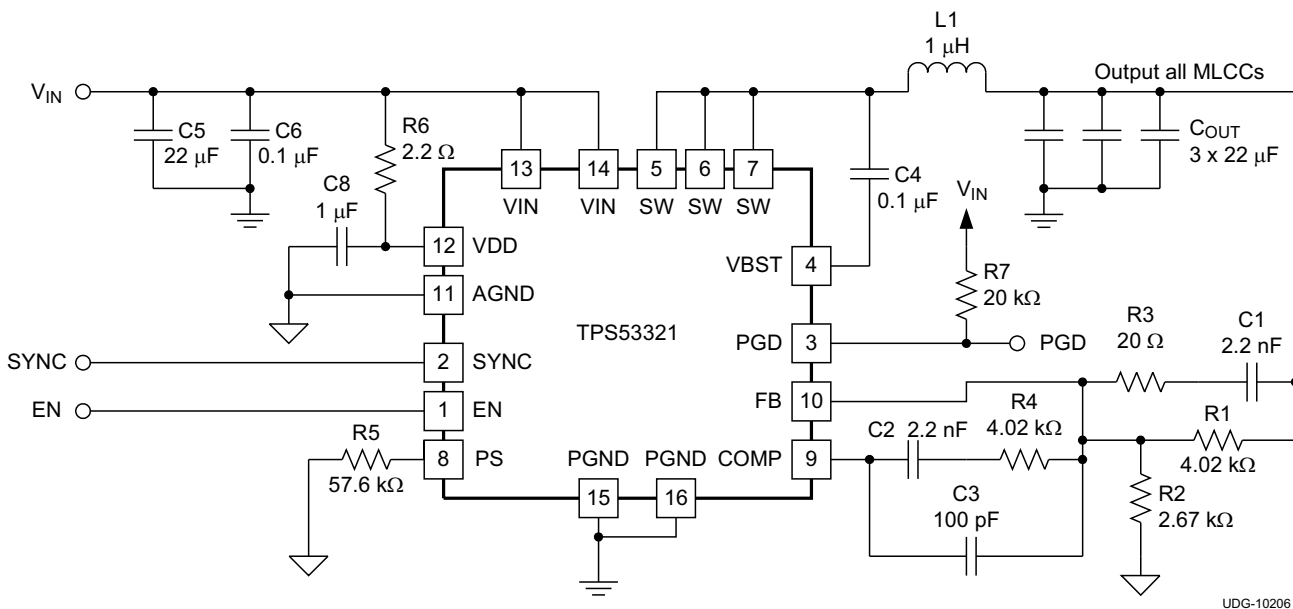

Copyright © 2016, Texas Instruments Incorporated

Figure 13. Typical 3.3-V Input Application Circuit Diagram

#### 8.2.1 Design Requirements

Table 2 lists the design specifications for this application example.

Table 2. TPS53321 Design Example Specifications

PARAMETER	TEST CONDITIONS	MIN	TYP	MAX	UNIT
<b>INPUT CHARACTERISTICS</b>					
Input voltage, $V_{IN}$	$V_{in}$	2.9	3.3	6	V
Maximum input current	$V_{in} = 3.3\text{ V}, 1.5\text{ V}/5\text{ A}$		2.67		A
No load input current	$V_{in} = 3.3\text{ V}, 1.5\text{ V}/0\text{ A}$		12.5		mA

## Typical Application (continued)

**Table 2. TPS53321 Design Example Specifications (continued)**

PARAMETER	TEST CONDITIONS	MIN	TYP	MAX	UNIT
<b>OUTPUT CHARACTERISTICS</b>					
Output voltage, $V_o$		1.485	1.5	1.515	V
Output voltage regulation	Line regulation		0.1%		
	Load regulation		1%		
Output voltage ripple	$V_{in} = 3.3\text{ V}, 1.5\text{ V}/0\text{ A to } 5\text{ A}$			20	mVpp
Output load current		0		5	A
Output over current			6.5		A
<b>OUTPUT CHARACTERISTICS</b>					
Switching frequency	Fixed		1.1		MHz
1.5-V full load efficiency	$V_{in} = 3.3\text{ V}, 1.5\text{ V}/5\text{ A}$		85.94%		
	$V_{in} = 5\text{ V}, 1.5\text{ V}/5\text{ A}$		87%		
Operating temperature			25		°C

### 8.2.2 Detailed Design Procedure

#### 8.2.2.1 Determine the Value of R1 and R2

The output voltage is programmed by the voltage-divider resistor, R1 and R2 shown in [Figure 13](#). R1 is connected between the FB pin and the output, and R2 is connected between the FB pin and GND. The recommended value for R1 is from 1 kΩ to 5 kΩ. Determine R2 using equation in [Equation 1](#).

$$R2 = \frac{0.6}{V_{OUT} - 0.6} \times R1 \quad (1)$$

#### 8.2.2.2 Choose the Inductor

The inductance value must be determined to give the ripple current of approximately 20% to 40% of maximum output current. The inductor ripple current is determined by [Equation 2](#).

$$I_{L(\text{ripple})} = \frac{1}{L \times f_{SW}} \times \frac{(V_{IN} - V_{OUT}) \times V_{OUT}}{V_{IN}} \quad (2)$$

The inductor also requires low DCR to achieve good efficiency, as well as enough room above peak inductor current before saturation.

#### 8.2.2.3 Choose the Output Capacitor(s)

The output capacitor selection is determined by output ripple and transient requirement. When operating in CC mode, the output ripple has three components calculated with [Equation 3](#) through [Equation 6](#).

$$V_{RIPPLE} = V_{RIPPLE(C)} + V_{RIPPLE(ESR)} + V_{RIPPLE(ESL)} \quad (3)$$

$$V_{RIPPLE(C)} = \frac{I_{L(\text{ripple})}}{8 \times C_{OUT} \times f_{SW}} \quad (4)$$

$$V_{RIPPLE(ESR)} = I_{L(\text{ripple})} \times ESR \quad (5)$$

$$V_{RIPPLE(ESL)} = \frac{V_{IN} \times ESL}{L} \quad (6)$$

When ceramic output capacitors are used, the ESL component is usually negligible. In the case when multiple output capacitors are used, ESR and ESL must be the equivalent of ESR and ESL of all the output capacitor in parallel.

When operating in DCM, the output ripple is dominated by the component determined by capacitance. It also varies with load current and can be expressed as shown in [Equation 7](#).

$$V_{\text{RIPPLE(DCM)}} = \frac{(\alpha \times I_{L(\text{ripple})} - I_{\text{OUT}})^2}{2 \times C_{\text{OUT}} \times f_{\text{SW}} \times I_{L(\text{ripple})}}$$

where

- $\alpha$  is the DCM on-time coefficient and can be expressed in [Equation 8](#) (typical value 1.25) (7)

$$\alpha = \frac{t_{\text{ON(DCM)}}}{t_{\text{ON(CCM)}}} \tag{8}$$

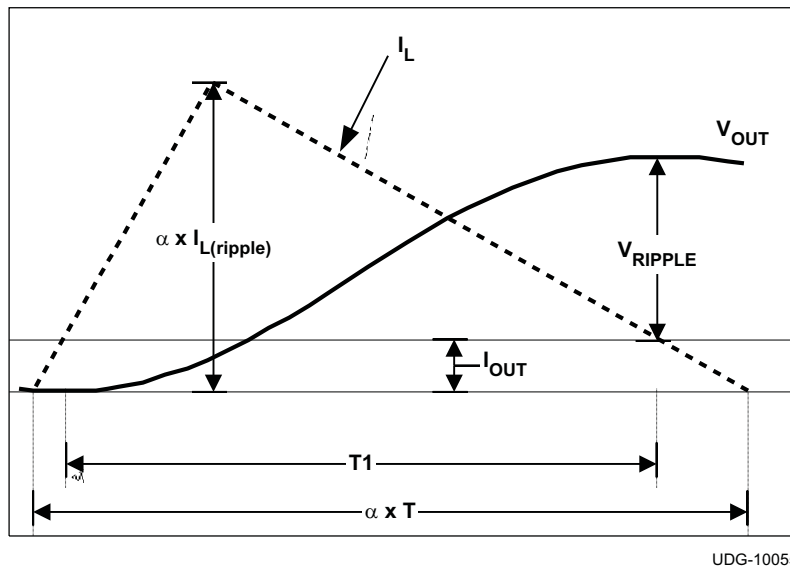

**Figure 14. DCM  $V_{\text{OUT}}$  Ripple Calculation**

### 8.2.2.4 Choose the Input Capacitor

The selection of input capacitor must be determined by the ripple current requirement. The ripple current generated by the converter must be absorbed by the input capacitors as well as the input source. The RMS ripple current from the converter can be expressed in [Equation 9](#).

$$I_{\text{IN(ripple)}} = I_{\text{OUT}} \times \sqrt{D \times (1-D)}$$

where

- $D$  is the duty cycle and can be expressed as shown in [Equation 10](#) (9)

$$D = \frac{V_{\text{OUT}}}{V_{\text{IN}}} \tag{10}$$

To minimize the ripple current drawn from the input source, sufficient input decoupling capacitors must be placed close to the device. The ceramic capacitor is recommended because it provides low ESR and low ESL. The input voltage ripple can be calculated as shown in [Equation 11](#) when the total input capacitance is determined.

$$V_{\text{IN(ripple)}} = \frac{I_{\text{OUT}} \times D}{f_{\text{SW}} \times C_{\text{IN}}} \tag{11}$$

### 8.2.2.5 Compensation Design

The TPS53321 uses voltage mode control. To effectively compensate the power stage and ensure fast transient response, Type III compensation is typically used.

The control to output transfer function can be described in [Equation 12](#).

$$G_{CO} = 4 \times \frac{1 + s \times C_{OUT} \times ESR}{1 + s \times \left( \frac{L}{DCR + R_{LOAD}} + C_{OUT} \times (ESR + DCR) \right) + s^2 \times L \times C_{OUT}} \quad (12)$$

The output L-C filter introduces a double pole which can be calculated as shown in Equation 13.

$$f_{DP} = \frac{1}{2 \times \pi \times \sqrt{L \times C_{OUT}}} \quad (13)$$

The ESR zero can be calculated as shown in Equation 14.

$$f_{ESR} = \frac{1}{2 \times \pi \times ESR \times C_{OUT}} \quad (14)$$

Figure 15 and Figure 16 show the configuration of Type III compensation and typical pole and zero locations. Equation 16 through Equation 20 describe the compensator transfer function and poles and zeros of the Type III network.

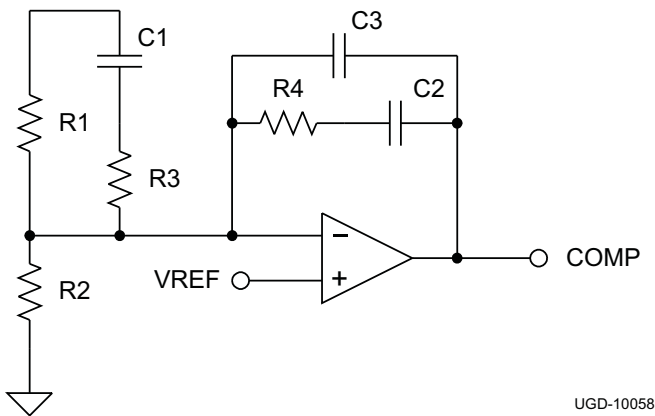

UGD-10058

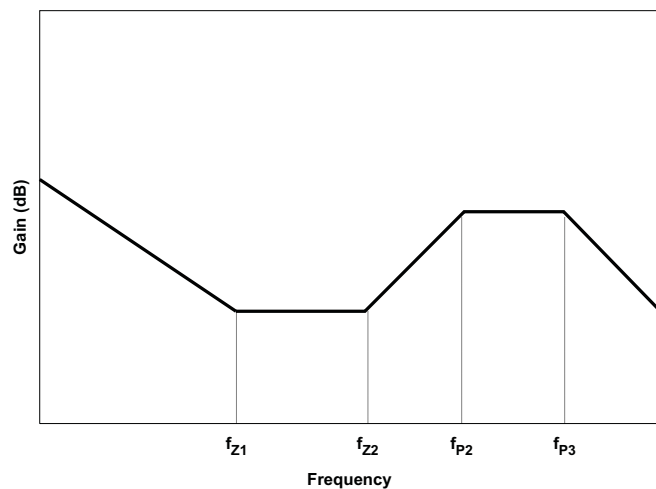

UDG-10057

Figure 15. Type III Compensation Network Configuration Schematic

Figure 16. Type III Compensation Gain Plot and Zero/Pole Placement

$$G_{EA} = \frac{(1 + s \times C_1 \times (R_1 + R_3))(1 + s \times R_4 \times C_2)}{(s \times R_1 \times (C_2 + C_3)) \times (1 + s \times C_1 \times R_3) \times \left( 1 + s \times R_4 \times \frac{C_2 \times C_3}{C_2 + C_3} \right)} \quad (15)$$

$$f_{Z1} = \frac{1}{2 \times \pi \times R_4 \times C_2} \quad (16)$$

$$f_{Z2} = \frac{1}{2 \times \pi \times (R_1 + R_3) \times C_1} \cong \frac{1}{2 \times \pi \times R_1 \times C_1} \quad (17)$$

$$f_{P1} = 0 \quad (18)$$

$$f_{P2} = \frac{1}{2 \times \pi \times R_3 \times C_1} \quad (19)$$

$$f_{P3} = \frac{1}{2 \times \pi \times R_4 \times \left( \frac{C_2 \times C_3}{C_2 + C_3} \right)} \cong \frac{1}{2 \times \pi \times R_4 \times C_3} \quad (20)$$

The two zeros can be placed near the double pole frequency to cancel the response from the double pole. One pole can be used to cancel ESR zero, and the other non-zero pole can be placed at half switching frequency to attenuate the high frequency noise and switching ripple. Suitable values can be selected to achieve a compromise between high phase margin and fast response. A phase margin higher than 45 degrees is required for stable operation.

For DCM operation, a C3 between 56 pF and 150 pF is recommended for output capacitance between 20 µF to 200 µF.

Figure 17 shows the master and slave configuration schematic for a design with a 3.3-V input.

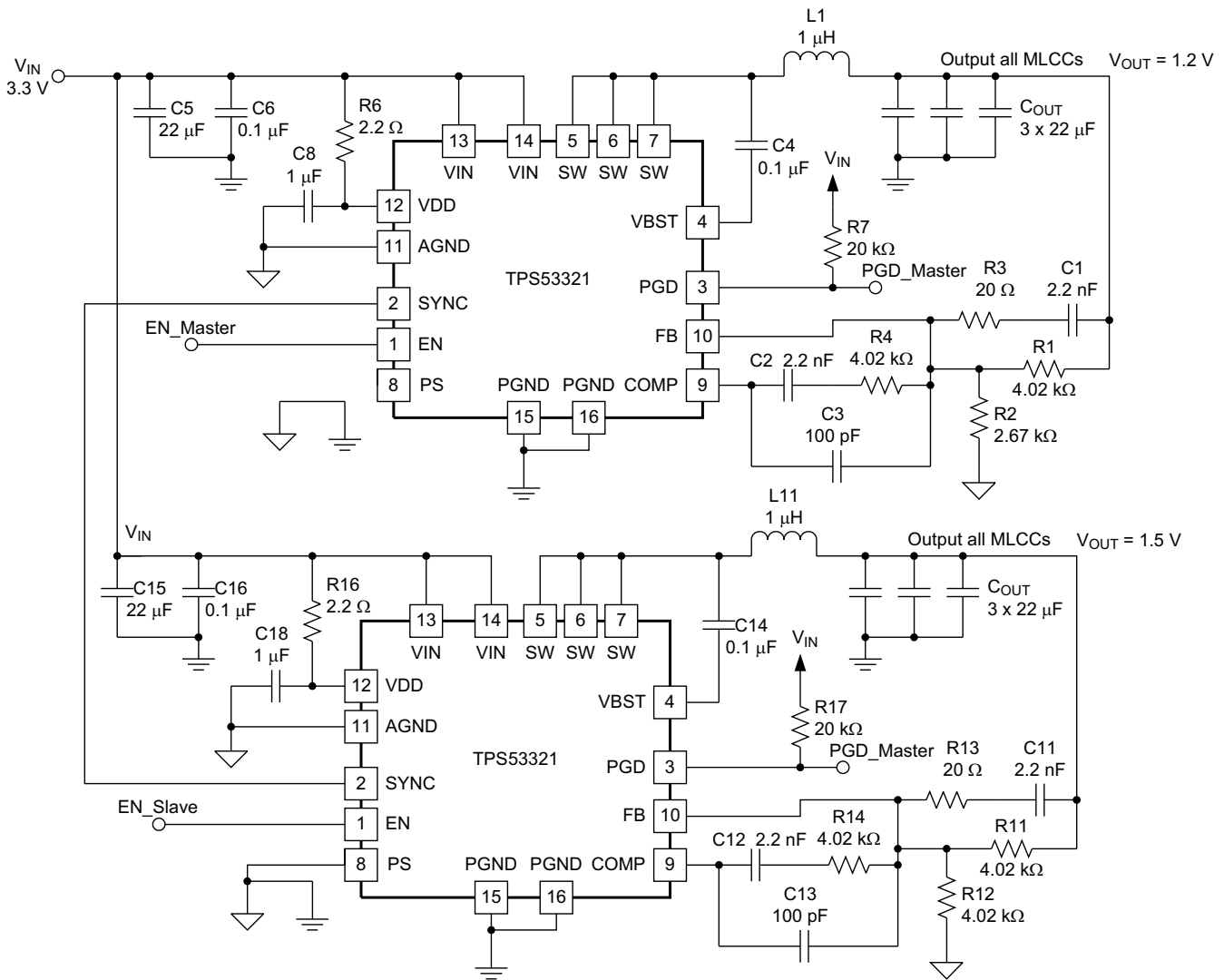

UDG-10207

Copyright © 2016, Texas Instruments Incorporated

Figure 17. Master and Slave Configuration Schematic



### 8.2.3 Application Curves

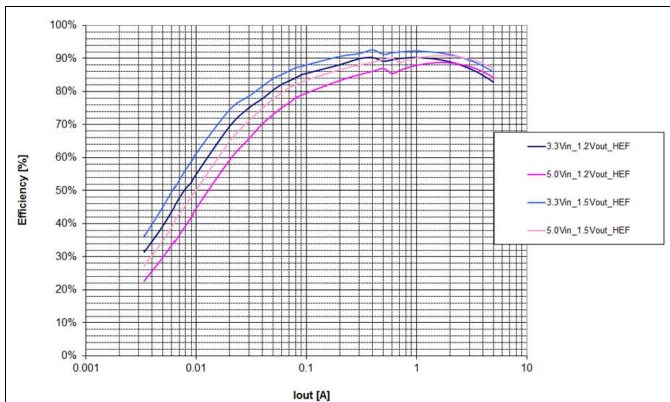

Figure 18. Efficiency

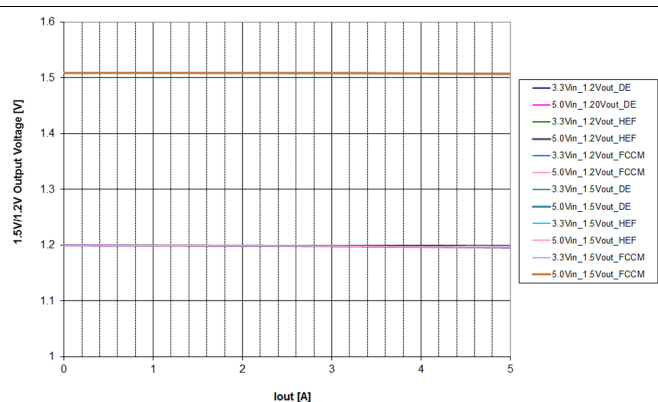

Figure 19. Load Regulation

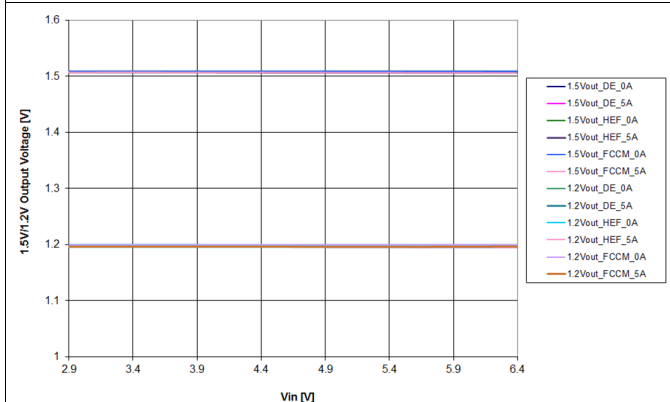

Figure 20. Line Regulation

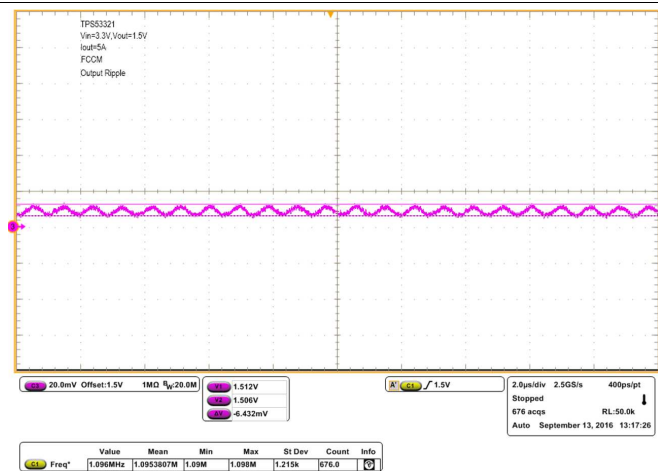

Figure 21. 1.5-V Output Ripple

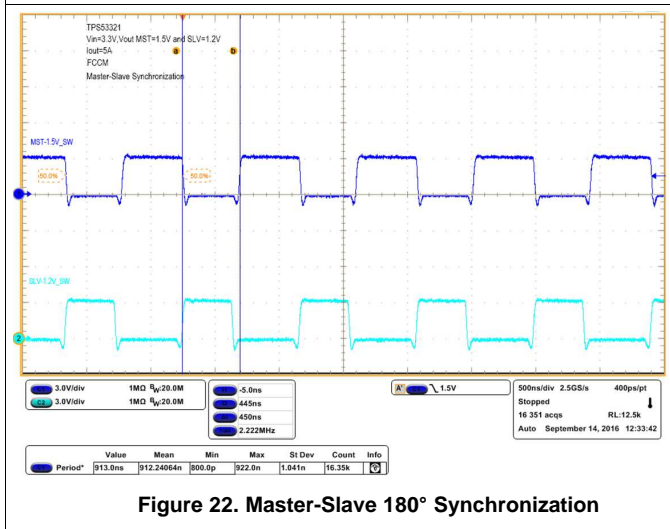

Figure 22. Master-Slave 180° Synchronization

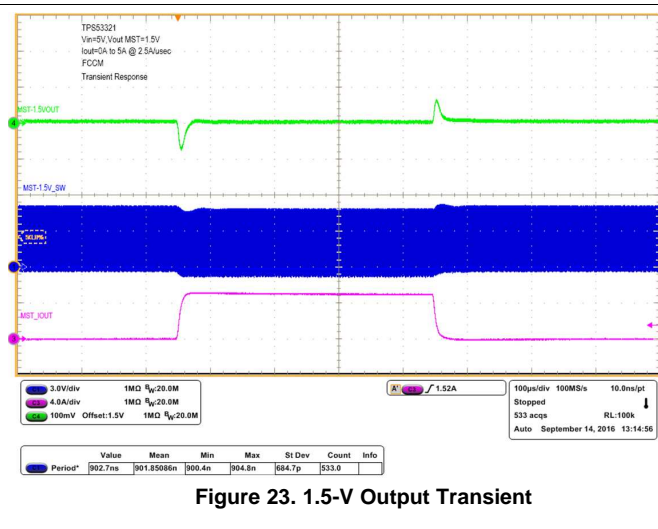
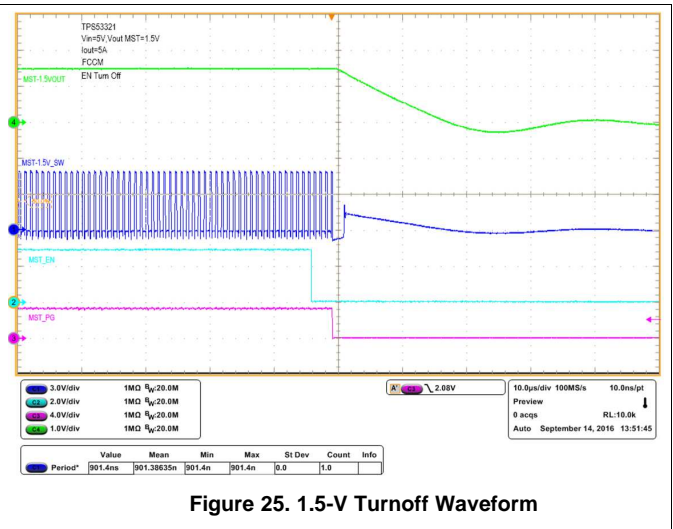
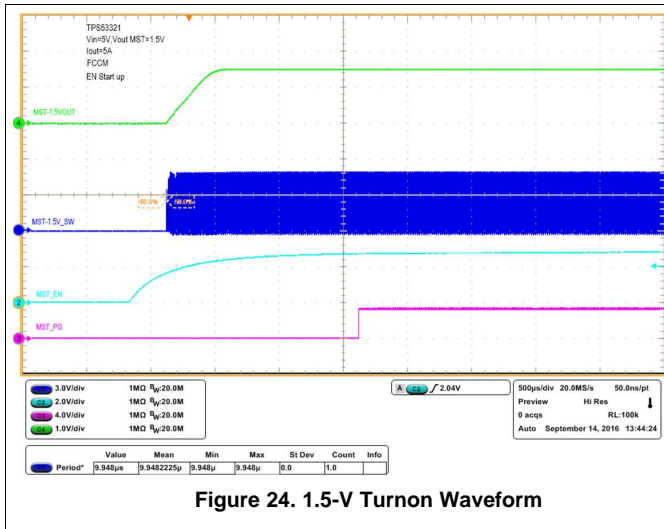

Figure 23. 1.5-V Output Transient



## 9 Power Supply Recommendations

The TPS53321 devices are designed to operate from an input voltage supply range between 2.9 V and 6 V (2.9 V to 3.5 V biased). This input supply must be well regulated. Proper bypassing of input supplies and internal regulators is also critical for noise performance, as is PCB layout and grounding scheme. See the recommendations in [Layout](#).

## 10 Layout

### 10.1 Layout Guidelines

Good layout is essential for stable power supply operation. Follow these guidelines for a clean PCB layout:

- Separate the power ground and analog ground planes. Connect them together at one location.
- Use four vias to connect the thermal pad to power ground.
- Place VIN and VDD decoupling capacitors as close to the device as possible.
- Use wide traces for  $V_{IN}$ ,  $V_{OUT}$ , PGND, and SW. These nodes carry high current and also serve as heat sinks.
- Place feedback and compensation components as close to the device as possible.
- Keep analog signals (FB, COMP) away from noisy signals (SW, SYNC, VBST).
- See TPS53321 evaluation module for a layout example.

Figure 26 shows an example layout for the TPS53321.

### 10.2 Layout Example

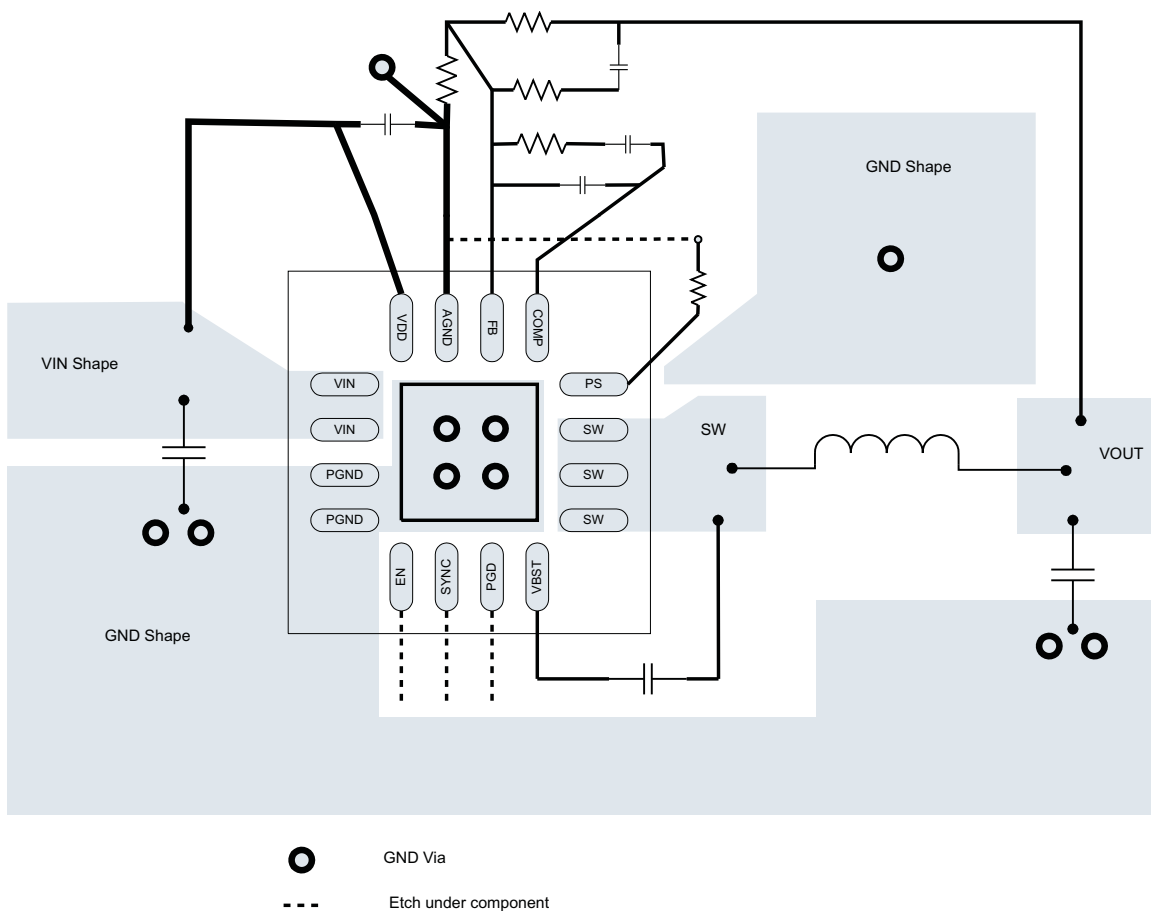

Figure 26. TPS53321 Layout Example

## 11 Device and Documentation Support

### 11.1 Receiving Notification of Documentation Updates

To receive notification of documentation updates, navigate to the device product folder on ti.com. In the upper right corner, click on *Alert me* to register and receive a weekly digest of any product information that has changed. For change details, review the revision history included in any revised document.

### 11.2 Community Resources

The following links connect to TI community resources. Linked contents are provided "AS IS" by the respective contributors. They do not constitute TI specifications and do not necessarily reflect TI's views; see TI's [Terms of Use](#).

**TI E2E™ Online Community** *TI's Engineer-to-Engineer (E2E) Community*. Created to foster collaboration among engineers. At e2e.ti.com, you can ask questions, share knowledge, explore ideas and help solve problems with fellow engineers.

**Design Support** *TI's Design Support* Quickly find helpful E2E forums along with design support tools and contact information for technical support.

### 11.3 Trademarks

SmoothPWM, Eco-Mode, E2E are trademarks of Texas Instruments. All other trademarks are the property of their respective owners.

### 11.4 Electrostatic Discharge Caution



These devices have limited built-in ESD protection. The leads should be shorted together or the device placed in conductive foam during storage or handling to prevent electrostatic damage to the MOS gates.

### 11.5 Glossary

[SLYZ022](#) — *TI Glossary*.

This glossary lists and explains terms, acronyms, and definitions.

## 12 Mechanical, Packaging, and Orderable Information

The following pages include mechanical, packaging, and orderable information. This information is the most current data available for the designated devices. This data is subject to change without notice and revision of this document. For browser-based versions of this data sheet, refer to the left-hand navigation.

**PACKAGING INFORMATION**

Orderable part number	Status (1)	Material type (2)	Package   Pins	Package qty   Carrier	RoHS (3)	Lead finish/ Ball material (4)	MSL rating/ Peak reflow (5)	Op temp (°C)	Part marking (6)
<a href="#">TPS53321RGTR</a>	Active	Production	VQFN (RGT)   16	3000   LARGE T&R	Yes	NIPDAU	Level-2-260C-1 YEAR	-40 to 85	3321
TPS53321RGTR.B	Active	Production	VQFN (RGT)   16	3000   LARGE T&R	Yes	NIPDAU	Level-2-260C-1 YEAR	-40 to 85	3321
<a href="#">TPS53321RGTT</a>	Active	Production	VQFN (RGT)   16	250   SMALL T&R	Yes	NIPDAU	Level-2-260C-1 YEAR	-40 to 85	3321
TPS53321RGTT.B	Active	Production	VQFN (RGT)   16	250   SMALL T&R	Yes	NIPDAU	Level-2-260C-1 YEAR	-40 to 85	3321

(1) **Status:** For more details on status, see our [product life cycle](#).

(2) **Material type:** When designated, preproduction parts are prototypes/experimental devices, and are not yet approved or released for full production. Testing and final process, including without limitation quality assurance, reliability performance testing, and/or process qualification, may not yet be complete, and this item is subject to further changes or possible discontinuation. If available for ordering, purchases will be subject to an additional waiver at checkout, and are intended for early internal evaluation purposes only. These items are sold without warranties of any kind.

(3) **RoHS values:** Yes, No, RoHS Exempt. See the [TI RoHS Statement](#) for additional information and value definition.

(4) **Lead finish/Ball material:** Parts may have multiple material finish options. Finish options are separated by a vertical ruled line. Lead finish/Ball material values may wrap to two lines if the finish value exceeds the maximum column width.

(5) **MSL rating/Peak reflow:** The moisture sensitivity level ratings and peak solder (reflow) temperatures. In the event that a part has multiple moisture sensitivity ratings, only the lowest level per JEDEC standards is shown. Refer to the shipping label for the actual reflow temperature that will be used to mount the part to the printed circuit board.

(6) **Part marking:** There may be an additional marking, which relates to the logo, the lot trace code information, or the environmental category of the part.

Multiple part markings will be inside parentheses. Only one part marking contained in parentheses and separated by a "~" will appear on a part. If a line is indented then it is a continuation of the previous line and the two combined represent the entire part marking for that device.

**Important Information and Disclaimer:** The information provided on this page represents TI's knowledge and belief as of the date that it is provided. TI bases its knowledge and belief on information provided by third parties, and makes no representation or warranty as to the accuracy of such information. Efforts are underway to better integrate information from third parties. TI has taken and continues to take reasonable steps to provide representative and accurate information but may not have conducted destructive testing or chemical analysis on incoming materials and chemicals. TI and TI suppliers consider certain information to be proprietary, and thus CAS numbers and other limited information may not be available for release.

In no event shall TI's liability arising out of such information exceed the total purchase price of the TI part(s) at issue in this document sold by TI to Customer on an annual basis.

**TAPE AND REEL INFORMATION**

**QUADRANT ASSIGNMENTS FOR PIN 1 ORIENTATION IN TAPE**

\*All dimensions are nominal

Device	Package Type	Package Drawing	Pins	SPQ	Reel Diameter (mm)	Reel Width W1 (mm)	A0 (mm)	B0 (mm)	K0 (mm)	P1 (mm)	W (mm)	Pin1 Quadrant
TPS53321RGTR	VQFN	RGT	16	3000	330.0	12.4	3.3	3.3	1.1	8.0	12.0	Q2
TPS53321RGTT	VQFN	RGT	16	250	180.0	12.4	3.3	3.3	1.1	8.0	12.0	Q2

**TAPE AND REEL BOX DIMENSIONS**

\*All dimensions are nominal

Device	Package Type	Package Drawing	Pins	SPQ	Length (mm)	Width (mm)	Height (mm)
TPS53321RGTR	VQFN	RGT	16	3000	367.0	367.0	35.0
TPS53321RGTT	VQFN	RGT	16	250	210.0	185.0	35.0

**RGT 16**

**GENERIC PACKAGE VIEW**

**VQFN - 1 mm max height**

PLASTIC QUAD FLATPACK - NO LEAD

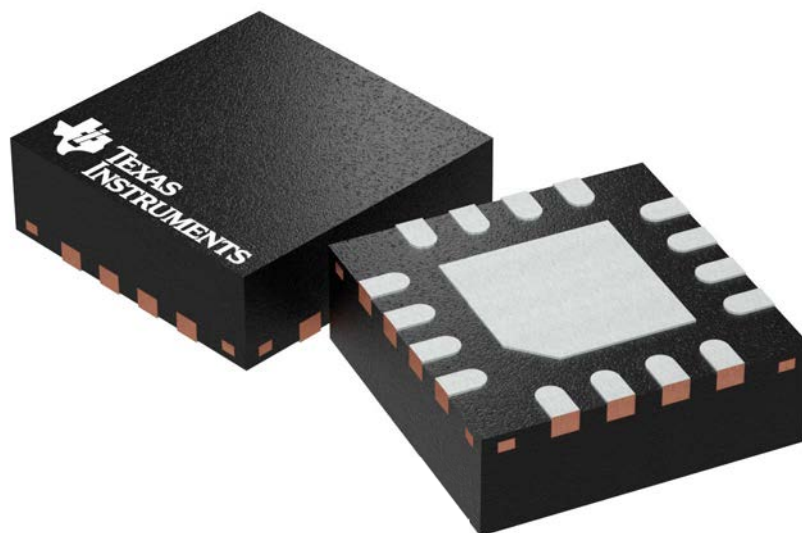

Images above are just a representation of the package family, actual package may vary.  
Refer to the product data sheet for package details.

4203495/1



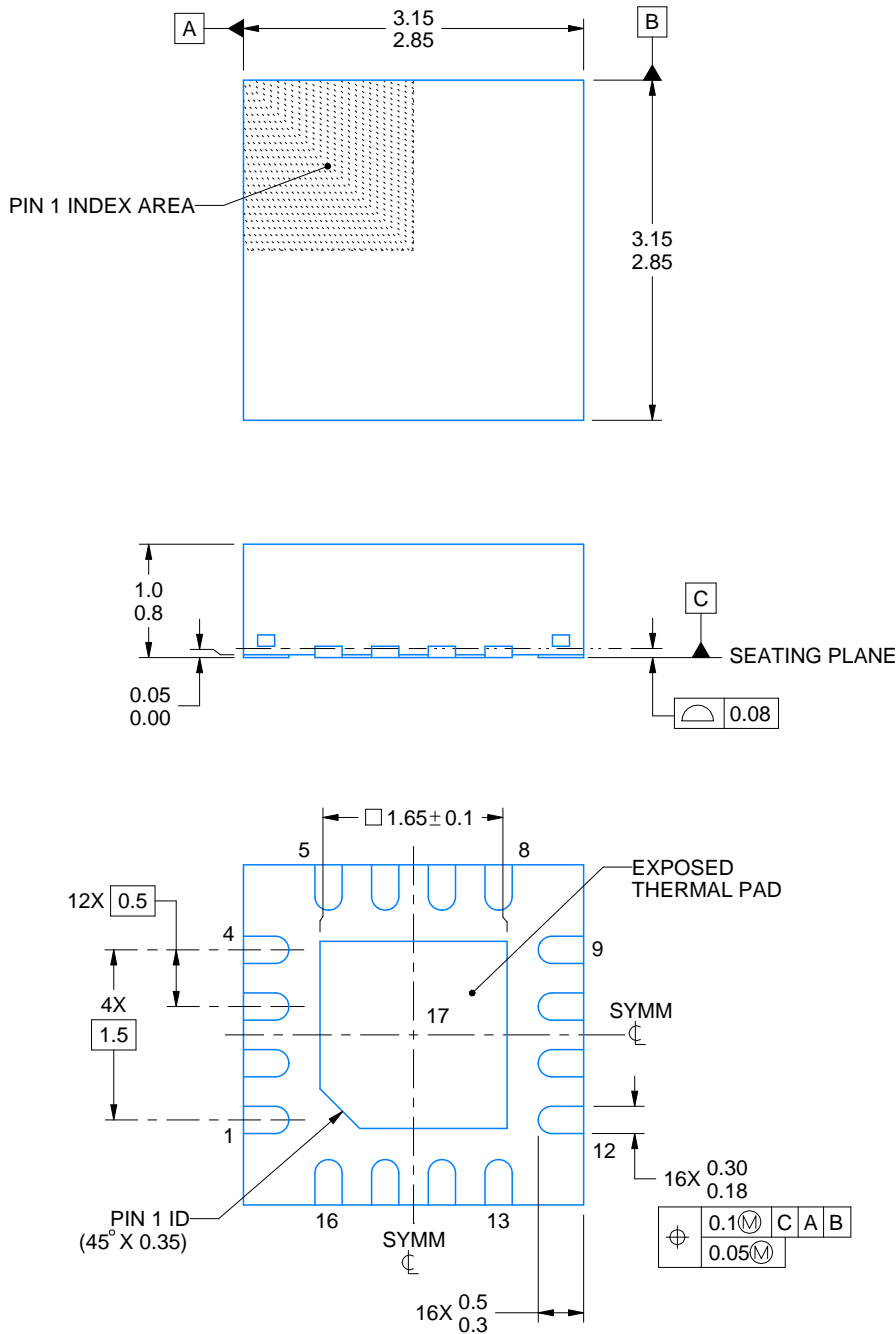
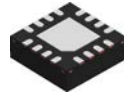

4230572/A 07/2025

NOTES:

1. All linear dimensions are in millimeters. Any dimensions in parenthesis are for reference only. Dimensioning and tolerancing per ASME Y14.5M.
2. This drawing is subject to change without notice.
3. The package thermal pad must be soldered to the printed circuit board for thermal and mechanical performance.

# EXAMPLE BOARD LAYOUT

RGT0016F

VQFN - 1 mm max height

PLASTIC QUAD FLATPACK - NO LEAD

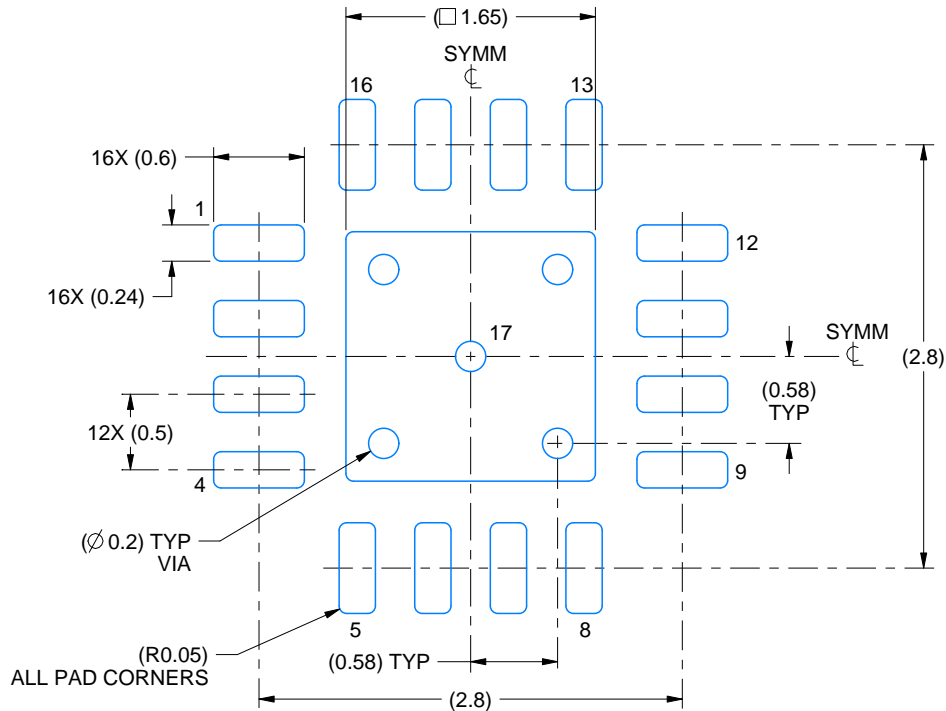

LAND PATTERN EXAMPLE  
EXPOSED METAL SHOWN  
SCALE:20X

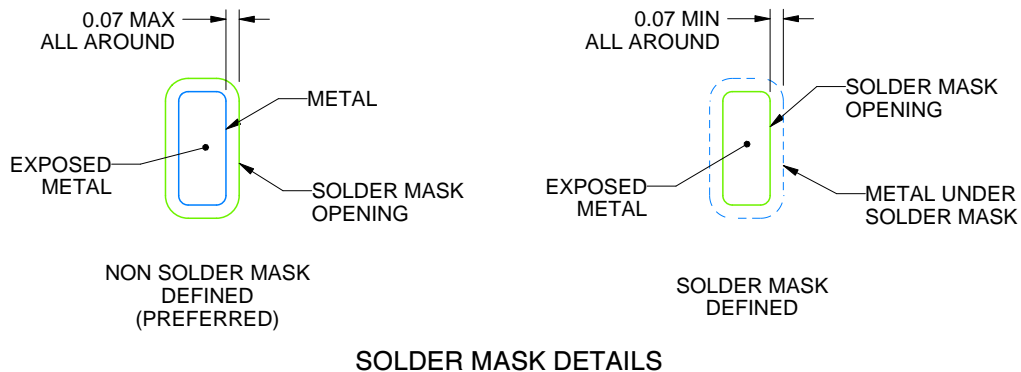

SOLDER MASK DETAILS

4230572/A 07/2025

NOTES: (continued)

4. This package is designed to be soldered to a thermal pad on the board. For more information, see Texas Instruments literature number SLUA271 ([www.ti.com/lit/slua271](http://www.ti.com/lit/slua271)).
5. Vias are optional depending on application, refer to device data sheet. If any vias are implemented, refer to their locations shown on this view. It is recommended that vias under paste be filled, plugged or tented.

# EXAMPLE STENCIL DESIGN

RGT0016F

VQFN - 1 mm max height

PLASTIC QUAD FLATPACK - NO LEAD

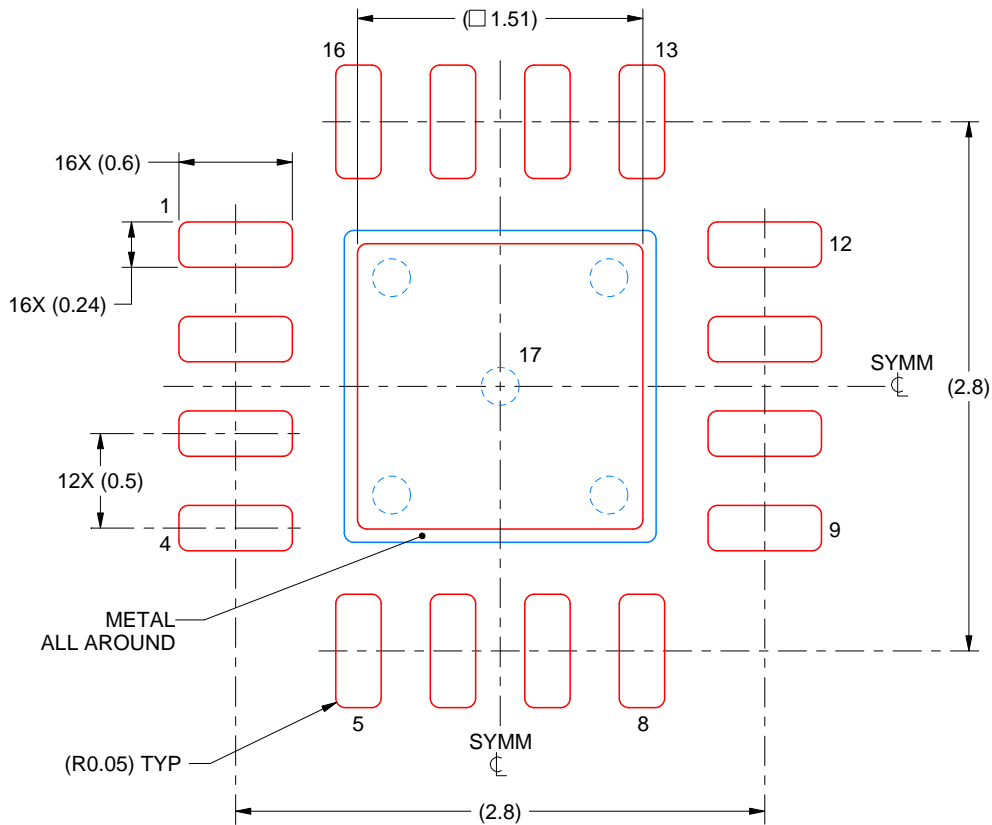

**SOLDER PASTE EXAMPLE**  
BASED ON 0.125 mm THICK STENCIL

EXPOSED PAD 17:  
84% PRINTED SOLDER COVERAGE BY AREA UNDER PACKAGE  
SCALE:25X

4230572/A 07/2025

NOTES: (continued)

6. Laser cutting apertures with trapezoidal walls and rounded corners may offer better paste release. IPC-7525 may have alternate design recommendations.

## IMPORTANT NOTICE AND DISCLAIMER

TI PROVIDES TECHNICAL AND RELIABILITY DATA (INCLUDING DATASHEETS), DESIGN RESOURCES (INCLUDING REFERENCE DESIGNS), APPLICATION OR OTHER DESIGN ADVICE, WEB TOOLS, SAFETY INFORMATION, AND OTHER RESOURCES "AS IS" AND WITH ALL FAULTS, AND DISCLAIMS ALL WARRANTIES, EXPRESS AND IMPLIED, INCLUDING WITHOUT LIMITATION ANY IMPLIED WARRANTIES OF MERCHANTABILITY, FITNESS FOR A PARTICULAR PURPOSE OR NON-INFRINGEMENT OF THIRD PARTY INTELLECTUAL PROPERTY RIGHTS.

These resources are intended for skilled developers designing with TI products. You are solely responsible for (1) selecting the appropriate TI products for your application, (2) designing, validating and testing your application, and (3) ensuring your application meets applicable standards, and any other safety, security, regulatory or other requirements.

These resources are subject to change without notice. TI grants you permission to use these resources only for development of an application that uses the TI products described in the resource. Other reproduction and display of these resources is prohibited. No license is granted to any other TI intellectual property right or to any third party intellectual property right. TI disclaims responsibility for, and you fully indemnify TI and its representatives against any claims, damages, costs, losses, and liabilities arising out of your use of these resources.

TI's products are provided subject to [TI's Terms of Sale](#), [TI's General Quality Guidelines](#), or other applicable terms available either on [ti.com](#) or provided in conjunction with such TI products. TI's provision of these resources does not expand or otherwise alter TI's applicable warranties or warranty disclaimers for TI products. Unless TI explicitly designates a product as custom or customer-specified, TI products are standard, catalog, general purpose devices.

TI objects to and rejects any additional or different terms you may propose.

Copyright © 2025, Texas Instruments Incorporated

Last updated 10/2025