

TPS791

Ultralow Noise, High PSRR, Fast RF 100-mA Low-Dropout Linear Regulators

1 Features

- 100-mA Low-Dropout Regulator With $\overline{\text{EN}}$
- Available in 1.8-V, 3.3-V, 4.7-V, and Adj.
- High PSRR (70 dB at 10 kHz)
- Ultralow Noise (15 μV_{RMS})
- Fast Start-Up Time (63 μs)
- Stable With Any 1- μF Ceramic Capacitor
- Excellent Load, Line Transient
- Very Low Dropout Voltage (38 mV at Full Load, TPS79147)
- 5-Pin SOT23 (DBV) Package
- TPS792xx Provides EN Options

2 Applications

- Powering VCOs and PLLs
- Bluetooth and Wireless LAN
- Portable and Battery Operated

3 Description

The TPS791 device is a low-dropout (LDO) low-power linear voltage regulator that features high power-supply rejection ratio (PSRR), ultralow noise, fast start-up, and excellent line and load transient responses in a small outline, SOT23 package. The device is stable, with a small 1- μF ceramic capacitor on the output. The TPS791 uses an advanced, proprietary BiCMOS fabrication process to yield extremely low dropout voltages (for example, 38 mV at 100 mA, TPS79147). This device achieves fast start-up times (approximately 63 μs with a 0.001- μF bypass capacitor) while consuming very low quiescent current (170 μA typical). Moreover, when the device is placed in standby mode, the supply current is reduced to less than 1 μA . The TPS79118 exhibits approximately 15 μV_{RMS} of output voltage noise with a 0.1- μF bypass capacitor. Applications with analog components that are noise sensitive, such as portable RF electronics, benefit from the high PSRR and low noise features as well as the fast response time.

Device Information⁽¹⁾

PART NUMBER	PACKAGE	BODY SIZE (NOM)
TPS791	SOT23 (5)	2.90 mm x 1.60 mm
	SOT23 (6)	2.90 mm x 1.60 mm

(1) For all available packages, see the orderable addendum at the end of the data sheet.

Simplified Schematic: Fixed Output

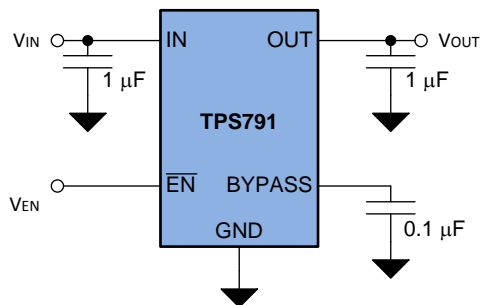

Copyright © 2018, Texas Instruments Incorporated

Simplified Schematic: Adjustable Output

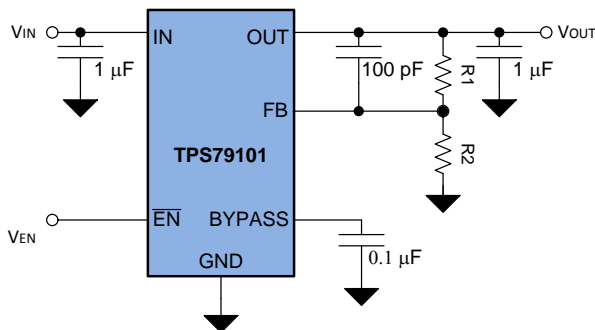

Copyright © 2017, Texas Instruments Incorporated



Table of Contents

1 Features	1	7.4 Device Functional Modes.....	15
2 Applications	1	8 Application and Implementation	16
3 Description	1	8.1 Application Information.....	16
4 Revision History	2	8.2 Typical Application	16
5 Pin Configuration and Functions	3	8.3 Do's and Don'ts.....	17
6 Specifications	3	9 Power Supply Recommendations	18
6.1 Absolute Maximum Ratings	3	10 Layout	18
6.2 ESD Ratings.....	4	10.1 Layout Guidelines	18
6.3 Recommended Operating Conditions.....	4	10.2 Layout Example	18
6.4 Thermal Information	4	11 Device and Documentation Support	19
6.5 Electrical Characteristics.....	5	11.1 Receiving Notification of Documentation Updates	19
6.6 Typical Characteristics	6	11.2 Community Resources.....	19
7 Detailed Description	12	11.3 Trademarks	19
7.1 Overview	12	11.4 Electrostatic Discharge Caution.....	19
7.2 Functional Block Diagrams	12	11.5 Glossary	19
7.3 Feature Description.....	13	12 Mechanical, Packaging, and Orderable Information	19

4 Revision History

NOTE: Page numbers for previous revisions may differ from page numbers in the current version.

Changes from Revision C (May 2002) to Revision D	Page
• Added <i>Device Information</i> table, <i>Simplified Schematic</i> figures to page 1, <i>ESD Ratings</i> table, <i>Thermal Information</i> table, <i>Pin Configuration and Functions</i> section, <i>Overview</i> section, <i>Feature Description</i> section, <i>Device Functional Modes</i> section, <i>Application and Implementation</i> section, <i>Power Supply Recommendations</i> section, <i>Layout</i> section, <i>Device and Documentation Support</i> section, and <i>Mechanical, Packaging, and Orderable Information</i> section	1
• Changed <i>TPS791xx</i> to <i>TPS791</i> throughout document	1
• Changed <i>Applications</i> section	1
• Changed <i>Description</i> section	1
• Deleted <i>Ordering Information</i> table	3
• Changed $\overline{\text{EN}}$ pin description	3
• Added I/O data for GND pin	3
• Deleted <i>Package Dissipation Rating</i> table	3
• Changed V_I to V_{IN} , I_O to I_{OUT} , C_O to C_{OUT} , $C_{O(byp)}$ and $C_{(byp)}$ to C_{BYPASS} throughout document	3
• Changed formula in footnote 1 of <i>Recommended Operating Conditions</i> table.....	4
• Added V_{REF} parameter to <i>Electrical Characteristics</i> table.....	5
• Changed V_{CC} to V_{IN} in test conditions of <i>UVLO threshold</i> and <i>UVLO hysteresis</i> parameters.....	5
• Added PSRR and V_{DO} symbols to <i>Power-supply ripple rejection</i> and <i>Dropout voltage</i> parameters.....	5
• Added conditions statement to <i>Typical Characteristics</i> section	6
• Changed I_{OUT} to C_{BYPASS} in <i>TPS79118 Output Spectral Noise Density vs Frequency</i> figure	7
• Changed I_{OUT} to C_{BYPASS} in <i>TPS79133 Output Spectral Noise Density vs Frequency</i> figure	7
• Changed third bullet in <i>Normal Operation</i> section	15
• Changed first bullet in <i>Disabled</i> section	15
• Changed V_{EN} column in <i>Device Functional Mode Comparison</i> table.....	15
• Added <i>active-low</i> to <i>Application Information</i> description	16

5 Pin Configuration and Functions

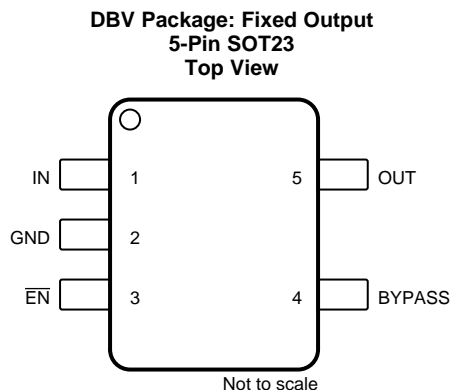
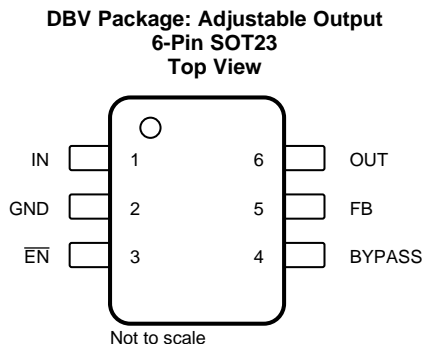

Pin Functions

NAME	PIN		I/O	DESCRIPTION
	ADJ	FIXED		
BYPASS	4	4	—	An external bypass capacitor connected to this pin, in conjunction with an internal resistor, creates a low-pass filter to further reduce regulator noise.
$\overline{\text{EN}}$	3	3	I	The $\overline{\text{EN}}$ pin is an input which enables or shuts down the device. The enable signal is an active-low digital control that enables the device, so when $\overline{\text{EN}}$ is a logic high (> 2 V), the device is in shutdown mode. When $\overline{\text{EN}}$ is logic low (< 0.7 V), the device is enabled.
FB	5	N/A	I	This pin is the feedback input voltage for the adjustable device.
GND	2	2	—	Regulator ground.
IN	1	1	I	The IN pin is the input to the device.
OUT	6	5	O	The OUT pin is the regulated output of the device.

6 Specifications

6.1 Absolute Maximum Ratings

over operating free-air temperature range (unless otherwise noted)⁽¹⁾

	MIN	MAX	UNIT
Input voltage range ⁽²⁾	−0.3	6	V
Voltage range at $\overline{\text{EN}}$	−0.3	$V_{\text{IN}} + 0.3$	V
Voltage on OUT	−0.3	6	V
Peak output current	Internally limited		
Continuous total power dissipation	See Thermal Information table		
Operating virtual junction temperature, T_{J}	−40	150	°C
Operating ambient temperature, T_{A}	−40	85	°C
Storage temperature, T_{stg}	−65	150	°C

- (1) Stresses beyond those listed under *Absolute Maximum Ratings* may cause permanent damage to the device. These are stress ratings only, which do not imply functional operation of the device at these or any other conditions beyond those indicated under *Recommended Operating Conditions*. Exposure to absolute-maximum-rated conditions for extended periods may affect device reliability.
- (2) All voltage values are with respect to the network ground pin.

6.2 ESD Ratings

		VALUE	UNIT
V _(ESD)	Electrostatic discharge	Human-body model (HBM), per ANSI/ESDA/JEDEC JS-001 ⁽¹⁾	±2000
		Charged-device model (CDM), per JEDEC specification JESD22-C101 ⁽²⁾	±500

(1) JEDEC document JEP155 states that 500-V HBM allows safe manufacturing with a standard ESD control process.

(2) JEDEC document JEP157 states that 250-V CDM allows safe manufacturing with a standard ESD control process.

6.3 Recommended Operating Conditions

over operating free-air temperature range (unless otherwise noted)

		MIN	NOM	MAX	UNIT
V _{IN}	Input voltage ⁽¹⁾	2.7		5.5	V
I _{OUT}	Continuous output current ⁽²⁾	0		100	mA
T _J	Operating junction temperature	–40		125	°C

(1) To calculate the minimum input voltage for your maximum output current, use the following formula:

$$V_{IN(min)} = V_{OUT(max)} + \text{dropout voltage } (V_{DO}) \text{ at maximum load.}$$

(2) Continuous output current and operating junction temperature are limited by internal protection circuitry, but the device is not recommended to be operated under conditions beyond those specified in this table for extended periods of time.

6.4 Thermal Information

THERMAL METRIC ⁽¹⁾		TPS791		UNIT
		DBV (SOT23)	DBV (SOT23)	
		5 PINS	6 PINS	
R _{θJA}	Junction-to-ambient thermal resistance	192.6	168.2	°C/W
R _{θJC(top)}	Junction-to-case (top) thermal resistance	104.2	87.1	°C/W
R _{θJB}	Junction-to-board thermal resistance	55.2	36.9	°C/W
ψ _{JT}	Junction-to-top characterization parameter	24.1	17.1	°C/W
ψ _{JB}	Junction-to-board characterization parameter	54.8	36.6	°C/W
R _{θJC(bot)}	Junction-to-case (bottom) thermal resistance	N/A	N/A	°C/W

(1) For more information about traditional and new thermal metrics, see the [Semiconductor and IC Package Thermal Metrics](#) application report.

6.5 Electrical Characteristics

over recommended operating free-air temperature range, ($T_J = -40^\circ\text{C}$ to 125°C), $V_{IN} = V_{OUT(\text{typ})} + 1\text{ V}$, $I_{OUT} = 1\text{ mA}$, $\overline{\text{EN}} = 0\text{ V}$, $C_{OUT} = 10\text{ }\mu\text{F}$, $C_{\text{BYPASS}} = 0.01\text{ }\mu\text{F}$ (unless otherwise noted)

PARAMETER		TEST CONDITIONS	MIN	TYP	MAX	UNIT
Output voltage	TPS79101	$T_J = 25^\circ\text{C}$, $1.22\text{ V} \leq V_{OUT} \leq 5.2\text{ V}$	V_{OUT}			V
		$0\text{ }\mu\text{A} < I_{OUT} < 100\text{ mA}^{(1)}$, $1.22\text{ V} \leq V_{OUT} \leq 5.2\text{ V}$	0.98 V_{OUT}		1.02 V_{OUT}	
	TPS79118	$T_J = 25^\circ\text{C}$	1.8			
		$0\text{ }\mu\text{A} < I_{OUT} < 100\text{ mA}$, $2.8\text{ V} < V_{IN} < 5.5\text{ V}$	1.764		1.836	
	TPS79133	$T_J = 25^\circ\text{C}$	3.3			
		$0\text{ }\mu\text{A} < I_{OUT} < 100\text{ mA}$, $4.3\text{ V} < V_{IN} < 5.5\text{ V}$	3.234		3.366	
TPS79147	$T_J = 25^\circ\text{C}$	4.7				
	$0\text{ }\mu\text{A} < I_{OUT} < 100\text{ mA}$, $5.2\text{ V} < V_{IN} < 5.5\text{ V}$	4.606		4.794		
VREF	Reference voltage		1.2246			V
Quiescent current (GND current)		$0\text{ }\mu\text{A} < I_{OUT} < 100\text{ mA}$, $T_J = 25^\circ\text{C}$	170			μA
		$0\text{ }\mu\text{A} < I_{OUT} < 100\text{ mA}$	250			
Load regulation		$0\text{ }\mu\text{A} < I_{OUT} < 100\text{ mA}$, $T_J = 25^\circ\text{C}$	5			mV
$\frac{\Delta V_{OUT}}{V_{OUT}}$	Output voltage line regulation ⁽²⁾	$V_{OUT} + 1\text{ V} < V_{IN} \leq 5.5\text{ V}$, $T_J = 25^\circ\text{C}$	0.05			%/V
		$V_{OUT} + 1\text{ V} < V_{IN} \leq 5.5\text{ V}$	0.12			
Output noise voltage (TPS79118)		BW = 100 Hz to 100 kHz, $I_{OUT} = 100\text{ mA}$, $T_J = 25^\circ\text{C}$	$C_{\text{BYPASS}} = 0.001\text{ }\mu\text{F}$	32		μV_{RMS}
			$C_{\text{BYPASS}} = 0.0047\text{ }\mu\text{F}$	17		
			$C_{\text{BYPASS}} = 0.01\text{ }\mu\text{F}$	16		
			$C_{\text{BYPASS}} = 0.1\text{ }\mu\text{F}$	15		
Time, start-up (TPS79133)		$R_L = 33\text{ }\Omega$, $C_{OUT} = 1\text{ }\mu\text{F}$, $T_J = 25^\circ\text{C}$	$C_{\text{BYPASS}} = 0.001\text{ }\mu\text{F}$	53		μs
			$C_{\text{BYPASS}} = 0.0047\text{ }\mu\text{F}$	67		
			$C_{\text{BYPASS}} = 0.01\text{ }\mu\text{F}$	98		
Output current limit		$V_{OUT} = 0\text{ V}^{(1)}$	285		600	mA
UVLO threshold		V_{IN} rising	2.25		2.65	V
UVLO hysteresis		$T_J = 25^\circ\text{C}$, V_{IN} rising	100			mV
Standby current		$\overline{\text{EN}} = V_{IN}$, $2.7\text{ V} < V_{IN} < 5.5\text{ V}$		0.07	1	μA
High level enable input voltage		$2.7\text{ V} < V_{IN} < 5.5\text{ V}$	2			V
Low level enable input voltage		$2.7\text{ V} < V_{IN} < 5.5\text{ V}$	0.7			V
Input current ($\overline{\text{EN}}$)		$\overline{\text{EN}} = V_{IN}$	-1		1	μA
PSRR	Power-supply ripple rejection	TPS79118	$f = 100\text{ Hz}$, $T_J = 25^\circ\text{C}$, $I_{OUT} = 10\text{ mA}$	80		dB
			$f = 100\text{ Hz}$, $T_J = 25^\circ\text{C}$, $I_{OUT} = 100\text{ mA}$	75		
			$f = 10\text{ kHz}$, $T_J = 25^\circ\text{C}$, $I_{OUT} = 100\text{ mA}$	72		
			$f = 100\text{ kHz}$, $T_J = 25^\circ\text{C}$, $I_{OUT} = 100\text{ mA}$	45		
		TPS79133	$f = 100\text{ Hz}$, $T_J = 25^\circ\text{C}$, $I_{OUT} = 10\text{ mA}$	70		
			$f = 100\text{ Hz}$, $T_J = 25^\circ\text{C}$, $I_{OUT} = 100\text{ mA}$	75		
			$f = 10\text{ kHz}$, $T_J = 25^\circ\text{C}$, $I_{OUT} = 100\text{ mA}$	73		
V _{DO}	Dropout voltage ⁽³⁾	TPS79133	$I_{OUT} = 100\text{ mA}$, $T_J = 25^\circ\text{C}$	50		mV
			$I_{OUT} = 100\text{ mA}$	90		
		TPS79147	$I_{OUT} = 100\text{ mA}$, $T_J = 25^\circ\text{C}$	38		
			$I_{OUT} = 100\text{ mA}$	70		

(1) The minimum V_{IN} operating voltage is 2.7 V or $V_{OUT(\text{typ})} + 1\text{ V}$, whichever is greater. The maximum V_{IN} voltage is 5.5 V . The maximum output current is 100 mA .

(2) If $V_{OUT} \leq 1.8\text{ V}$ then $V_{IN\text{min}} = 2.7\text{ V}$ and $V_{IN\text{max}} = 5.5\text{ V}$.

(3) Equals V_{IN} voltage – $V_{OUT(\text{typ})} - 100\text{ mV}$; the TPS79118 dropout voltage is limited by the minimum input voltage range limitations.

6.6 Typical Characteristics

at $T_J = 25^\circ\text{C}$, $V_{IN} = V_{OUT(\text{typ})} + 1\text{ V}$, $I_{OUT} = 1\text{ mA}$, $EN = 0\text{ V}$, $C_{OUT} = 10\text{ }\mu\text{F}$, and $C_{\text{BYPASS}} = 0.01\text{ }\mu\text{F}$ (unless otherwise noted)

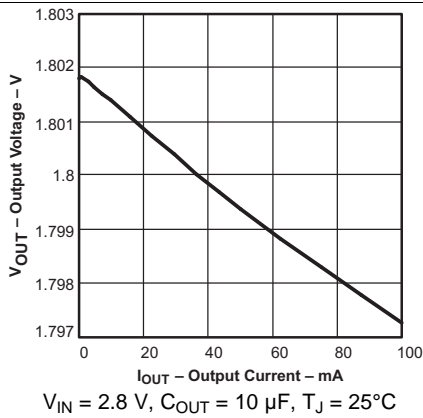

Figure 1. TPS79118 Output Voltage vs Output Current

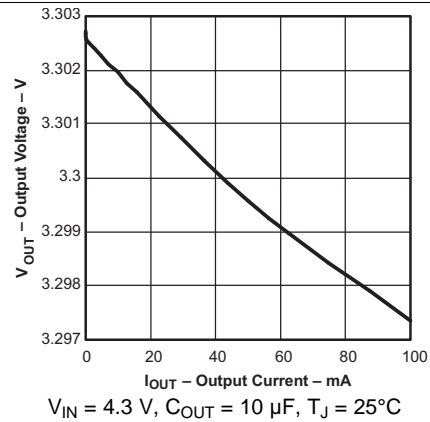

Figure 2. TPS79133 Output Voltage vs Output Current

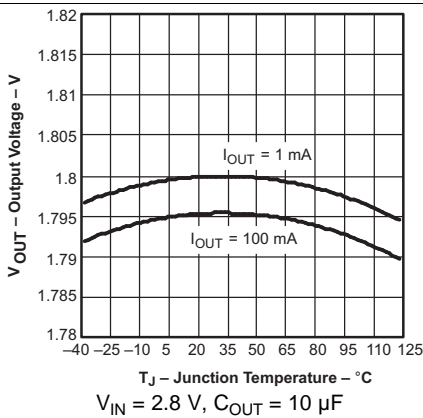

Figure 3. TPS79118 Output Voltage vs Junction Temperature

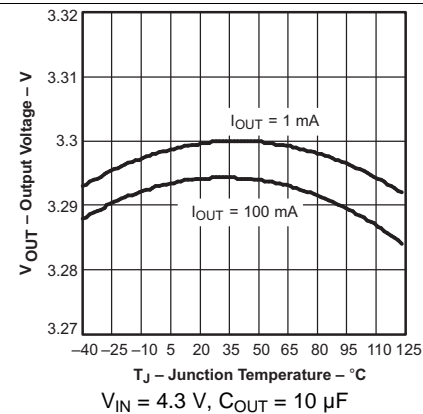

Figure 4. TPS79133 Output Voltage vs Junction Temperature

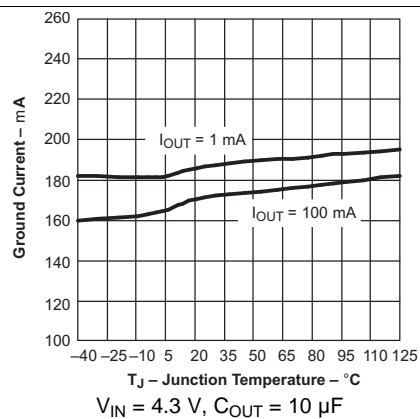

Figure 5. TPS79133 Ground Current vs Junction Temperature

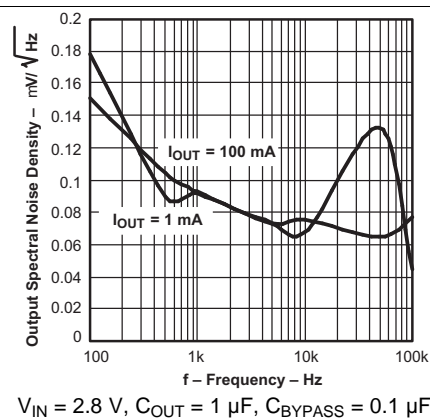
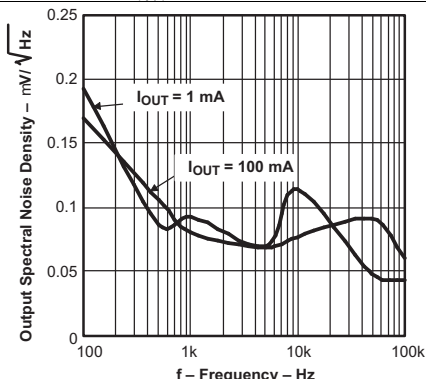

Figure 6. TPS79118 Output Spectral Noise Density vs Frequency

Typical Characteristics (continued)

at $T_J = 25^\circ\text{C}$, $V_{IN} = V_{OUT(\text{typ})} + 1\text{ V}$, $I_{OUT} = 1\text{ mA}$, $EN = 0\text{ V}$, $C_{OUT} = 10\text{ }\mu\text{F}$, and $C_{BYPASS} = 0.01\text{ }\mu\text{F}$ (unless otherwise noted)



$V_{IN} = 2.8\text{ V}$, $C_{OUT} = 10\text{ }\mu\text{F}$, $C_{BYPASS} = 0.1\text{ }\mu\text{F}$

Figure 7. TPS79118 Output Spectral Noise Density vs Frequency

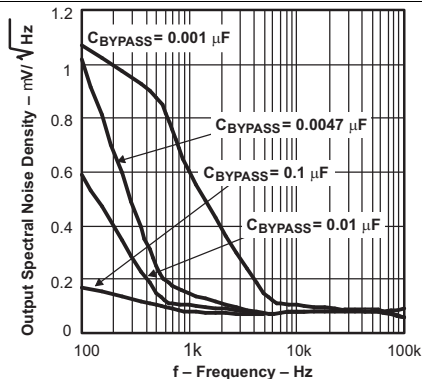

$V_{IN} = 2.8\text{ V}$, $I_{OUT} = 100\text{ mA}$, $C_{OUT} = 10\text{ }\mu\text{F}$

Figure 8. TPS79118 Output Spectral Noise Density vs Frequency

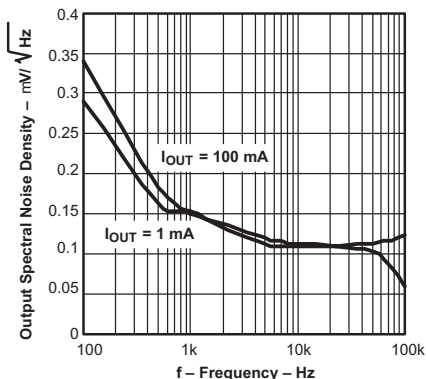

$V_{IN} = 4.3\text{ V}$, $C_{OUT} = 1\text{ }\mu\text{F}$, $C_{BYPASS} = 0.1\text{ }\mu\text{F}$

Figure 9. TPS79133 Output Spectral Noise Density vs Frequency

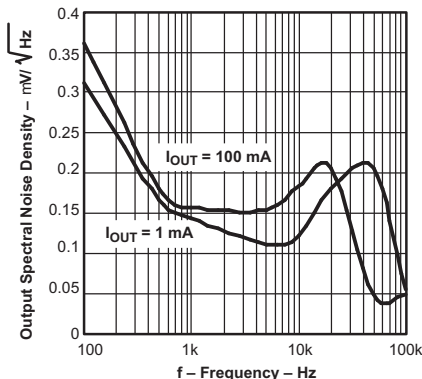

$V_{IN} = 4.3\text{ V}$, $C_{OUT} = 10\text{ }\mu\text{F}$, $C_{BYPASS} = 0.1\text{ }\mu\text{F}$

Figure 10. TPS79133 Output Spectral Noise Density vs Frequency

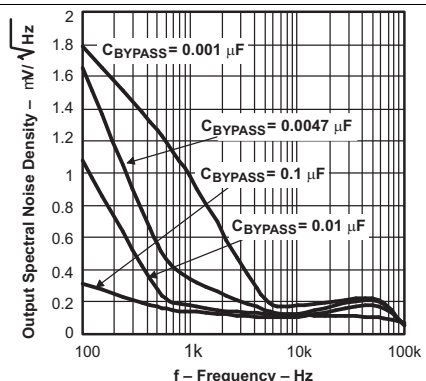

$V_{IN} = 4.3\text{ V}$, $I_{OUT} = 100\text{ mA}$, $C_{OUT} = 10\text{ }\mu\text{F}$

Figure 11. TPS79133 Output Spectral Noise Density vs Frequency

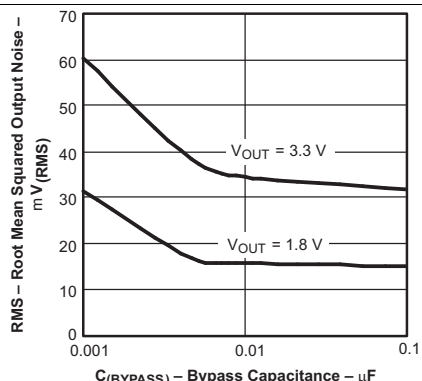

$C_{(BYPASS)}$ – Bypass Capacitance – μF
 BW = 100 Hz to 100 kHz

Figure 12. Root Mean Squared Output Noise vs Bypass Capacitance

Typical Characteristics (continued)

at $T_J = 25^\circ\text{C}$, $V_{IN} = V_{OUT(\text{typ})} + 1\text{ V}$, $I_{OUT} = 1\text{ mA}$, $EN = 0\text{ V}$, $C_{OUT} = 10\text{ }\mu\text{F}$, and $C_{BYPASS} = 0.01\text{ }\mu\text{F}$ (unless otherwise noted)

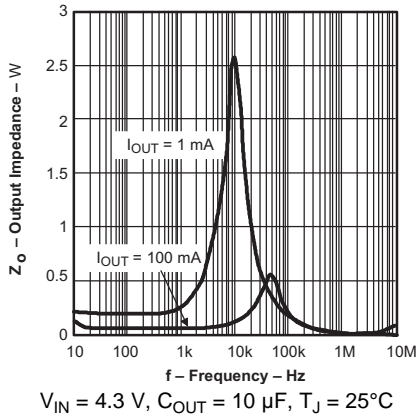

Figure 13. TPS79133 Output Impedance vs Frequency

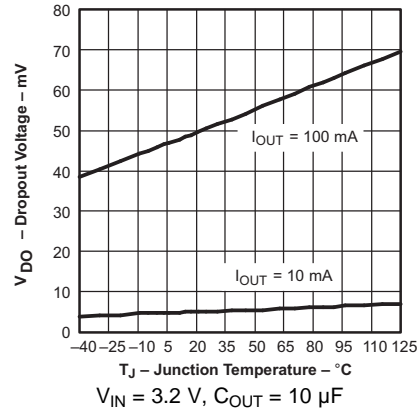

Figure 14. TPS79133 Dropout Voltage vs Junction Temperature

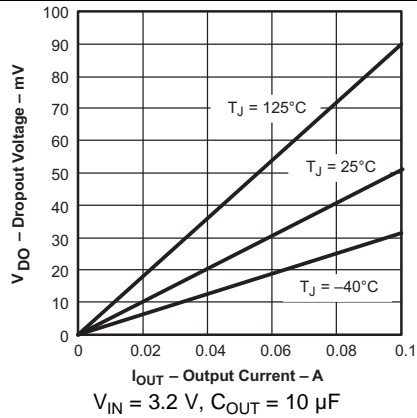

Figure 15. TPS79133 Dropout Voltage vs Output Current

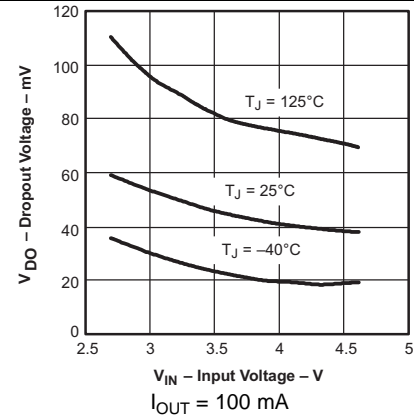

Figure 16. TPS79101 Dropout Voltage vs Input Voltage

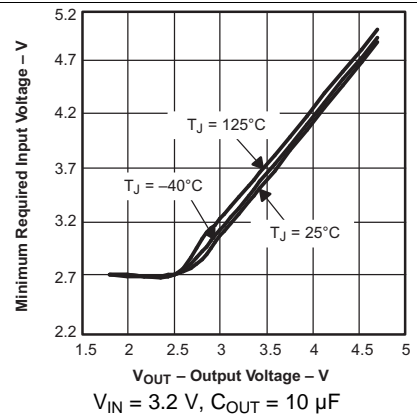

Figure 17. Minimum Required Input Voltage vs Output Voltage

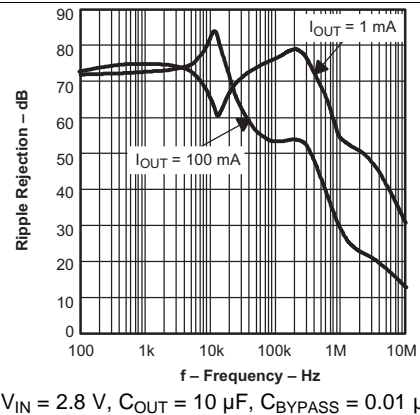
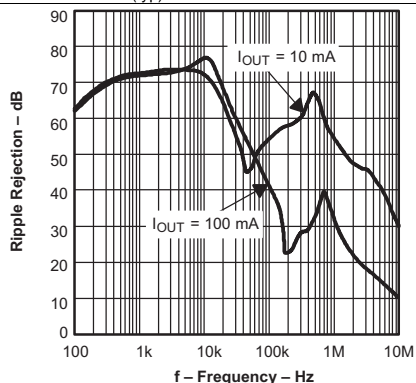

Figure 18. TPS79118 Ripple Rejection vs Frequency

Typical Characteristics (continued)

at $T_J = 25^\circ\text{C}$, $V_{IN} = V_{OUT(\text{typ})} + 1\text{ V}$, $I_{OUT} = 1\text{ mA}$, $EN = 0\text{ V}$, $C_{OUT} = 10\text{ }\mu\text{F}$, and $C_{BYPASS} = 0.01\text{ }\mu\text{F}$ (unless otherwise noted)



$V_{IN} = 2.8\text{ V}$, $C_{OUT} = 1\text{ }\mu\text{F}$, $C_{BYPASS} = 0.01\text{ }\mu\text{F}$

Figure 19. TPS79118 Ripple Rejection vs Frequency

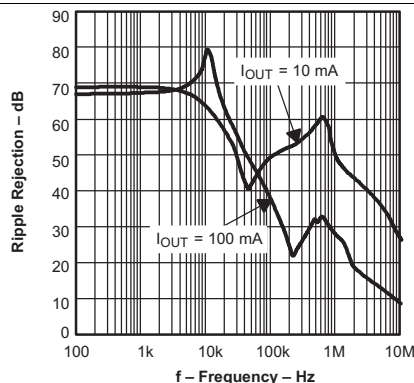

$V_{IN} = 2.8\text{ V}$, $C_{OUT} = 1\text{ }\mu\text{F}$, $C_{BYPASS} = 0.1\text{ }\mu\text{F}$

Figure 20. TPS79118 Ripple Rejection vs Frequency

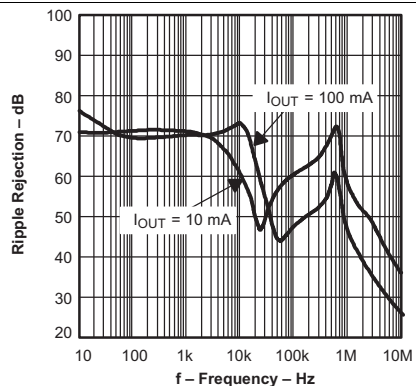

$V_{IN} = 4.3\text{ V}$, $C_{OUT} = 10\text{ }\mu\text{F}$, $C_{BYPASS} = 0.01\text{ }\mu\text{F}$

Figure 21. TPS79133 Ripple Rejection vs Frequency

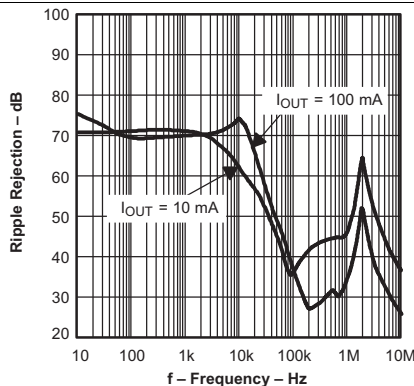

$V_{IN} = 4.3\text{ V}$, $C_{OUT} = 1\text{ }\mu\text{F}$, $C_{BYPASS} = 0.01\text{ }\mu\text{F}$

Figure 22. TPS79133 Ripple Rejection vs Frequency

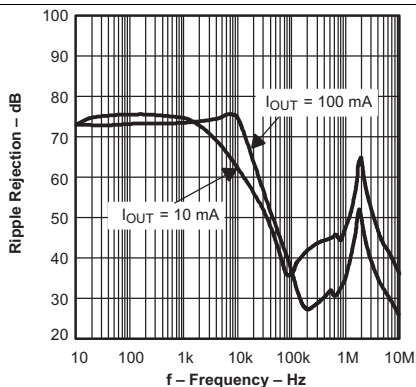

$V_{IN} = 4.3\text{ V}$, $C_{OUT} = 1\text{ }\mu\text{F}$, $C_{BYPASS} = 0.1\text{ }\mu\text{F}$

Figure 23. TPS79133 Ripple Rejection vs Frequency

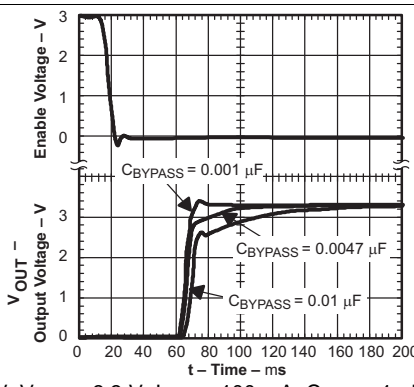

$V_{IN} = 4.3\text{ V}$, $V_{OUT} = 3.3\text{ V}$, $I_{OUT} = 100\text{ mA}$, $C_{OUT} = 1\text{ }\mu\text{F}$, $T_J = 25^\circ\text{C}$

Figure 24. TPS79133 Output Voltage, Enable Voltage vs Time (Start-Up)

Typical Characteristics (continued)

at $T_J = 25^\circ\text{C}$, $V_{IN} = V_{OUT(\text{typ})} + 1\text{ V}$, $I_{OUT} = 1\text{ mA}$, $EN = 0\text{ V}$, $C_{OUT} = 10\text{ }\mu\text{F}$, and $C_{BYPASS} = 0.01\text{ }\mu\text{F}$ (unless otherwise noted)

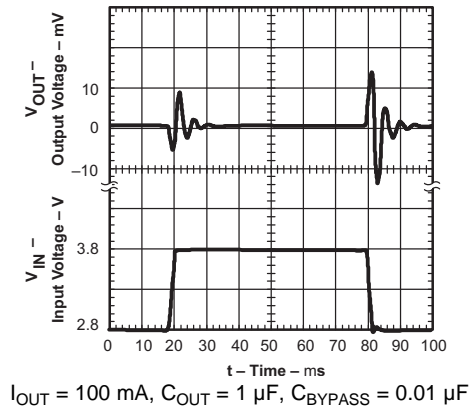

Figure 25. TPS79118 Line Transient Response

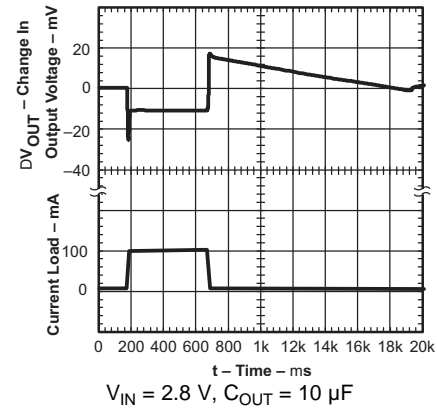

Figure 26. TPS79118 Load Transit Response

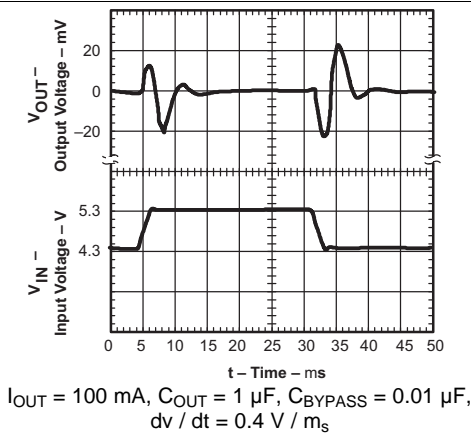

Figure 27. TPS79133 Line Transient Response

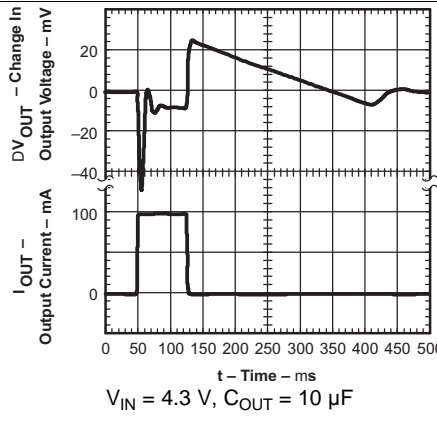

Figure 28. TPS79133 Load Transit Response

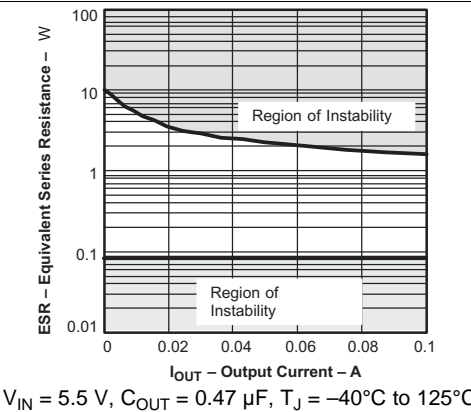

Figure 29. TPS79118 Typical Regions of Stability Equivalent Series Resistance (ESR) vs Output Current

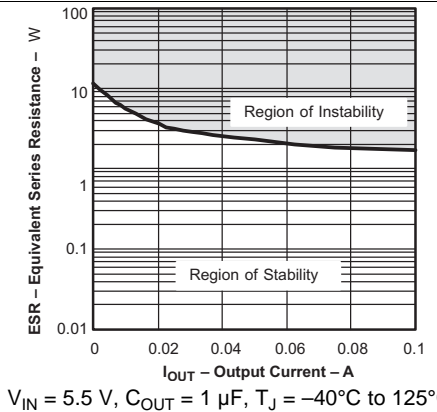

Figure 30. TPS79118 Typical Regions of Stability Equivalent Series Resistance (ESR) vs Output Current

Typical Characteristics (continued)

at $T_J = 25^\circ\text{C}$, $V_{IN} = V_{OUT(\text{typ})} + 1\text{ V}$, $I_{OUT} = 1\text{ mA}$, $EN = 0\text{ V}$, $C_{OUT} = 10\ \mu\text{F}$, and $C_{BYPASS} = 0.01\ \mu\text{F}$ (unless otherwise noted)

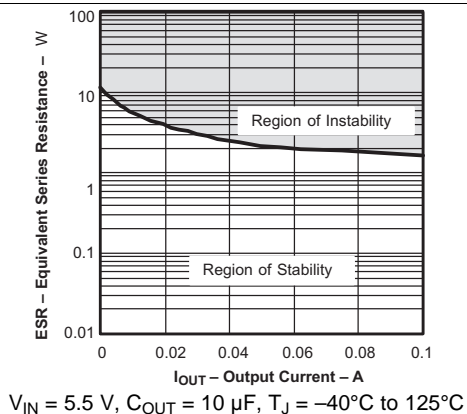

Figure 31. TPS79118 Typical Regions of Stability Equivalent Series Resistance (ESR) vs Output Current

7 Detailed Description

7.1 Overview

The TPS791 device is a high PSRR, ultra-low noise, 100-mA linear regulator (LDO). The fast start-up time and the excellent load and line transient behavior of this device qualify the TPS791 to be an ideal solution for signal RF and signal-chain applications.

7.2 Functional Block Diagrams

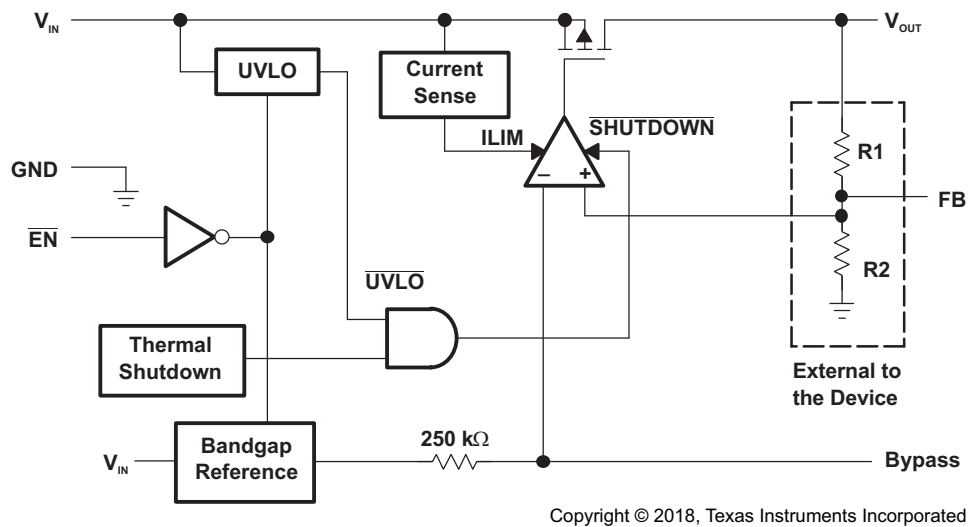

Figure 32. Functional Block Diagram: Adjustable Version

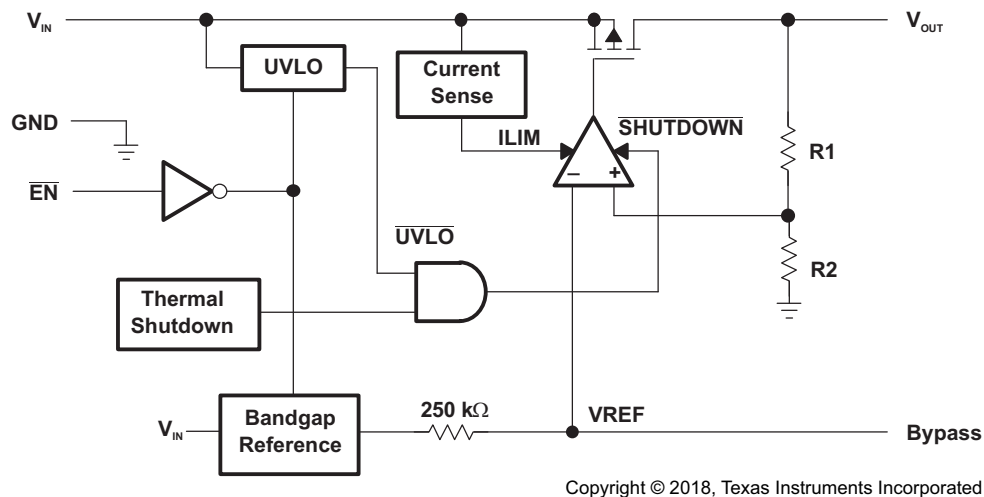

Figure 33. Functional Block Diagram: Fixed Version

7.3 Feature Description

7.3.1 Power Dissipation and Junction Temperature

Specified regulator operation is confirmed at a junction temperature of 125°C; restrict the maximum junction temperature to 125°C under normal operating conditions. This restriction limits the power dissipation the regulator can handle in any given application. To ensure the junction temperature is within acceptable limits, calculate the maximum allowable dissipation, $P_{D(max)}$, and the actual dissipation, P_D , which must be less than or equal to $P_{D(max)}$.

The maximum-power-dissipation limit is determined using the following equation:

$$P_{D(max)} = \frac{T_{Jmax} - T_A}{R_{\theta JA}}$$

where

- T_{Jmax} is the maximum allowable junction temperature
 - $R_{\theta JA}$ is the thermal resistance junction-to-ambient for the package (see the [Thermal Information](#) table)
 - T_A is the ambient temperature
- (1)

The regulator dissipation is calculated using:

$$P_D = (V_{IN} - V_{OUT}) \times I_{OUT}$$
(2)

Power dissipation resulting from quiescent current is negligible. Excessive power dissipation triggers the thermal protection circuit.

7.3.2 Programming the TPS79101 Adjustable Regulator

The output voltage of the TPS79101 adjustable regulator is programmed using an external resistor divider; see [Figure 32](#). The output voltage is calculated using:

$$V_{OUT} = V_{REF} \times \left(1 + \frac{R1}{R2} \right)$$

where

- $V_{REF} = 1.2246$ V typ (the internal reference voltage)
- (3)

Select resistors R1 and R2 for approximately a 50- μ A divider current. Lower value resistors can be used for improved noise performance, but the solution consumes more power. Avoid higher resistor values because leakage current into or out of FB across R1, R2 creates an offset voltage that artificially increases or decreases the feedback voltage and thus erroneously decreases or increases V_{OUT} . The recommended design procedure is to choose $R2 = 30.1$ k Ω to set the divider current at 50 μ A, $C1 = 15$ pF for stability, and then calculate R1 using:

$$R1 = \left(\frac{V_{OUT}}{V_{REF}} - 1 \right) \times R2$$
(4)

In order to improve the stability of the adjustable version, a small compensation capacitor is suggested to be placed between OUT and FB. For voltages < 1.8 V, the value of this capacitor must be 100 pF. For voltages > 1.8 V, the approximate value of this capacitor can be calculated as:

$$C1 = \frac{(3 \times 10^{-7}) \times (R1 + R2)}{(R1 \times R2)}$$
(5)

Feature Description (continued)

The table in [Figure 34](#) shows the suggested value of this capacitor for several resistor ratios. If this capacitor is not used (such as in a unity-gain configuration) or if an output voltage < 1.8 V is chosen, then the minimum recommended output capacitor is 2.2 μF instead of 1 μF .

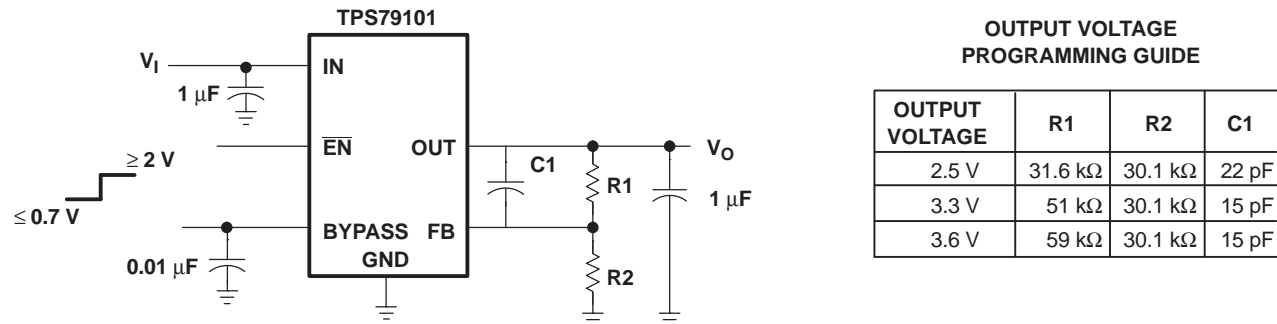

Figure 34. TPS79101 Adjustable LDO Regulator Programming

7.3.3 Regulator Protection

The TPS791 PMOS-pass transistor has a built-in back diode that conducts reverse current when the input voltage drops below the output voltage (for example, during power-down). Current is conducted from the output to the input and is not internally limited. If extended reverse voltage operation is anticipated, external limiting may be appropriate.

The TPS791 features internal current limiting and thermal protection. During normal operation, the TPS791 limits output current to approximately 400 mA. When current limiting engages, the output voltage scales back linearly until the overcurrent condition ends. Although current limiting is designed to prevent gross device failure, care must be taken not to exceed the power dissipation ratings of the package or the absolute maximum voltage ratings of the device. If the temperature of the device exceeds approximately 165°C, thermal-protection circuitry shuts the device down. When the device cools down to below approximately 140°C, regulator operation resumes.

7.4 Device Functional Modes

7.4.1 Normal Operation

The device regulates to the nominal output voltage under the following conditions:

- The input voltage is at least as high as the $|V_{IN(min)}|$
- The input voltage magnitude is greater than the nominal output voltage magnitude added to the dropout voltage
- $|V_{EN}| < \text{low-level enable pin input voltage (0.7 V)}$
- The output current is less than the current limit
- The device junction temperature is less than the maximum specified junction temperature

7.4.2 Dropout Operation

If the input voltage magnitude is lower than the nominal output voltage magnitude plus the specified dropout voltage magnitude, but all other conditions are met for normal operation, the device operates in dropout mode. In this mode of operation, the output voltage magnitude is the same as the input voltage magnitude minus the dropout voltage magnitude. The transient performance of the device is significantly degraded because the pass device (such as a bipolar junction transistor, or BJT) is in saturation and no longer controls the current through the LDO. Line or load transients in dropout can result in large output voltage deviations.

7.4.3 Disabled

The device is disabled under the following conditions:

- $|V_{EN}| > \text{high-level enable pin input voltage (2 V)}$
- The device junction temperature is greater than the thermal shutdown temperature

[Table 1](#) shows the conditions that lead to the different modes of operation.

Table 1. Device Functional Mode Comparison

OPERATING MODE	PARAMETER			
	V_{IN}	V_{EN}	I_{OUT}	T_J
Normal mode	$ V_{IN} > \{ V_{OUT(nom)} + V_{DO} , V_{IN(min)} \}$	$ V_{EN} < 0.7 \text{ V}$	$I_{OUT} < I_{CL}$	$T_J < 125^\circ\text{C}$
Dropout mode	$ V_{IN(min)} < V_{IN} < V_{OUT(nom)} + V_{DO} $	$ V_{EN} < 0.7 \text{ V}$	—	$T_J < 125^\circ\text{C}$
Disabled mode (any true condition disables the device)	—	$ V_{EN} > 2 \text{ V}$	—	$T_J > 170^\circ\text{C}$

8 Application and Implementation

NOTE

Information in the following applications sections is not part of the TI component specification, and TI does not warrant its accuracy or completeness. TI's customers are responsible for determining suitability of components for their purposes. Customers should validate and test their design implementation to confirm system functionality.

8.1 Application Information

The TPS791 low-dropout (LDO) regulator is optimized for use in noise-sensitive battery-operated equipment. The device features extremely low dropout voltages, high PSRR, ultralow output noise, low quiescent current (170 μA typically), and an active-low, enable input to reduce supply currents to less than 1 μA when the regulator is turned off.

8.1.1 External Capacitor Requirements

A 0.1- μF or larger ceramic input bypass capacitor, connected between IN and GND and located close to the TPS791, is required for stability and to improve transient response, noise rejection, and ripple rejection. A higher-value electrolytic input capacitor may be necessary if large, fast-rise-time load transients are anticipated and the device is located several inches from the power source.

Like all low dropout regulators, the TPS791 requires an output capacitor connected between OUT and GND to stabilize the internal control loop. The minimum recommended capacitance is 1 μF . Any 1- μF or larger ceramic capacitor is suitable. The device is also stable with a 0.47- μF ceramic capacitor with at least 75 m Ω of ESR.

The internal voltage reference is a key source of noise in an LDO regulator. The TPS791 has a BYPASS pin that is connected to the voltage reference through a 250-k Ω internal resistor. The 250-k Ω internal resistor, in conjunction with an external bypass capacitor connected to the BYPASS pin, creates a low-pass filter to reduce the voltage reference noise and, therefore, the noise at the regulator output. In order for the regulator to operate properly, the current flow out of the BYPASS pin must be at a minimum because any leakage current creates an IR drop across the internal resistor thus creating an output error. Therefore, the bypass capacitor must have minimal leakage current.

For example, the TPS79118 exhibits approximately 15 μV_{RMS} of output voltage noise using a 0.1- μF ceramic bypass capacitor and a 1- μF ceramic output capacitor. The output starts up slower as the bypass capacitance increases because of the RC time constant at the bypass pin that is created by the internal 250-k Ω resistor and external capacitor.

8.2 Typical Application

Figure 35 shows a typical application circuit.

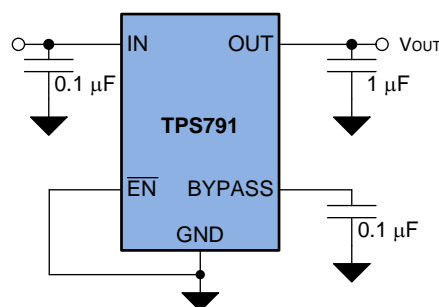

Copyright © 2018, Texas Instruments Incorporated

Figure 35. Typical Application Circuit

Typical Application (continued)

8.2.1 Design Requirements

Table 2 shows the parameters used for this design example.

Table 2. Design Parameters

PARAMETER	DESIGN REQUIREMENT
Input voltage	4.3 V to 3.5 V (Lithium Ion battery)
Output voltage	3.3 V
DC output current	10 mA
Peak output current	100 mA
Maximum ambient temperature	60°C

8.2.2 Detailed Design Procedure

Select the desired output voltage option. An input capacitor of 0.1 μF is used because the battery is connected to the input through a via and a short 10-mil (0.01-in) trace. An output capacitor of 1 mF is used in this design example. A smaller size output capacitor can be used up to a minimum of 1 μF to stabilize the internal control loop.

8.2.3 Application Curves

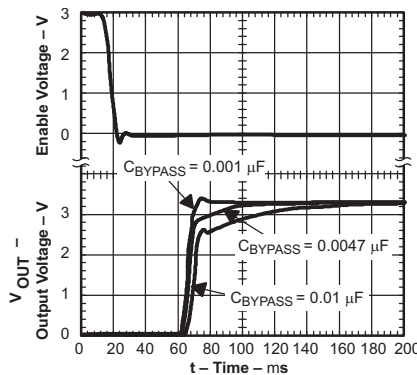
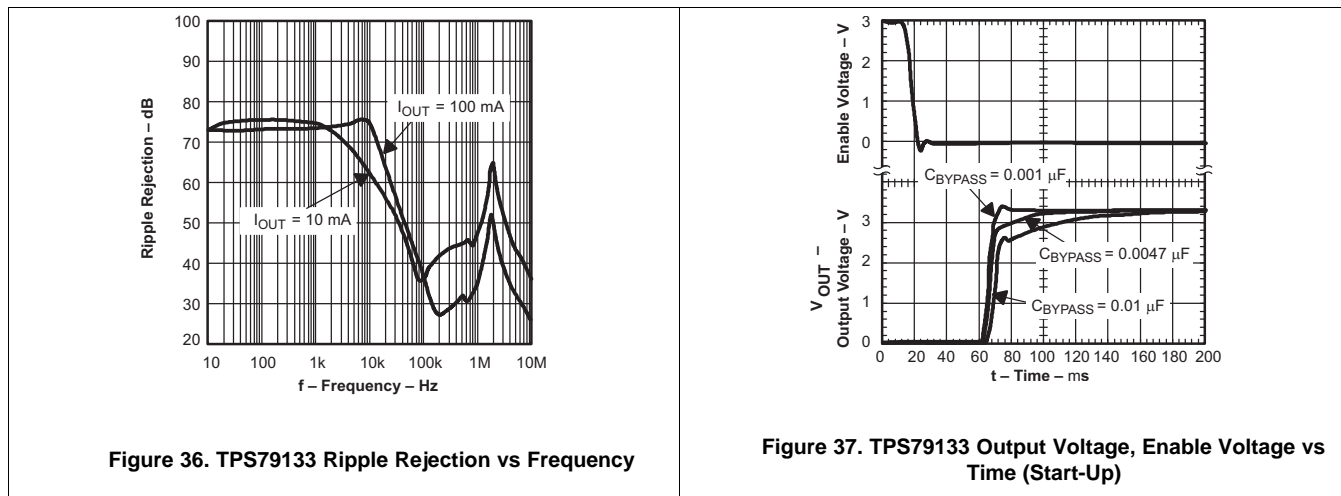

8.3 Do's and Don'ts

Do place at least one, low-ESR, 1- μF capacitor as close as possible between the OUT pin of the regulator and the GND pin.

Do place at least one, low-ESR, 0.1- μF capacitor as close as possible between the IN pin of the regulator and the GND pin.

Do provide adequate thermal paths away from the device.

Do not place the input or output capacitor more than 10 mm away from the regulator.

Do not exceed the absolute maximum ratings.

Do not float the Enable (EN) pin.

Do not resistively or inductively load the BYPASS pin.

Do not let the output voltage get more than 0.3 V above the input voltage.

9 Power Supply Recommendations

This device is designed to operate from an input voltage supply range from 2.7 V to 5.5 V. The input voltage range must provide adequate headroom in order for the device to have a regulated output. This input supply must be well-regulated and stable. A 0.1- μF input capacitor is required for stability; if the input supply is noisy, additional input capacitors with low ESR can help improve the output noise performance.

10 Layout

10.1 Layout Guidelines

Layout is a critical part of good power-supply design. There are several signal paths that conduct fast-changing currents or voltages that can interact with stray inductance or parasitic capacitance to generate noise or degrade the power-supply performance. To help eliminate these problems, bypass the IN pin to ground with a low ESR ceramic bypass capacitor with an X5R or X7R dielectric.

Equivalent series inductance (ESL) and equivalent series resistance (ESR) must be minimized to maximize performance and ensure stability. Every capacitor (C_{IN} , C_{OUT} , C_{BYPASS} , and C_1) must be placed as close as possible to the device and on the same side of the PCB as the regulator itself.

Do not place any capacitors on the opposite side of the PCB from where the regulator is installed. The use of vias and long traces is strongly discouraged because these circuits can impact system performance negatively, and even cause instability.

10.1.1 Board Layout Recommendation to Improve PSRR and Noise Performance

To improve ac measurements such as PSRR, output noise, and transient response, TI recommends that the board be designed with separate ground planes for V_{IN} and V_{OUT} , with each ground plane connected only at the ground pin of the device. In addition, connect the ground connection for the bypass capacitor directly to the ground pin of the device.

10.2 Layout Example

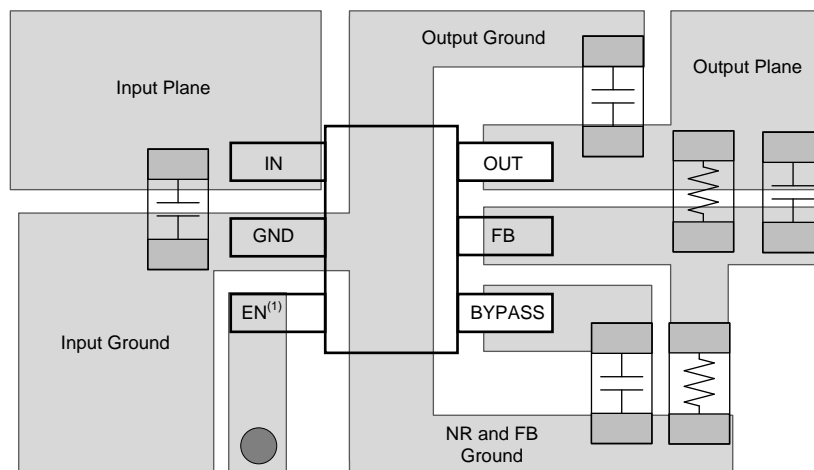

 Denotes via

(1) The EN pin is active low.

Figure 38. Layout Example (6-Pin DBV Package)

11 Device and Documentation Support

11.1 Receiving Notification of Documentation Updates

To receive notification of documentation updates, navigate to the device product folder on ti.com. In the upper right corner, click on *Alert me* to register and receive a weekly digest of any product information that has changed. For change details, review the revision history included in any revised document.

11.2 Community Resources

The following links connect to TI community resources. Linked contents are provided "AS IS" by the respective contributors. They do not constitute TI specifications and do not necessarily reflect TI's views; see TI's [Terms of Use](#).

TI E2E™ Online Community *TI's Engineer-to-Engineer (E2E) Community*. Created to foster collaboration among engineers. At e2e.ti.com, you can ask questions, share knowledge, explore ideas and help solve problems with fellow engineers.

Design Support *TI's Design Support* Quickly find helpful E2E forums along with design support tools and contact information for technical support.

11.3 Trademarks

E2E is a trademark of Texas Instruments.
All other trademarks are the property of their respective owners.

11.4 Electrostatic Discharge Caution



This integrated circuit can be damaged by ESD. Texas Instruments recommends that all integrated circuits be handled with appropriate precautions. Failure to observe proper handling and installation procedures can cause damage.

ESD damage can range from subtle performance degradation to complete device failure. Precision integrated circuits may be more susceptible to damage because very small parametric changes could cause the device not to meet its published specifications.

11.5 Glossary

[SLYZ022](#) — *TI Glossary*.

This glossary lists and explains terms, acronyms, and definitions.

12 Mechanical, Packaging, and Orderable Information

The following pages include mechanical, packaging, and orderable information. This information is the most current data available for the designated devices. This data is subject to change without notice and revision of this document. For browser-based versions of this data sheet, refer to the left-hand navigation.

PACKAGING INFORMATION

Orderable part number	Status (1)	Material type (2)	Package Pins	Package qty Carrier	RoHS (3)	Lead finish/ Ball material (4)	MSL rating/ Peak reflow (5)	Op temp (°C)	Part marking (6)
TPS79101DBVR	Active	Production	SOT-23 (DBV) 6	3000 LARGE T&R	Yes	NIPDAU	Level-1-260C-UNLIM	-40 to 125	PEUI
TPS79101DBVR.A	Active	Production	SOT-23 (DBV) 6	3000 LARGE T&R	Yes	NIPDAU	Level-1-260C-UNLIM	-40 to 125	PEUI
TPS79101DBVRG4	Active	Production	SOT-23 (DBV) 6	3000 LARGE T&R	Yes	NIPDAU	Level-1-260C-UNLIM	-40 to 125	PEUI
TPS79101DBVT	Obsolete	Production	SOT-23 (DBV) 6	-	-	Call TI	Call TI	-40 to 125	PEUI
TPS79118DBVR	Active	Production	SOT-23 (DBV) 5	3000 LARGE T&R	Yes	NIPDAU	Level-1-260C-UNLIM	-40 to 125	PERI
TPS79118DBVR.A	Active	Production	SOT-23 (DBV) 5	3000 LARGE T&R	Yes	NIPDAU	Level-1-260C-UNLIM	-40 to 125	PERI
TPS79118DBVT	Obsolete	Production	SOT-23 (DBV) 5	-	-	Call TI	Call TI	-40 to 125	PERI
TPS79133DBVR	Active	Production	SOT-23 (DBV) 5	3000 LARGE T&R	Yes	NIPDAU	Level-1-260C-UNLIM	-40 to 125	PESI
TPS79133DBVR.A	Active	Production	SOT-23 (DBV) 5	3000 LARGE T&R	Yes	NIPDAU	Level-1-260C-UNLIM	-40 to 125	PESI
TPS79133DBVRG4	Active	Production	SOT-23 (DBV) 5	3000 LARGE T&R	Yes	NIPDAU	Level-1-260C-UNLIM	-40 to 125	PESI
TPS79133DBVT	Obsolete	Production	SOT-23 (DBV) 5	-	-	Call TI	Call TI	-40 to 125	PESI
TPS79147DBVR	Active	Production	SOT-23 (DBV) 5	3000 LARGE T&R	Yes	NIPDAU	Level-1-260C-UNLIM	-40 to 125	PETI
TPS79147DBVR.A	Active	Production	SOT-23 (DBV) 5	3000 LARGE T&R	Yes	NIPDAU	Level-1-260C-UNLIM	-40 to 125	PETI
TPS79147DBVT	Obsolete	Production	SOT-23 (DBV) 5	-	-	Call TI	Call TI	-40 to 125	PETI

(1) **Status:** For more details on status, see our [product life cycle](#).

(2) **Material type:** When designated, preproduction parts are prototypes/experimental devices, and are not yet approved or released for full production. Testing and final process, including without limitation quality assurance, reliability performance testing, and/or process qualification, may not yet be complete, and this item is subject to further changes or possible discontinuation. If available for ordering, purchases will be subject to an additional waiver at checkout, and are intended for early internal evaluation purposes only. These items are sold without warranties of any kind.

(3) **RoHS values:** Yes, No, RoHS Exempt. See the [TI RoHS Statement](#) for additional information and value definition.

(4) **Lead finish/Ball material:** Parts may have multiple material finish options. Finish options are separated by a vertical ruled line. Lead finish/Ball material values may wrap to two lines if the finish value exceeds the maximum column width.

(5) **MSL rating/Peak reflow:** The moisture sensitivity level ratings and peak solder (reflow) temperatures. In the event that a part has multiple moisture sensitivity ratings, only the lowest level per JEDEC standards is shown. Refer to the shipping label for the actual reflow temperature that will be used to mount the part to the printed circuit board.

(6) **Part marking:** There may be an additional marking, which relates to the logo, the lot trace code information, or the environmental category of the part.

Multiple part markings will be inside parentheses. Only one part marking contained in parentheses and separated by a "~" will appear on a part. If a line is indented then it is a continuation of the previous line and the two combined represent the entire part marking for that device.

Important Information and Disclaimer: The information provided on this page represents TI's knowledge and belief as of the date that it is provided. TI bases its knowledge and belief on information provided by third parties, and makes no representation or warranty as to the accuracy of such information. Efforts are underway to better integrate information from third parties. TI has taken and continues to take reasonable steps to provide representative and accurate information but may not have conducted destructive testing or chemical analysis on incoming materials and chemicals. TI and TI suppliers consider certain information to be proprietary, and thus CAS numbers and other limited information may not be available for release.

In no event shall TI's liability arising out of such information exceed the total purchase price of the TI part(s) at issue in this document sold by TI to Customer on an annual basis.

OTHER QUALIFIED VERSIONS OF TPS791 :

- Automotive : [TPS791-Q1](#)

NOTE: Qualified Version Definitions:

- Automotive - Q100 devices qualified for high-reliability automotive applications targeting zero defects

TAPE AND REEL INFORMATION

QUADRANT ASSIGNMENTS FOR PIN 1 ORIENTATION IN TAPE

*All dimensions are nominal

Device	Package Type	Package Drawing	Pins	SPQ	Reel Diameter (mm)	Reel Width W1 (mm)	A0 (mm)	B0 (mm)	K0 (mm)	P1 (mm)	W (mm)	Pin1 Quadrant
TPS79101DBVR	SOT-23	DBV	6	3000	178.0	9.0	3.23	3.17	1.37	4.0	8.0	Q3
TPS79118DBVR	SOT-23	DBV	5	3000	178.0	9.0	3.23	3.17	1.37	4.0	8.0	Q3
TPS79133DBVR	SOT-23	DBV	5	3000	178.0	9.0	3.23	3.17	1.37	4.0	8.0	Q3
TPS79147DBVR	SOT-23	DBV	5	3000	178.0	9.0	3.3	3.2	1.4	4.0	8.0	Q3

TAPE AND REEL BOX DIMENSIONS

*All dimensions are nominal

Device	Package Type	Package Drawing	Pins	SPQ	Length (mm)	Width (mm)	Height (mm)
TPS79101DBVR	SOT-23	DBV	6	3000	180.0	180.0	18.0
TPS79118DBVR	SOT-23	DBV	5	3000	180.0	180.0	18.0
TPS79133DBVR	SOT-23	DBV	5	3000	180.0	180.0	18.0
TPS79147DBVR	SOT-23	DBV	5	3000	180.0	180.0	18.0

DBV0005A



PACKAGE OUTLINE

SOT-23 - 1.45 mm max height

SMALL OUTLINE TRANSISTOR

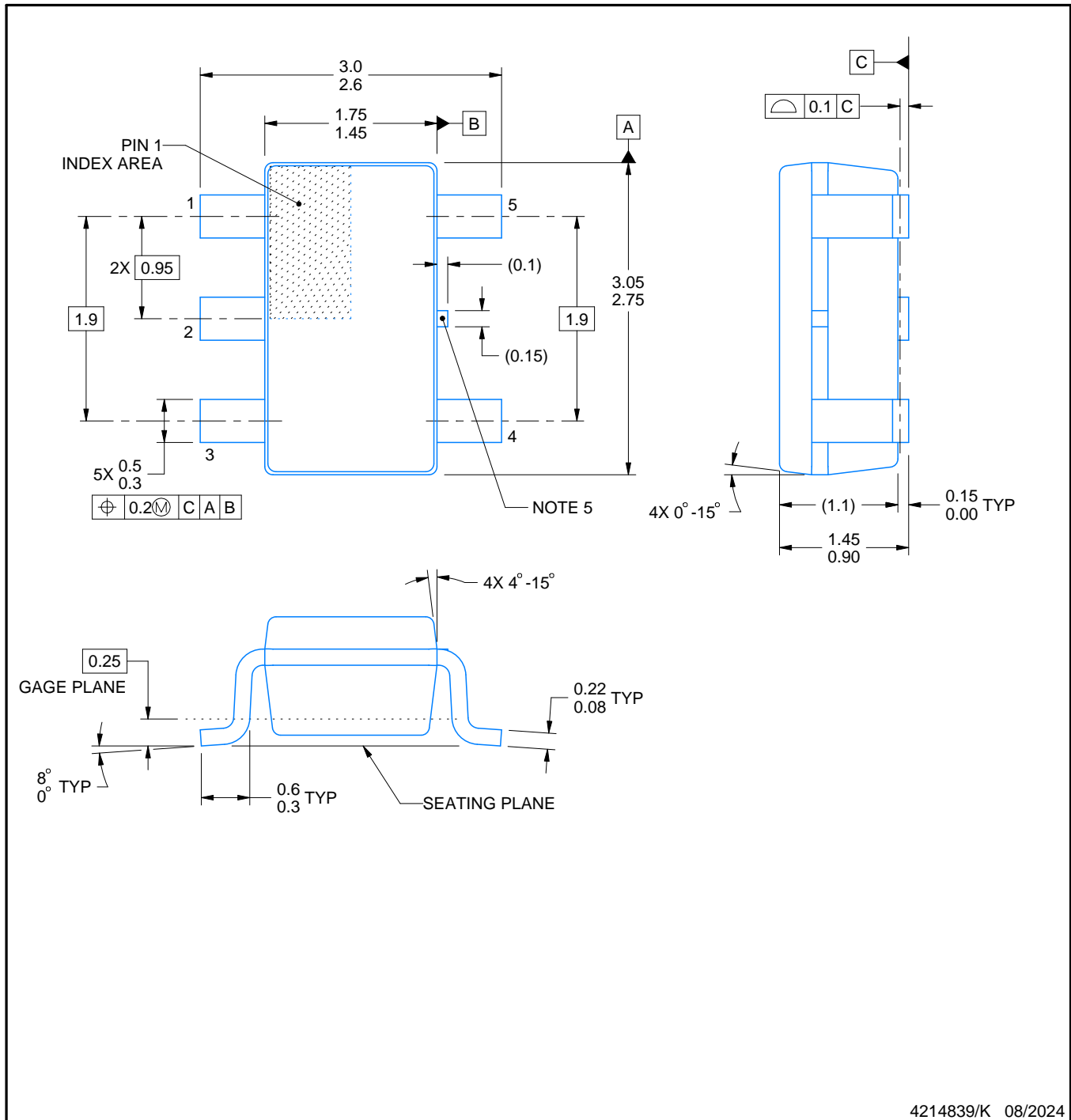

NOTES:

1. All linear dimensions are in millimeters. Any dimensions in parenthesis are for reference only. Dimensioning and tolerancing per ASME Y14.5M.
2. This drawing is subject to change without notice.
3. Reference JEDEC MO-178.
4. Body dimensions do not include mold flash, protrusions, or gate burrs. Mold flash, protrusions, or gate burrs shall not exceed 0.25 mm per side.
5. Support pin may differ or may not be present.

EXAMPLE BOARD LAYOUT

DBV0005A

SOT-23 - 1.45 mm max height

SMALL OUTLINE TRANSISTOR



LAND PATTERN EXAMPLE
EXPOSED METAL SHOWN
SCALE:15X



SOLDER MASK DETAILS

4214839/K 08/2024

NOTES: (continued)

- 6. Publication IPC-7351 may have alternate designs.
- 7. Solder mask tolerances between and around signal pads can vary based on board fabrication site.

EXAMPLE STENCIL DESIGN

DBV0005A

SOT-23 - 1.45 mm max height

SMALL OUTLINE TRANSISTOR



SOLDER PASTE EXAMPLE
BASED ON 0.125 mm THICK STENCIL
SCALE:15X

4214839/K 08/2024

NOTES: (continued)

8. Laser cutting apertures with trapezoidal walls and rounded corners may offer better paste release. IPC-7525 may have alternate design recommendations.
9. Board assembly site may have different recommendations for stencil design.



DBV0006A

PACKAGE OUTLINE

SOT-23 - 1.45 mm max height

SMALL OUTLINE TRANSISTOR

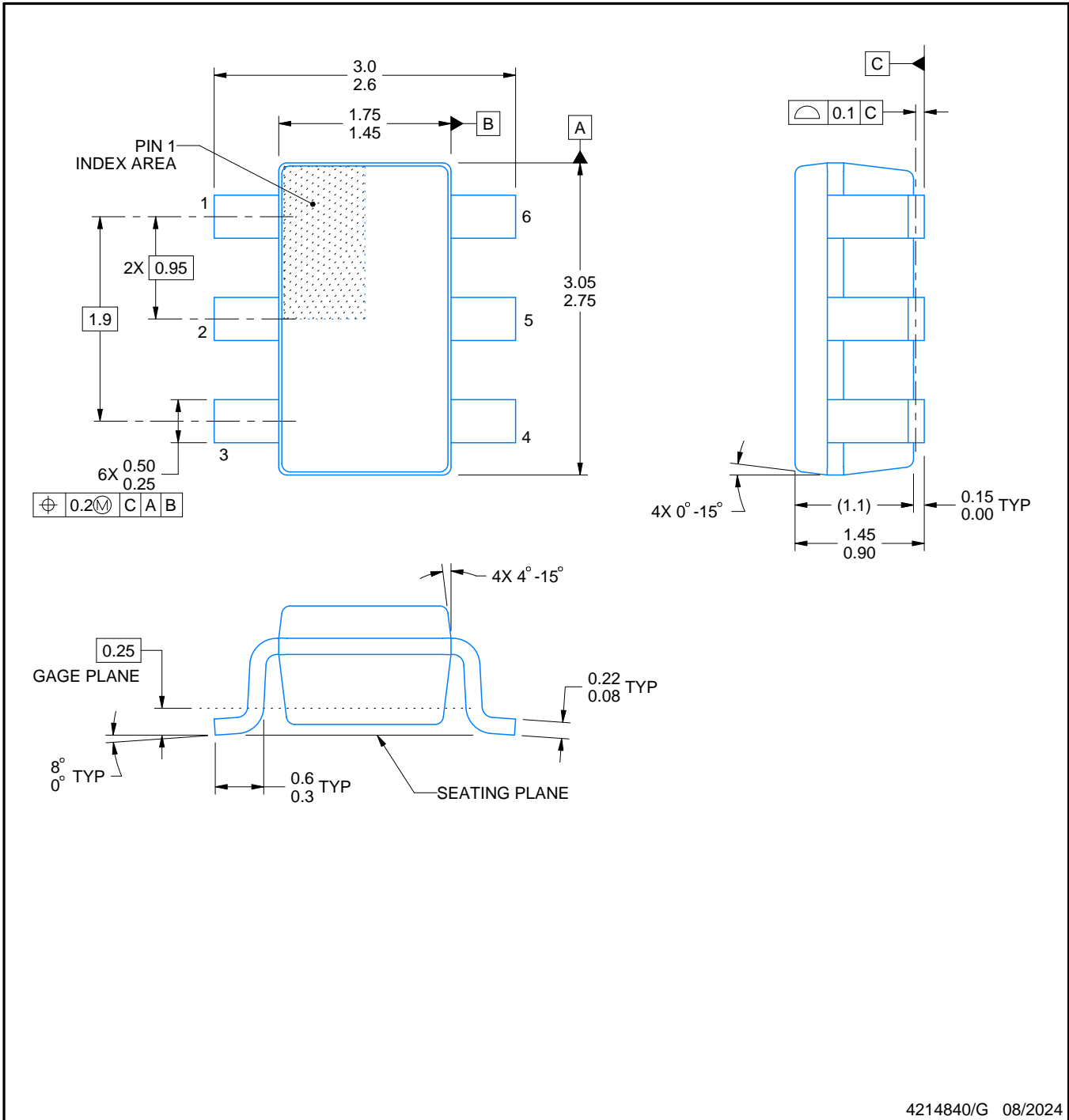

4214840/G 08/2024

NOTES:

1. All linear dimensions are in millimeters. Any dimensions in parenthesis are for reference only. Dimensioning and tolerancing per ASME Y14.5M.
2. This drawing is subject to change without notice.
3. Body dimensions do not include mold flash or protrusion. Mold flash and protrusion shall not exceed 0.25 per side.
4. Leads 1,2,3 may be wider than leads 4,5,6 for package orientation.
5. Reference JEDEC MO-178.

EXAMPLE BOARD LAYOUT

DBV0006A

SOT-23 - 1.45 mm max height

SMALL OUTLINE TRANSISTOR



LAND PATTERN EXAMPLE
EXPOSED METAL SHOWN
SCALE:15X



SOLDER MASK DETAILS

4214840/G 08/2024

NOTES: (continued)

- 6. Publication IPC-7351 may have alternate designs.
- 7. Solder mask tolerances between and around signal pads can vary based on board fabrication site.

EXAMPLE STENCIL DESIGN

DBV0006A

SOT-23 - 1.45 mm max height

SMALL OUTLINE TRANSISTOR



SOLDER PASTE EXAMPLE
BASED ON 0.125 mm THICK STENCIL
SCALE:15X

4214840/G 08/2024

NOTES: (continued)

8. Laser cutting apertures with trapezoidal walls and rounded corners may offer better paste release. IPC-7525 may have alternate design recommendations.
9. Board assembly site may have different recommendations for stencil design.

IMPORTANT NOTICE AND DISCLAIMER

TI PROVIDES TECHNICAL AND RELIABILITY DATA (INCLUDING DATASHEETS), DESIGN RESOURCES (INCLUDING REFERENCE DESIGNS), APPLICATION OR OTHER DESIGN ADVICE, WEB TOOLS, SAFETY INFORMATION, AND OTHER RESOURCES "AS IS" AND WITH ALL FAULTS, AND DISCLAIMS ALL WARRANTIES, EXPRESS AND IMPLIED, INCLUDING WITHOUT LIMITATION ANY IMPLIED WARRANTIES OF MERCHANTABILITY, FITNESS FOR A PARTICULAR PURPOSE OR NON-INFRINGEMENT OF THIRD PARTY INTELLECTUAL PROPERTY RIGHTS.

These resources are intended for skilled developers designing with TI products. You are solely responsible for (1) selecting the appropriate TI products for your application, (2) designing, validating and testing your application, and (3) ensuring your application meets applicable standards, and any other safety, security, regulatory or other requirements.

These resources are subject to change without notice. TI grants you permission to use these resources only for development of an application that uses the TI products described in the resource. Other reproduction and display of these resources is prohibited. No license is granted to any other TI intellectual property right or to any third party intellectual property right. TI disclaims responsibility for, and you fully indemnify TI and its representatives against any claims, damages, costs, losses, and liabilities arising out of your use of these resources.

TI's products are provided subject to [TI's Terms of Sale](#), [TI's General Quality Guidelines](#), or other applicable terms available either on ti.com or provided in conjunction with such TI products. TI's provision of these resources does not expand or otherwise alter TI's applicable warranties or warranty disclaimers for TI products. Unless TI explicitly designates a product as custom or customer-specified, TI products are standard, catalog, general purpose devices.

TI objects to and rejects any additional or different terms you may propose.

Copyright © 2025, Texas Instruments Incorporated

Last updated 10/2025