

TXS0104W-Q1 Automotive 4-Bit Bidirectional Voltage-Level Translator for Open-Drain and Push-Pull Applications

1 Features

- Qualified for automotive applications
- AEC-Q100 qualified with the following results:
 - Device temperature grade 1: -40°C to $+125^{\circ}\text{C}$ ambient operating temperature range
 - Device HBM ESD Classification Level 2
 - Device CDM ESD Classification Level C6
- No direction-control signal required
- Maximum data rates:
 - 50Mbps maximum (push pull)
 - 2Mbps (open drain)
- 1.2V to 3.6V on A port and 1.65V to 5.5V on B port
- V_{CCA} can be $>$, $=$, $<$ V_{CCB}
- No power-supply sequencing required— V_{CCA} or V_{CCB} can be ramped first
- ESD protection exceeds JESD 22:
 - A Port
 - 2000V Human-Body Model (A114-B)
 - 1000V Charged-Device Model (C101)
 - B Port
 - 8kV Human-Body Model (A114-B)
 - 1000V Charged-Device Model (C101)

2 Applications

- [Automotive infotainment, advance driver assistance systems \(ADAS\)](#)
- Isolates and level translates between main processor and peripheral modules
- I²C or 1-wire voltage-level translation

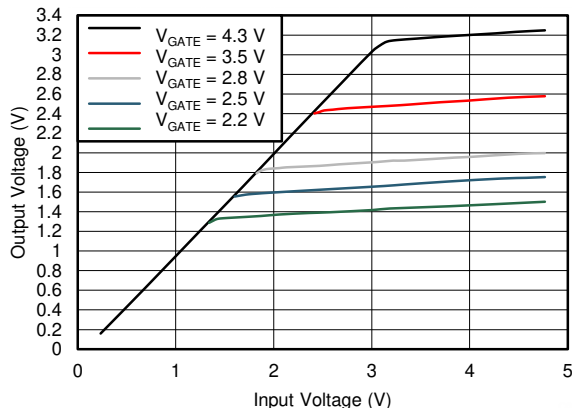

Transfer Characteristics of an N-Channel Transistor

3 Description

The TXS0104W-Q1 device connects an incompatible logic communication from chip-to-chip due to voltage mismatch. This auto-direction translator is used to bridge the gap without the need of direction control from the host. Each channel can be mixed and matched with different output types (open-drain or push-pull) and mixed data flows (transmit or receive) without intervention from the host. This 4-bit noninverting translator uses two separate configurable power-supply rails. The A and B ports are designed to track V_{CCA} and V_{CCB} respectively. The V_{CCB} pin accepts any supply voltage from 1.65V to 5.5V. The V_{CCA} pin accepts any supply voltage from 1.2V to 3.6V such that V_{CCA} is less than or equal to V_{CCB} . This tracking allows for low-voltage bidirectional translation between any of the 1.8V, 2.5V, 3.3V, and 5V voltage nodes.

When the output-enable (OE) input is low, all outputs are placed in the high-impedance state.

The TXS0104W-Q1 device is designed so that the OE input circuit is supplied by V_{CCA} .

To be in the high-impedance state during power up or power down, the OE pin must be tied to the GND pin through a pull down resistor. The minimum value of the resistor is determined by the current-sourcing capability of the driver.

Package Information

PART NUMBER	PACKAGE ⁽¹⁾	PACKAGE SIZE ⁽²⁾
TXS0104W-Q1	PW (TSSOP, 14)	5mm × 6.4mm
	BQA (WQFN, 14)	3mm × 2.5mm
	RUT (UQFN, 12)	2mm × 1.7mm

- (1) For all available packages, see the orderable addendum at the end of the data sheet.
- (2) The package size (length × width) is a nominal value and includes pins, where applicable.



Table of Contents

1 Features	1	7 Detailed Description	18
2 Applications	1	7.1 Overview.....	18
3 Description	1	7.2 Functional Block Diagram.....	18
4 Pin Configuration and Functions	3	7.3 Feature Description.....	19
5 Specifications	5	7.4 Device Functional Modes.....	19
5.1 Absolute Maximum Ratings.....	5	8 Application and Implementation	20
5.2 ESD Ratings.....	5	8.1 Application Information.....	20
5.3 Recommended Operating Conditions.....	6	8.2 Typical Application.....	20
5.4 Thermal Information.....	6	8.3 Power Supply Recommendations.....	21
5.5 Electrical Characteristics.....	7	8.4 Layout.....	22
5.6 Switching Characteristics, $V_{CCA} = 1.2V$	8	9 Device and Documentation Support	23
5.7 Switching Characteristics, $V_{CCA} = 1.5 \pm 0.1V$	9	9.1 Documentation Support.....	23
5.8 Switching Characteristics, $V_{CCA} = 1.8 \pm 0.15V$	10	9.2 Receiving Notification of Documentation Updates.....	23
5.9 Switching Characteristics, $V_{CCA} = 2.5 \pm 0.2V$	11	9.3 Support Resources.....	23
5.10 Switching Characteristics, $V_{CCA} = 3.3 \pm 0.3V$	12	9.4 Trademarks.....	23
5.11 Switching Characteristics: T_{sk}, T_{MAX}	13	10 Electrostatic Discharge Caution	23
5.12 Typical Characteristics.....	15	11 Glossary	23
6 Parameter Measurement Information	16	12 Revision History	23
6.1 Load Circuits.....	16	13 Mechanical, Packaging, and Orderable Information	23
6.2 Voltage Waveforms.....	17		

4 Pin Configuration and Functions

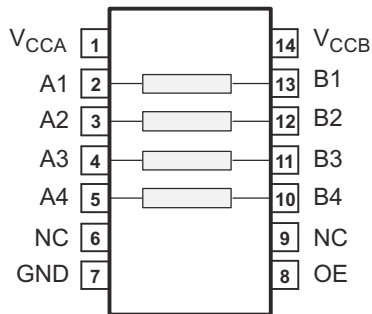

NC - No internal connection

Figure 4-1. PW Package, 14-Pin TSSOP (Top View)

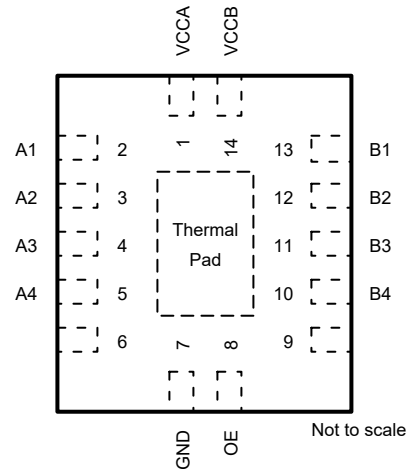

NC - No internal connection

Figure 4-2. BQA Package, 14-Pin WQFN (Top View)

Table 4-1. Pin Functions

PIN		TYPE ⁽¹⁾	DESCRIPTION
NAME	NO.		
A1	2	I/O	Input-output 1 for the A port. This pin is referenced to V_{CCA} .
A2	3	I/O	Input-output 2 for the A port. This pin is referenced to V_{CCA} .
A3	4	I/O	Input-output 3 for the A port. This pin is referenced to V_{CCA} .
A4	5	I/O	Input-output 4 for the A port. This pin is referenced to V_{CCA} .
B1	13	I/O	Input-output 1 for the B port. This pin is referenced to V_{CCB} .
B2	12	I/O	Input-output 2 for the B port. This pin is referenced to V_{CCB} .
B3	11	I/O	Input-output 3 for the B port. This pin is referenced to V_{CCB} .
B4	10	I/O	Input-output 4 for the B port. This pin is referenced to V_{CCB} .
GND	7	—	Ground
NC	6	—	No connection
	9		
OE	8	I	Tri-state output-mode enable. Pull the OE pin low to place all outputs in tri-state mode. This pin is referenced to V_{CCA} .
V_{CCA}	1	I	A-port supply voltage. $1.2V \leq V_{CCA} \leq 3.6V$ and V_{CCA} can be greater than, less than, or equal to V_{CCB} .
V_{CCB}	14	I	B-port supply voltage. $1.65V \leq V_{CCB} \leq 5.5V$.

(1) I = input, O = output

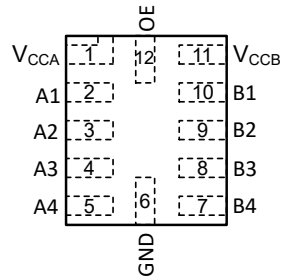

Figure 4-3. RUT Package, 12-Pin UQFN (Transparent Top View)

Table 4-2. Pin Functions: RUT

PIN		TYPE ⁽¹⁾	DESCRIPTION
NAME	NO.		
A1	2	I/O	Input/output A1. Referenced to V_{CCA} .
A2	3	I/O	Input/output A2. Referenced to V_{CCA} .
A3	4	I/O	Input/output A3. Referenced to V_{CCA} .
A4	5	I/O	Input/output A4. Referenced to V_{CCA} .
B1	10	I/O	Input/output B1. Referenced to V_{CCB} .
B2	9	I/O	Input/output B2. Referenced to V_{CCB} .
B3	8	I/O	Input/output B3. Referenced to V_{CCB} .
B4	7	I/O	Input/output B4. Referenced to V_{CCB} .
GND	6	—	Ground
OE	12	I	3-state output-mode enable. Pull OE low to place all outputs in 3-state mode. Referenced to V_{CCA} .
V_{CCA}	1	—	A-port supply voltage. $1.2V \leq V_{CCA} \leq 3.6V$ and V_{CCA} can be greater than, less than, or equal to V_{CCB} .
V_{CCB}	11	—	A-port supply voltage. $1.65V \leq V_{CCB} \leq 3.6V$

(1) I = input, O = output

5 Specifications

5.1 Absolute Maximum Ratings

over operating free-air temperature range (unless otherwise noted)⁽¹⁾

			MIN	MAX	UNIT
V _{CCA}	Supply voltage A		-0.5	4.6	V
V _{CCB}	Supply voltage B		-0.5	6.5	V
V _I	Input Voltage ⁽²⁾	I/O Ports (A Port)	-0.5	4.6	V
		I/O Ports (B Port)	-0.5	6.5	
		OE	-0.5	6.5	
V _O	Voltage applied to any output in the high-impedance or power-off state ⁽²⁾	A Port	-0.5	4.6	V
		B Port	-0.5	6.5	
V _O	Voltage applied to any output in the high or low state ^{(2) (3)}	A Port	-0.5	V _{CCA} + 0.5	V
		B Port	-0.5	V _{CCB} + 0.5	
I _{IK}	Input clamp current	V _I < 0	-50		mA
I _{OK}	Output clamp current	V _O < 0	-50		mA
I _O	Continuous output current		-50	50	mA
	Continuous current through V _{CC} or GND		-100	100	mA
T _j	Junction Temperature			150	°C
T _{stg}	Storage temperature		-65	150	°C

- (1) Stresses beyond those listed under [Section 5.1](#) may cause permanent damage to the device. These are stress ratings only, which do not imply functional operation of the device at these or any other conditions beyond those indicated under [Section 5.3](#) Exposure beyond the limits listed in [Section 5.3](#) may affect device reliability.
- (2) The input voltage and output negative-voltage ratings may be exceeded if the input and output current ratings are observed.
- (3) The output positive-voltage rating may be exceeded up to 6.5V maximum if the output current rating is observed.

5.2 ESD Ratings

			VALUE	UNIT	
V _(ESD)	Electrostatic discharge	Human body model (HBM), per AEC Q100-002	A Port	±2000	V
			B Port	±15000	
		Charged device model (CDM), per AEC Q100-011	A Port	±1000	
			B Port	±1000	

5.3 Recommended Operating Conditions

over operating free-air temperature range (unless otherwise noted)

			V _{CCA}	V _{CCB}	MIN	MAX	UNIT
V _{CCA}	Supply voltage A				1.2	3.6	V
V _{CCB}	Supply voltage B				1.65	5.5	V
V _{IH}	High-level input voltage	A-port I/O's	1.2V to 1.6V	1.65V to 5.5V	V _{CCA} - 0.2	V _{CCA}	V
			1.65V to 3.6V	2.3V to 5.5V	V _{CCA} - 0.4	V _{CCA}	
		B-port I/O's	1.2V to 3.6V	1.65V to 5.5V	V _{CCB} - 0.4	V _{CCB}	
		OE Input	1.2V to 3.6V	1.65V to 5.5V	V _{CCA} × 0.65	5.5	
V _{IL}	Low-level input voltage	A-port I/O's	1.2V to 3.6V	1.65V to 5.5V			0.2
		B-port I/O's	1.2V to 3.6V	1.65V to 5.5V			0.2
		OE Input	1.2V to 3.6V	1.65V to 5.5V			V _{CCA} × 0.35
V _{RTA}	RTA Activation Threshold	A-port I/O's	1.2V to 3.6V	1.65V to 5.5V	V _{CCI} × 0.30		V
		B-port I/O's	1.2V to 3.6V	1.65V to 5.5V	V _{CCI} × 0.30		
Δt/Δv	Input transition rise and fall time	Push-Pull Driving	1.2V to 3.6V	1.65V to 5.5V			10 ns/V
T _A	Operating free-air temperature				-40	125	°C

5.4 Thermal Information

THERMAL METRIC ⁽¹⁾		TXS0104W-Q1			UNIT
		BQA (WQFN)	RUT (UQFN)	PW (TSSOP)	
		14 PINS	12 PINS	14 PINS	
R _{θJA}	Junction-to-ambient thermal resistance	73.5	150.4	115.2	°C/W
R _{θJC(top)}	Junction-to-case (top) thermal resistance	76.9	68.6	46.2	°C/W
R _{θJB}	Junction-to-board thermal resistance	43.0	76.3	70.9	°C/W
Y _{JT}	Junction-to-top characterization parameter	4.7	2.4	3.4	°C/W
Y _{JB}	Junction-to-board characterization parameter	42.9	76.2	70.2	°C/W
R _{θJC(bottom)}	Junction-to-case (bottom) thermal resistance	19.6	N/A	N/A	°C/W

(1) For more information about traditional and new thermal metrics, see the [Semiconductor and IC Package Thermal Metrics](#) application note.

5.5 Electrical Characteristics

over operating free-air temperature range (unless otherwise noted)

PARAMETER	TEST CONDITIONS	V _{CCA}	V _{CCB}	Operating free-air temperature (T _A)									UNIT	
				25°C			-40°C to 85°C			-40°C to 125°C				
				MIN	TYP	MAX	MIN	TYP	MAX	MIN	TYP	MAX		
V _{OHA}	Port A output high voltage (2)	I _{OH} = -20 μA V _{I(Bx)} ≥ V _{CCB} - 0.4 V	1.2 V to 3.6 V	1.65 V to 5.5 V	V _{CCA} x 0.8			V _{CCA} x 0.8			V _{CCA} x 0.8			V
			1.65 V to 3.6 V	1.65 V to 5.5 V	V _{CCA} x 0.8			V _{CCA} x 0.8			V _{CCA} x 0.8			
V _{OHB}	Port B output high voltage	I _{OH} = -20 μA V _{I(Ax)} ≥ V _{CCA} - 0.4 V	1.2 V to 3.6 V	1.65 V to 5.5 V	V _{CCB} x 0.8			V _{CCB} x 0.8			V _{CCB} x 0.8			V
			1.65 V to 3.6 V	1.65 V to 5.5 V	V _{CCB} x 0.8			V _{CCB} x 0.8			V _{CCB} x 0.8			
V _{OLA}	Low-level output voltage (3)	I _{OL} = 1 mA V _{I(Bx)} ≤ 0.15 V	1.2 V to 3.6 V	1.65 V to 5.5 V			0.4			0.4		0.4	V	
V _{OLB}	Low-level output voltage (3)	I _{OL} = 1 mA V _{I(Ax)} ≤ 0.15 V	1.2 V to 3.6 V	1.65 V to 5.5 V			0.4			0.4		0.4	V	
I _I	Input leakage current	OE V _I = V _{CC} or GND	1.2 V to 3.6 V	1.65 V to 5.5 V	-2	2		-2	2		-2	2	μA	
I _{OZ}	Tri-state output current	A or B Port: V _I = V _{CCI} or GND V _O = V _{CCO} or GND OE = GND	1.2 V to 3.6 V	1.65 V to 5.5 V	-1	1		-2	2		-3	3	μA	
I _{CCA}	V _{CCA} supply current	V _I = V _{CCI} or GND I _O = 0	1.2 V to 3.6 V	1.65 V to 5.5 V			2.4			3.3		6.2	μA	
			0 V	5.5 V	-3			-3		-3				
			3.6 V	0 V			2.2		2.2		2.2			
I _{CCB}	V _{CCB} supply current	V _I = V _{CCI} or GND I _O = 0	1.2 V to 3.6 V	1.65 V to 5.5 V			12			12		21	μA	
			0 V	5.5 V			5		5		8			
			3.6 V	0 V	-1		-1		-1		-1			
I _{CCA} + I _{CCB}	Combined supply current	V _I = V _{CCI} or GND I _O = 0	1.2 V to 3.6 V	1.65 V to 5.5 V			14.4			14.4		25	μA	
C _i	Control Input Capacitance	V _I = 3.3 V or GND	3.3 V	3.3 V			6			6		6	pF	
C _{io}	Data I/O Capacitance	OE = GND, V _O = 1.65V DC +1 MHz -16 dBm sine wave	3.3 V	3.3 V			5	6.5		12	16.5	12	16.5	pF

(1) V_{CCI} is the V_{CC} associated with the input port

(2) Tested at V_I = V_{T+(MAX)}

(3) Tested at V_I = V_{T-(MIN)}

5.6 Switching Characteristics, $V_{CCA} = 1.2V$

PARAMETER		FROM	TO	TEST CONDITIONS	B-Port Supply Voltage (V_{CCB})								UNIT
					1.8 ± 0.15V		2.5 ± 0.2V		3.3 ± 0.3V		5.0 ± 0.5V		
					MIN	MAX	MIN	MAX	MIN	MAX	MIN	MAX	
t_{PHL}	Propagation Delay (Hight-to-Low)	A	B	Push-Pull	6.7		7.3		8.3		9.8		ns
				Open-Drain	7.2		8.4		10		12.7		
t_{PLH}	Propagation Delay (Low-to-High)			Push-Pull	16		13.8		15.3		29.5		
				Open-Drain	58.7		53.1		49		55.2		
t_{PHL}	Propagation Delay (Hight-to-Low)	B	A	Push-Pull	3.9		3.9		4.3		5.5		ns
				Open-Drain	4.1		4.3		4.9		6.2		
t_{PLH}	Propagation Delay (Low-to-High)			Push-Pull	1.4		0.6		0.2		0.5		
				Open-Drain	0.6		0.5		0.5		0.5		
t_{en}	Enable Time	OE	A or B		260		179.5		142.5		107		ns
t_{dis}	Disable Time	OE	A or B		260		200		250		250		ns
t_{rA}	Ouput Rise Time	B	A	Push-Pull	22.7		18.4		16.3		14.2		ns
				Open-Drain	221.5		173.3		145.9		119.4		
t_{rB}		A	B	Push-Pull	20.6		16.8		15.9		22.1		
				Open-Drain	148.1		108.4		81.6		55.5		
t_{fA}	Output Fall Time	B	A	Push-Pull	5.6		4.8		4.7		5		ns
				Open-Drain	6.1		5.5		5.8		6.4		
t_{fB}		A	B	Push-Pull	12		13.1		15.2		19.9		
				Open-Drain	13.2		15.4		19.1		26.7		

5.7 Switching Characteristics, $V_{CCA} = 1.5 \pm 0.1V$

PARAMETER		FROM	TO	TEST CONDITIONS	B-Port Supply Voltage (V_{CCB})												UNIT
					1.8 ± 0.15V			2.5 ± 0.2V			3.3 ± 0.3V			5.0 ± 0.5V			
					MIN	TYP	MAX	MIN	TYP	MAX	MIN	TYP	MAX	MIN	TYP	MAX	
t_{PHL}	Propagation Delay (Hight-to-Low)	A	B	Push-Pull	4			3.9			4.5			5.6			ns
				Open-Drain	4			4.3			5			6.4			
t_{PLH}	Propagation Delay (Low-to-High)			Push-Pull	9.1			6.8			6.2			6			
				Open-Drain	12.5			10.7			10.5			10.4			
t_{PHL}	Propagation Delay (Hight-to-Low)	B	A	Push-Pull	3			2.9			3.3			4.3			
				Open-Drain	3			3.1			3.5			4.7			
t_{PLH}	Propagation Delay (Low-to-High)			Push-Pull	1.8			1			0.3			1			
				Open-Drain	4			1			1			1			
t_{en}	Enable Time	OE	A or B		250			200			200			100			ns
t_{dis}	Disable Time	OE	A or B		250			200			250			160			
t_{rA}	Ouput Rise Time	B	A	Push-Pull	12.5			9.5			7.9			7			ns
				Open-Drain	166.3			130			102.1			73.7			
t_{rB}		A	B	Push-Pull	14.3			10.8			9.4			8.2			
				Open-Drain	150			110			79			43.1			
t_{fA}	Output Fall Time	B	A	Push-Pull	4			3.3			3.2			3.4			
				Open-Drain	4.1			3.5			3.5			3.8			
t_{fB}		A	B	Push-Pull	7			6.9			7.8			10			
				Open-Drain	7.2			7.5			8.8			11.5			

5.8 Switching Characteristics, $V_{CCA} = 1.8 \pm 0.15V$

PARAMETER		FROM	TO	TEST CONDITIONS	B-Port Supply Voltage (V_{CCB})												UNIT
					1.8 ± 0.15V			2.5 ± 0.2V			3.3 ± 0.3V			5.0 ± 0.5V			
					MIN	TYP	MAX	MIN	TYP	MAX	MIN	TYP	MAX	MIN	TYP	MAX	
t_{PHL}	Propagation Delay (Hight-to-Low)	A	B	Push-Pull	6			6			5.8			5.8			ns
				Open-Drain	8.8			8.8			9.6			10			
t_{PLH}	Propagation Delay (Low-to-High)			Push-Pull	8			7.7			6.8			7			
				Open-Drain	50			50			26			33			
t_{PHL}	Propagation Delay (Hight-to-Low)	B	A	Push-Pull	4.4			4.4			4.5			4.7			
				Open-Drain	5.3			5.3			4.4			4.5			
t_{PLH}	Propagation Delay (Low-to-High)			Push-Pull	5.3			5.3			4.5			4.7			
				Open-Drain	36			36			16			20			
t_{en}	Enable Time	OE	A or B		200			200			200			200			ns
t_{dis}	Disable Time	OE	A or B		250			200			250			200			ns
t_{rA}	Ouput Rise Time	B	A	Push-Pull	11.4			9.5			9.3			15			ns
				Open-Drain	199			199			150			109			
		A	B	Push-Pull	13.3			10.8			9.1			7.6			
				Open-Drain	186			186			112			58			
t_{fA}	Output Fall Time	B	A	Push-Pull	5.9			5.9			6			13.3			
				Open-Drain	6.9			6.9			6.4			6.1			
		A	B	Push-Pull	7.6			7.6			7.5			8.8			
				Open-Drain	13.8			13.8			16.2			16.2			

5.9 Switching Characteristics, $V_{CCA} = 2.5 \pm 0.2V$

PARAMETER		FROM	TO	TEST CONDITIONS	B-Port Supply Voltage (V_{CCB})												UNIT
					1.8 ± 0.15V			2.5 ± 0.2V			3.3 ± 0.3V			5.0 ± 0.5V			
					MIN	TYP	MAX	MIN	TYP	MAX	MIN	TYP	MAX	MIN	TYP	MAX	
t_{PHL}	Propagation Delay (Hight-to-Low)	A	B	Push-Pull	3.2			3.2			3.3			3.4			ns
				Open-Drain	6.3			6.3			6			5.8			
t_{PLH}	Propagation Delay (Low-to-High)			Push-Pull	3.8			3.8			4.1			4.4			
				Open-Drain	3.5			3.5			4.1			4.4			
t_{PHL}	Propagation Delay (Hight-to-Low)	B	A	Push-Pull	3			3			3.6			4.3			
				Open-Drain	4.7			4.7			4.2			4			
t_{PLH}	Propagation Delay (Low-to-High)			Push-Pull	8.7			2.5			1.6			0.7			
				Open-Drain	29.9			2.5			1.6			1			
t_{en}	Enable Time	OE	A or B		200			200			200			200			ns
t_{dis}	Disable Time	OE	A or B		250			200			200			200			
t_{rA}	Ouput Rise Time	B	A	Push-Pull	10.6			7.4			6.6			5.6			ns
				Open-Drain	180			180			150			105			
t_{rB}		A	B	Push-Pull	11.9			8.8			7.6			6.6			
				Open-Drain	170			170			120			64			
t_{fA}	Output Fall Time	B	A	Push-Pull	5.7			5.7			5.5			5.3			
				Open-Drain	5.8			5.8			5.8			5.8			
t_{fB}		A	B	Push-Pull	7.8			7.8			6.7			6.6			
				Open-Drain	8.8			8.8			9.4			10.4			

5.10 Switching Characteristics, $V_{CCA} = 3.3 \pm 0.3V$

PARAMETER		FROM	TO	TEST CONDITIONS	B-Port Supply Voltage (V_{CCB})												UNIT
					1.8 ± 0.15V			2.5 ± 0.2V			3.3 ± 0.3V			5.0 ± 0.5V			
					MIN	TYP	MAX	MIN	TYP	MAX	MIN	TYP	MAX	MIN	TYP	MAX	
t_{PHL}	Propagation Delay (Hight-to-Low)	A	B	Push-Pull	3.5			2.8			2.4			3.1			ns
				Open-Drain	4.2			4.2			4.2			4.6			
t_{PLH}	Propagation Delay (Low-to-High)			Push-Pull	4.2			4.2			4.2			4.4			
				Open-Drain	4.2			4.2			4.2			4.4			
t_{PHL}	Propagation Delay (Hight-to-Low)	B	A	Push-Pull	2.9			2.5			2.5			3.3			
				Open-Drain	124			124			124			97			
t_{PLH}	Propagation Delay (Low-to-High)			Push-Pull	10			5			2.5			2.6			
				Open-Drain	27.5			15			2.5			3.3			
t_{en}	Enable Time	OE	A or B	-40°C to 125°C	200			200			200			200			ns
t_{dis}	Disable Time				250			200			250			200			
t_{rA}	Ouput Rise Time	B	A		Push-Pull	11.6			6.9			5.8			5		
					Open-Drain	140			140			140			102		
t_{rB}		A	B		Push-Pull	11.3			8.1			6.8			7.4		
					Open-Drain	135			130			130			75		
t_{fA}	Output Fall Time	B	A		Push-Pull	5.4			5.4			5.4			5		
					Open-Drain	6.1			6.1			6.1			5.7		
t_{fB}		A	B		Push-Pull	7.4			7.4			7.4			7.6		
					Open-Drain	7.6			7.6			7.6			8.3		

over operating free-air temperature range (unless otherwise noted)

PARAMETER	TEST CONDITIONS		V _{CCA}	V _{CCB}	Operating free-air temperature (T _A)			UNIT
					-40°C to 125°C			
					MIN	TYP	MAX	
t _w	Pulse Duration, Data Inputs	Push-Pull Driving	1.2V ± 0.1V to 3.3V ± 0.3V	1.8V ± 0.15V to 5.5V ± 0.5V	41			ns
		Open-Drain Driving	1.2V ± 0.1V to 3.3V ± 0.3V	1.8V ± 0.15V to 5.5V ± 0.5V	500			
t _{sk} - Output skew	Skew between any two outputs of the same package switching in the same direction	Push-Pull Driving	1.65V to 3.6V	2.3V to 5.5V	1			ns
		Open-Drain Driving	1.65V to 3.6V	2.3V to 5.5V	1			

5.12 Typical Characteristics

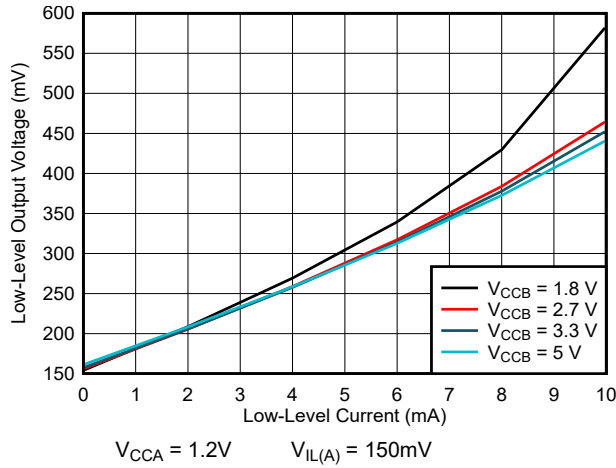

Figure 5-1. Low-Level Output Voltage ($V_{OL(Ax)}$) vs Low-Level Current ($I_{OL(Ax)}$)

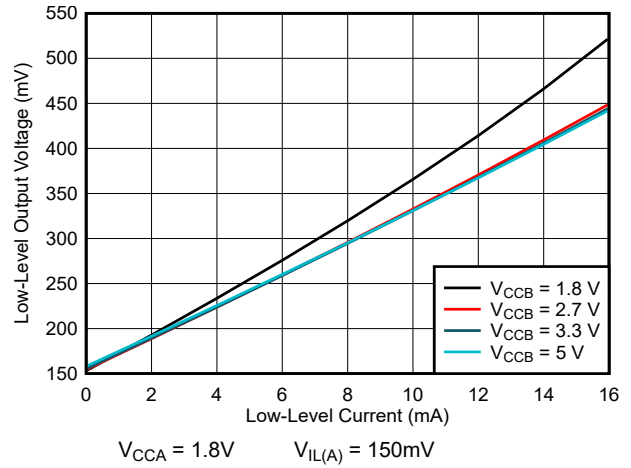

Figure 5-2. Low-Level Output Voltage ($V_{OL(Ax)}$) vs Low-Level Current ($I_{OL(Ax)}$)

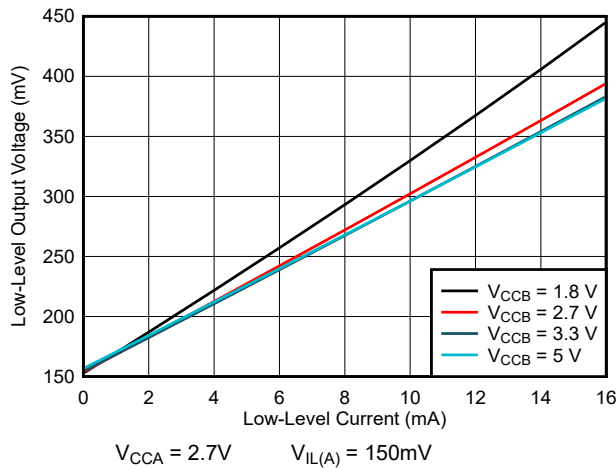

Figure 5-3. Low-Level Output Voltage ($V_{OL(Ax)}$) vs Low-Level Current ($I_{OL(Ax)}$)

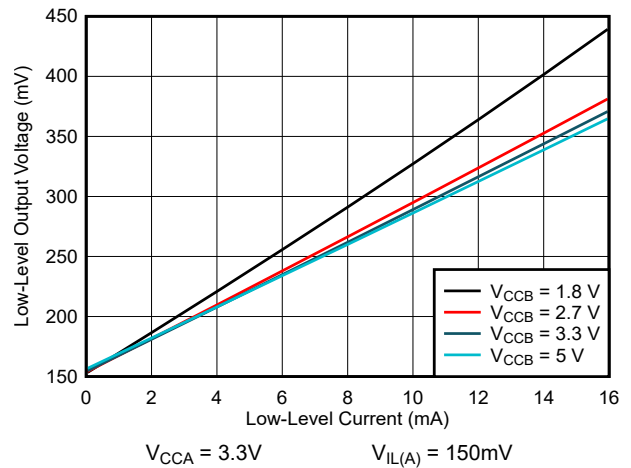

Figure 5-4. Low-Level Output Voltage ($V_{OL(Ax)}$) vs Low-Level Current ($I_{OL(Ax)}$)

6 Parameter Measurement Information

6.1 Load Circuits

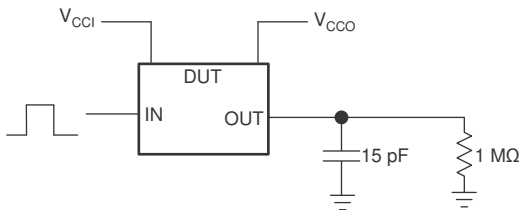

Figure 6-1. Data Rate, Pulse Duration, Propagation Delay, Output Rise-Time and Fall-Time Measurement Using a Push-Pull Driver

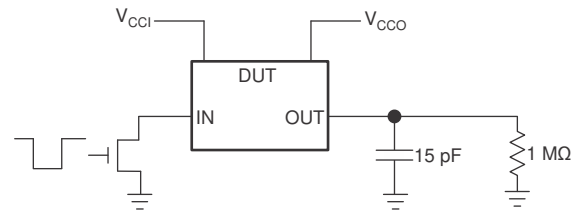
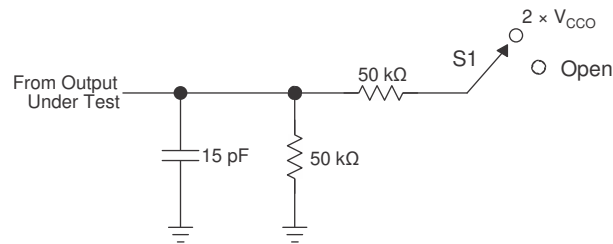

Figure 6-2. Data Rate, Pulse Duration, Propagation Delay, Output Rise-Time and Fall-Time Measurement Using an Open-Drain Driver



TEST	S1
t_{PZL} / t_{PLZ} (t_{dis})	$2 \times V_{CCO}$
t_{PHZ} / t_{PZH} (t_{en})	Open

Figure 6-3. Load Circuit for Enable-Time and Disable-Time Measurement

1. t_{PLZ} and t_{PHZ} are the same as t_{dis} .
2. t_{PZL} and t_{PZH} are the same as t_{en} .
3. V_{CCI} is the V_{CC} associated with the input port.
4. V_{CCO} is the V_{CC} associated with the output port.

6.2 Voltage Waveforms

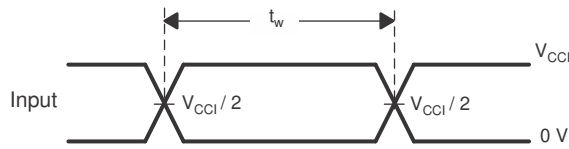

Figure 6-4. Pulse Duration

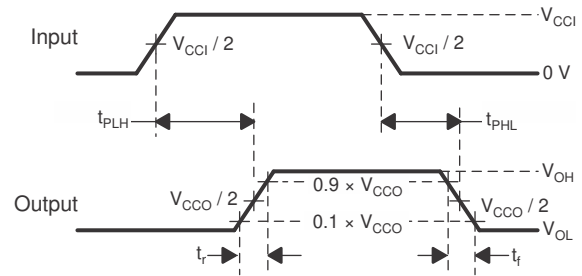
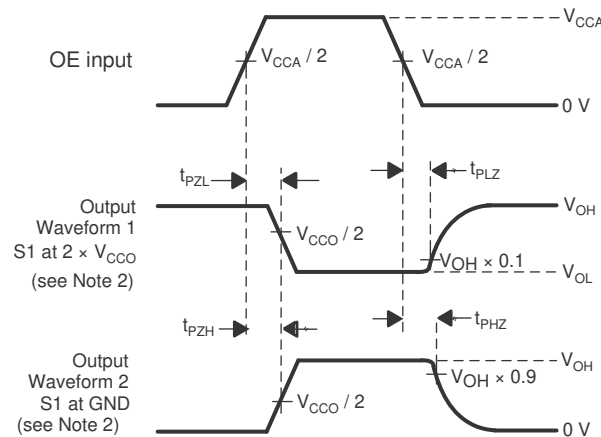

Figure 6-5. Propagation Delay Times



1. C_L includes probe and jig capacitance.
2. Waveform 1 in Figure 6-6 is for an output with internal such that the output is high, except when OE is high (see Figure 6-3). Waveform 2 in Figure 6-6 is for an output with conditions such that the output is low, except when OE is high.
3. All input pulses are supplied by generators having the following characteristics: $PRR \leq 10\text{MHz}$, $Z_O = 50\Omega$, $dv/dt \geq 1\text{V/ns}$.
4. The outputs are measured one at a time, with one transition per measurement.
5. t_{PLZ} and t_{PHZ} are the same as t_{dis} .
6. t_{PZL} and t_{PZH} are the same as t_{en} .
7. t_{PLH} and t_{PHL} are the same as t_{pd} .
8. V_{CCI} is the V_{CC} associated with the input port.
9. V_{CCO} is the V_{CC} associated with the output port.

Figure 6-6. Enable and Disable Times

7 Detailed Description

7.1 Overview

The TXS0104W-Q1 device is a directionless voltage-level translator specifically designed for translating logic voltage levels. The A port is able to accept I/O voltages ranging from 1.2V to 3.6V, while the B port can accept I/O voltages from 1.65V to 5.5V. The device is a pass gate architecture with edge rate accelerators (one shots) to improve the overall data rate. 10kΩ pullup resistors, commonly used in open drain applications, have been conveniently integrated so that an external resistor is not needed. While this device is designed for open drain applications, the device can also translate push-pull CMOS logic outputs.

7.2 Functional Block Diagram

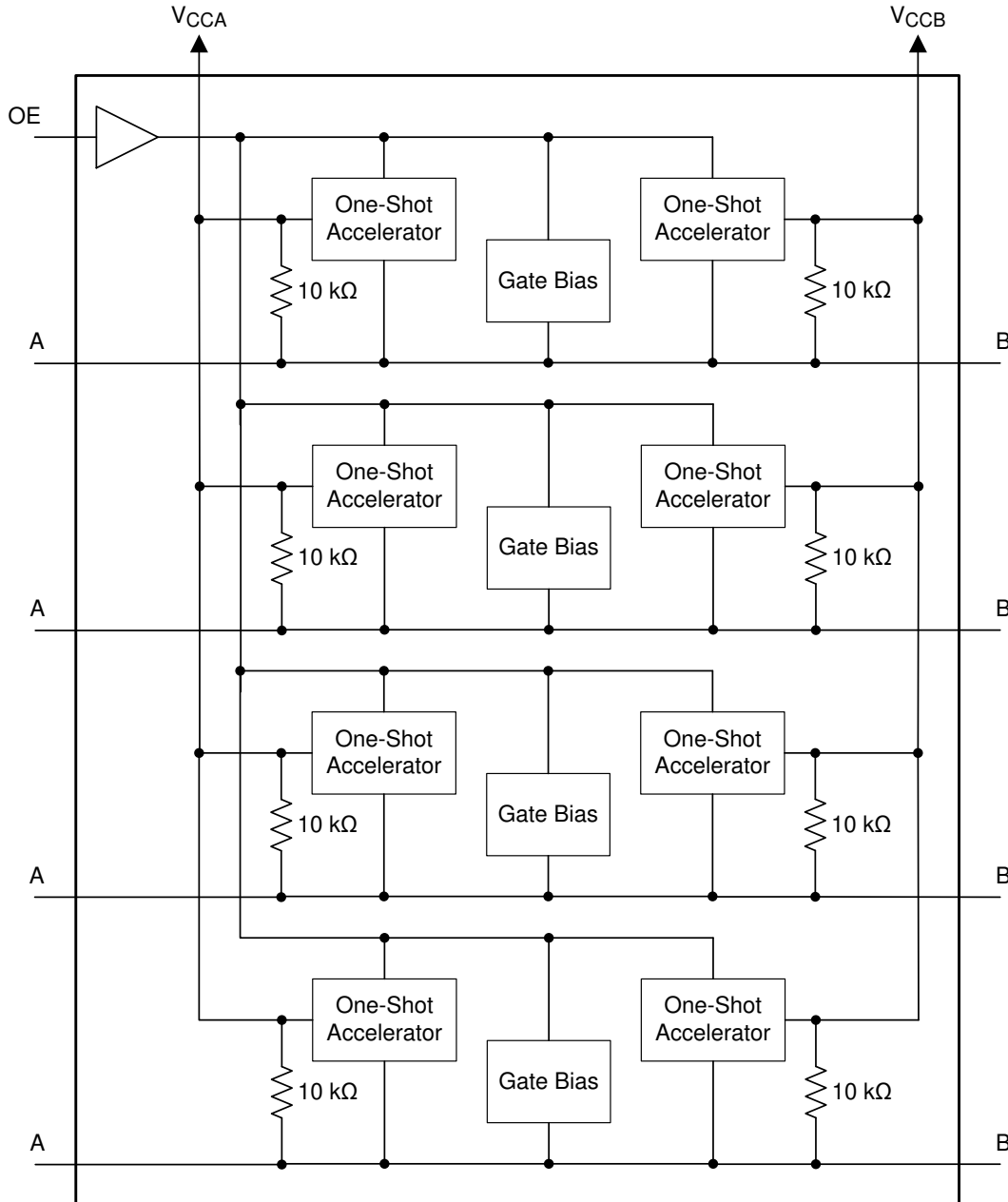

Copyright © 2016, Texas Instruments Incorporated

7.3 Feature Description

7.3.1 Architecture

The TXS0104W-Q1 architecture (see [Figure 7-1](#)) does not require a direction-control signal in order to control the direction of data flow from A to B or from B to A.

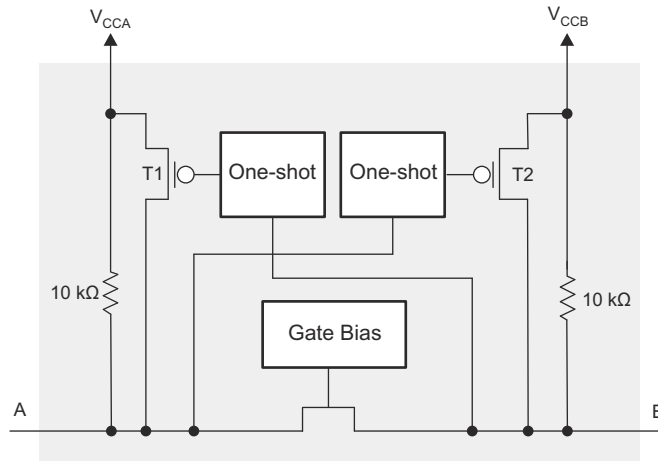

Figure 7-1. Architecture of a TXS0104W-Q1 Cell

Each A-port I/O has an internal 10kΩ pullup resistor to V_{CCA} , and each B-port I/O has an internal 10kΩ pullup resistor to V_{CCB} . The output one-shots detect rising edges on the A or B ports. During a rising edge, the one-shot turns on the PMOS transistors (T1, T2) for a short duration which speeds up the low-to-high transition.

7.3.2 Input Driver Requirements

The fall time (t_{fA} , t_{fB}) of a signal depends on the output impedance of the external device driving the data I/Os of the TXS0104W-Q1 device. Similarly, the t_{pHL} and maximum data rates also depend on the output impedance of the external driver. The values for t_{fA} , t_{fB} , t_{pHL} , and maximum data rates in the data sheet assume that the output impedance of the external driver is less than 50Ω.

7.3.3 Enable and Disable

The TXS0104W-Q1 device has an OE input that disables the device by setting OE low, which places all I/Os in the high-impedance state. The disable time (t_{dis}) indicates the delay between the time when the OE pin goes low and when the outputs actually enter the high-impedance state. The enable time (t_{en}) indicates the amount of time the user must allow for the one-shot circuitry to become operational after the OE pin is taken high.

7.3.4 Pull Up and Pull Down Resistors on I/O Lines

Each A-port I/O has an internal 10kΩ pullup resistor to V_{CCA} , and each B-port I/O has an internal 10-kΩ pullup resistor to V_{CCB} . If a smaller value of pullup resistor is required, an external resistor must be added from the I/O to V_{CCA} or V_{CCB} (in parallel with the internal 10kΩ resistors).

7.4 Device Functional Modes

The TXS0104W-Q1 device has two functional modes, enabled and disabled. To disable the device set the OE input low, which places all I/Os in a high impedance state. Setting the OE input high will enable the device.

8 Application and Implementation

Note

Information in the following applications sections is not part of the TI component specification, and TI does not warrant its accuracy or completeness. TI's customers are responsible for determining suitability of components for their purposes, as well as validating and testing their design implementation to confirm system functionality.

8.1 Application Information

The TXS0104W-Q1 device can be used in level-translation applications for interfacing devices or systems operating at different interface voltages with one another. The TXS0104W-Q1 device is optimal for use in applications where an open-drain driver is connected to the data I/Os. The TXS0104W-Q1 device can also be used in applications where a push-pull driver is connected to the data I/Os, but the TXB0104-Q1 device might be a better option for such push-pull applications.

8.2 Typical Application

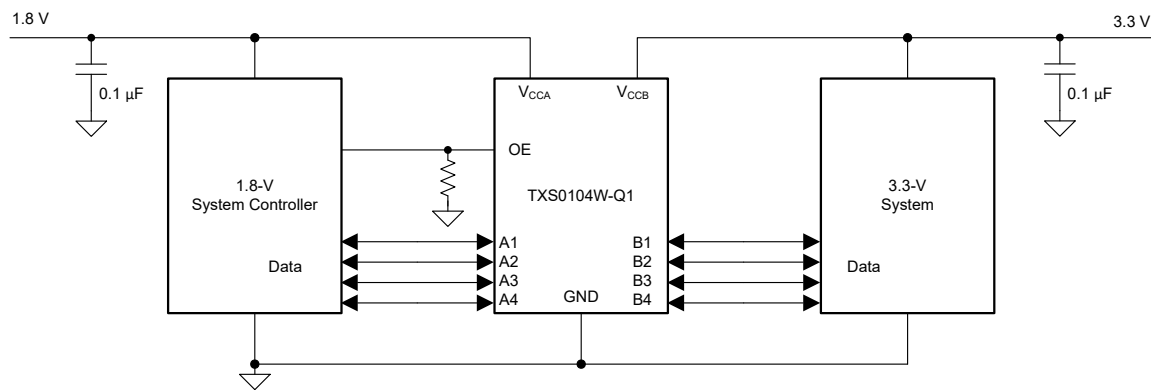

Figure 8-1. Application Schematic

8.2.1 Design Requirements

For this design example, use the parameters listed in [Table 8-1](#).

Table 8-1. Design Parameters

DESIGN PARAMETER	EXAMPLE VALUE
Input voltage range	1.2 to 3.6V
Output voltage range	1.65 to 5.5V

8.2.2 Detailed Design Procedure

To begin the design process, determine the following:

- Input voltage range
 - Use the supply voltage of the device that is driving the TXS0104W-Q1 device to determine the input voltage range. For a valid logic high the value must exceed the V_{IH} of the input port. For a valid logic low the value must be less than the V_{IL} of the input port.
- Output voltage range
 - Use the supply voltage of the device that the TXS0104W-Q1 device is driving to determine the output voltage range.
 - The TXS0104W-Q1 device has 10k Ω internal pullup resistors. External pullup resistors can be added to reduce the total RC of a signal trace if necessary.

- An external pull down resistor decreases the output V_{OH} and V_{OL} . Use [Equation 1](#) to calculate the V_{OH} as a result of an external pull down resistor.

$$V_{OH} = V_{CCx} \times R_{PD} / (R_{PD} + 10\text{ k}\Omega) \quad (1)$$

where

- V_{CCx} is the supply voltage on either V_{CCA} or V_{CCB}
- R_{PD} is the value of the external pull down resistor

8.2.3 Application Curve

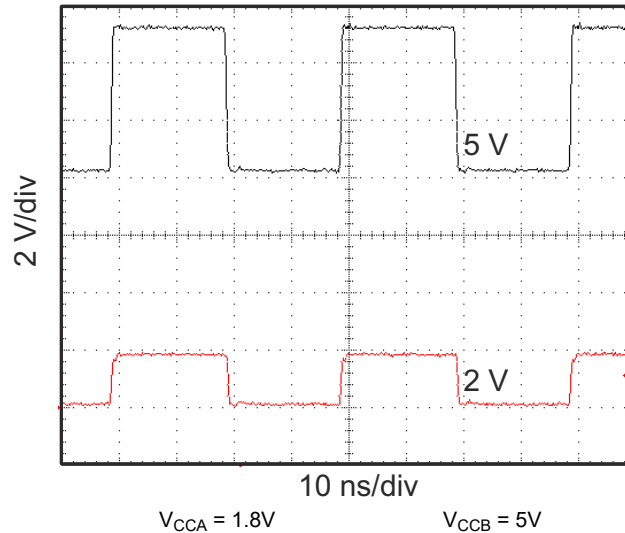

Figure 8-2. Level-Translation of a 2.5MHz Signal

8.3 Power Supply Recommendations

The TXS0104W-Q1 device uses two separate configurable power-supply rails, V_{CCA} and V_{CCB} . V_{CCB} accepts any supply voltage from 1.65V to 5.5V and V_{CCA} accepts any supply voltage from 1.2V to 3.6V. The A port and B port are designed to track V_{CCA} and V_{CCB} respectively allowing for low-voltage bidirectional translation between any of the 1.8V, 2.5V, 3.3V, and 5V voltage nodes.

The TXS0104W-Q1 device does not require power sequencing between V_{CCA} and V_{CCB} during power-up so the power-supply rails can be ramped in any order. A V_{CCA} value greater than or equal to V_{CCB} ($V_{CCA} \geq V_{CCB}$) does not damage the device, and during operation, V_{CCA} can be greater than, less than, or equal to V_{CCB} .

The output-enable (OE) input circuit is designed so that it is supplied by V_{CCA} and when the (OE) input is low, all outputs are placed in the high-impedance state. To enable the high-impedance state of the outputs during power up or power down, the OE input pin must be tied to GND through a pull down resistor and must not be enabled until V_{CCA} and V_{CCB} are fully ramped and stable. The minimum value of the pull down resistor to ground is determined by the current-sourcing capability of the driver.

8.4 Layout

8.4.1 Layout Guidelines

For reliability of the device, following common printed-circuit board layout guidelines is recommended.

- Bypass capacitors should be used on power supplies.
- Short trace lengths should be used to avoid excessive loading.
- PCB signal trace-lengths must be kept short enough so that the round-trip delay of any reflection is less than the one shot duration, approximately 30ns, ensuring that any reflection encounters low impedance at the source driver.
- Placing pads on the signal paths for loading capacitors or pullup resistors to help adjust rise and fall times of signals depending on the system requirements

8.4.2 Layout Example

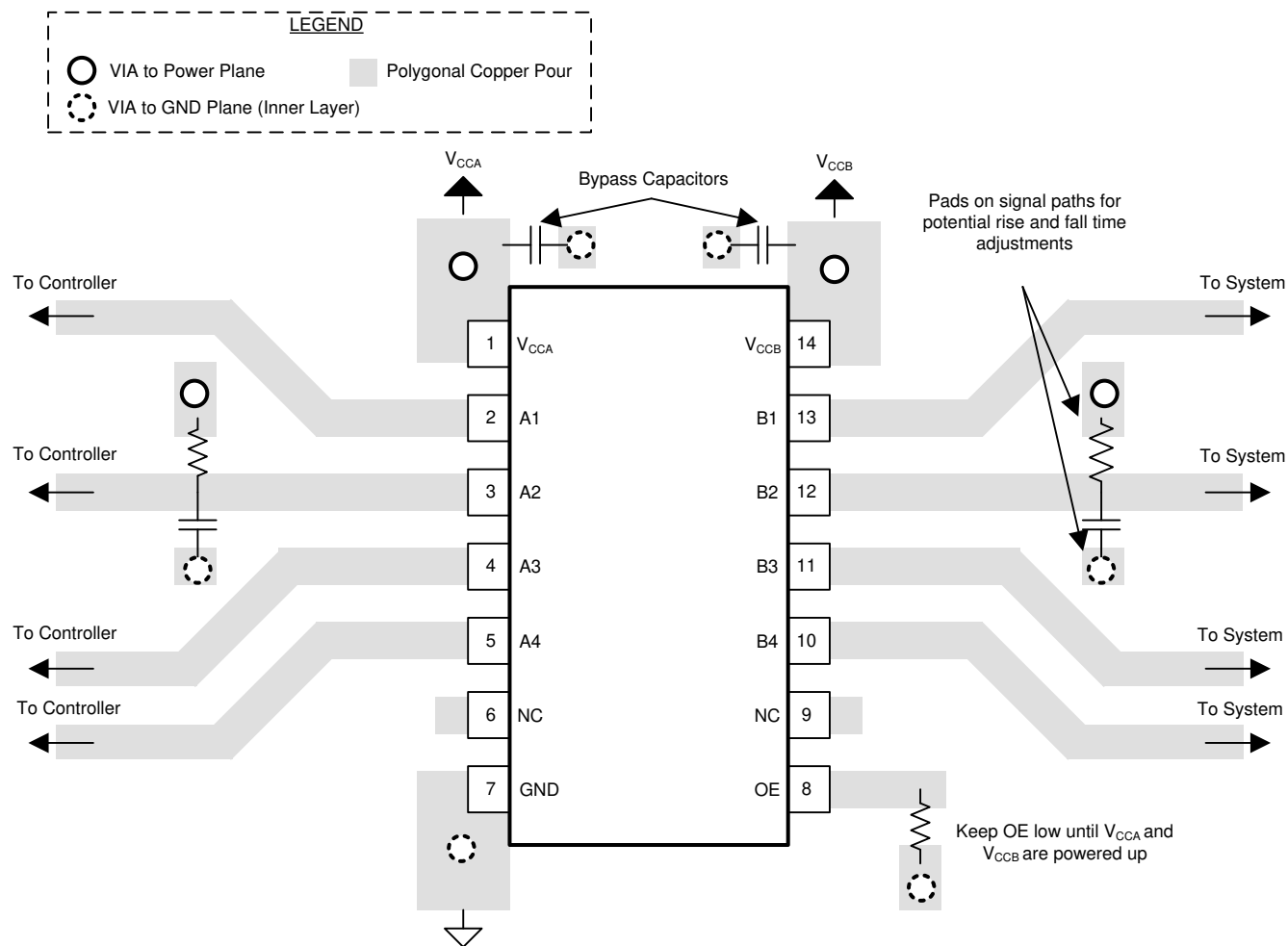

Figure 8-3. TXS0104W-Q1 Layout Example

9 Device and Documentation Support

9.1 Documentation Support

9.1.1 Related Documentation

For related documentation, see the following:

- Texas Instruments, [Introduction to Logic application note](#)

9.2 Receiving Notification of Documentation Updates

To receive notification of documentation updates, navigate to the device product folder on ti.com. Click on *Notifications* to register and receive a weekly digest of any product information that has changed. For change details, review the revision history included in any revised document.

9.3 Support Resources

[TI E2E™ support forums](#) are an engineer's go-to source for fast, verified answers and design help — straight from the experts. Search existing answers or ask your own question to get the quick design help you need.

Linked content is provided "AS IS" by the respective contributors. They do not constitute TI specifications and do not necessarily reflect TI's views; see TI's [Terms of Use](#).

9.4 Trademarks

TI E2E™ is a trademark of Texas Instruments.
All trademarks are the property of their respective owners.

10 Electrostatic Discharge Caution



This integrated circuit can be damaged by ESD. Texas Instruments recommends that all integrated circuits be handled with appropriate precautions. Failure to observe proper handling and installation procedures can cause damage.

ESD damage can range from subtle performance degradation to complete device failure. Precision integrated circuits may be more susceptible to damage because very small parametric changes could cause the device not to meet its published specifications.

11 Glossary

[TI Glossary](#) This glossary lists and explains terms, acronyms, and definitions.

12 Revision History

NOTE: Page numbers for previous revisions may differ from page numbers in the current version.

Changes from Revision * (July 2025) to Revision A (January 2026)	Page
• First public release of the data sheet.....	1

DATE	REVISION	NOTES
July 2025	*	Initial Release

13 Mechanical, Packaging, and Orderable Information

The following pages include mechanical, packaging, and orderable information. This information is the most current data available for the designated devices. This data is subject to change without notice and revision of this document. For browser-based versions of this data sheet, refer to the left-hand navigation.

PACKAGING INFORMATION

Orderable part number	Status (1)	Material type (2)	Package Pins	Package qty Carrier	RoHS (3)	Lead finish/ Ball material (4)	MSL rating/ Peak reflow (5)	Op temp (°C)	Part marking (6)
TXS0104WQPWRQ1	Active	Production	TSSOP (PW) 14	2000 LARGE T&R	Yes	NIPDAU	Level-1-260C-UNLIM	-40 to 125	04WQ1

(1) **Status:** For more details on status, see our [product life cycle](#).

(2) **Material type:** When designated, preproduction parts are prototypes/experimental devices, and are not yet approved or released for full production. Testing and final process, including without limitation quality assurance, reliability performance testing, and/or process qualification, may not yet be complete, and this item is subject to further changes or possible discontinuation. If available for ordering, purchases will be subject to an additional waiver at checkout, and are intended for early internal evaluation purposes only. These items are sold without warranties of any kind.

(3) **RoHS values:** Yes, No, RoHS Exempt. See the [TI RoHS Statement](#) for additional information and value definition.

(4) **Lead finish/Ball material:** Parts may have multiple material finish options. Finish options are separated by a vertical ruled line. Lead finish/Ball material values may wrap to two lines if the finish value exceeds the maximum column width.

(5) **MSL rating/Peak reflow:** The moisture sensitivity level ratings and peak solder (reflow) temperatures. In the event that a part has multiple moisture sensitivity ratings, only the lowest level per JEDEC standards is shown. Refer to the shipping label for the actual reflow temperature that will be used to mount the part to the printed circuit board.

(6) **Part marking:** There may be an additional marking, which relates to the logo, the lot trace code information, or the environmental category of the part.

Multiple part markings will be inside parentheses. Only one part marking contained in parentheses and separated by a "-" will appear on a part. If a line is indented then it is a continuation of the previous line and the two combined represent the entire part marking for that device.

Important Information and Disclaimer:The information provided on this page represents TI's knowledge and belief as of the date that it is provided. TI bases its knowledge and belief on information provided by third parties, and makes no representation or warranty as to the accuracy of such information. Efforts are underway to better integrate information from third parties. TI has taken and continues to take reasonable steps to provide representative and accurate information but may not have conducted destructive testing or chemical analysis on incoming materials and chemicals. TI and TI suppliers consider certain information to be proprietary, and thus CAS numbers and other limited information may not be available for release.

In no event shall TI's liability arising out of such information exceed the total purchase price of the TI part(s) at issue in this document sold by TI to Customer on an annual basis.

OTHER QUALIFIED VERSIONS OF TXS0104W-Q1 :

- Catalog : [TXS0104W](#)

NOTE: Qualified Version Definitions:

- Catalog - TI's standard catalog product

TAPE AND REEL INFORMATION

QUADRANT ASSIGNMENTS FOR PIN 1 ORIENTATION IN TAPE

*All dimensions are nominal

Device	Package Type	Package Drawing	Pins	SPQ	Reel Diameter (mm)	Reel Width W1 (mm)	A0 (mm)	B0 (mm)	K0 (mm)	P1 (mm)	W (mm)	Pin1 Quadrant
TXS0104WQPWRQ1	TSSOP	PW	14	2000	330.0	12.4	6.9	5.6	1.6	8.0	12.0	Q1

TAPE AND REEL BOX DIMENSIONS

*All dimensions are nominal

Device	Package Type	Package Drawing	Pins	SPQ	Length (mm)	Width (mm)	Height (mm)
TXS0104WQPWRQ1	TSSOP	PW	14	2000	353.0	353.0	32.0



NOTES:

1. All linear dimensions are in millimeters. Any dimensions in parenthesis are for reference only. Dimensioning and tolerancing per ASME Y14.5M.
2. This drawing is subject to change without notice.
3. This dimension does not include mold flash, protrusions, or gate burrs. Mold flash, protrusions, or gate burrs shall not exceed 0.15 mm per side.
4. This dimension does not include interlead flash. Interlead flash shall not exceed 0.25 mm per side.
5. Reference JEDEC registration MO-153.

EXAMPLE BOARD LAYOUT

PW0014A

TSSOP - 1.2 mm max height

SMALL OUTLINE PACKAGE



LAND PATTERN EXAMPLE
EXPOSED METAL SHOWN
SCALE: 10X



4220202/B 12/2023

NOTES: (continued)

- 6. Publication IPC-7351 may have alternate designs.
- 7. Solder mask tolerances between and around signal pads can vary based on board fabrication site.

EXAMPLE STENCIL DESIGN

PW0014A

TSSOP - 1.2 mm max height

SMALL OUTLINE PACKAGE



SOLDER PASTE EXAMPLE
BASED ON 0.125 mm THICK STENCIL
SCALE: 10X

4220202/B 12/2023

NOTES: (continued)

8. Laser cutting apertures with trapezoidal walls and rounded corners may offer better paste release. IPC-7525 may have alternate design recommendations.
9. Board assembly site may have different recommendations for stencil design.

IMPORTANT NOTICE AND DISCLAIMER

TI PROVIDES TECHNICAL AND RELIABILITY DATA (INCLUDING DATASHEETS), DESIGN RESOURCES (INCLUDING REFERENCE DESIGNS), APPLICATION OR OTHER DESIGN ADVICE, WEB TOOLS, SAFETY INFORMATION, AND OTHER RESOURCES "AS IS" AND WITH ALL FAULTS, AND DISCLAIMS ALL WARRANTIES, EXPRESS AND IMPLIED, INCLUDING WITHOUT LIMITATION ANY IMPLIED WARRANTIES OF MERCHANTABILITY, FITNESS FOR A PARTICULAR PURPOSE OR NON-INFRINGEMENT OF THIRD PARTY INTELLECTUAL PROPERTY RIGHTS.

These resources are intended for skilled developers designing with TI products. You are solely responsible for (1) selecting the appropriate TI products for your application, (2) designing, validating and testing your application, and (3) ensuring your application meets applicable standards, and any other safety, security, regulatory or other requirements.

These resources are subject to change without notice. TI grants you permission to use these resources only for development of an application that uses the TI products described in the resource. Other reproduction and display of these resources is prohibited. No license is granted to any other TI intellectual property right or to any third party intellectual property right. TI disclaims responsibility for, and you fully indemnify TI and its representatives against any claims, damages, costs, losses, and liabilities arising out of your use of these resources.

TI's products are provided subject to [TI's Terms of Sale](#), [TI's General Quality Guidelines](#), or other applicable terms available either on ti.com or provided in conjunction with such TI products. TI's provision of these resources does not expand or otherwise alter TI's applicable warranties or warranty disclaimers for TI products. Unless TI explicitly designates a product as custom or customer-specified, TI products are standard, catalog, general purpose devices.

TI objects to and rejects any additional or different terms you may propose.

Copyright © 2026, Texas Instruments Incorporated

Last updated 10/2025