

# UCC218200-Q1 15A Source/Sink Reinforced Isolated Single Channel Gate Driver for SiC/IGBT with Advanced Protection

## 1 Features

- 5kV<sub>RMS</sub> single channel isolated gate driver
- AEC-Q100 qualified for automotive applications
- SiC MOSFETs and IGBTs up to 1500V<sub>pk</sub>
- 30V maximum output drive voltage (VDD-VEE)
- ±15A drive strength with split output
- 200-V/ns minimum CMTI
- 200ns response time fast DESAT protection with 9V threshold
- Dedicated Soft Shut Down (SSD) pin with 2.5A sinking capability. Shut down current is controllable by an external resistor.
- 4A internal active Miller clamp
- Overcurrent reporting on  $\overline{FLT}$  and reset from  $\overline{RST/EN}$
- Fast enable/disable response on  $\overline{RST/EN}$
- 12V VDD UVLO and -3V VEE UVLO with power good on RDY
- Overtemperature protection with power good on RDY
- Output voltage gate monitor with real-time output state feedback on OUT\_FB.
- Active short circuit (ASC) inputs on both primary and secondary sides to turn on power switch during system fault.
- Built-in self test diagnostics during power up for DESAT, UVLO, and output voltage gate monitor comparators.
- 20-Pin DFP wide body package with creepage and clearance distance > 8mm
- Operating junction temperature -40°C to 150°C

well as providing low part-to-part skew, and >200V/ns common-mode noise immunity (CMTI).

The UCC218200-Q1 includes state-of-art protection features such as fast overcurrent and short circuit detection, controlled soft shutdown after a fault, fault reporting, active Miller clamp, input and output side power supply UVLO to optimize SiC and IGBT switching behavior and robustness, active short circuit inputs on both the primary and secondary sides, output voltage gate monitoring, and built-in self test during startup.

### Package Information

PART NUMBER	PACKAGE <sup>(1)</sup>	BODY SIZE (NOM)
UCC218200B-Q1	DFP (SSOP 20)	5.6 mm × 7.5 mm

(1) For all available packages, see [Section 6](#)

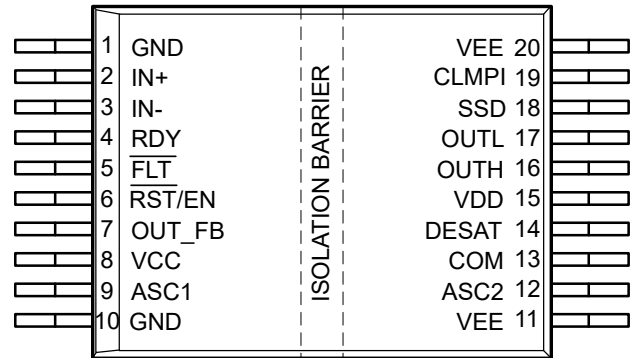

Device Pin Configuration

## 2 Applications

- [Traction inverter for EVs](#)
- [On-board charger and charging pile](#)
- [DC-DC converter for HEV/EVs](#)

## 3 Description

The UCC218200-Q1 is a galvanically isolated single-channel gate driver designed for SiC MOSFETs and IGBTs up to 1500V DC operating voltage with advanced protection features, best-in-class dynamic performance, and robustness. The UCC218200-Q1 has up to ±15A peak source and sink current.

The input side is isolated from the output side with SiO<sub>2</sub> isolation technology, supporting up to 1.06kV<sub>RMS</sub> working voltage, 10kV<sub>PK</sub> surge immunity with longer than 40-years isolation barrier life, as

## 4 Device and Documentation Support

### 4.1 Third-Party Products Disclaimer

TI'S PUBLICATION OF INFORMATION REGARDING THIRD-PARTY PRODUCTS OR SERVICES DOES NOT CONSTITUTE AN ENDORSEMENT REGARDING THE SUITABILITY OF SUCH PRODUCTS OR SERVICES OR A WARRANTY, REPRESENTATION OR ENDORSEMENT OF SUCH PRODUCTS OR SERVICES, EITHER ALONE OR IN COMBINATION WITH ANY TI PRODUCT OR SERVICE.

### 4.2 Documentation Support

#### 4.2.1 Related Documentation

For related documentation see the following:

- [Isolation Glossary](#)

### 4.3 Receiving Notification of Documentation Updates

To receive notification of documentation updates, navigate to the device product folder on ti.com. In the upper right corner, click on *Alert me* to register and receive a weekly digest of any product information that has changed. For change details, review the revision history included in any revised document.

### 4.4 Support Resources

TI E2E™ [support forums](#) are an engineer's go-to source for fast, verified answers and design help — straight from the experts. Search existing answers or ask your own question to get the quick design help you need.

Linked content is provided "AS IS" by the respective contributors. They do not constitute TI specifications and do not necessarily reflect TI's views; see TI's [Terms of Use](#).

### 4.5 Trademarks

TI E2E™ is a trademark of Texas Instruments.  
All trademarks are the property of their respective owners.

### 4.6 Electrostatic Discharge Caution



This integrated circuit can be damaged by ESD. Texas Instruments recommends that all integrated circuits be handled with appropriate precautions. Failure to observe proper handling and installation procedures can cause damage.

ESD damage can range from subtle performance degradation to complete device failure. Precision integrated circuits may be more susceptible to damage because very small parametric changes could cause the device not to meet its published specifications.

### 4.7 Glossary

[TI Glossary](#) This glossary lists and explains terms, acronyms, and definitions.

## 5 Revision History

NOTE: Page numbers for previous revisions may differ from page numbers in the current version.

DATE	REVISION	NOTES
May 2025	*	Initial Release

## 6 Mechanical, Packaging, and Orderable Information

The following pages include mechanical packaging and orderable information. This information is the most current data available for the designated devices. This data is subject to change without notice and revision of this document. For browser-based versions of this data sheet, refer to the left-hand navigation.

**6.1 Mechanical Data**

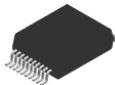
**DFP0020A**  **PACKAGE OUTLINE**  
**SSOP - 2.65 mm max height**  
SMALL OUTLINE PACKAGE

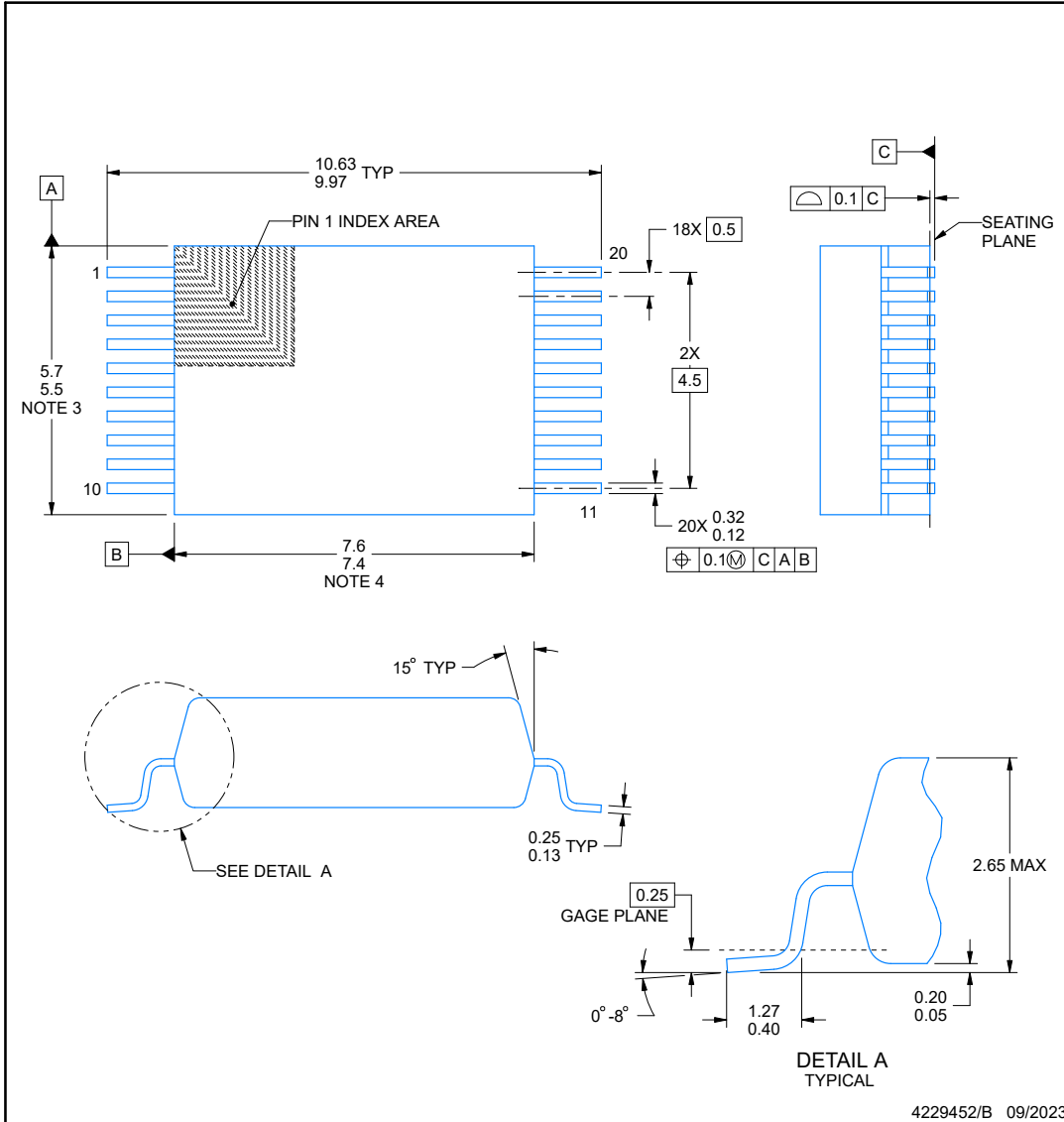

**NOTES:**

1. All linear dimensions are in millimeters. Any dimensions in parenthesis are for reference only. Dimensioning and tolerancing per ASME Y14.5M.
2. This drawing is subject to change without notice.
3. This dimension does not include mold flash, protrusions, or gate burrs. Mold flash, protrusions, or gate burrs shall not exceed 0.15 mm per side.
4. This dimension does not include interlead flash. Interlead flash shall not exceed 0.25 mm per side.

**EXAMPLE BOARD LAYOUT**

**DFP0020A**

**SSOP - 2.65 mm max height**

SMALL OUTLINE PACKAGE

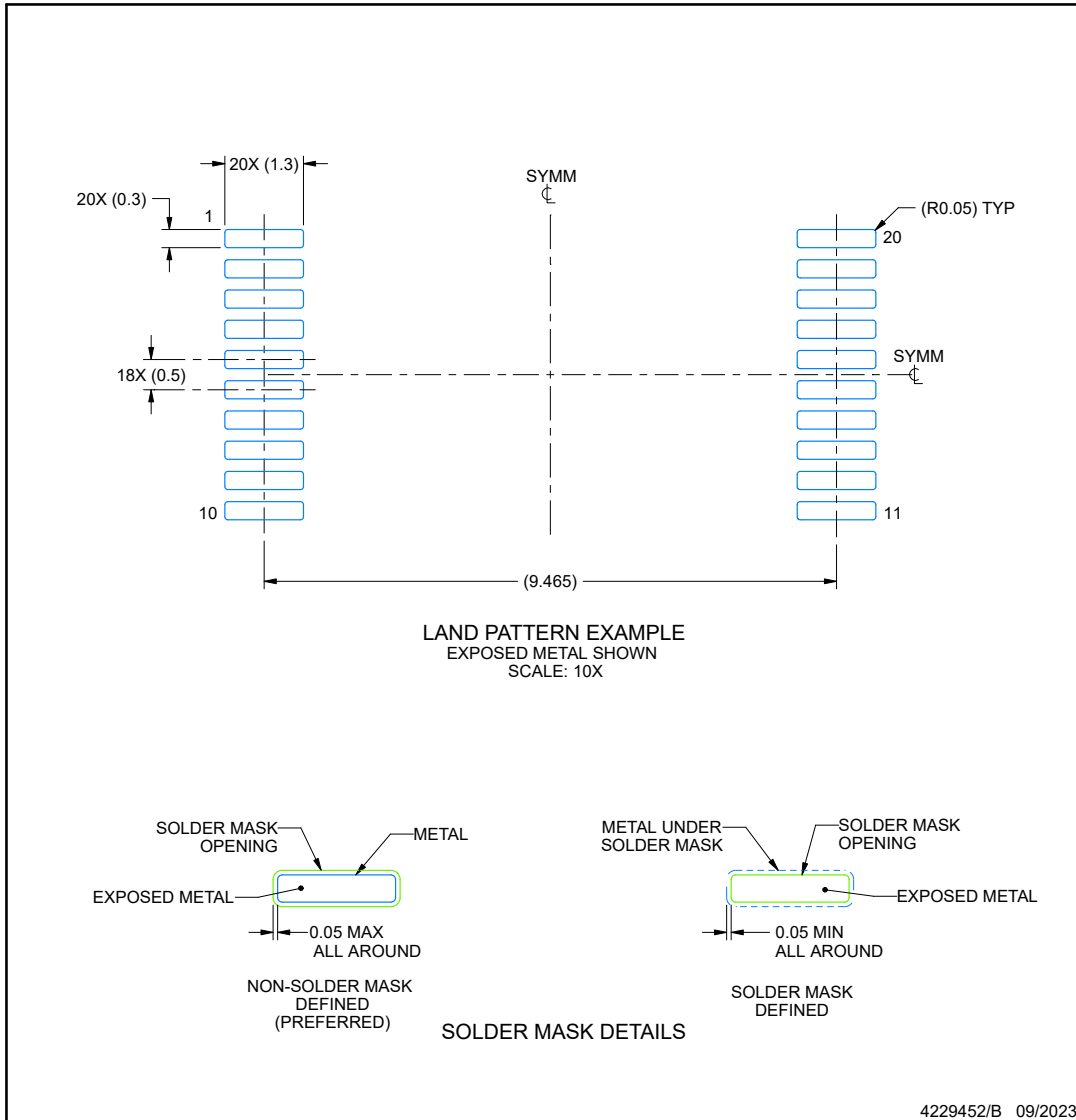

NOTES: (continued)

- 5. Publication IPC-7351 may have alternate designs.
- 6. Solder mask tolerances between and around signal pads can vary based on board fabrication site.

**EXAMPLE STENCIL DESIGN**

**DFP0020A**

**SSOP - 2.65 mm max height**

SMALL OUTLINE PACKAGE

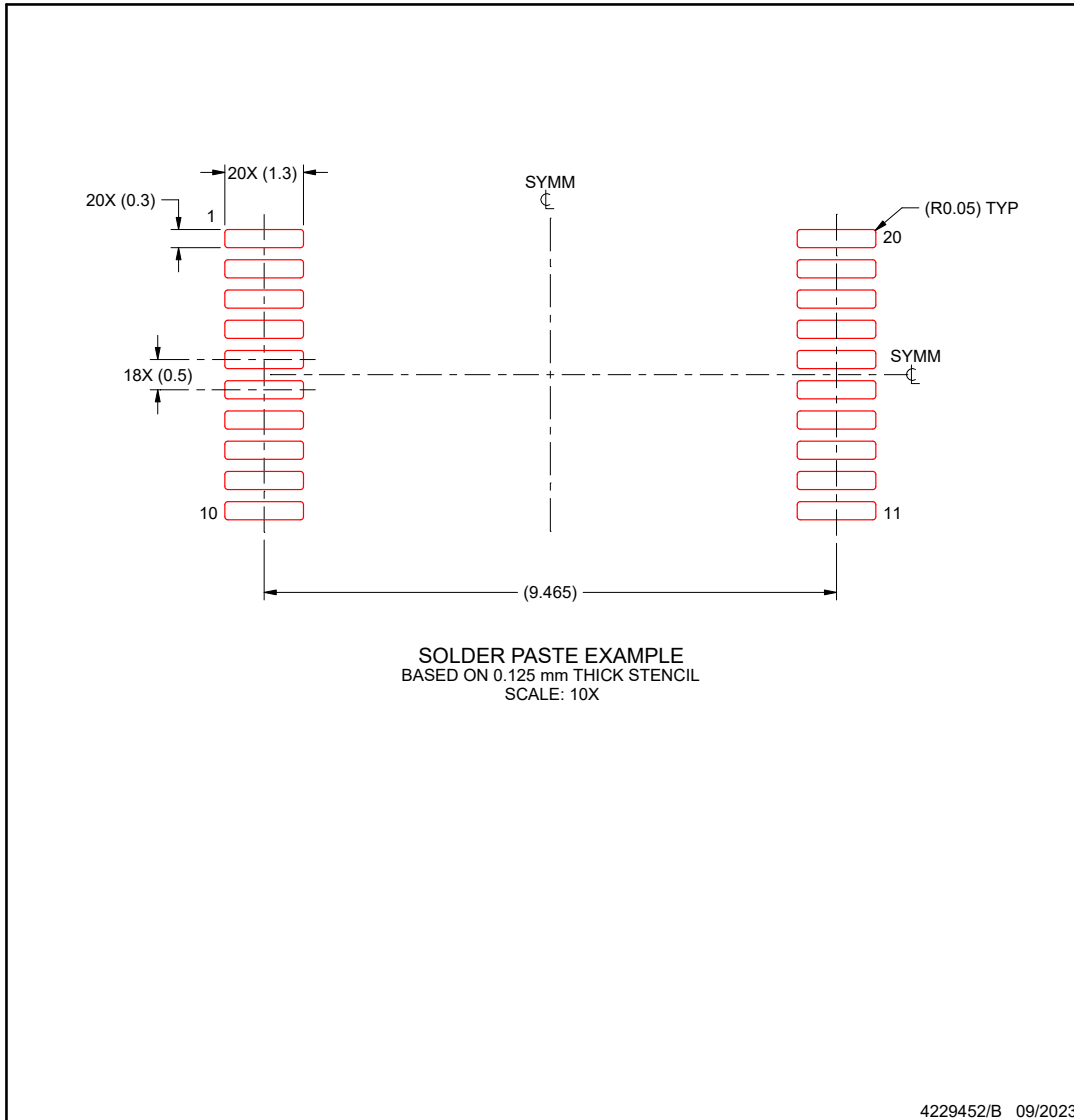

NOTES: (continued)

- 7. Laser cutting apertures with trapezoidal walls and rounded corners may offer better paste release. IPC-7525 may have alternate design recommendations.
- 8. Board assembly site may have different recommendations for stencil design.

**ADVANCE INFORMATION**

**PACKAGING INFORMATION**

Orderable part number	Status (1)	Material type (2)	Package   Pins	Package qty   Carrier	RoHS (3)	Lead finish/ Ball material (4)	MSL rating/ Peak reflow (5)	Op temp (°C)	Part marking (6)
<a href="#">PUCC218200BQDFPRQ1</a>	Active	Preproduction	SSOP (DFP)   20	3000   LARGE T&R	-	Call TI	Call TI	-40 to 150	

(1) **Status:** For more details on status, see our [product life cycle](#).

(2) **Material type:** When designated, preproduction parts are prototypes/experimental devices, and are not yet approved or released for full production. Testing and final process, including without limitation quality assurance, reliability performance testing, and/or process qualification, may not yet be complete, and this item is subject to further changes or possible discontinuation. If available for ordering, purchases will be subject to an additional waiver at checkout, and are intended for early internal evaluation purposes only. These items are sold without warranties of any kind.

(3) **RoHS values:** Yes, No, RoHS Exempt. See the [TI RoHS Statement](#) for additional information and value definition.

(4) **Lead finish/Ball material:** Parts may have multiple material finish options. Finish options are separated by a vertical ruled line. Lead finish/Ball material values may wrap to two lines if the finish value exceeds the maximum column width.

(5) **MSL rating/Peak reflow:** The moisture sensitivity level ratings and peak solder (reflow) temperatures. In the event that a part has multiple moisture sensitivity ratings, only the lowest level per JEDEC standards is shown. Refer to the shipping label for the actual reflow temperature that will be used to mount the part to the printed circuit board.

(6) **Part marking:** There may be an additional marking, which relates to the logo, the lot trace code information, or the environmental category of the part.

Multiple part markings will be inside parentheses. Only one part marking contained in parentheses and separated by a "-" will appear on a part. If a line is indented then it is a continuation of the previous line and the two combined represent the entire part marking for that device.

**Important Information and Disclaimer:** The information provided on this page represents TI's knowledge and belief as of the date that it is provided. TI bases its knowledge and belief on information provided by third parties, and makes no representation or warranty as to the accuracy of such information. Efforts are underway to better integrate information from third parties. TI has taken and continues to take reasonable steps to provide representative and accurate information but may not have conducted destructive testing or chemical analysis on incoming materials and chemicals. TI and TI suppliers consider certain information to be proprietary, and thus CAS numbers and other limited information may not be available for release.

In no event shall TI's liability arising out of such information exceed the total purchase price of the TI part(s) at issue in this document sold by TI to Customer on an annual basis.

## IMPORTANT NOTICE AND DISCLAIMER

TI PROVIDES TECHNICAL AND RELIABILITY DATA (INCLUDING DATASHEETS), DESIGN RESOURCES (INCLUDING REFERENCE DESIGNS), APPLICATION OR OTHER DESIGN ADVICE, WEB TOOLS, SAFETY INFORMATION, AND OTHER RESOURCES "AS IS" AND WITH ALL FAULTS, AND DISCLAIMS ALL WARRANTIES, EXPRESS AND IMPLIED, INCLUDING WITHOUT LIMITATION ANY IMPLIED WARRANTIES OF MERCHANTABILITY, FITNESS FOR A PARTICULAR PURPOSE OR NON-INFRINGEMENT OF THIRD PARTY INTELLECTUAL PROPERTY RIGHTS.

These resources are intended for skilled developers designing with TI products. You are solely responsible for (1) selecting the appropriate TI products for your application, (2) designing, validating and testing your application, and (3) ensuring your application meets applicable standards, and any other safety, security, regulatory or other requirements.

These resources are subject to change without notice. TI grants you permission to use these resources only for development of an application that uses the TI products described in the resource. Other reproduction and display of these resources is prohibited. No license is granted to any other TI intellectual property right or to any third party intellectual property right. TI disclaims responsibility for, and you fully indemnify TI and its representatives against any claims, damages, costs, losses, and liabilities arising out of your use of these resources.

TI's products are provided subject to [TI's Terms of Sale](#), [TI's General Quality Guidelines](#), or other applicable terms available either on [ti.com](http://ti.com) or provided in conjunction with such TI products. TI's provision of these resources does not expand or otherwise alter TI's applicable warranties or warranty disclaimers for TI products. Unless TI explicitly designates a product as custom or customer-specified, TI products are standard, catalog, general purpose devices.

TI objects to and rejects any additional or different terms you may propose.

Copyright © 2026, Texas Instruments Incorporated

Last updated 10/2025