

XTR11x 4-20 mA Current-Loop Transmitters

1 Features

- Low quiescent current: 200 μ A
- 5-V regulator for external circuits
- V_{REF} for sensor excitation:
 - XTR115: 2.5 V
 - XTR116: 4.096 V
- Low span error: 0.05%
- Low nonlinearity error: 0.003%
- Wide loop supply range: 7.5 V to 36 V
- SO-8 package

2 Applications

- 2-wire, 4-20-mA current loop
- Transmitter
- Smart transmitter
- Industrial process control
- Test systems
- Compatible with HART modem
- Current amplifier
- Voltage-to-current amplifier

3 Description

The XTR115 and XTR116 (XTR11x) are precision current output converters designed to transmit analog 4-mA-to-20-mA signals over an industry standard current loop. These devices provide accurate current scaling and output current limit functions.

The on-chip voltage regulator (5 V) can be used to power external circuitry. A precision on-chip V_{REF} (2.5 V for the XTR115 and 4.096 V for the XTR116) can be used for offsetting or to excite transducers. A current return pin (I_{RET}) senses any current used in external circuitry to provide an accurate control of the output current.

The XTR11x are a fundamental building block of smart sensors using 4-mA-to-20-mA current transmission.

The XTR11x are specified for operation over the extended industrial temperature range, -40°C to $+85^{\circ}\text{C}$.

Device Information

PART NUMBER	ON-CHIP V_{REF}	PACKAGE ⁽¹⁾
XTR115	2.5 V	D (SOIC, 8)
XTR116	4.096 V	

- (1) For all available packages, see the orderable addendum at the end of the data sheet.

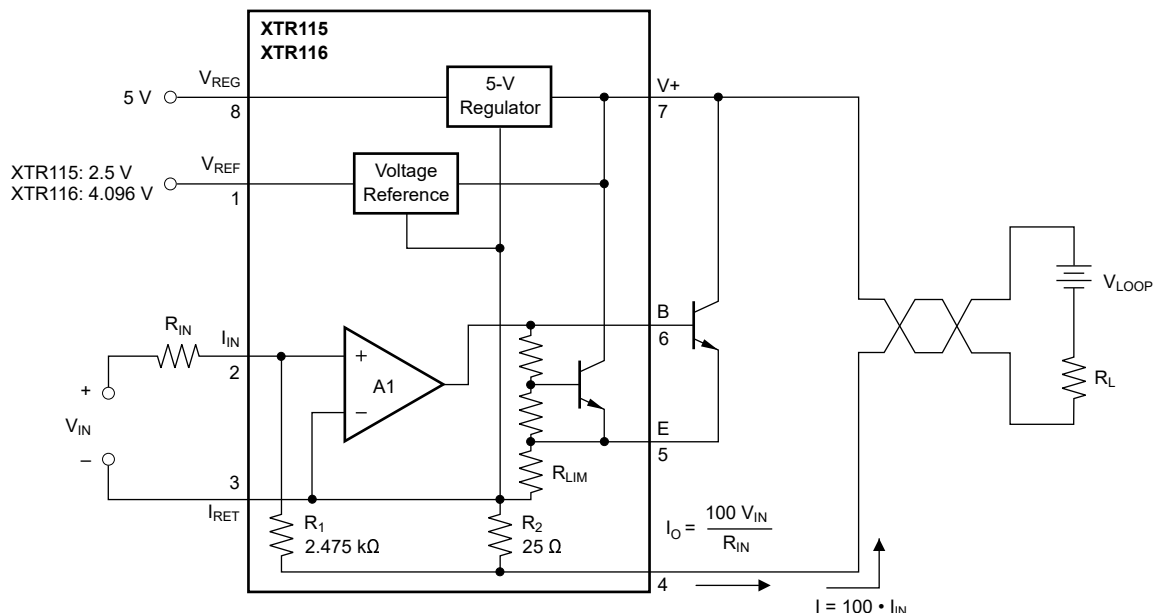

Typical Application



Table of Contents

1 Features	1	7.3 Feature Description.....	8
2 Applications	1	8 Application and Implementation	9
3 Description	1	8.1 Application Information.....	9
4 Revision History	2	9 Device and Documentation Support	13
5 Pin Configuration and Functions	3	9.1 Device Support.....	13
6 Specifications	4	9.2 Documentation Support.....	13
6.1 Absolute Maximum Ratings.....	4	9.3 Receiving Notification of Documentation Updates...	13
6.2 Recommended Operating Conditions.....	4	9.4 Support Resources.....	13
6.3 Thermal Information.....	4	9.5 Trademarks.....	13
6.4 Electrical Characteristics.....	5	9.6 Electrostatic Discharge Caution.....	13
6.5 Typical Characteristics.....	6	9.7 Glossary.....	13
7 Detailed Description	7	10 Mechanical, Packaging, and Orderable	
7.1 Overview.....	7	Information	13
7.2 Functional Block Diagram.....	7		

4 Revision History

NOTE: Page numbers for previous revisions may differ from page numbers in the current version.

Changes from Revision A (November 2003) to Revision B (March 2022)	Page
• Updated the numbering format for tables, figures, and cross-references throughout the document.....	1
• Added <i>Pin Functions</i> , <i>ESD Ratings</i> , <i>Thermal Information</i> , <i>Recommended Operating Conditions</i> , and <i>Electrical Characteristics</i> tables, and <i>Detailed Description</i> , <i>Overview</i> , <i>Functional Block Diagram</i> , <i>Feature Description</i> , <i>Application and Implementation</i> , <i>Device and Documentation Support</i> , and <i>Mechanical, Packaging, and Orderable Information</i> sections.....	1
• Added <i>Pin Functions</i> table.....	3
• Changed operating temperature minimum value from -55°C to -40°C in <i>Absolute Maximum Ratings</i>	4
• Deleted thermal resistance, θ_{JA} specification of 150°C/W from <i>Electrical Characteristics</i> ; added a <i>Thermal Information</i> table, with $R_{\theta\text{JA}} = 128.2^{\circ}\text{C/W}$ and other detailed thermal parameters.....	4
• Changed span error test condition from: $I_{\text{IN}} = 250\ \mu\text{A}$ to $25\ \text{mA}$ to: $I_{\text{OUT}} = 250\ \mu\text{A}$ to $25\ \text{mA}$ in <i>Electrical Characteristics</i>	5
• Changed V_{REF} voltage accuracy vs load typical value from $\pm 100\ \text{ppm/mA}$ to $\pm 200\ \text{ppm/mA}$ in <i>Electrical Characteristics</i>	5
• Changed bias current vs temperature typical value from $150\ \text{pA/}^{\circ}\text{C}$ to $300\ \text{pA/}^{\circ}\text{C}$ in <i>Electrical Characteristics</i>	5
• Changed <i>Basic Circuit Connections</i> application diagram.....	9
• Changed <i>External Transistor</i> applications information section to incorporate additional guidance regarding transistor power dissipation and thermal concerns.....	10
• Added <i>Circuit Stability</i> application information section.....	12

5 Pin Configuration and Functions

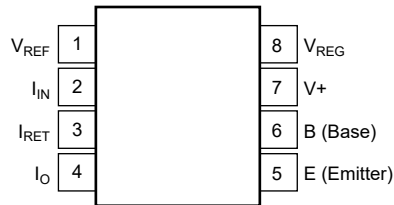

Figure 5-1. D Package, SOIC-8 (Top View)

Table 5-1. Pin Functions

PIN		TYPE	DESCRIPTION
NO.	NAME		
1	V _{REF}	Output	Reference voltage output (2.5 V for XTR115, 4.096 V for XTR116)
2	I _{IN}	Input	Current input pin
3	I _{RET}	Input	Local ground return pin for V _{REG} and V _{REF}
4	I _O	Output	Regulated 4-mA to 20-mA current-loop output
5	E (Emitter)	Input	Emitter connection for external transistor
6	B (Base)	Output	Base connection for external transistor
7	V+	Power	Loop power supply
8	V _{REG}	Output	5-V regulator voltage output

6 Specifications

6.1 Absolute Maximum Ratings

over operating free-air temperature range (unless otherwise noted)⁽¹⁾

		MIN	MAX	UNIT
V+	Power supply (referenced to I _O pin)		40	V
	Input voltage (referenced to I _{REF} pin)	0	V+	V
	Output current limit	Continuous		
	V _{REG} , short-circuit	Continuous		
	V _{REF} , short-circuit	Continuous		
T _A	Operating temperature	–40	125	°C
T _J	Junction temperature		165	°C
T _{stg}	Storage temperature	–55	125	°C
	Lead temperature (soldering, 10 s)		300	°C

- (1) Stresses above these ratings may cause permanent damage. Exposure to absolute maximum conditions for extended periods may degrade device reliability.

6.2 Recommended Operating Conditions

over operating free-air temperature range (unless otherwise noted)

		MIN	NOM	MAX	UNIT
V+	Power supply voltage	7.5	24	36	V
T _A	Specified temperature	–40		85	°C

6.3 Thermal Information

THERMAL METRIC ⁽¹⁾		XTR11x	UNIT
		D (SOIC)	
		8 PINS	
R _{θJA}	Junction-to-ambient thermal resistance	128.2	°C/W
R _{θJC(top)}	Junction-to-case (top) thermal resistance	68.2	°C/W
R _{θJB}	Junction-to-board thermal resistance	75.7	°C/W
ψ _{JT}	Junction-to-top characterization parameter	15.5	°C/W
ψ _{JB}	Junction-to-board characterization parameter	74.9	°C/W
R _{θJC(bot)}	Junction-to-case (bottom) thermal resistance	N/A	°C/W

- (1) For more information about traditional and new thermal metrics, see the [Semiconductor and IC package thermal metrics](#) application report.

6.4 Electrical Characteristics

at $T_A = 25^\circ\text{C}$, $V_+ = 24\text{ V}$, $R_{IN} = 20\text{ k}\Omega$, and TIP29C external transistor (unless otherwise noted)

PARAMETER		TEST CONDITIONS	XTR115U, XTR116U			XTR115UA, XTR116UA			UNIT
			MIN	TYP	MAX	MIN	TYP	MAX	
OUTPUT									
I_O	Output current equation		$I_O = I_{IN} \times 100$			$I_O = I_{IN} \times 100$			
	Output current, linear range		0.25		25	0.25		25	mA
I_{LIM}	Overscale limit			32			32		mA
I_{MIN}	Underscale limit	$I_{REG} = 0$, $I_{REF} = 0$		0.2	0.25		0.2	0.25	mA
SPAN									
S	Span (current gain)			100			100		A/A
	Error ⁽¹⁾	$I_{OUT} = 250\text{ mA to }25\text{ mA}$		± 0.05	± 0.2		± 0.05	± 0.4	%
	vs Temperature	$T_A = -40^\circ\text{C to }+85^\circ\text{C}$		± 3	± 20		± 3	± 20	ppm/ $^\circ\text{C}$
	Nonlinearity	$I_{IN} = 250\text{ mA to }25\text{ mA}$		± 0.003	± 0.01		± 0.003	± 0.02	%
INPUT									
V_{OS}	Offset voltage (op amp)	$I_{IN} = 40\text{ mA}$		± 100	± 250		± 100	± 500	μV
	vs Temperature	$T_A = -40^\circ\text{C to }+85^\circ\text{C}$		± 0.7	± 3		± 0.7	± 6	$\mu\text{V}/^\circ\text{C}$
	vs Supply voltage, V_+	$V_+ = 7.5\text{ V to }36\text{ V}$		± 0.1	± 2		± 0.1	± 2	$\mu\text{V}/\text{V}$
I_B	Bias current			-35			-35		nA
	vs Temperature			300			300		pA/ $^\circ\text{C}$
e_n	Noise: 0.1 Hz to 10 Hz			0.6			0.6		$\mu\text{Vp-p}$
DYNAMIC RESPONSE									
	Small signal bandwidth	$C_{LOOP} = 0$, $R_L = 0$		380			380		kHz
	Slew rate			3.2			3.2		mA/ μs
V_{REF}⁽²⁾									
	XTR115			2.5			2.5		V
	XTR116			4.096			4.096		V
	Voltage accuracy	$I_{REF} = 0$		± 0.05	± 0.25		± 0.05	± 0.5	%
	vs Temperature	$T_A = -40^\circ\text{C to }+85^\circ\text{C}$		± 20	± 35		± 20	± 75	ppm/ $^\circ\text{C}$
	vs Supply voltage, V_+	$V_+ = 7.5\text{ V to }36\text{ V}$		± 1	± 10		± 1	± 10	ppm/V
	vs Load	$I_{REF} = 0\text{ mA to }2.5\text{ mA}$		± 200			± 200		ppm/mA
	Noise	0.1 Hz to 10 Hz		10			10		$\mu\text{Vp-p}$
	Short-circuit current			16			16		mA
V_{REG}⁽²⁾									
	Voltage			5			5		V
	Voltage accuracy	$I_{REG} = 0$		± 0.05	± 0.1		± 0.05	± 0.1	V
	vs Temperature	$T_A = -40^\circ\text{C to }+85^\circ\text{C}$		± 0.1			± 0.1		mV/ $^\circ\text{C}$
	vs Supply voltage, V_+	$V_+ = 7.5\text{ V to }36\text{ V}$		1			1		mV/V
	vs Output current			See Typical Characteristics			See Typical Characteristics		
	Short-circuit current			12			12		mA
POWER SUPPLY, V_+									
	Quiescent current			200	250		200	250	μA
		$T_A = -40^\circ\text{C to }+85^\circ\text{C}$		240	300		240	300	μA

(1) Does not include initial error or TCR of R_{IN} .

(2) Voltage measured with respect to I_{RET} pin.

6.5 Typical Characteristics

At $T_A = 25^\circ\text{C}$, $V_+ = 24\text{ V}$, $R_{IN} = 20\text{ k}\Omega$, and TIP29C external transistor (unless otherwise noted)

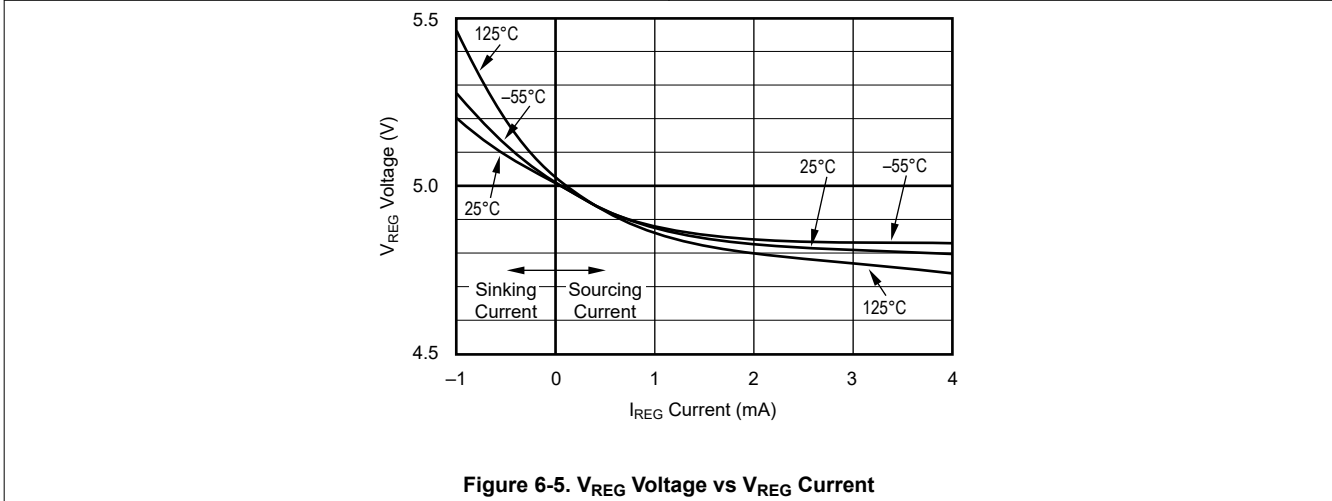
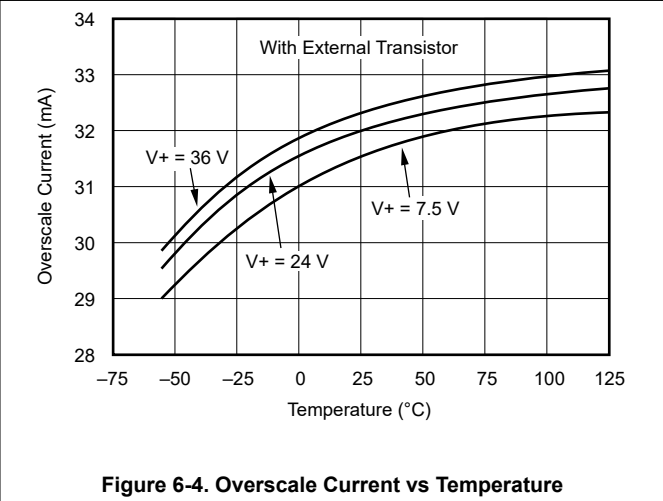
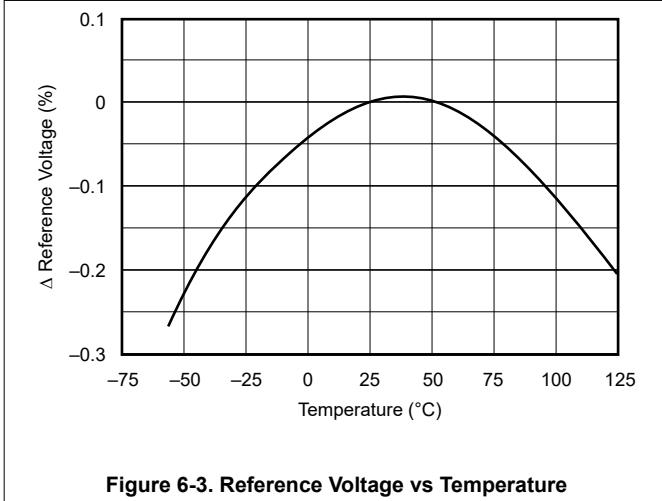
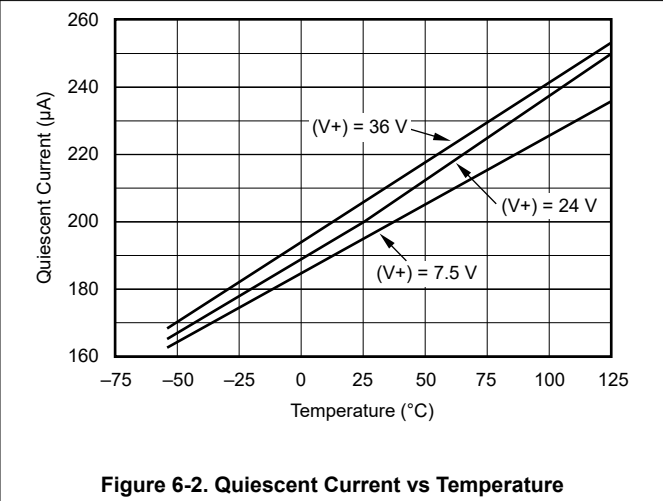
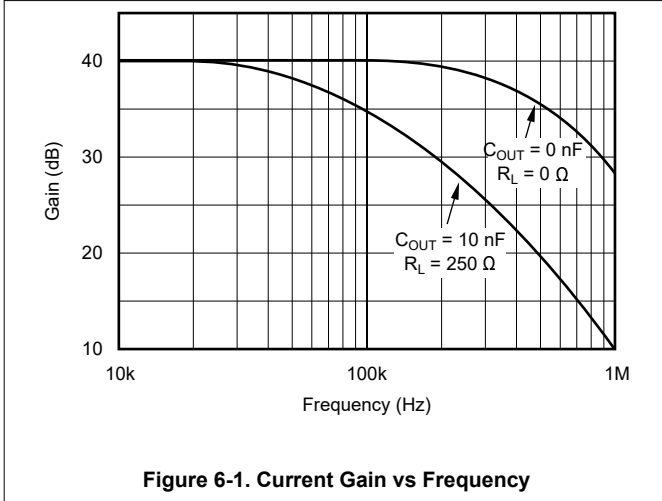

7 Detailed Description

7.1 Overview

The XTR115 and XTR116 are precision current output converters designed to transmit analog 4-mA-to-20-mA signals over an industry standard current loop. The regulator and reference voltages power a sensor, such as a bridge as shown in Figure 7-1. The sensor output, as a current signal I_{IN} , is gained up and transmitted over the loop to be read by a receiver.

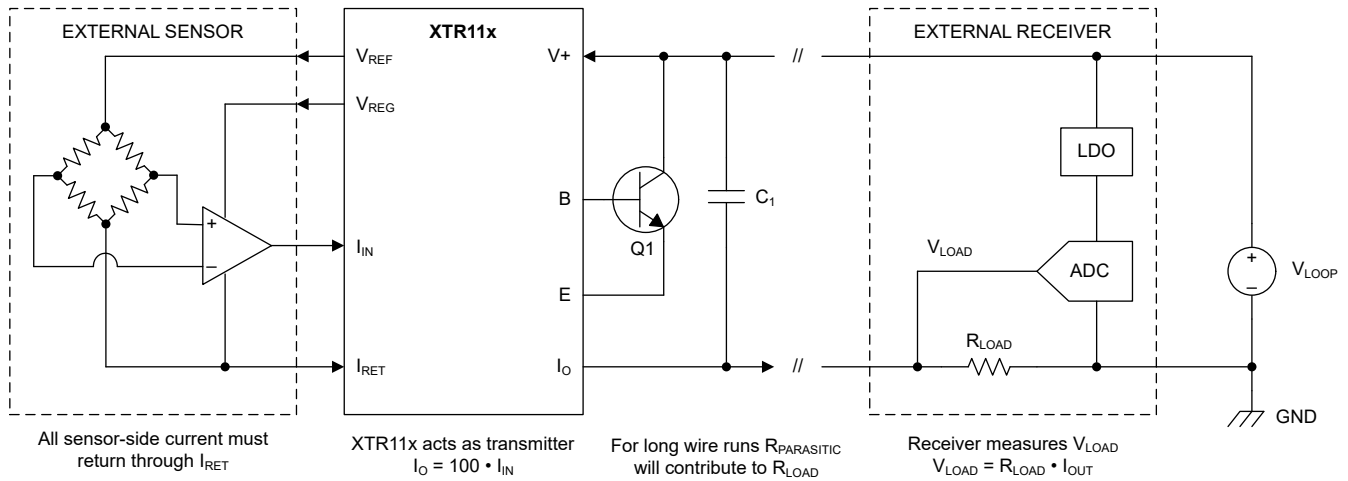
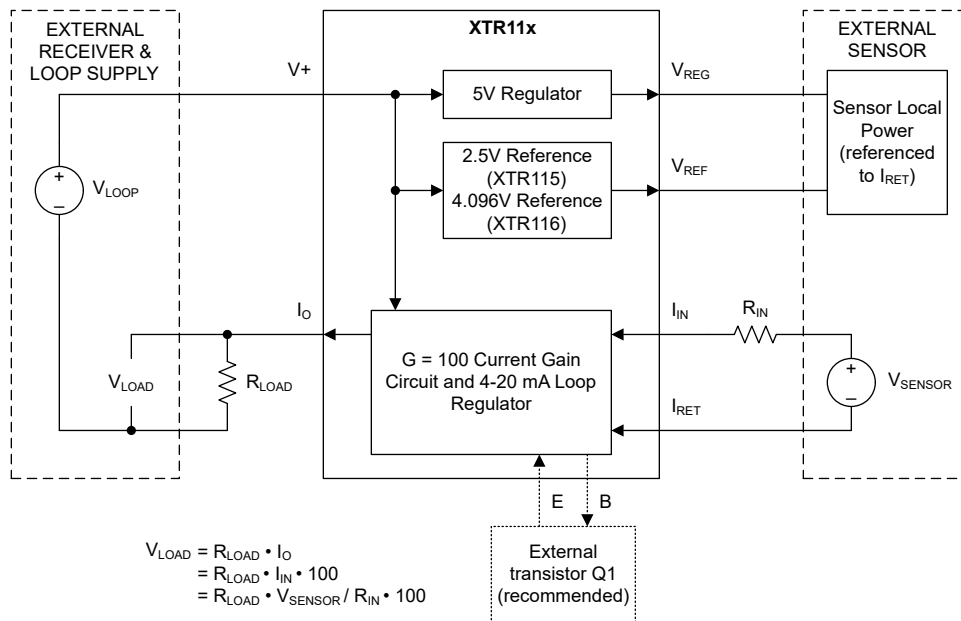

Figure 7-1. Typical Schematic

7.2 Functional Block Diagram



7.3 Feature Description

7.3.1 Reverse-Voltage Protection

The XTR11x low compliance voltage rating (7.5 V) permits the use of various voltage protection methods without compromising the operating range. Figure 7-2 shows a diode bridge circuit that allows normal operation even when the voltage connection lines are reversed. The bridge causes a two-diode drop (approximately 1.4 V) loss in loop supply voltage. This loss results in a compliance voltage of approximately 9 V—satisfactory for most applications. A diode can be inserted in series with the loop supply voltage and the V+ pin to protect against reverse output connection lines with only a 0.7-V loss in loop supply voltage.

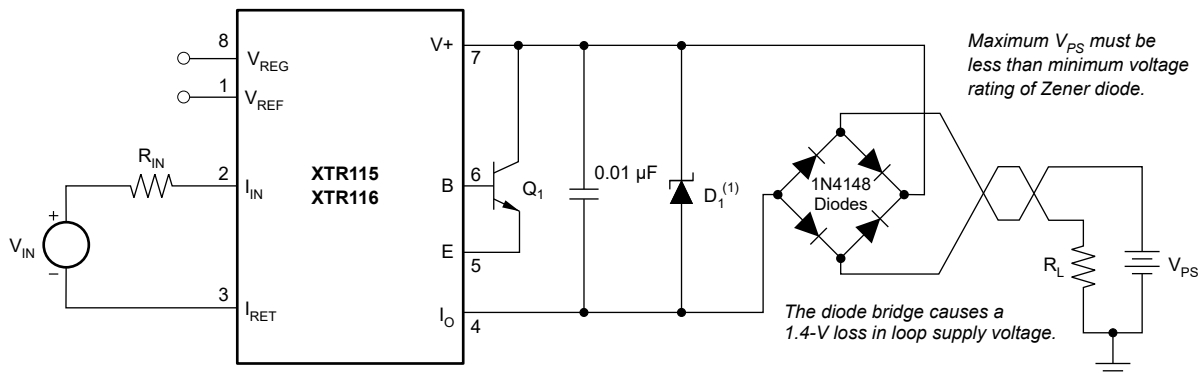

(1) Zener Diode 36 V: 1N4753A or Motorola P6KE39A. Use lower-voltage Zener diodes with loop power-supply voltages less than 30 V for increased protection; see Section 7.3.2.

Figure 7-2. Reverse Voltage Operation and Overvoltage Surge Protection

7.3.2 Overvoltage Surge Protection

Remote connections to current transmitters can sometimes be subjected to voltage surges. Best practice is to limit the maximum surge voltage applied to the XTR11x to as low as practical. Various Zener and surge clamping diodes are specially designed for this purpose. Select a clamp diode with as low a voltage rating as possible for best protection. For example, a 36-V protection diode provides proper transmitter operation at normal loop voltages, and also provides an appropriate level of protection against voltage surges. Characterization tests on several production lots showed no damage with loop supply voltages up to 65 V.

Most surge protection Zener diodes have a diode characteristic in the forward direction that conducts excessive current, possibly damaging receiving-side circuitry if the loop connections are reversed. If a surge protection diode is used, also use a series diode or diode bridge for protection against reversed connections.

8 Application and Implementation

Note

Information in the following applications sections is not part of the TI component specification, and TI does not warrant its accuracy or completeness. TI's customers are responsible for determining suitability of components for their purposes, as well as validating and testing their design implementation to confirm system functionality.

8.1 Application Information

The XTR115 and XTR116 are identical devices except for the reference voltage output, pin 1. This voltage is available for external circuitry and is not used internally. Further discussions that apply to both devices refer to the XTR11x.

Figure 8-1 shows basic circuit connections with representative simplified input circuitry. The XTR11x is a two-wire current transmitter. The device input signal (pin 2) controls the output current. A portion of this current flows into the V+ power supply, pin 7. The remaining current flows in Q₁. External input circuitry connected to the XTR11x can be powered from VREG or VREF. Current drawn from these terminals must be returned to IRET, pin 3. This IRET pin is a *local ground* for input circuitry driving the XTR11x.

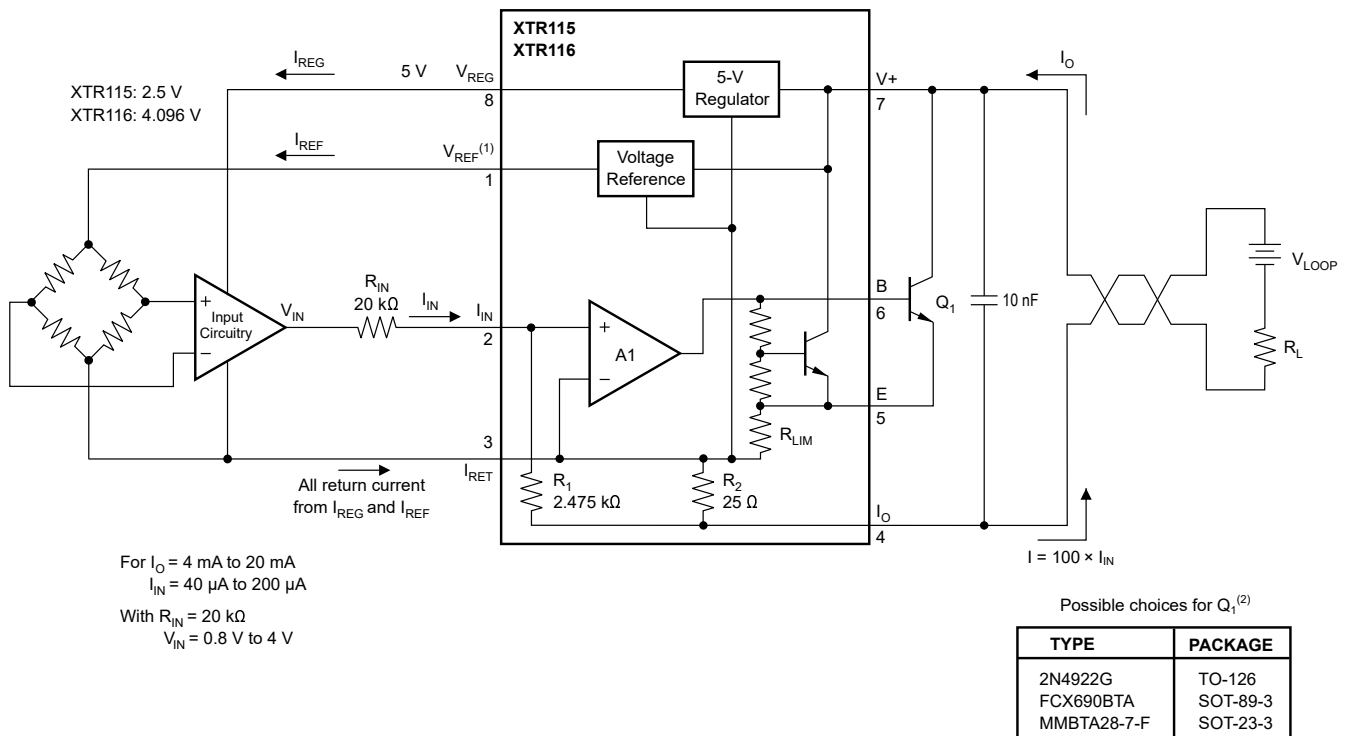

(1) Also see Figure 8-4.

(2) See Section 8.1.1.

Figure 8-1. Basic Circuit Connections

The XTR11x is a current-input device with a gain of 100. A current flowing into pin 2 produces $I_O = 100 \cdot I_{IN}$. The input voltage at the I_{IN} pin is zero (referred to the I_{RET} pin). A voltage input is created with an external input resistor, as shown. Common full-scale input voltages range from 1 V and upward. Full-scale inputs greater than 0.5 V are recommended to minimize the effect of offset voltage and drift of A1.

8.1.1 External Transistor

The external transistor, Q_1 , conducts the majority of the full-scale output current. Power dissipation in this transistor can approach 0.8 W with high loop voltage (40 V) and 20 mA of output current. The XTR11x is designed to use an external transistor to avoid on-chip, thermal-induced errors. Heat produced by Q_1 still causes ambient temperature changes that can affect the XTR11x. To minimize these effects, locate Q_1 away from sensitive analog circuitry, including the XTR11x. Mount Q_1 so that heat is conducted to the outside of the transducer housing and away from the XTR11x.

The XTR11x is designed to use virtually any NPN transistor with sufficient voltage, current, and power rating. Case style and thermal mounting considerations often influence the choice for any given application. Several possible choices are listed in Figure 8-1. A MOSFET transistor does not improve the accuracy of the XTR11x and is not recommended. Although the XTR11x can be used without an additional external transistor, this configuration is not always practical at higher loop voltages and currents because of self-heating concerns.

8.1.2 Minimum Scale Current

The quiescent current of the XTR11x (typically 200 μA) is the lower limit of the device output current. Zero input current ($I_{\text{IN}} = 0 \text{ A}$) produces an I_{O} equal to the quiescent current. Output current does not begin to increase until $I_{\text{IN}} > I_{\text{Q}} / 100$. Current drawn from V_{REF} or V_{REG} adds to this minimum output current. This means that more than 3.7 mA is available to power external circuitry while still allowing the output current to go below 4 mA.

8.1.3 Offsetting the Input

A low scale of 4 mA is produced by creating a 40- μA input current. This low-scale offset can be created with the proper value resistor from V_{REF} (as shown in Figure 8-2, or by generating offset in the input drive circuitry.

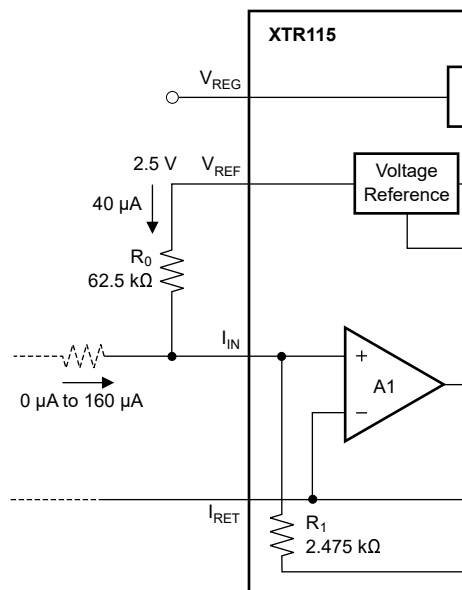

Figure 8-2. Creating Low-Scale Offset

8.1.4 Maximum Output Current

The XTR11x provide accurate, linear output up to 25 mA. Internal circuitry limits the output current to approximately 32 mA to protect the transmitter and loop power or measurement circuitry.

Extending the output current range of the XTR11x is possible by connecting an external resistor from pin 3 to pin 5 to change the current limit value.

CAUTION

All output current must flow through internal resistors; therefore, damage is possible with excessive current. Output currents greater than 45 mA can cause permanent damage.

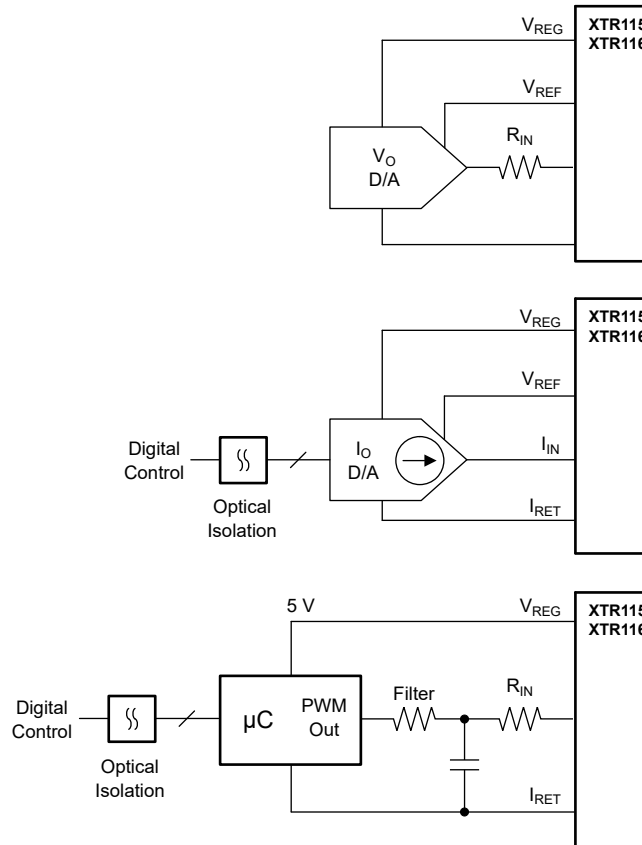

Figure 8-3. Digital Control Methods

8.1.5 Radio Frequency Interference

The long wire lengths of current loops invite radio frequency interference (RF). RF can be rectified by the input circuitry of the XTR11x or preceding circuitry. This RF generally appears as an unstable output current that varies with the position of loop supply or input wiring. Interference can also enter at the input pins. For integrated transmitter assemblies with short connection to the sensor, the interference more likely comes from the current-loop connections.

8.1.6 Circuit Stability

The 4-20 mA control-loop stability must be evaluated for any XTR11x design. A 10-nF decoupling capacitor between $V+$ and I_O is recommended for most applications. As this capacitance appears in parallel with the load resistance R_{LOAD} from a stability perspective, the capacitor and resistor form a filter corner that can limit the bandwidth of the system. Therefore, for HART applications, use a bypass capacitance of 2 nF to 3 nF instead.

For applications with EMI and EMC concerns, use a bypass capacitor with sufficiently low ESR to decouple any ripple voltage from the V_{LOOP} supply. Otherwise, the ripple voltage couples onto the 4-mA to 20-mA current source, and appears as noise across R_{LOAD} after the current-to-voltage conversion.

Additionally, stability concerns apply to the V_{REF} reference buffer when driving capacitive loads. Figure 8-4 shows that two filtering capacitors are required, one C_{HF} of 10 pF to 0.5 μ F and another C_{LF} of 2.2 μ F to 22 μ F. Either a series isolation resistance R_{ISO} or a snubber R_{COMP} is used, depending on application requirements.

If capacitive loading must be placed on the VREF pin, use one of the following compensation schemes to maintain stable operation. Values of capacitance must remain within the given ranges.

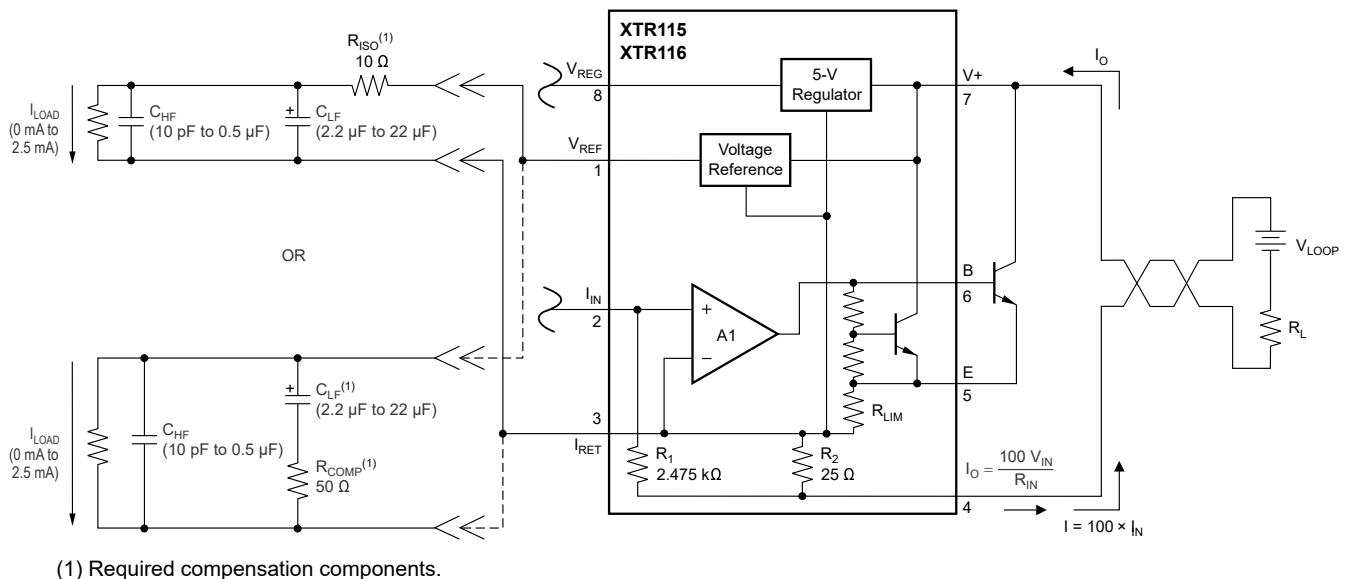

Figure 8-4. Stable Operation With Capacitive Load on V_{REF}

9 Device and Documentation Support

TI offers an extensive line of development tools. Tools and software to evaluate the performance of the device, generate code, and develop solutions are listed below.

9.1 Device Support

9.2 Documentation Support

9.2.1 Related Documentation

For related documentation see the following:

- Texas Instruments, [Special Function Amplifiers: TI Precision Labs introduction video on Current Loop Transmitters](#)
- Texas Instruments, [TIPD190 2-wire, 4-20mA Transmitter, EMC/EMI Tested Reference Design](#) with the XTR116

9.3 Receiving Notification of Documentation Updates

To receive notification of documentation updates, navigate to the device product folder on [ti.com](#). Click on *Subscribe to updates* to register and receive a weekly digest of any product information that has changed. For change details, review the revision history included in any revised document.

9.4 Support Resources

TI E2E™ [support forums](#) are an engineer's go-to source for fast, verified answers and design help — straight from the experts. Search existing answers or ask your own question to get the quick design help you need.

Linked content is provided "AS IS" by the respective contributors. They do not constitute TI specifications and do not necessarily reflect TI's views; see TI's [Terms of Use](#).

9.5 Trademarks

TI E2E™ is a trademark of Texas Instruments.
All trademarks are the property of their respective owners.

9.6 Electrostatic Discharge Caution



This integrated circuit can be damaged by ESD. Texas Instruments recommends that all integrated circuits be handled with appropriate precautions. Failure to observe proper handling and installation procedures can cause damage.

ESD damage can range from subtle performance degradation to complete device failure. Precision integrated circuits may be more susceptible to damage because very small parametric changes could cause the device not to meet its published specifications.

9.7 Glossary

[TI Glossary](#) This glossary lists and explains terms, acronyms, and definitions.

10 Mechanical, Packaging, and Orderable Information

The following pages include mechanical, packaging, and orderable information. This information is the most current data available for the designated devices. This data is subject to change without notice and revision of this document. For browser-based versions of this data sheet, refer to the left-hand navigation.

PACKAGING INFORMATION

Orderable Device	Status (1)	Package Type	Package Drawing	Pins	Package Qty	Eco Plan (2)	Lead finish/ Ball material (6)	MSL Peak Temp (3)	Op Temp (°C)	Device Marking (4/5)	Samples
XTR115U	OBSOLETE	SOIC	D	8		TBD	Call TI	Call TI	-40 to 85	XTR 115U	
XTR115U/2K5	ACTIVE	SOIC	D	8	2500	RoHS & Green	Call TI NIPDAU	Level-3-260C-168 HR	-40 to 85	XTR 115U	Samples
XTR115UA/2K5	ACTIVE	SOIC	D	8	2500	RoHS & Green	NIPDAU	Level-3-260C-168 HR	-40 to 85	XTR 115U A	Samples
XTR116U	OBSOLETE	SOIC	D	8		TBD	Call TI	Call TI	-40 to 85	XTR 116U	
XTR116U/2K5	ACTIVE	SOIC	D	8	2500	RoHS & Green	Call TI NIPDAU	Level-3-260C-168 HR	-40 to 85	XTR 116U	Samples
XTR116UA	OBSOLETE	SOIC	D	8		TBD	Call TI	Call TI	-40 to 85	XTR 116U A	
XTR116UA/2K5	ACTIVE	SOIC	D	8	2500	RoHS & Green	NIPDAU	Level-3-260C-168 HR	-40 to 85	XTR 116U A	Samples

(1) The marketing status values are defined as follows:

ACTIVE: Product device recommended for new designs.

LIFEBUY: TI has announced that the device will be discontinued, and a lifetime-buy period is in effect.

NRND: Not recommended for new designs. Device is in production to support existing customers, but TI does not recommend using this part in a new design.

PREVIEW: Device has been announced but is not in production. Samples may or may not be available.

OBSOLETE: TI has discontinued the production of the device.

(2) **RoHS:** TI defines "RoHS" to mean semiconductor products that are compliant with the current EU RoHS requirements for all 10 RoHS substances, including the requirement that RoHS substance do not exceed 0.1% by weight in homogeneous materials. Where designed to be soldered at high temperatures, "RoHS" products are suitable for use in specified lead-free processes. TI may reference these types of products as "Pb-Free".

RoHS Exempt: TI defines "RoHS Exempt" to mean products that contain lead but are compliant with EU RoHS pursuant to a specific EU RoHS exemption.

Green: TI defines "Green" to mean the content of Chlorine (Cl) and Bromine (Br) based flame retardants meet JS709B low halogen requirements of <=1000ppm threshold. Antimony trioxide based flame retardants must also meet the <=1000ppm threshold requirement.

(3) MSL, Peak Temp. - The Moisture Sensitivity Level rating according to the JEDEC industry standard classifications, and peak solder temperature.

(4) There may be additional marking, which relates to the logo, the lot trace code information, or the environmental category on the device.

⁽⁵⁾ Multiple Device Markings will be inside parentheses. Only one Device Marking contained in parentheses and separated by a "~" will appear on a device. If a line is indented then it is a continuation of the previous line and the two combined represent the entire Device Marking for that device.

⁽⁶⁾ Lead finish/Ball material - Orderable Devices may have multiple material finish options. Finish options are separated by a vertical ruled line. Lead finish/Ball material values may wrap to two lines if the finish value exceeds the maximum column width.

Important Information and Disclaimer:The information provided on this page represents TI's knowledge and belief as of the date that it is provided. TI bases its knowledge and belief on information provided by third parties, and makes no representation or warranty as to the accuracy of such information. Efforts are underway to better integrate information from third parties. TI has taken and continues to take reasonable steps to provide representative and accurate information but may not have conducted destructive testing or chemical analysis on incoming materials and chemicals. TI and TI suppliers consider certain information to be proprietary, and thus CAS numbers and other limited information may not be available for release.

In no event shall TI's liability arising out of such information exceed the total purchase price of the TI part(s) at issue in this document sold by TI to Customer on an annual basis.

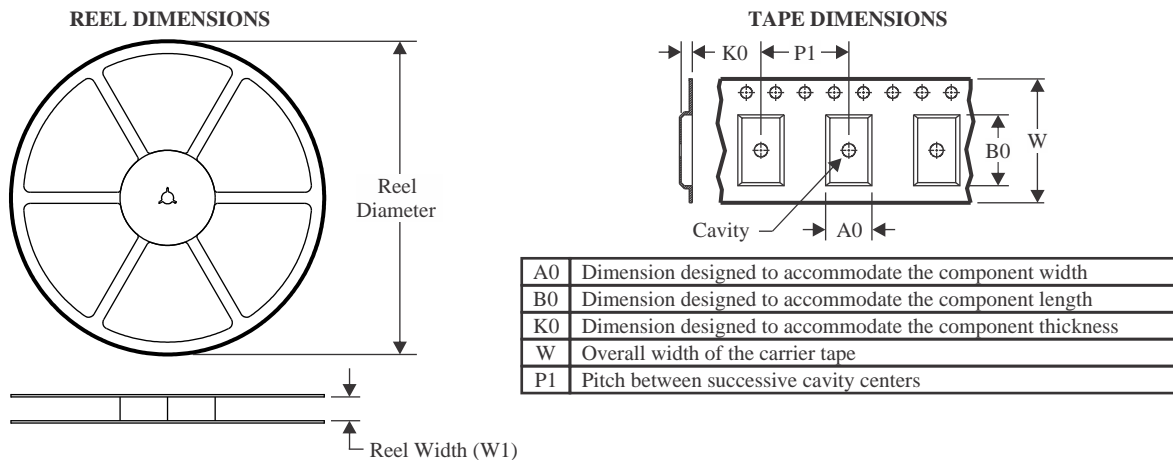
TAPE AND REEL INFORMATION

QUADRANT ASSIGNMENTS FOR PIN 1 ORIENTATION IN TAPE

*All dimensions are nominal

Device	Package Type	Package Drawing	Pins	SPQ	Reel Diameter (mm)	Reel Width W1 (mm)	A0 (mm)	B0 (mm)	K0 (mm)	P1 (mm)	W (mm)	Pin1 Quadrant
XTR115U/2K5	SOIC	D	8	2500	330.0	12.4	6.4	5.2	2.1	8.0	12.0	Q1
XTR115U/2K5	SOIC	D	8	2500	330.0	12.4	6.4	5.2	2.1	8.0	12.0	Q1
XTR115UA/2K5	SOIC	D	8	2500	330.0	12.4	6.4	5.2	2.1	8.0	12.0	Q1
XTR115UA/2K5	SOIC	D	8	2500	330.0	12.4	6.4	5.2	2.1	8.0	12.0	Q1
XTR116U/2K5	SOIC	D	8	2500	330.0	12.4	6.4	5.2	2.1	8.0	12.0	Q1
XTR116U/2K5	SOIC	D	8	2500	330.0	12.4	6.4	5.2	2.1	8.0	12.0	Q1
XTR116UA/2K5	SOIC	D	8	2500	330.0	12.4	6.4	5.2	2.1	8.0	12.0	Q1
XTR116UA/2K5	SOIC	D	8	2500	330.0	12.4	6.4	5.2	2.1	8.0	12.0	Q1

TAPE AND REEL BOX DIMENSIONS

*All dimensions are nominal

Device	Package Type	Package Drawing	Pins	SPQ	Length (mm)	Width (mm)	Height (mm)
XTR115U/2K5	SOIC	D	8	2500	356.0	356.0	35.0
XTR115U/2K5	SOIC	D	8	2500	356.0	356.0	35.0
XTR115UA/2K5	SOIC	D	8	2500	356.0	356.0	35.0
XTR115UA/2K5	SOIC	D	8	2500	356.0	356.0	35.0
XTR116U/2K5	SOIC	D	8	2500	353.0	353.0	32.0
XTR116U/2K5	SOIC	D	8	2500	356.0	356.0	35.0
XTR116UA/2K5	SOIC	D	8	2500	356.0	356.0	35.0
XTR116UA/2K5	SOIC	D	8	2500	353.0	353.0	32.0

TUBE

*All dimensions are nominal

Device	Package Name	Package Type	Pins	SPQ	L (mm)	W (mm)	T (μm)	B (mm)
XTR116U	D	SOIC	8	75	506.6	8	3940	4.32
XTR116UA	D	SOIC	8	75	506.6	8	3940	4.32



D0008A

PACKAGE OUTLINE

SOIC - 1.75 mm max height

SMALL OUTLINE INTEGRATED CIRCUIT



4214825/C 02/2019

NOTES:

1. Linear dimensions are in inches [millimeters]. Dimensions in parenthesis are for reference only. Controlling dimensions are in inches. Dimensioning and tolerancing per ASME Y14.5M.
2. This drawing is subject to change without notice.
3. This dimension does not include mold flash, protrusions, or gate burrs. Mold flash, protrusions, or gate burrs shall not exceed $.006$ [0.15] per side.
4. This dimension does not include interlead flash.
5. Reference JEDEC registration MS-012, variation AA.

EXAMPLE BOARD LAYOUT

D0008A

SOIC - 1.75 mm max height

SMALL OUTLINE INTEGRATED CIRCUIT



LAND PATTERN EXAMPLE
EXPOSED METAL SHOWN
SCALE:8X



SOLDER MASK DETAILS

4214825/C 02/2019

NOTES: (continued)

6. Publication IPC-7351 may have alternate designs.

7. Solder mask tolerances between and around signal pads can vary based on board fabrication site.

EXAMPLE STENCIL DESIGN

D0008A

SOIC - 1.75 mm max height

SMALL OUTLINE INTEGRATED CIRCUIT



SOLDER PASTE EXAMPLE
BASED ON .005 INCH [0.125 MM] THICK STENCIL
SCALE:8X

4214825/C 02/2019

NOTES: (continued)

8. Laser cutting apertures with trapezoidal walls and rounded corners may offer better paste release. IPC-7525 may have alternate design recommendations.
9. Board assembly site may have different recommendations for stencil design.

IMPORTANT NOTICE AND DISCLAIMER

TI PROVIDES TECHNICAL AND RELIABILITY DATA (INCLUDING DATA SHEETS), DESIGN RESOURCES (INCLUDING REFERENCE DESIGNS), APPLICATION OR OTHER DESIGN ADVICE, WEB TOOLS, SAFETY INFORMATION, AND OTHER RESOURCES "AS IS" AND WITH ALL FAULTS, AND DISCLAIMS ALL WARRANTIES, EXPRESS AND IMPLIED, INCLUDING WITHOUT LIMITATION ANY IMPLIED WARRANTIES OF MERCHANTABILITY, FITNESS FOR A PARTICULAR PURPOSE OR NON-INFRINGEMENT OF THIRD PARTY INTELLECTUAL PROPERTY RIGHTS.

These resources are intended for skilled developers designing with TI products. You are solely responsible for (1) selecting the appropriate TI products for your application, (2) designing, validating and testing your application, and (3) ensuring your application meets applicable standards, and any other safety, security, regulatory or other requirements.

These resources are subject to change without notice. TI grants you permission to use these resources only for development of an application that uses the TI products described in the resource. Other reproduction and display of these resources is prohibited. No license is granted to any other TI intellectual property right or to any third party intellectual property right. TI disclaims responsibility for, and you will fully indemnify TI and its representatives against, any claims, damages, costs, losses, and liabilities arising out of your use of these resources.

TI's products are provided subject to [TI's Terms of Sale](#) or other applicable terms available either on [ti.com](https://www.ti.com) or provided in conjunction with such TI products. TI's provision of these resources does not expand or otherwise alter TI's applicable warranties or warranty disclaimers for TI products.

TI objects to and rejects any additional or different terms you may have proposed.

Mailing Address: Texas Instruments, Post Office Box 655303, Dallas, Texas 75265
Copyright © 2024, Texas Instruments Incorporated