

# ADS1220 4-Channel, 2kSPS, Low-Power, 24-Bit ADC With Integrated PGA and Reference

## 1 Features

- Low current consumption:
  - As low as 120µA (typ) in duty-cycle mode
- Wide supply range: 2.3V to 5.5V
- Programmable gain: 1 to 128
- Programmable data rates: Up to 2kSPS
- Up to 20 Bits effective resolution
- Simultaneous 50Hz and 60Hz rejection at 20SPS with single-cycle settling digital filter
- Two differential or four single-ended inputs
- Dual-matched programmable current sources:
  - 10µA to 1.5mA
- Internal 2.048V reference: 5ppm/°C (typ) drift
- Internal 2% accurate oscillator
- Internal temperature sensor:
  - 0.5°C (typ) accuracy
- SPI-compatible interface (mode 1)

## 2 Applications

- Field transmitters:
  - Temperature, pressure, strain, flow
- PLC and DCS analog input modules
- Patient monitoring systems:
  - Body temperature, blood pressure
- Factory automation and process control

## 3 Description

The ADS1220 is a precision, 24-bit, analog-to-digital converter (ADC) that offers many integrated features to reduce system cost and component count in applications measuring small sensor signals. The device features two differential or four single-ended inputs through a flexible input multiplexer (MUX), a

low-noise, programmable gain amplifier (PGA), two programmable excitation current sources, a voltage reference, an oscillator, a low-side switch, and a precision temperature sensor.

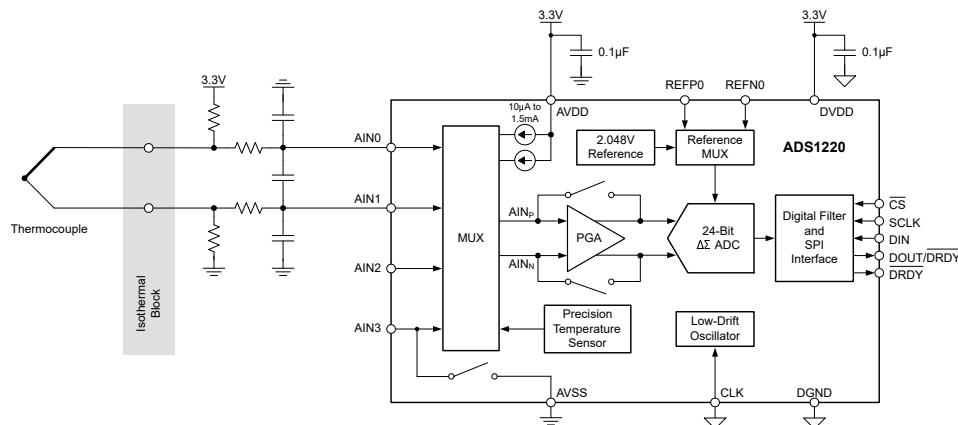
The device can perform conversions at data rates up to 2000 samples-per-second (SPS) with single-cycle settling. At 20SPS, the digital filter offers simultaneous 50Hz and 60Hz rejection for noisy industrial applications. The internal PGA offers gains up to 128. This PGA makes the ADS1220 designed for applications measuring small sensor signals, such as resistance temperature detectors (RTDs), thermocouples, thermistors, and resistive bridge sensors. The device supports measurements of pseudo- or fully-differential signals when using the PGA. Alternatively, the device can be configured to bypass the internal PGA while still providing high input impedance and gains up to 4, allowing for single-ended measurements.

Power consumption is as low as 120µA when operating in duty-cycle mode with the PGA disabled. The ADS1220 is offered in a leadless VQFN-16 or a TSSOP-16 package and is specified over a temperature range of –40°C to +125°C.

### Package Information

PART NUMBER	PACKAGE <sup>(1)</sup>	PACKAGE SIZE <sup>(2)</sup>
ADS1220	RVA (VQFN, 16)	3.5mm × 3.5mm
	PW (TSSOP, 16)	5.0mm × 6.4mm

- (1) For all available packages, see the orderable addendum at the end of the data sheet.
- (2) The package size (length × width) is a nominal value and includes pins, where applicable.



**K-Type Thermocouple Measurement**



## Table of Contents

<b>1 Features</b> .....	1	8.5.3 Commands.....	38
<b>2 Applications</b> .....	1	8.5.4 Reading Data.....	39
<b>3 Description</b> .....	1	8.5.5 Sending Commands.....	40
<b>4 Device Comparison Table</b> .....	3	8.5.6 Interfacing with Multiple Devices.....	41
<b>5 Pin Configuration and Functions</b> .....	4	8.6 Register Map.....	42
<b>6 Specifications</b> .....	5	8.6.1 Configuration Registers.....	42
6.1 Absolute Maximum Ratings.....	5	8.6.2 Register Descriptions.....	42
6.2 ESD Ratings.....	5	<b>9 Application and Implementation</b> .....	47
6.3 Recommended Operating Conditions.....	6	9.1 Application Information.....	47
6.4 Thermal Information.....	6	9.1.1 Serial Interface Connections.....	47
6.5 Electrical Characteristics.....	7	9.1.2 Analog Input Filtering.....	48
6.6 SPI Timing Requirements.....	9	9.1.3 External Reference and Ratiometric Measurements.....	49
6.7 SPI Switching Characteristics.....	9	9.1.4 Establishing a Proper Common-Mode Input Voltage.....	49
6.8 Timing Diagrams.....	9	9.1.5 Unused Inputs and Outputs.....	50
6.9 Typical Characteristics.....	10	9.1.6 Pseudo Code Example.....	51
<b>7 Parameter Measurement Information</b> .....	16	9.2 Typical Applications.....	52
7.1 Noise Performance.....	16	9.2.1 K-Type Thermocouple Measurement (– 200°C to +1250°C).....	52
<b>8 Detailed Description</b> .....	19	9.2.2 3-Wire RTD Measurement (–200°C to +850°C).....	55
8.1 Overview.....	19	9.2.3 Resistive Bridge Measurement.....	62
8.2 Functional Block Diagram.....	19	9.3 Power Supply Recommendations.....	64
8.3 Feature Description.....	20	9.3.1 Power-Supply Sequencing.....	64
8.3.1 Multiplexer.....	20	9.3.2 Power-Supply Ramp Rate.....	64
8.3.2 Low-Noise PGA.....	21	9.3.3 Power-Supply Decoupling.....	64
8.3.3 Voltage Reference.....	26	9.4 Layout.....	65
8.3.4 Clock Source.....	26	9.4.1 Layout Guidelines.....	65
8.3.5 Modulator.....	26	9.4.2 Layout Example.....	66
8.3.6 Digital Filter.....	27	<b>10 Device and Documentation Support</b> .....	67
8.3.7 Output Data Rate.....	30	10.1 Documentation Support.....	67
8.3.8 Excitation Current Sources.....	31	10.1.1 Related Documentation.....	67
8.3.9 Low-Side Power Switch.....	31	10.2 Receiving Notification of Documentation Updates..	67
8.3.10 Sensor Detection.....	31	10.3 Support Resources.....	67
8.3.11 System Monitor.....	32	10.4 Trademarks.....	67
8.3.12 Offset Calibration.....	32	10.5 Electrostatic Discharge Caution.....	67
8.3.13 Temperature Sensor.....	33	10.6 Glossary.....	67
8.4 Device Functional Modes.....	34	<b>11 Revision History</b> .....	67
8.4.1 Power-Up and Reset.....	34	<b>12 Mechanical, Packaging, and Orderable Information</b> .....	68
8.4.2 Conversion Modes.....	34		
8.4.3 Operating Modes.....	35		
8.5 Programming.....	36		
8.5.1 Serial Interface.....	36		
8.5.2 Data Format.....	37		

## 4 Device Comparison Table

DEVICE	RESOLUTION (Bits)	MAXIMUM GAIN	MAXIMUM DATA RATE (kSPS)	CHANNEL COUNT	INTERFACE	EXCITATION CURRENT SOURCES	TEMP. SENSOR	BIPOLAR SUPPLY	CLOCK	PACKAGE
ADS1119	16	4	1	4	I <sup>2</sup> C	No	No	No	Internal	WQFN-16
										TSSOP-16
ADS1219	24	4	1	4	I <sup>2</sup> C	No	No	No	Internal	WQFN-16
										TSSOP-16
ADS1120	16	128	2	4	SPI	Yes	Yes	Yes	Internal, External	WQFN-16
										TSSOP-16
ADS1220	24	128	2	4	SPI	Yes	Yes	Yes	Internal, External	WQFN-16
										TSSOP-16
ADS112C04	16	128	2	4	I <sup>2</sup> C	Yes	Yes	Yes	Internal	WQFN-16
										TSSOP-16
ADS122C04	24	128	2	4	I <sup>2</sup> C	Yes	Yes	Yes	Internal	WQFN-16
										TSSOP-16
ADS112U04	16	128	2	4	UART	Yes	Yes	Yes	Internal	WQFN-16
										TSSOP-16
ADS122U04	24	128	2	4	UART	Yes	Yes	Yes	Internal	WQFN-16
										TSSOP-16
ADS112S14	16	256	64	8	SPI	Yes	Yes	No	Internal, External	WQFN-16
										DBSGA-16
ADS122S14	24	256	64	8	SPI	Yes	Yes	No	Internal, External	WQFN-16
										DBSGA-16
ADS112C14	16	256	64	8	I <sup>2</sup> C	Yes	Yes	No	Internal, External	WQFN-16
										DBSGA-16
ADS122C14	24	256	64	8	I <sup>2</sup> C	Yes	Yes	No	Internal, External	WQFN-16
										DBSGA-16

## 5 Pin Configuration and Functions

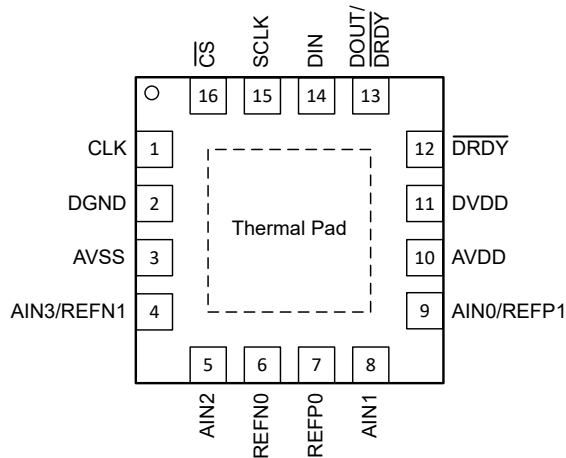


Figure 5-1. RVA Package, 16-Pin VQFN

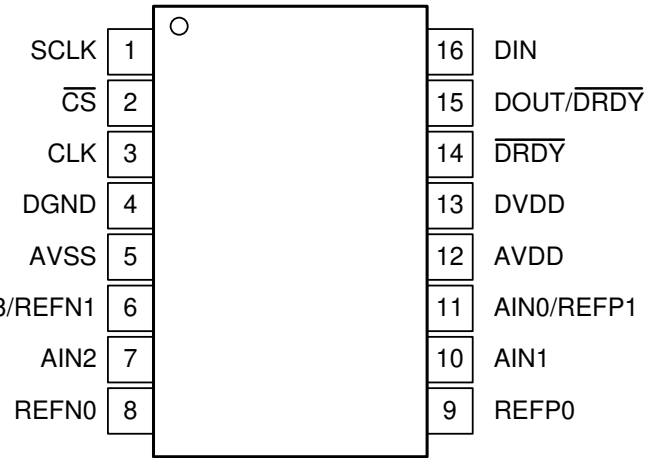


Figure 5-2. PW Package, 16-Pin TSSOP

Table 5-1. Pin Functions

NAME	PIN NO.		TYPE	DESCRIPTION <sup>(1)</sup>
	RVA	PW		
AIN0/REFP1	9	11	Analog input	Analog input 0, positive reference input 1
AIN1	8	10	Analog input	Analog input 1
AIN2	5	7	Analog input	Analog input 2
AIN3/REFN1	4	6	Analog input	Analog input 3, negative reference input 1. Internal low-side power switch connected between AIN3/REFN1 and AVSS.
AVDD	10	12	Analog supply	Positive analog power supply. Connect a 100nF (or larger) capacitor to AVSS.
AVSS	3	5	Analog supply	Negative analog power supply
CLK	1	3	Digital input	External clock source pin. Connect to DGND if not used.
CS	16	2	Digital input	Chip select; active low. Connect to DGND if not used.
DGND	2	4	Digital supply	Digital ground
DIN	14	16	Digital input	Serial data input
DOUT/DRDY	13	15	Digital output	Serial data output combined with data ready; active low
DRDY	12	14	Digital output	Data ready, active low. Leave unconnected or tie to DVDD using a weak pull-up resistor if not used.
DVDD	11	13	Digital supply	Positive digital power supply. Connect a 100nF (or larger) capacitor to DGND.
REFNO	6	8	Analog input	Negative reference input 0
REFP0	7	9	Analog input	Positive reference input 0
SCLK	15	1	Digital input	Serial clock input
Thermal pad	Pad	—	—	Thermal power pad. Do not connect or only connect to AVSS.

(1) See the [Unused Inputs and Outputs](#) section for unused pin connections.

## 6 Specifications

### 6.1 Absolute Maximum Ratings

over operating ambient temperature range (unless otherwise noted) <sup>(1)</sup>

		MIN	MAX	UNIT
Power-supply voltage	AVDD to AVSS	-0.3	7	V
	DVDD to DGND	-0.3	7	V
	AVSS to DGND	-2.8	0.3	V
Analog input voltage	AIN0/REFP1, AIN1, AIN2, AIN3/REFN1, REFP0, REFN0	AVSS - 0.3	AVDD + 0.3	V
Digital input voltage	$\overline{CS}$ , SCLK, DIN, DOUT/ $\overline{DRDY}$ , $\overline{DRDY}$ , CLK	DGND - 0.3	DVDD + 0.3	V
Input current	Continuous, any pin except power supply pins	-10	10	mA
Temperature	Junction, T <sub>J</sub>	-40	150	°C
	Storage, T <sub>stg</sub>	-60	150	°C

- (1) Operation outside the *Absolute Maximum Ratings* may cause permanent device damage. *Absolute Maximum Ratings* do not imply functional operation of the device at these or any other conditions beyond those listed under *Recommended Operating Conditions*. If used outside the *Recommended Operating Conditions* but within the *Absolute Maximum Ratings*, the device may not be fully functional, and this may affect device reliability, functionality, performance, and shorten the device lifetime.

### 6.2 ESD Ratings

			VALUE	UNIT
V <sub>(ESD)</sub>	Electrostatic discharge	Human-body model (HBM), per ANSI/ESDA/JEDEC JS-001 <sup>(1)</sup>	±2000	V
		Charged-device model (CDM), per JEDEC specification JESD22C101 <sup>(2)</sup>	±500	

- (1) JEDEC document JEP155 states that 500V HBM allows safe manufacturing with a standard ESD control process.  
 (2) JEDEC document JEP157 states that 250V CDM allows safe manufacturing with a standard ESD control process.

### 6.3 Recommended Operating Conditions

over operating ambient temperature range (unless otherwise noted)

			MIN	NOM	MAX	UNIT
<b>POWER SUPPLY</b>						
	Unipolar analog power supply	AVDD to AVSS	2.3		5.5	V
		AVSS to DGND	-0.1	0	0.1	
	Bipolar analog power supply	AVDD to DGND	2.3	2.5	2.75	V
		AVSS to DGND	-2.75	-2.5	-2.3	
	Digital power supply	DVDD to DGND	2.3		5.5	V
<b>ANALOG INPUTS<sup>(1)</sup></b>						
V <sub>IN</sub>	Differential input voltage	$V_{IN} = V_{AINP} - V_{AINN}$ <sup>(2)</sup>	$-V_{REF} / \text{Gain}$		$V_{REF} / \text{Gain}$	V
V <sub>AINx</sub>	Absolute input voltage	PGA disabled, gain = 1 to 4	AVSS - 0.1		AVDD + 0.1	V
		PGA enabled, gain = 1 to 128	See the <a href="#">Low-Noise PGA</a> section			
V <sub>CM</sub>	Common-mode input voltage	PGA disabled, gain = 1 to 4	AVSS - 0.1		AVDD + 0.1	V
		PGA enabled, gain = 1 to 128	See the <a href="#">Low-Noise PGA</a> section			
<b>VOLTAGE REFERENCE INPUTS<sup>(3)</sup></b>						
V <sub>REF</sub>	Differential reference input voltage	$V_{REF} = V_{REFPx} - V_{REFNx}$	0.75	2.5	AVDD - AVSS	V
V <sub>REFNx</sub>	Absolute negative reference voltage		AVSS - 0.1		$V_{REFPx} - 0.75$	V
V <sub>REFPx</sub>	Absolute positive reference voltage		$V_{REFNx} + 0.75$		AVDD + 0.1	V
<b>EXTERNAL CLOCK SOURCE</b>						
f <sub>CLK</sub>	External clock frequency		0.5	4.096	4.5	MHz
	Duty cycle		40%		60%	
<b>DIGITAL INPUTS</b>						
	Input voltage		DGND		DVDD	V
<b>TEMPERATURE RANGE</b>						
T <sub>A</sub>	Operating ambient temperature		-40		125	°C

- (1) AIN<sub>P</sub> and AIN<sub>N</sub> denote the positive and negative inputs of the PGA. AIN<sub>x</sub> denotes one of the four available analog inputs. *PGA disabled* means the low-noise PGA is powered down and bypassed. Gains of 1, 2, and 4 are still possible in this case. See the [Bypassing the PGA](#) section for more information.
- (2) Excluding the effects of offset and gain error. Limited to  $\pm[(AVDD - AVSS) - 0.4V] / \text{Gain}$ , when the PGA is enabled.
- (3) REFP<sub>x</sub> and REFN<sub>x</sub> denote one of the two available differential reference input pairs.

### 6.4 Thermal Information

THERMAL METRIC <sup>(1)</sup>		ADS1220		UNIT
		VQFN (RVA)	TSSOP (PW)	
		16 PINS	16 PINS	
R <sub>θJA</sub>	Junction-to-ambient thermal resistance	43.4	99.5	°C/W
R <sub>θJC(top)</sub>	Junction-to-case (top) thermal resistance	47.3	35.2	°C/W
R <sub>θJB</sub>	Junction-to-board thermal resistance	18.4	44.3	°C/W
ψ <sub>JT</sub>	Junction-to-top characterization parameter	0.6	2.4	°C/W
ψ <sub>JB</sub>	Junction-to-board characterization parameter	18.4	43.8	°C/W
R <sub>θJC(bot)</sub>	Junction-to-case (bottom) thermal resistance	2.0	n/a	°C/W

- (1) For more information about traditional and new thermal metrics, see the [Semiconductor and IC Package Thermal Metrics](#) application note.

## 6.5 Electrical Characteristics

Minimum and maximum specifications apply from  $T_A = -40^\circ\text{C}$  to  $+125^\circ\text{C}$ . Typical specifications are at  $T_A = 25^\circ\text{C}$ . All specifications are at  $AVDD = 3.3\text{V}$ ,  $AVSS = 0\text{V}$ ,  $DVDD = 3.3\text{V}$ , PGA enabled,  $DR = 20\text{SPS}$ , and external  $V_{REF} = 2.5\text{V}$  (unless otherwise noted).

PARAMETER	TEST CONDITIONS	MIN	TYP	MAX	UNIT	
<b>ANALOG INPUTS</b>						
	Absolute input current	See the <a href="#">Typical Characteristics</a>				
	Differential input current	See the <a href="#">Typical Characteristics</a>				
<b>SYSTEM PERFORMANCE</b>						
	Resolution (no missing codes)	24			Bits	
DR	Data rate	Normal mode	20, 45, 90, 175, 330, 600, 1000		SPS	
		Duty-cycle mode	5, 11.25, 22.5, 44, 82.5, 150, 250			
		Turbo mode	40, 90, 180, 350, 660, 1200, 2000			
	Noise (input-referred)	See the <a href="#">Noise Performance</a> section				
INL	Integral nonlinearity	Gain = 1 to 128, $V_{CM} = 0.5 AVDD$ , best fit <sup>(1)</sup>	-15	±6	15 ppm <sub>FSR</sub>	
$V_{IO}$	Input offset voltage	PGA disabled, gain = 1 to 4, differential inputs	±4		µV	
		Gain = 1, differential inputs, $T_A = 25^\circ\text{C}$	-30	±4		30
		Gain = 2 to 128, differential inputs	±4			
	Offset drift	PGA disabled, gain = 1 to 4	0.25		µV/°C	
		Gain = 1 to 128, $T_A = -40^\circ\text{C}$ to $+85^\circ\text{C}$ <sup>(1)</sup>	0.08			0.3
		Gain = 1 to 128	0.25			
	Offset match	Match between any two inputs	±20		µV	
	Gain error	PGA disabled, gain = 1 to 4	±0.015%			
		Gain = 1 to 128, $T_A = 25^\circ\text{C}$	-0.1%	±0.015%		0.1%
	Gain drift	PGA disabled, gain = 1 to 4	1		ppm/°C	
		Gain = 1 to 128 <sup>(1)</sup>	1			4
NMRR	Normal-mode rejection ratio <sup>(1)</sup>	50Hz ±3%, DR = 20SPS, external CLK, 50/60 bit = 10b	105		dB	
		60Hz ±3%, DR = 20SPS, external CLK, 50/60 bit = 11b	105			
		50Hz or 60Hz ±3%, DR = 20SPS, external CLK, 50/60 bit = 01b	90			
CMRR	Common-mode rejection ratio	At dc, gain = 1	90	105		dB
		$f_{CM} = 50\text{Hz}$ , DR = 2000SPS <sup>(1)</sup>	95	115		
		$f_{CM} = 60\text{Hz}$ , DR = 2000SPS <sup>(1)</sup>	95	115		
PSRR	Power-supply rejection ratio	AVDD at dc, $V_{CM} = 0.5 AVDD$ , gain = 1	80	105		dB
		DVDD at dc, $V_{CM} = 0.5 AVDD$ , gain = 1 <sup>(1)</sup>	100	115		
<b>INTERNAL VOLTAGE REFERENCE</b>						
	Initial accuracy	$T_A = 25^\circ\text{C}$	2.045	2.048	2.051 V	
	Reference drift <sup>(1)</sup>		5		30 ppm/°C	
	Long-term drift	1000 hours	110		ppm	
<b>VOLTAGE REFERENCE INPUTS</b>						
	Reference input current	REFP0 = $V_{REF}$ , REFN0 = AVSS	±10		nA	
<b>INTERNAL OSCILLATOR</b>						
	Internal oscillator accuracy	Normal mode	-2%	±1%	2%	
<b>EXCITATION CURRENT SOURCES (IDACs)</b>						
	Current settings		10, 50, 100, 250, 500, 1000, 1500		µA	
	Compliance voltage	All current settings	AVDD - 0.9		V	
	Accuracy	All current settings, each IDAC	-6%	±1%	6%	
	Current match	Between IDACs (not valid for 10µA setting)	±0.3%			
	Temperature drift	Each IDAC (not valid for 10µA setting)	50		ppm/°C	
	Temperature drift matching	Between IDACs (not valid for 10µA setting)	10		ppm/°C	

Minimum and maximum specifications apply from  $T_A = -40^{\circ}\text{C}$  to  $+125^{\circ}\text{C}$ . Typical specifications are at  $T_A = 25^{\circ}\text{C}$ . All specifications are at  $AVDD = 3.3\text{V}$ ,  $AVSS = 0\text{V}$ ,  $DVDD = 3.3\text{V}$ , PGA enabled,  $DR = 20\text{SPS}$ , and external  $V_{REF} = 2.5\text{V}$  (unless otherwise noted).

PARAMETER		TEST CONDITIONS	MIN	TYP	MAX	UNIT
<b>TEMPERATURE SENSOR</b>						
	Conversion resolution			14		Bits
	Temperature resolution			0.03125		$^{\circ}\text{C}$
	Accuracy	$T_A = 0^{\circ}\text{C}$ to $+75^{\circ}\text{C}$	-0.5	$\pm 0.25$	0.5	$^{\circ}\text{C}$
		$T_A = -40^{\circ}\text{C}$ to $+125^{\circ}\text{C}$	-1	$\pm 0.5$	1	
	Accuracy vs analog supply voltage			0.0625	0.25	$^{\circ}\text{C}/\text{V}$
<b>LOW-SIDE POWER SWITCH</b>						
$R_{ON}$	On-resistance			3.5	5.5	$\Omega$
	Current through switch				30	mA
<b>DIGITAL INPUTS/OUTPUTS</b>						
$V_{IH}$	High-level input voltage		0.7 DVDD		DVDD	V
$V_{IL}$	Low-level input voltage		DGND		0.3 DVDD	V
$V_{OH}$	High-level output voltage	$I_{OH} = 3\text{mA}$	0.8 DVDD			V
$V_{OL}$	Low-level output voltage	$I_{OL} = 3\text{mA}$			0.2 DVDD	V
$I_H$	Input leakage, high	$V_{IH} = 5.5\text{V}$	-10		10	$\mu\text{A}$
$I_L$	Input leakage, low	$V_{IL} = \text{DGND}$	-10		10	$\mu\text{A}$
<b>POWER SUPPLY</b>						
$I_{AVDD}$	Analog supply current <sup>(2)</sup>	Power-down mode		0.1	3	$\mu\text{A}$
		Duty-cycle mode, PGA disabled		65		
		Duty-cycle mode, gain = 1 to 16		95		
		Duty-cycle mode, gain = 32		115		
		Duty-cycle mode, gain = 64, 128		135		
		Normal mode, PGA disabled		240		
		Normal mode, gain = 1 to 16		340	490	
		Normal mode, gain = 32		425		
		Normal mode, gain = 64, 128		510		
		Turbo mode, PGA disabled		360		
		Turbo mode, gain = 1 to 16		540		
		Turbo mode, gain = 32		715		
Turbo mode, gain = 64, 128		890				
$I_{DVDD}$	Digital supply current <sup>(2)</sup>	Power-down mode		0.3	5	$\mu\text{A}$
		Duty-cycle mode		55		
		Normal mode		75	110	
		Turbo mode		95		
$P_D$	Power dissipation <sup>(2)</sup>	Duty-cycle mode, PGA disabled		0.4		mW
		Normal mode, gain = 1 to 16		1.4		
		Turbo mode, gain = 1 to 16		2.1		

(1) Minimum and maximum values are verified by design and characterization data.

(2) Internal voltage reference selected, internal oscillator enabled, IDACs turned off, and continuous conversion mode. Analog supply current increases by  $70\mu\text{A}$ , (typ) normal mode, turbo mode when selecting an external reference. Analog supply current increases by  $190\mu\text{A}$  (typ) when enabling the IDACs (excludes the actual IDAC current).

## 6.6 SPI Timing Requirements

over operating ambient temperature range and DVDD = 2.3V to 5.5V (unless otherwise noted)

		MIN	MAX	UNIT
$t_{d(CSSC)}$	Delay time, $\overline{CS}$ falling edge to first SCLK rising edge <sup>(2)</sup>	50		ns
$t_{d(SCCS)}$	Delay time, final SCLK falling edge to $\overline{CS}$ rising edge	25		ns
$t_{w(CSH)}$	Pulse duration, $\overline{CS}$ high	50		ns
$t_c(SC)$	SCLK period	150		ns
$t_{w(SCH)}$	Pulse duration, SCLK high	60		ns
$t_{w(SCL)}$	Pulse duration, SCLK low	60		ns
$t_{su(DI)}$	Setup time, DIN valid before SCLK falling edge	50		ns
$t_h(DI)$	Hold time, DIN valid after SCLK falling edge	25		ns
	SPI timeout <sup>(1)</sup>	Normal mode, duty-cycle mode	14000	$t_{MOD}$
		Turbo mode	28000	

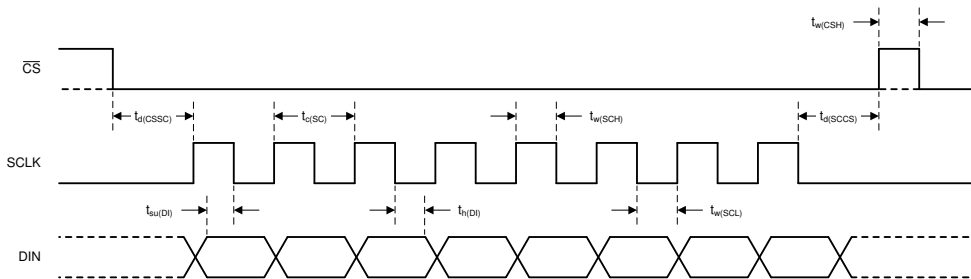
- (1) See the *SPI Timeout* section for more information.  
 $t_{MOD} = 1 / f_{MOD}$ . Modulator frequency  $f_{MOD} = 256\text{kHz}$  (normal mode, duty-cycle mode) and  $512\text{kHz}$  (turbo mode), when using the internal oscillator or an external 4.096MHz clock.
- (2)  $\overline{CS}$  can be tied low permanently in case the serial bus is not shared with any other device.

## 6.7 SPI Switching Characteristics

over operating ambient temperature range, DVDD = 2.3V to 5.5V (unless otherwise noted)

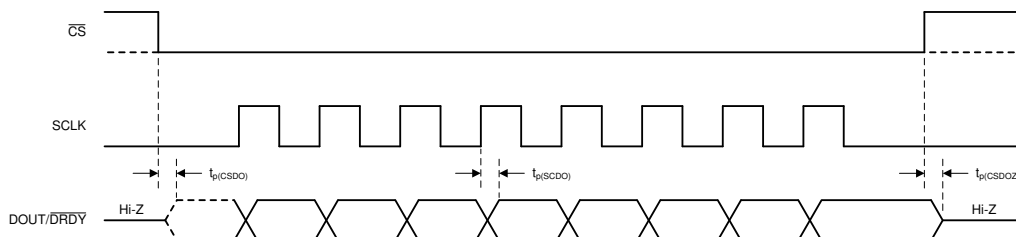
PARAMETER	TEST CONDITIONS	MIN	TYP	MAX	UNIT
$t_{p(CSDO)}$	Propagation delay time, $\overline{CS}$ falling edge to DOUT driven			50	ns
$t_{p(SCDO)}$	Propagation delay time, SCLK rising edge to valid new DOUT	0		50	ns
$t_{p(CSDOZ)}$	Propagation delay time, $\overline{CS}$ rising edge to DOUT high impedance			50	ns

## 6.8 Timing Diagrams



Single-byte communication is shown. Actual communication can be multiple bytes.

Figure 6-1. Serial Interface Timing Requirements



Single-byte communication is shown. Actual communication can be multiple bytes.

Figure 6-2. Serial Interface Switching Characteristics

## 6.9 Typical Characteristics

at  $T_A = 25^\circ\text{C}$ ,  $AVDD = 3.3\text{V}$ ,  $AVSS = 0\text{V}$ , and PGA enabled using external  $V_{REF} = 2.5\text{V}$  (unless otherwise noted).

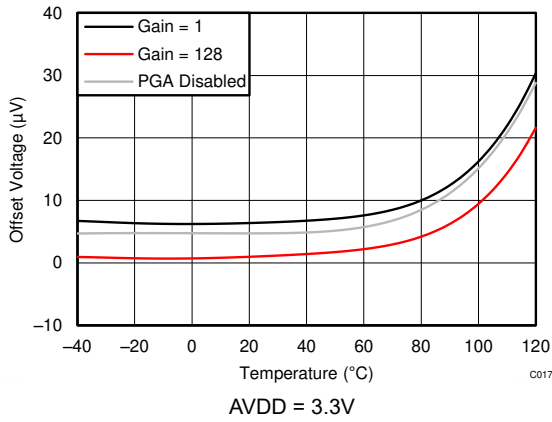


Figure 6-3. Input-Referred Offset Voltage vs Temperature

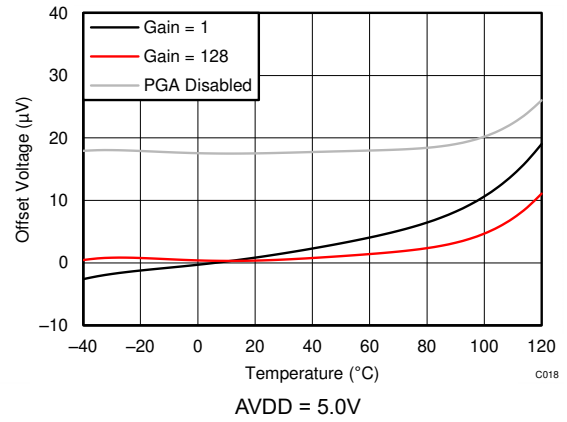


Figure 6-4. Input-Referred Offset Voltage vs Temperature

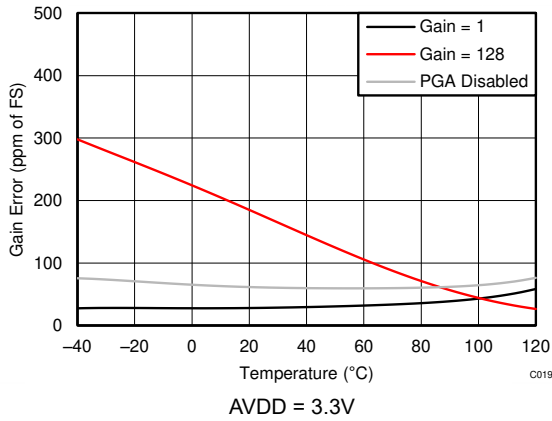


Figure 6-5. Gain Error vs Temperature

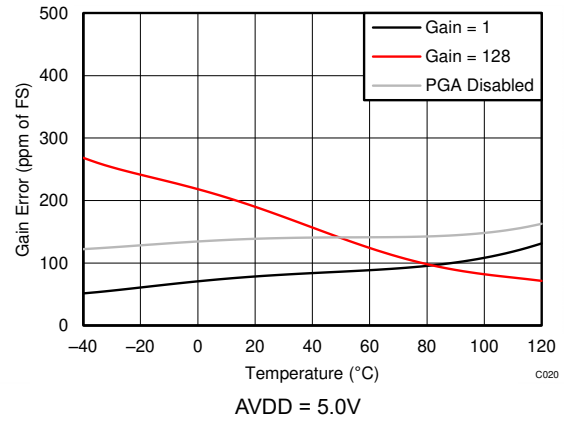


Figure 6-6. Gain Error vs Temperature

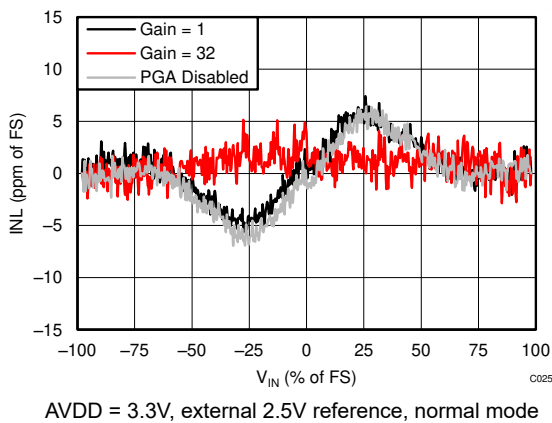


Figure 6-7. Integral Nonlinearity vs Differential Input Signal

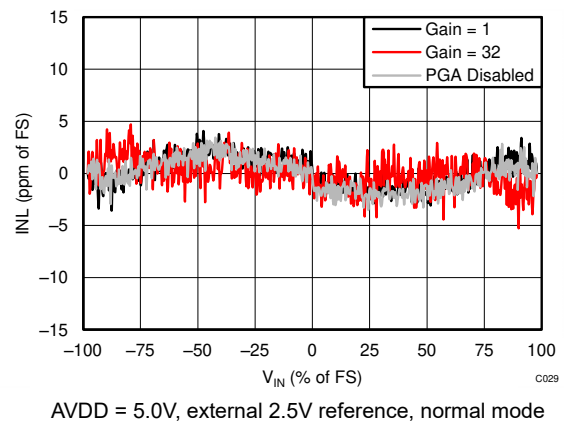
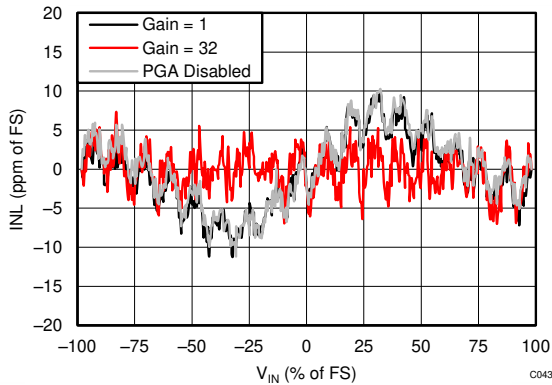


Figure 6-8. Integral Nonlinearity vs Differential Input Signal

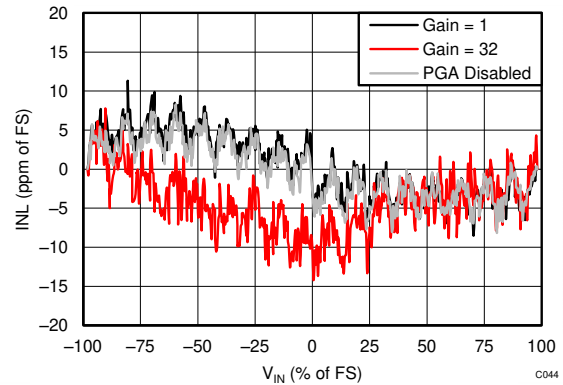
### 6.9 Typical Characteristics (continued)

at  $T_A = 25^\circ\text{C}$ ,  $AVDD = 3.3\text{V}$ ,  $AVSS = 0\text{V}$ , and PGA enabled using external  $V_{REF} = 2.5\text{V}$  (unless otherwise noted).



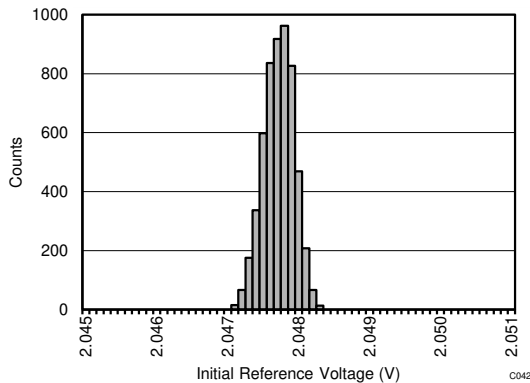
AVDD = 3.3V, internal reference, normal mode

**Figure 6-9. Integral Nonlinearity vs Differential Input Signal**



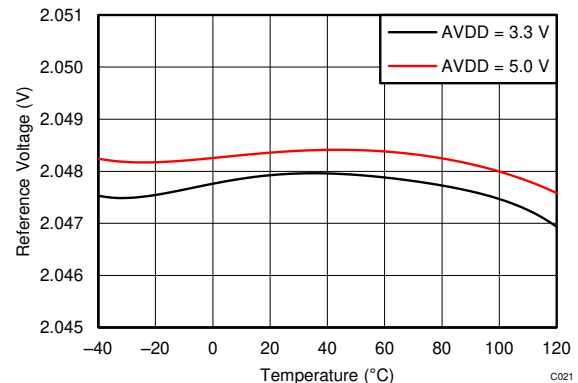
AVDD = 5.0V, internal reference, normal mode

**Figure 6-10. Integral Nonlinearity vs Differential Input Signal**

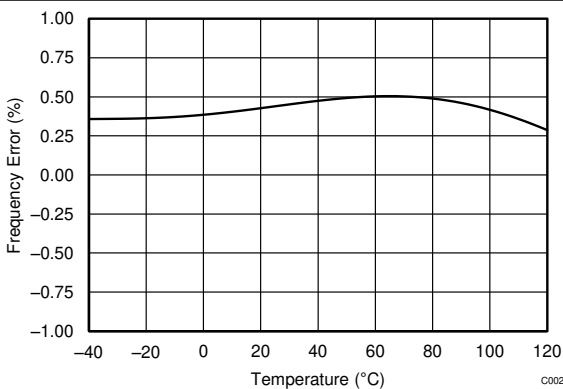


$T_A = 25^\circ\text{C}$ , data from 5490 devices

**Figure 6-11. Internal Reference Voltage Histogram**

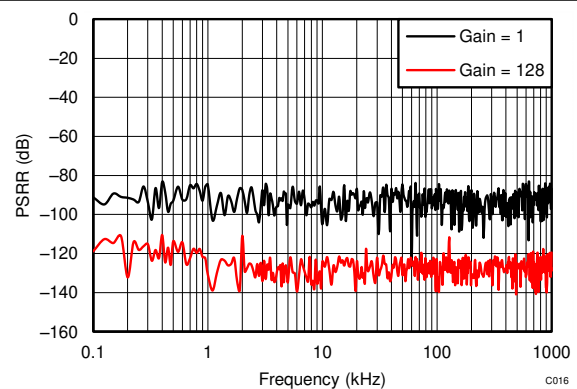


**Figure 6-12. Internal Reference Voltage vs Temperature**



DVDD = 3.3V, normal mode

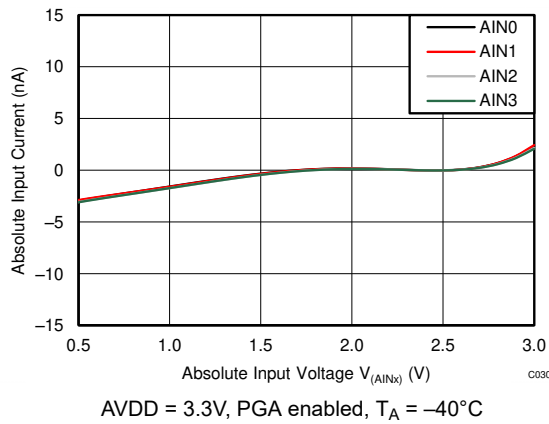
**Figure 6-13. Internal Oscillator Accuracy vs Temperature**



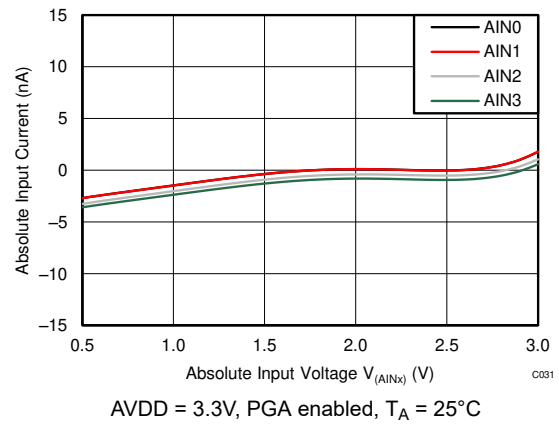
**Figure 6-14. AVDD Power-Supply Rejection Ratio vs Frequency**

## 6.9 Typical Characteristics (continued)

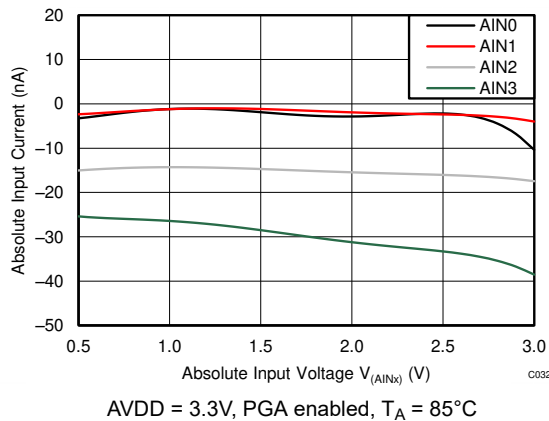
at  $T_A = 25^\circ\text{C}$ ,  $AVDD = 3.3\text{V}$ ,  $AVSS = 0\text{V}$ , and PGA enabled using external  $V_{REF} = 2.5\text{V}$  (unless otherwise noted).



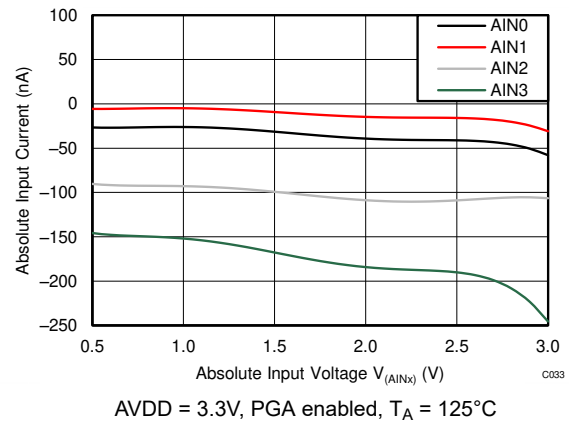
**Figure 6-15. Absolute Input Current vs Absolute Input Voltage**



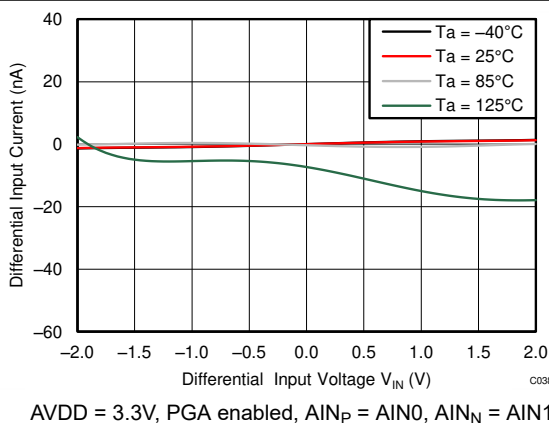
**Figure 6-16. Absolute Input Current vs Absolute Input Voltage**



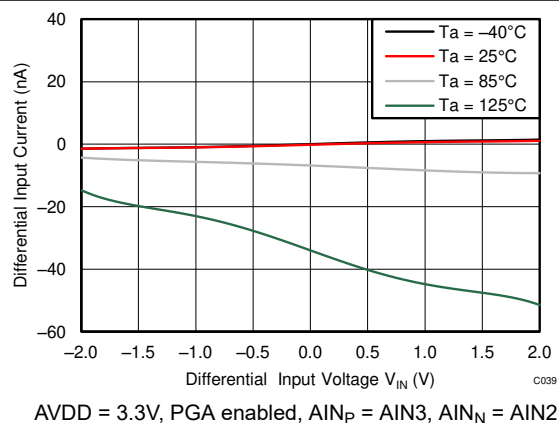
**Figure 6-17. Absolute Input Current vs Absolute Input Voltage**



**Figure 6-18. Absolute Input Current vs Absolute Input Voltage**



**Figure 6-19. Differential Input Current vs Differential Input Voltage**



**Figure 6-20. Differential Input Current vs Differential Input Voltage**

## 6.9 Typical Characteristics (continued)

at  $T_A = 25^\circ\text{C}$ ,  $AVDD = 3.3\text{V}$ ,  $AVSS = 0\text{V}$ , and PGA enabled using external  $V_{REF} = 2.5\text{V}$  (unless otherwise noted).

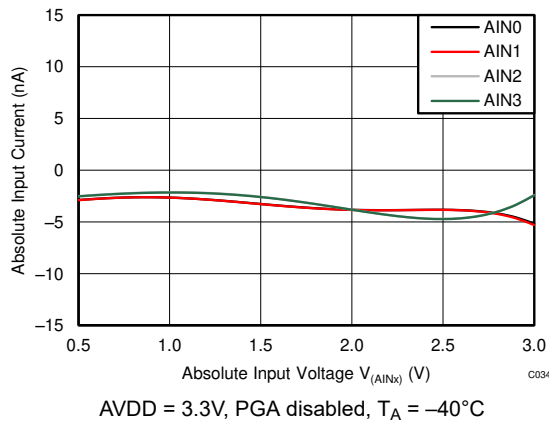


Figure 6-21. Absolute Input Current vs Absolute Input Voltage

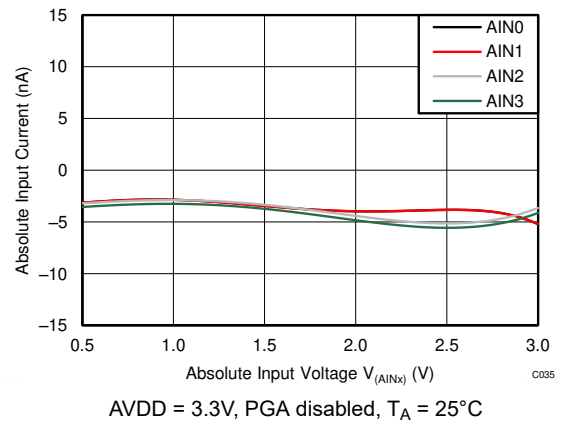


Figure 6-22. Absolute Input Current vs Absolute Input Voltage

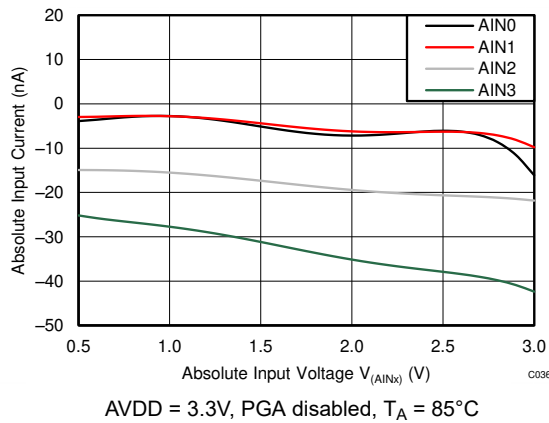


Figure 6-23. Absolute Input Current vs Absolute Input Voltage

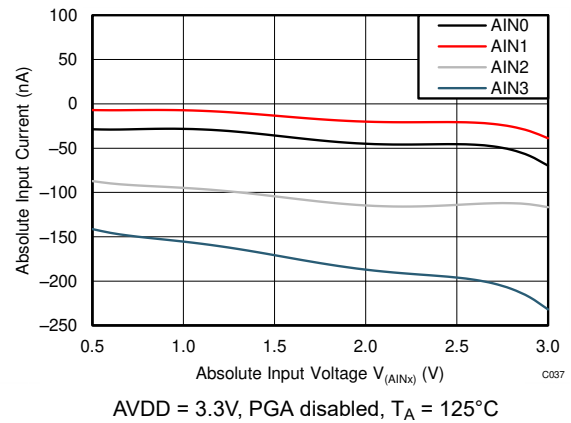


Figure 6-24. Absolute Input Current vs Absolute Input Voltage

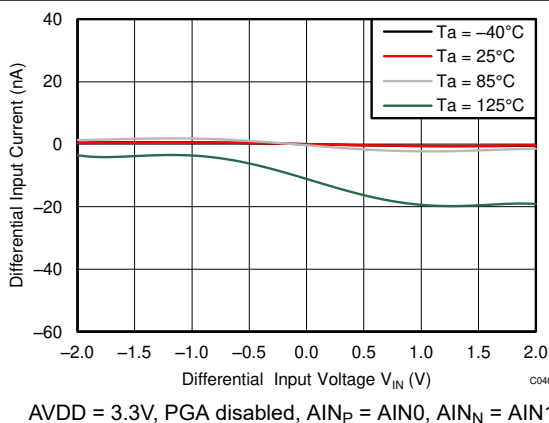


Figure 6-25. Differential Input Current vs Differential Input Voltage

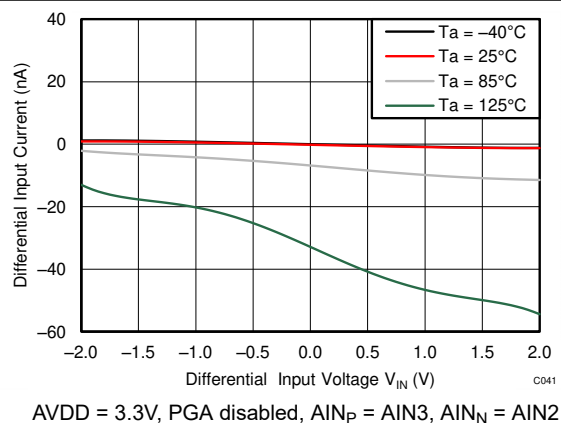


Figure 6-26. Differential Input Current vs Differential Input Voltage

### 6.9 Typical Characteristics (continued)

at  $T_A = 25^\circ\text{C}$ ,  $AVDD = 3.3\text{V}$ ,  $AVSS = 0\text{V}$ , and PGA enabled using external  $V_{REF} = 2.5\text{V}$  (unless otherwise noted).

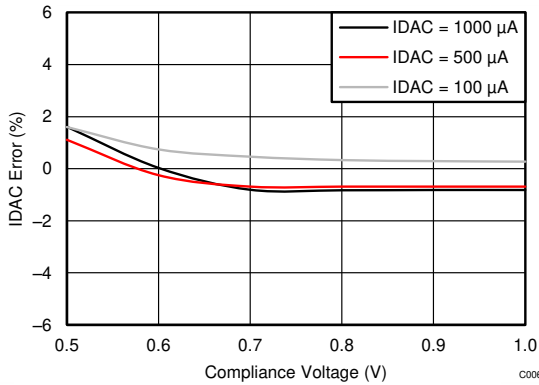


Figure 6-27. IDAC Accuracy vs Compliance Voltage

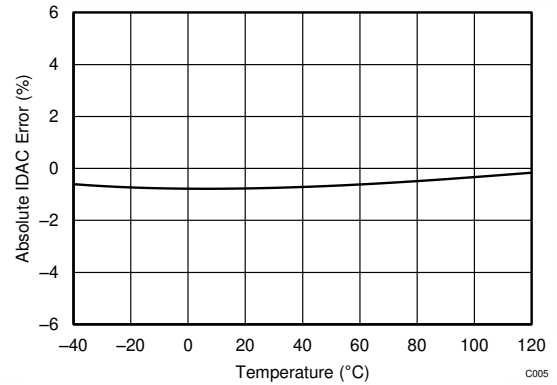


Figure 6-28. IDAC Accuracy vs Temperature

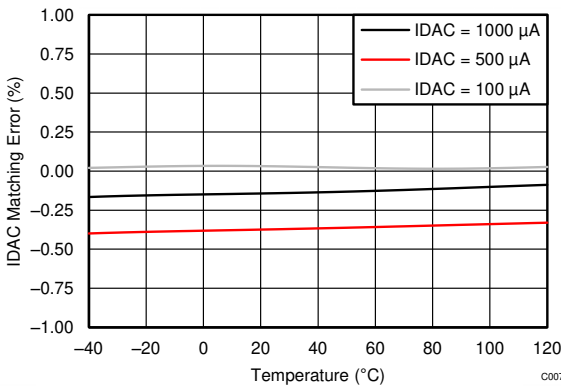
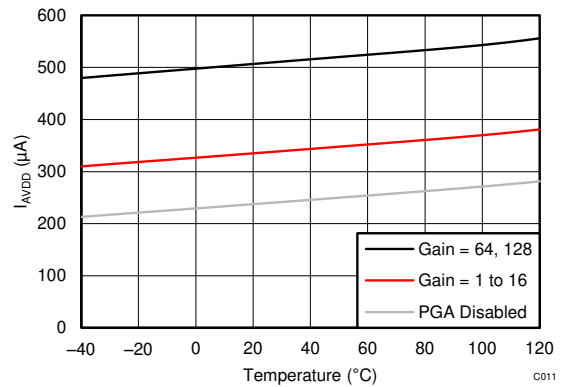
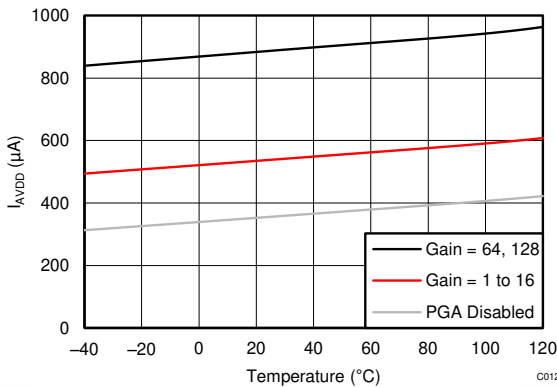


Figure 6-29. IDAC Matching vs Temperature



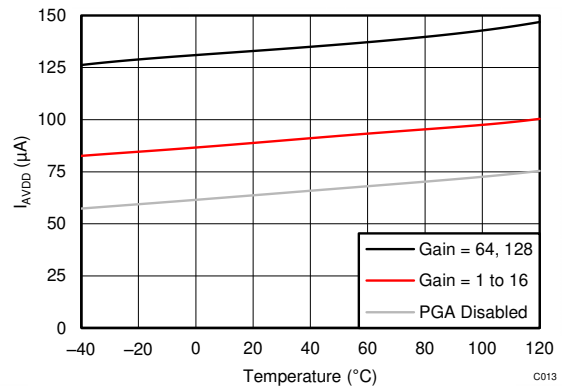
$AVDD = 3.3\text{V}$ , internal reference, normal mode

Figure 6-30.  $I_{AVDD}$  vs Temperature



$AVDD = 3.3\text{V}$ , internal reference, turbo mode

Figure 6-31.  $I_{AVDD}$  vs Temperature

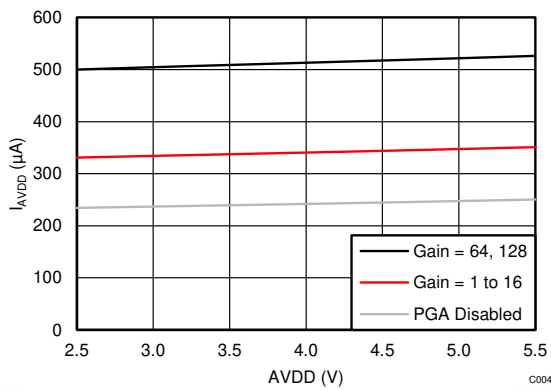


$AVDD = 3.3\text{V}$ , internal reference, duty-cycle mode

Figure 6-32.  $I_{AVDD}$  vs Temperature

### 6.9 Typical Characteristics (continued)

at  $T_A = 25^\circ\text{C}$ ,  $AVDD = 3.3\text{V}$ ,  $AVSS = 0\text{V}$ , and PGA enabled using external  $V_{REF} = 2.5\text{V}$  (unless otherwise noted).



Normal mode, internal reference

Figure 6-33.  $I_{AVDD}$  vs  $AVDD$

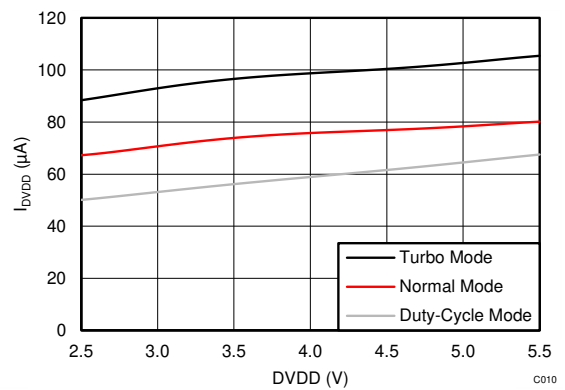


Figure 6-34.  $I_{DVDD}$  vs  $DVDD$

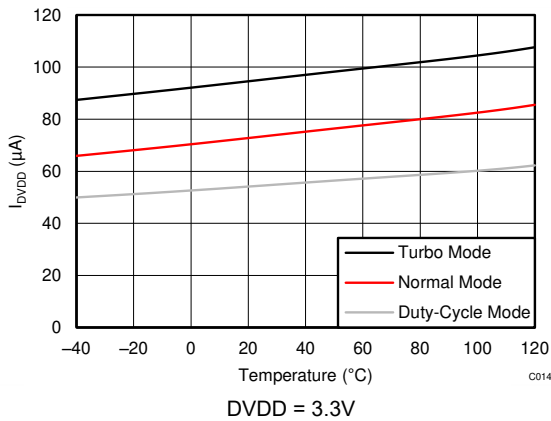


Figure 6-35.  $I_{DVDD}$  vs Temperature

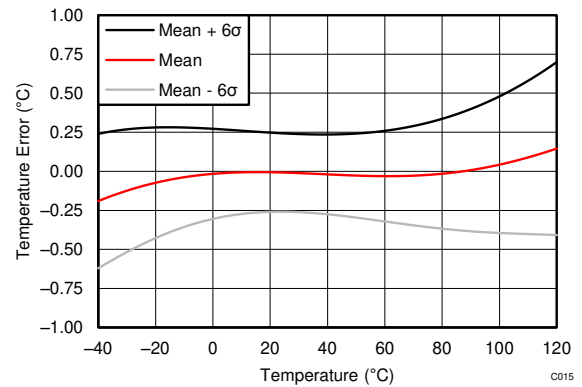


Figure 6-36. Internal Temperature Sensor Accuracy vs Temperature

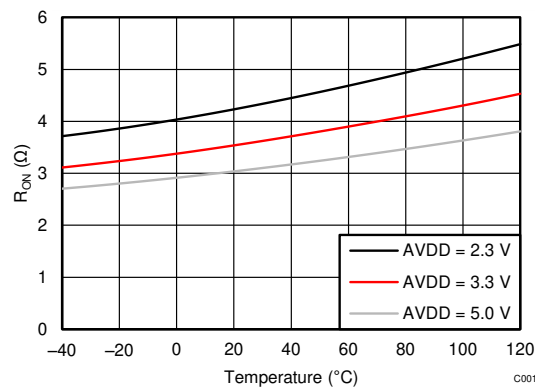


Figure 6-37. Low-Side Power Switch  $R_{ON}$  vs Temperature

## 7 Parameter Measurement Information

### 7.1 Noise Performance

Delta-sigma ( $\Delta\Sigma$ ) analog-to-digital converters (ADCs) are based on the principle of oversampling. The input signal of a  $\Delta\Sigma$  ADC is sampled at a high frequency (modulator frequency) and subsequently filtered and decimated in the digital domain to yield a conversion result at the respective output data rate. The ratio between modulator frequency and output data rate is called *oversampling ratio* (OSR). By increasing the OSR, and thus reducing the output data rate, the noise performance of the ADC can be optimized. In other words, the input-referred noise drops when reducing the output data rate because more samples of the internal modulator are averaged to yield one conversion result. Increasing the gain also reduces the input-referred noise, which is particularly useful when measuring low-level signals.

Table 7-1 to Table 7-8 summarize the device noise performance. Data are representative of typical noise performance at  $T_A = 25^\circ\text{C}$  using the internal 2.048V reference. Data shown are the result of averaging readings from a single device over a time period of approximately 0.75 seconds and are measured with the inputs internally shorted together. Table 7-1, Table 7-3, Table 7-5 and Table 7-7 list the input-referred noise in units of  $\mu\text{V}_{\text{RMS}}$  for the conditions shown. Values in  $\mu\text{V}_{\text{PP}}$  are shown in parenthesis. Table 7-2, Table 7-4, Table 7-6 and Table 7-8 list the corresponding data in effective resolution calculated from  $\mu\text{V}_{\text{RMS}}$  values using Equation 1. Noise-free resolution calculated from peak-to-peak noise values using Equation 2 are shown in parenthesis.

The input-referred noise (Table 7-1, Table 7-3, Table 7-5 and Table 7-7) only changes marginally when using an external low-noise reference, such as the REF5020. Use Equation 1 and Equation 2 to calculate effective resolution numbers and noise-free resolution when using a reference voltage other than 2.048V:

$$\text{Effective Resolution} = \ln [2 \times V_{\text{REF}} / (\text{Gain} \times V_{\text{RMS-Noise}})] / \ln(2) \quad (1)$$

$$\text{Noise-Free Resolution} = \ln [2 \times V_{\text{REF}} / (\text{Gain} \times V_{\text{PP-Noise}})] / \ln(2) \quad (2)$$

**Table 7-1. Noise in  $\mu\text{V}_{\text{RMS}}$  ( $\mu\text{V}_{\text{PP}}$ )  
at AVDD = 3.3V, AVSS = 0V, Normal Mode, and Internal Reference = 2.048V**

DATA RATE (SPS)	GAIN (PGA Enabled)							
	1	2	4	8	16	32	64	128
20	3.71 (13.67)	1.54 (5.37)	1.15 (4.15)	0.80 (3.36)	0.35 (1.16)	0.23 (0.73)	0.10 (0.35)	0.09 (0.41)
45	7.36 (29.54)	2.93 (13.06)	1.71 (9.28)	0.88 (4.06)	0.50 (2.26)	0.29 (1.49)	0.19 (0.82)	0.12 (0.51)
90	10.55 (47.36)	4.50 (20.75)	2.43 (11.35)	1.51 (6.65)	0.65 (3.62)	0.42 (2.14)	0.27 (1.22)	0.18 (0.85)
175	11.90 (63.72)	6.45 (34.06)	3.26 (17.76)	1.82 (11.20)	1.01 (5.13)	0.57 (3.09)	0.34 (2.14)	0.26 (1.60)
330	19.19 (106.93)	9.38 (50.78)	4.25 (26.25)	2.68 (14.13)	1.45 (7.52)	0.79 (4.66)	0.50 (2.69)	0.34 (1.99)
600	24.78 (151.61)	13.35 (72.27)	6.68 (39.43)	3.66 (19.26)	2.10 (12.77)	1.14 (6.87)	0.70 (4.76)	0.55 (3.34)
1000	37.53 (227.29)	18.87 (122.68)	9.53 (58.53)	5.37 (31.52)	2.95 (18.08)	1.65 (10.71)	1.03 (6.52)	0.70 (4.01)

**Table 7-2. Effective Resolution From RMS Noise (Noise-Free Resolution From Peak-to-Peak Noise)  
at AVDD = 3.3V, AVSS = 0V, Normal Mode, and Internal Reference = 2.048V**

DATA RATE (SPS)	GAIN (PGA Enabled)							
	1	2	4	8	16	32	64	128
20	20.08 (18.19)	20.34 (18.54)	19.76 (17.91)	19.28 (17.22)	19.48 (17.75)	19.10 (17.42)	19.33 (17.49)	18.49 (16.26)
45	19.09 (17.08)	19.42 (17.26)	19.19 (16.75)	19.15 (16.94)	18.95 (16.79)	18.74 (16.39)	18.38 (16.25)	18.00 (15.49)
90	18.57 (16.40)	18.80 (16.59)	18.68 (16.46)	18.37 (16.23)	18.60 (16.11)	18.20 (15.87)	17.87 (15.67)	17.44 (15.20)
175	18.39 (15.97)	18.28 (15.88)	18.26 (15.82)	18.10 (15.48)	17.96 (15.61)	17.78 (15.34)	17.53 (14.87)	16.91 (14.29)
330	17.70 (15.23)	17.74 (15.30)	17.88 (15.25)	17.54 (15.15)	17.43 (15.05)	17.30 (14.74)	16.96 (14.54)	16.50 (13.97)
600	17.33 (14.72)	17.23 (14.79)	17.23 (14.66)	17.09 (14.70)	16.89 (14.29)	16.77 (14.18)	16.48 (13.72)	15.83 (13.23)
1000	16.74 (14.14)	16.73 (14.03)	16.71 (14.09)	16.54 (13.99)	16.41 (13.79)	16.25 (13.54)	15.92 (13.26)	15.49 (12.96)

**Table 7-3. Noise in  $\mu\text{V}_{\text{RMS}}$  ( $\mu\text{V}_{\text{PP}}$ ) With PGA Disabled  
at AVDD = 3.3V, AVSS = 0V, Normal Mode, and Internal Reference = 2.048V**

DATA RATE (SPS)	GAIN (PGA Disabled)		
	1	2	4
20	3.89 (13.43)	1.85 (6.84)	1.26 (3.91)
45	6.97 (31.98)	2.94 (12.94)	1.41 (5.62)
90	8.50 (42.48)	4.49 (18.92)	2.07 (9.95)
175	12.99 (65.92)	6.24 (35.40)	3.04 (18.92)
330	18.18 (94.24)	8.12 (50.17)	4.71 (28.75)
600	25.29 (138.67)	12.77 (78.13)	6.27 (39.79)
1000	38.04 (260.50)	18.40 (120.97)	9.48 (63.72)

**Table 7-4. Effective Resolution From RMS Noise (Noise-Free Resolution From Peak-to-Peak Noise) With  
PGA Disabled at AVDD = 3.3V, AVSS = 0V, Normal Mode, and Internal Reference = 2.048V**

DATA RATE (SPS)	GAIN (PGA Disabled)		
	1	2	4
20	20.01 (18.22)	20.08 (18.19)	19.63 (18.00)
45	19.61 (16.97)	19.41 (17.27)	19.47 (17.48)
90	18.88 (16.56)	18.80 (16.72)	18.91 (16.65)
175	18.27 (15.92)	18.32 (15.82)	18.36 (15.72)
330	17.78 (15.41)	17.94 (15.32)	17.73 (15.12)
600	17.31 (14.85)	17.29 (14.68)	17.32 (14.65)
1000	16.72 (13.94)	16.76 (14.05)	16.72 (13.97)

**Table 7-5. Noise in  $\mu\text{V}_{\text{RMS}}$  ( $\mu\text{V}_{\text{PP}}$ )  
at AVDD = 3.3V, AVSS = 0V, Turbo Mode, and Internal Reference = 2.048V**

DATA RATE (SPS)	GAIN (PGA Enabled)							
	1	2	4	8	16	32	64	128
40	4.56 (24.17)	2.40 (11.35)	1.22 (4.94)	0.71 (2.84)	0.35 (1.60)	0.19 (0.85)	0.16 (0.71)	0.09 (0.55)
90	5.74 (25.88)	2.97 (14.40)	1.47 (5.80)	1.13 (5.52)	0.50 (2.67)	0.32 (1.32)	0.23 (1.13)	0.15 (0.69)
180	8.49 (46.88)	4.66 (21.36)	2.30 (12.88)	1.24 (7.23)	0.72 (4.82)	0.42 (2.57)	0.28 (1.47)	0.24 (1.34)
350	13.42 (84.72)	5.86 (40.04)	3.39 (19.04)	1.88 (10.13)	1.05 (6.15)	0.64 (3.59)	0.43 (2.29)	0.28 (1.39)
660	17.09 (120.36)	9.34 (47.36)	4.81 (27.83)	2.97 (17.36)	1.54 (10.21)	0.82 (4.43)	0.58 (3.67)	0.41 (2.93)
1200	25.71 (162.35)	12.31 (85.94)	6.81 (44.01)	3.72 (21.55)	2.09 (15.14)	1.23 (7.58)	0.80 (5.31)	0.57 (3.51)
2000	36.23 (265.14)	18.24 (127.32)	9.24 (65.43)	5.49 (37.02)	2.89 (18.89)	1.77 (12.00)	1.13 (7.60)	0.82 (5.81)

**Table 7-6. Effective Resolution From RMS Noise (Noise-Free Resolution From Peak-to-Peak Noise)  
at AVDD = 3.3V, AVSS = 0V, Turbo Mode, and Internal Reference = 2.048V**

DATA RATE (SPS)	GAIN (PGA Enabled)							
	1	2	4	8	16	32	64	128
40	19.78 (17.37)	19.71 (17.46)	19.68 (17.66)	19.45 (17.46)	19.47 (17.29)	19.37 (17.21)	18.65 (16.46)	18.40 (15.83)
90	19.45 (17.27)	19.39 (17.12)	19.41 (17.43)	18.79 (16.50)	18.97 (16.55)	18.62 (16.57)	18.11 (15.80)	17.75 (15.49)
180	18.88 (16.42)	18.75 (16.55)	18.76 (16.28)	18.65 (16.11)	18.43 (15.70)	18.23 (15.60)	17.79 (15.41)	17.05 (14.54)
350	18.22 (15.56)	18.42 (15.64)	18.21 (15.71)	18.05 (15.62)	17.89 (15.35)	17.62 (15.12)	17.20 (14.77)	16.78 (14.49)
660	17.87 (15.05)	17.74 (15.40)	17.70 (15.17)	17.39 (14.85)	17.34 (14.61)	17.25 (14.82)	16.75 (14.09)	16.25 (13.42)
1200	17.28 (14.62)	17.34 (14.54)	17.20 (14.51)	17.07 (14.54)	16.90 (14.05)	16.67 (14.04)	16.28 (13.56)	15.77 (13.15)
2000	16.79 (13.92)	16.78 (13.97)	16.76 (13.93)	16.51 (13.76)	16.44 (13.73)	16.14 (13.38)	15.79 (13.04)	15.25 (12.43)

**Table 7-7. Noise in  $\mu\text{V}_{\text{RMS}}$  ( $\mu\text{V}_{\text{PP}}$ ) With PGA Disabled  
at AVDD = 3.3V, AVSS = 0V, Turbo Mode, and Internal Reference = 2.048V**

DATA RATE (SPS)	GAIN (PGA Disabled)		
	1	2	4
40	4.22 (22.46)	2.30 (10.74)	0.93 (3.91)
90	6.57 (31.01)	3.53 (14.28)	1.59 (6.84)
180	8.41 (55.66)	4.30 (22.09)	2.31 (14.59)
350	12.68 (75.20)	6.02 (34.18)	3.22 (17.64)
660	17.81 (111.08)	9.06 (56.76)	4.24 (27.47)
1200	25.43 (176.03)	12.70 (89.23)	6.28 (40.95)
2000	36.11 (250.98)	17.30 (131.35)	8.77 (68.18)

**Table 7-8. Effective Resolution From RMS Noise (Noise-Free Resolution From Peak-to-Peak Noise) With  
PGA Disabled at AVDD = 3.3V, AVSS = 0V, Turbo Mode, and Internal Reference = 2.048V**

DATA RATE (SPS)	GAIN (PGA Disabled)		
	1	2	4
40	19.89 (17.48)	19.76 (17.54)	20.07 (18.00)
90	19.25 (17.01)	19.15 (17.13)	19.29 (17.19)
180	18.89 (16.17)	18.86 (16.50)	18.76 (16.10)
350	18.30 (15.73)	18.38 (15.87)	18.28 (15.83)
660	17.81 (15.17)	17.79 (15.14)	17.88 (15.19)
1200	17.30 (14.51)	17.30 (14.49)	17.31 (14.61)
2000	16.79 (13.99)	16.85 (13.93)	16.83 (13.87)

## 8 Detailed Description

### 8.1 Overview

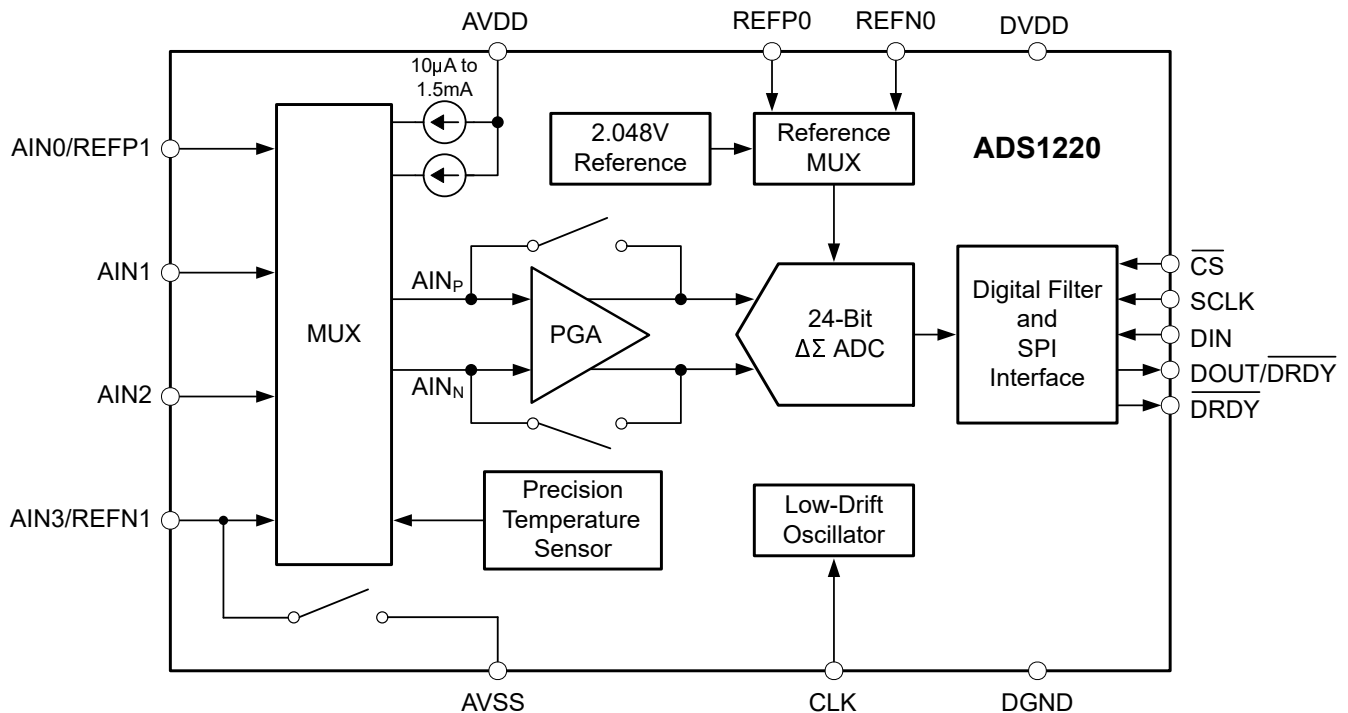
The ADS1220 is a small, low-power, 24-bit,  $\Delta\Sigma$  ADC that offers many integrated features to reduce system cost and component count in applications measuring small sensor signals.

In addition to the  $\Delta\Sigma$  ADC core and single-cycle settling digital filter, the device offers a low-noise, high input impedance, programmable gain amplifier (PGA), an internal voltage reference, and a clock oscillator. The device also integrates a highly linear and accurate temperature sensor as well as two matched programmable current sources (IDACs) for sensor excitation. All of these features are intended to reduce the required external circuitry in typical sensor applications and improve overall system performance. An additional low-side power switch eases the design of low-power bridge sensor applications. The device is fully configured through four registers and controlled by six commands through a mode 1 SPI-compatible interface. The [Functional Block Diagram](#) section shows the device functional block diagram.

The ADS1220 ADC measures a differential signal,  $V_{IN}$ , which is the difference in voltage between nodes  $AIN_P$  and  $AIN_N$ . The converter core consists of a differential, switched-capacitor,  $\Delta\Sigma$  modulator followed by a digital filter. The digital filter receives a high-speed bitstream from the modulator and outputs a code proportional to the input voltage. This architecture results in a very strong attenuation of any common-mode signal.

The device has two available conversion modes: single-shot and continuous conversion mode. In single-shot conversion mode, the ADC performs one conversion of the input signal upon request and stores the value in an internal data buffer. The device then enters a low-power state to save power. Single-shot conversion mode is intended to provide significant power savings in systems that require only periodic conversions, or when there are long idle periods between conversions. In continuous conversion mode, the ADC automatically begins a conversion of the input signal as soon as the previous conversion is completed. New data are available at the programmed data rate. Data can be read at any time without concern of data corruption and always reflect the most recently completed conversion.

### 8.2 Functional Block Diagram



### 8.3 Feature Description

#### 8.3.1 Multiplexer

Figure 8-1 shows the flexible input multiplexer of the device. Either four single-ended signals, two differential signals, or a combination of two single-ended signals and one differential signal can be measured. Use the MUX[3:0] bits in the configuration register to configure the multiplexer. When single-ended signals are measured, the negative ADC input ( $A_{IN_N}$ ) is internally connected to AVSS by a switch within the multiplexer. For system-monitoring purposes, the analog supply ( $AVDD - AVSS$ ) / 4 or the currently-selected external reference voltage ( $V_{REFP_X} - V_{REFN_X}$ ) / 4 can be selected as inputs to the ADC. The multiplexer also offers the possibility to route any of the two programmable current sources to any analog input ( $A_{IN_x}$ ) or to any dedicated reference pin ( $REFP_0$ ,  $REFN_0$ ).

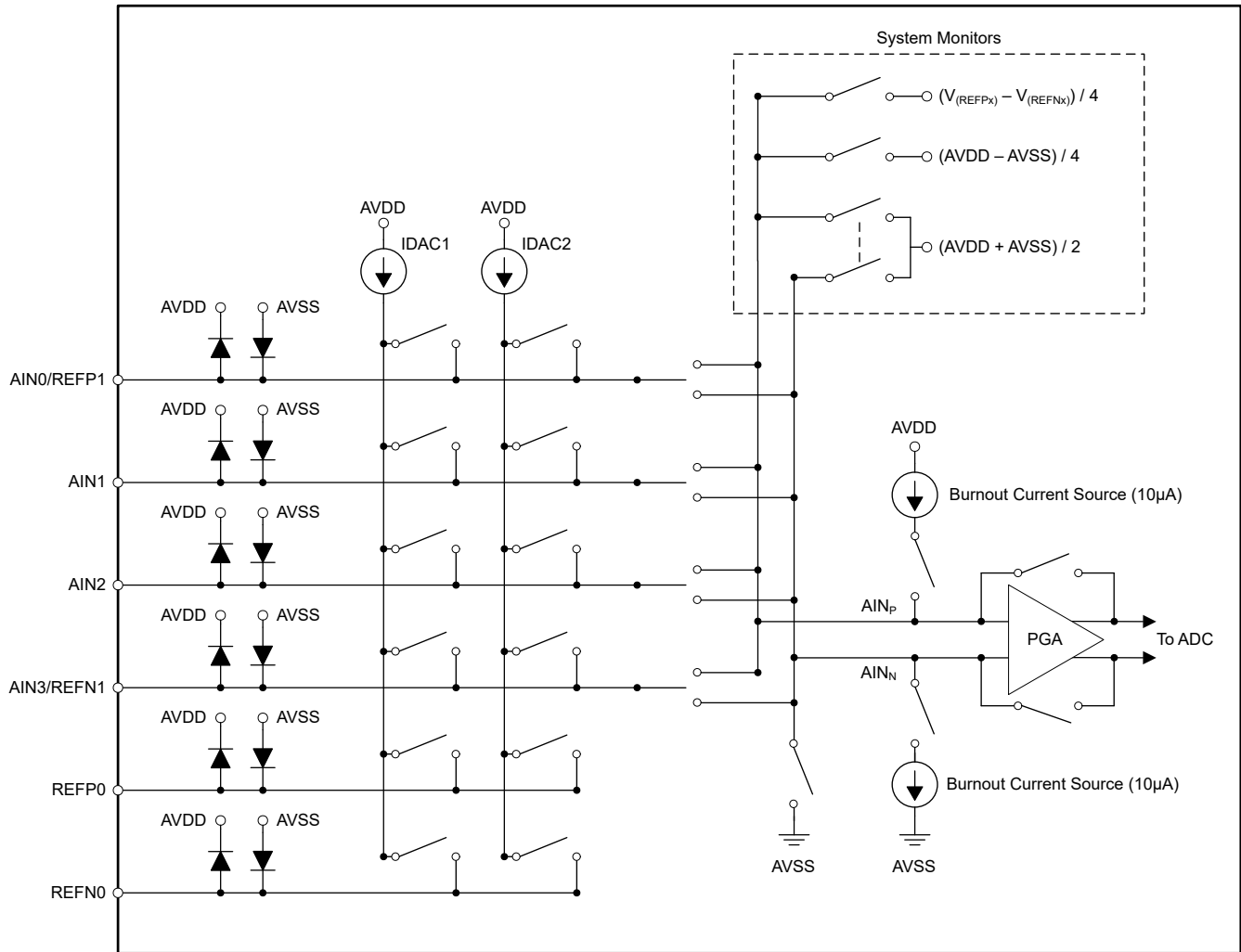


Figure 8-1. Analog Input Multiplexer

Electrostatic discharge (ESD) diodes to AVDD and AVSS protect the inputs. To prevent the ESD diodes from turning on, the absolute voltage on any input must stay within the range provided by Equation 3:

$$AVSS - 0.3V < V_{(A_{IN_x})} < AVDD + 0.3V \tag{3}$$

If the voltages on the input pins have any potential to violate these conditions, external Schottky clamp diodes or series resistors can be required to limit the input current to safe values (see the [Absolute Maximum Ratings](#) table). Overdriving an unused input on the device can affect conversions taking place on other input pins.

### 8.3.2 Low-Noise PGA

The device features programmable gains of 1, 2, 4, 8, 16, 32, 64, and 128. Use the GAIN[2:0] bits in the configuration register to configure the gain. Gains are achieved in two stages. The first stage is a low-noise, low-drift, high input impedance, programmable gain amplifier (PGA). The second gain stage is implemented by a switched-capacitor circuit at the input to the  $\Delta\Sigma$  modulator. Table 8-1 shows how each gain is implemented.

Table 8-1. Gain Implementation

GAIN SETTING	PGA GAIN	SWITCHED-CAPACITOR GAIN
1	1	1
2	1	2
4	1	4
8	2	4
16	4	4
32	8	4
64	16	4
128	32	4

The PGA consists of two chopper-stabilized amplifiers (A1 and A2) and a resistor feedback network that sets the PGA gain. The PGA input is equipped with an electromagnetic interference (EMI) filter. Figure 8-2 shows a simplified diagram of the PGA.

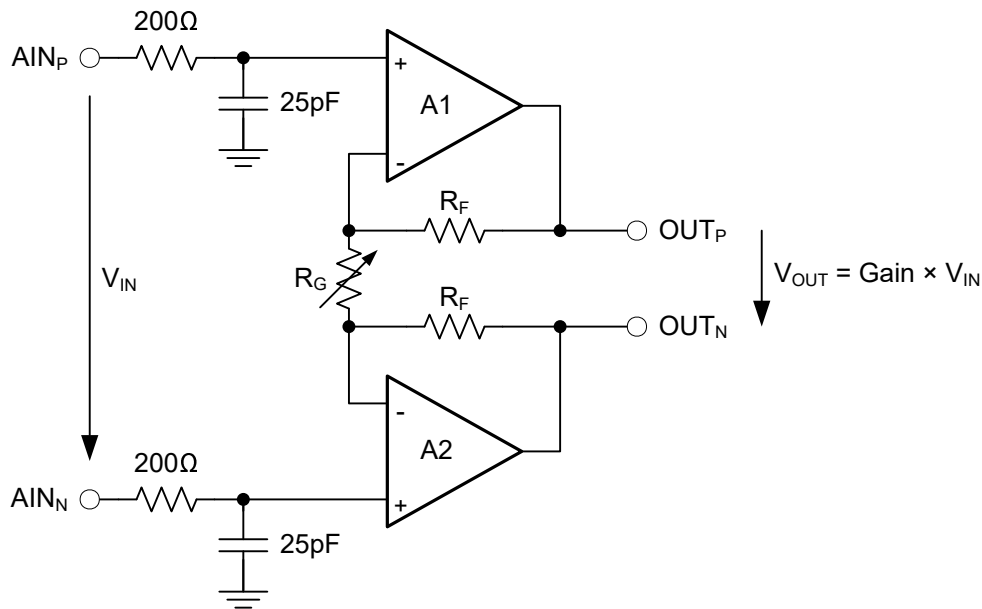


Figure 8-2. Simplified PGA Diagram

V<sub>IN</sub> denotes the differential input voltage  $V_{IN} = (V_{AINP} - V_{AINN})$ . The gain of the PGA can be calculated with Equation 4:

$$\text{Gain} = 1 + 2 \times R_F / R_G \quad (4)$$

Gain is changed inside the device using a variable resistor, R<sub>G</sub>. The differential full-scale input voltage range (FSR) of the PGA is defined by the gain setting and the reference voltage used, as shown in Equation 5:

$$\text{FSR} = \pm V_{REF} / \text{Gain} \quad (5)$$

Table 8-2 shows the corresponding full-scale ranges when using the internal 2.048V reference.

**Table 8-2. PGA Full-Scale Range**

GAIN SETTING	FSR
1	±2.048V
2	±1.024V
4	±0.512V
8	±0.256V
16	±0.128V
32	±0.064V
64	±0.032V
128	±0.016V

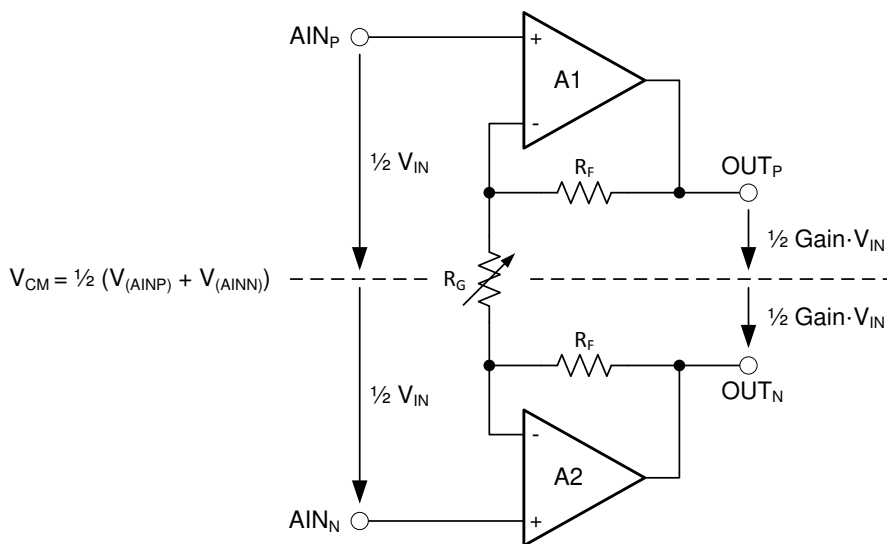
**8.3.2.1 PGA Common-Mode Voltage Requirements**

To stay within the linear operating range of the PGA, the input signals must meet certain requirements that are discussed in this section.

The outputs of both amplifiers (A1 and A2) in [Figure 8-2](#) cannot swing closer to the supplies (AVSS and AVDD) than 200mV. If the outputs OUT<sub>P</sub> and OUT<sub>N</sub> are driven to within 200mV of the supply rails, the amplifiers saturate and consequently become nonlinear. To prevent this nonlinear operating condition the output voltages must meet [Equation 6](#):

$$AVSS + 0.2V \leq V_{OUTN}, V_{OUTP} \leq AVDD - 0.2V \tag{6}$$

Translating the requirements of [Equation 6](#) into requirements referred to the PGA inputs (AIN<sub>P</sub> and AIN<sub>N</sub>) is beneficial because there is no direct access to the outputs of the PGA. The PGA employs a symmetrical design, therefore the common-mode voltage at the output of the PGA can be assumed to be the same as the common-mode voltage of the input signal, as shown in [Figure 8-3](#).



**Figure 8-3. PGA Common-Mode Voltage**

The common-mode voltage is calculated using [Equation 7](#):

$$V_{CM} = \frac{1}{2} (V_{AINP} + V_{AINN}) = \frac{1}{2} (V_{OUTP} + V_{OUTN}) \tag{7}$$

The voltages at the PGA inputs ( $V_{AINP}$  and  $V_{AINN}$ ) can be expressed as [Equation 8](#) and [Equation 9](#):

$$V_{AINP} = V_{CM} + \frac{1}{2} V_{IN} \quad (8)$$

$$V_{AINN} = V_{CM} - \frac{1}{2} V_{IN} \quad (9)$$

The output voltages ( $V_{OUTP}$  and  $V_{OUTN}$ ) can then be calculated as [Equation 10](#) and [Equation 11](#):

$$V_{OUTP} = V_{CM} + \frac{1}{2} \text{Gain} \times V_{IN} \quad (10)$$

$$V_{OUTN} = V_{CM} - \frac{1}{2} \text{Gain} \times V_{IN} \quad (11)$$

The requirements for the output voltages of amplifiers A1 and A2 ([Equation 6](#)) can now be translated into requirements for the input common-mode voltage range using [Equation 10](#) and [Equation 11](#), which are given in [Equation 12](#) and [Equation 13](#):

$$V_{CMMIN} \geq AVSS + 0.2V + \frac{1}{2} \text{Gain} \times V_{INMAX} \quad (12)$$

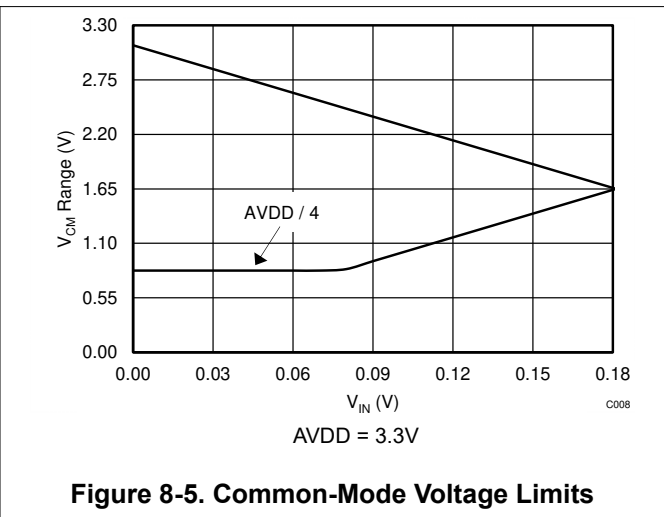
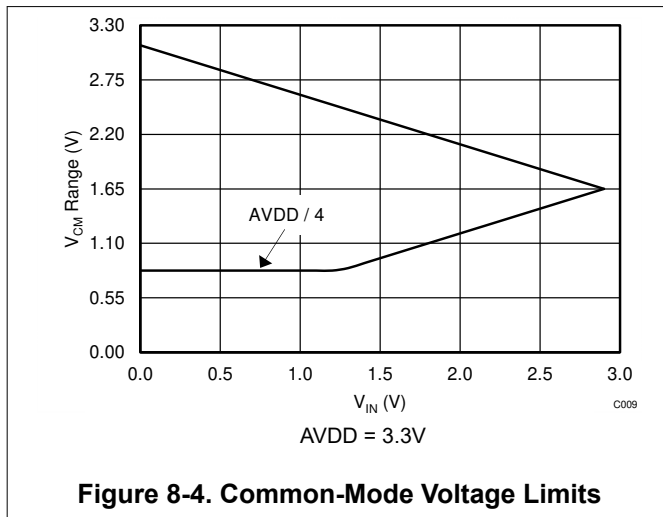
$$V_{CMMAX} \leq AVDD - 0.2V - \frac{1}{2} \text{Gain} \times V_{INMAX} \quad (13)$$

To calculate the minimum and maximum common-mode voltage limits, the maximum differential input voltage ( $V_{INMAX}$ ) that occurs in the application must be used.  $V_{INMAX}$  can be less than the maximum possible FS value.

In addition to [Equation 12](#), the minimum  $V_{CM}$  must also meet [Equation 14](#) because of the specific design implementation of the PGA.

$$V_{CMMIN} \geq AVSS + \frac{1}{4} (AVDD - AVSS) \quad (14)$$

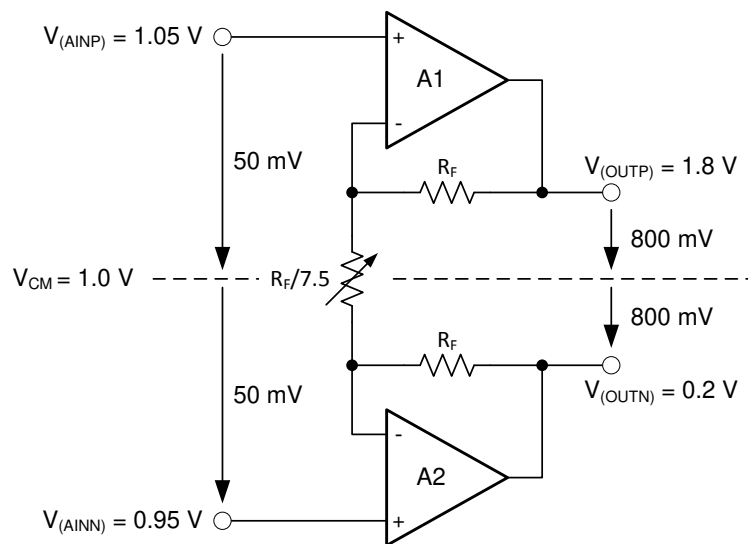
[Figure 8-4](#) and [Figure 8-5](#) show a graphical representation of the common-mode voltage limits for  $AVDD = 3.3V$  and  $AVSS = 0V$ , with gain = 1 and gain = 16, respectively.



The following discussion explains how to apply Equation 12 through Equation 14 to a hypothetical application. The setup for this example is  $AV_{DD} = 3.3V$ ,  $AV_{SS} = 0V$ , and gain = 16, using an external reference,  $V_{REF} = 2.5V$ . The maximum possible differential input voltage  $V_{IN} = (V_{AINP} - V_{AINN})$  that can be applied is then limited to the full-scale range of  $FSR = \pm 2.5V / 16 = \pm 0.156V$ . Consequently, Equation 12 through Equation 14 yield an allowed  $V_{CM}$  range of  $1.45V \leq V_{CM} \leq 1.85V$ .

If the sensor signal connected to the inputs in this hypothetical application does not make use of the entire full-scale range but is limited to  $V_{IN(MAX)} = \pm 0.1V$ , for example, then this reduced input signal amplitude relaxes the  $V_{CM}$  restriction to  $1.0V \leq V_{CM} \leq 2.3V$ .

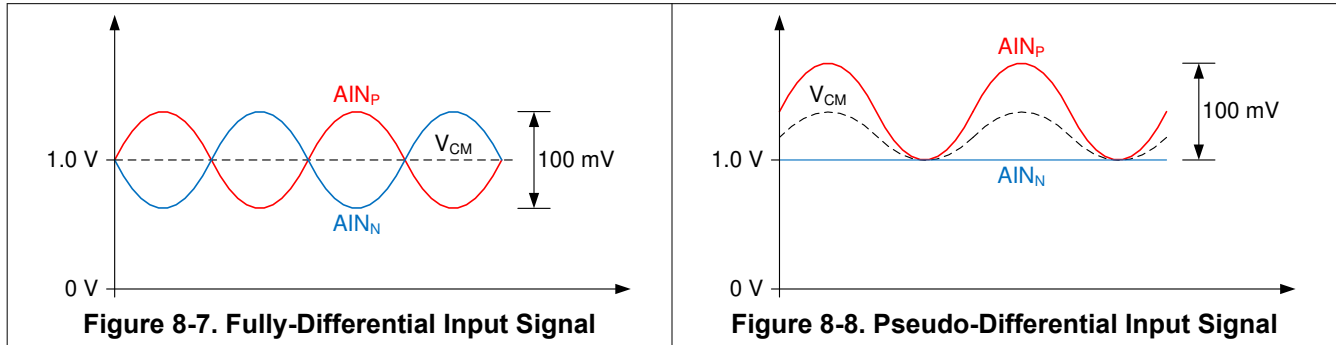
In the case of a fully-differential sensor signal, each input ( $A_{INP}$ ,  $A_{INN}$ ) can swing up to  $\pm 50mV$  around the common-mode voltage  $(V_{AINP} + V_{AINN}) / 2$ , which must remain between the limits of 1.0V and 2.3V. The output of a symmetrical Wheatstone bridge is an example of a fully-differential signal. Figure 8-6 shows a situation where the common-mode voltage of the input signal is at the lowest limit.  $V_{OUTN}$  is exactly at 0.2V in this case. Any further decrease in common-mode voltage ( $V_{CM}$ ) or increase in differential input voltage ( $V_{IN}$ ) drives  $V_{OUTN}$  below 0.2V and saturates amplifier A2.



**Figure 8-6. Example Where  $V_{CM}$  is at Lowest Limit**

In contrast, the signal of an RTD is of a pseudo-differential nature (if implemented as shown in the [RTD Measurement](#) section), where the negative input is held at a constant voltage other than 0V and only the voltage on the positive input changes. When a pseudo-differential signal must be measured, the negative input in this example must be biased at a voltage between 0.95V and 2.25V. The positive input can then swing up to  $V_{INMAX} = 100mV$  above the negative input. In this case the common-mode voltage changes at the same time the voltage on the positive input changes. That is, while the input signal swings between  $0V \leq V_{IN} \leq V_{INMAX}$ , the common-mode voltage swings between  $V_{AINN} \leq V_{CM} \leq V_{AINN} + \frac{1}{2} V_{INMAX}$ . The requirements for the entire signal range are met if the common-mode voltage requirements for the maximum input voltage  $V_{INMAX}$  are satisfied.

Figure 8-7 and Figure 8-8 show examples of both fully-differential and pseudo-differential signals, respectively.



#### Note

Remember, common-mode voltage requirements with PGA enabled (Equation 12 to Equation 14) are as follows:

- $V_{CMMIN} \geq AVSS + \frac{1}{4} (AVDD - AVSS)$
- $V_{CMMIN} \geq AVSS + 0.2V + \frac{1}{2} \text{Gain} \times V_{INMAX}$
- $V_{CMMAX} \leq AVDD - 0.2V - \frac{1}{2} \text{Gain} \times V_{INMAX}$

#### 8.3.2.2 Bypassing the PGA

At gains of 1, 2, and 4, set the PGA\_BYPASS bit in the configuration register to disable and bypass the low-noise PGA. Disabling the PGA lowers the overall power consumption and also removes the restrictions of Equation 12 through Equation 14 for the common-mode input voltage range,  $V_{CM}$ . The usable absolute and common-mode input voltage range is  $(AVSS - 0.1V \leq V_{AINx}, V_{CM} \leq AVDD + 0.1V)$  when the PGA is disabled.

To measure single-ended signals that are referenced to AVSS ( $AIN_P = V_{IN}$ ,  $AIN_N = AVSS$ ), the PGA must be bypassed. Configure the device for single-ended measurements by either connecting one of the analog inputs to AVSS externally or by using the internal AVSS connection of the multiplexer (MUX[3:0] settings 1000b through 1011b). The PGA is always enabled for gain settings greater than 4, regardless of the PGA\_BYPASS setting.

When the PGA is disabled, the device uses a buffered switched-capacitor stage to obtain gains 1, 2, and 4. An internal buffer in front of the switched-capacitor stage ensures that the effect on the input loading resulting from the capacitor charging and discharging is minimal. See Figure 6-21 to Figure 6-26 for the typical values of absolute input currents (current flowing into or out of each input) and differential input currents (difference in absolute current between positive and negative input) when the PGA is disabled.

For signal sources with high output impedance, external buffering can still be necessary. Active buffers introduce noise and also introduce offset and gain errors. Consider all of these factors in high-accuracy applications.

### 8.3.3 Voltage Reference

The device offers an integrated low-drift, 2.048V reference. For applications that require a different reference voltage value or a ratiometric measurement approach, the device offers two differential reference input pairs (REFP0, REFN0 and REFP1, REFN1). In addition, the analog supply (AVDD – AVSS) can be used as a reference.

The reference source is selected by two bits (VREF[1:0]) in the configuration register. By default, the internal reference is selected. The internal voltage reference requires less than 25 $\mu$ s to fully settle after power-up, when coming out of power-down mode, or when switching from an external reference source to the internal reference.

The differential reference inputs allow freedom in the reference common-mode voltage. REFP0 and REFN0 are dedicated reference inputs whereas REFP1 and REFN1 are shared with inputs AIN0 and AIN3, respectively. All reference inputs are internally buffered to increase input impedance. Therefore, additional reference buffers are typically not required when using an external reference. When used in ratiometric applications, the reference inputs do not load the external circuitry. The analog supply current increases when using an external reference because the reference buffers are enabled.

In most cases the conversion result is directly proportional to the stability of the reference source. Any noise and drift of the voltage reference is reflected in the conversion result.

### 8.3.4 Clock Source

The device system clock can either be provided by the internal low-drift oscillator or by an external clock source on the CLK input. Connect the CLK pin to DGND before power-up or reset to activate the internal oscillator. Connecting an external clock to the CLK pin at any time deactivates the internal oscillator after two rising edges on the CLK pin are detected. The device then operates on the external clock. After the ADS1220 switches to the external clock, the device can only be switched back to the internal oscillator by cycling the power supplies or by sending a RESET command.

### 8.3.5 Modulator

A  $\Delta\Sigma$  modulator is used in the ADS1220 to convert the analog input voltage into a pulse code modulated (PCM) data stream. The modulator runs at a modulator clock frequency of  $f_{\text{MOD}} = f_{\text{CLK}} / 16$  in normal and duty-cycle mode and  $f_{\text{MOD}} = f_{\text{CLK}} / 8$  in turbo mode, where  $f_{\text{CLK}}$  is either provided by the internal oscillator or the external clock source. [Table 8-3](#) shows the modulator frequency for each operating mode using either the internal oscillator or an external clock of 4.096MHz.

**Table 8-3. Modulator Clock Frequency for Different Operating Modes <sup>(1)</sup>**

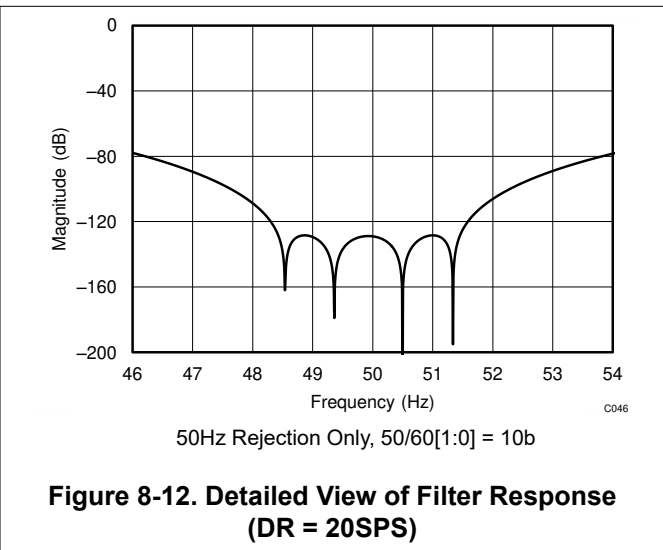
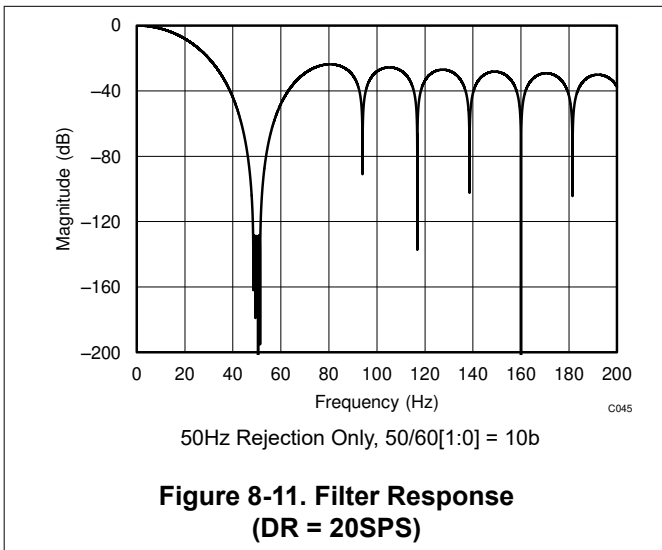
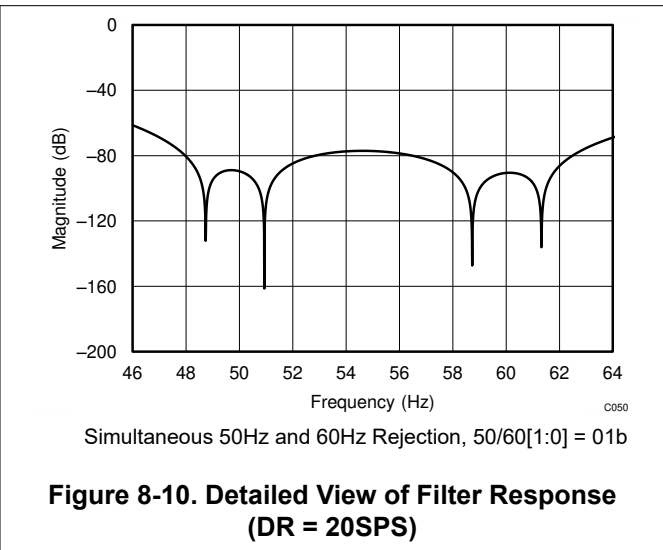
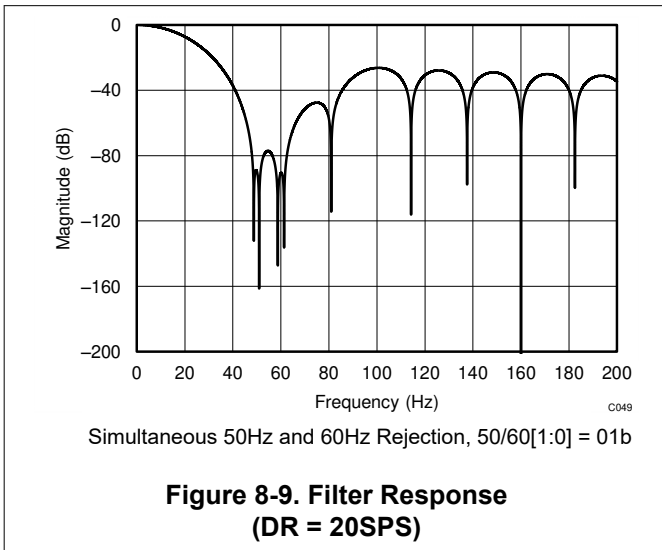
OPERATING MODE	$f_{\text{MOD}}$
Duty-cycle mode	256kHz
Normal mode	256kHz
Turbo mode	512kHz

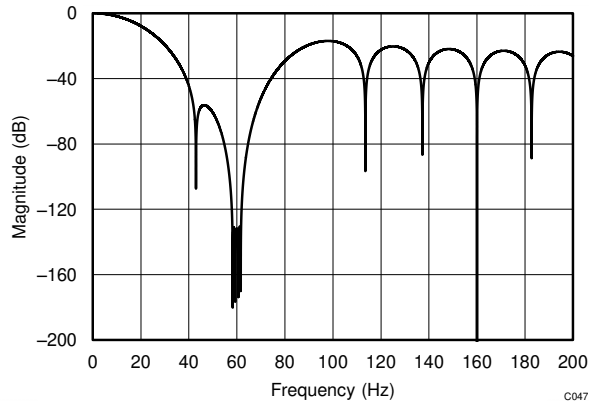
(1) Using the internal oscillator or an external 4.096MHz clock.

### 8.3.6 Digital Filter

The device uses a linear-phase finite impulse response (FIR) digital filter that performs both filtering and decimation of the digital data stream coming from the modulator. The digital filter is automatically adjusted for the different data rates and always settles within a single cycle. At data rates of 5SPS and 20SPS, use the 50/60[1:0] bits in the configuration register to select line frequency rejections of 50Hz or 60Hz or to simultaneously reject 50Hz and 60Hz. The frequency responses of the digital filter are illustrated in [Figure 8-9](#) to [Figure 8-22](#) for different output data rates using the internal oscillator or an external 4.096MHz clock.

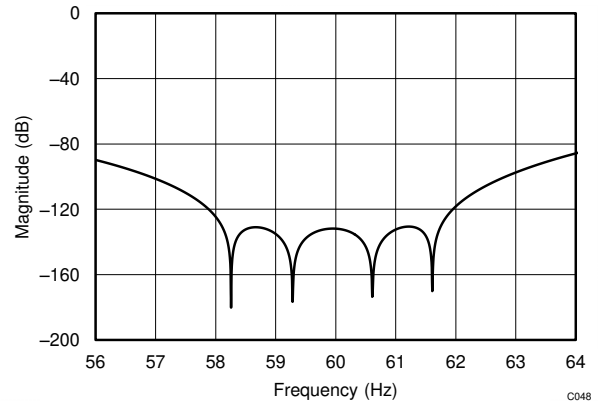
The filter notches and output data rate scale proportionally with the clock frequency. For example, a notch that appears at 20Hz when using a 4.096MHz clock appears at 10Hz if a 2.048MHz clock is used. The internal oscillator can vary over temperature as specified in the [Electrical Characteristics](#) table. The data rate or conversion time, respectively, and filter notches consequently vary by the same amount. Consider using an external precision clock source if a digital filter notch at a specific frequency with a tighter tolerance is required.





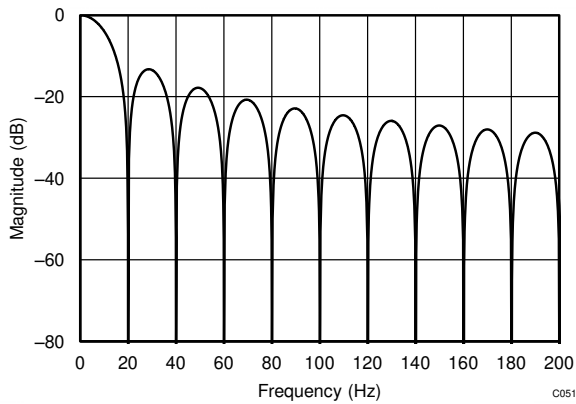
60Hz Rejection Only, 50/60[1:0] = 11b

**Figure 8-13. Filter Response  
(DR = 20SPS)**



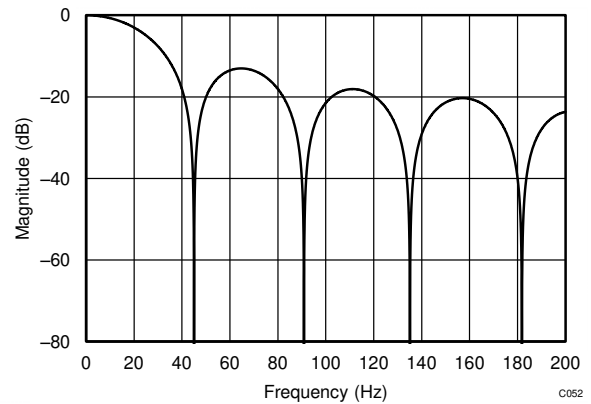
60Hz Rejection Only, 50/60[1:0] = 11b

**Figure 8-14. Detailed View of Filter Response  
(DR = 20SPS)**

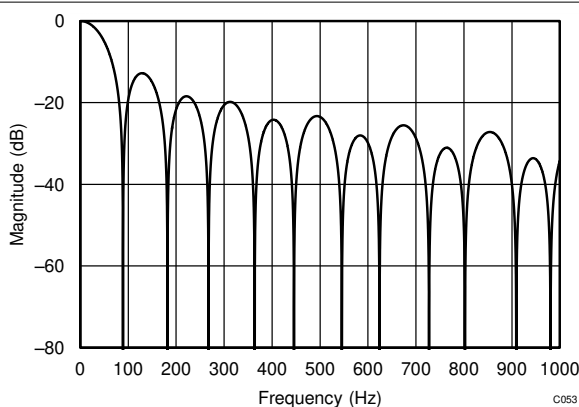


50/60[1:0] = 00b

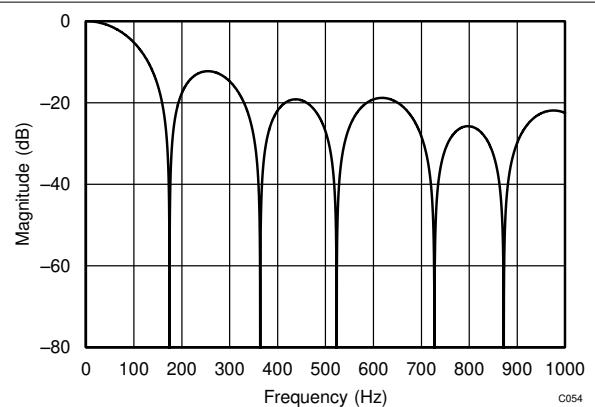
**Figure 8-15. Filter Response  
(DR = 20SPS)**



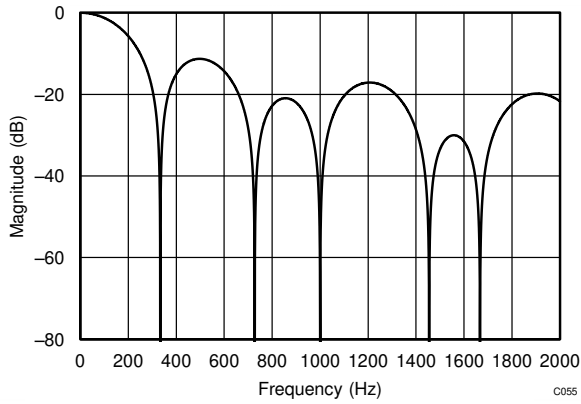
**Figure 8-16. Filter Response  
(DR = 45SPS)**



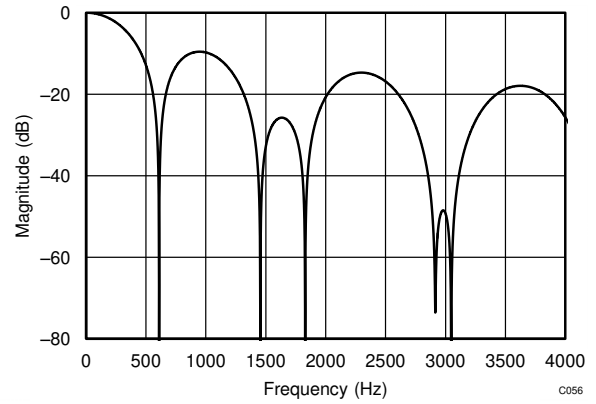
**Figure 8-17. Filter Response  
(DR = 90SPS)**



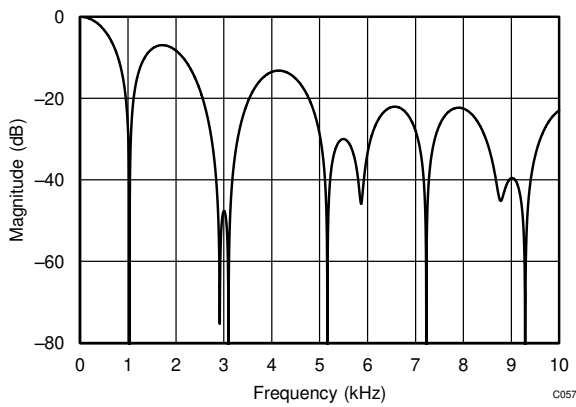
**Figure 8-18. Filter Response  
(DR = 175SPS)**



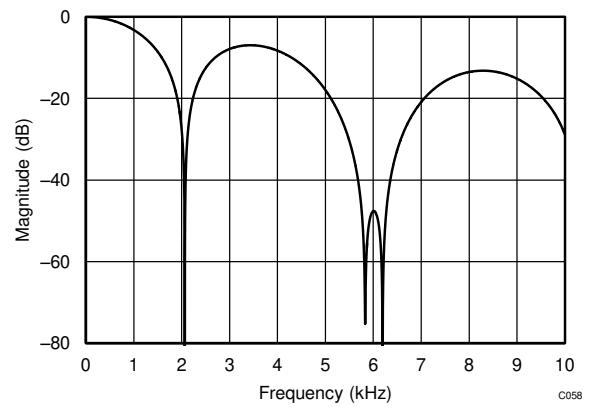
**Figure 8-19. Filter Response (DR = 330SPS)**



**Figure 8-20. Filter Response (DR = 600SPS)**



**Figure 8-21. Filter Response (DR = 1kSPS)**



**Figure 8-22. Filter Response (DR = 2kSPS)**

### 8.3.7 Output Data Rate

**Table 8-4** shows the actual conversion times for each data rate setting. The values provided are in terms of  $t_{\text{CLK}}$  cycles using an external clock with a clock frequency of  $f_{\text{CLK}} = 4.096\text{MHz}$ . The data rates scale proportionally in case an external clock with a frequency other than 4.096MHz is used.

Continuous-conversion mode data rates are timed from one  $\overline{\text{DRDY}}$  falling edge to the next  $\overline{\text{DRDY}}$  falling edge. The first conversion starts  $210 \times t_{\text{CLK}}$  (normal mode, duty-cycle mode) or  $114 \times t_{\text{CLK}}$  (turbo mode) after the last SCLK falling edge of the START/SYNC command.

Single-shot conversion mode data rates are timed from the last SCLK falling edge of the START/SYNC command to the  $\overline{\text{DRDY}}$  falling edge and rounded to the next  $t_{\text{CLK}}$ . In case the internal oscillator is used, an additional oscillator wake-up time of up to  $50\mu\text{s}$  (normal mode, duty-cycle mode) or  $25\mu\text{s}$  (turbo mode) must be added in single-shot conversion mode. The internal oscillator starts to power up at the first SCLK rising edge of the START/SYNC command. If an SCLK frequency higher than 160kHz (normal mode, duty-cycle mode) or 320kHz (turbo mode) is used, the oscillator is not always fully powered up at the end of the START/SYNC command. The ADC then waits until the internal oscillator is fully powered up before starting a conversion.

Single-shot conversion times in duty-cycle mode are the same as in normal mode. See the [Duty-Cycle Mode](#) section for more details on duty-cycle mode operation.

**Table 8-4. Conversion Times**

NOMINAL DATA RATE (SPS)	-3dB BANDWIDTH (Hz)	ACTUAL CONVERSION TIME ( $t_{\text{CLK}}$ )	
		CONTINUOUS CONVERSION MODE	SINGLE-SHOT CONVERSION MODE
<b>NORMAL MODE</b>			
20	13.1	204768	204850
45	20.0	91120	91218
90	39.6	46128	46226
175	77.8	23664	23762
330	150.1	12464	12562
600	279.0	6896	6994
1000	483.8	4144	4242
<b>DUTY-CYCLE MODE</b>			
5	13.1	823120	n/a
11.25	20.0	364560	n/a
22.5	39.6	184592	n/a
44	77.8	94736	n/a
82.5	150.1	49936	n/a
150	279.0	27664	n/a
250	483.8	16656	n/a
<b>TURBO MODE</b>			
40	17.1	102384	102434
90	39.9	45560	45618
180	79.2	23064	23122
350	155.6	11832	11890
660	300.3	6232	6290
1200	558.1	3448	3506
2000	967.6	2072	2130

Even though the conversion time at the 20SPS setting is not exactly  $1 / 20\text{Hz} = 50\text{ms}$ , this discrepancy does not affect the 50Hz or 60Hz rejection. To achieve the 50Hz and 60Hz rejection specified in the [Electrical Characteristics](#) table, the external clock frequency must be 4.096MHz. When using the internal oscillator, the conversion time and filter notches vary by the amount specified in the [Electrical Characteristics](#) table for oscillator accuracy.

### 8.3.8 Excitation Current Sources

The device provides two matched programmable excitation current sources (IDACs) for RTD applications. The output current of the current sources can be programmed to 10 $\mu$ A, 50 $\mu$ A, 100 $\mu$ A, 250 $\mu$ A, 500 $\mu$ A, 1000 $\mu$ A, or 1500 $\mu$ A using the respective bits (IDAC[2:0]) in the configuration register. Each current source can be connected to any of the analog inputs (AINx) as well as to any of the dedicated reference inputs (REFP0 and REFN0). Both current sources can also be connected to the same pin. Use the I1MUX[2:0] and I2MUX[2:0] bits in the configuration register to configure the routing of the IDACs. Care must be taken not to exceed the compliance voltage of the IDACs. In other words, limit the voltage on the pin where the IDAC is routed to  $\leq$  (AVDD – 0.9V), otherwise the specified accuracy of the IDAC current is not met. For three-wire RTD applications, the matched current sources can be used to cancel errors caused by sensor lead resistance (see the [3-Wire RTD Measurement](#) section for more details).

The IDACs require up to 200 $\mu$ s to start up after the IDAC current is programmed to the respective value using the IDAC[2:0] bits. Set the IDAC current to the respective value using the IDAC[2:0] bits and then select the routing for each IDAC (I1MUX[2:0], I2MUX[2:0]) thereafter.

In single-shot conversion mode, the IDACs remain active between any two conversions if the IDAC[2:0] bits are set to a value other than 000b. However, the IDACs are powered down whenever the POWERDOWN command is issued.

The analog supply current increases when enabling the IDACs (that is, when the IDAC[2:0] bits are set to a value other than 000b). The IDAC circuit needs this bias current to operate even when the IDACs are not routed to any pin (I1MUX[2:0] = I2MUX[2:0] = 000b). In addition, the selected output current is drawn from the analog supply when I1MUX[2:0] or I2MUX[2:0] are set to a value other than 000b.

### 8.3.9 Low-Side Power Switch

A low-side power switch with low on-resistance connected between the analog input AIN3/REFN1 and AVSS is integrated in the device as well. This power switch can be used to reduce system power consumption in bridge sensor applications by powering down the bridge circuit between conversions. When the respective bit (PSW) in the configuration register is set, the switch automatically closes when the START/SYNC command is sent and opens when the POWERDOWN command is issued. The switch stays closed between conversions in single-shot conversion mode in case the PSW bit is set to 1b. The switch can be opened at any time by setting the PSW bit to 0b. By default, the switch is always open.

### 8.3.10 Sensor Detection

To help detect a possible sensor malfunction, the device provides internal 10 $\mu$ A, burn-out current sources. When enabled by setting the respective bit (BCS) in the configuration register, one current source sources current to the positive analog input (AIN<sub>P</sub>) currently selected while the other current source sinks current from the selected negative analog input (AIN<sub>N</sub>).

In case of an open circuit in the sensor, these burn-out current sources pull the positive input towards AVDD and the negative input towards AVSS, resulting in a full-scale reading. A full-scale reading can also indicate that the sensor is overloaded or that the reference voltage is absent. A near-zero reading can indicate a shorted sensor. The absolute value of the burn-out current sources typically varies by  $\pm$ 10% and the internal multiplexer adds a small series resistance. Therefore, distinguishing a shorted sensor condition from a normal reading can be difficult, especially if an RC filter is used at the inputs. In other words, even if the sensor is shorted, the voltage drop across the external filter resistance and the residual resistance of the multiplexer causes the output to read a value higher than zero.

ADC readings of a functional sensor can be corrupted when the burn-out current sources are enabled. Disable the burn-out current sources when performing the precision measurement, and only enable these sources to test for sensor fault conditions.

### 8.3.11 System Monitor

The device provides some means for monitoring the analog power supply and the external voltage reference. To select a monitoring voltage, configure the internal multiplexer accordingly using the MUX[3:0] bits in the configuration register. The device automatically bypasses the PGA and sets the gain to 1, irrespective of the configuration register settings while the monitoring feature is used. The system monitor function only provides a coarse result and is not meant to be a precision measurement.

When measuring the analog power supply (MUX[3:0] = 1101b), the resulting conversion is approximately  $(AVDD - AVSS) / 4$ . The device uses the internal 2.048V reference for the measurement regardless of what reference source is selected in the configuration register (VREF[1:0]).

When monitoring one of the two possible external reference voltage sources (MUX[3:0] = 1100b), the result is approximately  $(V_{REFPx} - V_{REFNx}) / 4$ . REFPx and REFNx denote the external reference input pair selected in the configuration register (VREF[1:0]). The device automatically uses the internal reference for the measurement.

### 8.3.12 Offset Calibration

The internal multiplexer offers the option to short both PGA inputs ( $AIN_P$  and  $AIN_N$ ) to mid-supply  $(AVDD + AVSS) / 2$ . This option can be used to measure and calibrate the device offset voltage by storing the result of the shorted input voltage reading in a microcontroller and consequently subtracting the result from each following reading. Take multiple readings with the inputs shorted and average the result to reduce the effect of noise.

### 8.3.13 Temperature Sensor

The ADS1220 offers an integrated precision temperature sensor. The temperature sensor mode is enabled by setting bit TS = 1b in the configuration register. When in temperature sensor mode, the settings of [configuration register 0](#) have no effect and the device uses the internal reference for measurement, regardless of the selected voltage reference source. Temperature readings follow the same process as the analog inputs for starting and reading conversion results. Temperature data are represented as a 14-bit result that is left-justified within the 24-bit conversion data. Data are output starting with the most significant byte (MSB). When reading the three data bytes, the first 14 bits are used to indicate the temperature measurement result. One 14-bit LSB equals 0.03125°C. Negative numbers are represented in binary two's complement format, as shown in [Table 8-5](#).

**Table 8-5. 14-Bit Temperature Data Format**

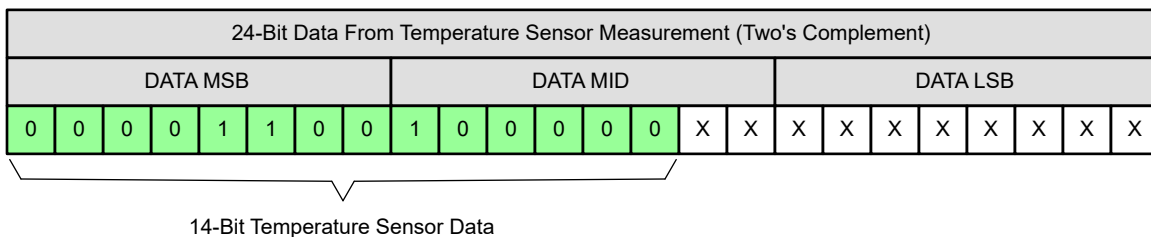
TEMPERATURE (°C)	DIGITAL OUTPUT (BINARY)	HEX
128	01 0000 0000 0000b	1000h
127.96875	00 1111 1111 1111b	0FFFh
100	00 1100 1000 0000b	0C80h
75	00 1001 0110 0000b	0960h
50	00 0110 0100 0000b	0640h
25	00 0011 0010 0000b	0320h
0.25	00 0000 0000 1000b	0008h
0.03125	00 0000 0000 0001b	0001h
0	00 0000 0000 0000b	0000h
-0.25	11 1111 1111 1000b	3FF8h
-25	11 1100 1110 0000b	3CE0h
-40	11 1011 0000 0000b	3B00h

#### 8.3.13.1 Converting From Digital Codes to Temperature

To convert from digital codes to temperature, first read the data bytes from the device and extract the 14-bit temperature value by right-shifting the result. [Figure 8-23](#) shows the 14-bit temperature sensor data alignment within the 24-bit conversion result. The MSB of the 14-bit value determines the sign: 0b indicates a positive temperature and 1b indicates a negative temperature. For positive temperatures convert the 14-bit binary value to decimal and multiply the result by the temperature sensor LSB size, 0.03125°C. For negative temperatures, the value is in two's complement format. Invert all 14 bits and add 1b, convert to decimal, and multiply the result by the negative temperature sensor LSB size, -0.03125°C.

1. Positive temperature example: The device reads back 0960h:  $0960h \times 0.03125^\circ C = 2400 \times 0.03125^\circ C = 75^\circ C$

2. Negative temperature example: The device reads back 3CE0h: Subtract 1b and complement the result:  $3CE0h \rightarrow 0320h$ ,  $0320h \times (-0.03125^\circ C) = 800 \times (-0.03125^\circ C) = -25^\circ C$



**Figure 8-23. 14-Bit Temperature Sensor Data Alignment Within 24-Bit Conversion Result**

## 8.4 Device Functional Modes

### 8.4.1 Power-Up and Reset

When the device powers up, a reset is performed. The reset process takes approximately 50 $\mu$ s. After this power-up reset time, all internal circuitry (including the voltage reference) are stable and communication with the device is possible. As part of the reset process, the device sets all bits in the configuration registers to the respective default settings. By default, the device is set to single-shot conversion mode. After power-up, the device performs a single conversion using the default register settings and then enters a low-power state. When the conversion is complete, the  $\overline{\text{DRDY}}$  pin transitions from high to low. The high-to-low transition of the  $\overline{\text{DRDY}}$  pin can be used to signal that the ADS1220 is operational and ready to use. The power-up behavior is intended to prevent systems with tight power-supply requirements from encountering a current surge during power-up.

### 8.4.2 Conversion Modes

The device can be operated in one of two conversion modes that can be selected by the CM bit in the configuration register. These conversion modes are single-shot and continuous-conversion mode.

#### 8.4.2.1 Single-Shot Conversion Mode

In single-shot conversion mode, the device only performs a conversion when a START/SYNC command is issued. The device consequently performs one single conversion and returns to a low-power state afterwards. The internal oscillator and all analog circuitry (except for the excitation current sources) are turned off while the device waits in this low-power state until the next conversion is started. In addition, every write access to any configuration register also starts a new conversion. Writing to any configuration register while a conversion is ongoing functions as a new START/SYNC command that stops the current conversion and restarts a single new conversion. Each conversion is fully settled (assuming the analog input signal settles to the final value before the conversion starts) because the device digital filter settles within a single cycle.

#### 8.4.2.2 Continuous Conversion Mode

In continuous conversion mode, the device continuously performs conversions. When a conversion completes, the device places the result in the output buffer and immediately begins another conversion.

To start continuous conversion mode, the CM bit must be set to 1b followed by a START/SYNC command. The first conversion starts  $210 \times t_{\text{CLK}}$  (normal mode, duty-cycle mode) or  $114 \times t_{\text{CLK}}$  (turbo mode) after the last SCLK falling edge of the START/SYNC command. Writing to any configuration register during an ongoing conversion restarts the current conversion. Send a START/SYNC command immediately after the CM bit is set to 1b.

### 8.4.3 Operating Modes

In addition to the different conversion modes, the device can also be operated in different operating modes that can be selected to trade-off power consumption, noise performance, and output data rate. These modes are: normal mode, duty-cycle mode, turbo mode, and power-down mode.

#### 8.4.3.1 Normal Mode

Normal mode is the default mode of operation after power-up. In this mode, the internal modulator of the  $\Delta\Sigma$  ADC runs at a modulator clock frequency of  $f_{\text{MOD}} = f_{\text{CLK}} / 16$ , where the system clock ( $f_{\text{CLK}}$ ) is either provided by the internal oscillator or the external clock source. The modulator frequency is 256kHz when using the internal oscillator. Normal mode offers output data rate options ranging from 20SPS to 1kSPS with the internal oscillator. The data rate is selected by the DR[2:0] bits in the configuration register. In case an external clock source with a clock frequency other than 4.096MHz is used, the data rates scale accordingly. For example, using an external clock with  $f_{\text{CLK}} = 2.048\text{MHz}$  yields data rates ranging from 10SPS to 500SPS.

#### 8.4.3.2 Duty-Cycle Mode

The noise performance of a  $\Delta\Sigma$  ADC generally improves when lowering the output data rate because more samples of the internal modulator can be averaged to yield one conversion result. In applications where power consumption is critical, the improved noise performance at low data rates are not always required. For these applications, the device supports an automatic duty-cycle mode that can yield significant power savings by periodically entering a low-power state between conversions. In principle, the device runs in normal mode with a duty cycle of 25%. This functionality means the device performs one conversion in the same manner as when running in normal mode but then automatically enters a low power-state for three consecutive conversion cycles. The noise performance in duty-cycle mode is therefore comparable to the noise performance in normal mode at four times the data rate. Data rates in duty-cycle mode range from 5SPS to 250SPS with the internal oscillator.

#### 8.4.3.3 Turbo Mode

Applications that require higher data rates up to 2kSPS can operate the device in turbo mode. In this mode, the internal modulator runs at a higher frequency of  $f_{\text{MOD}} = f_{\text{CLK}} / 8$ .  $f_{\text{MOD}}$  equals 512kHz when the internal oscillator or an external 4.096MHz clock is used. The device power consumption increases because the modulator runs at a higher frequency. Running the ADS1220 in turbo mode at a comparable output data rate as in normal mode yields better noise performance. For example, the input-referred noise at 90SPS in turbo mode is lower than the input-referred noise at 90SPS in normal mode.

#### 8.4.3.4 Power-Down Mode

When the POWERDOWN command is issued, the device enters power-down mode after completing the current conversion. In this mode, all analog circuitry (including the voltage reference and both IDACs) are powered down, the low-side power switch is opened, and the device typically only uses 400nA of current. While in power-down mode, the device holds the configuration register settings and responds to commands, but does not perform any data conversions.

Issuing a START/SYNC command wakes up the device and either starts a single conversion or starts continuous conversion mode, depending on the conversion mode selected by the CM bit. Writing to any configuration register wakes up the device as well, but only starts a single conversion regardless of the selected conversion mode (CM).

## 8.5 Programming

### 8.5.1 Serial Interface

The SPI-compatible serial interface of the device is used to read conversion data, read and write the device configuration registers, and control device operation. Only SPI mode 1 (CPOL = 0, CPHA = 1) is supported. The interface consists of five control lines ( $\overline{CS}$ , SCLK, DIN, DOUT/ $\overline{DRDY}$ , and  $\overline{DRDY}$ ) but can be used with only four or even three control signals as well. The dedicated data-ready signal ( $\overline{DRDY}$ ) can be configured to be shared with DOUT/ $\overline{DRDY}$ . If the serial bus is not shared with any other device,  $\overline{CS}$  can be tied low permanently so that only signals SCLK, DIN, and DOUT/ $\overline{DRDY}$  are required to communicate with the device.

#### 8.5.1.1 Chip Select ( $\overline{CS}$ )

Chip select ( $\overline{CS}$ ) is an active-low input that selects the device for SPI communication. This feature is useful when multiple devices share the same serial bus.  $\overline{CS}$  must remain low for the duration of the serial communication. When  $\overline{CS}$  is taken high, the serial interface is reset, SCLK is ignored, and DOUT/ $\overline{DRDY}$  enters a high-impedance state; as such, DOUT/ $\overline{DRDY}$  cannot indicate when data are ready. In situations where multiple devices are present on the bus, the dedicated  $\overline{DRDY}$  pin can provide an uninterrupted monitor of the conversion status. If the serial bus is not shared with another peripheral,  $\overline{CS}$  can be tied low.

#### 8.5.1.2 Serial Clock (SCLK)

The serial clock (SCLK) features a Schmitt-triggered input and is used to clock data into and out of the device on the DIN and DOUT/ $\overline{DRDY}$  pins, respectively. Even though the input has hysteresis, keep the SCLK signal as clean as possible to prevent glitches from accidentally shifting the data. When the serial interface is idle, hold SCLK low.

#### 8.5.1.3 Data Ready ( $\overline{DRDY}$ )

$\overline{DRDY}$  indicates when a new conversion result is ready for retrieval. When  $\overline{DRDY}$  falls low, new conversion data are ready.  $\overline{DRDY}$  transitions back high on the next SCLK rising edge. When no data are read during continuous conversion mode,  $\overline{DRDY}$  remains low but pulses high for a duration of  $2 \times t_{MOD}$  prior to the next  $\overline{DRDY}$  falling edge. The  $\overline{DRDY}$  pin is always actively driven, even when  $\overline{CS}$  is high.

#### 8.5.1.4 Data Input (DIN)

The data input pin (DIN) is used along with SCLK to send data (commands and register data) to the device. The device latches data on DIN on the SCLK falling edge. The device never drives the DIN pin.

#### 8.5.1.5 Data Output and Data Ready (DOUT/ $\overline{DRDY}$ )

DOUT/ $\overline{DRDY}$  serves a dual-purpose function. This pin is used with SCLK to read conversion and register data from the device. Data on DOUT/ $\overline{DRDY}$  are shifted out on the SCLK rising edge. DOUT/ $\overline{DRDY}$  goes to a high-impedance state when  $\overline{CS}$  is high.

In addition, the DOUT/ $\overline{DRDY}$  pin can also be configured as a data-ready indicator by setting the DRDYM bit high in the configuration register. DOUT/ $\overline{DRDY}$  then transitions low at the same time that the  $\overline{DRDY}$  pin goes low to indicate new conversion data are available. Both signals can be used to detect if new data are ready. However, because DOUT/ $\overline{DRDY}$  is disabled when  $\overline{CS}$  is high, the recommended method of monitoring the end of a conversion when multiple devices are present on the SPI bus is to use the dedicated  $\overline{DRDY}$  pin.

#### 8.5.1.6 SPI Timeout

The ADS1220 offers an SPI timeout feature that can be used to recover communication when a serial interface transmission is interrupted. This feature is especially useful in applications where  $\overline{CS}$  is permanently tied low and is not used to frame a communication sequence. Whenever a complete command is not sent within  $14000 \times t_{MOD}$  (normal mode, duty-cycle mode) or  $28000 \times t_{MOD}$  (turbo mode), the serial interface resets and the next SCLK pulse starts a new communication cycle. See the [Modulator](#) section for details on the modulator frequency ( $f_{MOD} = 1 / t_{MOD}$ ) in the different operating modes. For the RREG and WREG commands, a *complete command* includes the command byte plus the register bytes that are read or written.

### 8.5.2 Data Format

The device provides 24 bits of data in binary two's complement format. Use Equation 15 to calculate the size of one code (LSB).

$$1\text{LSB} = (2 \times V_{\text{REF}} / \text{Gain}) / 2^{24} = +\text{FS} / 2^{23} \quad (15)$$

A positive full-scale input [ $V_{\text{IN}} \geq (+\text{FS} - 1\text{LSB}) = (V_{\text{REF}} / \text{Gain} - 1\text{LSB})$ ] produces an output code of 7FFFFFFh and a negative full-scale input ( $V_{\text{IN}} \leq -\text{FS} = -V_{\text{REF}} / \text{Gain}$ ) produces an output code of 800000h. The output clips at these codes for signals that exceed full-scale.

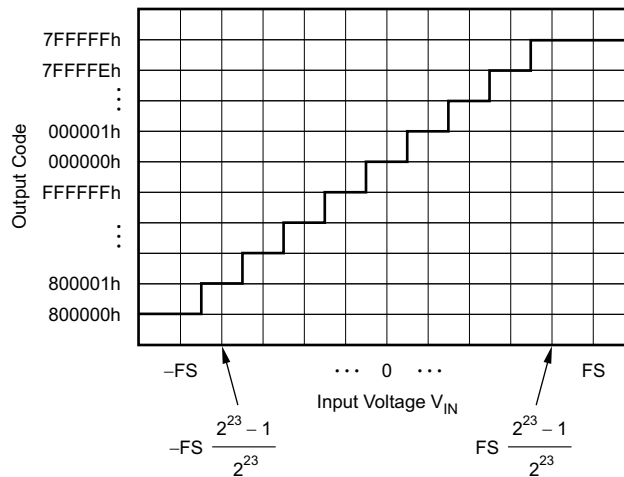
Table 8-6 summarizes the ideal output codes for different input signals.

**Table 8-6. Ideal Output Code versus Input Signal**

INPUT SIGNAL, $V_{\text{IN}}$ ( $\text{AIN}_P - \text{AIN}_N$ )	IDEAL OUTPUT CODE <sup>(1)</sup>
$\geq \text{FS} (2^{23} - 1) / 2^{23}$	7FFFFFFh
$\text{FS} / 2^{23}$	000001h
0	000000h
$-\text{FS} / 2^{23}$	FFFFFFh
$\leq -\text{FS}$	800000h

(1) Excludes the effects of noise, INL, offset, and gain errors.

Mapping of the analog input signal to the output codes is shown in Figure 8-24.



**Figure 8-24. Code Transition Diagram**

#### Note

Single-ended signal measurements, where  $V_{\text{AINN}} = 0\text{V}$  and  $V_{\text{AINP}} = 0\text{V}$  to  $+\text{FS}$ , only use the positive code range from 000000h to 7FFFFFFh. However, because of device offset, the ADS1220 can still output negative codes when  $V_{\text{AINP}}$  is close to 0V.

### 8.5.3 Commands

The device offers six different commands to control device operation, as shown in [Table 8-7](#). Four commands are stand-alone instructions (RESET, START/SYNC, POWERDOWN, and RDATA). The commands to read (RREG) and write (WREG) configuration register data from and to the device require additional information as part of the instruction.

**Table 8-7. Command Definitions**

COMMAND	DESCRIPTION	COMMAND BYTE <sup>(1)</sup>
RESET	Reset the device	0000 011xb
START/SYNC	Start or restart conversions	0000 100xb
POWERDOWN	Enter power-down mode	0000 001xb
RDATA	Read data by command	0001 xxxxb
RREG	Read <i>nn</i> registers starting at address <i>rr</i>	0010 <i>rrnbn</i>
WREG	Write <i>nn</i> registers starting at address <i>rr</i>	0100 <i>rrnbn</i>

(1) Operands: *rr* = configuration register (00b to 11b), *nn* = number of bytes – 1 (00b to 11b), and *x* = don't care.

#### 8.5.3.1 RESET (0000 011xb)

Resets the device to the default values. Wait at least ( $50\mu\text{s} + 32 \times t_{\text{CLK}}$ ) after the RESET command is sent before sending any other command.

#### 8.5.3.2 START/SYNC (0000 100xb)

In single-shot conversion mode, the START/SYNC command is used to start a single conversion, or (when sent during an ongoing conversion) to reset the digital filter, and then restarts a single new conversion. When the device is set to continuous conversion mode, the START/SYNC command must be issued one time to start converting continuously. Sending the START/SYNC command while converting in continuous-conversion mode resets the digital filter and restarts continuous conversions.

#### 8.5.3.3 POWERDOWN (0000 001xb)

The POWERDOWN command places the device into power-down mode. This command shuts down all internal analog components, opens the low-side switch, turns off both IDACs, but holds all register values. In case the POWERDOWN command is issued while a conversion is ongoing, the conversion completes before the ADS1220 enters power-down mode. As soon as a START/SYNC command is issued, all analog components return to the previous states.

#### 8.5.3.4 RDATA (0001 xxxxb)

The RDATA command loads the output shift register with the most recent conversion result. This command can be used when  $\overline{\text{DOUT}}/\overline{\text{DRDY}}$  or  $\overline{\text{DRDY}}$  are not monitored to indicate that a new conversion result is available. If a conversion finishes in the middle of the RDATA command byte, the state of the  $\overline{\text{DRDY}}$  pin at the end of the read operation signals whether the old or the new result is loaded. If the old result is loaded,  $\overline{\text{DRDY}}$  stays low, indicating that the new result is not read out. The new conversion result loads when  $\overline{\text{DRDY}}$  is high.

#### 8.5.3.5 RREG (0010 *rrnbn*)

The RREG command reads the number of bytes specified by *nn* (number of bytes to be read – 1) from the device configuration register, starting at register address *rr*. The command is completed after *nn* + 1 bytes are clocked out after the RREG command byte. For example, the command to read three bytes (*nn* = 10b) starting at configuration register 1 (*rr* = 01b) is 0010 0110b.

#### 8.5.3.6 WREG (0100 *rrnbn*)

The WREG command writes the number of bytes specified by *nn* (number of bytes to be written – 1) to the device configuration register, starting at register address *rr*. The command is completed after *nn* + 1 bytes are clocked in after the WREG command byte. For example, the command to write two bytes (*nn* = 01b) starting at configuration register 0 (*rr* = 00b) is 0100 0001b. The configuration registers are updated on the last SCLK falling edge.

### 8.5.4 Reading Data

Output pins  $\overline{\text{DRDY}}$  and  $\text{DOUT}/\overline{\text{DRDY}}$  (if the  $\text{DRDYM}$  bit is set high in the configuration register) transition low when new data are ready for retrieval. The conversion data are written to an internal data buffer. Data can be read directly from this buffer on  $\text{DOUT}/\overline{\text{DRDY}}$  when  $\overline{\text{DRDY}}$  falls low without concern of data corruption. An  $\text{RDATA}$  command does not have to be sent. Data are shifted out on the  $\text{SCLK}$  rising edges, MSB first, and consist of three bytes of data.

Figure 8-25 to Figure 8-27 show the timing diagrams for reading conversion data in continuous conversion mode and single-shot conversion mode when not using the  $\text{RDATA}$  command.

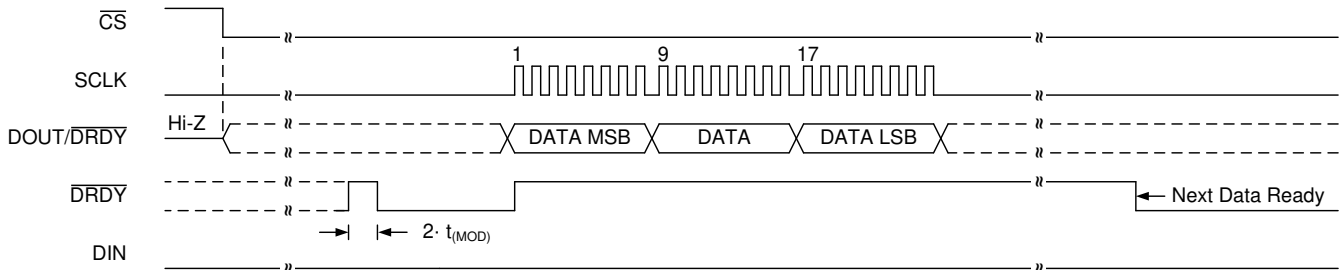


Figure 8-25. Continuous Conversion Mode ( $\text{DRDYM} = 0\text{b}$ )

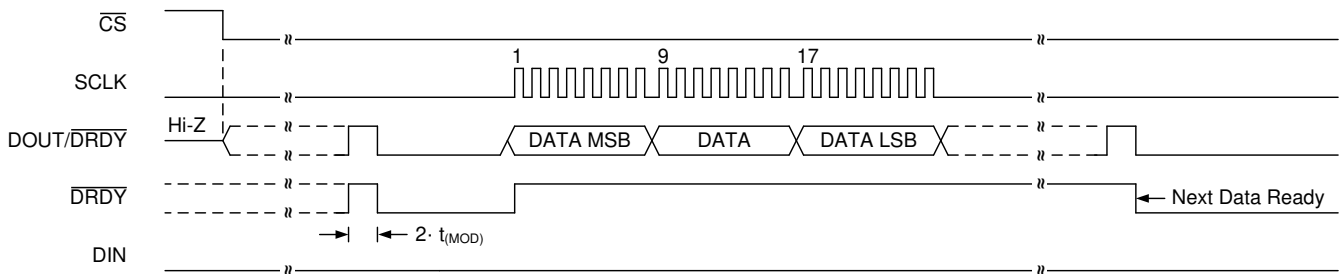


Figure 8-26. Continuous Conversion Mode ( $\text{DRDYM} = 1\text{b}$ )

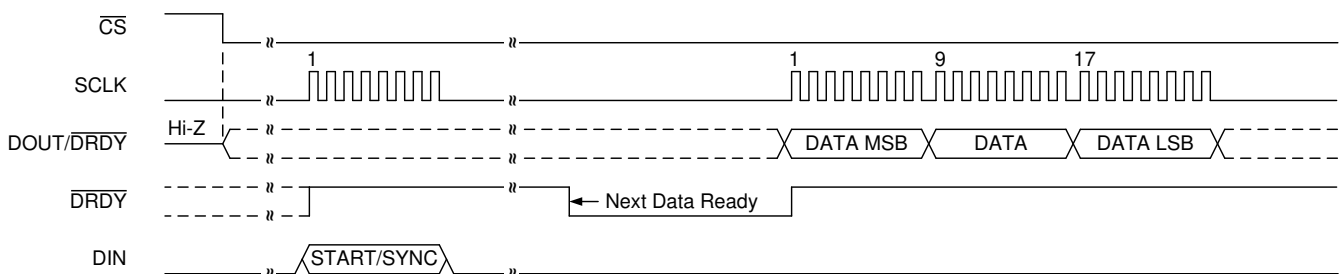
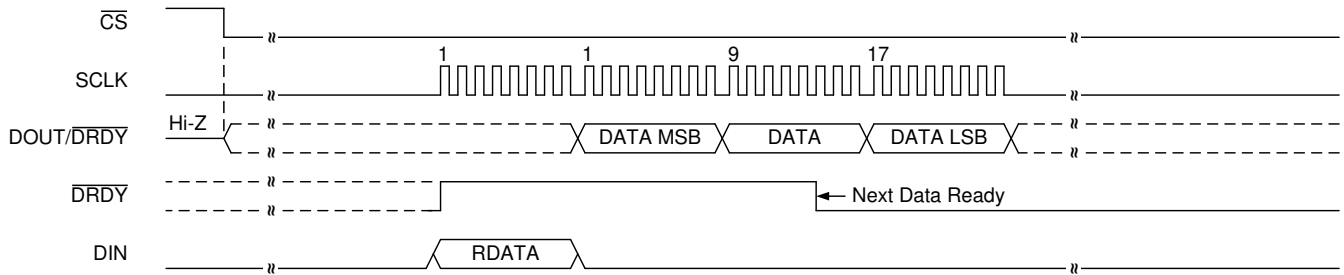
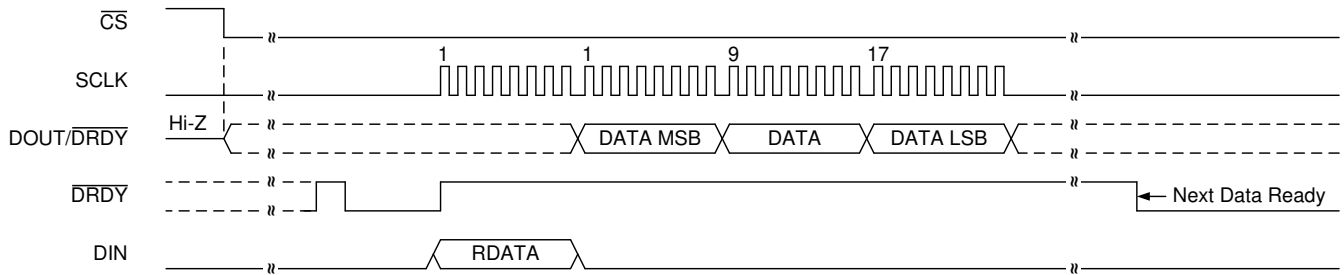


Figure 8-27. Single-Shot Conversion Mode ( $\text{DRDYM} = 0\text{b}$ )

Data can also be read at any time without synchronizing to the  $\overline{\text{DRDY}}$  signal using the  $\text{RDATA}$  command. When an  $\text{RDATA}$  command is issued, the conversion result currently stored in the data buffer is shifted out on  $\text{DOUT}/\overline{\text{DRDY}}$  on the following  $\text{SCLK}$  rising edges. Data can be read continuously with the  $\text{RDATA}$  command as an alternative to monitoring  $\overline{\text{DRDY}}$  or  $\text{DOUT}/\overline{\text{DRDY}}$ . The  $\overline{\text{DRDY}}$  pin can be polled after the LSB is clocked out to determine if a new conversion result is loaded. If a new conversion completes during the read operation but data from the previous conversion are read, then  $\overline{\text{DRDY}}$  is low. Otherwise, if the most recent result is read,  $\overline{\text{DRDY}}$  is high. Figure 8-28 and Figure 8-29 illustrate the behavior for both cases.



**Figure 8-28. State of DRDY When a New Conversion Finishes During an RDATA Command**

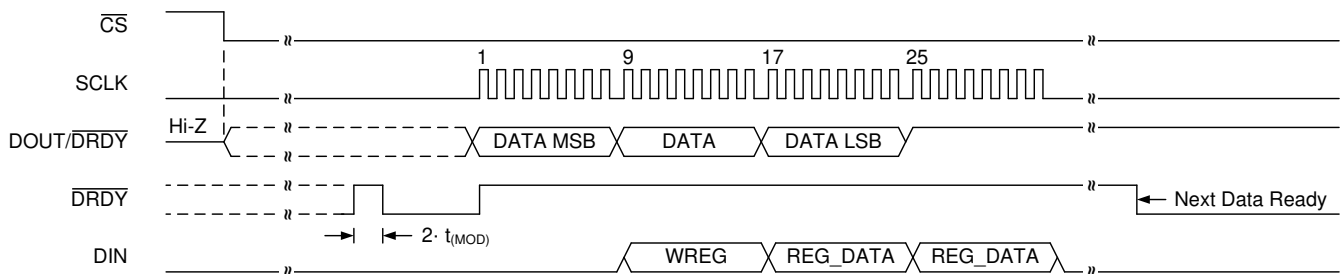


**Figure 8-29. State of DRDY When the Most Recent Conversion Result is Read During an RDATA Command**

### 8.5.5 Sending Commands

The device serial interface is capable of full-duplex operation while reading conversion data when not using the RDATA command. Full-duplex operation means commands are decoded at the same time that conversion data are read. Commands can be sent on any 8-bit data boundary during a data read operation. When a RREG or RDATA command is recognized, the current data read operation is aborted and the conversion data are corrupted, unless the command is sent while the last byte of the conversion result is retrieved. The device starts to output the requested data on DOUT/DRDY at the first SCLK rising edge after the command byte. To read data without interruption, keep DIN low while clocking out data.

A WREG command can be sent without corrupting an ongoing read operation. Figure 8-30 shows an example for sending a WREG command to write two configuration registers while reading conversion data in continuous conversion mode. After the command is clocked in (after the 32nd SCLK falling edge), the device resets the digital filter and starts converting with the new register settings. The WREG command can be sent on any of the 8-bit boundaries.



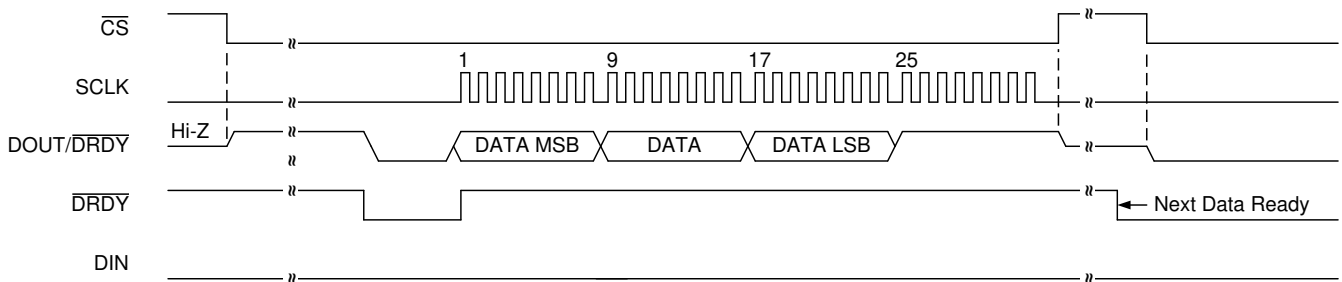
**Figure 8-30. Example of Reading Data while Simultaneously Sending a WREG Command**

The serial interface does not decode commands while an RDATA or RREG command is executed. That is, all 24 bits of the conversion result must be read after the RDATA command is issued and all requested registers must be read after a RREG command is sent before a new command can be issued.

### 8.5.6 Interfacing with Multiple Devices

When connecting multiple ADS1220 devices to a single SPI bus, SCLK, DIN, and DOUT/ $\overline{\text{DRDY}}$  can be safely shared by using a dedicated chip-select ( $\overline{\text{CS}}$ ) line for each SPI-enabled device. When  $\overline{\text{CS}}$  transitions high for the respective device, DOUT/ $\overline{\text{DRDY}}$  enters a 3-state mode. Therefore, DOUT/ $\overline{\text{DRDY}}$  cannot be used to indicate when new data are available if  $\overline{\text{CS}}$  is high, regardless of the DRDYM bit setting in the configuration register. Only the dedicated  $\overline{\text{DRDY}}$  pin indicates that new data are available, because the  $\overline{\text{DRDY}}$  pin is actively driven even when  $\overline{\text{CS}}$  is high.

In some cases the  $\overline{\text{DRDY}}$  pin cannot be interfaced to the microcontroller. This scenario can occur if there are insufficient GPIO channels available on the microcontroller or if the serial interface must be galvanically isolated and thus the amount of channels must be limited. Therefore, to evaluate when a new conversion of one of the devices is ready, the microcontroller can periodically drop  $\overline{\text{CS}}$  to the respective device and poll the state of the DOUT/ $\overline{\text{DRDY}}$  pin. When  $\overline{\text{CS}}$  goes low, the DOUT/ $\overline{\text{DRDY}}$  pin immediately drives either high or low, provided that the DRDYM bit is configured to 1b. If the DOUT/ $\overline{\text{DRDY}}$  line drives low, when  $\overline{\text{CS}}$  is taken low, new data are currently available. If the DOUT/ $\overline{\text{DRDY}}$  line drives high, no new data are available. This procedure requires that DOUT/ $\overline{\text{DRDY}}$  is high after reading each conversion result and before taking  $\overline{\text{CS}}$  high. To make sure DOUT/ $\overline{\text{DRDY}}$  is taken high, send 8 additional SCLKs with DIN held low after each data read operation. DOUT/ $\overline{\text{DRDY}}$  reads high during the eight SCLKs after the conversion result is read, as shown in Figure 8-31. Alternatively, valid data can be retrieved from the device at any time without concern of data corruption by using the RDATA command.



**Figure 8-31. Example of Taking DOUT/ $\overline{\text{DRDY}}$  High After Reading a Conversion Result**

## 8.6 Register Map

### 8.6.1 Configuration Registers

The device has four 8-bit configuration registers that are accessible through the serial interface using the RREG and WREG commands. After power-up or reset, all registers are set to the default values (which are all 00h). All registers retain the values during power-down mode. [Table 8-8](#) shows the register map of the configuration registers.

**Table 8-8. Configuration Register Map**

REGISTER (Hex)	BIT 7	BIT 6	BIT 5	BIT 4	BIT 3	BIT 2	BIT 1	BIT 0
00h	MUX[3:0]			GAIN[2:0]			PGA_BYPASS	
01h	DR[2:0]		MODE[1:0]		CM	TS	BCS	
02h	VREF[1:0]		50/60[1:0]		PSW	IDAC[2:0]		
03h	I1MUX[2:0]			I2MUX[2:0]			DRDYM	RESERVED

### 8.6.2 Register Descriptions

[Table 8-9](#) lists the access codes for the ADS1220 registers.

**Table 8-9. Register Access Type Codes**

Access Type	Code	Description
R	R	Read
R/W	R/W	Read-Write
W	W	Write
-n		Value after reset or the default value

8.6.2.1 Configuration Register 0 (Address = 00h) [reset = 00h]

Figure 8-32. Configuration Register 0

7	6	5	4	3	2	1	0
MUX[3:0]				GAIN[2:0]			PGA_BYPASS
R/W-0000b				R/W-000b			R/W-0b

Table 8-10. Configuration Register 0 Field Descriptions

Bit	Field	Type	Reset	Description
7:4	MUX[3:0]	R/W	0000b	<p><b>Input multiplexer configuration</b> These bits configure the input multiplexer. For settings where <math>AIN_N = AVSS</math>, the PGA must be disabled (<math>PGA\_BYPASS = 1</math>) and only gains 1, 2, and 4 can be used.</p> <p>0000b : <math>AIN_P = AIN_0, AIN_N = AIN_1</math>            0001b : <math>AIN_P = AIN_0, AIN_N = AIN_2</math>            0010b : <math>AIN_P = AIN_0, AIN_N = AIN_3</math>            0011b : <math>AIN_P = AIN_1, AIN_N = AIN_2</math>            0100b : <math>AIN_P = AIN_1, AIN_N = AIN_3</math>            0101b : <math>AIN_P = AIN_2, AIN_N = AIN_3</math>            0110b : <math>AIN_P = AIN_1, AIN_N = AIN_0</math>            0111b : <math>AIN_P = AIN_3, AIN_N = AIN_2</math>            1000b : <math>AIN_P = AIN_0, AIN_N = AVSS</math>            1001b : <math>AIN_P = AIN_1, AIN_N = AVSS</math>            1010b : <math>AIN_P = AIN_2, AIN_N = AVSS</math>            1011b : <math>AIN_P = AIN_3, AIN_N = AVSS</math>            1100b : <math>(V_{REFPX} - V_{REFNX}) / 4</math> monitor (PGA bypassed)            1101b : <math>(AVDD - AVSS) / 4</math> monitor (PGA bypassed)            1110b : <math>AIN_P</math> and <math>AIN_N</math> shorted to <math>(AVDD + AVSS) / 2</math>            1111b : Reserved</p>
3:1	GAIN[2:0]	R/W	000b	<p><b>Gain configuration</b> These bits configure the device gain. Gains 1, 2, and 4 can be used without the PGA. In this case, gain is obtained by a switched-capacitor structure.</p> <p>000b : Gain = 1            001b : Gain = 2            010b : Gain = 4            011b : Gain = 8            100b : Gain = 16            101b : Gain = 32            110b : Gain = 64            111b : Gain = 128</p>
0	PGA_BYPASS	R/W	0b	<p><b>Disables and bypasses the internal low-noise PGA</b> Disabling the PGA reduces overall power consumption and allows the common-mode voltage range (<math>V_{CM}</math>) to span from <math>AVSS - 0.1V</math> to <math>AVDD + 0.1V</math>. The PGA can only be disabled for gains 1, 2, and 4. The PGA is always enabled for gain settings 8 to 128, regardless of the <math>PGA\_BYPASS</math> setting.</p> <p>0b : PGA enabled            1b : PGA disabled and bypassed</p>

8.6.2.2 Configuration Register 1 (Address = 01h) [reset = 00h]

Figure 8-33. Configuration Register 1

7	6	5	4	3	2	1	0
DR[2:0]		MODE[1:0]		CM	TS	BCS	
R/W-000b		R/W-00b		R/W-0b	R/W-0b	R/W-0b	

Table 8-11. Configuration Register 1 Field Descriptions

Bit	Field	Type	Reset	Description
7:5	DR[2:0]	R/W	000b	<b>Data rate</b> These bits control the data rate setting depending on the selected operating mode. Table 8-12 lists the bit settings for normal, duty-cycle, and turbo mode.
4:3	MODE[1:0]	R/W	00b	<b>Operating mode</b> These bits control the operating mode the device operates in. 00b : Normal mode (256kHz modulator clock) 01b : Duty-cycle mode (internal duty cycle of 1:4) 10b : Turbo mode (512kHz modulator clock) 11b : Reserved
2	CM	R/W	0b	<b>Conversion mode</b> This bit sets the conversion mode for the device. 0b : Single-shot conversion mode 1b : Continuous conversion mode
1	TS	R/W	0b	<b>Temperature sensor mode</b> This bit enables the internal temperature sensor and puts the device in temperature sensor mode. The settings of configuration register 0 have no effect and the device uses the internal reference for measurement when temperature sensor mode is enabled. 0b : Disables temperature sensor 1b : Enables temperature sensor
0	BCS	R/W	0b	<b>Burn-out current sources</b> This bit controls the 10µA, burn-out current sources. The burn-out current sources can be used to detect sensor faults such as wire breaks and shorted sensors. 0b : Current sources off 1b : Current sources on

Table 8-12. DR Bit Settings <sup>(1)</sup>

NORMAL MODE	DUTY-CYCLE MODE	TURBO MODE
000b = 20SPS	000b = 5SPS	000b = 40SPS
001b = 45SPS	001b = 11.25SPS	001b = 90SPS
010b = 90SPS	010b = 22.5SPS	010b = 180SPS
011b = 175SPS	011b = 44SPS	011b = 350SPS
100b = 330SPS	100b = 82.5SPS	100b = 660SPS
101b = 600SPS	101b = 150SPS	101b = 1200SPS
110b = 1000SPS	110b = 250SPS	110b = 2000SPS
111b = Reserved	111b = Reserved	111b = Reserved

(1) Data rates provided are calculated using the internal oscillator or an external 4.096MHz clock. The data rates scale proportionally with the external clock frequency when an external clock other than 4.096MHz is used.

### 8.6.2.3 Configuration Register 2 (Address = 02h) [reset = 00h]

**Figure 8-34. Configuration Register 2**

7	6	5	4	3	2	1	0
VREF[1:0]	50/60[1:0]		PSW	IDAC[2:0]			
R/W-00b	R/W-00b		R/W-0b	R/W-000b			

**Table 8-13. Configuration Register 2 Field Descriptions**

Bit	Field	Type	Reset	Description
7:6	VREF[1:0]	R/W	00b	<b>Voltage reference selection</b> These bits select the voltage reference source that is used for the conversion. 00b : Internal 2.048V reference selected 01b : External reference selected using dedicated REFP0 and REFN0 inputs 10b : External reference selected using AIN0/REFP1 and AIN3/REFN1 inputs 11b : Analog supply (AVDD – AVSS) used as reference
5:4	50/60[1:0]	R/W	00b	<b>FIR filter configuration</b> These bits configure the filter coefficients for the internal FIR filter. Only use these bits together with the 20SPS setting in normal mode and the 5SPS setting in duty-cycle mode. Set to 00b for all other data rates. 00b : No 50Hz or 60Hz rejection 01b : Simultaneous 50Hz and 60Hz rejection 10b : 50Hz rejection only 11b : 60Hz rejection only
3	PSW	R/W	0h	<b>Low-side power switch configuration</b> This bit configures the behavior of the low-side switch connected between AIN3/REFN1 and AVSS. 0b : Switch is always open 1b : Switch automatically closes when the START/SYNC command is sent and opens when the POWERDOWN command is issued
2:0	IDAC[2:0]	R/W	0h	<b>IDAC current setting</b> These bits set the current for both IDAC1 and IDAC2 excitation current sources. 000b : Off 001b : 10µA 010b : 50µA 011b : 100µA 100b : 250µA 101b : 500µA 110b : 1000µA 111b : 1500µA

8.6.2.4 Configuration Register 3 (Address = 03h) [reset = 00h]

Figure 8-35. Configuration Register 3

7	6	5	4	3	2	1	0
I1MUX[2:0]			I2MUX[2:0]			DRDYM	RESERVED
R/W-000b			R/W-000b			R/W-0b	R/W-0b

Table 8-14. Configuration Register 3 Field Descriptions

Bit	Field	Type	Reset	Description
7:5	I1MUX[2:0]	R/W	000b	<b>IDAC1 routing configuration</b> These bits select the channel where IDAC1 is routed to. 000b : IDAC1 disabled 001b : IDAC1 connected to AIN0/REFP1 010b : IDAC1 connected to AIN1 011b : IDAC1 connected to AIN2 100b : IDAC1 connected to AIN3/REFN1 101b : IDAC1 connected to REFPO 110b : IDAC1 connected to REFNO 111b : Reserved
4:2	I2MUX[2:0]	R/W	000b	<b>IDAC2 routing configuration</b> These bits select the channel where IDAC2 is routed to. 000b : IDAC2 disabled 001b : IDAC2 connected to AIN0/REFP1 010b : IDAC2 connected to AIN1 011b : IDAC2 connected to AIN2 100b : IDAC2 connected to AIN3/REFN1 101b : IDAC2 connected to REFPO 110b : IDAC2 connected to REFNO 111b : Reserved
1	DRDYM	R/W	0b	<b>DRDY mode</b> This bit controls the behavior of the DOUT/ $\overline{\text{DRDY}}$ pin when new data are ready. 0b : Only the dedicated $\overline{\text{DRDY}}$ pin is used to indicate when data are ready 1b : Data ready is indicated simultaneously on DOUT/ $\overline{\text{DRDY}}$ and DRDY
0	RESERVED	R/W	0b	<b>Reserved</b> Always write 0b

## 9 Application and Implementation

### Note

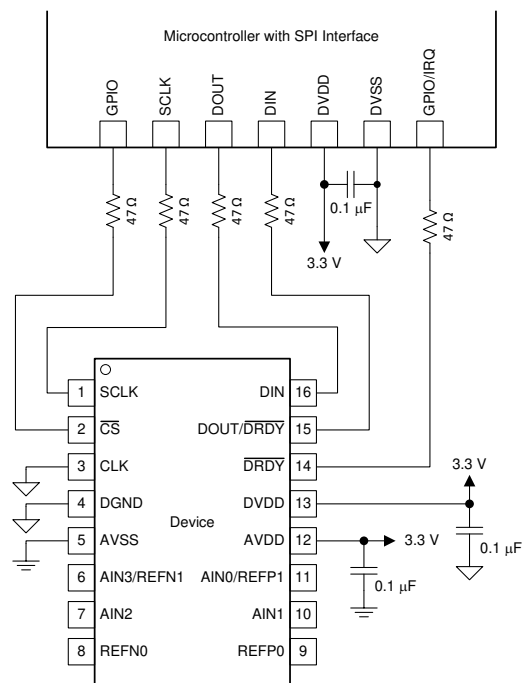
Information in the following applications sections is not part of the TI component specification, and TI does not warrant its accuracy or completeness. TI's customers are responsible for determining suitability of components for their purposes, as well as validating and testing their design implementation to confirm system functionality.

### 9.1 Application Information

The ADS1220 is a precision, 24-bit,  $\Delta\Sigma$  ADC that offers many integrated features to ease the measurement of the most common sensor types including various types of temperature and bridge sensors. Primary considerations when designing an application with the ADS1220 include analog input filtering, establishing an appropriate external reference for ratiometric measurements, and setting the common-mode input voltage for the internal PGA. Connecting and configuring the serial interface appropriately is another concern. These considerations are discussed in the following sections.

#### 9.1.1 Serial Interface Connections

The principle serial interface connections for the ADS1220 are shown in [Figure 9-1](#).



**Figure 9-1. Serial Interface Connections**

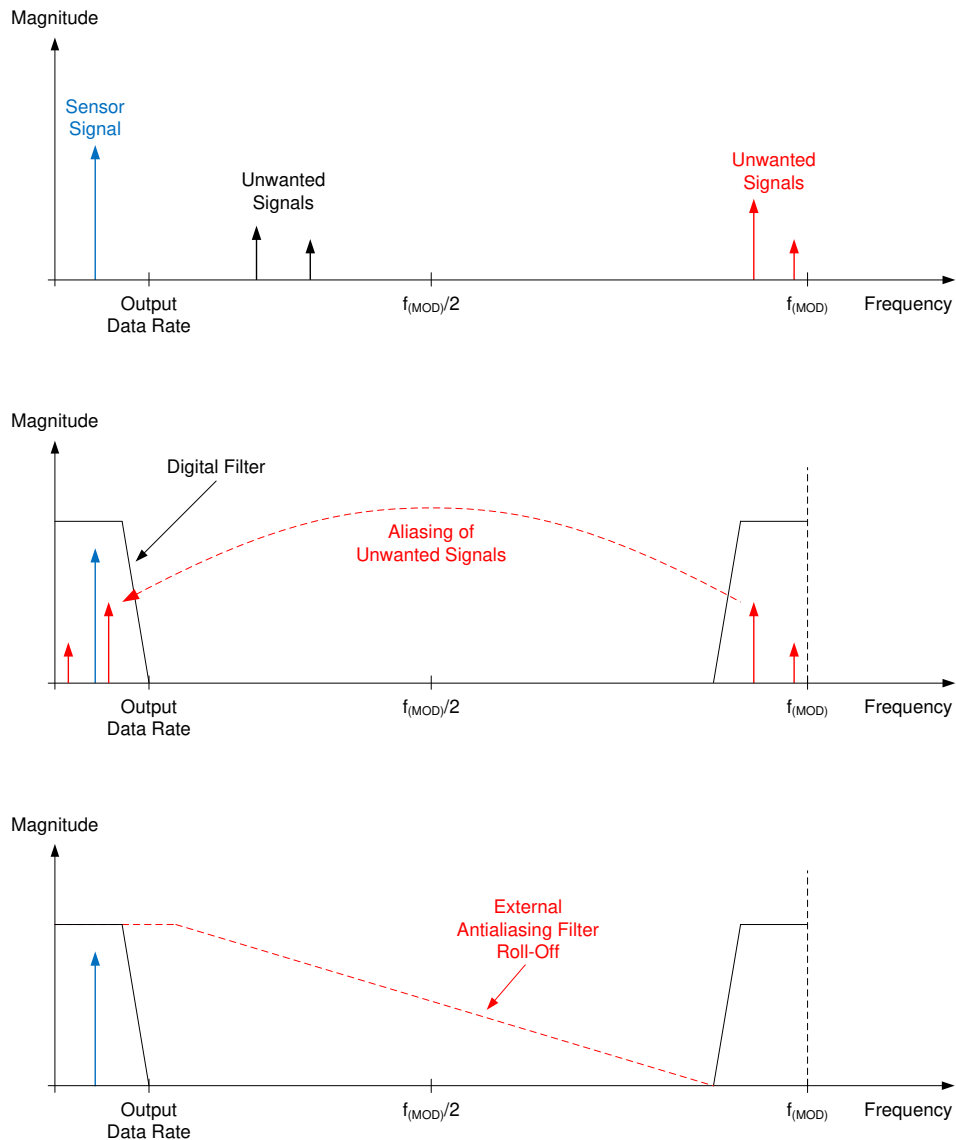
Most microcontroller SPI peripherals can operate with the ADS1220. The interface operates in SPI mode 1 where  $\text{CPOL} = 0$  and  $\text{CPHA} = 1$ . In SPI mode 1, SCLK idles low and data are launched or changed only on SCLK rising edges; data are latched or read by the controller and peripheral on SCLK falling edges. Details of the SPI communication protocol employed by the device can be found in the [SPI Timing Requirements](#) section.

Place  $47\Omega$  resistors in series with all digital input and output pins ( $\overline{\text{CS}}$ , SCLK, DIN, DOUT/DRDY, and DRDY). This resistance smooths sharp transitions, suppresses overshoot, and offers some overvoltage protection. Care must be taken to meet all SPI timing requirements because the additional resistors interact with the bus capacitances present on the digital signal lines.

### 9.1.2 Analog Input Filtering

Analog input filtering serves two purposes: first, to limit the effect of aliasing during the sampling process and second, to reduce external noise from being a part of the measurement.

As with any sampled system, aliasing can occur if proper antialias filtering is not in place. Aliasing occurs when frequency components are present in the input signal that are higher than half the sampling frequency of the ADC (also known as the *Nyquist frequency*). These frequency components are folded back and show up in the actual frequency band of interest below half the sampling frequency. Inside a  $\Delta\Sigma$  ADC, the input signal is sampled at the modulator frequency  $f_{\text{MOD}}$  and not at the output data rate. The filter response of the digital filter repeats at multiples of the sampling frequency ( $f_{\text{MOD}}$ ), as shown in Figure 9-2. Signals or noise up to a frequency where the filter response repeats are attenuated to a certain amount by the digital filter depending on the filter architecture. Any frequency components present in the input signal around the modulator frequency or multiples thereof are not attenuated and alias back into the band of interest, unless attenuated by an external analog filter.



**Figure 9-2. Effect of Aliasing**

Many sensor signals are inherently bandlimited; for example, the output of a thermocouple has a limited rate of change. In this case the sensor signal does not alias back into the pass-band when using a  $\Delta\Sigma$  ADC. However, any noise pick-up along the sensor wiring or the application circuitry can potentially alias into the pass-band. Power line-cycle frequency and harmonics are one common noise source. External noise can also be generated from electromagnetic interference (EMI) or radio frequency interference (RFI) sources, such as nearby motors and cellular phones. Another noise source typically exists on the printed circuit board (PCB) in the form of clocks and other digital signals. Analog input filtering helps remove unwanted signals from affecting the measurement result.

A first-order resistor-capacitor (RC) filter is (in most cases) sufficient to either totally eliminate aliasing, or to reduce the effect of aliasing to a level within the noise floor of the sensor. Ideally, any signal beyond  $f_{\text{MOD}} / 2$  is attenuated to a level below the noise floor of the ADC. The digital filter of the ADS1220 attenuates signals to a certain degree, as illustrated in the filter response plots in the [Digital Filter](#) section. In addition, noise components are typically smaller in magnitude than the actual sensor signal. Therefore, using a first-order RC filter with a cutoff frequency set at the output data rate or 10 times higher is generally a good starting point for a system design.

Internal to the device, prior to the PGA inputs, is an EMI filter; see [Figure 8-2](#). The cutoff frequency of this filter is approximately 31.8MHz, which helps reject high-frequency interferences.

### 9.1.3 External Reference and Ratiometric Measurements

The full-scale range of the ADS1220 is defined by the reference voltage and the PGA gain ( $\text{FSR} = \pm V_{\text{REF}} / \text{Gain}$ ). An external reference can be used instead of the integrated 2.048V reference to adapt the FSR to the specific system needs. An external reference must be used if  $V_{\text{IN}} > 2.048\text{V}$ . For example, an external 5V reference and an AVDD = 5V are required to measure a single-ended signal that can swing between 0V and 5V.

The reference inputs of the device also allow the implementation of ratiometric measurements. In a ratiometric measurement the same excitation source that is used to excite the sensor is also used to establish the reference for the ADC. As an example, a simple form of a ratiometric measurement uses the same current source to excite both the resistive sensor element (such as an RTD) and another resistive reference element that is in series with the element being measured. The voltage that develops across the reference element is used as the reference source for the ADC. Because current noise and drift are common to both the sensor measurement and the reference, these components cancel in the ADC transfer function. The output code is only a ratio of the sensor element and the value of the reference resistor. The value of the excitation current source is not part of the ADC transfer function.

### 9.1.4 Establishing a Proper Common-Mode Input Voltage

The ADS1220 can be used to measure various types of input signal configurations: single-ended, pseudo-differential, and fully-differential signals (which can be either unipolar or bipolar). However, configuring the device properly for the respective signal type is important.

Signals where the negative analog input is fixed and referenced to analog ground ( $V_{\text{AINN}} = 0\text{V}$ ) are commonly called *single-ended signals*. The common-mode voltage of a single-ended signal consequently varies between 0V and  $V_{\text{IN}} / 2$ . If the PGA is disabled and bypassed, the common-mode input voltage of the ADS1220 can be as low as 100mV below AVSS and as large as 100mV above AVDD. Therefore, the PGA\_BYPASS bit must be set to measure single-ended signals when a unipolar analog supply is used ( $\text{AVSS} = 0\text{V}$ ). Gains of 1, 2, and 4 are still possible in this configuration. Measuring a 0mA to 20mA or 4mA to 20mA signal across a load resistor of 100 $\Omega$  referenced to GND is a typical example. The ADS1220 can directly measure the signal across the load resistor using a unipolar supply, the internal 2.048V reference, and gain = 1 when the PGA is bypassed.

If gains larger than 4 are needed to measure a single-ended signal, the PGA must be enabled. In this case, a bipolar supply is required for the ADS1220 to meet the common-mode voltage requirement of the PGA.

Signals where the negative analog input ( $\text{AIN}_\text{N}$ ) is fixed at a voltage other than 0V are referred to as *pseudo-differential signals*. The common-mode voltage of a pseudo-differential signal varies between  $V_{\text{AINN}}$  and  $V_{\text{AINN}} + V_{\text{IN}} / 2$ .

*Fully-differential signals* in contrast are defined as signals having a constant common-mode voltage where the positive and negative analog inputs swing 180° out-of-phase but have the same amplitude.

The ADS1220 can measure pseudo-differential and fully-differential signals both with the PGA enabled or bypassed. However, the PGA must be enabled to use gains greater than 4. The common-mode voltage of the input signal must meet the input-common mode voltage restrictions of the PGA (as explained in the [PGA Common-Mode Voltage Requirements](#) section) when the PGA is enabled. Setting the common-mode voltage at or near  $(AVSS + AVDD) / 2$  in most cases satisfies the PGA common-mode voltage requirements.

Signals where both the positive and negative inputs are always  $\geq 0V$  are called *unipolar signals*. These signals can in general be measured with the ADS1220 using a unipolar analog supply ( $AVSS = 0V$ ). As mentioned previously, the PGA must be bypassed to measure single-ended, unipolar signals when using a unipolar supply.

A signal is called *bipolar* when either the positive or negative input can swing below 0V. A bipolar analog supply (such as  $AVDD = 2.5V$ ,  $AVSS = -2.5V$ ) is required to measure bipolar signals with the ADS1220. A typical application task is measuring a single-ended, bipolar  $\pm 10V$  signal where  $AIN_N$  is fixed at 0V while  $AIN_P$  swings between  $-10V$  and  $10V$ . The ADS1220 cannot directly measure this signal because the 10V exceeds the analog power-supply limits. However, one possible solution is to use a bipolar analog supply ( $AVDD = 2.5V$ ,  $AVSS = -2.5V$ ), gain = 1, and a resistor divider in front of the ADS1220. The resistor divider must divide the voltage down to  $\leq \pm 2.048V$  to be able to measure with the internal 2.048V reference.

### 9.1.5 Unused Inputs and Outputs

To minimize leakage currents on the analog inputs, leave unused analog and reference inputs floating, or connect the inputs to mid-supply or to AVDD.  $AIN3/REFN1$  is an exception. Leave the  $AIN3/REFN1$  pin floating when not used to avoid accidentally shorting the pin to AVSS through the internal low-side switch. Connecting unused analog or reference inputs to AVSS is possible as well, but can yield higher leakage currents than the previously mentioned options.

Do not float unused digital inputs; excessive power-supply leakage current can result. Tie all unused digital inputs to the appropriate levels, DVDD or DGND, even when in power-down mode. If  $\overline{CS}$  is not used, tie this pin to DGND. If the internal oscillator is used, tie the CLK pin to DGND. If the  $\overline{DRDY}$  output is not used, leave the pin unconnected or tie the pin to DVDD using a weak pullup resistor.

### 9.1.6 Pseudo Code Example

The following list shows a pseudo code sequence with the required steps to set up the device and the microcontroller that interfaces to the ADC to take subsequent readings from the ADS1220 in continuous conversion mode. The dedicated  $\overline{\text{DRDY}}$  pin is used to indicate availability of new conversion data. The default configuration register settings are changed to gain = 16, continuous conversion mode, and simultaneous 50Hz and 60Hz rejection.

```

Power-up;
Delay to allow power supplies to settle and power-up reset to complete (minimum of 50µs);
Configure the SPI interface of the microcontroller to SPI mode 1 (CPOL = 0, CPHA = 1);
If the  $\overline{\text{CS}}$  pin is not tied low permanently, configure the microcontroller GPIO connected to  $\overline{\text{CS}}$  as an
output;
Configure the microcontroller GPIO connected to the  $\overline{\text{DRDY}}$  pin as a falling edge triggered interrupt
input;
Set  $\overline{\text{CS}}$  to the device low;
Delay for a minimum of  $t_{d(\text{CSSC})}$ ;
Send the RESET command (06h) to make sure the device is properly reset after power-up;
Delay for a minimum of  $50\mu\text{s} + 32 \times t_{\text{CLK}}$ ;
Write the respective register configuration with the WREG command (43h, 08h, 04h, 10h, and 00h);
As an optional sanity check, read back all configuration registers with the RREG command (23h);
Send the START/SYNC command (08h) to start converting in continuous conversion mode;
Delay for a minimum of  $t_{d(\text{SCCS})}$ ;
Clear  $\overline{\text{CS}}$  to high (resets the serial interface);
Loop
{
    wait for  $\overline{\text{DRDY}}$  to transition low;
    Take  $\overline{\text{CS}}$  low;
    Delay for a minimum of  $t_{d(\text{CSSC})}$ ;
    Send 24 SCLK rising edges to read out conversion data on DOUT/ $\overline{\text{DRDY}}$ ;
    Delay for a minimum of  $t_{d(\text{SCCS})}$ ;
    Clear  $\overline{\text{CS}}$  to high;
}
Take  $\overline{\text{CS}}$  low;
Delay for a minimum of  $t_{d(\text{CSSC})}$ ;
Send the POWERDOWN command (02h) to stop conversions and put the device in power-down mode;
Delay for a minimum of  $t_{d(\text{SCCS})}$ ;
Clear  $\overline{\text{CS}}$  to high;

```

Run an offset calibration before performing any measurements or when changing the gain of the PGA. The internal offset of the device can, for example, be measured by shorting the inputs to mid-supply (MUX[3:0] = 1110b). The microcontroller then takes multiple readings from the device with the inputs shorted and stores the average value in the microcontroller memory. When measuring the sensor signal, the microcontroller then subtracts the stored offset value from each device reading to obtain an offset compensated result. The offset can be either positive or negative in value.

## 9.2 Typical Applications

### 9.2.1 K-Type Thermocouple Measurement (–200°C to +1250°C)

Figure 9-3 shows the basic connections of a thermocouple measurement system when using the internal high-precision temperature sensor for cold-junction compensation. Apart from the thermocouple, the only external circuitry required are two biasing resistors, a simple low-pass, antialiasing filter, and the power-supply decoupling capacitors.

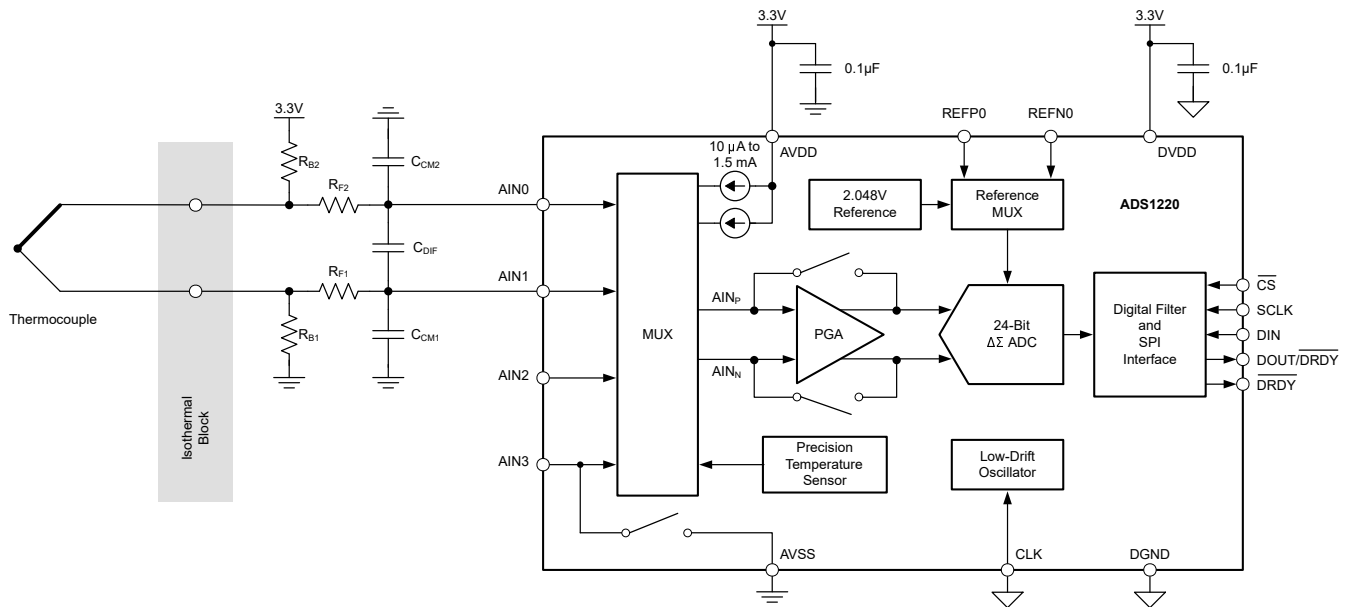


Figure 9-3. Thermocouple Measurement

#### 9.2.1.1 Design Requirements

Table 9-1. Design Requirements

DESIGN PARAMETER	VALUE
Supply voltage	3.3V
Reference voltage	Internal 2.048V reference
Update rate	≥10 readings per second
Thermocouple type	K
Temperature measurement range	–200°C to +1250°C
Measurement accuracy at $T_A = 25^\circ\text{C}^{(1)}$	±0.2°C

(1) Not accounting for error of the thermocouple and cold-junction temperature measurement; offset calibration at  $T_{(TC)} = T_{(CJ)} = 25^\circ\text{C}$ ; no gain calibration.

#### 9.2.1.2 Detailed Design Procedure

The biasing resistors  $R_{B1}$  and  $R_{B2}$  are used to set the common-mode voltage of the thermocouple to within the specified common-mode voltage range of the PGA (in this example, to mid-supply  $AVDD / 2$ ). If the application requires the thermocouple to be biased to GND, either a bipolar supply (for example,  $AVDD = 2.5\text{V}$  and  $AVSS = -2.5\text{V}$ ) must be used for the device to meet the common-mode voltage requirement of the PGA, or the PGA must be bypassed. When choosing the values of the biasing resistors, care must be taken so that the biasing current does not degrade measurement accuracy. The biasing current flows through the thermocouple and can cause self-heating and additional voltage drops across the thermocouple leads. Typical values for the biasing resistors range from 1MΩ to 50MΩ.

In addition to biasing the thermocouple,  $R_{B1}$  and  $R_{B2}$  are also useful for detecting an open thermocouple lead. When one of the thermocouple leads fails open, the biasing resistors pull the analog inputs (AIN0 and AIN1) to AVDD and AVSS, respectively. The ADC consequently reads a full-scale value, which is outside the normal measurement range of the thermocouple voltage, to indicate this failure condition.

Although the device digital filter attenuates high-frequency components of noise, performance can be further improved by providing a first-order, passive RC filter at the inputs. Equation 16 calculates the cutoff frequency that is created by the differential RC filter formed by  $R_{F1}$ ,  $R_{F2}$ , and the differential capacitor  $C_{DIF}$ .

$$f_c = 1 / [2\pi \times (R_{F1} + R_{F2}) \times C_{DIF}] \quad (16)$$

Two common-mode filter capacitors ( $C_{M1}$  and  $C_{M2}$ ) are also added to offer attenuation of high-frequency, common-mode noise components. Select a differential capacitor  $C_{DIF}$  that is at least an order of magnitude (10 times) larger than the common-mode capacitors ( $C_{M1}$  and  $C_{M2}$ ) because mismatches in the common-mode capacitors can convert common-mode noise into differential noise.

The filter resistors  $R_{F1}$  and  $R_{F2}$  also serve as current-limiting resistors. These resistors limit the current into the analog inputs (AIN0 and AIN1) of the device to safe levels if an overvoltage on the inputs occur. Care must be taken when choosing the filter resistor values because the input currents flowing into and out of the device cause a voltage drop across the resistors. This voltage drop shows up as an additional offset error at the ADC inputs. Limit the filter resistor values to below 1k $\Omega$ , if possible.

The filter component values used in this design are:  $R_{F1} = R_{F2} = 1\text{k}\Omega$ ,  $C_{DIF} = 100\text{nF}$ , and  $C_{M1} = C_{M2} = 10\text{nF}$ .

The highest measurement resolution is achieved when matching the largest potential input signal to the FSR of the ADC by choosing the highest possible gain. From the design requirement, the maximum thermocouple voltage occurs at  $T_{TC} = 1250^\circ\text{C}$  and is  $V_{TC} = 50.644\text{mV}$  as defined in the tables published by the [National Institute of Standards and Technology \(NIST\)](#) using a cold-junction temperature of  $T_{CJ} = 0^\circ\text{C}$ . A thermocouple produces an output voltage that is proportional to the temperature difference between the thermocouple tip and the cold junction. If the cold junction is at a temperature below  $0^\circ\text{C}$ , the thermocouple produces a voltage larger than 50.644mV. The isothermal block area is constrained by the operating temperature range of the device. Therefore, the isothermal block temperature is limited to  $-40^\circ\text{C}$ . A K-type thermocouple at  $T_{TC} = 1250^\circ\text{C}$  produces an output voltage of  $V_{TC} = 50.644\text{mV} - (-1.527\text{mV}) = 52.171\text{mV}$  when referenced to a cold-junction temperature of  $T_{CJ} = -40^\circ\text{C}$ . The maximum gain that can be applied when using the internal 2.048V reference is then calculated as  $(2.048\text{V} / 52.171\text{mV}) = 39.3$ . The next smaller PGA gain setting the device offers is 32.

The device integrates a high-precision temperature sensor that can be used to measure the temperature of the cold junction. To measure the internal temperature of the ADS1220, the device must be set to internal temperature sensor mode by setting the TS bit to 1b in the configuration register. For best performance, careful board layout is critical to achieve good thermal conductivity between the cold junction and the device package.

However, the device does not perform automatic cold-junction compensation of the thermocouple. This compensation must be done in the microcontroller that interfaces to the device. The microcontroller requests one or multiple readings of the thermocouple voltage from the device and then sets the device to internal temperature sensor mode (TS = 1b) to acquire the temperature of the cold junction. An algorithm similar to the following must be implemented on the microcontroller to compensate for the cold-junction temperature:

1. Measure the thermocouple voltage,  $V_{TC}$ , between AIN0 and AIN1.
2. Measure the temperature of the cold junction,  $T_{CJ}$ , using the temperature sensor mode of the ADS1220.
3. Convert the cold-junction temperature into an equivalent thermoelectric voltage,  $V_{CJ}$ , using the tables or equations provided by NIST.
4. Add  $V_{TC}$  and  $V_{CJ}$  and translate the summation back into a thermocouple temperature using the NIST tables or equations again.

In some applications, the integrated temperature sensor of the ADS1220 cannot be used (for example, if the accuracy is not high enough or if the device cannot be placed close enough to the cold junction). The additional analog input channels of the device can be used in this case to measure the cold-junction temperature with a thermistor, RTD, or an analog temperature sensor.

To get an approximation of the achievable temperature resolution, the rms-Noise of the ADS1220 at Gain = 32 and DR = 20SPS ( $0.23\mu V_{rms}$ ) is divided by the average sensitivity of a K-type thermocouple ( $41\mu V/^{\circ}C$ ), as shown in Equation 17.

$$\text{Temperature Resolution} = 0.23\mu V / 41\mu V/^{\circ}C = 0.006^{\circ}C \tag{17}$$

The register settings for this design are shown in Table 9-2.

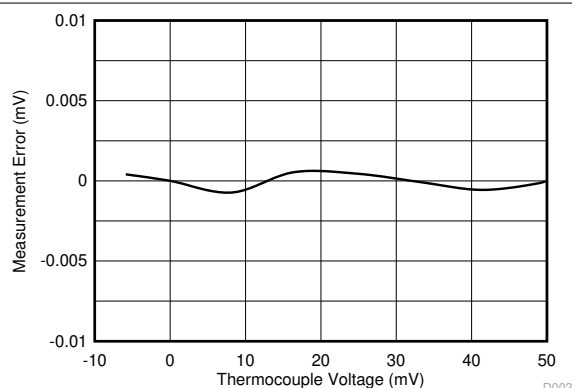
**Table 9-2. Register Settings**

REGISTER	SETTING	DESCRIPTION
00h	0Ah	AIN <sub>P</sub> = AIN <sub>0</sub> , AIN <sub>N</sub> = AIN <sub>1</sub> , gain = 32, PGA enabled
01h	04h	DR = 20SPS, normal mode, continuous conversion mode
02h	10h	Internal voltage reference, simultaneous 50Hz and 60Hz rejection
03h	00h	No IDACs used

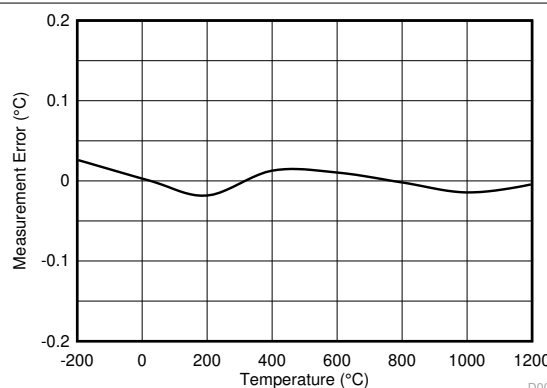
**9.2.1.3 Application Curves**

Figure 9-4 and Figure 9-5 show the measurement results. The measurements are taken at  $T_A = T_{(CJ)} = 25^{\circ}C$ . A system offset calibration is performed at  $T_{(TC)} = 25^{\circ}C$ , which translates to a  $V_{(TC)} = 0V$  when  $T_{(CJ)} = 25^{\circ}C$ . No gain calibration is implemented. The data in Figure 9-4 are taken using a precision voltage source as the input signal instead of a thermocouple. The respective temperature measurement error in Figure 9-5 is calculated from the data in Figure 9-4 using the NIST tables.

The design meets the required temperature measurement accuracy given in Table 9-1. The measurement error shown in Figure 9-5 does not include the error of the thermocouple and the measurement error of the cold-junction temperature. Those two error sources are in general larger than  $0.2^{\circ}C$  and therefore, in many cases, dominate the overall system measurement accuracy.



**Figure 9-4. Voltage Measurement Error vs  $V_{TC}$**



**Figure 9-5. Temperature Measurement Error vs  $T_{TC}$**

### 9.2.2 3-Wire RTD Measurement (–200°C to +850°C)

The ADS1220 integrates all necessary features (such as dual-matched programmable current sources, buffered reference inputs, and a PGA) to ease the implementation of ratiometric 2-, 3-, and 4-wire RTD measurements. Figure 9-6 shows a typical implementation of a ratiometric 3-wire RTD measurement using the excitation current sources integrated in the device to excite the RTD as well as to implement automatic RTD lead-resistance compensation.

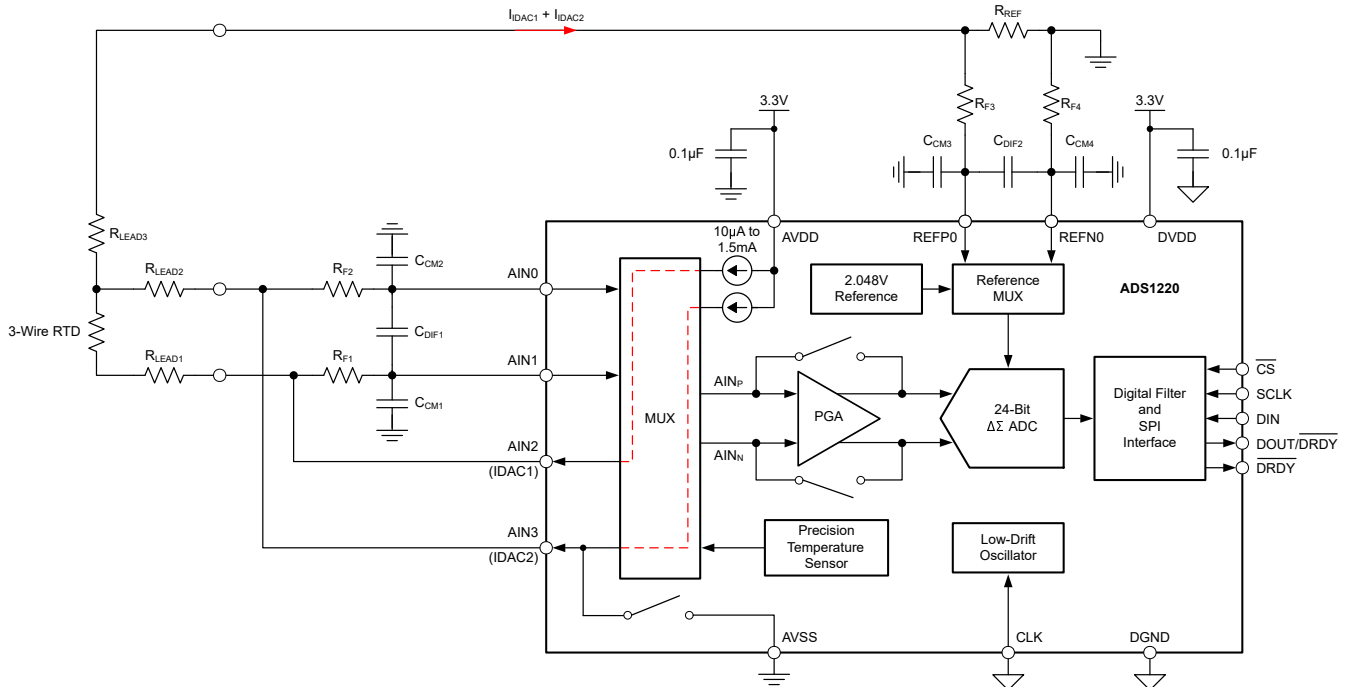


Figure 9-6. 3-Wire RTD Measurement

#### 9.2.2.1 Design Requirements

Table 9-3. Design Requirements

DESIGN PARAMETER	VALUE
Supply voltage	3.3V
Update rate	20 readings per second
RTD type	3-wire Pt100
Maximum RTD lead resistance	15Ω
RTD excitation current	500μA
Temperature measurement range	–200°C to +850°C
Measurement accuracy at $T_A = 25^\circ\text{C}^{(1)}$	$\pm 0.2^\circ\text{C}$

(1) Not accounting for error of RTD; offset calibration is performed with  $R_{RTD} = 100\Omega$ ; no gain calibration.

#### 9.2.2.2 Detailed Design Procedure

The circuit in Figure 9-6 employs a ratiometric measurement approach. In other words, the sensor signal (that is, the voltage across the RTD in this case) and the reference voltage for the ADC are derived from the same excitation source. Therefore, errors resulting from temperature drift or noise of the excitation source cancel because these errors are common to both the sensor signal and the reference.

To implement a ratiometric 3-wire RTD measurement using the device, IDAC1 is routed to one of the leads of the RTD and IDAC2 is routed to the second RTD lead. Both currents have the same value, which is programmable by the IDAC[2:0] bits in the configuration register. The device is designed such that both IDAC values are closely matched, even across temperature. The sum of both currents flows through a precision, low-drift reference resistor,  $R_{REF}$ . The voltage,  $V_{REF}$ , generated across the reference resistor (as shown in Equation 18) is used as the ADC reference voltage. Equation 18 reduces to Equation 19 because  $I_{IDAC1} = I_{IDAC2}$ .

$$V_{REF} = (I_{IDAC1} + I_{IDAC2}) \times R_{REF} \quad (18)$$

$$V_{REF} = 2 \times I_{IDAC1} \times R_{REF} \quad (19)$$

To simplify the following discussion, the individual lead resistance values of the RTD ( $R_{LEADx}$ ) are set to zero. Only IDAC1 excites the RTD to produce a voltage ( $V_{RTD}$ ) proportional to the temperature-dependable RTD value and the IDAC1 value, as shown in Equation 20.

$$V_{RTD} = R_{RTD} \text{ (at temperature)} \times I_{IDAC1} \quad (20)$$

The device internally amplifies the voltage across the RTD using the PGA and compares the resulting voltage against the reference voltage to produce a digital output code proportional to Equation 21 through Equation 23:

$$\text{Code} \propto V_{RTD} \times \text{Gain} / V_{REF} \quad (21)$$

$$\text{Code} \propto (R_{RTD} \text{ (at temperature)} \times I_{IDAC1} \times \text{Gain}) / (2 \times I_{IDAC1} \times R_{REF}) \quad (22)$$

$$\text{Code} \propto (R_{RTD} \text{ (at temperature)} \times \text{Gain}) / (2 \times R_{REF}) \quad (23)$$

As can be seen from Equation 23, the output code only depends on the value of the RTD, the PGA gain, and the reference resistor ( $R_{REF}$ ), but not on the IDAC1 value. The absolute accuracy and temperature drift of the excitation current therefore does not matter. However, because the value of the reference resistor directly affects the measurement result, choosing a reference resistor with a very low temperature coefficient is important to limit errors introduced by the temperature drift of  $R_{REF}$ .

The second IDAC2 is used to compensate for errors introduced by the voltage drop across the lead resistance of the RTD. All three leads of a 3-wire RTD typically have the same length and, thus, the same lead resistance. Also, IDAC1 and IDAC2 have the same value. Taking the lead resistance into account, the differential voltage ( $V_{IN}$ ) across the ADC inputs, AIN0 and AIN1, is calculated using Equation 24:

$$V_{IN} = I_{IDAC1} \times (R_{RTD} + R_{LEAD1}) - I_{IDAC2} \times R_{LEAD2} \quad (24)$$

When  $R_{LEAD1} = R_{LEAD2}$  and  $I_{IDAC1} = I_{IDAC2}$ , Equation 24 reduces to Equation 25:

$$V_{IN} = I_{IDAC1} \times R_{RTD} \quad (25)$$

In other words, the measurement error resulting from the voltage drop across the RTD lead resistance is compensated, as long as the lead resistance values and the IDAC values are well matched.

A first-order differential and common-mode RC filter ( $R_{F1}$ ,  $R_{F2}$ ,  $C_{DIF1}$ ,  $C_{CM1}$ , and  $C_{CM2}$ ) is placed on the ADC inputs, as well as on the reference inputs ( $R_{F3}$ ,  $R_{F4}$ ,  $C_{DIF2}$ ,  $C_{CM3}$ , and  $C_{CM4}$ ). The same guidelines for designing the input filter apply as described in the [Thermocouple Measurement](#) section. Match the corner frequencies of the input and reference filter for best performance. More detailed information on matching the input and reference filter can be found in the [RTD Ratiometric Measurements and Filtering Using the ADS1148 and ADS1248](#) application note.

The reference resistor  $R_{REF}$  not only serves to generate the reference voltage for the device, but also sets the common-mode voltage of the RTD to within the specified common-mode voltage range of the PGA.

When designing the circuit, care must also be taken to meet the compliance voltage requirement of the IDACs. The IDACs require that the maximum voltage drop developed across the current path to AVSS be equal or less than  $AVDD - 0.9V$  to operate accurately. This requirement means that [Equation 26](#) must be met at all times.

$$AVSS + I_{IDAC1} \times (R_{LEAD1} + R_{RTD}) + (I_{IDAC1} + I_{IDAC2}) \times (R_{LEAD3} + R_{REF}) \leq AVDD - 0.9V \quad (26)$$

The device also offers the possibility to route the IDACs to the same inputs used for measurement. If the filter resistor values  $R_{F1}$  and  $R_{F2}$  are small enough and well matched, IDAC1 can be routed to AIN1 and IDAC2 to AIN0 in [Figure 9-6](#). In this manner, even two 3-wire RTDs sharing the same reference resistor can be measured with a single device.

This design example discusses the implementation of a 3-wire Pt100 measurement to be used to measure temperatures ranging from  $-200^{\circ}C$  to  $+850^{\circ}C$  as stated in [Table 9-3](#). The excitation current for the Pt100 is chosen as  $I_{IDAC1} = 500\mu A$ , which means a combined current of 1mA is flowing through the reference resistor,  $R_{REF}$ . As mentioned previously, besides creating the reference voltage for the ADS1220, the voltage across  $R_{REF}$  also sets the common-mode voltage for the RTD measurement. In general, select the largest reference voltage possible while still maintaining the compliance voltage of the IDACs as well as meeting the common-mode voltage requirement of the PGA. Set the common-mode voltage at or near half the analog supply (in this case  $3.3V / 2 = 1.65V$ ), which in most cases satisfies the common-mode voltage requirements of the PGA. The value for  $R_{REF}$  is then calculated by [Equation 27](#):

$$R_{REF} = V_{REF} / (I_{IDAC1} + I_{IDAC2}) = 1.65V / 1mA = 1.65k\Omega \quad (27)$$

The stability of  $R_{REF}$  is critical to achieve good measurement accuracy over temperature and time. Choosing a reference resistor with a temperature coefficient of  $\pm 10ppm/^{\circ}C$  or better is advisable. If a 1.65k $\Omega$  value is not readily available, another value near 1.65k $\Omega$  (such as 1.62k $\Omega$  or 1.69k $\Omega$ ) can certainly be used as well.

As a last step, the PGA gain must be selected to match the maximum input signal to the FSR of the ADC. The resistance of a Pt100 increases with temperature. Therefore, the maximum voltage to be measured ( $V_{INMAX}$ ) occurs at the positive temperature extreme. At  $850^{\circ}C$ , a Pt100 has an equivalent resistance of approximately 391 $\Omega$  as per the NIST tables. The voltage across the Pt100 equates to [Equation 28](#):

$$V_{INMAX} = V_{RTD} \text{ (at } 850^{\circ}C) = R_{RTD} \text{ (at } 850^{\circ}C) \times I_{IDAC1} = 391\Omega \times 500\mu A = 195.5mV \quad (28)$$

The maximum gain that can be applied when using a 1.65V reference is then calculated as  $(1.65V / 195.5mV) = 8.4$ . The next smaller PGA gain setting available in the ADS1220 is 8. At a gain of 8, the ADS1220 offers a FSR value as described in [Equation 29](#):

$$FSR = \pm V_{REF} / \text{Gain} = \pm 1.65V / 8 = \pm 206.25mV \quad (29)$$

This range allows for margin with respect to initial accuracy and drift of the IDACs and reference resistor.

After selecting the values for the IDACs,  $R_{REF}$ , and PGA gain, make sure to double check that the settings meet the common-mode voltage requirements of the PGA and the compliance voltage of the IDACs. To determine the true common-mode voltage at the ADC inputs (AIN0 and AIN1) the lead resistance must be taken into account as well.

The smallest common-mode voltage occurs at the lowest measurement temperature ( $-200^{\circ}C$ ) with  $R_{LEADx} = 0\Omega$  and is calculated using [Equation 30](#) and [Equation 31](#).

$$V_{CMMIN} = V_{REF} + (I_{IDAC1} + I_{IDAC2}) \times R_{LEAD3} + I_{IDAC2} \times R_{LEAD2} + \frac{1}{2} I_{IDAC1} \times R_{RTD} \text{ (at } -200^{\circ}C) \quad (30)$$

$$V_{CMMIN} = 1.65V + \frac{1}{2} 500\mu A \times 18.52\Omega = 1.655V \quad (31)$$

Actually, assuming  $V_{CMMIN} = V_{REF}$  is a sufficient approximation.

$V_{\text{CMMIN}}$  must meet two requirements: Equation 14 requires  $V_{\text{CMMIN}}$  to be larger than  $AV_{\text{DD}} / 4 = 3.3\text{V} / 4 = 0.825\text{V}$  and Equation 12 requires  $V_{\text{CMMIN}}$  to meet Equation 32:

$$V_{\text{CMMIN}} \geq AV_{\text{SS}} + 0.2\text{V} + \frac{1}{2} \text{Gain} \times V_{\text{INMAX}} = 0\text{V} + 0.2\text{V} + (\frac{1}{2} \times 8 \times 195.5\text{mV}) = 982\text{mV} \quad (32)$$

Both restrictions are satisfied in this design with a  $V_{\text{CMMIN}} = 1.65\text{V}$ .

The largest common-mode voltage occurs at the highest measurement temperature (850°C) and is calculated using Equation 33 and Equation 34.

$$V_{\text{CMMAX}} = V_{\text{REF}} + (I_{\text{IDAC1}} + I_{\text{IDAC2}}) \times R_{\text{LEAD3}} + I_{\text{IDAC2}} \times R_{\text{LEAD2}} + \frac{1}{2} I_{\text{IDAC1}} \times R_{\text{RTD (at 850°C)}} \quad (33)$$

$$V_{\text{CMMAX}} = 1.65\text{V} + 1\text{mA} \times 15\Omega + 500\mu\text{A} \times 15\Omega + \frac{1}{2} \times 500\mu\text{A} \times 391\Omega = 1.77\text{V} \quad (34)$$

$V_{\text{CMMAX}}$  does meet the requirement given by Equation 13, which in this design equates to Equation 35:

$$V_{\text{CMMAX}} \leq AV_{\text{DD}} - 0.2\text{V} - \frac{1}{2} \text{Gain} \times V_{\text{INMAX}} = 3.3\text{V} - 0.2\text{V} - (\frac{1}{2} \times 8 \times 195.5\text{mV}) = 2.318\text{V} \quad (35)$$

Finally, the maximum voltage that can occur on input AIN1 must be calculated to determine if the compliance voltage ( $AV_{\text{DD}} - 0.9\text{V} = 3.3\text{V} - 0.9\text{V} = 2.4\text{V}$ ) of IDAC1 is met. The voltage on input AIN0 is smaller than the one on input AIN1. Equation 36 and Equation 37 show that the voltage on AIN1 is less than 2.4V, even when taking the worst-case lead resistance into account.

$$V_{\text{AIN1 (MAX)}} = V_{\text{REF}} + (I_{\text{IDAC1}} + I_{\text{IDAC2}}) \times R_{\text{LEAD3}} + I_{\text{IDAC1}} \times (R_{\text{RTD (at 850°C)}} + R_{\text{LEAD1}}) \quad (36)$$

$$V_{\text{AIN1 (MAX)}} = 1.65\text{V} + 1\text{mA} \times 15\Omega + 500\mu\text{A} \times (391\Omega + 15\Omega) = 1.868\text{V} \quad (37)$$

The register settings for this design are shown in Table 9-4.

**Table 9-4. Register Settings**

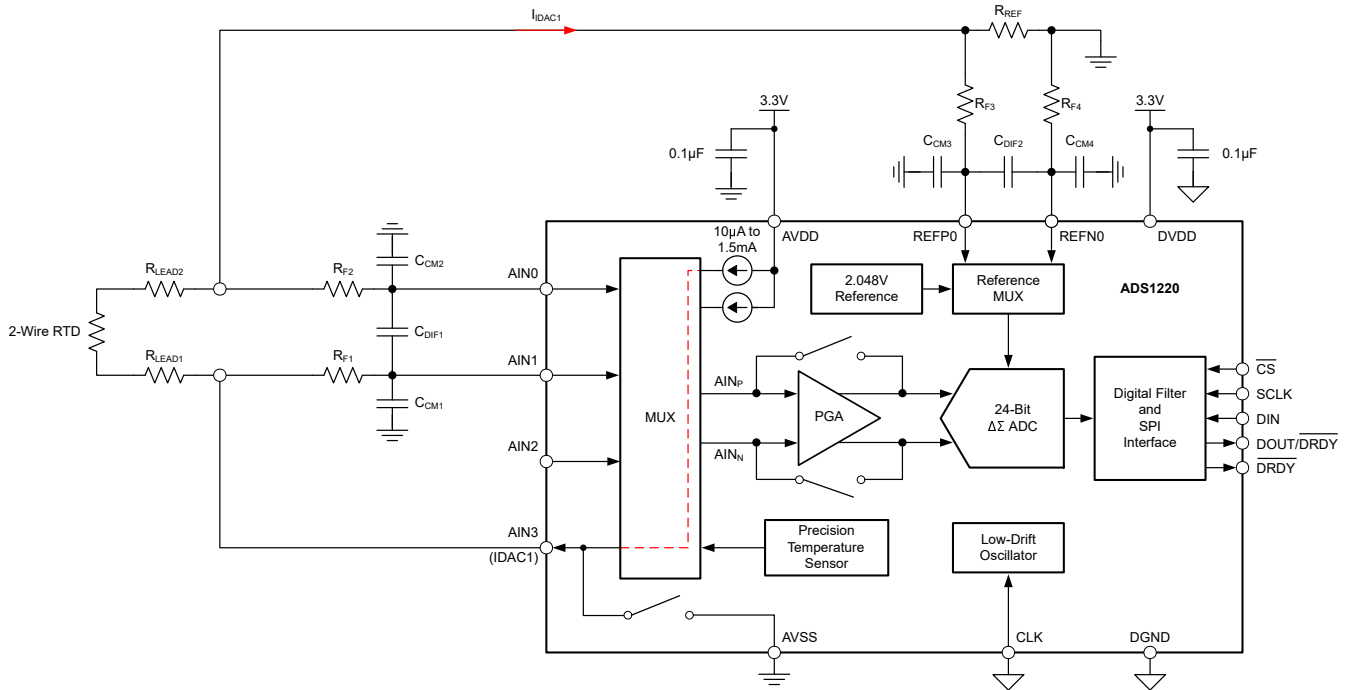
REGISTER	SETTING	DESCRIPTION
00h	66h	$\text{AIN}_P = \text{AIN1}$ , $\text{AIN}_N = \text{AIN0}$ , gain = 8, PGA enabled
01h	04h	DR = 20SPS, normal mode, continuous conversion mode
02h	55h	External reference (REFP0, REFN0), simultaneous 50Hz and 60Hz rejection, IDAC = 500μA
03h	70h	IDAC1 = AIN2, IDAC2 = AIN3

**9.2.2.2.1 Design Variations for 2-Wire and 4-Wire RTD Measurements**

Implementing a 2- or 4-wire RTD measurement is very similar to the 3-wire RTD measurement illustrated in Figure 9-6, except that only one IDAC is required.

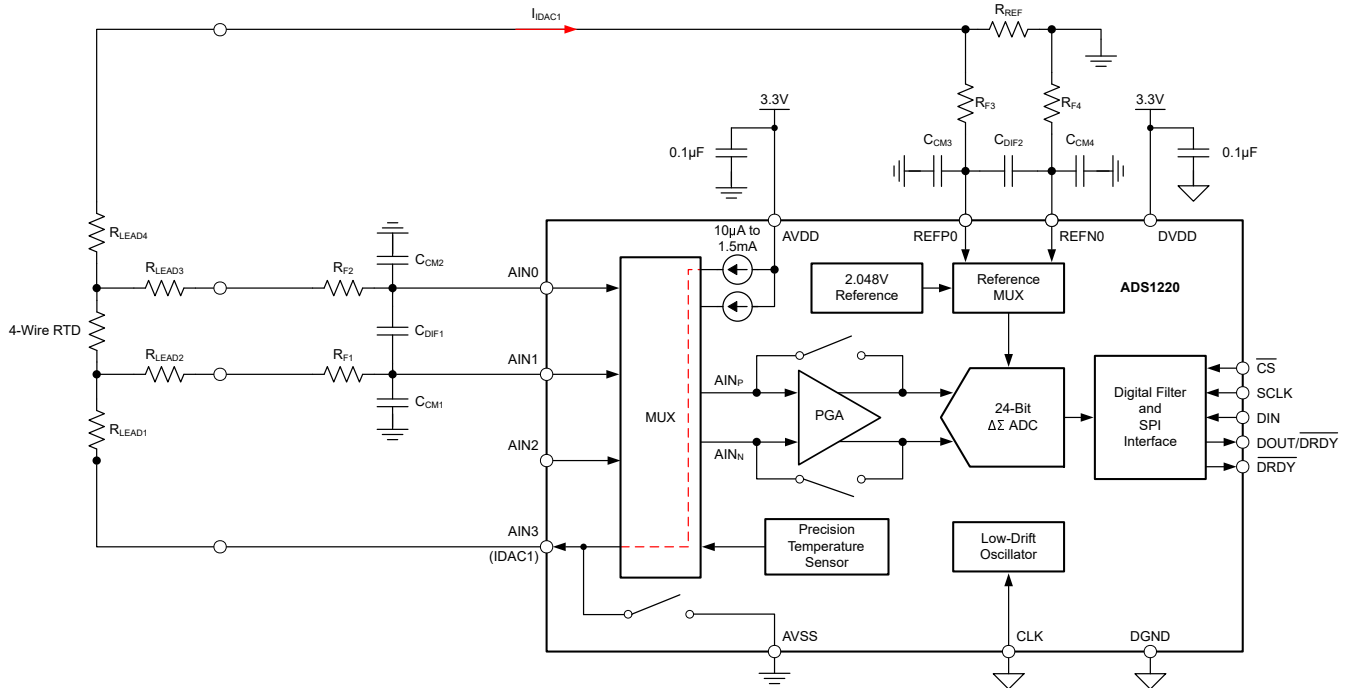
Figure 9-7 shows a typical circuit implementation of a 2-wire RTD measurement. The main difference compared to a 3-wire RTD measurement is with respect to the lead resistance compensation. The voltage drop across the lead resistors,  $R_{LEAD1}$  and  $R_{LEAD2}$ , in this configuration is directly part of the measurement (as shown in Equation 38) because there is no means to compensate the lead resistance by use of the second current source. Any compensation must be done by calibration.

$$V_{IN} = I_{IDAC1} \times (R_{LEAD1} + R_{RTD} + R_{LEAD2}) \tag{38}$$



**Figure 9-7. 2-Wire RTD Measurement**

Figure 9-8 shows a typical circuit implementation of a 4-wire RTD measurement. Similar to the 2-wire RTD measurement, only one IDAC is required for exciting and measuring a 4-wire RTD in a ratiometric manner. The main benefit of using a 4-wire RTD is that the ADC inputs are connected to the RTD in the form of a Kelvin connection. Apart from the input leakage currents of the ADC, there is no current flow through the lead resistors  $R_{LEAD2}$  and  $R_{LEAD3}$  and therefore no voltage drop is created across them. The voltage at the ADC inputs consequently equals the voltage across the RTD and the lead resistance is of no concern.



**Figure 9-8. 4-Wire RTD Measurement**

As shown in Equation 39, the transfer function of a 2- and 4-wire RTD measurement differs compared to the one of a 3-wire RTD measurement by a factor of 2 because only one IDAC is used and only one IDAC flows through the reference resistor,  $R_{REF}$ .

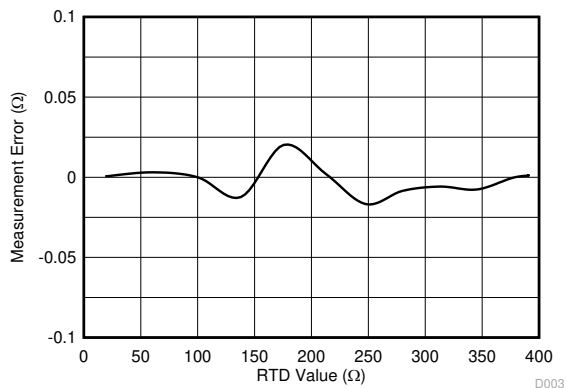
$$\text{Code} \propto (R_{RTD} \text{ (at Temperature)} \times \text{Gain}) / R_{REF} \tag{39}$$

In addition, the common-mode and reference voltage is reduced compared to the 3-wire RTD configuration. Therefore, some further modifications can be required in case the 3-wire RTD design is used to measure 2- and 4-wire RTDs as well. If the decreased common-mode voltage does not meet the  $V_{CMMIN}$  requirements of the PGA anymore, either increase the value of  $R_{REF}$  by switching in a larger resistor or, alternatively, increase the excitation current while decreasing the gain at the same time.

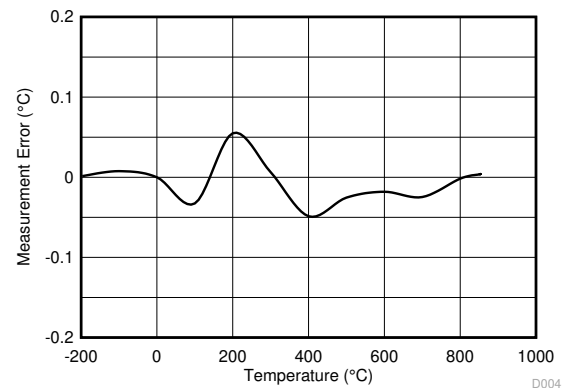
### 9.2.2.3 Application Curves

Figure 9-9 and Figure 9-10 show the measurement results. The measurements are taken at  $T_A = 25^\circ\text{C}$ . A system offset calibration is performed using a reference resistor of  $100\Omega$ . No gain calibration is implemented. The data in Figure 9-9 are taken using precision resistors instead of a 3-wire Pt100. The respective temperature measurement error in Figure 9-10 is calculated from the data in Figure 9-9 using the NIST tables.

The design meets the required temperature measurement accuracy given in Table 9-3. The measurement error shown in Figure 9-10 does not include the error of the RTD.



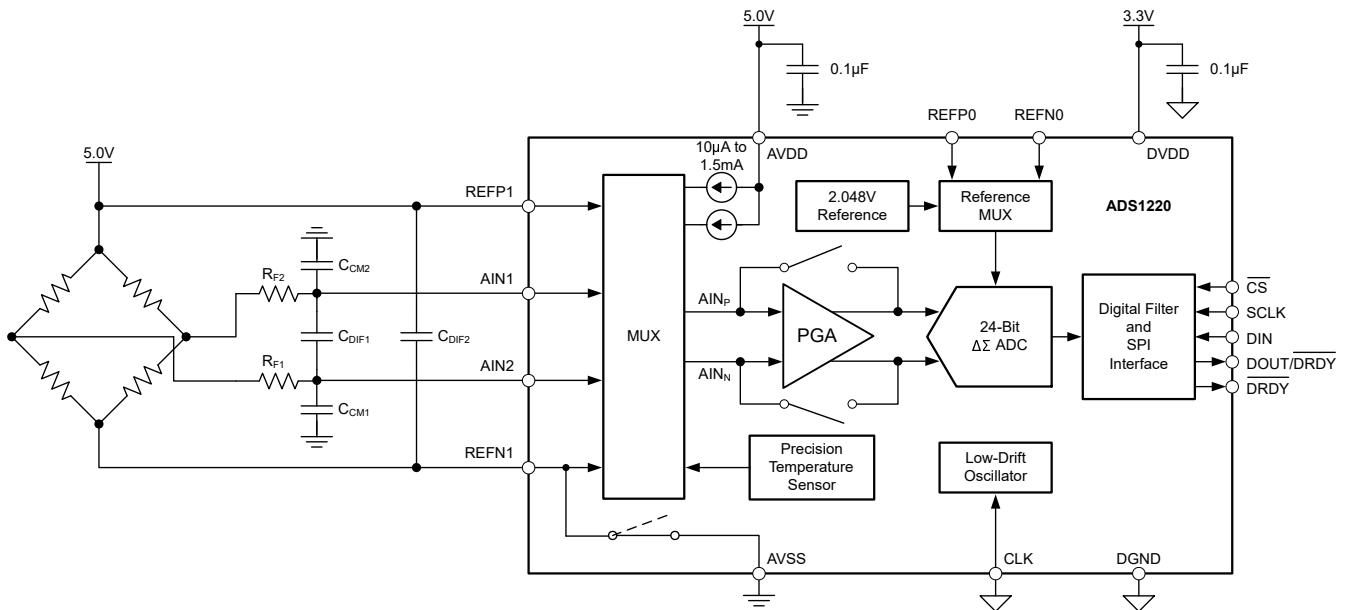
**Figure 9-9. Resistance Measurement Error vs  $R_{RTD}$**



**Figure 9-10. Temperature Measurement Error vs  $T_{RTD}$**

### 9.2.3 Resistive Bridge Measurement

The device offers several features to ease the implementation of ratiometric bridge measurements (such as a PGA with gains up to 128, buffered, differential reference inputs, and a low-side power switch).



**Figure 9-11. Resistive Bridge Measurement**

#### 9.2.3.1 Design Requirements

**Table 9-5. Design Requirements**

DESIGN PARAMETER	VALUE
Analog supply voltage	5.0V
Digital supply voltage	3.3V
Load cell type	4-wire load cell
Load cell maximum capacity	1kg
Load cell sensitivity	3mV/V
Excitation voltage	5V
Repeatability	50mg

#### 9.2.3.2 Detailed Design Procedure

To implement a ratiometric bridge measurement, the bridge excitation voltage is simultaneously used as the reference voltage for the ADC, as shown in Figure 9-11. With this configuration, any drift in excitation voltage also shows up on the reference voltage, consequently canceling out drift error. Either of the two device reference input pairs can be connected to the bridge excitation voltage. However, only the negative reference input (REFN1) can be internally routed to a low-side power switch. By connecting the low side of the bridge to REFN1, the device can automatically power-down the bridge by opening the low-side power switch. When the PSW bit in the configuration register is set to 1b, the device opens the switch every time a POWERDOWN command is issued and closes the switch again when a START/SYNC command is sent.

The PGA offers gains up to 128, which helps amplify the small differential bridge output signal to make optimal use of the ADC full-scale range. The output signal of the bridge meets the common-mode voltage requirement of the PGA when a symmetrical bridge is used with the excitation voltage equal to the supply voltage of the device.

The maximum input voltage of ADS1220 is limited to  $V_{IN(MAX)} = \pm[(AVDD - AVSS) - 0.4V] / \text{Gain}$ , which means the entire full-scale range,  $FSR = \pm(AVDD - AVSS) / \text{Gain}$ , cannot be used in this configuration. This limitation

is a result of the output drive capability of the PGA amplifiers (A1 and A2); see [Figure 8-2](#). The output of each amplifier must stay 200mV away from the rails (AVDD and AVSS), otherwise the PGA becomes nonlinear. Consequently, the maximum output swing of the PGA is limited to  $V_{OUT} = \pm[(AVDD - AVSS) - 0.4V]$ .

Using a 3mV/V load cell with a 5V excitation yields a maximum differential output voltage of  $V_{INMAX} = \pm 15mV$ , which meets [Equation 40](#) when using a gain of 128.

$$V_{INMAX} \leq \pm[(AVDD - AVSS) - 0.4V] / \text{Gain} = \pm(5V - 0.4V) / 128 = \pm 36mV \quad (40)$$

A first-order differential and common-mode RC filter ( $R_{F1}$ ,  $R_{F2}$ ,  $C_{DIF1}$ ,  $C_{CM1}$ , and  $C_{CM2}$ ) is placed on the ADC inputs. The reference has an additional capacitor  $C_{DIF2}$  to limit reference noise. Care must be taken to maintain a limited amount of filtering or the measurement is no longer ratiometric.

To find the repeatability of the readings, perform the following calculation. The load cell produces an output voltage of 15mV at the maximum load of 1kg. At a Gain = 128 and DR = 20SPS the ADS1220 offers a noise-free resolution of  $0.41\mu V_{pp}$ . The repeatability is then calculated as shown in [Equation 41](#).

$$\text{Repeatability} = (1kg / 15mV) \times 0.41\mu V = 27mg \quad (41)$$

The register settings for this design are shown in [Table 9-6](#).

**Table 9-6. Register Settings**

REGISTER	SETTING	DESCRIPTION
00h	3Eh	$AIN_P = AIN1$ , $AIN_N = AIN2$ , gain = 128, PGA enabled
01h	04h	DR = 20SPS, normal mode, continuous conversion mode
02h	98h	External reference (REFP1, REFN1), simultaneous 50Hz and 60Hz rejection, PSW = 1b
03h	00h	No IDACs used

### 9.3 Power Supply Recommendations

The device requires two power supplies: analog (AVDD, AVSS) and digital (DVDD, DGND). The analog power supply can be bipolar (for example, AVDD = 2.5V, AVSS = -2.5V) or unipolar (for example, AVDD = 3.3V, AVSS = 0V) and is independent of the digital power supply. The digital supply sets the digital I/O levels.

#### 9.3.1 Power-Supply Sequencing

The power supplies can be sequenced in any order, but in no case must any analog or digital inputs exceed the respective analog or digital power-supply voltage and current limits. Ramping DVDD together with or before AVDD minimizes any leakage current through AIN3/REFN1 because of the low-side switch connected to this input. If AVDD ramps before DVDD, then the low-side switch is in an unknown state and can short the AIN3/REFN1 input to AVSS until DVDD has ramped. Wait approximately 50µs after all power supplies are stabilized before communicating with the device to allow the power-up reset process to complete.

#### 9.3.2 Power-Supply Ramp Rate

As shown in Figure 9-12, the power-supply ramp rate must be monotonic and slower than 1V per 50µs for proper device power-up over the entire temperature range.

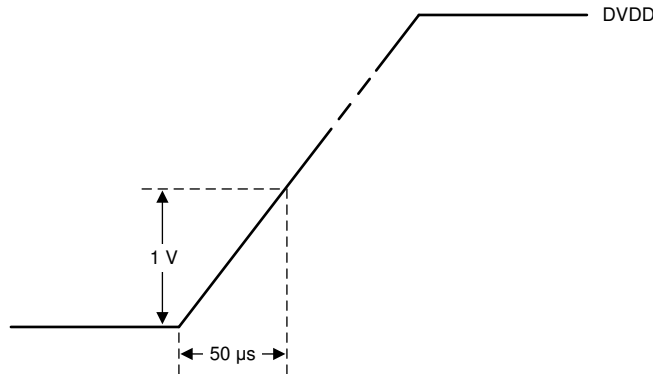


Figure 9-12. Power-Supply Ramp Rate

#### 9.3.3 Power-Supply Decoupling

Good power-supply decoupling is important to achieve optimum performance. AVDD, AVSS (when using a bipolar supply) and DVDD must be decoupled with at least a 0.1µF capacitor, as shown in Figure 9-13 and Figure 9-14. Place the bypass capacitors as close to the power-supply pins of the device as possible using low-impedance connections. Use multilayer ceramic chip capacitors (MLCCs) that offer low equivalent series resistance (ESR) and inductance (ESL) characteristics for power-supply decoupling purposes. For very sensitive systems, or for systems in harsh noise environments, avoiding the use of vias for connecting the capacitors to the device pins can offer good noise immunity. Using multiple vias in parallel lowers the overall inductance and is beneficial for connections to ground planes. Connect analog and digital ground together as close to the device as possible.

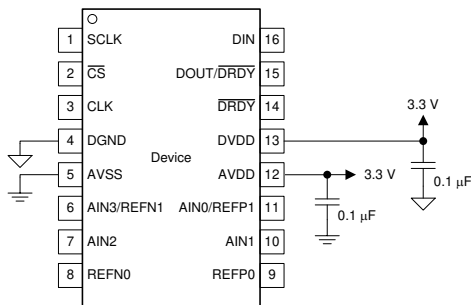


Figure 9-13. Unipolar Analog Power Supply

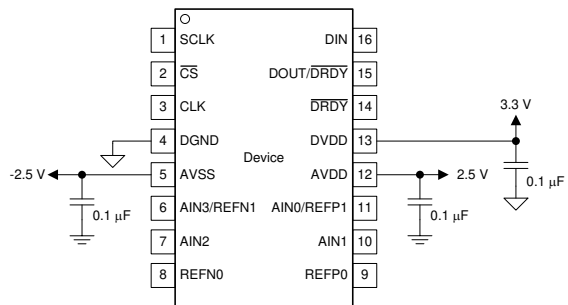
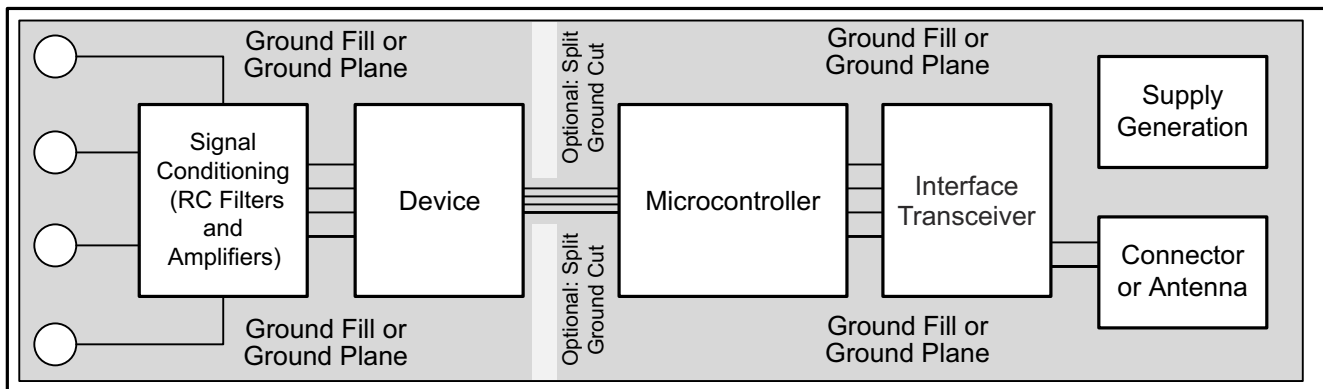


Figure 9-14. Bipolar Analog Power Supply

## 9.4 Layout

### 9.4.1 Layout Guidelines

Use best design practices when laying out a printed circuit board (PCB) for both analog and digital components. This practice generally means that the layout separates analog components [such as ADCs, amplifiers, references, digital-to-analog converters (DACs), and analog MUXs] from digital components [such as microcontrollers, complex programmable logic devices (CPLDs), field-programmable gate arrays (FPGAs), radio frequency (RF) transceivers, universal serial bus (USB) transceivers, and switching regulators]. An example of good component placement is shown in [Figure 9-15](#). Although [Figure 9-15](#) provides a good example of component placement, the best placement for each application is unique to the geometries, components, and PCB fabrication capabilities employed. That is, there is no single layout that is perfect for every design and careful consideration must always be used when designing with any analog component.



**Figure 9-15. System Component Placement**

The use of split analog and digital ground planes is not necessary for improved noise performance (although for thermal isolation this option is a worthwhile consideration). However, the use of a solid ground plane or ground fill in PCB areas with no components is essential for optimum performance. If the system being used employs a split digital and analog ground plane, TI generally recommends that the ground planes be connected together as close to the device as possible. A two-layer board is possible using common grounds for both analog and digital grounds. Additional layers can be added to simplify PCB trace routing. Ground fill can also reduce EMI and RFI issues.

TI also strongly recommends that digital components, especially RF portions, be kept as far as practically possible from analog circuitry in a given system. Additionally, minimize the distance that digital control traces run through analog areas and avoid placing these traces near sensitive analog components. Digital return currents typically flow through a ground path that is as close to the digital path as possible. If a solid ground connection to a plane is not available, these currents can find paths back to the source that interfere with analog performance. The implications that layout has on the temperature-sensing functions are much more significant than for ADC functions.

Supply pins must be bypassed to ground with a low-ESR ceramic capacitor. The optimum placement of the bypass capacitors is as close as possible to the supply pins. If AVSS is connected to a negative supply, then connect an additional bypass capacitor from AVSS to AGND as well. The ground-side connections of the bypass capacitors must be low-impedance connections for optimum performance. The supply current flows through the bypass capacitor terminal first and then to the supply pin to make the bypassing most effective.

Analog inputs with differential connections must have a capacitor placed differentially across the inputs. Best input combinations for differential measurements are AIN0, AIN1 and AIN2, AIN3. The differential capacitors must be of high quality. The best ceramic chip capacitors are C0G (NPO), which have stable properties and low noise characteristics. Thermally isolate a copper region around the thermocouple input connections to create a thermally-stable cold junction. Obtaining acceptable performance with alternate layout schemes is possible as long as the above guidelines are followed.

### 9.4.2 Layout Example

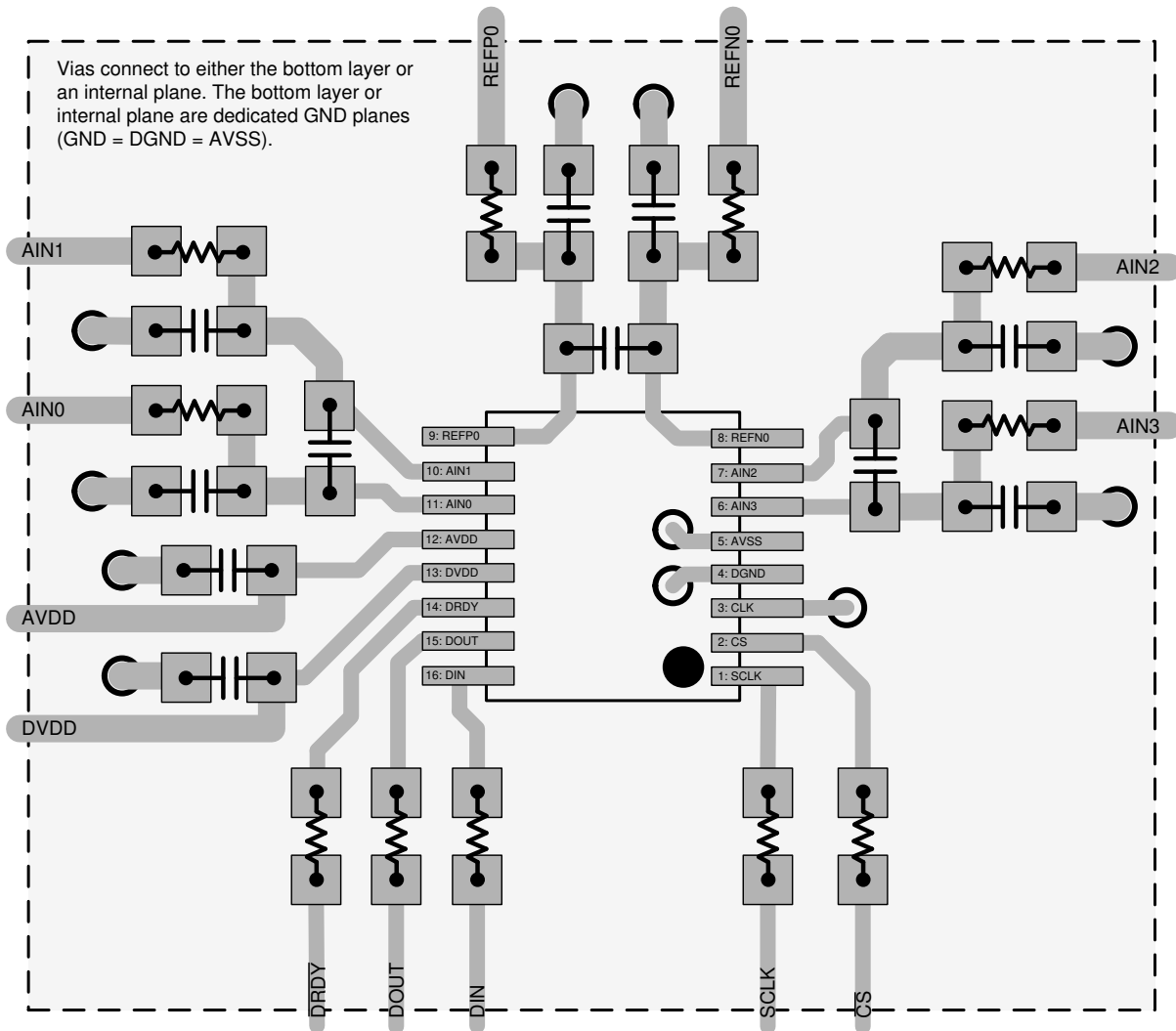


Figure 9-16. Layout Example

## 10 Device and Documentation Support

### 10.1 Documentation Support

#### 10.1.1 Related Documentation

For related documentation see the following:

- Texas Instruments, [REF50xx Low-Noise, Very Low Drift, Precision Voltage Reference data sheet](#)
- Texas Instruments, [RTD Ratiometric Measurements and Filtering Using the ADS1148 and ADS1248 application note](#)

### 10.2 Receiving Notification of Documentation Updates

To receive notification of documentation updates, navigate to the device product folder on [ti.com](http://ti.com). Click on *Notifications* to register and receive a weekly digest of any product information that has changed. For change details, review the revision history included in any revised document.

### 10.3 Support Resources

[TI E2E™ support forums](#) are an engineer's go-to source for fast, verified answers and design help — straight from the experts. Search existing answers or ask your own question to get the quick design help you need.

Linked content is provided "AS IS" by the respective contributors. They do not constitute TI specifications and do not necessarily reflect TI's views; see TI's [Terms of Use](#).

### 10.4 Trademarks

TI E2E™ is a trademark of Texas Instruments.  
All trademarks are the property of their respective owners.

### 10.5 Electrostatic Discharge Caution



This integrated circuit can be damaged by ESD. Texas Instruments recommends that all integrated circuits be handled with appropriate precautions. Failure to observe proper handling and installation procedures can cause damage.

ESD damage can range from subtle performance degradation to complete device failure. Precision integrated circuits may be more susceptible to damage because very small parametric changes could cause the device not to meet its published specifications.

### 10.6 Glossary

[TI Glossary](#) This glossary lists and explains terms, acronyms, and definitions.

## 11 Revision History

NOTE: Page numbers for previous revisions may differ from page numbers in the current version.

### Changes from August 1, 2016 to May 18, 2026 (from Revision C (August 2016) to Revision D (May 2026))

	<b>Page</b>
• Removed <i>Package</i> bullet in <i>Features</i> section.....	1
• Changed <i>Applications</i> bullets on first page.....	1
• Changed <i>Device Information</i> table to <i>Package Information</i> table and added table note in <i>Description</i> section..	1
• Changed <i>K-Type Thermocouple Measurement</i> image in <i>Description</i> section.....	1
• Added <i>Device Comparison</i> table.....	3
• Changed <i>Pin Functions</i> descriptions of AVDD, AVSS, DVDD, and DGND pins.....	4
• Changed V <sub>REF</sub> maximum value from AVDD to AVDD – AVSS in <i>Recommended Operating Conditions</i> table..	6
• Changed SPI timeout from 13955 × t <sub>MOD</sub> to 14000 × t <sub>MOD</sub> for normal mode and duty-cycle mode, and from 27910 × t <sub>MOD</sub> to 28000 × t <sub>MOD</sub> for turbo mode in <i>SPI Timing Requirements</i> table.....	9
• Added <i>Timing Diagrams</i> section.....	9
• Changed <i>ENOB</i> to <i>Effective Resolution</i> , and changed <i>Noise-Free-Bits</i> to <i>Noise-Free Resolution</i> in <i>Noise Performance</i> section.....	16
• Changed <i>Functional Block Diagram</i> figure.....	19

• Changed first and third paragraphs in <i>Multiplexer</i> section.....	20
• Changed first paragraph and added <i>Gain Implementation</i> table in <i>Low-Noise PGA</i> section .....	21
• Changed first sentence in <i>Bypassing the PGA</i> section.....	25
• Changed last sentence in the second paragraph in <i>Bypassing the PGA</i> section describing the device behavior while using PGA_BYPASS and gains greater than 4.....	25
• Changed the location of the <i>Voltage Reference</i> and <i>Clock Source</i> sections.....	26
• Changed first paragraph in <i>Digital Filter</i> section.....	27
• Changed <i>Turbo Mode, 40 SPS, -3dB Bandwidth Hz</i> from 26.2 to 17.1 in <i>Conversion Times</i> table in <i>Output Data Rate</i> section.....	30
• Changed first and second paragraph in <i>Excitation Current Sources</i> section.....	31
• Changed first paragraph in <i>System Monitor</i> section.....	32
• Changed first paragraph and examples in <i>Converting from Digital Codes to Temperature</i> section.....	33
• Added <i>14-Bit Temperature Sensor Data Alignment Within 24-Bit Conversion Result</i> figure in <i>Converting From Digital Codes to Temperature</i> section.....	33
• Removed <i>Converting From Temperature to Digital codes</i> section.....	33
• Changed the name of the <i>Single-Shot Mode</i> section to <i>Single-Shot Conversion Mode</i> .....	34
• Changed second paragraph in <i>Data Output and Data Ready (DOUT/DRDY)</i> section.....	36
• Changed timeout period from $13955 \times t_{MOD}$ to $14000 \times t_{MOD}$ for normal mode and duty-cycle mode, and from $27910 \times t_{MOD}$ to $28000 \times t_{MOD}$ for turbo mode in <i>SPI Timeout</i> section.....	36
• Added note after <i>Code Transition Diagram</i> in <i>Data Format</i> section.....	37
• Changed bit setting notation from hexadecimal to binary where beneficial throughout <i>Register Map</i> section.....	42
• Added <i>Register Descriptions</i> section and <i>Register Access Type Codes</i> table to <i>Register Map</i> section.....	42
• Changed bit 0 in register 03h from 0 to RESERVED.....	46
• Changed third and fourth paragraphs in <i>Detailed Design Procedure</i> in <i>K-Type Thermocouple Measurement</i> section.....	52

### Changes from Revision B (February 2015) to Revision C (August 2016)

Page

• Changed <i>K-Type Thermocouple Measurement</i> figure.....	1
• Added footnote 1 to <i>Pin Functions</i> table and changed descriptions of AIN0/REFP1, AIN1, AIN2, AIN3/REFN1, REFN0, and REFP0 pins accordingly.....	4
• Changed <i>Functional Block Diagram</i> figure.....	19
• Changed <i>Bypassing the PGA</i> section.....	25
• Added fourth sentence to <i>Temperature Sensor</i> section.....	33
• Changed last equation in <i>Converting from Digital Codes to Temperature</i> section.....	33
• Changed description of bits 5:4 in <a href="#">Configuration Register 2</a> .....	45
• Added <i>Unused Inputs and Outputs</i> section .....	50
• Changed <a href="#">Figure 9-3</a> .....	52
• Changed <a href="#">Figure 9-6</a> .....	55
• Changed <a href="#">Figure 9-7</a> .....	59
• Changed <a href="#">Figure 9-8</a> .....	59
• Changed <a href="#">Figure 9-11</a> .....	62
• Changed <i>Power Supply Recommendations</i> section: changed <i>Power-Supply Sequencing</i> subsection, added <i>Power-Supply Ramp Rate</i> subsection.....	64

## 12 Mechanical, Packaging, and Orderable Information

The following pages include mechanical, packaging, and orderable information. This information is the most current data available for the designated devices. This data is subject to change without notice and revision of this document. For browser-based versions of this data sheet, refer to the left-hand navigation.

**PACKAGING INFORMATION**

Orderable part number	Status (1)	Material type (2)	Package   Pins	Package qty   Carrier	RoHS (3)	Lead finish/ Ball material (4)	MSL rating/ Peak reflow (5)	Op temp (°C)	Part marking (6)
<a href="#">ADS1220IPW</a>	Active	Production	TSSOP (PW)   16	90   TUBE	Yes	NIPDAU	Level-2-260C-1 YEAR	-40 to 125	ADS1220
ADS1220IPW.A	Active	Production	TSSOP (PW)   16	90   TUBE	Yes	NIPDAU	Level-2-260C-1 YEAR	-40 to 125	ADS1220
ADS1220IPW.B	Active	Production	TSSOP (PW)   16	90   TUBE	Yes	NIPDAU	Level-2-260C-1 YEAR	-40 to 125	ADS1220
<a href="#">ADS1220IPWR</a>	Active	Production	TSSOP (PW)   16	2500   LARGE T&R	Yes	NIPDAU	Level-2-260C-1 YEAR	-40 to 125	ADS1220
ADS1220IPWR.A	Active	Production	TSSOP (PW)   16	2500   LARGE T&R	Yes	NIPDAU	Level-2-260C-1 YEAR	-40 to 125	ADS1220
ADS1220IPWR.B	Active	Production	TSSOP (PW)   16	2500   LARGE T&R	Yes	NIPDAU	Level-2-260C-1 YEAR	-40 to 125	ADS1220
ADS1220IPWRG4	Active	Production	TSSOP (PW)   16	2500   LARGE T&R	Yes	NIPDAU	Level-2-260C-1 YEAR	-40 to 125	ADS1220
ADS1220IPWRG4.A	Active	Production	TSSOP (PW)   16	2500   LARGE T&R	Yes	NIPDAU	Level-2-260C-1 YEAR	-40 to 125	ADS1220
ADS1220IPWRG4.B	Active	Production	TSSOP (PW)   16	2500   LARGE T&R	Yes	NIPDAU	Level-2-260C-1 YEAR	-40 to 125	ADS1220
<a href="#">ADS1220IRVAR</a>	Active	Production	VQFN (RVA)   16	3000   LARGE T&R	Yes	NIPDAU	Level-1-260C-UNLIM	-40 to 125	1220
ADS1220IRVAR.A	Active	Production	VQFN (RVA)   16	3000   LARGE T&R	Yes	NIPDAU	Level-1-260C-UNLIM	-40 to 125	1220
ADS1220IRVAR.B	Active	Production	VQFN (RVA)   16	3000   LARGE T&R	Yes	NIPDAU	Level-1-260C-UNLIM	-40 to 125	1220
ADS1220IRVARG4	Active	Production	VQFN (RVA)   16	3000   LARGE T&R	Yes	NIPDAU	Level-1-260C-UNLIM	-40 to 125	1220
ADS1220IRVARG4.A	Active	Production	VQFN (RVA)   16	3000   LARGE T&R	Yes	NIPDAU	Level-1-260C-UNLIM	-40 to 125	1220
ADS1220IRVARG4.B	Active	Production	VQFN (RVA)   16	3000   LARGE T&R	Yes	NIPDAU	Level-1-260C-UNLIM	-40 to 125	1220
<a href="#">ADS1220IRVAT</a>	Active	Production	VQFN (RVA)   16	250   SMALL T&R	Yes	NIPDAU	Level-2-260C-1 YEAR	-40 to 125	1220
ADS1220IRVAT.A	Active	Production	VQFN (RVA)   16	250   SMALL T&R	Yes	NIPDAU	Level-2-260C-1 YEAR	-40 to 125	1220
ADS1220IRVAT.B	Active	Production	VQFN (RVA)   16	250   SMALL T&R	Yes	NIPDAU	Level-2-260C-1 YEAR	-40 to 125	1220

(1) **Status:** For more details on status, see our [product life cycle](#).

(2) **Material type:** When designated, preproduction parts are prototypes/experimental devices, and are not yet approved or released for full production. Testing and final process, including without limitation quality assurance, reliability performance testing, and/or process qualification, may not yet be complete, and this item is subject to further changes or possible discontinuation. If available for ordering, purchases will be subject to an additional waiver at checkout, and are intended for early internal evaluation purposes only. These items are sold without warranties of any kind.

(3) **RoHS values:** Yes, No, RoHS Exempt. See the [TI RoHS Statement](#) for additional information and value definition.

(4) **Lead finish/Ball material:** Parts may have multiple material finish options. Finish options are separated by a vertical ruled line. Lead finish/Ball material values may wrap to two lines if the finish value exceeds the maximum column width.

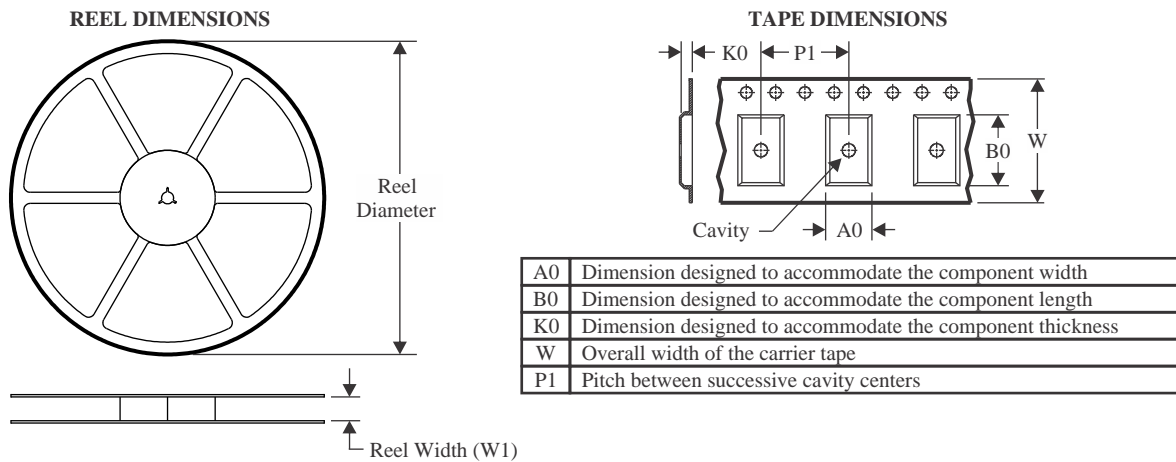
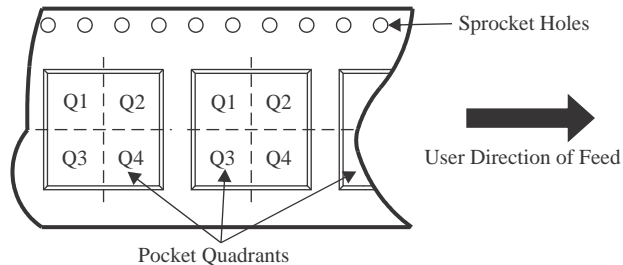
(5) **MSL rating/Peak reflow:** The moisture sensitivity level ratings and peak solder (reflow) temperatures. In the event that a part has multiple moisture sensitivity ratings, only the lowest level per JEDEC standards is shown. Refer to the shipping label for the actual reflow temperature that will be used to mount the part to the printed circuit board.

(6) **Part marking:** There may be an additional marking, which relates to the logo, the lot trace code information, or the environmental category of the part.

Multiple part markings will be inside parentheses. Only one part marking contained in parentheses and separated by a "~" will appear on a part. If a line is indented then it is a continuation of the previous line and the two combined represent the entire part marking for that device.

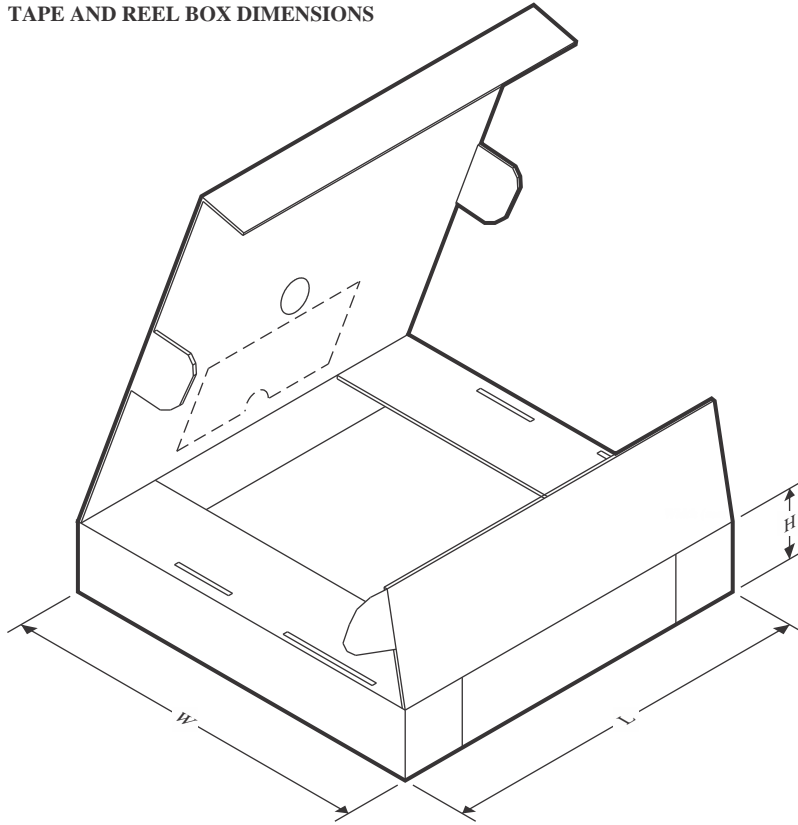
**Important Information and Disclaimer:**The information provided on this page represents TI's knowledge and belief as of the date that it is provided. TI bases its knowledge and belief on information provided by third parties, and makes no representation or warranty as to the accuracy of such information. Efforts are underway to better integrate information from third parties. TI has taken and continues to take reasonable steps to provide representative and accurate information but may not have conducted destructive testing or chemical analysis on incoming materials and chemicals. TI and TI suppliers consider certain information to be proprietary, and thus CAS numbers and other limited information may not be available for release.

In no event shall TI's liability arising out of such information exceed the total purchase price of the TI part(s) at issue in this document sold by TI to Customer on an annual basis.

**TAPE AND REEL INFORMATION**

**QUADRANT ASSIGNMENTS FOR PIN 1 ORIENTATION IN TAPE**


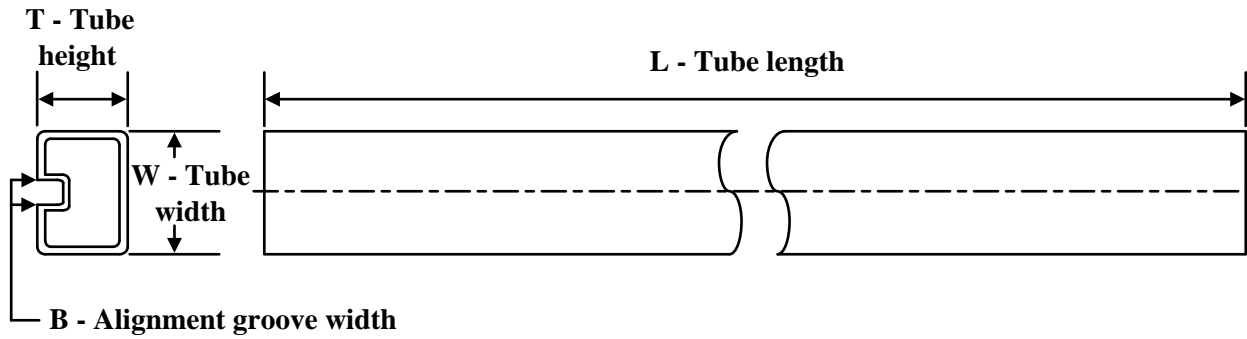
\*All dimensions are nominal

Device	Package Type	Package Drawing	Pins	SPQ	Reel Diameter (mm)	Reel Width W1 (mm)	A0 (mm)	B0 (mm)	K0 (mm)	P1 (mm)	W (mm)	Pin1 Quadrant
ADS1220IPWR	TSSOP	PW	16	2500	330.0	12.4	6.9	5.6	1.6	8.0	12.0	Q1
ADS1220IPWRG4	TSSOP	PW	16	2500	330.0	12.4	6.9	5.6	1.6	8.0	12.0	Q1
ADS1220IRVAR	VQFN	RVA	16	3000	330.0	12.4	3.75	3.75	1.15	8.0	12.0	Q2
ADS1220IRVARG4	VQFN	RVA	16	3000	330.0	12.4	3.75	3.75	1.15	8.0	12.0	Q2
ADS1220IRVAT	VQFN	RVA	16	250	180.0	12.4	3.75	3.75	1.15	8.0	12.0	Q2

**TAPE AND REEL BOX DIMENSIONS**


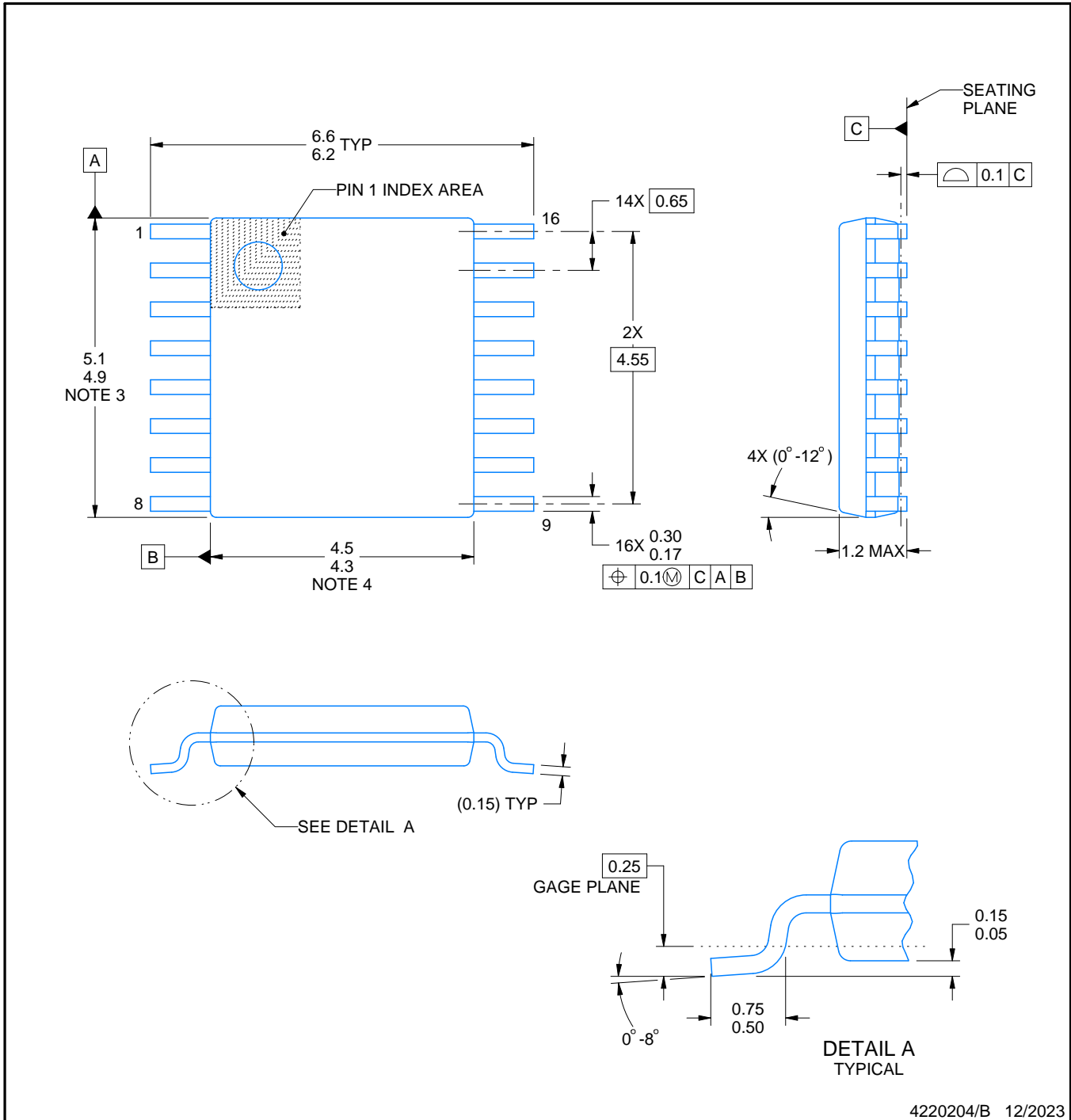
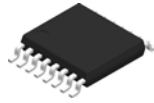
\*All dimensions are nominal

Device	Package Type	Package Drawing	Pins	SPQ	Length (mm)	Width (mm)	Height (mm)
ADS1220IPWR	TSSOP	PW	16	2500	353.0	353.0	32.0
ADS1220IPWRG4	TSSOP	PW	16	2500	353.0	353.0	32.0
ADS1220IRVAR	VQFN	RVA	16	3000	346.0	346.0	33.0
ADS1220IRVARG4	VQFN	RVA	16	3000	346.0	346.0	33.0
ADS1220IRVAT	VQFN	RVA	16	250	210.0	185.0	35.0

**TUBE**


\*All dimensions are nominal

Device	Package Name	Package Type	Pins	SPQ	L (mm)	W (mm)	T (μm)	B (mm)
ADS1220IPW	PW	TSSOP	16	90	530	10.2	3600	3.5
ADS1220IPW.A	PW	TSSOP	16	90	530	10.2	3600	3.5
ADS1220IPW.B	PW	TSSOP	16	90	530	10.2	3600	3.5



4220204/B 12/2023

NOTES:

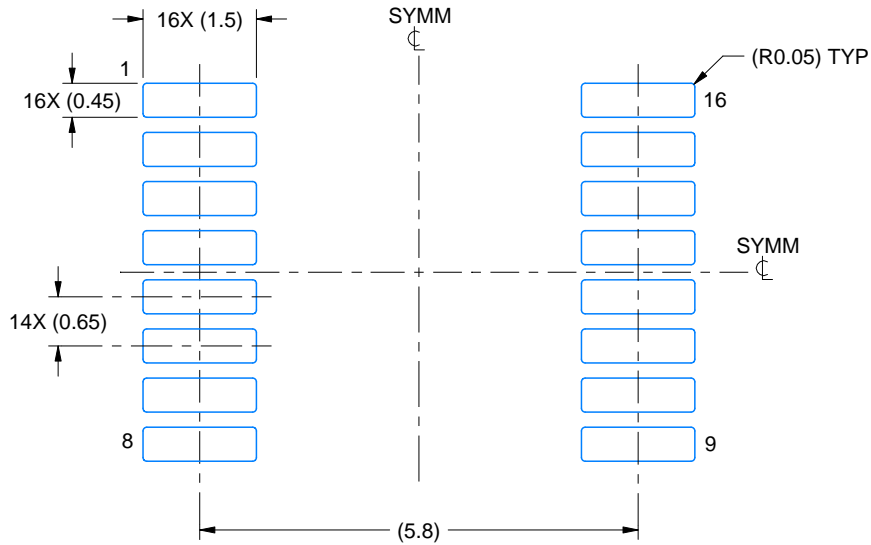
1. All linear dimensions are in millimeters. Any dimensions in parenthesis are for reference only. Dimensioning and tolerancing per ASME Y14.5M.
2. This drawing is subject to change without notice.
3. This dimension does not include mold flash, protrusions, or gate burrs. Mold flash, protrusions, or gate burrs shall not exceed 0.15 mm per side.
4. This dimension does not include interlead flash. Interlead flash shall not exceed 0.25 mm per side.
5. Reference JEDEC registration MO-153.

# EXAMPLE BOARD LAYOUT

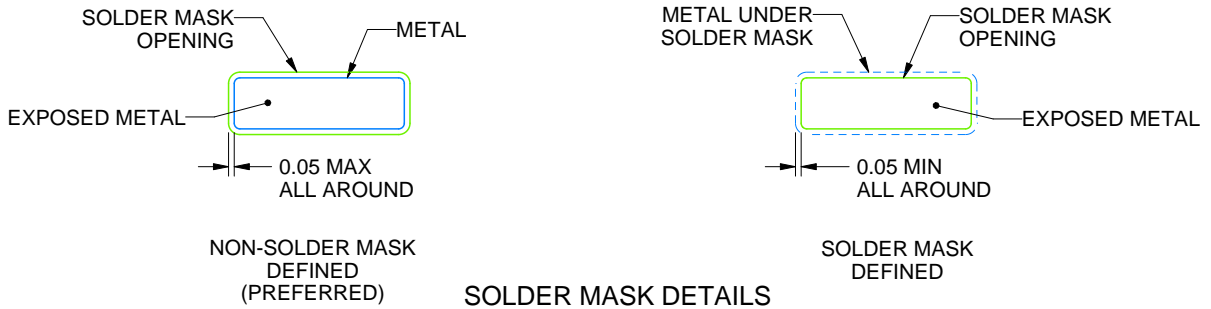
PW0016A

TSSOP - 1.2 mm max height

SMALL OUTLINE PACKAGE



LAND PATTERN EXAMPLE  
EXPOSED METAL SHOWN  
SCALE: 10X



SOLDER MASK DETAILS

4220204/B 12/2023

NOTES: (continued)

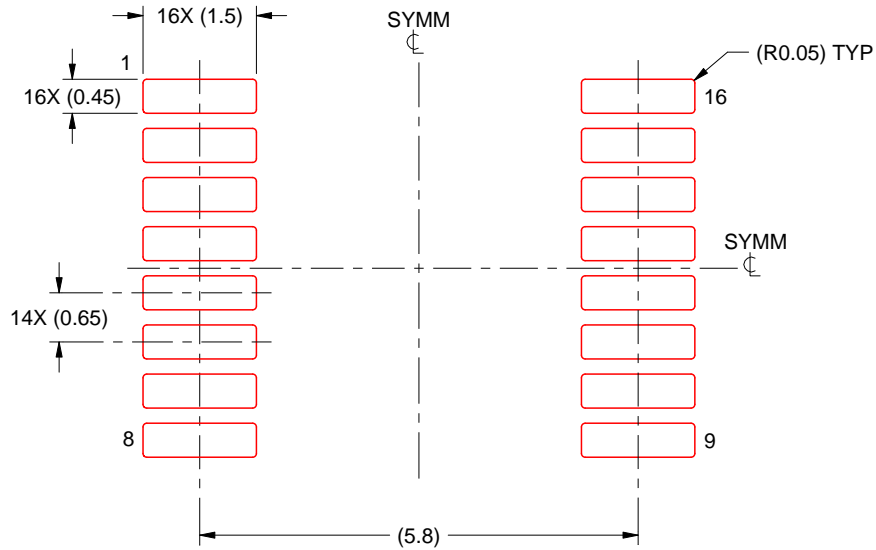
- 6. Publication IPC-7351 may have alternate designs.
- 7. Solder mask tolerances between and around signal pads can vary based on board fabrication site.

# EXAMPLE STENCIL DESIGN

PW0016A

TSSOP - 1.2 mm max height

SMALL OUTLINE PACKAGE



SOLDER PASTE EXAMPLE  
BASED ON 0.125 mm THICK STENCIL  
SCALE: 10X

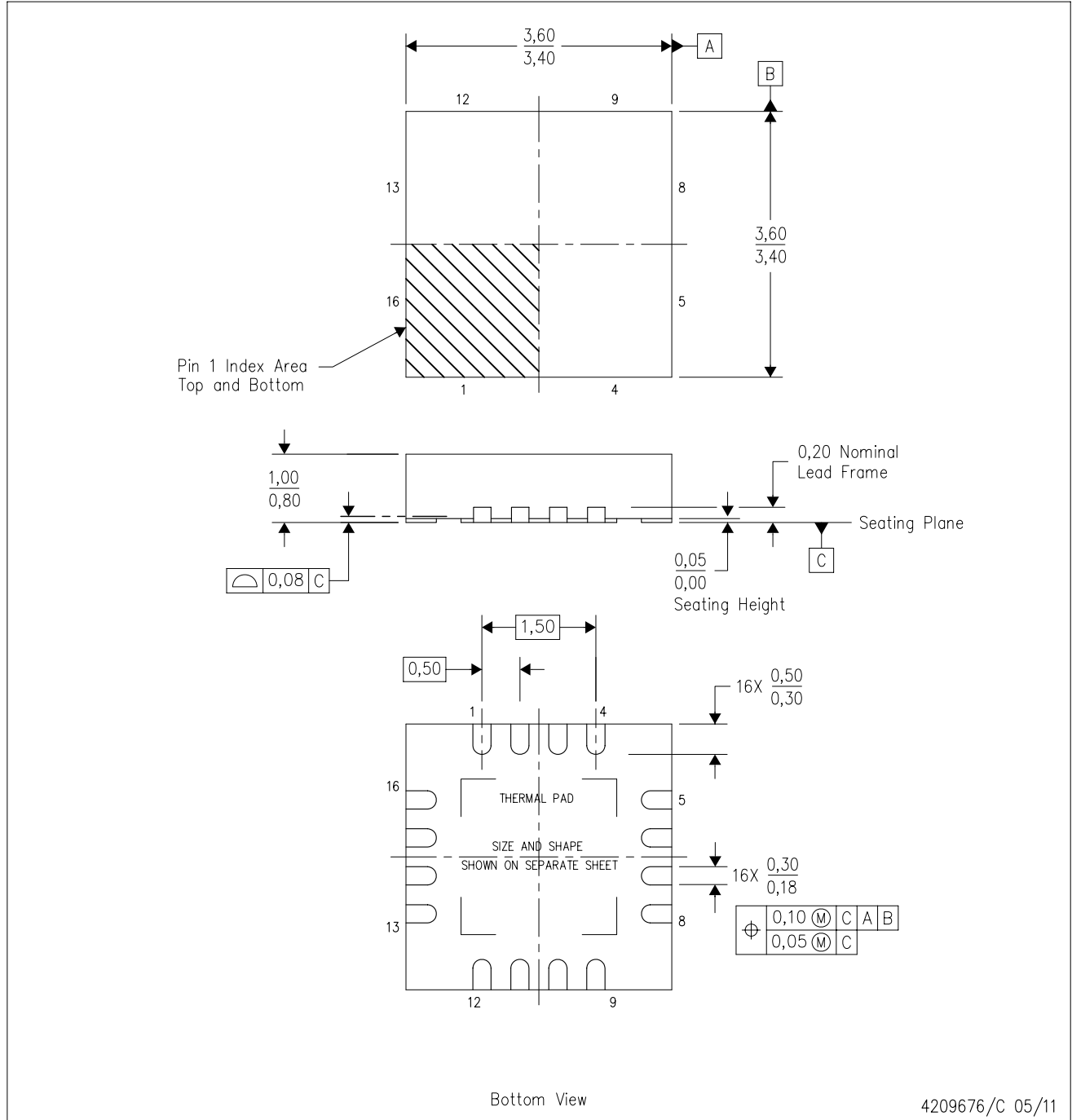
4220204/B 12/2023

NOTES: (continued)

8. Laser cutting apertures with trapezoidal walls and rounded corners may offer better paste release. IPC-7525 may have alternate design recommendations.
9. Board assembly site may have different recommendations for stencil design.

RVA (S-PVQFN-N16)

PLASTIC QUAD FLATPACK NO-LEAD



Bottom View

4209676/C 05/11

- NOTES:
- All linear dimensions are in millimeters. Dimensioning and tolerancing per ASME Y14.5M-1994.
  - This drawing is subject to change without notice.
  - QFN (Quad Flatpack No-Lead) package configuration.
  - The package thermal pad must be soldered to the board for thermal and mechanical performance.
  - See the additional figure in the Product Data Sheet for details regarding the exposed thermal pad features and dimensions.

## THERMAL PAD MECHANICAL DATA

RVA (S-PVQFN-N16)

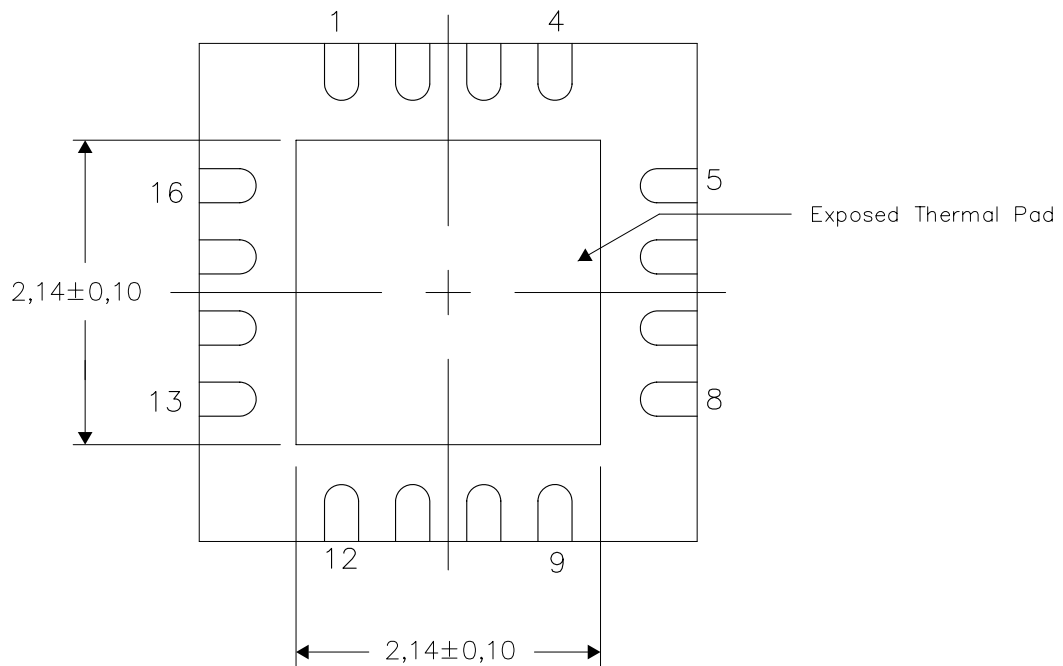
PLASTIC QUAD FLATPACK NO-LEAD

### THERMAL INFORMATION

This package incorporates an exposed thermal pad that is designed to be attached directly to an external heatsink. The thermal pad must be soldered directly to the printed circuit board (PCB). After soldering, the PCB can be used as a heatsink. In addition, through the use of thermal vias, the thermal pad can be attached directly to the appropriate copper plane shown in the electrical schematic for the device, or alternatively, can be attached to a special heatsink structure designed into the PCB. This design optimizes the heat transfer from the integrated circuit (IC).

For information on the Quad Flatpack No-Lead (QFN) package and its advantages, refer to Application Report, QFN/SON PCB Attachment, Texas Instruments Literature No. SLUA271. This document is available at [www.ti.com](http://www.ti.com).

The exposed thermal pad dimensions for this package are shown in the following illustration.

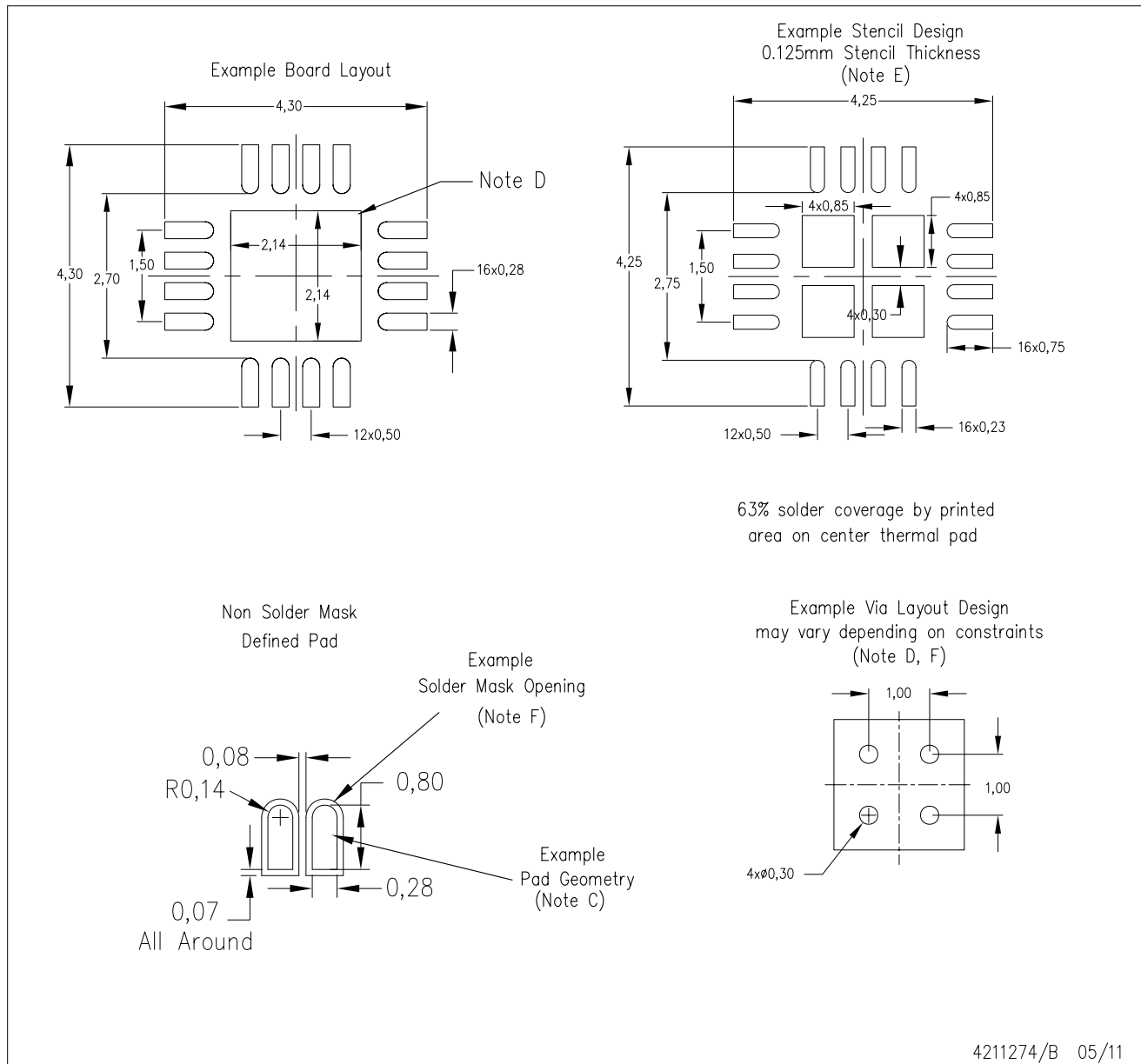


4209715/B 05/11

NOTE: All linear dimensions are in millimeters

RVA (S-PVQFN-N16)

PLASTIC QUAD FLATPACK NO-LEAD



- NOTES:
- A. All linear dimensions are in millimeters.
  - B. This drawing is subject to change without notice.
  - C. Publication IPC-7351 is recommended for alternate designs.
  - D. This package is designed to be soldered to a thermal pad on the board. Refer to Application Note, Quad Flat-Pack QFN/SON PCB Attachment, Texas Instruments Literature No. SLUA271, and also the Product Data Sheets for specific thermal information, via requirements, and recommended board layout. These documents are available at [www.ti.com](http://www.ti.com) <<http://www.ti.com>>.
  - E. Laser cutting apertures with trapezoidal walls and also rounding corners will offer better paste release. Customers should contact their board assembly site for stencil design recommendations. Refer to IPC 7525 for stencil design considerations.
  - F. Customers should contact their board fabrication site for minimum solder mask web tolerances between signal pads.

## IMPORTANT NOTICE AND DISCLAIMER

TI PROVIDES TECHNICAL AND RELIABILITY DATA (INCLUDING DATASHEETS), DESIGN RESOURCES (INCLUDING REFERENCE DESIGNS), APPLICATION OR OTHER DESIGN ADVICE, WEB TOOLS, SAFETY INFORMATION, AND OTHER RESOURCES "AS IS" AND WITH ALL FAULTS, AND DISCLAIMS ALL WARRANTIES, EXPRESS AND IMPLIED, INCLUDING WITHOUT LIMITATION ANY IMPLIED WARRANTIES OF MERCHANTABILITY, FITNESS FOR A PARTICULAR PURPOSE OR NON-INFRINGEMENT OF THIRD PARTY INTELLECTUAL PROPERTY RIGHTS.

These resources are intended for skilled developers designing with TI products. You are solely responsible for (1) selecting the appropriate TI products for your application, (2) designing, validating and testing your application, and (3) ensuring your application meets applicable standards, and any other safety, security, regulatory or other requirements.

These resources are subject to change without notice. TI grants you permission to use these resources only for development of an application that uses the TI products described in the resource. Other reproduction and display of these resources is prohibited. No license is granted to any other TI intellectual property right or to any third party intellectual property right. TI disclaims responsibility for, and you fully indemnify TI and its representatives against any claims, damages, costs, losses, and liabilities arising out of your use of these resources.

TI's products are provided subject to [TI's Terms of Sale](#), [TI's General Quality Guidelines](#), or other applicable terms available either on [ti.com](http://ti.com) or provided in conjunction with such TI products. TI's provision of these resources does not expand or otherwise alter TI's applicable warranties or warranty disclaimers for TI products. Unless TI explicitly designates a product as custom or customer-specified, TI products are standard, catalog, general purpose devices.

TI objects to and rejects any additional or different terms you may propose.

Copyright © 2026, Texas Instruments Incorporated

Last updated 10/2025