

## AMC80 System Hardware Monitor with Two-Wire and SMBus Serial Interface

### 1 Features

- 10-Bit ADC With Seven Analog Inputs
- Fan-Speed Monitoring Inputs
- Input Range/Resolution:
  - Default: 2.56 V/2.5 mV
  - Programmable:  $V_{DD}/6$  mV
- Chassis Intrusion Detection Input
- Interrupt Alarms:
  - Upper Over-Limit
  - Lower Under-Limit
- Interrupt Status Register Input for External Temperature Sensors
- Shutdown Mode
- Programmable  $\overline{\text{RST\_OUT/OS}}$
- Pin Compatible with LM96080 and LM80
- Package: 24-Pin TSSOP

### 2 Applications

- Communications Equipment
- Servers
- Industrial and Medical Equipment
- Storage Area Networks
- Set-Top Boxes
- Test and Measurement Equipment

### 3 Description

The AMC80 is a system hardware monitoring and control circuit that includes a seven-channel, 10-bit analog-to-digital converter (ADC), two programmable fan-speed monitors, and a two-wire interface. The AMC80 also includes programmable upper over-limit and lower under-limit alarms that activate when the programmed limits are exceeded.

The AMC80 can interface with both linear and digital temperature sensors. The 2.5-mV least significant bit (LSB) and 2.56-V input range can accept inputs from a linear sensor such as the [TMP20](#). The  $\overline{\text{BTI}}$  pin is used as an input from a digital sensor such as the [TMP75](#). The AMC80 operates from a 3-V to 5.5-V supply voltage, has low supply current, and can be configured using a two-wire interface, thus making it ideal for a wide range of applications.

The AMC80 is available in a 24-lead TSSOP package and is fully specified over the  $-40^{\circ}\text{C}$  to  $+125^{\circ}\text{C}$  temperature range.

#### Device Information<sup>(1)</sup>

PART NUMBER	PACKAGE	BODY SIZE (NOM)
AMC80	TSSOP (24)	7.80 mm x 4.40 mm

(1) For all available packages, see the package option addendum at the end of the data sheet.

#### Simplified Schematic

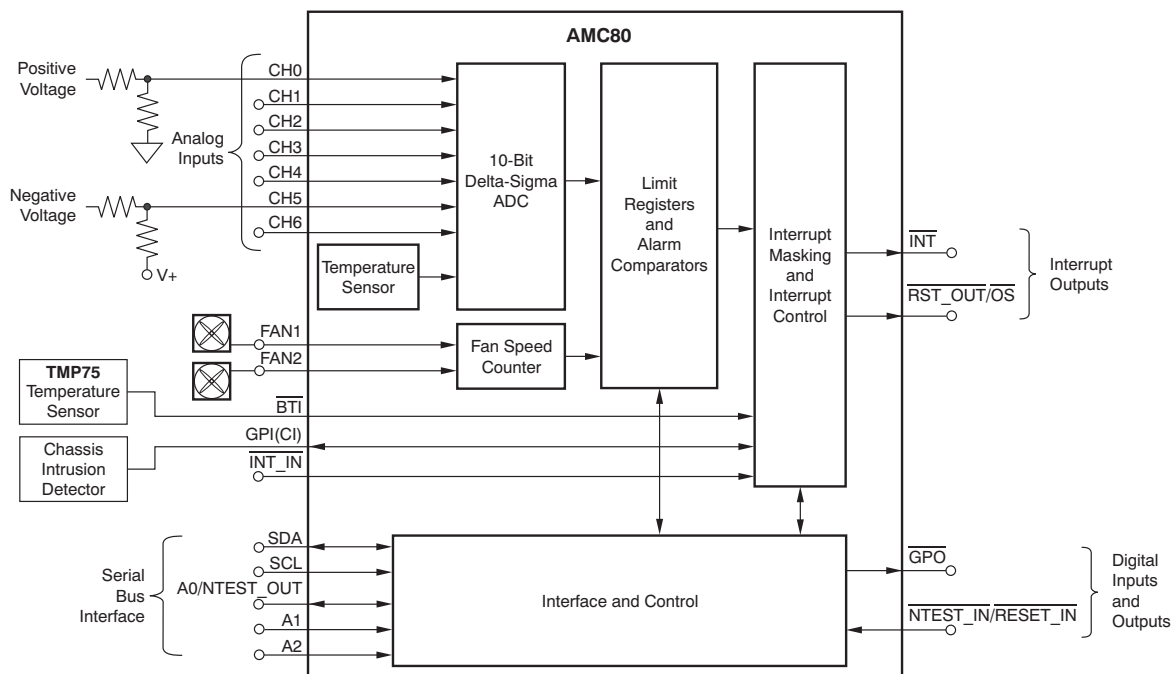

## Table of Contents

<b>1 Features</b> .....	<b>1</b>	7.1 Overview .....	10
<b>2 Applications</b> .....	<b>1</b>	7.2 Functional Block Diagram .....	10
<b>3 Description</b> .....	<b>1</b>	7.3 Feature Description .....	10
<b>4 Revision History</b> .....	<b>2</b>	7.4 Programming .....	14
<b>5 Pin Configuration and Functions</b> .....	<b>3</b>	7.5 Register Map .....	16
<b>6 Specifications</b> .....	<b>5</b>	<b>8 Application and Implementation</b> .....	<b>21</b>
6.1 Absolute Maximum Ratings .....	5	8.1 Application Information .....	21
6.2 ESD Ratings .....	5	<b>9 Device and Documentation Support</b> .....	<b>23</b>
6.3 Recommended Operating Conditions .....	5	9.1 Community Resources .....	23
6.4 Thermal Information .....	5	9.2 Trademarks .....	23
6.5 Electrical Characteristics .....	6	9.3 Electrostatic Discharge Caution .....	23
6.6 Timing Requirements .....	8	9.4 Glossary .....	23
6.7 Typical Characteristics .....	9	<b>10 Mechanical, Packaging, and Orderable Information</b> .....	<b>23</b>
<b>7 Detailed Description</b> .....	<b>10</b>		

## 4 Revision History

<b>Changes from Revision A (January 2012) to Revision B</b>	<b>Page</b>
• Changed INT pin description .....	4
• Added pins to input voltage range in <i>Absolute Maximum Ratings</i> table .....	5
• Added <i>ESD Ratings</i> table .....	5
• Added new note 1 to <i>Timing Requirements</i> table .....	8
• Added <i>Detailed Description</i> section .....	10
• Added <i>Application and Implementation</i> section .....	21
• Added <i>Device and Documentation Support</i> section .....	23

<b>Changes from Original (May 2011) to Revision A</b>	<b>Page</b>
• Added SMBus timeout parameter to Electrical Characteristics .....	6
• Changed Bit 0 = '1' in <a href="#">Table 10</a> .....	18

## 5 Pin Configuration and Functions

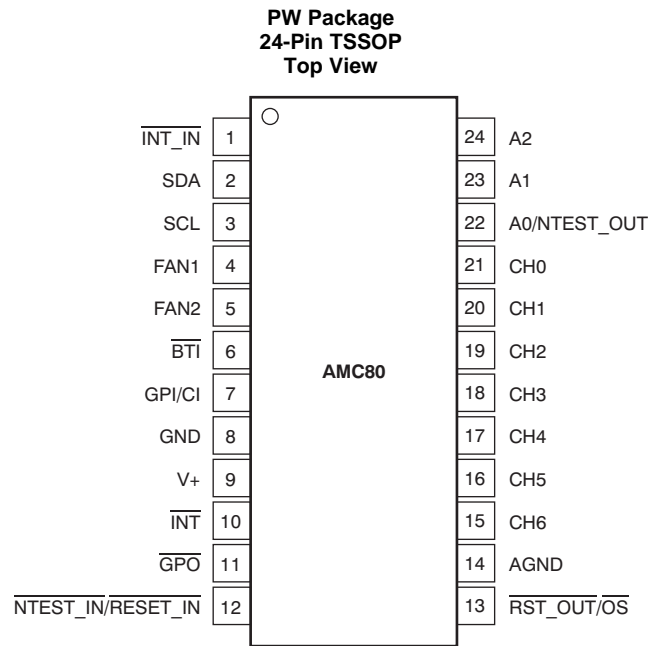

### Pin Functions

PIN		I/O	TYPE	DESCRIPTION
NO.	NAME			
1	$\overline{\text{INT\_IN}}$	Input	Digital	Interrupt input pin. An active low input that extends the $\overline{\text{INT\_IN}}$ signal to the $\overline{\text{INT}}$ output of the AMC80.
2	SDA	I/O	Digital	Serial bus data line for SMBus, open-drain; requires pull-up resistor.
3	SCL	I/O	Digital	Serial bus clock line for SMBus, open-drain; requires pull-up resistor.
4	FAN1	Input	Digital	Fan tachometer input pin
5	FAN2	Input	Digital	Fan tachometer input pin
6	$\overline{\text{BTI}}$	Input	Digital	Board temperature interrupt pin. $\overline{\text{BTI}}$ is driven by the over-temperature shutdown (OS) outputs of the additional temperature sensors. This pin has an internal 10-k $\Omega$ pull-up resistor.
7	GPI(CI)	Input	Digital	General-purpose input pin (chassis interrupt). An active high interrupt input pin to latch a chassis interrupt event.
8	DGND	Power	Analog	Digital ground.
9	V+	Power	Analog	Positive supply voltage (3V to 5.5V).
10	$\overline{\text{INT}}$	Output	Digital	Non-maskable interrupt (active high, PMOS, push-pull) or interrupt request (active low, NMOS, push-pull) pin. The $\overline{\text{INT}}$ pin becomes active when $\overline{\text{INT\_IN}}$ , $\overline{\text{BTI}}$ , or GPI interrupts. This pin does not require a pullup resistor to V+.
11	$\overline{\text{GPO}}$	Output	Digital	General-purpose output pin. $\overline{\text{GPO}}$ is an active low, NMOS, open-drain output. This pin is intended to drive an external power PMOS for software power control or to control power to a cooling fan.
12	$\overline{\text{NTEST\_IN/RESET\_IN}}$	Input	Digital	This pin is an active-low input that enables NAND tree board-level connectivity testing. The AMC80 resets to its power-on state when NAND tree connectivity is enabled.
13	$\overline{\text{RST\_OUT/OS}}$	Output	Digital	This pin is an NMOS open-drain output. $\overline{\text{RST\_OUT}}$ provides a master reset to devices connected to this line. $\overline{\text{OS}}$ is dedicated to the temperature reading alarm.
14	AGND	Power	Analog	Analog ground. This pin must be tied to a low-noise analog ground plane for optimum performance.
15	CH6	Input	Analog	Analog input channel 6
16	CH5	Input	Analog	Analog input channel 5
17	CH4	Input	Analog	Analog input channel 4
18	CH3	Input	Analog	Analog input channel 3
19	CH2	Input	Analog	Analog input channel 2
20	CH1	Input	Analog	Analog input channel 1
21	CH0	Input	Analog	Analog input channel 0
22	A0/NTEST_OUT	I/O	Digital	The lowest order bit of the serial bus address. During a NAND tree test for ATE board-level connectivity, this pin functions as an output.
23	A1	Input	Digital	Address pin 1
24	A2	Input	Digital	Address pin 2

## 6 Specifications

### 6.1 Absolute Maximum Ratings<sup>(1)</sup>

Over operating free-air temperature range, unless otherwise noted.

		MIN	MAX	UNIT
Power-supply voltage range, V+		-0.3	7	V
Input voltage range, V <sub>IN</sub>	Pins 6, 10, 15, 16, 17, 18, 19, 20, 21, 22, 24	-0.3	(V+) + 0.3	V
	Pins 1, 2, 3, 4, 5, 7, 9, 11, 12, 13, 23	-0.3	7	
Input current, I <sub>IN</sub>			10	mA
Operating temperature range, T <sub>A</sub>		-55	127	°C
Junction temperature range, T <sub>J</sub> max			150	°C
Storage temperature range, T <sub>STG</sub>		-65	150	°C

- (1) Stresses above these ratings may cause permanent damage. Exposure to absolute maximum conditions for extended periods may degrade device reliability. These are stress ratings only, and functional operation of the device at these or any other conditions beyond those specified is not implied.

### 6.2 ESD Ratings

		VALUE	UNIT
V <sub>(ESD)</sub> Electrostatic discharge	Human-body model (HBM), per ANSI/ESDA/JEDEC JS-001 <sup>(1)</sup>	±2500	V
	Charged-device model (CDM), per JEDEC specification JESD22-C101 <sup>(2)</sup>	±1000	
	Machine model (MM)	±200	

- (1) JEDEC document JEP155 states that 500-V HBM allows safe manufacturing with a standard ESD control process.  
(2) JEDEC document JEP157 states that 250-V CDM allows safe manufacturing with a standard ESD control process.

### 6.3 Recommended Operating Conditions

		MIN	NOM	MAX	UNIT
Supply voltage range, V+		3		5.5	V
Input voltage range, V <sub>IN</sub>		-0.05		(V+) + 0.05	V
Operating temperature range, T <sub>A</sub>		-40		125	°C

### 6.4 Thermal Information

THERMAL METRIC <sup>(1)</sup>		AMC80	UNIT
		PW (TSSOP)	
		24 PINS	
R <sub>θJA</sub>	Junction-to-ambient thermal resistance	100.72	°C/W
R <sub>θJC(top)</sub>	Junction-to-case (top) thermal resistance	31.4	°C/W
R <sub>θJB</sub>	Junction-to-board thermal resistance	54.7	°C/W
Ψ <sub>JT</sub>	Junction-to-top characterization parameter	1.0	°C/W
Ψ <sub>JB</sub>	Junction-to-board characterization parameter	54.2	°C/W
R <sub>θJC(bot)</sub>	Junction-to-case (bottom) thermal resistance	N/A	°C/W

- (1) For more information about traditional and new thermal metrics, see the *Semiconductor and IC Package Thermal Metrics* application report, [SPRA953](#).

## 6.5 Electrical Characteristics

 At  $T_A$   $-40^{\circ}\text{C}$  to  $+125^{\circ}\text{C}$  and  $V_+ = 3\text{ V}$  to  $5.5\text{ V}$ , unless otherwise noted.

PARAMETER		TEST CONDITIONS	MIN	TYP	MAX	UNIT
<b>DIGITAL INPUTS</b>						
$V_{IH}$	Input high voltage		2			V
$V_{IL}$	Input low voltage				0.8	V
$V_{HYS}$	Hysteresis voltage	$V_+ = 3.3\text{ V}$		0.23		V
		$V_+ = 5\text{ V}$		0.33		V
$I_{IH}$	Input high current	$V_{IH} = V_+$ , all pins except $\overline{\text{BTI}}$	-1	-0.005		$\mu\text{A}$
		$V_{IH} = V_+$ , $\overline{\text{BTI}}$ pin	-10	-1		$\mu\text{A}$
$I_{IL}$	Input low current	$V_{IL} = 0\text{ V}$ , all pins except $\overline{\text{BTI}}$		0.005	1	$\mu\text{A}$
		$V_{IL} = 0\text{ V}$ , $V_+ = 5.5\text{ V}$ , $\overline{\text{BTI}}$ pin			2	mA
$C_{IN}$	Input capacitance			20		pF
<b>ANALOG INPUTS</b>						
$V_{IN}$	Input voltage range	Default	0		2.56	V
		Programmable	0		$V_+$	V
$I_{L-ON}$	Input leakage current (on)			$\pm 0.005$		$\mu\text{A}$
$I_{L-OFF}$	Input leakage current (off)			$\pm 0.005$		$\mu\text{A}$
$R_{IN}$	Input resistance			2	10	k $\Omega$
<b>DIGITAL OUTPUTS (A0/NTEST_OUT, INT)</b>						
$V_{OH}$	Output high voltage	$I_{OUT} = 3\text{ mA}/5\text{ mA}$ , $V_+ = 3\text{ V}/4.5\text{ V}$	2.4			V
$V_{OL}$	Output low voltage	$I_{OUT} = 3\text{ mA}/5\text{ mA}$ , $V_+ = 3\text{ V}/4.5\text{ V}$			0.4	V
<b>DIGITAL OPEN-DRAIN OUTPUTS (<math>\overline{\text{GPO}}</math>, <math>\overline{\text{RST\_OUT/OS}}</math>, <math>\overline{\text{GPI/CI}}</math>, <math>\overline{\text{SDA}}</math>)</b>						
$V_{OL}$	Output low voltage	$I_{OUT} = 3\text{ mA}/5\text{ mA}$ , $V_+ = 3\text{ V}/4.5\text{ V}$ , all pins except $\overline{\text{SDA}}$			0.4	V
		$I_{OUT} = 4\text{ mA}$ , $V_+ = 3\text{ V}$ , $\overline{\text{SDA}}$ pin			0.4	V
$I_{OH}$	Output high current	$V_{OUT} = V_+$		0.005	1	$\mu\text{A}$
$t_w$	Pulse duration	$\overline{\text{RST\_OUT/OS}}$ , $\overline{\text{GPI/CI}}$	10	22.5		ms
<b>SMBus</b>						
	SMBus timeout <sup>(1)</sup>			28	35	ms
<b>TEMPERATURE ERROR</b>						
$T_E$	Temperature error	$T_A = -40^{\circ}\text{C}$ to $+125^{\circ}\text{C}$			$\pm 3$	$^{\circ}\text{C}$
		$T_A = -25^{\circ}\text{C}$ to $+100^{\circ}\text{C}$			$\pm 2$	$^{\circ}\text{C}$
$T_R$	Temperature resolution		0.0625			$^{\circ}\text{C}$
<b>ANALOG-TO-DIGITAL CONVERTER</b>						
$V_R$	Resolution	$V_{IN} = 2.56\text{ V}$		2.5		mV
		$V_{IN} = V_+$		6		mV
DNL	Differential linearity		-1		1	LSB <sup>(2)</sup>
$\text{ADC}_{ERR}$	Total unadjusted error <sup>(3)</sup>		-1%		1%	
PSRR	Power supply rejection ratio			$\pm 0.0008\%$		
$t_C$ <sup>(4)</sup>	Total conversion time		662	728	810	ms

(1) The SMBus timeout in the AMC80 resets the interface anytime SCL or SDA is low for over 28 ms.

(2) LSB means least significant bit.

(3) Total unadjusted error contains offset, gain, and linearity errors of the ADC.

(4) Total conversion time contains the temperature conversion, the seven analog input voltage conversions, and the two tachometer readings.

**Electrical Characteristics (continued)**

 At  $T_A$   $-40^{\circ}\text{C}$  to  $+125^{\circ}\text{C}$  and  $V_+ = 3\text{ V}$  to  $5.5\text{ V}$ , unless otherwise noted.

PARAMETER		TEST CONDITIONS	MIN	TYP	MAX	UNIT
<b>FAN RPM-TO-DIGITAL CONVERTER</b>						
FAN <sub>ERR</sub>	Fan RPM error		-10%		10%	
f <sub>CLK</sub>	Internal clock frequency		20.2	22.5	24.8	kHz
FAN <sub>RPM</sub>	FAN1 and FAN2 nominal input RPM	Divisor = 1, fan count = 153		8800		RPM
		Divisor = 2, fan count = 153		4400		
		Divisor = 3, fan count = 153		2200		
		Divisor = 4, fan count = 153		1100		
FSC	Full-scale count				255	Counts
<b>POWER SUPPLY</b>						
V+	Specified voltage range		3		5.5	V
I <sub>QA</sub>	Quiescent current, average	V+ = 5.5 V			100	μA
		V+ = 3.8 V			25	
I <sub>QSD</sub>	Quiescent current, shutdown mode	V+ = 5.5 V			100	μA
		V+ = 3.8 V			25	
<b>TEMPERATURE</b>						
T <sub>A</sub>	Specified range		-40		125	°C

## 6.6 Timing Requirements

At  $T_A$   $-40^{\circ}\text{C}$  to  $+125^{\circ}\text{C}$  and  $V_S = 3\text{V}$  to  $5.5\text{V}$ , unless otherwise noted.

		FAST MODE <sup>(1)</sup>		HIGH-SPEED MODE <sup>(1)</sup>		UNIT
		MIN	MAX	MIN	MAX	
$f_{(SCL)}$	SCL operating frequency	10	400	10	3400	kHz
$t_{(BUF)}$	Bus free time between STOP and START conditions	600		160		ns
$t_{(HDSTA)}$	Hold time after repeated START condition. After this period, the first clock is generated.	600		160		ns
$t_{(SUSTA)}$	Repeated START condition setup time	600		160		ns
$t_{(SUSTO)}$	STOP condition setup time	600		160		ns
$t_{(HDDAT)}$	Data hold time	0 <sup>(2)</sup>		0 <sup>(3)</sup>		ns
$t_{(SUDAT)}$	Data setup time	100		10		ns
$t_{(LOW)}$	Clock low period	1300		160		ns
$t_{(HIGH)}$	Clock high period	600		60		ns
$t_R$	Clock/Data input rise time		300		160	ns
$t_F$	Clock/Data input fall time		300		160	ns

- (1) Values based on a statistical analysis of a one-time sample of devices. Minimum and maximum values are not specified and not production tested.
- (2) For cases when the fall time of SCL is less than 20 ns and/or the rise time or fall time of SDA is less than 20 ns, the hold time should be greater than 20 ns.
- (3) For cases when the fall time of SCL is less than 10 ns and/or the rise or fall time of SDA is less than 10 ns, the hold time should be greater than 10 ns.

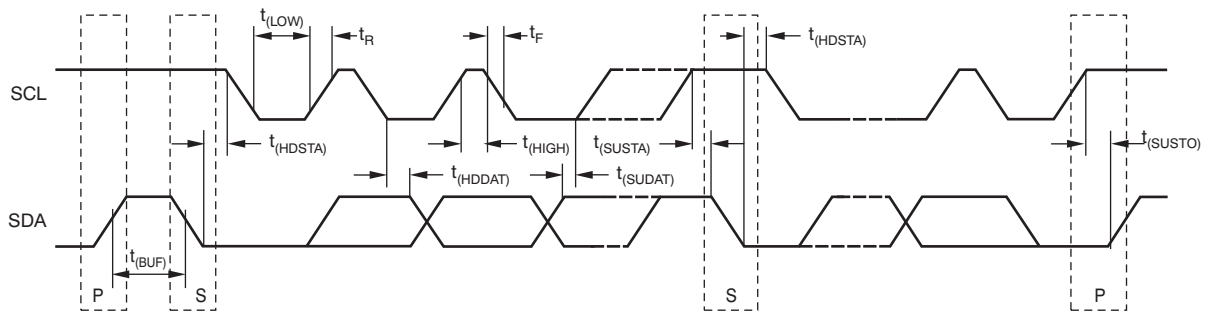
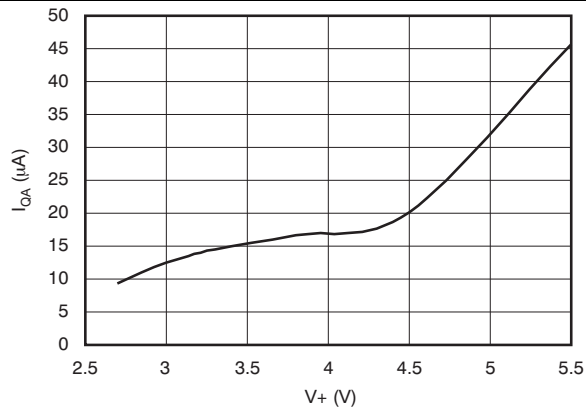

Figure 1. Serial Bus Interface Timing



## 6.7 Typical Characteristics

At  $T_A = +25^\circ\text{C}$  and  $V_+ = 3\text{ V}$  to  $5.5\text{ V}$ , unless otherwise noted.



**Figure 2. Average Quiescent Current vs Supply Voltage**

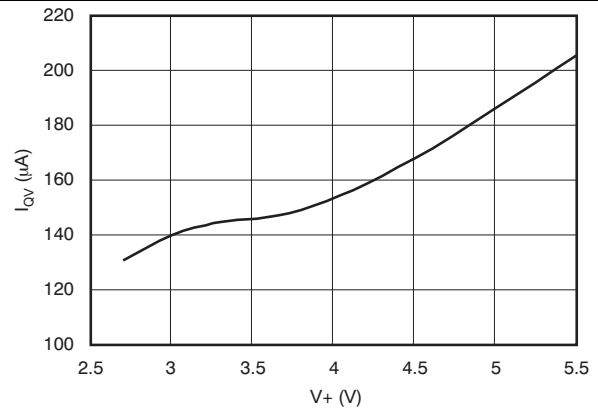

**Figure 3. Quiescent Current During Voltage Conversion vs Supply Voltage**

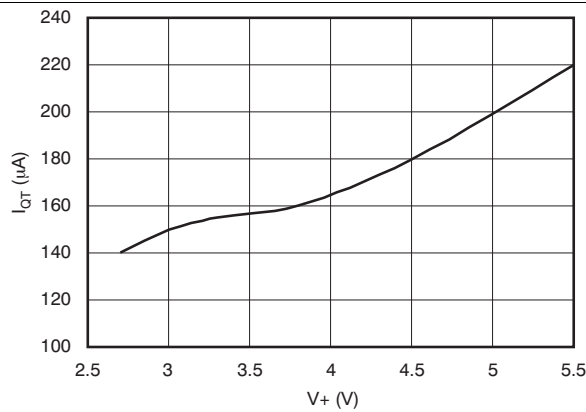

**Figure 4. Quiescent Current During Temperature Conversion vs Supply Voltage**

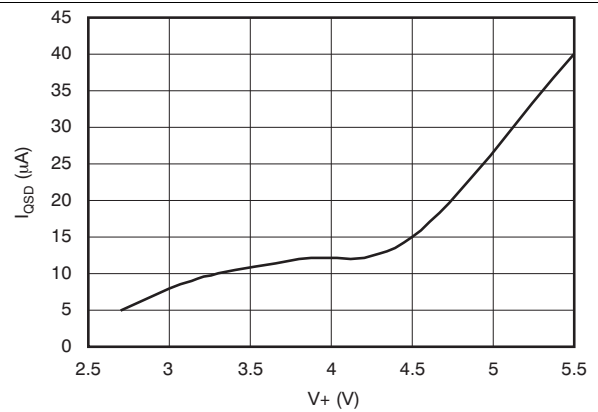

**Figure 5. Quiescent Current During Shutdown vs Supply Voltage**

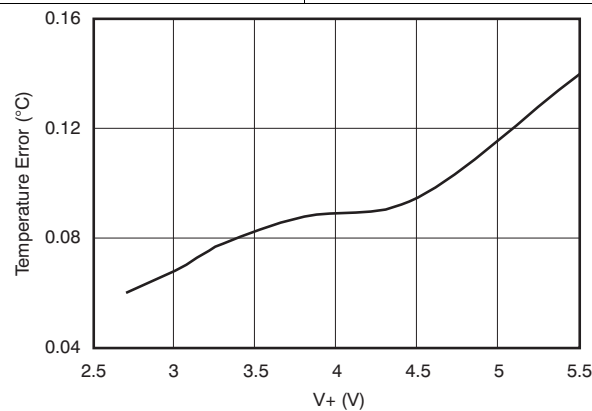

**Figure 6. Temperature Error vs Supply Voltage**

## 7 Detailed Description

### 7.1 Overview

The AMC80 provides seven analog inputs, a temperature sensor, a delta-sigma analog-to-digital converter (ADC), and a variety of inputs and outputs on a single chip. A two-wire SMBus interface is also provided. The AMC80 can continuously perform power-supply, temperature, and fan monitoring for a variety of applications. The AMC80 is fully pin- and software-compatible with the LM96080 and LM80.

### 7.2 Functional Block Diagram

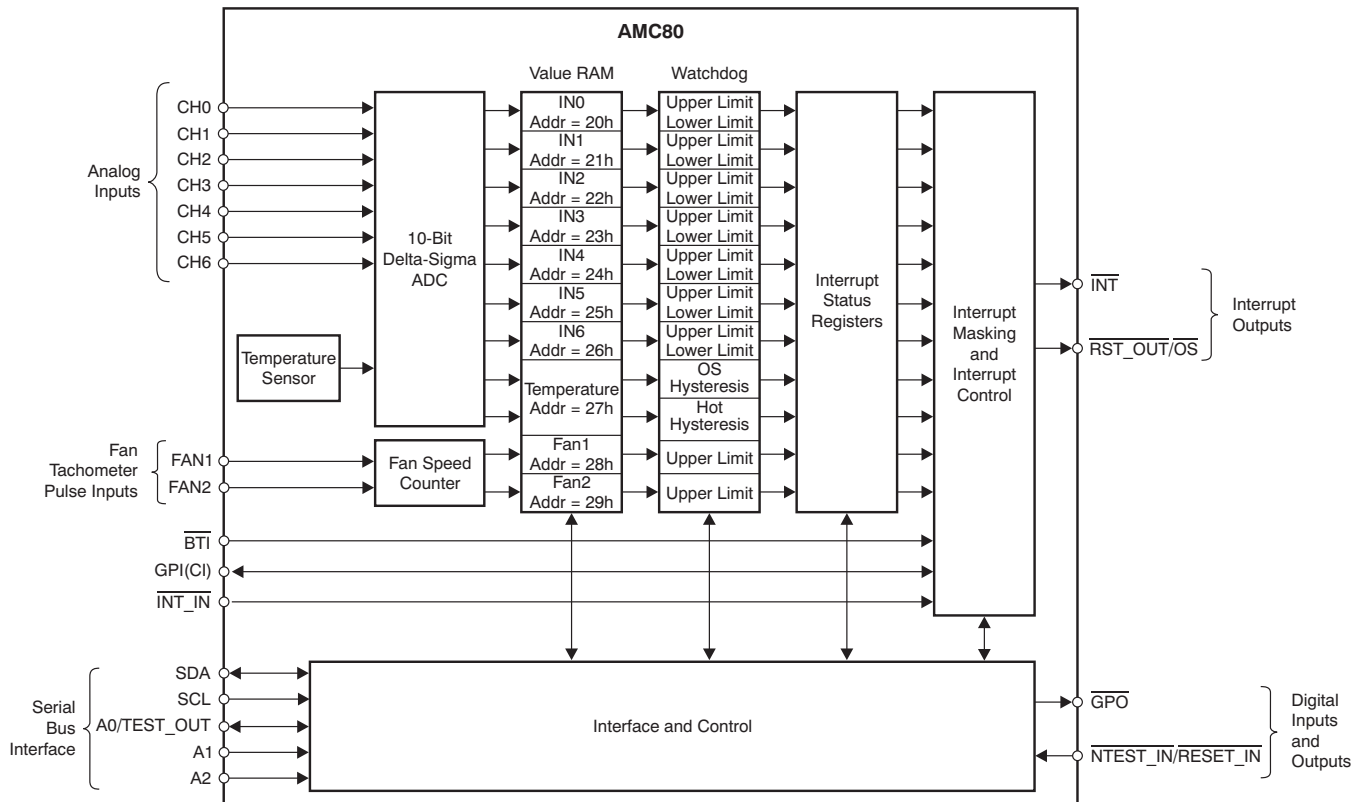

### 7.3 Feature Description

#### 7.3.1 Block Level Description

The AMC80 continuously converts analog inputs to 10-bit resolution using a 2.5-mV least significant bit (LSB) with a default input range of 0 V to 2.56 V, or a 6-mV LSB with a programmable input range of 0 V to V+. The analog inputs (CH0 to CH6) are intended for connection to the several power supplies present in any typical system. Temperature can be converted to a 9-bit or 12-bit resolution with either 0.5°C or 0.0625°C LSB, respectively. The FAN1 and FAN2 inputs can be programmed to accept either a fan failure indicator or tachometer signals. Fan failure signals can be programmed to be either active high or active low. Fan inputs measure the period of tachometer pulses from the fans, providing a higher count for lower fan speeds. The fan inputs are digital inputs with transition levels according to the Digital Inputs section of the [Electrical Characteristics](#) table. Full-scale fan counts are 255 (8-bit counter), which represent a stopped or very slow fan. Nominal speeds, based on a count of 153, are programmable from 1100 RPM to 8800 RPM. Signal conditioning circuitry is included to accommodate slow rise and fall times.

The AMC80 provides a number of internal registers:

- **Configuration Register:** Provides control and configuration.
- **Interrupt Status Registers:** Two registers that provide the status of each interrupt alarm.
- **Interrupt Mask Registers:** Allows masking of individual interrupt sources, as well as separate masking for

## Feature Description (continued)

both hardware interrupt outputs.

- **Fan Divisor/RST\_OUT/OS Register:** Bits 0 to 5 of this register contain the divisor bits for the FAN1 and FAN2 inputs. Bits 6 and 7 control the function of the RST\_OUT/OS output.
- **OS Configuration/Temperature Resolution Register:** The configuration of the overtemperature shutdown (OS) is controlled by the lower three bits of this register. Bit 3 enables 12-bit temperature conversions. In 12-bit mode, bits 4 to 7 represent the four LSBs of the temperature measurement. In 9-bit mode, bit 4 represents the LSB of the temperature measurement.
- **Conversion Rate Register:** Sets the time interval of the continuous monitoring cycle to either fixed or programmable (see the Conversion Rate Count Register for setting the programmable time interval).
- **Voltage/Temperature Channel Disable Register:** Allows voltage inputs and the local temperature conversion to be disabled.
- **Input Mode Register:** Allows voltage inputs to be configured as single-ended or as a differential pair with normal or reverse polarity.
- **ADC Control Register:** Bits 0 to 2 set the programmable conversion rate for the 10-bit ADC. Bits 3 to 5 allow for programmable input full-scale voltage.
- **Conversion Rate Count Register:** Selects the adjustable time interval when the conversion rate of the continuous monitoring cycle is set to programmable.
- **Value RAM:** The monitoring results (for temperature, voltages, fan counts, and Fan Divisor/RST\_OUT/OS Register limits) are all contained in the Value RAM. The Value RAM consists of 32 bytes. The first 10 bytes are all of the results, the next 20 bytes are the interrupt alarm limits, and the last two bytes are at the upper locations for manufacturer ID and die revision ID.

The AMC80 SMBus is compatible with both fast mode (400 kHz) and high-speed mode (3.4 MHz) two-wire interface modes of operation. The AMC80 supports a timeout reset function on SDA and SCL that prevents two-wire bus lockup, and includes an analog filter on the two-wire digital control lines that improves noise immunity. Three address pins (A0 to A2), allow up to eight devices on a single bus. When enabled, the AMC80 starts by cycling through each measurement in sequence, and continuously loops through the sequence based on the Conversion Rate Register (address 07h) setting. Each measured value is compared to values stored in the Value RAM Registers (addresses 2Ah to 3Dh). When the measured value exceeds the programmed limit, the AMC80 sets a corresponding interrupt in the Interrupt Status Registers (addresses 01h and 02h). Two output interrupt lines ( $\overline{\text{INT}}$  and  $\overline{\text{RST\_OUT/OS}}$ ) are available.  $\overline{\text{INT}}$  is fully programmable with the ability to mask each interrupt source and each output. The Fan Divisor/RST\_OUT/OS Register (address 05h) has control bits that enable or disable the hardware interrupts. Additional digital inputs are provided for daisy-chaining the interrupt output pin,  $\overline{\text{INT}}$ . This configuration is achieved by connecting multiple external temperature sensors (for example, the [TMP75](#)) to the board temperature interrupt (BTI) input and/or the GPI/CI input. The chassis intrusion (CI) input is designed to accept an active high signal from an external circuit that latches (for example, when the chassis from a server rack is removed).

## Feature Description (continued)

### 7.3.2 Temperature Measurement

The AMC80  $\Delta V_{BE}$ -type temperature sensor, is a  $\Delta\Sigma$  ADC that performs 9-bit or 12-bit two's complement temperature conversions. An 8-bit comparator that compares the readings to the user-programmable hot and overtemperature setpoints, and hysteresis values is also incorporated into the AMC80.

Temperature data can be read from the Temperature Reading Register (address 27h). Temperature limits can be read from and written to the Hot Temperature ( $T_{HOT}$ ), Hot Temperature Hysteresis ( $T_{HOT\_HYST}$ ),  $\overline{OS}$  Temperature ( $T_{OS}$ ), and  $\overline{OS}$  Temperature Hysteresis ( $T_{OS\_HYST}$ ) Limit Registers (addresses 38h to 3Bh). Each limit is represented in 12-bit, 9-bit, or 8-bit resolution, as shown in [Table 1](#).

**Table 1. Temperature Lookup**

TEMPERATURE	12-BIT DIGITAL OUTPUT (HEX) LSB = 0.0625°C	9-BIT DIGITAL OUTPUT (HEX) LSB = 0.5°C	8-BIT DIGITAL OUTPUT (HEX) LSB = 1°C
+125°C	07D	0FA	7D
+25°C	019	032	19
+1°C	010	003	01
0.0625°C	001	—	—
0°C	000	000	00
-0.0625°C	FFF	—	—
-1°C	FF0	1FF	FF
-25°C	E70	1CE	E7
-55°C	C90	192	C9

When using a single-byte read, the eight MSBs of the temperature reading can be found in the Value RAM Register (address 27h). The remainder of the temperature reading can be found in the  $\overline{OS}$  Configuration/Temperature Resolution Register (address 06h), bits 4 to 7. In 9-bit format, bit 7 is the only valid bit. In addition, all nine or 12 bits can be read using a double-byte read at register address 27h.

There are four Value RAM Register limits for the temperature reading that affect the  $\overline{INT}$  and  $\overline{OS}$  outputs of the AMC80. These are the  $T_{HOT}$ ,  $T_{HOT\_HYST}$ ,  $T_{OS}$ ,  $T_{OS\_HYST}$  Limit Registers (addresses 38h to 3Bh); see [Table 15](#). There are three interrupt modes of operation: Default Interrupt, One-Time Interrupt, and Comparator. The  $\overline{OS}$  output of the AMC80 can be programmed for One-Time Interrupt mode and Comparator mode.  $\overline{INT}$  can be programmed for Default Interrupt mode and One-Time Interrupt mode. These modes are explained in the following subsections.

#### 7.3.2.1 Default Interrupt Mode

In Default Interrupt mode, exceeding  $T_{HOT}$  causes an interrupt that remains active indefinitely until reset by reading Interrupt Status Register 1 (address 01h) or cleared by the INT\_Clear bit in the Configuration Register (address 00h, bit 3). When an interrupt event has occurred by exceeding  $T_{HOT}$ , and is then reset, another interrupt occurs again when the next temperature conversion has completed. The interrupts continue to occur in this manner until the temperature falls below  $T_{HOT\_HYST}$ , at which time the interrupt output automatically clears.

#### 7.3.2.2 One-Time Interrupt Mode

In One-Time Interrupt mode, exceeding  $T_{HOT}$  causes an interrupt that remains active indefinitely until reset by reading Interrupt Status Register 1 or cleared by the INT\_Clear bit in the Configuration Register. When an interrupt event has occurred by exceeding  $T_{HOT}$ , and is then reset, an interrupt does not occur again until the temperature falls below  $T_{HOT\_HYST}$ .

#### 7.3.2.3 Comparator Mode

In Comparator mode, exceeding  $T_{OS}$  causes the  $\overline{OS}$  output to go low (default) and remain low until the temperature falls below  $T_{OS\_HYST}$ . When the temperature falls below  $T_{OS\_HYST}$ ,  $\overline{OS}$  goes high.

### 7.3.3 Interrupt Structure

Figure 7 depicts the interrupt structure of the AMC80.

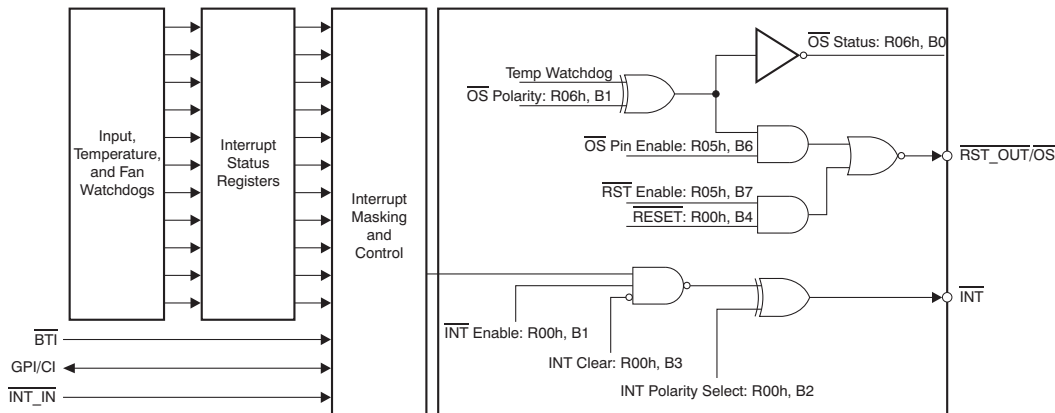

**Figure 7. Interrupt Structure**

External interrupt inputs can come from the following sources:

- **Board Temperature Interrupt ( $\overline{\text{BTI}}$ )** - This pin is an active low interrupt recommended to come from the overtemperature shutdown (OS) output of TMP75 temperature sensors. The TMP75 OS output activates when its temperature exceeds a programmed threshold. If the temperature of any TMP75 exceeds its programmed limit,  $\overline{\text{BTI}}$  is driven low. This action generates an interrupt through bit 1 of Interrupt Status Register 2 (address 02h) that notifies the host of a possible overtemperature condition. To disable this feature, set bit 1 of Interrupt Mask Register 2 (address 04h) to high. This pin also provides an internal, 10-k $\Omega$  pull-up resistor.
- **GPI/CI** - This pin is an active high interrupt from any type of device that detects and captures chassis intrusion violations. This action could be accomplished mechanically, optically, or electrically; circuitry external to the AMC80 is expected to latch the event. Read this interrupt using bit 4 of Interrupt Status Register 2 (address 02h), and disable it using bit 4 of Interrupt Mask Register 2 (address 04h). The design of the AMC80 allows this input to go high even with no power applied, and no clamping or other interference with the line occurs. This line can also be pulled low by the AMC80 for at least 10ms to reset a typical chassis-intrusion circuit. Accomplish this reset by setting bit 5 of the Configuration Register (address 00h) to high; this bit is self-clearing.
- **$\overline{\text{INT\_IN}}$**  - This pin is an active low interrupt that provides a way to connect an  $\overline{\text{INT}}$  from other devices through the AMC80 to the processor. If this pin is pulled low, then bit 7 of Interrupt Status Register 1 (address 01h) goes high, indicating this interrupt detection. Setting bit 1 of the Configuration Register (address 00h) also allows the INT pin to go low when  $\overline{\text{INT\_IN}}$  goes low. To disable this feature, set bit 7 of Interrupt Mask Register 1 (address 03h) to high.

Device interrupt outputs can come from the following sources:

- **$\overline{\text{INT}}$**  - This pin becomes active whenever  $\overline{\text{INT\_IN}}$ ,  $\overline{\text{BTI}}$ , or GPI/CI interrupts.  $\overline{\text{INT}}$  is enabled when bit 1 of the Configuration Register (address 00h) is set high. Bits 2 and 3 of the Configuration Register are also used to set the polarity and state of the  $\overline{\text{INT}}$  interrupt line.
- **$\overline{\text{OS}}$**  - In the Fan Divisor/ $\overline{\text{RST\_OUT/OS}}$  Register (address 05h), bit 6 ( $\overline{\text{OS}}$  Pin Enable), must be set high and bit 7 ( $\overline{\text{RST}}$  Enable) must be set to low in order to enable the  $\overline{\text{OS}}$  function on the  $\overline{\text{RST\_OUT/OS}}$  pin. The  $\overline{\text{OS}}$  pin has two modes of operation: One-Time Interrupt and Comparator. One-Time Interrupt mode is selected by taking bit 2 of the OS Configuration/Temperature Resolution Register (address 06h) high. If bit 2 is taken low, then Comparator mode is selected. Unlike the OS pin, the OS bit in Interrupt Status Register 2 (address 02h, bit 5) functions in Default Interrupt and One-Time Interrupt modes. The OS bit can be masked to the INT pin by taking bit 5 in Interrupt Mask Register 2 (address 04h) low.

Reading the Interrupt Status Registers (addresses 01h to 02h) outputs the contents and then resets the registers and the  $\overline{\text{INT}}$  pin. The  $\overline{\text{INT}}$  pin is also cleared by the INT\_Clear bit (address 00h, bit 3) without affecting the contents of the Interrupt Status Registers. When this bit is high, the AMC80 monitoring loop is inactive; monitoring resumes when this bit is low.

## 7.4 Programming

### 7.4.1 Interface and Control

The SMBus control lines in the AMC80 include SDA, SCL, and the A0 to A2 address pins, which allow up to eight AMC80 devices to be on the same bus. The AMC80 can only operate as a slave device. The SCL line controls only the serial interface; all other clock-related functions within the AMC80 (such as the ADC and fan counters) operate with a separate asynchronous internal clock. The default power-on SMBus address for the AMC80 is '0101'(A2)(A1)(A0) binary, where (A2)(A1)(A0) is the SMBus address.

When using the SMBus interface, a write command always consists of the AMC80 SMBus interface address byte, followed by the internal address register byte, and then the data byte (see [Figure 8](#)).

See [Figure 9](#) for the read operation timing. There are two cases for a read operation:

1. If the contents of the Internal Address Register are known, simply read the AMC80 with the SMBus interface address byte, followed by the data byte read from the AMC80.
2. If the internal Address Register contents are unknown, write to the AMC80 with the SMBus interface address byte, followed by the internal address register byte. Then restart the serial communication with a read that consist of the SMBus interface address byte, followed by the data byte read from the AMC80.

**Table 2. Register Overview**

REGISTER	INTERNAL ADDRESS (HEX)	POWER-ON VALUE (HEX)	NOTES
Configuration Register	00	08	
Interrupt Status Register 1	01	xx	Indeterminate
Interrupt Status Register 2	02	xx	Indeterminate
Interrupt Mask Register 1	03	00	
Interrupt Mask Register 2	04	00	
Fan Divisor/ $\overline{\text{RST\_OUT}}$ / $\overline{\text{OS}}$ Register	05	14	FAN1 and FAN2 divisor = 2 (count of 153 = 4400 RPM)
$\overline{\text{OS}}$ Configuration/Temperature Resolution Register	06	x1	Four MSBs are indeterminate
Conversion Rate Register	07	40	
Voltage/Temperature Channel Disable Register	08	00	Allows voltage monitoring inputs to be disabled
Input Mode Register	09	00	
ADC Control Register	0A	02	
Conversion Rate Count Register	0B	40	
Value RAM Register	20 to 29	xx	Indeterminate
Value RAM Register	2A to 3D	xx	Indeterminate
Value RAM Register	3E	80	
Value RAM Register	3F	09	

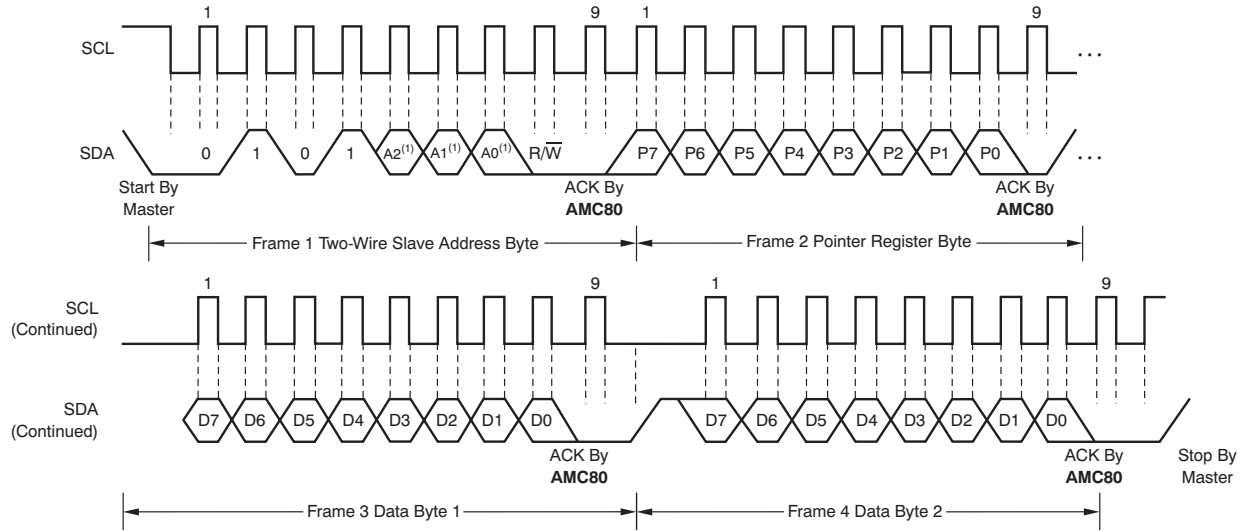

(1) The values of A0, A1, and A2 are determined by the A0, A1, and A2 pins, respectively.

**Figure 8. Two-Wire Timing for Write Word Format**

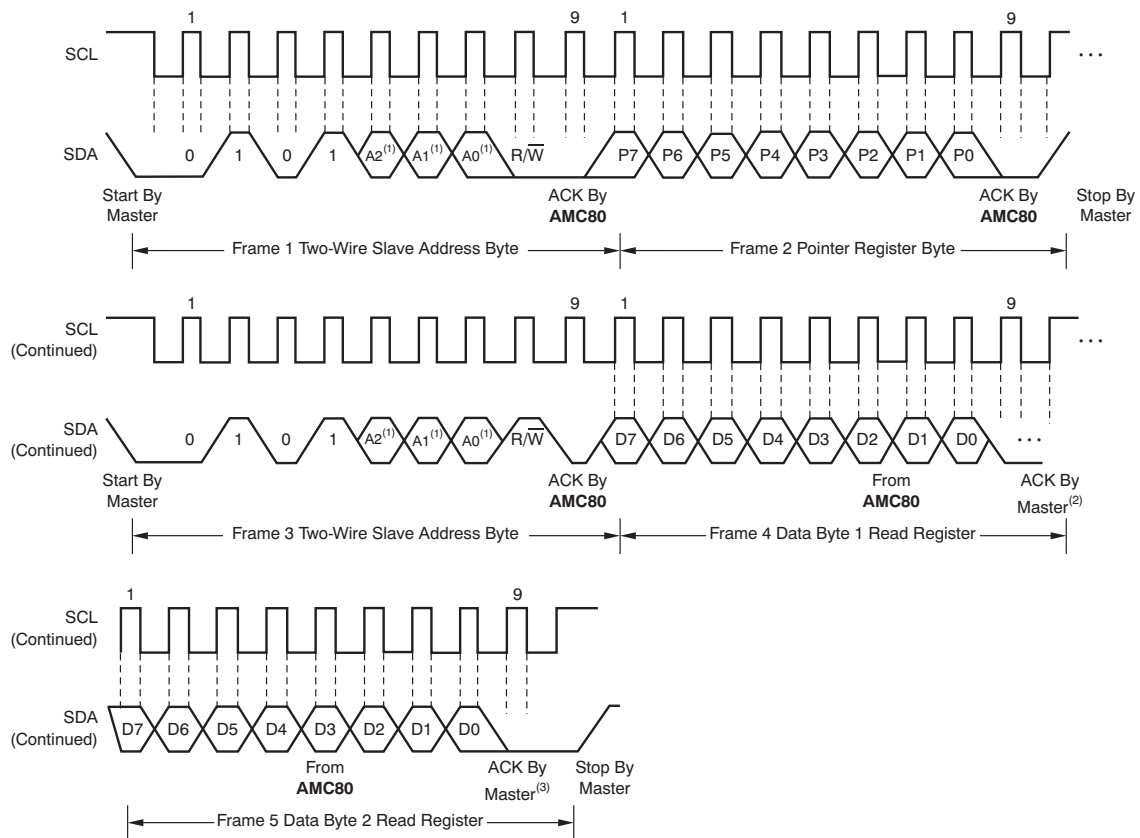

- (1) The values of A0, A1, and A2 are determined by the A0, A1, and A2 pins, respectively.
- (2) Master should leave SDA high to terminate a single-byte read operation.
- (3) Master should leave SDA high to terminate a two-byte read operation.

**Figure 9. Two-Wire Timing for Read Word Format**

## 7.5 Register Map

### 7.5.1 Configuration Register

**Table 3. Configuration Register (Address = 00h, Default = 08h)**

BIT	NAME	TYPE	DESCRIPTION
0	Start	R/W	'1' enables startup of monitoring activity; '0' puts device in shutdown mode.
1	$\overline{\text{INT}}$ Enable	R/W	'1' enables the $\overline{\text{INT}}$ output.
2	$\overline{\text{INT}}$ Polarity Select	R/W	'1' selects active-high, open-source output; '0' selects active-low, open-drain output.
3	INT_Clear	R/W	'1' disables the $\overline{\text{INT}}$ output without affecting the contents of the Interrupt Status Registers. The device stops monitoring and resumes on a '0'.
4	$\overline{\text{RESET}}$	R/W	'1' outputs an active-low reset signal at $\overline{\text{RST\_OUT}}$ , if bit 7 and bit 6 in the Fan Divisor/ Register (address 05h) are set to '1' and '0', respectively. This bit is cleared when the pulse becomes inactive.
5	Chassis Clear	R/W	'1' clears the GPI/CI pin. This bit clears itself after 10ms.
6	$\overline{\text{GPO}}$	R/W	'1' drives the $\overline{\text{GPO}}$ pin low.
7	INITIALIZATION	R/W	'1' restores power-on-default values to the registers. This bit is self-clearing

### 7.5.2 Interrupt Status Registers

**Table 4. Interrupt Status Register 1 (Address = 01h, Default = xxh; see Table 2)**

BIT	NAME	TYPE	DESCRIPTION
0	CH0	Read	'1' indicates a high or low limit has been exceeded.
1	CH1	Read	'1' indicates a high or low limit has been exceeded.
2	CH2	Read	'1' indicates a high or low limit has been exceeded.
3	CH3	Read	'1' indicates a high or low limit has been exceeded.
4	CH4	Read	'1' indicates a high or low limit has been exceeded.
5	CH5	Read	'1' indicates a high or low limit has been exceeded.
6	CH6	Read	'1' indicates a high or low limit has been exceeded.
7	$\overline{\text{INT\_IN}}$	Read	'1' indicates that a low signal has been detected on the $\overline{\text{INT\_IN}}$ pin.

**Table 5. Interrupt Status Register 2 (Address = 02h, Default = xxh; see Table 2)**

BIT	NAME	TYPE	DESCRIPTION
0	Hot Temperature	Read	'1' indicates a high or low limit has been exceeded. One-Time Interrupt and Default Interrupt modes are supported and can be set by bit 6 of Interrupt Mask Register 2 (address 04h).
1	$\overline{\text{BTI}}$	Read	'1' indicates that an interrupt has occurred from the $\overline{\text{BTI}}$ input pin.
2	FAN 1	Read	'1' indicates that a fan count limit has been exceeded.
3	FAN 2	Read	'1' indicates that a fan count limit has been exceeded.
4	GPI/CI	Read	'1' indicates that GPI/CI has gone high.
5	$\overline{\text{OS}}$	Read	'1' indicates a high or low temperature limit has been exceeded. One-Time Interrupt and Default Interrupt modes are supported and can be set by bit 7 of Interrupt Mask Register 2 (address 04h).
6	Reserved	Read	This bit is reserved.
7	Reserved	Read	This bit is reserved.



### 7.5.3 Interrupt Mask Registers

**Table 6. Interrupt Mask Register 1 (Address = 03h, Default = 00h)**

BIT	NAME	TYPE	DESCRIPTION
0	CH0	R/W	'1' disables the corresponding interrupt status bit in Table 4 to trigger the $\overline{\text{INT}}$ interrupt.
1	CH1	R/W	
2	CH2	R/W	
3	CH3	R/W	
4	CH4	R/W	
5	CH5	R/W	
6	CH6	R/W	
7	$\overline{\text{INT\_IN}}$	R/W	

**Table 7. Interrupt Mask Register 2 (Address = 04h, Default = 00h)**

BIT	NAME	TYPE	DESCRIPTION
0	Hot Temperature	R/W	'1' disables the corresponding interrupt status bit in Table 5 to trigger the $\overline{\text{INT}}$ interrupt.
1	$\overline{\text{BTI}}$	R/W	
2	FAN 1	R/W	
3	FAN 2	R/W	
4	GPI/CI	R/W	
5	$\overline{\text{OS}}$	R/W	
6	$\overline{\text{INT}}$ Interrupt Mode Select	R/W	'0' selects Default Interrupt mode. '1' selects One-Time Interrupt mode.
7	$\overline{\text{OS}}$ Interrupt Mode Select	R/W	'0' selects Comparator mode. '1' selects One-Time Interrupt mode.

### 7.5.4 Fan Divisor/ $\overline{\text{RST\_OUT}}$ / $\overline{\text{OS}}$ Register

**Table 8. Fan Divisor/ $\overline{\text{RST\_OUT}}$ / $\overline{\text{OS}}$  Register (Address = 05h, Default = 14h)**

BIT	NAME	TYPE	DESCRIPTION
0	FAN1 Mode Select	R/W	'1' selects the level-sensitive input mode. '0' selects the fan count mode for the FAN1 input.
1	FAN2 Mode Select	R/W	'1' selects the level-sensitive input mode. '0' selects the fan count mode for the FAN2 input.
2	FAN1 RPM Control 1	R/W	FAN1 speed control: '00' = divide by 1. '01' = divide by 2. '10' = divide by 4. '11' = divide by 8. If level-sensitive input is selected, '01' selects an active-low input and '00' selects an active-high input.
3	FAN1 RPM Control 0	R/W	
4	FAN2 RPM Control 1	R/W	FAN2 speed control: '00' = divide by 1. '01' = divide by 2. '10' = divide by 4. '11' = divide by 8. If level select input is selected, '01' selects an active-low input and '00' selects an active-high input.
5	FAN2 RPM Control 0	R/W	
6	$\overline{\text{OS}}$ Pin Enable	R/W	'1' enables $\overline{\text{OS}}$ mode on the $\overline{\text{RST\_OUT/OS}}$ pin when bit 7 is set to '0'. NOTE: When bits 6 and 7 are both set to '1', the $\overline{\text{RST\_OUT/OS}}$ pin is disabled.
7	$\overline{\text{RST\_OUT}}$ Pin Enable	R/W	'1' enables $\overline{\text{RST\_OUT}}$ mode on the $\overline{\text{RST\_OUT/OS}}$ pin when bit 6 is set to '0'. NOTE: When bits 6 and 7 are both set to '1', the $\overline{\text{RST\_OUT/OS}}$ pin is disabled.

### 7.5.5 $\overline{OS}$ Configuration/Temperature Resolution Register

**Table 9.  $\overline{OS}$  Configuration/Temperature Resolution Register (Address = 06h, Default = x1h; see Table 2)**

BIT	NAME	TYPE	DESCRIPTION
0	OS Status	Read	This bit mirrors the state of the $\overline{RST\_OUT/OS}$ pin when in $\overline{OS}$ mode.
1	OS Polarity	R/W	'1' selects $\overline{OS}$ to be active-high '0' selects $\overline{OS}$ to be active-low.
2	OS Mode Select	R/W	'1' selects One-Time-Interrupt mode; '0' selects Comparator mode.
3	Temperature Resolution Control	R/W	'1' selects 11-bit plus sign resolution temperature conversion; '0' selects the default 8-bit plus sign resolution temperature conversion.
4	Temp3	R/W	The lower four LSBs of the 11-bit plus sign temperature data. For 8-bit plus sign temperature data, bit 7 is the LSB and bits 4 to 6 are undefined.
5	Temp2	R/W	
6	Temp1	R/W	
7	Temp0	R/W	

### 7.5.6 Conversion Rate Register

**Table 10. Conversion Rate Register (Address = 07h, Default = 40h)**

BIT	NAME	TYPE	DESCRIPTION
0	CR1	R/W	Controls conversion rate: '0' = Programmable conversion rate by the following formula: Monitoring delay = (ms) = $1.42 \times (8 \times N + 6)$ where $N$ can be set by bits 7:0 in the Conversion Rate Count Register (address 0Bh). '1' = Continuous conversion.
1	Reserved	R/W	'0' must be written to this bit.
2	Reserved	R/W	'0' must be written to this bit.
3	Reserved	R/W	'0' must be written to this bit.
4	Reserved	R/W	'0' must be written to this bit.
5	Reserved	R/W	'0' must be written to this bit.
6	Reserved	R/W	'0' must be written to this bit.
7	Reserved	R/W	'0' must be written to this bit.

### 7.5.7 Voltage/Temperature Channel Disable Register

**Table 11. Voltage/Temperature Channel Disable Register (Address = 08h, Default = 00h)**

BIT	NAME	TYPE	DESCRIPTION
0	CH0	R/W	'1' disables conversions and suppresses error events; Value RAM Register reads '0' for CH0.
1	CH1	R/W	'1' disables conversions and suppresses error events; Value RAM Register reads '0' for CH1.
2	CH2	R/W	'1' disables conversions and suppresses error events; Value RAM Register reads '0' for CH2.
3	CH3	R/W	'1' disables conversions and suppresses error events; Value RAM Register reads '0' for CH3.
4	CH4	R/W	'1' disables conversions and suppresses error events; Value RAM Register reads '0' for CH4.
5	CH5	R/W	'1' disables conversions and suppresses error events; Value RAM Register reads '0' for CH5.
6	CH6	R/W	'1' disables conversions and suppresses error events; Value RAM Register reads '0' for CH6.
7	Temp	R/W	'1' disables conversions and suppresses error events; Value RAM Register reads '0' for temperature.

### 7.5.8 Input Mode Register

**Table 12. Input Mode Register (Address = 09h, Default = 00h)**

BIT	NAME	TYPE	DESCRIPTION
0	Diff01	R/W	When set to '1', CH0 and CH1 operate as a differential input. When set to '0', CH0 and CH1 operate as 2 single-ended inputs.
1	Pol01	R/W	When bit 0 = '1', CH0 and CH1 differential inputs are setup in normal polarity mode when this bit is set to '1', and in reverse polarity mode when this bit is set to '0'. When bit 0 is set to "0", this bit is ignored.
2	Diff23	R/W	When set to '1', CH2 and CH3 operate as a differential input. When set to '0', CH2 and CH3 operate as 2 single-ended inputs.
3	Pol23	R/W	When bit 0 = '1', CH2 and CH3 differential inputs are setup in normal polarity mode when this bit is set to '1', and in reverse polarity mode when this bit is set to '0'. When bit 0 is set to "0", this bit is ignored.
4	Diff45	R/W	When set to '1', CH4 and CH5 operate as a differential input. When set to '0', CH4 and CH5 operate as 2 single-ended inputs.
5	Pol45	R/W	When bit 0 = '1', CH4 and CH5 differential inputs are setup in normal polarity mode when this bit is set to '1', and in reverse polarity mode when this bit is set to '0'. When bit 0 is set to "0", this bit is ignored.
6	Reserved	R/W	'0' must be written to this bit.
7	Reserved	R/W	'0' must be written to this bit.

### 7.5.9 ADC Control Register

**Table 13. ADC Control Register (Address = 0Ah, Default = 02h)**

BIT	NAME	TYPE	DESCRIPTION
0	DR2	R/W	The 10-bit ADC conversion rate for the analog inputs is set as follows: 000 = 0.512 kHz 001 = 1 kHz 010 = 1.98 kHz 011 = 3.6 kHz 100 = 6.3 kHz 101 = 9.8 kHz 110 = 13.15 kHz 111 = 13.15 kHz
1	DR1	R/W	
2	DR0	R/W	
3	PGA2	R/W	The full-scale analog input range is set as follows: 000 = 2.56 V 001 = $V_{DD}$ 010 = 4.096 V or $V_{DD}$ (whichever is less) 011 = 2.048 V 100 = 1.024 V 101 = 0.512 V 110 = 0.256 V 111 = 0.256 V
4	PGA1	R/W	
5	PGA0	R/W	
6	Reserved	R/W	'0' must be written to this bit.
7	Reserved	R/W	'0' must be written to this bit.

### 7.5.10 Conversion Rate Count Register

**Table 14. Conversion Rate Count Register (Address = 0Bh, Default = 40h)**

BIT	NAME	TYPE	DESCRIPTION
0	CRC7	R/W	When bit 0 of the Conversion Rate Register (address 07h) is set to '0', the monitoring conversion delay can be programmed as follows: 0000000 = 0 0000001 = 1 0000010 = 2 ... .. 1111111 = 255 When bit 0 of the Conversion Rate Register is set to '1', these bits are ignored.
1	CRC6	R/W	
2	CRC5	R/W	
3	CRC4	R/W	
4	CRC3	R/W	
5	CRC2	R/W	
6	CRC1	R/W	
7	CRC0	R/W	

### 7.5.11 Value Ram Register

**Table 15. Value RAM Register (Addresses = 20h to 3Fh)**

ADDRESS (HEX)	DESCRIPTION
20	CH0 reading (10-bit)
21	CH1 reading (10-bit)
22	CH2 reading (10-bit)
23	CH3 reading (10-bit)
24	CH4 reading (10-bit)
25	CH5 reading (10-bit)
26	CH6 reading (10-bit)
27	Temperature reading (9-bit or 12-bit for easy readback)
28	FAN1 reading
29	FAN2 reading
2A	CH0 high limit
2B	CH0 low limit
2C	CH1 high limit
2D	CH1 low limit
2E	CH2 high limit
2F	CH2 low limit
30	CH3 high limit
31	CH3 low limit
32	CH4 high limit
33	CH4 low limit
34	CH5 high limit
35	CH5 low limit
36	CH6 high limit
37	CH6 low limit
38	Hot temperature high limit (T <sub>HOT</sub> )
39	Hot temperature hysteresis low limit (T <sub>HOT_HYST</sub> )
3A	$\overline{OS}$ temperature high limit (T <sub>OS</sub> )
3B	$\overline{OS}$ temperature hysteresis low limit (T <sub>OS_HYST</sub> )
3C	FAN1 fan count limit
3D	FAN2 fan count limit
3E	Manufacturer ID (always defaults to 80h)
3F	Die revision ID (always defaults to 08h)

## 8 Application and Implementation

---

### NOTE

Information in the following applications sections is not part of the TI component specification, and TI does not warrant its accuracy or completeness. TI's customers are responsible for determining suitability of components for their purposes. Customers should validate and test their design implementation to confirm system functionality.

---

### 8.1 Application Information

#### 8.1.1 Device Power-On

The AMC80 undergoes a power-on-reset condition when power is first applied to the device, or when the Configuration Register INITIALIZATION bit (address 00h, bit 7) is set high; this bit automatically clears after being set. The AMC80 can also be forced to a reset condition by taking the NTEST\_IN/RESET\_IN pin low for at least 50 ns.

To start the AMC80 monitoring functions (temperature, analog inputs, and fan speeds), write to the Configuration Register with a '0' to INT\_Clear (bit 3) and a '1' to Start (bit 0). The AMC80 then performs continuous monitoring of all temperature, analog inputs, and fan speeds. The sequence of items that are monitored (except for the temperature reading) corresponds to locations in the Value RAM, respectively:

1. Temperature
2. CH0
3. CH1
4. CH2
5. CH3
6. CH4
7. CH5
8. CH6
9. Fan 1
10. Fan 2

The conversion results are available in the Value RAM (addresses 20h to 29h). Conversions can be read at any time and provide the result of the last conversion. A typical sequence of events after AMC80 power-on consists of these actions:

1. Set alarm limits
2. Set interrupt masks
3. Start the AMC80 monitoring process

## Application Information (continued)

### 8.1.2 Analog Inputs

In the default state, the 10-bit ADC has a 2.5-mV LSB, yielding a 2.56-V full-scale input range. The input range can also be programmed with several values up to the V+ full-scale input range with a 6-mV LSB. These settings are programmed by bits 3 to 5 in the ADC Control Register.

In most applications, the analog inputs are often connected to power supplies. The voltage inputs should be attenuated with external resistors to any desired value within the input range.

#### CAUTION

Care should be taken not to exceed V+ on the device input pins at any time.

In select applications where inputs to be monitored are differential in nature, analog inputs (CH0 to CH5) can be configured as up to three differential pairs (inputs 0-1, 2-3, and 4-5) by setting bits 0, 2, and 4 in the Input Mode Register. If needed, the input pair polarity can be changed by setting bits 1, 3, and 5 in the Input Mode Register.

### 8.1.3 Fan Inputs

Inputs are provided on the AMC80 for signals from fans equipped with tachometer outputs. Signal conditioning in the AMC80 accommodates the slow rise and fall times typical of fan tachometer outputs. The maximum input signal range is 0 V to 5.5 V. In the event that these inputs are supplied from fan outputs that exceed 0 V to 5.5 V, either resistive division or diode clamping must be included to keep inputs within an acceptable range.

The Fan Inputs gate an internal 22.5-kHz oscillator for one period of the Fan signal into an 8-bit counter (maximum count = 255). The default divisor is set to 2 (choices are 1, 2, 4, and 8) providing a nominal count of 153 for a 4400 RPM fan with two pulses per revolution. Typical practice is to consider 70% of normal RPM a fan failure, at which point the count will be 219. The fan count can be determined as shown in [Equation 1](#):

$$\text{Count} = \frac{1.35 \times 10^6}{\text{RPM} \times \text{Divisor}}$$

Where:

RPM = fan speed

Divisor = fan 1 or fan 2 divisor set through the Fan\_Divisor/RST\_OUT/OS Register (address 05h) (1)

FAN1 and FAN2 inputs can also be programmed to be level-sensitive interrupt inputs. Fans that provide only one pulse per revolution require a divisor that is set twice as high as fans that provide two pulses, thus maintaining a nominal fan count of 153. Therefore, using [Equation 1](#), the divisor should be set to 4 for a fan that provides one pulse per revolution with a nominal RPM of 4400.

## 9 Device and Documentation Support

### 9.1 Community Resources

The following links connect to TI community resources. Linked contents are provided "AS IS" by the respective contributors. They do not constitute TI specifications and do not necessarily reflect TI's views; see TI's [Terms of Use](#).

**TI E2E™ Online Community** *TI's Engineer-to-Engineer (E2E) Community*. Created to foster collaboration among engineers. At [e2e.ti.com](http://e2e.ti.com), you can ask questions, share knowledge, explore ideas and help solve problems with fellow engineers.

**Design Support** *TI's Design Support* Quickly find helpful E2E forums along with design support tools and contact information for technical support.

### 9.2 Trademarks

E2E is a trademark of Texas Instruments.  
All other trademarks are the property of their respective owners.

### 9.3 Electrostatic Discharge Caution



This integrated circuit can be damaged by ESD. Texas Instruments recommends that all integrated circuits be handled with appropriate precautions. Failure to observe proper handling and installation procedures can cause damage.

ESD damage can range from subtle performance degradation to complete device failure. Precision integrated circuits may be more susceptible to damage because very small parametric changes could cause the device not to meet its published specifications.

### 9.4 Glossary

[SLYZ022](#) — *TI Glossary*.

This glossary lists and explains terms, acronyms, and definitions.

## 10 Mechanical, Packaging, and Orderable Information

The following pages include mechanical, packaging, and orderable information. This information is the most current data available for the designated devices. This data is subject to change without notice and revision of this document. For browser-based versions of this data sheet, refer to the left-hand navigation.

**PACKAGING INFORMATION**

Orderable part number	Status (1)	Material type (2)	Package   Pins	Package qty   Carrier	RoHS (3)	Lead finish/ Ball material (4)	MSL rating/ Peak reflow (5)	Op temp (°C)	Part marking (6)
<a href="#">AMC80AIPWR</a>	Active	Production	TSSOP (PW)   24	2000   LARGE T&R	Yes	NIPDAU	Level-2-260C-1 YEAR	-40 to 125	AMC80A
AMC80AIPWR.A	Active	Production	TSSOP (PW)   24	2000   LARGE T&R	Yes	NIPDAU	Level-2-260C-1 YEAR	-40 to 125	AMC80A

(1) **Status:** For more details on status, see our [product life cycle](#).

(2) **Material type:** When designated, preproduction parts are prototypes/experimental devices, and are not yet approved or released for full production. Testing and final process, including without limitation quality assurance, reliability performance testing, and/or process qualification, may not yet be complete, and this item is subject to further changes or possible discontinuation. If available for ordering, purchases will be subject to an additional waiver at checkout, and are intended for early internal evaluation purposes only. These items are sold without warranties of any kind.

(3) **RoHS values:** Yes, No, RoHS Exempt. See the [TI RoHS Statement](#) for additional information and value definition.

(4) **Lead finish/Ball material:** Parts may have multiple material finish options. Finish options are separated by a vertical ruled line. Lead finish/Ball material values may wrap to two lines if the finish value exceeds the maximum column width.

(5) **MSL rating/Peak reflow:** The moisture sensitivity level ratings and peak solder (reflow) temperatures. In the event that a part has multiple moisture sensitivity ratings, only the lowest level per JEDEC standards is shown. Refer to the shipping label for the actual reflow temperature that will be used to mount the part to the printed circuit board.

(6) **Part marking:** There may be an additional marking, which relates to the logo, the lot trace code information, or the environmental category of the part.

Multiple part markings will be inside parentheses. Only one part marking contained in parentheses and separated by a "~" will appear on a part. If a line is indented then it is a continuation of the previous line and the two combined represent the entire part marking for that device.

**Important Information and Disclaimer:** The information provided on this page represents TI's knowledge and belief as of the date that it is provided. TI bases its knowledge and belief on information provided by third parties, and makes no representation or warranty as to the accuracy of such information. Efforts are underway to better integrate information from third parties. TI has taken and continues to take reasonable steps to provide representative and accurate information but may not have conducted destructive testing or chemical analysis on incoming materials and chemicals. TI and TI suppliers consider certain information to be proprietary, and thus CAS numbers and other limited information may not be available for release.

In no event shall TI's liability arising out of such information exceed the total purchase price of the TI part(s) at issue in this document sold by TI to Customer on an annual basis.

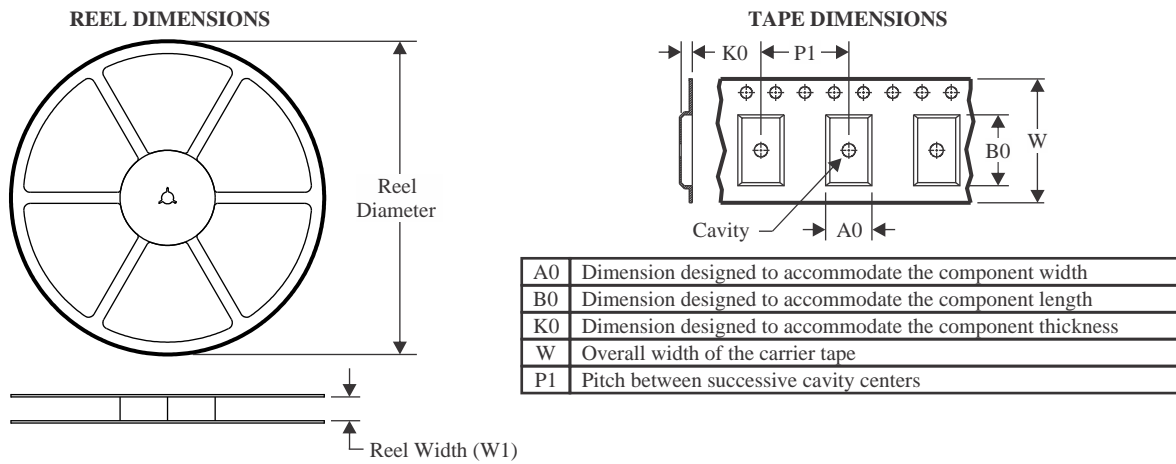

**TAPE AND REEL INFORMATION**

**QUADRANT ASSIGNMENTS FOR PIN 1 ORIENTATION IN TAPE**

\*All dimensions are nominal

Device	Package Type	Package Drawing	Pins	SPQ	Reel Diameter (mm)	Reel Width W1 (mm)	A0 (mm)	B0 (mm)	K0 (mm)	P1 (mm)	W (mm)	Pin1 Quadrant
AMC80AIPWR	TSSOP	PW	24	2000	330.0	16.4	6.95	8.3	1.6	8.0	16.0	Q1

**TAPE AND REEL BOX DIMENSIONS**

\*All dimensions are nominal

Device	Package Type	Package Drawing	Pins	SPQ	Length (mm)	Width (mm)	Height (mm)
AMC80AIPWR	TSSOP	PW	24	2000	350.0	350.0	43.0



# EXAMPLE BOARD LAYOUT

PW0024A

TSSOP - 1.2 mm max height

SMALL OUTLINE PACKAGE

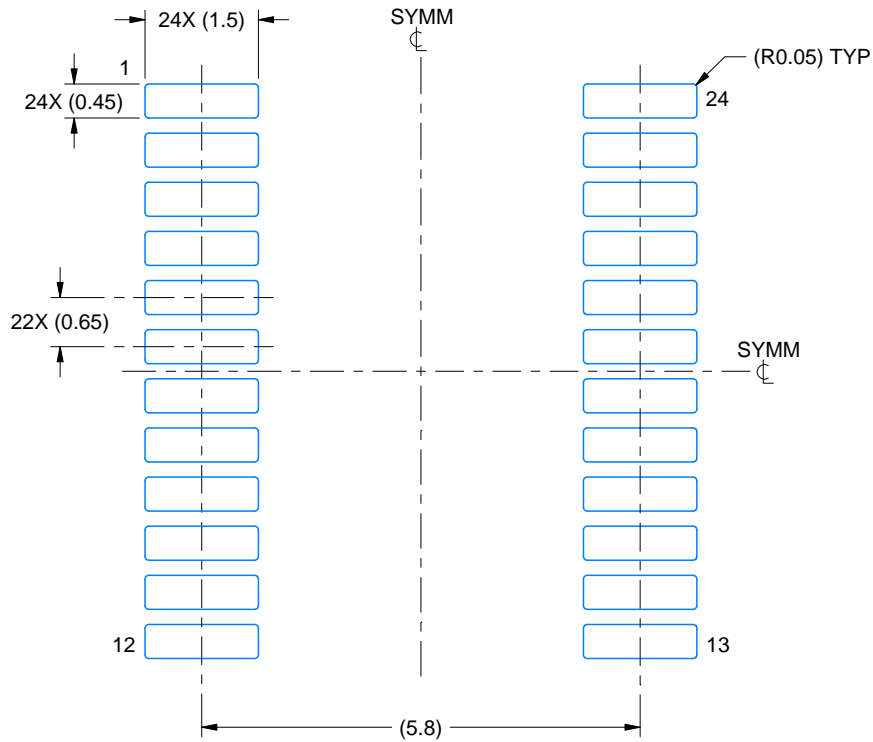

LAND PATTERN EXAMPLE  
EXPOSED METAL SHOWN  
SCALE: 10X

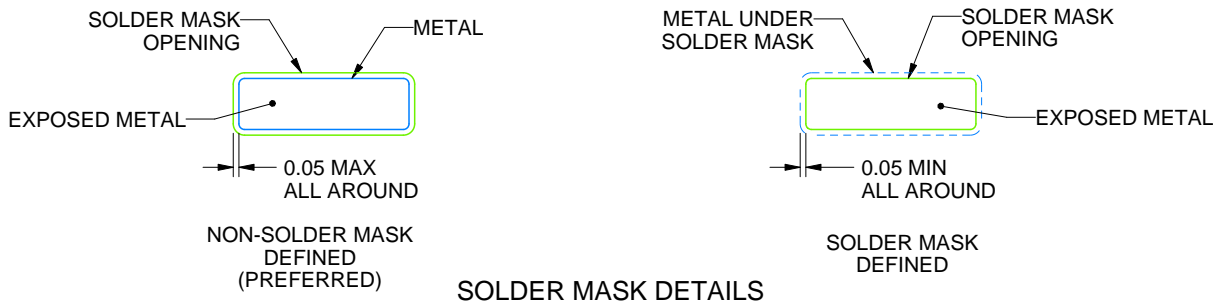

SOLDER MASK DETAILS

4220208/A 02/2017

NOTES: (continued)

- 6. Publication IPC-7351 may have alternate designs.
- 7. Solder mask tolerances between and around signal pads can vary based on board fabrication site.

# EXAMPLE STENCIL DESIGN

PW0024A

TSSOP - 1.2 mm max height

SMALL OUTLINE PACKAGE

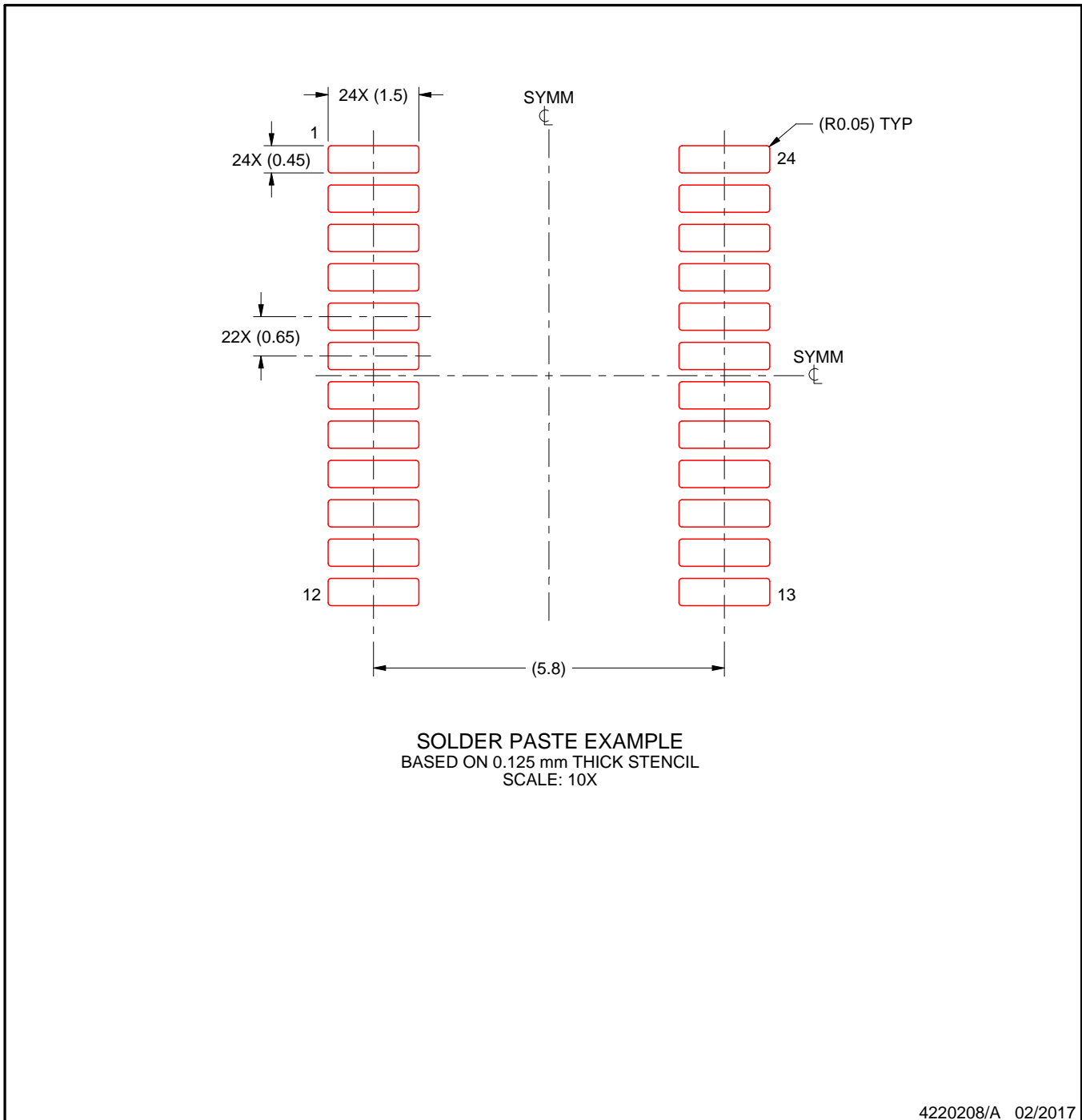

NOTES: (continued)

8. Laser cutting apertures with trapezoidal walls and rounded corners may offer better paste release. IPC-7525 may have alternate design recommendations.
9. Board assembly site may have different recommendations for stencil design.

## IMPORTANT NOTICE AND DISCLAIMER

TI PROVIDES TECHNICAL AND RELIABILITY DATA (INCLUDING DATASHEETS), DESIGN RESOURCES (INCLUDING REFERENCE DESIGNS), APPLICATION OR OTHER DESIGN ADVICE, WEB TOOLS, SAFETY INFORMATION, AND OTHER RESOURCES "AS IS" AND WITH ALL FAULTS, AND DISCLAIMS ALL WARRANTIES, EXPRESS AND IMPLIED, INCLUDING WITHOUT LIMITATION ANY IMPLIED WARRANTIES OF MERCHANTABILITY, FITNESS FOR A PARTICULAR PURPOSE OR NON-INFRINGEMENT OF THIRD PARTY INTELLECTUAL PROPERTY RIGHTS.

These resources are intended for skilled developers designing with TI products. You are solely responsible for (1) selecting the appropriate TI products for your application, (2) designing, validating and testing your application, and (3) ensuring your application meets applicable standards, and any other safety, security, regulatory or other requirements.

These resources are subject to change without notice. TI grants you permission to use these resources only for development of an application that uses the TI products described in the resource. Other reproduction and display of these resources is prohibited. No license is granted to any other TI intellectual property right or to any third party intellectual property right. TI disclaims responsibility for, and you fully indemnify TI and its representatives against any claims, damages, costs, losses, and liabilities arising out of your use of these resources.

TI's products are provided subject to [TI's Terms of Sale](#), [TI's General Quality Guidelines](#), or other applicable terms available either on [ti.com](#) or provided in conjunction with such TI products. TI's provision of these resources does not expand or otherwise alter TI's applicable warranties or warranty disclaimers for TI products. Unless TI explicitly designates a product as custom or customer-specified, TI products are standard, catalog, general purpose devices.

TI objects to and rejects any additional or different terms you may propose.

Copyright © 2026, Texas Instruments Incorporated

Last updated 10/2025