

High Speed CMOS Logic Hex Buffer/Line Driver, Three-State Non-Inverting and Inverting

1 Features

- Buffered inputs
- High current bus driver outputs
- Typical propagation delay $t_{PLH}, t_{PHL} = 8$ ns at $V_{CC} = 5$ V, $C_L = 15$ pF, $T_A = 25^\circ\text{C}$
- Fanout (over temperature range)
 - Standard outputs: 10 LSTTL Loads
 - Bus driver outputs: 15 LSTTL Loads
- Wide operating temperature range: -55°C to 125°C
- Balanced propagation delay and transition times
- Significant power reduction compared to LSTTL Logic ICs
- HC types
 - 2 V to 6 V operation
 - High Noise Immunity: $N_{IL} = 30\%$, $N_{IH} = 30\%$ of V_{CC} at $V_{CC} = 5$ V
- HCT types
 - 4.5 V to 5.5 V operation
 - Direct LSTTL input logic compatibility, $V_{IL} = 0.8$ V (max), $V_{IH} = 2$ V (min)
 - CMOS input compatibility, $I_I \leq 1\mu\text{A}$ at V_{OL}, V_{OH}

Device Information

PART NUMBER	PACKAGE ⁽¹⁾	BODY SIZE (NOM)
CD54HC365	J (CERDIP, 16)	19.56 x 6.92 mm
CD54HC366	J (CERDIP, 16)	19.56 x 6.92 mm
CD54HCT365	J (CERDIP, 16)	19.56 x 6.92 mm
CD74HC365	N (PDIP, 16)	19.30 x 6.35 mm
	D (SOIC, 16)	9.90 x 3.90 mm
	D (SOIC, 16)	9.90 x 3.90 mm
	D (SOIC, 16)	9.90 x 3.90 mm
CD74HC366	N (PDIP, 16)	19.30 x 6.35 mm
	D (SOIC, 16)	9.90 x 3.90 mm
	D (SOIC, 16)	9.90 x 3.90 mm
CD74HCT365	N (PDIP, 16)	19.30 x 6.35 mm
	D (SOIC, 16)	9.90 x 3.90 mm
	D (SOIC, 16)	9.90 x 3.90 mm
	D (SOIC, 16)	9.90 x 3.90 mm

(1) For all available packages, see the orderable addendum at the end of the data sheet.

2 Description

The 'HC365, 'HCT365, and 'HC366 silicon gate CMOS three-state buffers are general purpose high-speed non-inverting and inverting buffers.

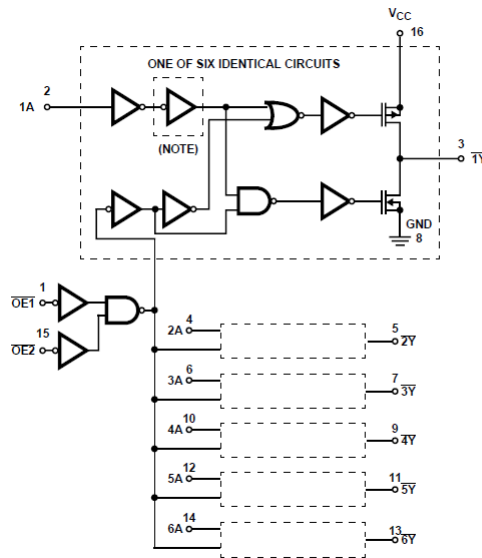

Logic Diagram for the HC/HCT365 and HC366 (Outputs for HC/HCT365 are Complements of Those Shown, i.e., 1Y, 2Y, etc.)

A. Inverter not included in HC/HCT 365.



Table of Contents

1 Features	1	7.2 Functional Block Diagram.....	8
2 Description	1	7.3 Device Functional Modes.....	8
3 Revision History	2	8 Power Supply Recommendations	9
4 Pin Configuration and Functions	3	9 Layout	9
5 Specifications	4	9.1 Layout Guidelines.....	9
5.1 Absolute Maximum Ratings ⁽¹⁾	4	10 Device and Documentation Support	10
5.2 Operating Conditions.....	4	10.1 Receiving Notification of Documentation Updates..	10
5.3 Thermal Information.....	4	10.2 Support Resources.....	10
5.4 Electrical Characteristics.....	5	10.3 Trademarks.....	10
5.5 HCT Input Loading Table.....	6	10.4 Electrostatic Discharge Caution.....	10
5.6 Switching Characteristics.....	6	10.5 Glossary.....	10
6 Parameter Measurement Information	7	11 Mechanical, Packaging, and Orderable Information	10
7 Detailed Description	8		
7.1 Overview.....	8		

3 Revision History

NOTE: Page numbers for previous revisions may differ from page numbers in the current version.

Changes from Revision C (October 2003) to Revision D (July 2022)	Page
• Updated the numbering, formatting, tables, figures, and cross-references throughout the document to reflect modern data sheet standards.....	1

4 Pin Configuration and Functions

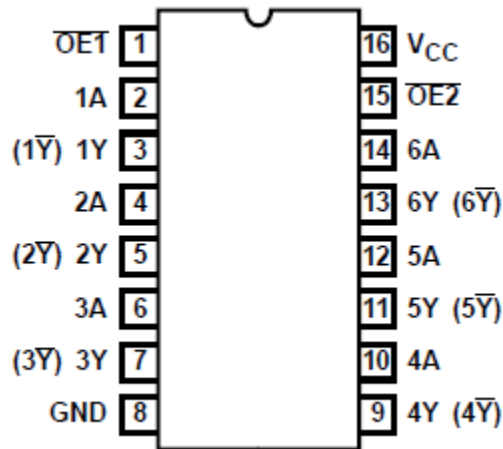

Figure 4-1. CD54HC365, CD54HCT365, CD54HC366 (CERDIP) CD74HC365, CD74HCT365, CD74HC366 (PDIP, SOIC) Top View

Table 4-1. Pin Functions

NO.	PIN		TYPE ⁽¹⁾	DESCRIPTION
	NAME			
1	$\overline{OE1}$		I	Output Enable 1, Active Low
2	1A		I	1A Input
3	1Y		O	1Y Output
4	2A		I	2A Input
5	2Y		O	2Y Output
6	3A		I	3A Input
7	3Y		O	3Y Output
8	GND		—	Ground Pin
9	4Y		O	4Y Output
10	4A		I	4A Input
11	5Y		O	5Y Output
12	5A		I	5A Input
13	6Y		O	6Y Output
14	6A		I	6A Input
15	$\overline{OE2}$		I	Output Enable 2, Active Low
16	V _{CC}		—	Power Pin

(1) Signal Types: I = Input, O = Output, I/O = Input or Output.

5 Specifications

5.1 Absolute Maximum Ratings⁽¹⁾

			MIN	MAX	UNIT
V _{CC}	DC supply voltage		-0.5	7	V
I _{IK}	DC input diode current	For V _I < -0.5 V or V _I > V _{CC} + 0.5 V		±20	mA
I _{OK}	DC output diode current	For V _O < -0.5 V or V _O > V _{CC} + 0.5 V		±20	mA
I _O	DC drain current, per output	For -0.5 V < V _O < V _{CC} + 0.5 V		±35	mA
I _O	DC output source or sink current per output pin	For V _O > -0.5 V or V _O < V _{CC} + 0.5 V		±25	mA
I _{CC}	DC V _{CC} or ground current			±50	mA
T _J	Maximum junction temperature			150	°C
T _{stg}	Maximum storage temperature range		-65	150	°C
	Maximum lead temperature (soldering 10s)SOIC - lead tips only			300	°C

- (1) Stresses beyond those listed under *absolute maximum ratings* may cause permanent damage to the device. These are stress ratings only and functional operation of the device at these or any other conditions beyond those indicated under *recommended operating conditions* is not implied. Exposure to absolute-maximum-rated conditions for extended periods may affect device reliability.

5.2 Operating Conditions

			MIN	MAX	UNIT
V _{CC}	Supply voltage range	HC Types	2	6	V
		HCT Types	4.5	5.5	V
V _I , V _O	DC input or output voltage		0	V _{CC}	V
	Input rise and fall time	2 V		1000	ns
		4.5 V		500	
		6 V		400	
T _A	Temperature range		-55	125	°C

5.3 Thermal Information

THERMAL METRIC		N (PDIP)	D (SOIC)	UNIT
		16 PINS	16 PINS	
R _{θJA}	Junction-to-ambient thermal resistance ⁽¹⁾	67	73	°C/W

- (1) The package thermal impedance is calculated in accordance with JESD 51 - 7

5.4 Electrical Characteristics

PARAMETER		TEST CONDITIONS		V _{CC} (V)	25°C			-40°C to 85°C		-55°C to 125°C		UNIT
		V _I (V)	I _O (mA)		MIN	TYP	MAX	MIN	MAX	MIN	MAX	
HC TYPES												
V _{IH}	High level input voltage			2	1.5			1.5		1.5		V
				4.5	3.15			3.15		3.15		
				6	4.2			4.2		4.2		
V _{IL}	Low level input voltage			2	0.5			0.5		0.5		V
				4.5	1.35			1.35		1.35		
				6	1.8			1.8		1.8		
V _{OH}	High level output voltage CMOS loads	V _{IH} or V _{IL}	-0.02	2	1.9			1.9		1.9		V
			-0.02	4.5	4.4			4.4		4.4		
	-0.02		6	5.9			5.9		5.9			
	High level output voltage TTL loads		-6	4.5	3.98			3.84		3.7		
-7.8		6	5.48			5.34		5.2				
V _{OL}	Low level output voltage CMOS loads	V _{IH} or V _{IL}	0.02	2	0.1			0.1		0.1		V
			0.02	4.5	0.1			0.1		0.1		
	0.02		6	0.1			0.1		0.1			
	Low level output voltage TTL loads		6	4.5	0.26			0.33		0.4		
7.8		6	0.26			0.33		0.4				
I _I	Input leakage current	V _{CC} or GND		6	±0.1			±1		±1		µA
I _{CC}	Quiescent device current	V _{CC} or GND	0	6	8			80		160		µA
I _{OZ}	Three-state leakage current	V _{IH} or V _{IL}	V _O = V _{CC} or GND	6	±0.5			±5		±10		µA
HCT TYPES												
V _{IH}	High level input voltage			4.5 to 5.5	2			2		2		V
V _{IL}	Low level input voltage			4.5 to 5.5	0.8			0.8		0.8		V
V _{OH}	High level output voltage CMOS loads	V _{IH} or V _{IL}	-0.02	4.5	4.4			4.4		4.4		V
	High level output voltage TTL loads		-4	4.5	3.98			3.84		3.7		
V _{OL}	Low level output voltage CMOS loads	V _{IH} or V _{IL}	0.02	4.5	0.1			0.1		0.1		V
	Low level output voltage TTL loads		4	4.5	0.26			0.33		0.4		
I _I	Input leakage current	V _{CC} or GND	0	5.5	±0.1			±1		±1		µA
I _{CC}	Quiescent device current	V _{CC} or GND	0	5.5	8			80		160		µA
ΔI _{CC}	Additional supply current per input pin: 1 Unit Load ⁽¹⁾	V _{CC} - 2.1		4.5 to 5.5	100 360			450		490		µA
I _{OZ}	Three-state leakage current	V _{IL} or V _{IH}	V _O = V _{CC} or GND	5.5	±0.5			±5		±10		µA

(1) For dual-supply systems theoretical worst case (V_I = 2.4 V, V_{CC} = 5.5 V) specification is 1.8 mA

5.5 HCT Input Loading Table

Input	Unit Loads ⁽¹⁾
\overline{OE}	0.6
All others	0.55

(1) Unit Load is ΔI_{CC} limit specified in Section 5.4, e.g., 360 μ A max at 25°C.

5.6 Switching Characteristics

$t_r, t_f = 6$ ns

PARAMETER		TEST CONDITIONS	V_{CC} (V)	25°C		40°C to 85°C	55°C to 125°C	UNIT
				TYP	MAX	MAX	MAX	
HC TYPES								
t_{PLH}, t_{PHL}	Propagation delay, data to outputs HC/HCT 365	$C_L = 50$ pF	2	105	130	160	ns	
			4.5	21	26	32	ns	
			6	18	22	27	ns	
		$C_L = 15$ pF	5	8			ns	
t_{PLH}, t_{PHL}	Propagation delay, data to outputs HC 366	$C_L = 50$ pF	2	110	140	165	ns	
			4.5	22	28	33	ns	
			6	19	24	28	ns	
		$C_L = 15$ pF	5	9			ns	
t_{PLH}, t_{PHL}	Propagation delay time, output enable and disable to outputs	$C_L = 50$ pF	2	150	190	225	ns	
			4.5	30	38	45	ns	
			6	26	33	38	ns	
		$C_L = 15$ pF	5	12			ns	
t_{TLH}, t_{THL}	Output transition time	$C_L = 50$ pF	2	60	75	90	ns	
			4.5	12	15	18	ns	
			6	10	13	15	ns	
C_I	Input capacitance			10	10	10	pF	
C_O	Three-state output capacitance			20	20	20	pF	
C_{PD}	Power dissipation capacitance ⁽¹⁾ ⁽²⁾		5	40			pF	
HCT TYPES								
t_{PLH}, t_{PHL}	Propagation delay, data to outputs HC/HCT 365	$C_L = 50$ pF	4.5	25	31	38	ns	
							ns	
		$C_L = 15$ pF	5	9			ns	
							ns	
t_{PLH}, t_{PHL}	Propagation delay, data to outputs HC 366	$C_L = 50$ pF	4.5	27	34	41	ns	
							ns	
		$C_L = 15$ pF	5	11			ns	
t_{PLH}, t_{PHL}	Propagation delay time, output enable and disable to outputs	$C_L = 50$ pF	4.5	35	44	53	ns	
							ns	
		$C_L = 15$ pF	5	14			ns	
t_{TLH}, t_{THL}	Output transition time	$C_L = 50$ pF	4.5	12	15	18	ns	
C_{IN}	Input capacitance			10	10	10	pF	
C_O	Three-stage capacitance			20	20	20	pF	
C_{PD}	Power dissipation capacitance ⁽¹⁾ ⁽²⁾		5	42			pF	

(1) C_{PD} is used to determine the dynamic power consumption, per buffer.

(2) $P_D = V_{CC}^2 f_i (C_{PD} + C_I)$ where f_i = input frequency, C_L = output load capacitance, V_{CC} = supply voltage.

6 Parameter Measurement Information

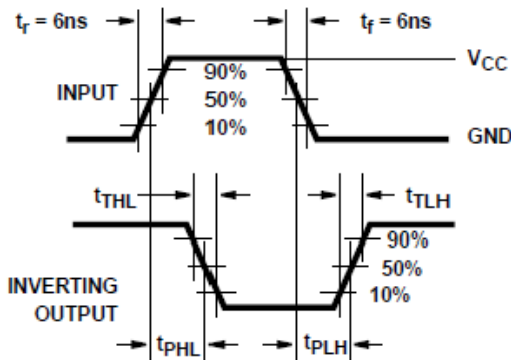

Figure 6-1. HC Transition Times and Propagation Delay Times, Combination Logic

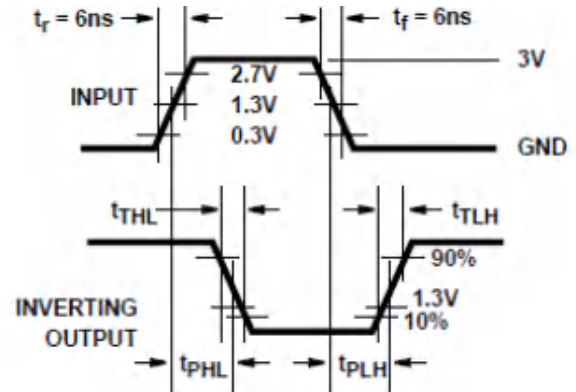

Figure 6-2. HCT Transition Times and Propagation Delay Times, Combination Logic

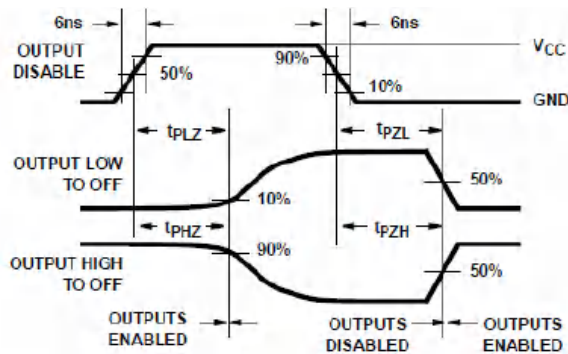

Figure 6-3. HC Three-State Propagation Delay Waveform

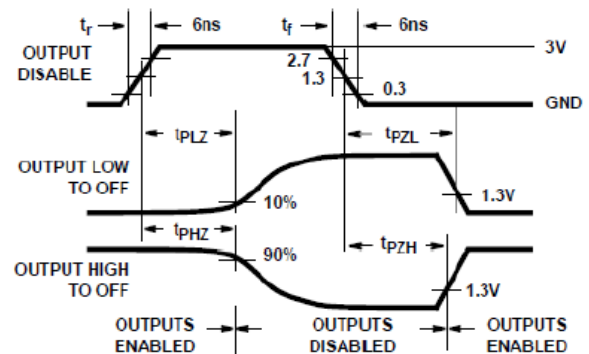
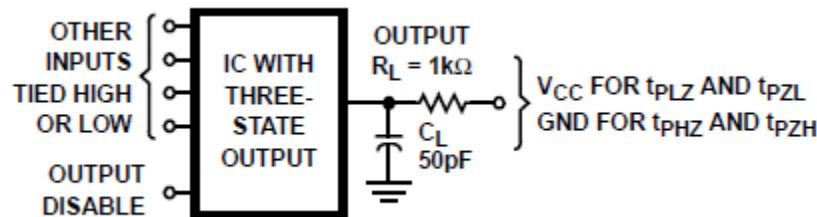

Figure 6-4. HCT Three-State Propagation Delay Waveform



- A. Open drain waveforms t_{pLZ} and t_{pZL} are the same as those for three-state shown on the left. The test circuit is output $R_L = 1\text{ k}\Omega$ to V_{CC} , $C_L = 50\text{ pF}$.

Figure 6-5. HC and HCT Three-State Propagation Delay Test Circuit

7 Detailed Description

7.1 Overview

The 'HC365, 'HCT365, and 'HC366 silicon gate CMOS three-state buffers are general purpose high-speed non-inverting and inverting buffers. They have high drive current outputs which enable high speed operation even when driving large bus capacitances. These circuits possess the low power dissipation of CMOS circuitry, yet have speeds comparable to low power Schottky TTL circuits. Both circuits are capable of driving up to 15 low power Schottky inputs.

The 'HC365 and 'HCT365 are non-inverting buffers, whereas the 'HC366 is an inverting buffer. These devices have two three-state control inputs ($\overline{OE1}$ and $\overline{OE2}$) which are NORed together to control all six gates.

The 'HCT365 logic families are speed, function and pin compatible with the standard LS logic family.

7.2 Functional Block Diagram

Functional Diagrams

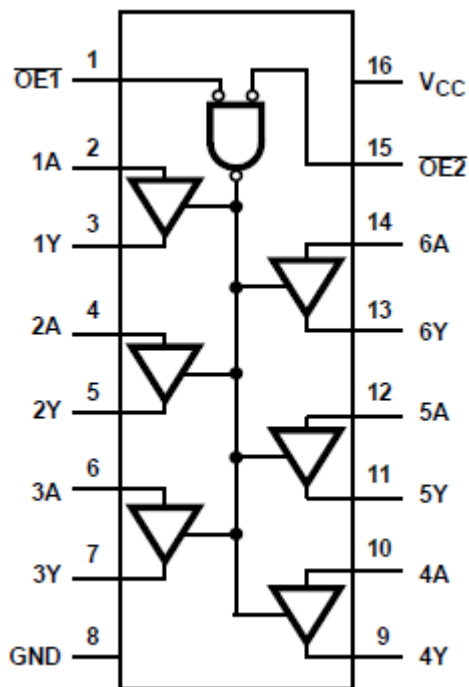

HC365, HCT365

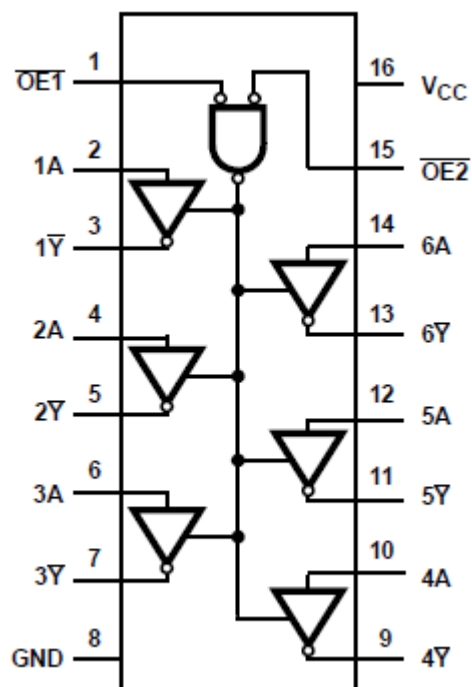

HC366

7.3 Device Functional Modes

Table 7-1. Function Table

INPUTS ⁽¹⁾			OUTPUTS (Y) ⁽²⁾	
$\overline{OE1}$	$\overline{OE2}$	A	HC/HCT 365	HCT 366
L	L	L	L	H
L	L	H	H	L
X	H	X	Z	Z
H	X	X	Z	Z

(1) H = High Voltage Level, L = Low Voltage Level, X = Don't Care

(2) H = Driving High, L = Driving Low, Z = High Impedance State

8 Power Supply Recommendations

The power supply can be any voltage between the minimum and maximum supply voltage rating located in the *Recommended Operating Conditions*. Each V_{CC} terminal should have a good bypass capacitor to prevent power disturbance. A 0.1- μ F capacitor is recommended for this device. It is acceptable to parallel multiple bypass caps to reject different frequencies of noise. The 0.1- μ F and 1- μ F capacitors are commonly used in parallel. The bypass capacitor should be installed as close to the power terminal as possible for best results.

9 Layout

9.1 Layout Guidelines

When using multiple-input and multiple-channel logic devices inputs must not ever be left floating. In many cases, functions or parts of functions of digital logic devices are unused; for example, when only two inputs of a triple-input AND gate are used or only 3 of the 4 buffer gates are used. Such unused input pins must not be left unconnected because the undefined voltages at the outside connections result in undefined operational states. All unused inputs of digital logic devices must be connected to a logic high or logic low voltage, as defined by the input voltage specifications, to prevent them from floating. The logic level that must be applied to any particular unused input depends on the function of the device. Generally, the inputs are tied to GND or V_{CC} , whichever makes more sense for the logic function or is more convenient.

10 Device and Documentation Support

TI offers an extensive line of development tools. Tools and software to evaluate the performance of the device, generate code, and develop solutions are listed below.

10.1 Receiving Notification of Documentation Updates

To receive notification of documentation updates, navigate to the device product folder on ti.com. Click on *Subscribe to updates* to register and receive a weekly digest of any product information that has changed. For change details, review the revision history included in any revised document.

10.2 Support Resources

TI E2E™ [support forums](#) are an engineer's go-to source for fast, verified answers and design help — straight from the experts. Search existing answers or ask your own question to get the quick design help you need.

Linked content is provided "AS IS" by the respective contributors. They do not constitute TI specifications and do not necessarily reflect TI's views; see TI's [Terms of Use](#).

10.3 Trademarks

TI E2E™ is a trademark of Texas Instruments.
All trademarks are the property of their respective owners.

10.4 Electrostatic Discharge Caution



This integrated circuit can be damaged by ESD. Texas Instruments recommends that all integrated circuits be handled with appropriate precautions. Failure to observe proper handling and installation procedures can cause damage.

ESD damage can range from subtle performance degradation to complete device failure. Precision integrated circuits may be more susceptible to damage because very small parametric changes could cause the device not to meet its published specifications.

10.5 Glossary

[TI Glossary](#) This glossary lists and explains terms, acronyms, and definitions.

11 Mechanical, Packaging, and Orderable Information

The following pages include mechanical, packaging, and orderable information. This information is the most current data available for the designated devices. This data is subject to change without notice and revision of this document. For browser-based versions of this data sheet, refer to the left-hand navigation.

PACKAGING INFORMATION

Orderable Device	Status (1)	Package Type	Package Drawing	Pins	Package Qty	Eco Plan (2)	Lead finish/ Ball material (6)	MSL Peak Temp (3)	Op Temp (°C)	Device Marking (4/5)	Samples
CD54HC365F3A	ACTIVE	CDIP	J	16	25	Non-RoHS & Green	SNPB	N / A for Pkg Type	-55 to 125	8500101EA CD54HC365F3A	Samples
CD54HC366F3A	ACTIVE	CDIP	J	16	25	Non-RoHS & Green	SNPB	N / A for Pkg Type	-55 to 125	5962-8682801EA CD54HC366F3A	Samples
CD54HCT365F3A	ACTIVE	CDIP	J	16	25	Non-RoHS & Green	SNPB	N / A for Pkg Type	-55 to 125	CD54HCT365F3A	Samples
CD74HC365E	ACTIVE	PDIP	N	16	25	RoHS & Green	NIPDAU	N / A for Pkg Type	-55 to 125	CD74HC365E	Samples
CD74HC365M	OBSOLETE	SOIC	D	16		TBD	Call TI	Call TI	-55 to 125	HC365M	
CD74HC365M96	ACTIVE	SOIC	D	16	2500	RoHS & Green	NIPDAU	Level-1-260C-UNLIM	-55 to 125	HC365M	Samples
CD74HC365MT	OBSOLETE	SOIC	D	16		TBD	Call TI	Call TI	-55 to 125	HC365M	
CD74HC366E	ACTIVE	PDIP	N	16	25	RoHS & Green	NIPDAU	N / A for Pkg Type	-55 to 125	CD74HC366E	Samples
CD74HC366M	OBSOLETE	SOIC	D	16		TBD	Call TI	Call TI	-55 to 125	HC366M	
CD74HC366M96	ACTIVE	SOIC	D	16	2500	RoHS & Green	NIPDAU	Level-1-260C-UNLIM	-55 to 125	HC366M	Samples
CD74HCT365E	ACTIVE	PDIP	N	16	25	RoHS & Green	NIPDAU	N / A for Pkg Type	-55 to 125	CD74HCT365E	Samples
CD74HCT365M	OBSOLETE	SOIC	D	16		TBD	Call TI	Call TI	-55 to 125	HCT365M	
CD74HCT365M96	ACTIVE	SOIC	D	16	2500	RoHS & Green	NIPDAU SN	Level-1-260C-UNLIM	-55 to 125	HCT365M	Samples

(1) The marketing status values are defined as follows:

ACTIVE: Product device recommended for new designs.

LIFEBUY: TI has announced that the device will be discontinued, and a lifetime-buy period is in effect.

NRND: Not recommended for new designs. Device is in production to support existing customers, but TI does not recommend using this part in a new design.

PREVIEW: Device has been announced but is not in production. Samples may or may not be available.

OBSOLETE: TI has discontinued the production of the device.

(2) **RoHS:** TI defines "RoHS" to mean semiconductor products that are compliant with the current EU RoHS requirements for all 10 RoHS substances, including the requirement that RoHS substance do not exceed 0.1% by weight in homogeneous materials. Where designed to be soldered at high temperatures, "RoHS" products are suitable for use in specified lead-free processes. TI may reference these types of products as "Pb-Free".

RoHS Exempt: TI defines "RoHS Exempt" to mean products that contain lead but are compliant with EU RoHS pursuant to a specific EU RoHS exemption.

Green: TI defines "Green" to mean the content of Chlorine (Cl) and Bromine (Br) based flame retardants meet JS709B low halogen requirements of <=1000ppm threshold. Antimony trioxide based flame retardants must also meet the <=1000ppm threshold requirement.

(3) MSL, Peak Temp. - The Moisture Sensitivity Level rating according to the JEDEC industry standard classifications, and peak solder temperature.

(4) There may be additional marking, which relates to the logo, the lot trace code information, or the environmental category on the device.

(5) Multiple Device Markings will be inside parentheses. Only one Device Marking contained in parentheses and separated by a "~" will appear on a device. If a line is indented then it is a continuation of the previous line and the two combined represent the entire Device Marking for that device.

(6) Lead finish/Ball material - Orderable Devices may have multiple material finish options. Finish options are separated by a vertical ruled line. Lead finish/Ball material values may wrap to two lines if the finish value exceeds the maximum column width.

Important Information and Disclaimer:The information provided on this page represents TI's knowledge and belief as of the date that it is provided. TI bases its knowledge and belief on information provided by third parties, and makes no representation or warranty as to the accuracy of such information. Efforts are underway to better integrate information from third parties. TI has taken and continues to take reasonable steps to provide representative and accurate information but may not have conducted destructive testing or chemical analysis on incoming materials and chemicals. TI and TI suppliers consider certain information to be proprietary, and thus CAS numbers and other limited information may not be available for release.

In no event shall TI's liability arising out of such information exceed the total purchase price of the TI part(s) at issue in this document sold by TI to Customer on an annual basis.

OTHER QUALIFIED VERSIONS OF CD54HC365, CD54HC366, CD54HCT365, CD74HC365, CD74HC366, CD74HCT365 :

- Catalog : [CD74HC365](#), [CD74HC366](#), [CD74HCT365](#)
- Automotive : [CD74HC366-Q1](#), [CD74HC366-Q1](#)
- Military : [CD54HC365](#), [CD54HC366](#), [CD54HCT365](#)

NOTE: Qualified Version Definitions:

- Catalog - TI's standard catalog product
- Automotive - Q100 devices qualified for high-reliability automotive applications targeting zero defects
- Military - QML certified for Military and Defense Applications

TAPE AND REEL INFORMATION

QUADRANT ASSIGNMENTS FOR PIN 1 ORIENTATION IN TAPE

*All dimensions are nominal

Device	Package Type	Package Drawing	Pins	SPQ	Reel Diameter (mm)	Reel Width W1 (mm)	A0 (mm)	B0 (mm)	K0 (mm)	P1 (mm)	W (mm)	Pin1 Quadrant
CD74HC365M96	SOIC	D	16	2500	330.0	16.4	6.5	10.3	2.1	8.0	16.0	Q1
CD74HC366M96	SOIC	D	16	2500	330.0	16.4	6.5	10.3	2.1	8.0	16.0	Q1
CD74HCT365M96	SOIC	D	16	2500	330.0	16.4	6.5	10.3	2.1	8.0	16.0	Q1

TAPE AND REEL BOX DIMENSIONS

*All dimensions are nominal

Device	Package Type	Package Drawing	Pins	SPQ	Length (mm)	Width (mm)	Height (mm)
CD74HC365M96	SOIC	D	16	2500	340.5	336.1	32.0
CD74HC366M96	SOIC	D	16	2500	340.5	336.1	32.0
CD74HCT365M96	SOIC	D	16	2500	356.0	356.0	35.0

TUBE

*All dimensions are nominal

Device	Package Name	Package Type	Pins	SPQ	L (mm)	W (mm)	T (μm)	B (mm)
CD74HC365E	N	PDIP	16	25	506	13.97	11230	4.32
CD74HC365E	N	PDIP	16	25	506	13.97	11230	4.32
CD74HC366E	N	PDIP	16	25	506	13.97	11230	4.32
CD74HC366E	N	PDIP	16	25	506	13.97	11230	4.32
CD74HCT365E	N	PDIP	16	25	506	13.97	11230	4.32
CD74HCT365E	N	PDIP	16	25	506	13.97	11230	4.32

D (R-PDSO-G16)

PLASTIC SMALL OUTLINE



- NOTES:
- A. All linear dimensions are in inches (millimeters).
 - B. This drawing is subject to change without notice.
 - C. Body length does not include mold flash, protrusions, or gate burrs. Mold flash, protrusions, or gate burrs shall not exceed 0.006 (0,15) each side.
 - D. Body width does not include interlead flash. Interlead flash shall not exceed 0.017 (0,43) each side.
 - E. Reference JEDEC MS-012 variation AC.

J (R-GDIP-T**)

14 LEADS SHOWN

CERAMIC DUAL IN-LINE PACKAGE



DIM \ PINS **	14	16	18	20
A	0.300 (7,62) BSC	0.300 (7,62) BSC	0.300 (7,62) BSC	0.300 (7,62) BSC
B MAX	0.785 (19,94)	.840 (21,34)	0.960 (24,38)	1.060 (26,92)
B MIN	—	—	—	—
C MAX	0.300 (7,62)	0.300 (7,62)	0.310 (7,87)	0.300 (7,62)
C MIN	0.245 (6,22)	0.245 (6,22)	0.220 (5,59)	0.245 (6,22)



4040083/F 03/03

- NOTES:
- All linear dimensions are in inches (millimeters).
 - This drawing is subject to change without notice.
 - This package is hermetically sealed with a ceramic lid using glass frit.
 - Index point is provided on cap for terminal identification only on press ceramic glass frit seal only.
 - Falls within MIL STD 1835 GDIP1-T14, GDIP1-T16, GDIP1-T18 and GDIP1-T20.

N (R-PDIP-T**)

PLASTIC DUAL-IN-LINE PACKAGE

16 PINS SHOWN



4040049/E 12/2002

- NOTES:
- A. All linear dimensions are in inches (millimeters).
 - B. This drawing is subject to change without notice.
 - Falls within JEDEC MS-001, except 18 and 20 pin minimum body length (Dim A).
 - The 20 pin end lead shoulder width is a vendor option, either half or full width.

IMPORTANT NOTICE AND DISCLAIMER

TI PROVIDES TECHNICAL AND RELIABILITY DATA (INCLUDING DATA SHEETS), DESIGN RESOURCES (INCLUDING REFERENCE DESIGNS), APPLICATION OR OTHER DESIGN ADVICE, WEB TOOLS, SAFETY INFORMATION, AND OTHER RESOURCES "AS IS" AND WITH ALL FAULTS, AND DISCLAIMS ALL WARRANTIES, EXPRESS AND IMPLIED, INCLUDING WITHOUT LIMITATION ANY IMPLIED WARRANTIES OF MERCHANTABILITY, FITNESS FOR A PARTICULAR PURPOSE OR NON-INFRINGEMENT OF THIRD PARTY INTELLECTUAL PROPERTY RIGHTS.

These resources are intended for skilled developers designing with TI products. You are solely responsible for (1) selecting the appropriate TI products for your application, (2) designing, validating and testing your application, and (3) ensuring your application meets applicable standards, and any other safety, security, regulatory or other requirements.

These resources are subject to change without notice. TI grants you permission to use these resources only for development of an application that uses the TI products described in the resource. Other reproduction and display of these resources is prohibited. No license is granted to any other TI intellectual property right or to any third party intellectual property right. TI disclaims responsibility for, and you will fully indemnify TI and its representatives against, any claims, damages, costs, losses, and liabilities arising out of your use of these resources.

TI's products are provided subject to [TI's Terms of Sale](#) or other applicable terms available either on [ti.com](https://www.ti.com) or provided in conjunction with such TI products. TI's provision of these resources does not expand or otherwise alter TI's applicable warranties or warranty disclaimers for TI products.

TI objects to and rejects any additional or different terms you may have proposed.

Mailing Address: Texas Instruments, Post Office Box 655303, Dallas, Texas 75265
Copyright © 2024, Texas Instruments Incorporated