

8-Line to 1-Line Data Selector/Multiplexer/Register With 3-State Outputs

SCHS277D - November 1997 - Revised May 2003

Features

- HC/HCT354
 - Transparent Data and Select Latches
- Buffered Inputs
- Three-State Complementary Outputs
- Bus Line Driving Capability
- Typical Propagation Delay: $V_{CC} = 5V$, $C_L = 15pF$, $T_A = 25^\circ C$
 - Data to Output = 18ns
- Fanout (Over Temperature Range)
 - Standard Outputs 10 LSTTL Loads
 - Bus Driver Outputs 15 LSTTL Loads
- Wide Operating Temperature Range . . . $-55^\circ C$ to $125^\circ C$
- Balanced Propagation Delay and Transition Times
- Significant Power Reduction Compared to LSTTL Logic ICs
- HC Types
 - 2V to 6V Operation
 - High Noise Immunity: $N_{IL} = 30\%$, $N_{IH} = 30\%$ of V_{CC} at $V_{CC} = 5V$
- HCT Types
 - 4.5V to 5.5V Operation
 - Direct LSTTL Input Logic Compatibility, $V_{IL} = 0.8V$ (Max), $V_{IH} = 2V$ (Min)
 - CMOS Input Compatibility, $I_I \leq 1\mu A$ at V_{OL} , V_{OH}

Description

The CD54HC354, CD74HC354, and CD74HCT354 are data selectors/multiplexers that select one of eight sources. In both types, the data select bits S0, S1 and S2 are stored in transparent latches that are enabled by a low latch enable input, \overline{LE} .

In the HC/HCT354 the data enable input, \overline{E} , controls transparent latches that pass data to the outputs when \overline{E} is high and latches in new data when \overline{E} is low.

In both types the three-state outputs are controlled by three output-enable inputs OE1, OE2, and OE3.

Ordering Information

PART NUMBER	TEMP. RANGE (°C)	PACKAGE
CD54HC354F3A	-55 TO 125	20 Ld CERDIP
CD74HC354E	-55 to 125	20 Ld PDIP
CD74HCT354E	-55 to 125	20 Ld PDIP

Pinout

CD54HC354
(CERDIP)
CD74HC354, CD74HCT354
(PDIP)
TOP VIEW

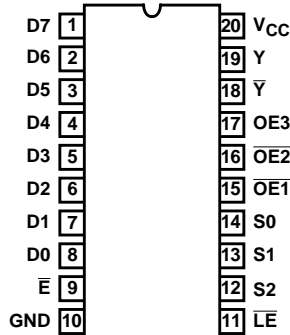

CAUTION: These devices are sensitive to electrostatic discharge. Users should follow proper IC Handling Procedures.

CD54HC354, CD74HC354, CD74HCT354

Functional Diagram

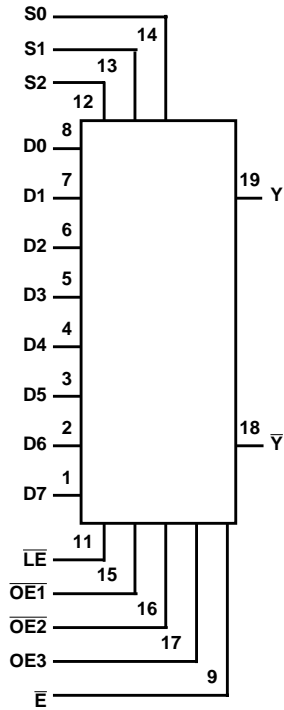

TRUTH TABLE

INPUTS							OUTPUTS	
SELECT (NOTE 1)			ENABLE DATA	OUTPUT ENABLES				
S2	S1	S0	\bar{E}	$\bar{OE1}$	$\bar{OE2}$	OE3	\bar{Y}	Y
X	X	X	X	H	X	X	Z	Z
X	X	X	X	X	H	X	Z	Z
X	X	X	X	X	X	L	Z	Z
L	L	L	L	L	L	H	$\bar{D0}$	D0
L	L	L	H	L	L	H	$\bar{D0}_n$	D0 _n
L	L	H	L	L	L	H	$\bar{D1}$	D1
L	L	H	H	L	L	H	$\bar{D1}_n$	D1 _n
L	H	L	L	L	L	H	$\bar{D2}$	D2
L	H	L	H	L	L	H	$\bar{D2}_n$	D2 _n
L	H	H	L	L	L	H	$\bar{D3}$	D3
L	H	H	H	L	L	H	$\bar{D3}_n$	D3 _n
H	L	L	L	L	L	H	$\bar{D4}$	D4
H	L	L	H	L	L	H	$\bar{D4}_n$	D4 _n
H	L	H	L	L	L	H	$\bar{D5}$	D5
H	L	H	H	L	L	H	$\bar{D5}_n$	D5 _n
H	H	L	L	L	L	H	$\bar{D6}$	D6
H	H	L	H	L	L	H	$\bar{D6}_n$	D6 _n

CD54HC354, CD74HC354, CD74HCT354

TRUTH TABLE (Continued)

INPUTS							OUTPUTS	
SELECT (NOTE 1)			ENABLE DATA	OUTPUT ENABLES				
S2	S1	S0	\bar{E}	$\bar{OE1}$	$\bar{OE2}$	OE3	\bar{Y}	Y
H	H	H	L	L	L	H	$\bar{D7}$	D7
H	H	H	H	L	L	H	$\bar{D7}_n$	D7 _n

H = High Voltage Level (Steady State); L = Low Voltage Level (Steady State); X = Don't Care; Z = High Impedance State (Off State); D0_n...D7_n = the level of steady-state inputs D0 through D7, respectively, before the most recent low-to-high transition of data control.

NOTE:

1. This column shows the input address setup with \bar{LE} low.

Block Diagram

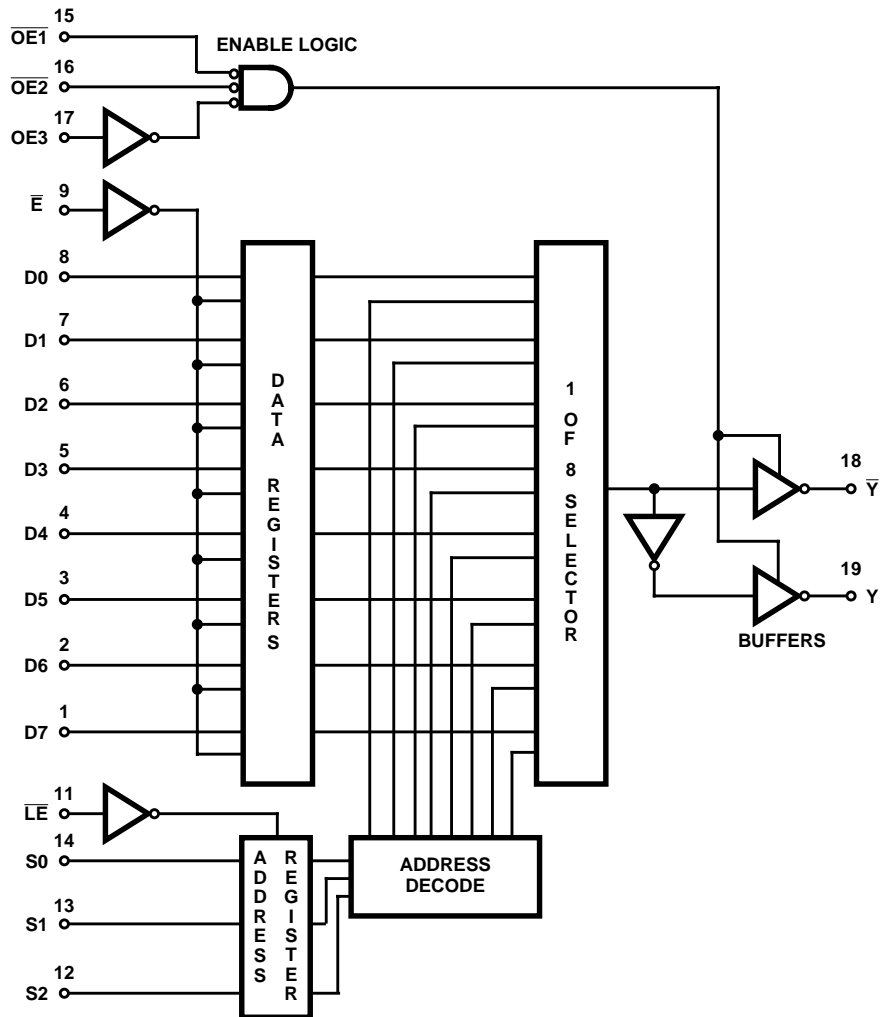

Logic Diagram

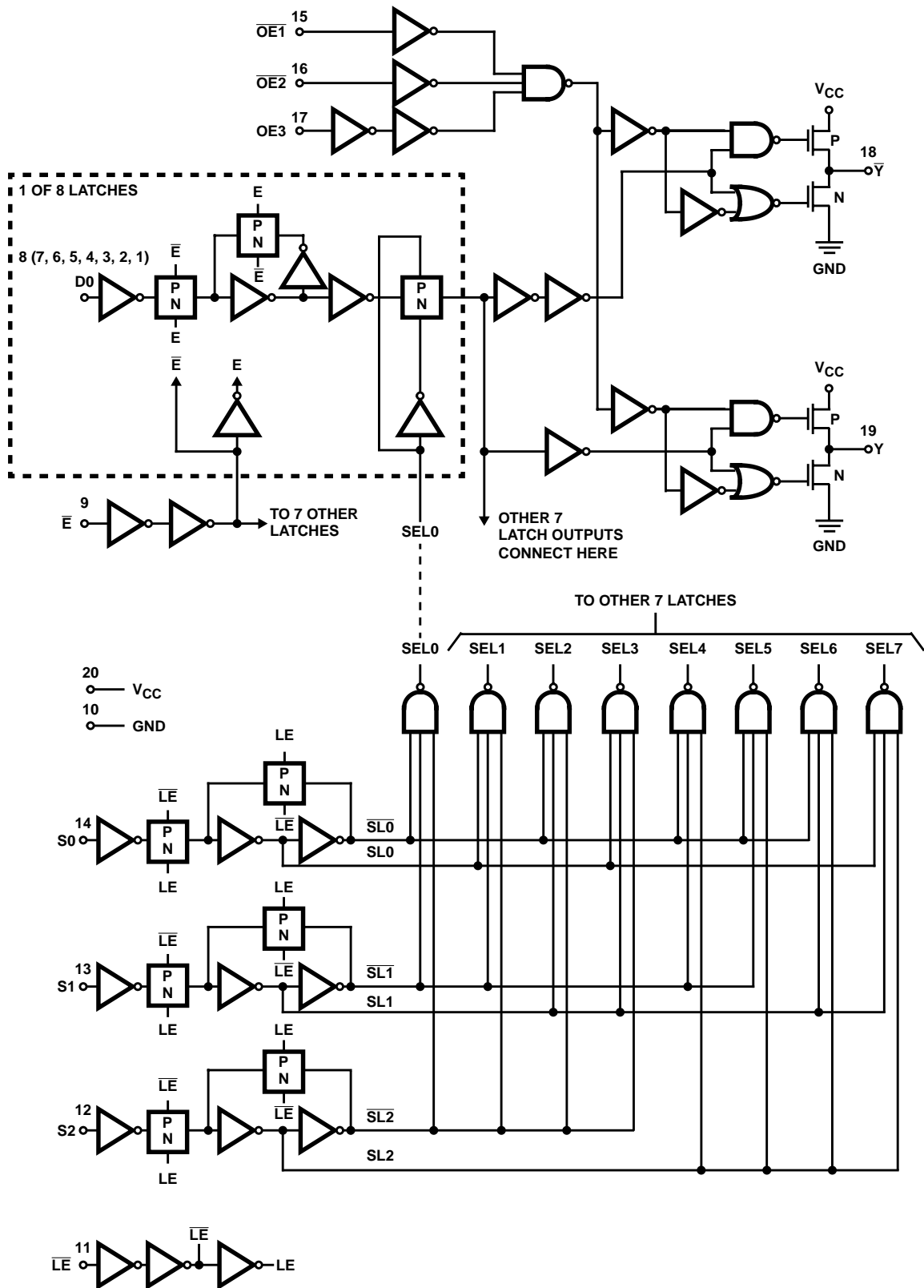

FIGURE 1. HC/HCT354 LOGIC DIAGRAM

CD54HC354, CD74HC354, CD74HCT354

Absolute Maximum Ratings

DC Supply Voltage, V_{CC}	-0.5V to 7V
DC Input Diode Current, I_{IK}	
For $V_I < -0.5V$ or $V_I > V_{CC} + 0.5V$	$\pm 20mA$
DC Output Diode Current, I_{OK}	
For $V_O < -0.5V$ or $V_O > V_{CC} + 0.5V$	$\pm 20mA$
DC Drain Current, per Output, I_O	
For $-0.5V < V_O < V_{CC} + 0.5V$	$\pm 35mA$
DC Output Source or Sink Current per Output Pin, I_O	
For $V_O > -0.5V$ or $V_O < V_{CC} + 0.5V$	$\pm 25mA$
DC V_{CC} or Ground Current, I_{CC}	$\pm 50mA$

Thermal Information

Thermal Resistance (Typical, Note 2)	θ_{JA} ($^{\circ}C/W$)
E (PDIP) Package	69
Maximum Junction Temperature	$150^{\circ}C$
Maximum Storage Temperature Range	$-65^{\circ}C$ to $150^{\circ}C$
Maximum Lead Temperature (Soldering 10s)	$300^{\circ}C$ (SOIC - Lead Tips Only)

Operating Conditions

Temperature Range, T_A	$-55^{\circ}C$ to $125^{\circ}C$
Supply Voltage Range, V_{CC}	
HC Types2V to 6V
HCT Types	4.5V to 5.5V
DC Input or Output Voltage, V_I, V_O	0V to V_{CC}
Input Rise and Fall Time	
2V	1000ns (Max)
4.5V	500ns (Max)
6V	400ns (Max)

CAUTION: Stresses above those listed in "Absolute Maximum Ratings" may cause permanent damage to the device. This is a stress only rating and operation of the device at these or any other conditions above those indicated in the operational sections of this specification is not implied.

NOTE:

- The package thermal impedance is calculated in accordance with JESD 51-7.

DC Electrical Specifications

PARAMETER	SYMBOL	TEST CONDITIONS		V_{CC} (V)	25 $^{\circ}C$			-40 $^{\circ}C$ TO 85 $^{\circ}C$		-55 $^{\circ}C$ TO 125 $^{\circ}C$		UNITS
		V_I (V)	I_O (mA)		MIN	TYP	MAX	MIN	MAX	MIN	MAX	
HC TYPES												
High Level Input Voltage	V_{IH}	-	-	2	1.5	-	-	1.5	-	1.5	-	V
				4.5	3.15	-	-	3.15	-	3.15	-	V
				6	4.2	-	-	4.2	-	4.2	-	V
Low Level Input Voltage	V_{IL}	-	-	2	-	-	0.5	-	0.5	-	0.5	V
				4.5	-	-	1.35	-	1.35	-	1.35	V
				6	-	-	1.8	-	1.8	-	1.8	V
High Level Output Voltage CMOS Loads	V_{OH}	V_{IH} or V_{IL}	-0.02	2	1.9	-	-	1.9	-	1.9	-	V
			-0.02	4.5	4.4	-	-	4.4	-	4.4	-	V
			-0.02	6	5.9	-	-	5.9	-	5.9	-	V
High Level Output Voltage TTL Loads (Bus Driver)	V_{OH}	V_{IH} or V_{IL}	-6	4.5	3.98	-	-	3.84	-	3.7	-	V
			-7.8	6	5.48	-	-	5.34	-	5.2	-	V
Low Level Output Voltage CMOS Loads	V_{OL}	V_{IH} or V_{IL}	0.02	2	-	-	0.1	-	0.1	-	0.1	V
			0.02	4.5	-	-	0.1	-	0.1	-	0.1	V
			0.02	6	-	-	0.1	-	0.1	-	0.1	V
Low Level Output Voltage TTL Loads (Bus Driver)	V_{OL}	V_{IH} or V_{IL}	6	4.5	-	-	0.26	-	0.33	-	0.4	V
			7.8	6	-	-	0.26	-	0.33	-	0.4	V
Input Leakage Current	I_I	V_{CC} or GND	-	6	-	-	± 0.1	-	± 1	-	± 1	μA

CD54HC354, CD74HC354, CD74HCT354

DC Electrical Specifications (Continued)

PARAMETER	SYMBOL	TEST CONDITIONS		V _{CC} (V)	25°C			-40°C TO 85°C		-55°C TO 125°C		UNITS
		V _I (V)	I _O (mA)		MIN	TYP	MAX	MIN	MAX	MIN	MAX	
Quiescent Device Current	I _{CC}	V _{CC} or GND	0	6	-	-	8	-	80	-	160	μA
Three-State Leakage Current	I _{OZ}	V _{IL} or V _{IH}	V _O = V _{CC} or GND	6	-	-	±0.5	-	±5.0	-	±10	μA
HCT TYPES												
High Level Input Voltage	V _{IH}	-	-	4.5 to 5.5	2	-	-	2	-	2	-	V
Low Level Input Voltage	V _{IL}	-	-	4.5 to 5.5	-	-	0.8	-	0.8	-	0.8	V
High Level Output Voltage CMOS Loads	V _{OH}	V _{IH} or V _{IL}	-0.02	4.5	4.4	-	-	4.4	-	4.4	-	V
High Level Output Voltage TTL Loads			-4	4.5	3.98	-	-	3.84	-	3.7	-	V
Low Level Output Voltage CMOS Loads	V _{OL}	V _{IH} or V _{IL}	0.02	4.5	-	-	0.1	-	0.1	-	0.1	V
Low Level Output Voltage TTL Loads			4	4.5	-	-	0.26	-	0.33	-	0.4	V
Input Leakage Current	I _I	V _{CC} to GND	-	5.5	-	-	±0.1	-	±1	-	±1	μA
Quiescent Device Current	I _{CC}	V _{CC} or GND	0	5.5	-	-	8	-	80	-	160	μA
Additional Quiescent Device Current Per Input Pin: 1 Unit Load	ΔI _{CC} (Note 3)	V _{CC} -2.1	-	4.5 to 5.5	-	100	360	-	450	-	490	μA
Three-State Leakage Current	I _{OZ}	V _{IL} or V _{IH}	V _O = V _{CC} or GND	5.5	-	-	±0.5	-	±5.0	-	±10	μA

NOTE:

3. For dual-supply systems theoretical worst case (V_I = 2.4V, V_{CC} = 5.5V) specification is 1.8mA.

HCT Input Loading Table

INPUT	UNIT LOADS
D0-D7	0.50
S0, S1, S3	0.70
OE1, OE2	0.80
OE3	0.25
LE	0.25
E	0.60

NOTE: Unit Load is ΔI_{CC} limit specified in DC Electrical Specifications table, e.g., 360μA max at 25°C.

CD54HC354, CD74HC354, CD74HCT354

Prerequisite For Switching Specifications

PARAMETER	SYMBOL	TEST CONDITIONS	V _{CC} (V)	25°C			-40°C TO 85°C		-55°C TO 125°C		UNITS
				MIN	TYP	MAX	MIN	MAX	MIN	MAX	
HC TYPES											
\bar{E} Pulse Width	t_{PLH}, t_{PHL}	-	2	80	-	-	100	-	120	-	ns
			4.5	16	-	-	20	-	24	-	ns
			6	14	-	-	17	-	20	-	ns
\bar{LE} Pulse Width	t_{PLH}, t_{PHL}	-	2	80	-	-	100	-	120	-	ns
			4.5	16	-	-	20	-	24	-	ns
			6	14	-	-	17	-	20	-	ns
Set-up Times Dn $\rightarrow \bar{E}$	t_{SU}	-	2	50	-	-	65	-	75	-	ns
			4.5	10	-	-	13	-	15	-	ns
			6	9	-	-	11	-	13	-	ns
Set-up Times Sn $\rightarrow \bar{LE}$	t_{SU}	-	2	50	-	-	65	-	75	-	ns
			4.5	10	-	-	13	-	15	-	ns
			6	9	-	-	11	-	13	-	ns
Hold Times Dn $\rightarrow \bar{E}$	t_H	-	2	45	-	-	55	-	70	-	ns
			4.5	9	-	-	11	-	14	-	ns
			6	8	-	-	9	-	12	-	ns
Hold Times Sn $\rightarrow \bar{LE}$	t_H	-	2	45	-	-	55	-	70	-	ns
			4.5	9	-	-	11	-	14	-	ns
			6	8	-	-	9	-	12	-	ns
HCT TYPES											
\bar{E} Pulse Width	t_{PLH}, t_{PHL}	-	4.5	16	-	-	20	-	24	-	ns
\bar{LE} Pulse Width	t_{PLH}, t_{PHL}	-	4.5	16	-	-	20	-	24	-	ns
Set-up Times Dn $\rightarrow \bar{E}$	t_{SU}	-	4.5	10	-	-	13	-	15	-	ns
Set-up Times Sn $\rightarrow \bar{LE}$	t_{SU}	-	4.5	10	-	-	13	-	15	-	ns
Hold Times Dn $\rightarrow \bar{E}$	t_H	-	4.5	9	-	-	11	-	14	-	ns
Hold Times Sn $\rightarrow \bar{LE}$	t_H	-	4.5	9	-	-	11	-	14	-	ns

Switching Specifications Input $t_r, t_f = 6ns$

PARAMETER	SYMBOL	TEST CONDITIONS	V _{CC} (V)	25°C		-40°C TO 85°C	-55°C TO 125°C	UNITS
				TYP	MAX	MAX	MAX	
HC TYPES								
Propagation Delay, Dn $\rightarrow Y, \bar{Y}$	t_{PLH}, t_{PHL}	$C_L = 50pF$	2	-	210	265	315	ns
			4.5	-	42	53	63	ns
			6	-	36	45	54	ns
		$C_L = 15pF$	5	18	-	-	-	ns
Propagation Delay, $\bar{E} \rightarrow Y, \bar{Y}$	t_{PLH}, t_{PHL}	$C_L = 50pF$	2	-	250	315	375	ns
			4.5	-	50	63	75	ns
			6	-	43	54	64	ns
		$C_L = 15pF$	5	21	-	-	-	ns

CD54HC354, CD74HC354, CD74HCT354

Switching Specifications Input $t_r, t_f = 6\text{ns}$ (Continued)

PARAMETER	SYMBOL	TEST CONDITIONS	V_{CC} (V)	25°C		-40°C TO 85°C	-55°C TO 125°C	UNITS
				TYP	MAX	MAX	MAX	
Propagation Delay, $S_n \rightarrow Y, \bar{Y}$	t_{PLH}, t_{PHL}	$C_L = 50\text{pF}$	2	-	260	325	390	ns
			4.5	-	52	65	78	ns
			6	-	44	55	66	ns
		$C_L = 15\text{pF}$	5	22	-	-	-	ns
Propagation Delay, $\bar{L}\bar{E} \rightarrow Y, \bar{Y}$	t_{PLH}, t_{PHL}	$C_L = 50\text{pF}$	2	-	290	365	435	ns
			4.5	-	58	73	87	ns
			6	-	49	62	74	ns
		$C_L = 15\text{pF}$	5	24	-	-	-	ns
Output Disabling Time, $\bar{O}\bar{E}_n$ to Y, \bar{Y}	t_{PLZ}, t_{PHZ}	$C_L = 50\text{pF}$	2	-	155	195	235	ns
			4.5	-	31	39	47	ns
			6	-	26	33	40	ns
		$C_L = 15\text{pF}$	5	13	-	-	-	ns
Output Disabling Time, $O\bar{E}_3$ to Y, \bar{Y}	t_{PLZ}, t_{PHZ}	$C_L = 50\text{pF}$	2	-	155	195	235	ns
			4.5	-	31	39	47	ns
			6	-	26	33	40	ns
		$C_L = 15\text{pF}$	5	13	-	-	-	ns
Output Enabling Time, $\bar{O}\bar{E}_n$ to Y, \bar{Y}	t_{PZL}, t_{PZH}	$C_L = 50\text{pF}$	2	-	150	190	225	ns
			4.5	-	30	38	45	ns
			6	-	26	33	38	ns
		$C_L = 15\text{pF}$	5	12, 13	-	-	-	ns
Output Enabling Time, $O\bar{E}_3$ to Y, \bar{Y}	t_{PZL}, t_{PZH}	$C_L = 50\text{pF}$	2	-	160	200	240	ns
			4.5	-	32	40	48	ns
			6	-	27	34	41	ns
		$C_L = 15\text{pF}$	5	12, 13	-	-	-	ns
Output Transition Time	t_{TLH}, t_{THL}	$C_L = 50\text{pF}$	2	-	60	75	90	ns
			4.5	-	12	15	18	ns
			6	-	10	13	15	ns
Input Capacitance	C_I	-	-	-	10	10	10	pF
Three-State Capacitance	C_O	-	-	-	20	20	20	pF
Power Dissipation Capacitance (Notes 4, 5)	C_{PD}	-	5	90	-	-	-	pF
HCT TYPES								
Propagation Delay, $D_n \rightarrow Y, \bar{Y}$	t_{PLH}, t_{PHL}	$C_L = 50\text{pF}$	4.5	-	47	59	71	ns
		$C_L = 15\text{pF}$	5	20	-	-	-	ns
Propagation Delay, $\bar{E} \rightarrow Y, \bar{Y}$	t_{PLH}, t_{PHL}	$C_L = 50\text{pF}$	4.5	-	54	68	81	ns
		$C_L = 15\text{pF}$	5	23	-	-	-	ns

CD54HC354, CD74HC354, CD74HCT354

Switching Specifications Input $t_r, t_f = 6\text{ns}$ (Continued)

PARAMETER	SYMBOL	TEST CONDITIONS	V_{CC} (V)	25°C		-40°C TO 85°C	-55°C TO 125°C	UNITS
				TYP	MAX	MAX	MAX	
Propagation Delay, $S_n \rightarrow Y, \bar{Y}$	t_{PLH}, t_{PHL}	$C_L = 50\text{pF}$	4.5	-	59	74	89	ns
		$C_L = 15\text{pF}$	5	25	-	-	-	ns
Propagation Delay, $\bar{LE} \rightarrow Y, \bar{Y}$	t_{PLH}, t_{PHL}	$C_L = 50\text{pF}$	4.5	-	63	79	94	ns
		$C_L = 15\text{pF}$	5	25	-	-	-	ns
Output Disabling Time, $\bar{OE}_n \rightarrow Y, \bar{Y}$	t_{PLZ}, t_{PHZ}	$C_L = 50\text{pF}$	4.5	-	33	41	50	ns
		$C_L = 15\text{pF}$	5	13, 16	-	-	-	ns
Output Disabling Time, $OE_3 \rightarrow Y, \bar{Y}$	t_{PLZ}, t_{PHZ}	$C_L = 50\text{pF}$	4.5	-	39	49	59	ns
		$C_L = 15\text{pF}$	5	13, 16	-	-	-	ns
Output Enabling Time, $\bar{OE}_n \rightarrow Y, \bar{Y}$	t_{PZL}, t_{PZH}	$C_L = 50\text{pF}$	4.5	-	34	43	51	ns
		$C_L = 15\text{pF}$	5	14	-	-	-	ns
Output Enabling Time, $OE_3 \rightarrow Y, \bar{Y}$	t_{PZL}, t_{PZH}	$C_L = 50\text{pF}$	4.5	-	34	43	51	ns
		$C_L = 15\text{pF}$	5	14	-	-	-	ns
Output Transition Time	t_{TLH}, t_{THL}	$C_L = 50\text{pF}$	4.5	-	12	15	18	ns
Input Capacitance	C_{IN}	-	-	-	10	10	10	pF
Three-State Capacitance	C_O	-	-	-	20	20	20	pF
Power Dissipation Capacitance (Notes 4, 5)	C_{PD}	-	5	92	-	-	-	pF

NOTES:

4. C_{PD} is used to determine the dynamic power consumption, per device.
5. $P_D = V_{CC}^2 (C_{PD} + C_L) f_i$ where f_i = Input Frequency, C_L = Output Load Capacitance, V_{CC} = Supply Voltage.

Test Circuits and Waveforms

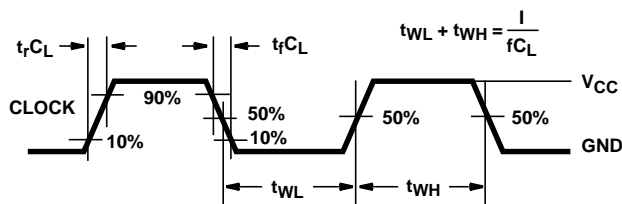

NOTE: Outputs should be switching from 10% V_{CC} to 90% V_{CC} in accordance with device truth table. For f_{MAX} , input duty cycle = 50%.

FIGURE 2. HC CLOCK PULSE RISE AND FALL TIMES AND PULSE WIDTH

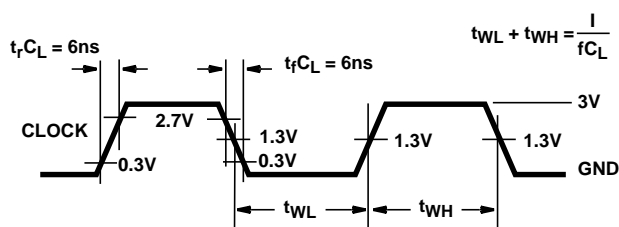

NOTE: Outputs should be switching from 10% V_{CC} to 90% V_{CC} in accordance with device truth table. For f_{MAX} , input duty cycle = 50%.

FIGURE 3. HCT CLOCK PULSE RISE AND FALL TIMES AND PULSE WIDTH

Test Circuits and Waveforms (Continued)

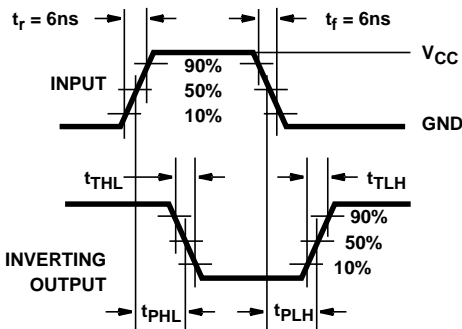

FIGURE 4. HC AND HCT TRANSITION TIMES AND PROPAGATION DELAY TIMES, COMBINATION LOGIC

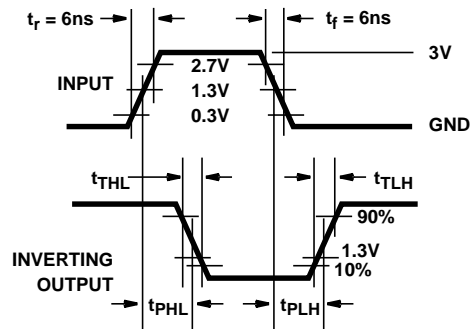

FIGURE 5. HCT TRANSITION TIMES AND PROPAGATION DELAY TIMES, COMBINATION LOGIC

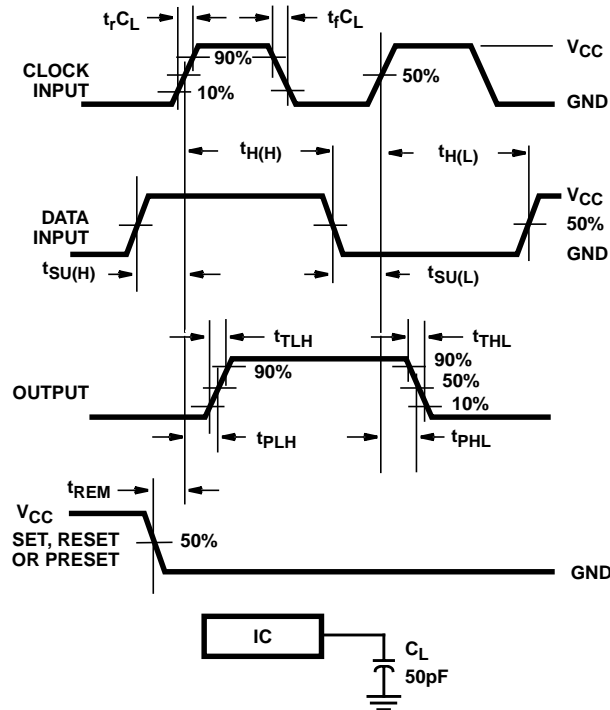

FIGURE 6. HC SETUP TIMES, HOLD TIMES, REMOVAL TIME, AND PROPAGATION DELAY TIMES FOR EDGE TRIGGERED SEQUENTIAL LOGIC CIRCUITS

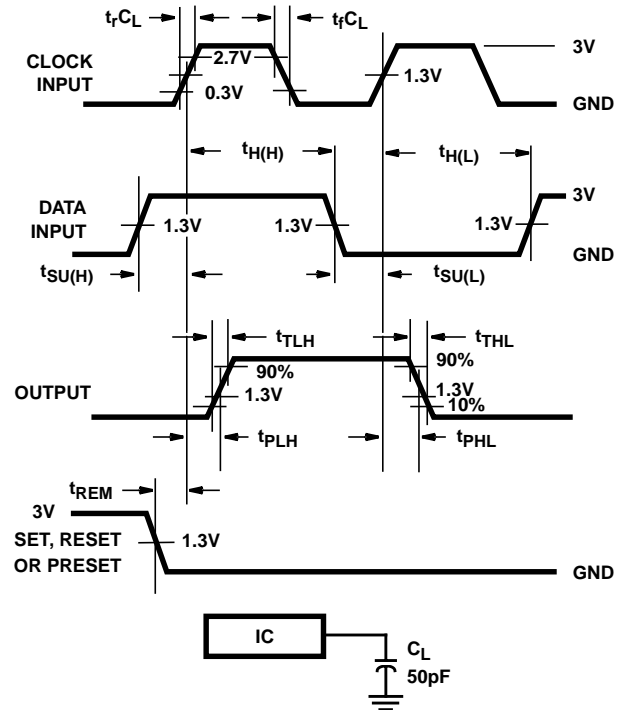

FIGURE 7. HCT SETUP TIMES, HOLD TIMES, REMOVAL TIME, AND PROPAGATION DELAY TIMES FOR EDGE TRIGGERED SEQUENTIAL LOGIC CIRCUITS

Test Circuits and Waveforms (Continued)

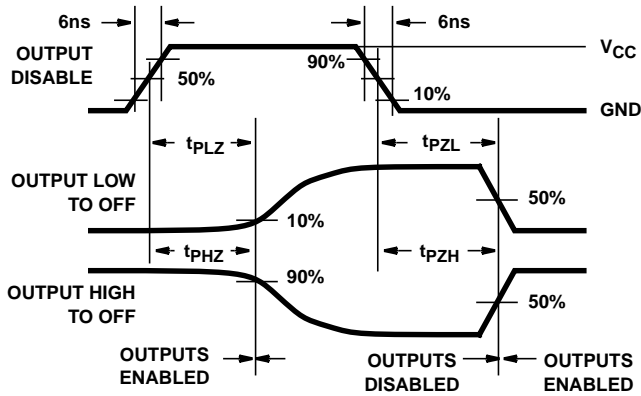

FIGURE 8. HC THREE-STATE PROPAGATION DELAY WAVEFORM

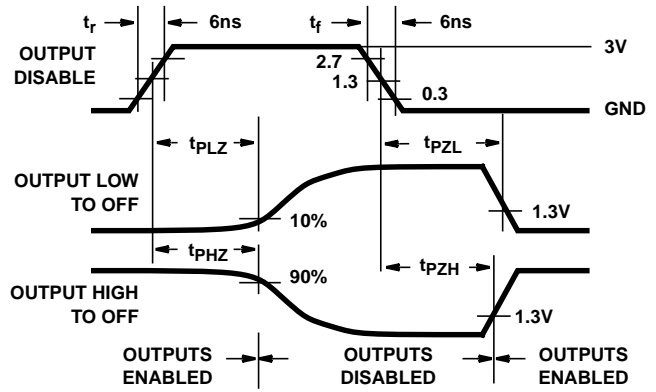
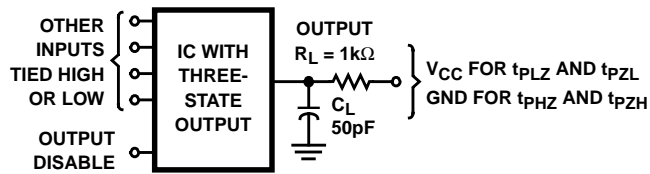

FIGURE 9. HCT THREE-STATE PROPAGATION DELAY WAVEFORM



NOTE: Open drain waveforms t_{PLZ} and t_{PZL} are the same as those for three-state shown on the left. The test circuit is Output $R_L = 1k\Omega$ to V_{CC} , $C_L = 50pF$.

FIGURE 10. HC AND HCT THREE-STATE PROPAGATION DELAY TEST CIRCUIT

PACKAGING INFORMATION

Orderable part number	Status (1)	Material type (2)	Package Pins	Package qty Carrier	RoHS (3)	Lead finish/ Ball material (4)	MSL rating/ Peak reflow (5)	Op temp (°C)	Part marking (6)
CD54HC354F3A	Active	Production	CDIP (J) 20	20 TUBE	No	SNPB	N/A for Pkg Type	-55 to 125	CD54HC354F3A
CD54HC354F3A.A	Active	Production	CDIP (J) 20	20 TUBE	No	SNPB	N/A for Pkg Type	-55 to 125	CD54HC354F3A
CD74HC354E	Active	Production	PDIP (N) 20	20 TUBE	Yes	NIPDAU	N/A for Pkg Type	-55 to 125	CD74HC354E
CD74HC354E.A	Active	Production	PDIP (N) 20	20 TUBE	Yes	NIPDAU	N/A for Pkg Type	-55 to 125	CD74HC354E
CD74HCT354E	Active	Production	PDIP (N) 20	20 TUBE	Yes	NIPDAU	N/A for Pkg Type	-55 to 125	CD74HCT354E
CD74HCT354E.A	Active	Production	PDIP (N) 20	20 TUBE	Yes	NIPDAU	N/A for Pkg Type	-55 to 125	CD74HCT354E

(1) **Status:** For more details on status, see our [product life cycle](#).

(2) **Material type:** When designated, preproduction parts are prototypes/experimental devices, and are not yet approved or released for full production. Testing and final process, including without limitation quality assurance, reliability performance testing, and/or process qualification, may not yet be complete, and this item is subject to further changes or possible discontinuation. If available for ordering, purchases will be subject to an additional waiver at checkout, and are intended for early internal evaluation purposes only. These items are sold without warranties of any kind.

(3) **RoHS values:** Yes, No, RoHS Exempt. See the [TI RoHS Statement](#) for additional information and value definition.

(4) **Lead finish/Ball material:** Parts may have multiple material finish options. Finish options are separated by a vertical ruled line. Lead finish/Ball material values may wrap to two lines if the finish value exceeds the maximum column width.

(5) **MSL rating/Peak reflow:** The moisture sensitivity level ratings and peak solder (reflow) temperatures. In the event that a part has multiple moisture sensitivity ratings, only the lowest level per JEDEC standards is shown. Refer to the shipping label for the actual reflow temperature that will be used to mount the part to the printed circuit board.

(6) **Part marking:** There may be an additional marking, which relates to the logo, the lot trace code information, or the environmental category of the part.

Multiple part markings will be inside parentheses. Only one part marking contained in parentheses and separated by a "~" will appear on a part. If a line is indented then it is a continuation of the previous line and the two combined represent the entire part marking for that device.

Important Information and Disclaimer:The information provided on this page represents TI's knowledge and belief as of the date that it is provided. TI bases its knowledge and belief on information provided by third parties, and makes no representation or warranty as to the accuracy of such information. Efforts are underway to better integrate information from third parties. TI has taken and continues to take reasonable steps to provide representative and accurate information but may not have conducted destructive testing or chemical analysis on incoming materials and chemicals. TI and TI suppliers consider certain information to be proprietary, and thus CAS numbers and other limited information may not be available for release.

In no event shall TI's liability arising out of such information exceed the total purchase price of the TI part(s) at issue in this document sold by TI to Customer on an annual basis.

OTHER QUALIFIED VERSIONS OF CD54HC354, CD74HC354 :

- Catalog : [CD74HC354](#)
- Military : [CD54HC354](#)

NOTE: Qualified Version Definitions:

- Catalog - TI's standard catalog product
- Military - QML certified for Military and Defense Applications

TUBE

*All dimensions are nominal

Device	Package Name	Package Type	Pins	SPQ	L (mm)	W (mm)	T (μm)	B (mm)
CD74HC354E	N	PDIP	20	20	506	13.97	11230	4.32
CD74HC354E.A	N	PDIP	20	20	506	13.97	11230	4.32
CD74HCT354E	N	PDIP	20	20	506	13.97	11230	4.32
CD74HCT354E.A	N	PDIP	20	20	506	13.97	11230	4.32

J (R-GDIP-T**)

14 LEADS SHOWN

CERAMIC DUAL IN-LINE PACKAGE



DIM \ PINS **	14	16	18	20
A	0.300 (7,62) BSC	0.300 (7,62) BSC	0.300 (7,62) BSC	0.300 (7,62) BSC
B MAX	0.785 (19,94)	.840 (21,34)	0.960 (24,38)	1.060 (26,92)
B MIN	—	—	—	—
C MAX	0.300 (7,62)	0.300 (7,62)	0.310 (7,87)	0.300 (7,62)
C MIN	0.245 (6,22)	0.245 (6,22)	0.220 (5,59)	0.245 (6,22)



4040083/F 03/03

- NOTES:
- All linear dimensions are in inches (millimeters).
 - This drawing is subject to change without notice.
 - This package is hermetically sealed with a ceramic lid using glass frit.
 - Index point is provided on cap for terminal identification only on press ceramic glass frit seal only.
 - Falls within MIL STD 1835 GDIP1-T14, GDIP1-T16, GDIP1-T18 and GDIP1-T20.

N (R-PDIP-T**)

PLASTIC DUAL-IN-LINE PACKAGE

16 PINS SHOWN



- NOTES:
- A. All linear dimensions are in inches (millimeters).
 - B. This drawing is subject to change without notice.
 - Falls within JEDEC MS-001, except 18 and 20 pin minimum body length (Dim A).
 - The 20 pin end lead shoulder width is a vendor option, either half or full width.

IMPORTANT NOTICE AND DISCLAIMER

TI PROVIDES TECHNICAL AND RELIABILITY DATA (INCLUDING DATASHEETS), DESIGN RESOURCES (INCLUDING REFERENCE DESIGNS), APPLICATION OR OTHER DESIGN ADVICE, WEB TOOLS, SAFETY INFORMATION, AND OTHER RESOURCES "AS IS" AND WITH ALL FAULTS, AND DISCLAIMS ALL WARRANTIES, EXPRESS AND IMPLIED, INCLUDING WITHOUT LIMITATION ANY IMPLIED WARRANTIES OF MERCHANTABILITY, FITNESS FOR A PARTICULAR PURPOSE OR NON-INFRINGEMENT OF THIRD PARTY INTELLECTUAL PROPERTY RIGHTS.

These resources are intended for skilled developers designing with TI products. You are solely responsible for (1) selecting the appropriate TI products for your application, (2) designing, validating and testing your application, and (3) ensuring your application meets applicable standards, and any other safety, security, regulatory or other requirements.

These resources are subject to change without notice. TI grants you permission to use these resources only for development of an application that uses the TI products described in the resource. Other reproduction and display of these resources is prohibited. No license is granted to any other TI intellectual property right or to any third party intellectual property right. TI disclaims responsibility for, and you fully indemnify TI and its representatives against any claims, damages, costs, losses, and liabilities arising out of your use of these resources.

TI's products are provided subject to [TI's Terms of Sale](#), [TI's General Quality Guidelines](#), or other applicable terms available either on [ti.com](#) or provided in conjunction with such TI products. TI's provision of these resources does not expand or otherwise alter TI's applicable warranties or warranty disclaimers for TI products. Unless TI explicitly designates a product as custom or customer-specified, TI products are standard, catalog, general purpose devices.

TI objects to and rejects any additional or different terms you may propose.

Copyright © 2025, Texas Instruments Incorporated

Last updated 10/2025