

CD74HC4538-Q1 Automotive High-Speed CMOS Logic Dual Retriggerable Precision Monostable Multivibrator

1 Features

- Qualified for automotive applications
- Qualified for automotive applications retriggerable/resettable capability
- Trigger and reset propagation delays independent of R_X , C_X
- Triggering from the leading or trailing edge
- Q and \bar{Q} buffered outputs available
- Separate resets
- Wide range of output pulse widths
- Schmitt-Trigger input on A and \bar{B} inputs
- Retrigger time is independent of C_X
- Fanout (over temperature range)
 - Standard outputs 10 LSTTL loads
 - Bus driver outputs 15 LSTTL loads

- Balanced propagation delay and transition times
- Significant power reduction compared to LSTTL logic ICs
- V_{CC} voltage = 2V to 6V
- High noise immunity N_{IL} or N_{IH} = 30% of V_{CC} , V_{CC} = 5V

2 Description

The CD74HC4538 is a dual retriggerable/resettable precision monostable multivibrator for fixed-voltage timing applications.

Package Information

PART NUMBER	PACKAGE ⁽¹⁾	PACKAGE SIZE ⁽²⁾	BODY SIZE
CD74HC4538-Q1	D (SOIC, 16)	9.9mm × 6mm	9.9mm × 3.90mm
	PW (TSSOP, 16)	5mm × 6.4mm	5.00mm × 4.40mm

- (1) For more information, see [Mechanical, Packaging, and Orderable Information](#).
- (2) The package size (length × width) is a nominal value and includes pins, where applicable.
- (3) The body size (length × width) is a nominal value and does not include pins.



Table of Contents

1 Features	1	6.2 Functional Block Diagram.....	9
2 Description	1	6.3 Device Functional Modes.....	10
3 Pin Configuration and Functions	3	7 Application and Implementation	11
4 Specifications	4	7.1 Typical Application.....	11
4.1 Absolute Maximum Ratings.....	4	7.2 Power Supply Recommendations.....	11
4.2 ESD Ratings.....	4	7.3 Layout.....	11
4.3 Recommended Operating Conditions.....	4	8 Device and Documentation Support	13
4.4 Thermal Information.....	5	8.1 Documentation Support (Analog).....	13
4.5 Electrical Characteristics.....	5	8.2 Receiving Notification of Documentation Updates....	13
4.6 Timing Requirements.....	5	8.3 Support Resources.....	13
4.7 Switching Characteristics.....	6	8.4 Trademarks.....	13
4.8 Operating Characteristics.....	6	8.5 Electrostatic Discharge Caution.....	13
4.9 Typical Characteristics.....	6	8.6 Glossary.....	13
5 Parameter Measurement Information	8	9 Revision History	13
6 Detailed Description	9	10 Mechanical, Packaging, and Orderable Information	13
6.1 Overview.....	9		

3 Pin Configuration and Functions

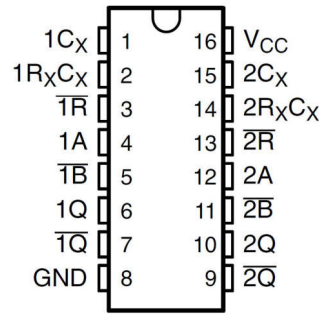

Figure 3-1. D or PW Package; 16-Pin SOIC or TSSOP (Top View)

Table 3-1. Pin Functions

PIN		TYPE	DESCRIPTION
NAME	NO.		
1Cx	1	—	Connects to external capacitor
1RxCx	2	—	Connects to external capacitor and resistor
1 \overline{R}	3	—	Connects to external resistor
1A	4	I	Ch1 Rising edge input
1B	5	I	Ch1 Falling edge input
1Q	6	O	Ch1 Output
$\overline{1Q}$	7	O	Ch1 Inverted Output
GND	8	—	Ground
$\overline{2Q}$	9	O	Ch2 Inverted Output
2Q	10	O	Ch2 Output
2B	11	I	Ch2 Falling edge input
2A	12	I	Ch2 Rising edge input
2R	13	—	Connects to external resistor
2RxCx	14	—	Connects to external capacitor and resistor
2Cx	15	—	Connects to external capacitor
V _{CC}	16	—	Power Pin

4 Specifications

4.1 Absolute Maximum Ratings

over operating free-air temperature (unless otherwise noted)⁽¹⁾

			MIN	MAX	UNIT
V _{CC}	Supply voltage ⁽²⁾		-0.5	7	V
I _{IK}	Input clamp current	(V _I < -0.5V or V _I > V _{CC} + 0.5V)		±20	mA
I _{OK}	Output clamp current	(V _O < -0.5V or V _O > V _{CC} + 0.5V)		±20	mA
I _O	Switch current per output pin	(V _O > -0.5V or V _O < V _{CC} + 0.5V)		±25	mA
	Continuous current through V _{CC} or GND			±50	mA
T _J	Maximum junction temperature			150	°C
T _{stg}	Storage temperature range		-65	150	°C

(1) Stresses beyond those listed under "absolute maximum ratings" may cause permanent damage to the device. These are stress ratings only, and functional operation of the device at these or any other conditions beyond those indicated under "recommended operating conditions" is not implied. Exposure to absolute-maximum-rated conditions for extended periods may affect device reliability.

(2) All voltages are referenced to GND, unless otherwise specified.

4.2 ESD Ratings

			VALUE	UNIT
V _(ESD)	Electrostatic discharge	Human body model (HBM), per AEC Q100-002 ⁽¹⁾	±1500	V
		Charged device model (CDM), per AEC Q100-011	±250	

(1) AEC Q100-002 indicates that HBM stressing must be in accordance with the ANSI/ESDA/JEDEC JS-001 specification.

4.3 Recommended Operating Conditions

over operating free-air temperature (unless otherwise noted)

			MIN	MAX	UNIT
V _{CC}	Supply voltage		2	6	V
V _{IH}	High-level input voltage	V _{CC} = 2V	1.5		V
		V _{CC} = 4.5V	3.15		
		V _{CC} = 6V	4.2		
V _{IL}	Low-level input voltage	V _{CC} = 2V		0.5	V
		V _{CC} = 4.5V		1.35	
		V _{CC} = 6V		1.8	
V _I	Input voltage		0	V _{CC}	V
V _O	Output voltage		0	V _{CC}	V
t _t	Reset input	V _{CC} = 2V	0	1000	ns
		V _{CC} = 4.5V	0	500	
		V _{CC} = 6V	0	400	
	Trigger inputs A or B	V _{CC} = 2V	0	Unlimited	
		V _{CC} = 4.5V	0	Unlimited	
		V _{CC} = 6V	0	Unlimited	
R _X	External timing resistor ⁽¹⁾		5		kΩ
C _X	External timing capacitor ⁽¹⁾		0		F
T _A	Operating free-air temperature		-40	125	°C

(1) All unused inputs of the device must be held at V_{CC} or GND to ensure proper device operation. Refer to the TI application report, *Implications of Slow or Floating CMOS Inputs*, literature number SCBA004.

4.4 Thermal Information

THERMAL METRIC ⁽¹⁾		CD74HC4538-Q1		UNIT
		D	PW	
		16 PINS		
$R_{\theta JA}$	Junction-to-ambient thermal resistance	73	108	°C/W

(1) For more information about traditional and new thermal metrics, see the *IC Package Thermal Metrics* application report ([SPRA953](#)).

4.5 Electrical Characteristics

over recommended operating free-air temperature range (unless otherwise noted)

PARAMETER	TEST CONDITIONS	$I_{O}mA$	V_{CC}	$T_A = 25^\circ C$		$T_A = -40^\circ C \text{ TO } 85^\circ C$		$T_A = -40^\circ C \text{ TO } 125^\circ C$		UNIT
				MIN	MAX	MIN	MAX	MIN	MAX	
V_{OH}	$V_I = V_{IH}$ or V_{IL}	CMOS loads	2 V	1.9	1.9	1.9	V			
			4.5 V	4.4	4.4					
			6 V	5.9	5.9					
		TTL loads	-4	4.5 V	3.98	3.84	3.7			
-5.2	6 V		5.48	5.34	5.2					
V_{OL}	$V_I = V_{IH}$ or V_{IL}	CMOS loads	2 V	0.1	0.1	0.1	V			
			4.5 V	0.1	0.1					
			6 V	0.1	0.1					
		TTL loads	4	4.5 V	0.26	0.33	0.4			
5.2	6 V		0.26	0.33	0.4					
I_I	$V_I = V_{CC}$ or GND	A, \bar{B} , R	6 V	± 1	± 1	± 1	μA			
		$R_X C_X$ ⁽¹⁾	6 V	± 0.05	± 0.05	± 0.05				
I_{CC}	$V_I = V_{CC}$ or GND	Quiescent	0	6 V	8	80	160	μA		
		Active, Q = high, Pins 2 and 14 at $V_{CC}/4$	0	6 V	0.6	0.8	1	mA		
C_{IN}	$C_L = 50$ pF			10	10	10	pF			

(1) When testing I_{IL} , the Q output must be high. If Q is low (device not triggered), the pullup P device is ON and the low-resistance path from V_{DD} to the test pin causes a current far exceeding the specification.

4.6 Timing Requirements

over recommended operating free-air temperature range, $V_{CC} = 5 V \pm 0.5 V$ (unless otherwise noted) (see [Load Circuit and Voltage Waveforms](#))

PARAMETER	V_{CC}	$T_A = 25^\circ C$			$T_A = -40^\circ C \text{ TO } 85^\circ C$		$T_A = -40^\circ C \text{ TO } 125^\circ C$		UNIT
		MIN	TYP	MAX	MIN	MAX	MIN	MAX	
t_w Input pulse width	2 V	80			100		120	ns	
	4.5 V	16			20		24		
	6 V	14			17		20		
t_{su} Reset setup time	2 V	5			5		5	ns	
	4.5 V	5			5		5		
	6 V	5			5		5		
t_{rr} Retrigger time	5 V		175					ns	
Output pulse-width match, same package			± 1					%	

4.7 Switching Characteristics

over recommended operating free-air temperature range, $V_{CC} = 5 V \pm 0.5 V$ (unless otherwise noted) (see [Load Circuit and Voltage Waveforms](#))

PARAMETER	FROM (INPUT)	TO (OUTPUT)	LOAD CAPACITANCE	V_{CC}	$T_A = 25^\circ C$			$T_A = -40^\circ C \text{ TO } 85^\circ C$		$T_A = -40^\circ C \text{ TO } 125^\circ C$		UNIT
					MIN	TYP	MAX	MIN	MAX	MIN	MAX	
t_{pd}	A, \bar{B}	Q or \bar{Q}	$C_L = 50 \text{ pF}$	2 V		250		315		375	ns	
				4.5 V		50		63		75		
				6 V		43		54		64		
	R	Q or \bar{Q}	$C_L = 50 \text{ pF}$	2 V		250		315		375		
				4.5 V		50		63		75		
				6 V		43		54		64		
t_t			$C_L = 50 \text{ pF}$	2 V		75		95		110	ns	
				4.5 V		15		19		22		
				6 V		13		16		19		
$\tau^{(1)}$			$C_L = 50 \text{ pF}$	3 V	0.64	0.78	0.612	0.812	0.605	0.819	ms	
				5 V	0.63	0.77	0.602	0.798	0.595	0.805		

(1) Output pulse width with $R_X = 10 \text{ k}\Omega$ and $C_X = 0.1 \mu\text{F}$

4.8 Operating Characteristics

$V_{CC} = 5 V$, $T_A = 25^\circ C$, input $t_r, t_f = 6 \text{ ns}$, $C_L = 15 \text{ pF}$

PARAMETER		TYP	UNIT
C_{pd}	Power dissipation capacitance	136	pF

Note

- C_{pd} is used to determine the dynamic power consumption, per one shot.
- $P_D = (C_{pd} + C_X) V_{CC} 2 f_i \Sigma(C_L V_{CC} 2 f_o)$
- f_i = input frequency
- f_o = output frequency
- C_L = output load capacitance
- C_X = external capacitance
- V_{CC} = supply voltage, assuming $f_i \ll 1/\tau$

4.9 Typical Characteristics

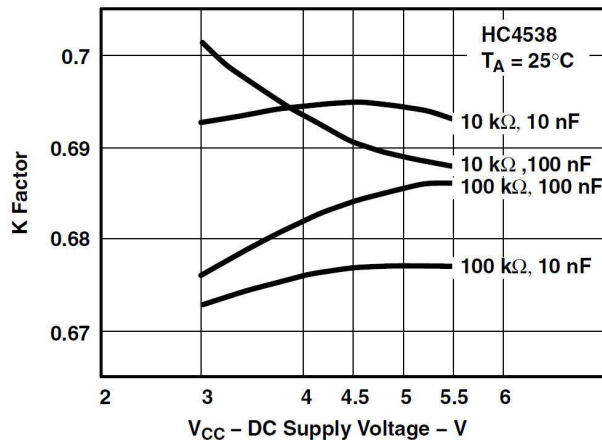

Figure 4-1. K Factor vs DC Supply Voltage

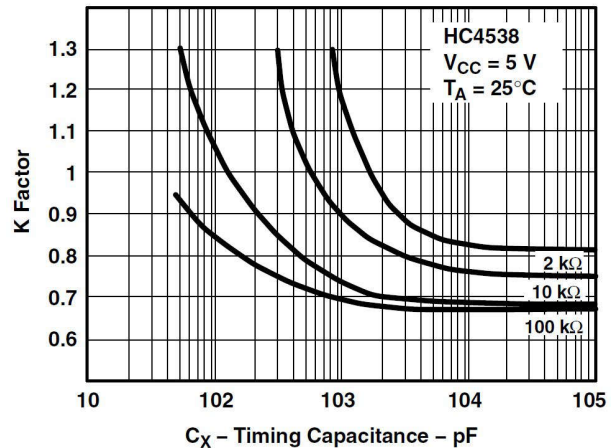

Figure 4-2. K Factor vs C_X

4.9 Typical Characteristics (continued)

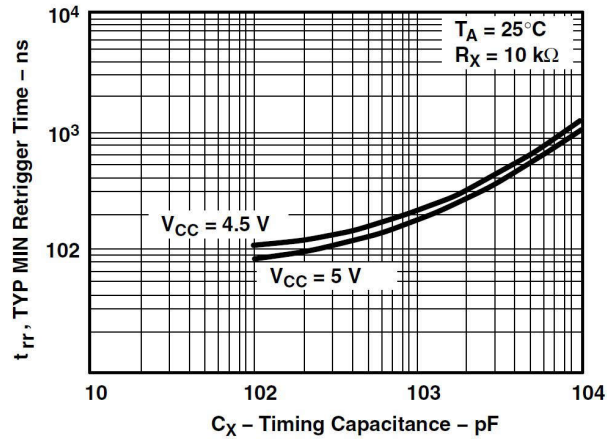
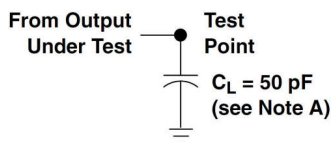

Figure 4-3. Minimum Retrigger Time vs Timing Capacitance

5 Parameter Measurement Information

Load Circuit and Voltage Waveforms



LOAD CIRCUIT
 Figure 5-1. Load Circuit

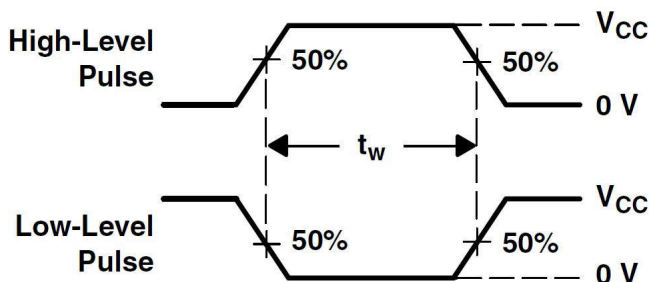

Figure 5-2. Voltage Waveforms Pulse Durations

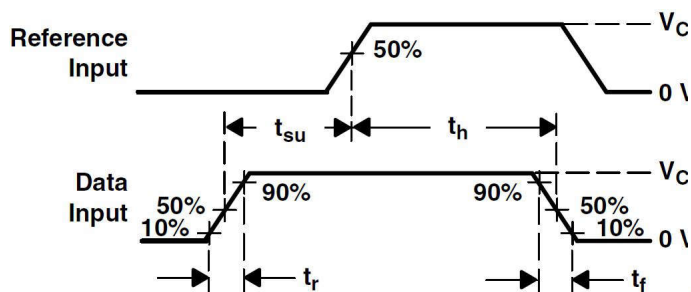

Figure 5-3. Voltage Waveforms Setup and Hold and Input Rise and Fall Times

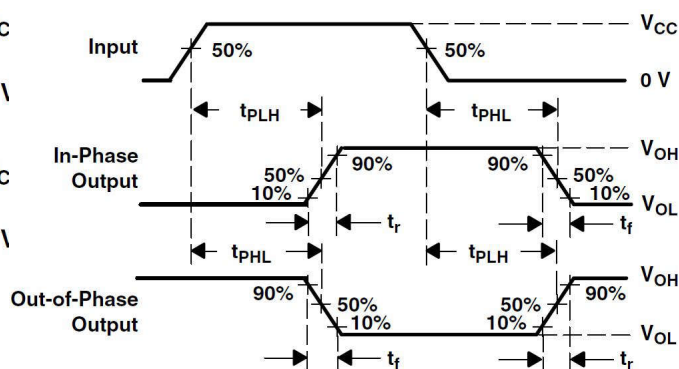

Figure 5-4. Voltage Waveforms Propagation Delay and Output Transition Times

Note

- C_L includes probe and test-fixture capacitance.
- Phase relationships between waveforms were chosen arbitrarily. All input pulses are supplied by generators having the following characteristics: $PRR \leq 1 \text{ MHz}$, $Z_O = 50 \Omega$, $t_r = 6 \text{ ns}$, $t_f = 6 \text{ ns}$.
- For clock inputs, f_{max} is measured when the input duty cycle is 50%.
- The outputs are measured one at a time, with one input transition per measurement.
- t_{PLH} and t_{PHL} are the same as t_{pd} .

6 Detailed Description

6.1 Overview

An external resistor (R_X) and external capacitor (C_X) control the timing and accuracy for the circuit. Adjustment of R_X and C_X provides a wide range of output pulse widths from the Q and \bar{Q} terminals. The propagation delay from trigger input-to-output transition and the propagation delay from reset input-to-output transition are independent of R_X and C_X .

Leading-edge triggering (A) and trailing-edge triggering (\bar{B}) inputs are provided for triggering from either edge of the input pulse. An unused A input should be tied to GND and an unused \bar{B} input should be tied to V_{CC} . On power up, the IC is reset. Unused resets and sections must be terminated. In normal operation, the circuit retriggers on the application of each new trigger pulse. To operate in the nontriggerable mode, \bar{Q} is connected to \bar{B} when leading-edge triggering (A) is used, or Q is connected to A when trailing-edge triggering (\bar{B}) is used. The period (τ) can be calculated from $\tau = (0.7) R_X C_X$; R_{MIN} is 5 k Ω . C_{MIN} is 0 pF.

6.2 Functional Block Diagram

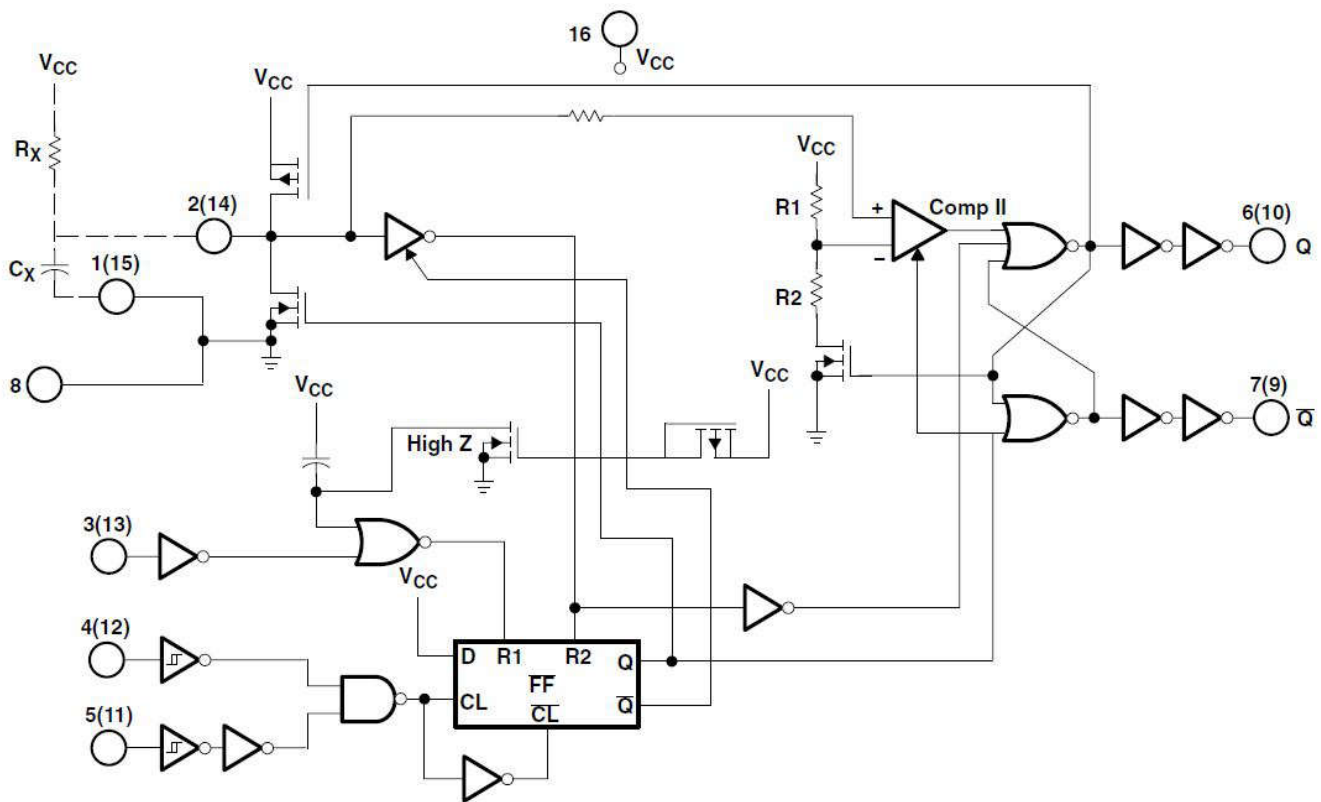

Figure 6-1. Logic Diagram (Positive Logic)

6.3 Device Functional Modes

Table 6-1. Function Table





INPUTS			OUTPUTS	
\bar{R}	A	\bar{B}	Q	\bar{Q}
L	X	X	L	H
X	H	X	L	H
X	X	L	L	H
H	L	↓		
H	↑	H		

Table 6-2. Functional Terminal Connections

FUNCTION	V_{CC} TO TERMINAL NUMBER		GND TO TERMINAL NUMBER		INPUT PULSE TO TERMINAL NUMBER		OTHER CONNECTIONS	
	MONO ⁽¹⁾	MONO ⁽²⁾	MONO ⁽¹⁾	MONO ⁽²⁾	MONO ⁽¹⁾	MONO ⁽²⁾	MONO ⁽¹⁾	MONO ⁽²⁾
Leading-edge trigger/retriggerable	3, 5	11, 13			4	12		
Leading-edge trigger/nonretriggerable	3	13			4	12	5-7	11-9
Trailing-edge trigger/retriggerable	3	13	4	12	5	11		
Trailing-edge trigger/nonretriggerable	3	13			5	11	4-6	12-10

- (1) A retriggerable one-shot multivibrator has an output pulse width that is extended one full time period (T) after application of the last trigger pulse.
- (2) A nonretriggerable one-shot multivibrator has a time period (T) referenced from the application of the first trigger pulse.

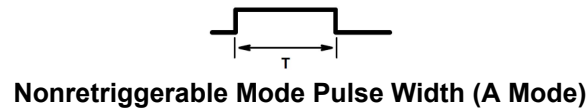
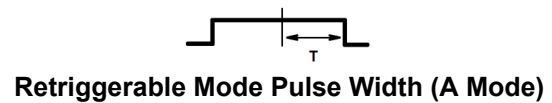

7 Application and Implementation

Note

Information in the following applications sections is not part of the TI component specification, and TI does not warrant its accuracy or completeness. TI's customers are responsible for determining suitability of components for their purposes, as well as validating and testing their design implementation to confirm system functionality.

7.1 Typical Application

Power-Down Mode

During a rapid power-down condition (as would occur with a power-supply short circuit with a poorly filtered power supply), the energy stored in C_X could discharge into pin 2 or pin 14. To avoid possible device damage in this mode when C_X is $\geq 0.5 \mu\text{F}$, a protection diode with a 1-A rating or higher (1N5395 or equivalent) and a separate ground return for C_X should be provided. [Rapid-Power-Down Protection Circuit](#)

An alternate protection method is shown in [Alternative Rapid-Power-Down Protection Circuit](#), where a 51- Ω current-limiting resistor is inserted in series with C_X . Note that a small pulse-duration decrease occurs, however, and R_X must be increased appropriately to obtain the originally desired pulse duration.

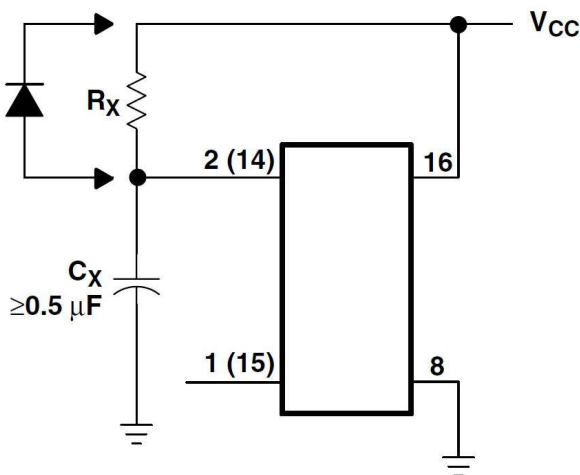

Figure 7-1. Rapid-Power-Down Protection Circuit

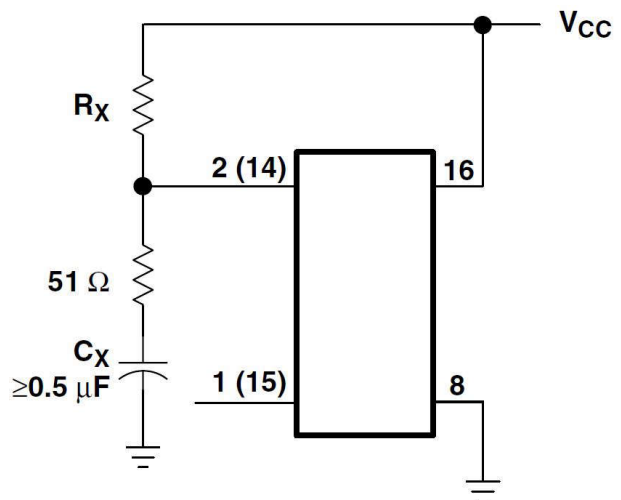

Figure 7-2. Alternative Rapid-Power-Down Protection Circuit

7.2 Power Supply Recommendations

The power supply can be any voltage between the minimum and maximum supply voltage rating located in the *Recommended Operating Conditions*. Each V_{CC} terminal should have a good bypass capacitor to prevent power disturbance. A 0.1- μF capacitor is recommended for this device. It is acceptable to parallel multiple bypass capacitors to reject different frequencies of noise. The 0.1- μF and 1- μF capacitors are commonly used in parallel. The bypass capacitor should be installed as close to the power terminal as possible for best results, as shown in the following layout example.

7.3 Layout

7.3.1 Layout Guidelines

When using multiple bit logic devices, inputs should not float. In many cases, functions or parts of functions of digital logic devices are unused. Some examples are when only two inputs of a triple-input AND gate are used,

or when only 3 of the 4-buffer gates are used. Such input pins should not be left unconnected because the undefined voltages at the outside connections result in undefined operational states.

Specified are rules that must be observed under all circumstances. All unused inputs of digital logic devices must be connected to a high or low bias to prevent them from floating. The logic level that should be applied to any particular unused input depends on the function of the device. Generally they will be tied to GND or V_{CC} , whichever makes more sense or is more convenient. It is acceptable to float outputs unless the part is a transceiver. If the transceiver has an output enable pin, it will disable the outputs section of the part when asserted. This will not disable the input section of the I/Os so they also cannot float when disabled.

8 Device and Documentation Support

8.1 Documentation Support (Analog)

8.1.1 Related Links

The table below lists quick access links. Categories include technical documents, support and community resources, tools and software, and quick access to sample or buy.

Table 8-1. Related Links

PARTS	PRODUCT FOLDER	SAMPLE & BUY	TECHNICAL DOCUMENTS	TOOLS & SOFTWARE	SUPPORT & COMMUNITY
CD74HC4538-Q1	Click here	Click here	Click here	Click here	Click here

8.2 Receiving Notification of Documentation Updates

To receive notification of documentation updates, navigate to the device product folder on ti.com. Click on *Notifications* to register and receive a weekly digest of any product information that has changed. For change details, review the revision history included in any revised document.

8.3 Support Resources

[TI E2E™ support forums](#) are an engineer's go-to source for fast, verified answers and design help — straight from the experts. Search existing answers or ask your own question to get the quick design help you need.

Linked content is provided "AS IS" by the respective contributors. They do not constitute TI specifications and do not necessarily reflect TI's views; see TI's [Terms of Use](#).

8.4 Trademarks

TI E2E™ is a trademark of Texas Instruments.
All trademarks are the property of their respective owners.

8.5 Electrostatic Discharge Caution



This integrated circuit can be damaged by ESD. Texas Instruments recommends that all integrated circuits be handled with appropriate precautions. Failure to observe proper handling and installation procedures can cause damage.

ESD damage can range from subtle performance degradation to complete device failure. Precision integrated circuits may be more susceptible to damage because very small parametric changes could cause the device not to meet its published specifications.

8.6 Glossary

[TI Glossary](#) This glossary lists and explains terms, acronyms, and definitions.

9 Revision History

Changes from Revision A (April 2008) to Revision B (August 2024)	Page
• Added <i>Package Information</i> table, <i>Pin Functions</i> table, <i>ESD Ratings</i> table, <i>Thermal Information</i> table, <i>Device Functional Modes</i> , Application and Implementation section, <i>Device and Documentation Support</i> section, and <i>Mechanical, Packaging, and Orderable Information</i> section	1

10 Mechanical, Packaging, and Orderable Information

The following pages include mechanical, packaging, and orderable information. This information is the most current data available for the designated devices. This data is subject to change without notice and revision of this document. For browser-based versions of this data sheet, refer to the left-hand navigation.

PACKAGING INFORMATION

Orderable part number	Status (1)	Material type (2)	Package Pins	Package qty Carrier	RoHS (3)	Lead finish/ Ball material (4)	MSL rating/ Peak reflow (5)	Op temp (°C)	Part marking (6)
CD74HC4538QM96G4Q1	NRND	Production	SOIC (D) 16	2500 LARGE T&R	Yes	NIPDAU	Level-1-260C-UNLIM	-40 to 125	HC4538M
CD74HC4538QM96G4Q1.A	NRND	Production	SOIC (D) 16	2500 LARGE T&R	Yes	NIPDAU	Level-1-260C-UNLIM	-40 to 125	HC4538M
CD74HC4538QPWRG4Q1	Active	Production	TSSOP (PW) 16	2000 LARGE T&R	Yes	NIPDAU	Level-1-260C-UNLIM	-40 to 125	HC4538M
CD74HC4538QPWRG4Q1.A	Active	Production	TSSOP (PW) 16	2000 LARGE T&R	Yes	NIPDAU	Level-1-260C-UNLIM	-40 to 125	HC4538M
CD74HC4538QPWRQ1	Active	Production	TSSOP (PW) 16	2000 LARGE T&R	Yes	NIPDAU	Level-1-260C-UNLIM	-40 to 125	HC4538M
CD74HC4538QPWRQ1.A	Active	Production	TSSOP (PW) 16	2000 LARGE T&R	Yes	NIPDAU	Level-1-260C-UNLIM	-40 to 125	HC4538M

(1) **Status:** For more details on status, see our [product life cycle](#).

(2) **Material type:** When designated, preproduction parts are prototypes/experimental devices, and are not yet approved or released for full production. Testing and final process, including without limitation quality assurance, reliability performance testing, and/or process qualification, may not yet be complete, and this item is subject to further changes or possible discontinuation. If available for ordering, purchases will be subject to an additional waiver at checkout, and are intended for early internal evaluation purposes only. These items are sold without warranties of any kind.

(3) **RoHS values:** Yes, No, RoHS Exempt. See the [TI RoHS Statement](#) for additional information and value definition.

(4) **Lead finish/Ball material:** Parts may have multiple material finish options. Finish options are separated by a vertical ruled line. Lead finish/Ball material values may wrap to two lines if the finish value exceeds the maximum column width.

(5) **MSL rating/Peak reflow:** The moisture sensitivity level ratings and peak solder (reflow) temperatures. In the event that a part has multiple moisture sensitivity ratings, only the lowest level per JEDEC standards is shown. Refer to the shipping label for the actual reflow temperature that will be used to mount the part to the printed circuit board.

(6) **Part marking:** There may be an additional marking, which relates to the logo, the lot trace code information, or the environmental category of the part.

Multiple part markings will be inside parentheses. Only one part marking contained in parentheses and separated by a "~" will appear on a part. If a line is indented then it is a continuation of the previous line and the two combined represent the entire part marking for that device.

Important Information and Disclaimer: The information provided on this page represents TI's knowledge and belief as of the date that it is provided. TI bases its knowledge and belief on information provided by third parties, and makes no representation or warranty as to the accuracy of such information. Efforts are underway to better integrate information from third parties. TI has taken and continues to take reasonable steps to provide representative and accurate information but may not have conducted destructive testing or chemical analysis on incoming materials and chemicals. TI and TI suppliers consider certain information to be proprietary, and thus CAS numbers and other limited information may not be available for release.

In no event shall TI's liability arising out of such information exceed the total purchase price of the TI part(s) at issue in this document sold by TI to Customer on an annual basis.

OTHER QUALIFIED VERSIONS OF CD74HC4538-Q1 :

- Catalog : [CD74HC4538](#)
- Military : [CD54HC4538](#)

NOTE: Qualified Version Definitions:

- Catalog - TI's standard catalog product
- Military - QML certified for Military and Defense Applications

TAPE AND REEL INFORMATION

QUADRANT ASSIGNMENTS FOR PIN 1 ORIENTATION IN TAPE



*All dimensions are nominal

Device	Package Type	Package Drawing	Pins	SPQ	Reel Diameter (mm)	Reel Width W1 (mm)	A0 (mm)	B0 (mm)	K0 (mm)	P1 (mm)	W (mm)	Pin1 Quadrant
CD74HC4538QPWRG4Q1	TSSOP	PW	16	2000	330.0	12.4	6.9	5.6	1.6	8.0	12.0	Q1

TAPE AND REEL BOX DIMENSIONS

*All dimensions are nominal

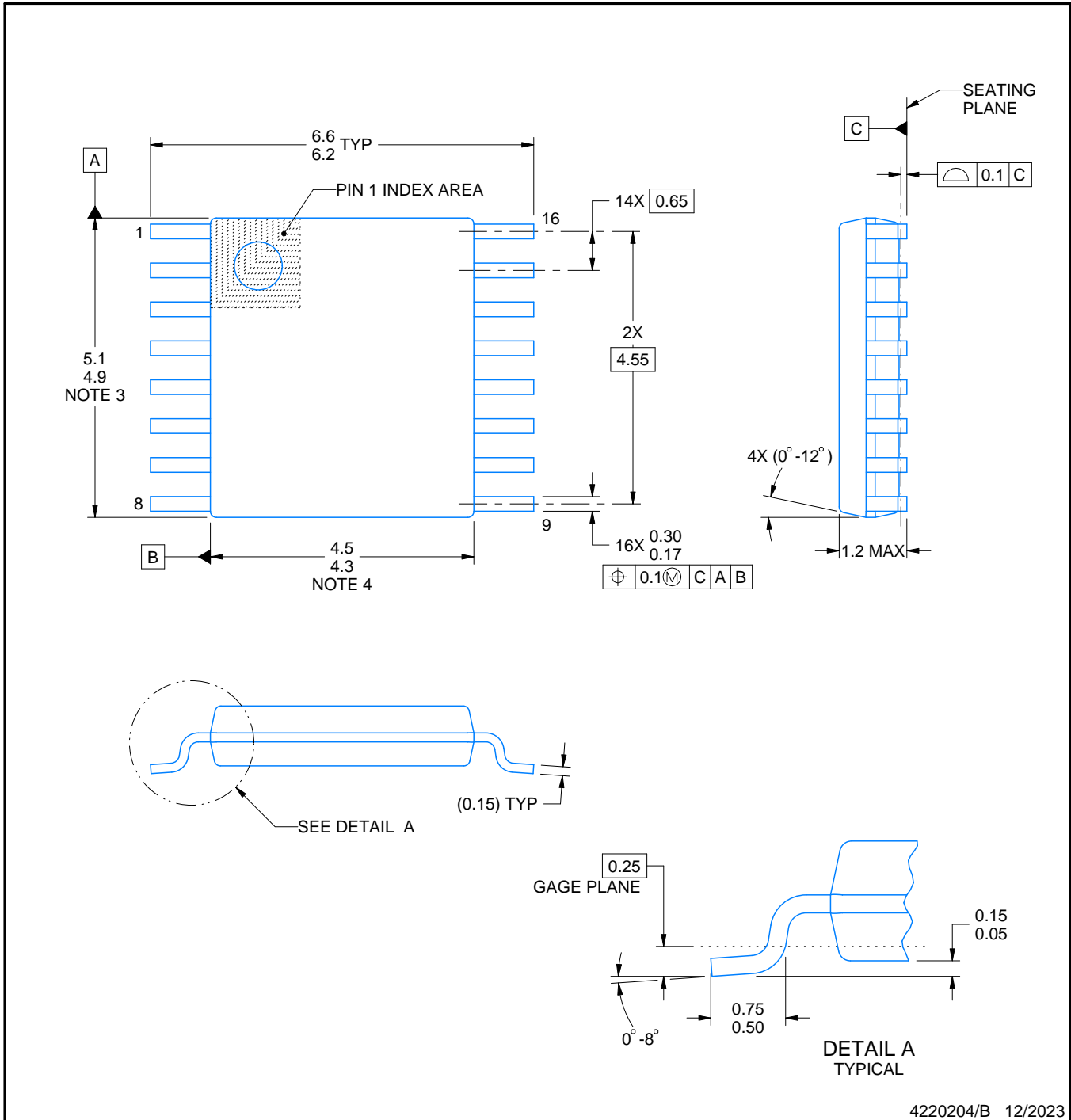
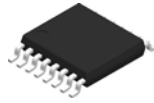
Device	Package Type	Package Drawing	Pins	SPQ	Length (mm)	Width (mm)	Height (mm)
CD74HC4538QPWRG4Q1	TSSOP	PW	16	2000	353.0	353.0	32.0



4220204/B 12/2023

NOTES:

1. All linear dimensions are in millimeters. Any dimensions in parenthesis are for reference only. Dimensioning and tolerancing per ASME Y14.5M.
2. This drawing is subject to change without notice.
3. This dimension does not include mold flash, protrusions, or gate burrs. Mold flash, protrusions, or gate burrs shall not exceed 0.15 mm per side.
4. This dimension does not include interlead flash. Interlead flash shall not exceed 0.25 mm per side.
5. Reference JEDEC registration MO-153.

EXAMPLE BOARD LAYOUT

PW0016A

TSSOP - 1.2 mm max height

SMALL OUTLINE PACKAGE

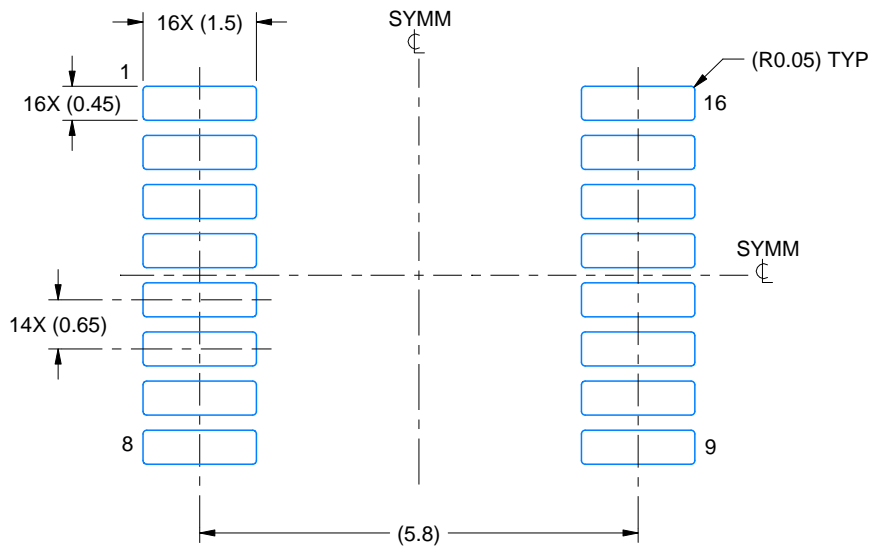

LAND PATTERN EXAMPLE
EXPOSED METAL SHOWN
SCALE: 10X

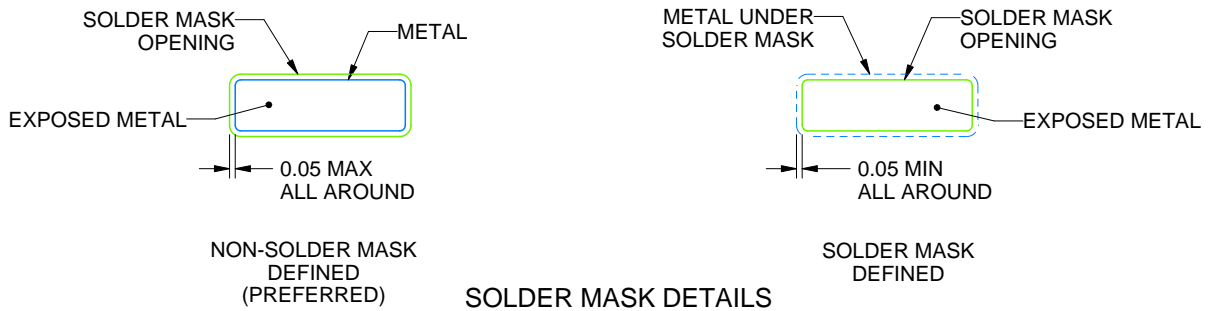

4220204/B 12/2023

NOTES: (continued)

- 6. Publication IPC-7351 may have alternate designs.
- 7. Solder mask tolerances between and around signal pads can vary based on board fabrication site.

EXAMPLE STENCIL DESIGN

PW0016A

TSSOP - 1.2 mm max height

SMALL OUTLINE PACKAGE

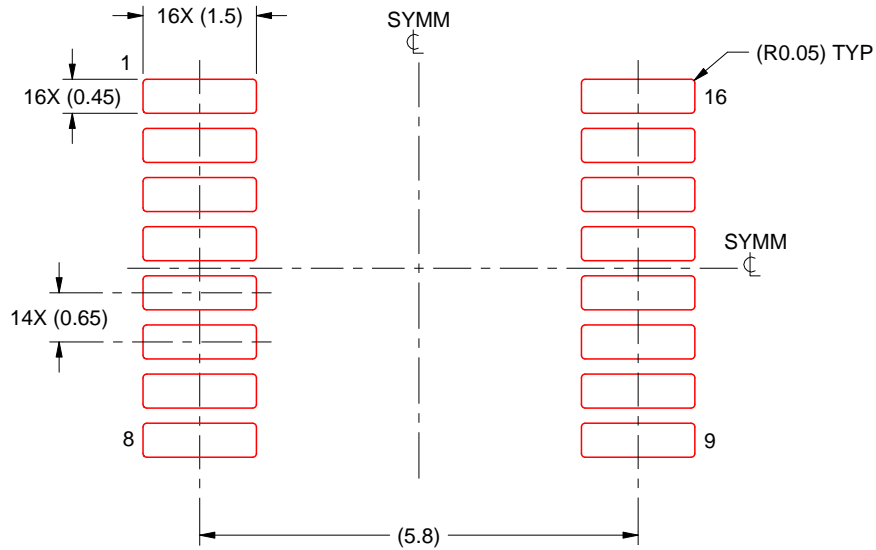

SOLDER PASTE EXAMPLE
BASED ON 0.125 mm THICK STENCIL
SCALE: 10X

4220204/B 12/2023

NOTES: (continued)

8. Laser cutting apertures with trapezoidal walls and rounded corners may offer better paste release. IPC-7525 may have alternate design recommendations.
9. Board assembly site may have different recommendations for stencil design.

D (R-PDSO-G16)

PLASTIC SMALL OUTLINE



- NOTES:
- A. All linear dimensions are in inches (millimeters).
 - B. This drawing is subject to change without notice.
 - C. Body length does not include mold flash, protrusions, or gate burrs. Mold flash, protrusions, or gate burrs shall not exceed 0.006 (0,15) each side.
 - D. Body width does not include interlead flash. Interlead flash shall not exceed 0.017 (0,43) each side.
 - E. Reference JEDEC MS-012 variation AC.

IMPORTANT NOTICE AND DISCLAIMER

TI PROVIDES TECHNICAL AND RELIABILITY DATA (INCLUDING DATASHEETS), DESIGN RESOURCES (INCLUDING REFERENCE DESIGNS), APPLICATION OR OTHER DESIGN ADVICE, WEB TOOLS, SAFETY INFORMATION, AND OTHER RESOURCES "AS IS" AND WITH ALL FAULTS, AND DISCLAIMS ALL WARRANTIES, EXPRESS AND IMPLIED, INCLUDING WITHOUT LIMITATION ANY IMPLIED WARRANTIES OF MERCHANTABILITY, FITNESS FOR A PARTICULAR PURPOSE OR NON-INFRINGEMENT OF THIRD PARTY INTELLECTUAL PROPERTY RIGHTS.

These resources are intended for skilled developers designing with TI products. You are solely responsible for (1) selecting the appropriate TI products for your application, (2) designing, validating and testing your application, and (3) ensuring your application meets applicable standards, and any other safety, security, regulatory or other requirements.

These resources are subject to change without notice. TI grants you permission to use these resources only for development of an application that uses the TI products described in the resource. Other reproduction and display of these resources is prohibited. No license is granted to any other TI intellectual property right or to any third party intellectual property right. TI disclaims responsibility for, and you fully indemnify TI and its representatives against any claims, damages, costs, losses, and liabilities arising out of your use of these resources.

TI's products are provided subject to [TI's Terms of Sale](#), [TI's General Quality Guidelines](#), or other applicable terms available either on [ti.com](#) or provided in conjunction with such TI products. TI's provision of these resources does not expand or otherwise alter TI's applicable warranties or warranty disclaimers for TI products. Unless TI explicitly designates a product as custom or customer-specified, TI products are standard, catalog, general purpose devices.

TI objects to and rejects any additional or different terms you may propose.

Copyright © 2026, Texas Instruments Incorporated

Last updated 10/2025