

DS90C241 and DS90C124 5-MHz to 35-MHz DC-Balanced 24-Bit FPD-Link II Serializer and Deserializer

1 Features

- 5-MHz to 35-MHz Clock Embedded and DC-Balancing 24:1 and 1:24 Data Transmissions
- User Defined Pre-Emphasis Driving Ability Through External Resistor on LVDS Outputs and Capable to Drive Up to 10-Meter Shielded Twisted-Pair Cable
- User-Selectable Clock Edge for Parallel Data on Both Transmitter and Receiver
- Internal DC Balancing Encode and Decode (Supports AC-Coupling Interface With No External Coding Required)
- Individual Power-Down Controls for Both Transmitter and Receiver
- Embedded Clock CDR (Clock and Data Recovery) on Receiver and No External Source of Reference Clock Required
- All Codes RDL (Random Data Lock) to Support Live-Pluggable Applications
- LOCK Output Flag to Ensure Data Integrity at Receiver Side
- Balanced T_{SETUP} and T_{HOLD} Between RCLK and RDATA on Receiver Side
- PTO (Progressive Turnon) LVCMOS Outputs to Reduce EMI and Minimize SSO Effects
- All LVCMOS Inputs and Control Pins Have Internal Pulldown
- On-Chip Filters for PLLs on Transmitter and Receiver
- Temperature Range: -40°C to 105°C
- Greater Than 8-kV HBM ESD Tolerant
- Meets AEC-Q100 Compliance
- Power Supply Range: $3.3\text{ V} \pm 10\%$
- 48-Pin TQFP Package

2 Applications

- Automotive Central Information Displays
- Automotive Instrument Cluster Displays
- Automotive Heads-Up Displays
- Remote Camera-Based Driver Assistance Systems

3 Description

The DS90C241 and DS90C124 chipset translates a 24-bit parallel bus into a fully transparent data and control LVDS serial stream with embedded clock information. This single serial stream simplifies transferring a 24-bit bus over PCB traces or over cable by eliminating the skew problems between parallel data and clock paths. It saves system cost by narrowing data paths, which in turn reduces PCB layers, cable width, and connector size and pins.

The DS90C241 and DS90C124 incorporate LVDS signaling on the high-speed I/O. LVDS provides a low-power and low-noise environment for reliably transferring data over a serial transmission path. By optimizing the serializer output edge rate for the operating frequency range, EMI is further reduced.

In addition, the device features pre-emphasis to boost signals over longer distances using lossy cables. Internal DC balanced encoding and decoding supports AC-coupled interconnects.

Device Information⁽¹⁾

PART NUMBER	PACKAGE	BODY SIZE (NOM)
DS90C124	TQFP (48)	7.00 mm x 7.00 mm
DS90C241		

(1) For all available packages, see the orderable addendum at the end of the data sheet.

Block Diagram

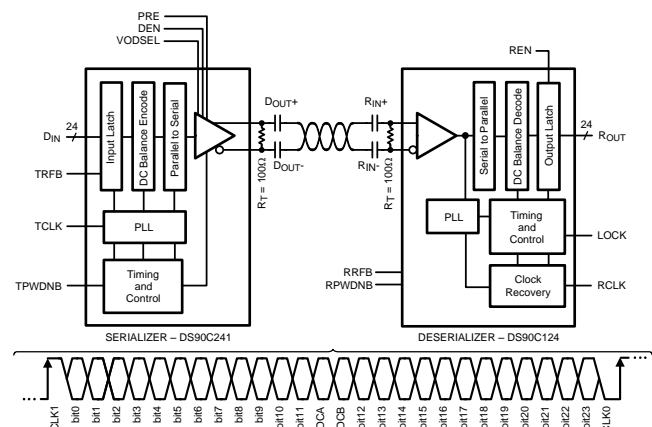

Copyright © 2017, Texas Instruments Incorporated



Table of Contents

1 Features	1	8.3 Feature Description	17
2 Applications	1	8.4 Device Functional Modes	20
3 Description	1	9 Applications and Implementation	22
4 Revision History	2	9.1 Application Information	22
5 Pin Configuration and Functions	3	9.2 Typical Application	22
6 Specifications	7	10 Power Supply Recommendations	27
6.1 Absolute Maximum Ratings	7	11 Layout	28
6.2 ESD Ratings	7	11.1 Layout Guidelines	28
6.3 Recommended Operating Conditions	7	11.2 Layout Example	29
6.4 Thermal Information	8	12 Device and Documentation Support	32
6.5 Electrical Characteristics	8	12.1 Documentation Support	32
6.6 Timing Requirements – Serializer	9	12.2 Related Links	32
6.7 Switching Characteristics – Serializer	10	12.3 Receiving Notification of Documentation Updates	32
6.8 Switching Characteristics – Deserializer	10	12.4 Community Resources	32
6.9 Typical Characteristics	11	12.5 Trademarks	32
7 Parameter Measurement Information	12	12.6 Electrostatic Discharge Caution	32
8 Detailed Description	17	12.7 Glossary	32
8.1 Overview	17	13 Mechanical, Packaging, and Orderable Information	33
8.2 Functional Block Diagram	17		

4 Revision History

NOTE: Page numbers for previous revisions may differ from page numbers in the current version.

Changes from Revision L (April 2013) to Revision M	Page
• Added <i>ESD Ratings</i> table, <i>Feature Description</i> section, <i>Device Functional Modes</i> , <i>Application and Implementation</i> section, <i>Power Supply Recommendations</i> section, <i>Layout</i> section, <i>Device and Documentation Support</i> section, and <i>Mechanical, Packaging, and Orderable Information</i> section	1
• Deleted Lead temperature, soldering (260°C maximum) from <i>Absolute Maximum Ratings</i>	7
• Added <i>Thermal Information</i> table	8
• Added <i>Typical Characteristics</i> (PCLK = 5 MHz and PCLK = 25 MHz plus pre-emphasis)	11

Changes from Revision K (April 2013) to Revision L	Page
• Changed layout of National Semiconductor Data Sheet to TI format	1

5 Pin Configuration and Functions

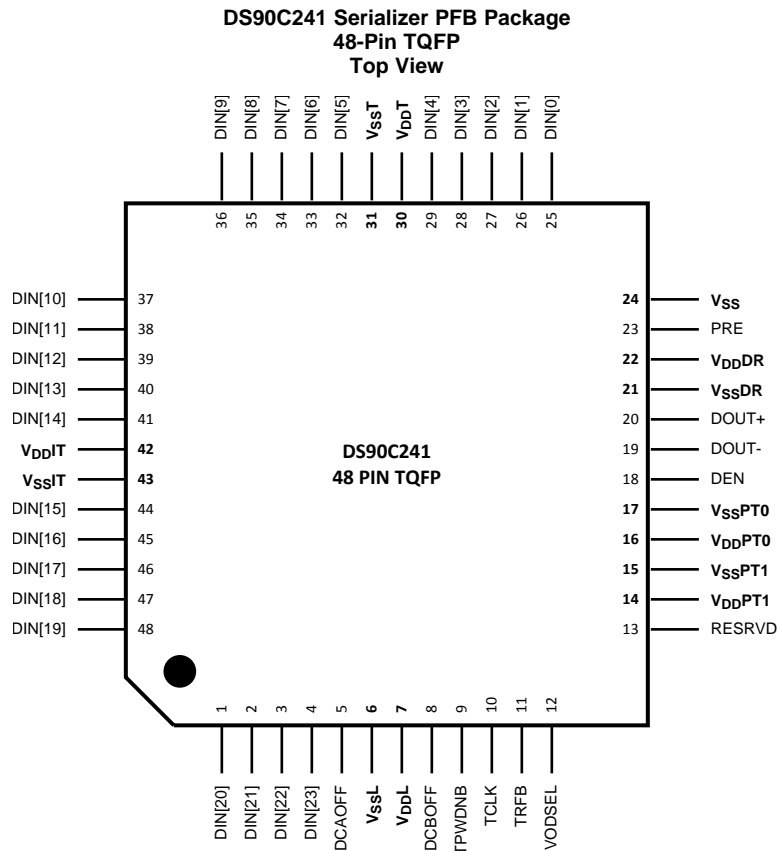

Pin Functions – DS90C241 Serializer

PIN		TYPE ⁽¹⁾	DESCRIPTION
NAME	NO.		
LVC MOS PARALLEL INTERFACE PINS			
DIN[23:0]	4-1, 48-44, 41-32, 29-25	I	LVC MOS, Transmitter parallel interface data input pins. Tie LOW if unused, do not float.
TCLK	10	I	LVC MOS, Transmitter parallel interface clock input pin. Strobe edge set by TRFB configuration pin.
CONTROL AND CONFIGURATION PINS			
DCAOFF	5	I	LVC MOS, Reserved. This pin <i>must</i> be tied LOW.
DCBOFF	8	I	LVC MOS, Reserved. This pin <i>must</i> be tied LOW.
DEN	18	I	LVC MOS, Transmitter data enable. DEN = H; LVDS driver outputs are enabled (ON). DEN = L; LVDS driver outputs are disabled (OFF), Transmitter LVDS driver D _{OUT} (±) outputs are in TRI-STATE, PLL still operational and locked to TCLK.
PRE	23	I	LVC MOS, Pre-emphasis level select. PRE = NC (No Connect); Pre-emphasis is disabled (OFF). Pre-emphasis is active when input is tied to VSS through external resistor R _{PRE} . Resistor value determines pre-emphasis level. Recommended value R _{PRE} ≥ 3 kΩ; I _{max} = [(1.2/R) × 20], R _{min} = 3 kΩ
RESRVD	13	I	LVC MOS, Reserved. This pin <i>must</i> be tied LOW.
TPWDNB	9	I	LVC MOS, Transmitter power down bar. TPWDNB = H; Transmitter is enabled and ON TPWDNB = L; Transmitter is in power down mode (Sleep), LVDS driver D _{OUT} (±) outputs are in TRI-STATE stand-by mode, PLL is shutdown to minimize power consumption.

(1) G = Ground, I = Input, O = Output, P = Power

Pin Functions – DS90C241 Serializer (continued)

PIN		TYPE ⁽¹⁾	DESCRIPTION
NAME	NO.		
TRFB	11	I	LVC MOS, Transmitter clock edge select pin. TRFB = H; Parallel interface data is strobed on the rising clock edge. TRFB = L; Parallel interface data is strobed on the falling clock edge.
VODSEL	12	I	LVC MOS, VOD Level select VODSEL = L; LVDS driver output is approximately ± 400 mV ($R_L = 100 \Omega$) VODSEL = H; LVDS driver output is approximately ± 750 mV ($R_L = 100 \Omega$) For normal applications, set this pin LOW. For long cable applications where a larger VOD is required, set this pin HIGH.
LVDS SERIAL INTERFACE PINS			
DOUT-	19	O	LVDS, Transmitter LVDS inverted (-) output This output is intended to be loaded with a 100- Ω load to the D _{OUT-} pin. The interconnect must be AC-coupled to this pin with a 100-nF capacitor.
DOUT+	20	O	LVDS, Transmitter LVDS true (+) output. This output is intended to be loaded with a 100- Ω load to the D _{OUT+} pin. The interconnect must be AC-coupled to this pin with a 100-nF capacitor.
POWER OR GROUND PINS			
VDDDR	22	P	VDD, Analog voltage supply, LVDS output power
VDDIT	42	P	VDD, Digital voltage supply, Tx input power
VDDL	7	P	VDD, Digital voltage supply, Tx logic power
VDDPT0	16	P	VDD, Analog voltage supply, VCO power
VDDPT1	14	P	VDD, Analog voltage supply, PLL power
VDDT	30	P	VDD, Digital voltage supply, Tx serializer power
VSS	24	G	ESD ground
VSSDR	21	G	Analog ground, LVDS output ground
VSSIT	43	G	Digital ground, Tx input ground
VSSL	6	G	Digital ground, Tx logic ground
VSSPT0	17	G	Analog ground, VCO ground
VSSPT1	15	G	Analog ground, PLL ground
VSST	31	G	Digital ground, Tx serializer ground

**DS90C124 Deserializer PFB Package
48-Pin TQFP
Top View**

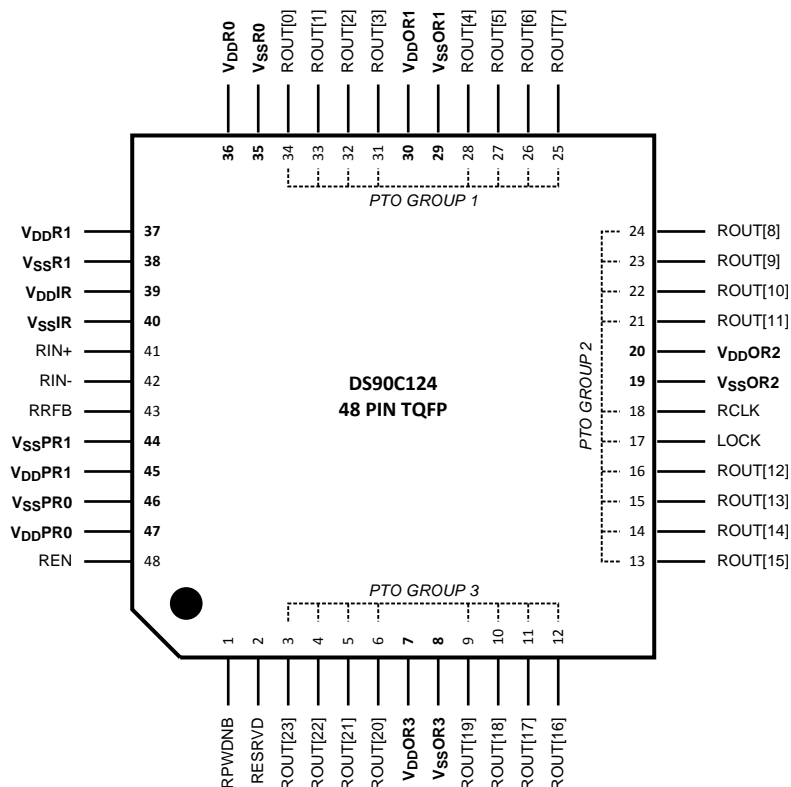

Pin Functions – DS90C124 Deserializer

PIN		TYPE ⁽¹⁾	DESCRIPTION
NAME	NO.		
LVC MOS PARALLEL INTERFACE PINS			
RCLK	18	O	LVC MOS, Parallel interface clock output pin. Strobe edge set by RRF B configuration pin.
ROUT[7:0]	25-28, 31-34	O	LVC MOS, Receiver LVC MOS level outputs – Group 1
ROUT[15:8]	13-16, 21-24	O	LVC MOS, Receiver LVC MOS level outputs – Group 2
ROUT[23:16]	3-6, 9-12	O	LVC MOS, Receiver LVC MOS level outputs – Group 3
CONTROL AND CONFIGURATION PINS			
REN	48	I	LVC MOS, Receiver data enable REN = H; R _{OUT} [23:0] and RCLK are enabled (ON). REN = L; R _{OUT} [23:0] and RCLK are disabled (OFF), receiver R _{OUT} [23:0] and RCLK outputs are in TRI-STATE, PLL still operational and locked to TCLK.
LOCK	17	O	LVC MOS, LOCK indicates the status of the receiver PLL LOCK = H; receiver PLL is locked LOCK = L; receiver PLL is unlocked, R _{OUT} [23:0] and RCLK are TRI-STATED
RESRVD	2	I	LVC MOS, Reserved. This pin <i>must</i> be tied LOW.
RPWDB	1	I	LVC MOS, Receiver power down bar. RPWDB = H; Receiver is enabled and ON RPWDB = L; Receiver is in power down mode (Sleep), R _{OUT} [23:0], RCLK, and LOCK are in TRI-STATE standby mode, PLL is shutdown to minimize power consumption.
RRFB	43	I	LVC MOS, Receiver clock edge select pin. RRFB = H; R _{OUT} LVC MOS outputs strobed on the rising clock edge. RRFB = L; R _{OUT} LVC MOS outputs strobed on the falling clock edge.

(1) G = Ground, I = Input, O = Output, P = Power

Pin Functions – DS90C124 Deserializer (continued)

PIN		TYPE ⁽¹⁾	DESCRIPTION
NAME	NO.		
LVDS SERIAL INTERFACE PINS			
RIN-	42	I	Receiver LVDS Inverted (-) Input This input is intended to be terminated with a 100- Ω load to the R _{IN-} pin. The interconnect must be AC-coupled to this pin with a 100-nF capacitor.
RIN+	41	I	Receiver LVDS True (+) input This input is intended to be terminated with a 100- Ω load to the R _{IN+} pin. The interconnect must be AC-coupled to this pin with a 100-nF capacitor.
POWER OR GROUND PINS			
VDDIR	39	P	VDD, Analog LVDS voltage supply, power
VDDOR1	30	P	VDD, Digital voltage supply, LVCMOS output power
VDDOR2	20	P	VDD, Digital voltage supply, LVCMOS output power
VDDOR3	7	P	VDD, Digital voltage supply, LVCMOS output power
VDDPR0	47	P	VDD, Analog voltage supply, PLL power
VDDPR1	45	P	VDD, Analog voltage supply, PLL VCO power
VDDR0	36	P	VDD, Digital voltage supply, Logic power
VDDR1	37	P	VDD, Digital voltage supply, Logic power
VSSIR	40	G	Analog LVDS ground
VSSOR1	29	G	Digital ground, LVCMOS output ground
VSSOR2	19	G	Digital ground, LVCMOS output ground
VSSOR3	8	G	Digital ground, LVCMOS output ground
VSSPR0	46	G	Analog ground, PLL ground
VSSPR1	44	G	Analog ground, PLL VCO ground
VSSR0	35	G	Digital ground, Logic ground
VSSR1	38	G	Digital ground, Logic ground

6 Specifications

6.1 Absolute Maximum Ratings

over operating free-air temperature range (unless otherwise noted)⁽¹⁾

		MIN	MAX	UNIT
V _{CC}	Supply voltage	-0.3	4	V
	LVC MOS/LVTTL input voltage	-0.3	V _{CC} + 0.3	V
	LVC MOS/LVTTL output voltage	-0.3	V _{CC} + 0.3	V
	LVDS receiver input voltage	-0.3	3.9	V
	LVDS driver output voltage	-0.3	3.9	V
	LVDS output short circuit duration		10	ms
T _J	Junction temperature		150	°C
T _{stg}	Storage temperature	-65	150	°C

- (1) Stresses beyond those listed under *Absolute Maximum Ratings* may cause permanent damage to the device. These are stress ratings only, which do not imply functional operation of the device at these or any other conditions beyond those indicated under *Recommended Operating Conditions*. Exposure to absolute-maximum-rated conditions for extended periods may affect device reliability.

6.2 ESD Ratings

		VALUE	UNIT	
V _(ESD)	Electrostatic discharge	Human-body model (HBM), per AEC Q100-002 ⁽¹⁾	±8000	V
		Charged-device model (CDM), per AEC Q100-011	±1250	
	R _D = 330 Ω, C _S = 150 pF	IEC, powered-up only contact discharge (R _{IN0+} , R _{IN0-} , R _{IN1+} , R _{IN1-})	±8000	
		IEC, powered-up only air-gap discharge (R _{IN0+} , R _{IN0-} , R _{IN1+} , R _{IN1-})	±15000	
	R _D = 330 Ω, C _S = 150 and 330 pF	ISO10605 contact discharge (R _{IN0+} , R _{IN0-} , R _{IN1+} , R _{IN1-})	±8000	
		ISO10605 air-gap discharge (R _{IN0+} , R _{IN0-} , R _{IN1+} , R _{IN1-})	±15000	
	R _D = 2 kΩ, C _S = 150 and 330 pF	ISO10605 contact discharge (R _{IN0+} , R _{IN0-} , R _{IN1+} , R _{IN1-})	±8000	
		ISO10605 air-gap discharge (R _{IN0+} , R _{IN0-} , R _{IN1+} , R _{IN1-})	±15000	

- (1) AEC Q100-002 indicates that HBM stressing shall be in accordance with the ANSI/ESDA/JEDEC JS-001 specification.

6.3 Recommended Operating Conditions

over operating free-air temperature range (unless otherwise noted)

		MIN	NOM	MAX	UNIT
V _{CC}	Supply voltage	3	3.3	3.6	V
	Clock rate	5		35	MHz
	Supply noise			±100	mV _{P-P}
T _A	Operating free-air temperature	-40	25	105	°C

6.4 Thermal Information

THERMAL METRIC ⁽¹⁾		DS90C241-Q1 DS90C124-Q1	UNIT
		TFB (TQFP)	
		48 PINS	
R _{θJA}	Junction-to-ambient thermal resistance	67.5	°C/W
R _{θJC(top)}	Junction-to-case (top) thermal resistance	15.1	°C/W
R _{θJB}	Junction-to-board thermal resistance	33.4	°C/W
ψ _{JT}	Junction-to-top characterization parameter	0.4	°C/W
ψ _{JB}	Junction-to-board characterization parameter	33	°C/W

(1) For more information about traditional and new thermal metrics, see the [Semiconductor and IC Package Thermal Metrics](#) application report.

6.5 Electrical Characteristics

over recommended operating supply and temperature ranges (unless otherwise noted)

PARAMETER		TEST CONDITIONS	MIN	TYP	MAX	UNIT		
LVC MOS AND LV TTL DC SPECIFICATIONS								
V _{IH}	High-level voltage	Tx: DIN[23:0], TCLK, TPWDNB, DEN, TRFB, DCAOFF, DCBOFF, and VODSEL; and Rx: RPWDNB, RRFB, and REN	2		V _{CC}	V		
V _{IL}	Low-level input voltage	Tx: DIN[23:0], TCLK, TPWDNB, DEN, TRFB, DCAOFF, DCBOFF, and VODSEL; and Rx: RPWDNB, RRFB, and REN	GND		0.8	V		
V _{CL}	Input clamp voltage	I _{CL} = -18 mA, Tx: DIN[23:0], TCLK, TPWDNB, DEN, TRFB, DCAOFF, DCBOFF, and VODSEL; and Rx: RPWDNB, RRFB, and REN ⁽¹⁾		-0.8	-1.5	V		
I _{IN}	Input current	V _{IN} = 0 V or 3.6 V	Tx: DIN[23:0], TCLK, TPWDNB, DEN, TRFB, DCAOFF, DCBOFF, and VODSEL		-10	±5	10	μA
			Rx: RPWDNB, RRFB, and REN		-20	±5	20	
V _{OH}	High-level output voltage	I _{OH} = -4 mA, Rx: ROUT[23:0], RCLK, and LOCK	2.3	3	V _{CC}	V		
V _{OL}	Low-level output voltage	I _{OL} = 4 mA, Rx: ROUT[23:0], RCLK, and LOCK	GND	0.33	0.5	V		
I _{OS}	Output short circuit current	V _{OUT} = 0 V, Rx: ROUT[23:0], RCLK, and LOCK ⁽¹⁾	-40	-70	-110	mA		
I _{OZ}	TRI-STATE output current	RPWDNB, REN = 0 V, V _{OUT} = 0 V or 2.4 V, Rx: ROUT[23:0], RCLK, and LOCK	-30	±0.4	30	μA		
LVDS DC SPECIFICATIONS								
V _{TH}	Differential threshold high voltage	V _{CM} = 1.2 V, Rx: R _{IN+} and R _{IN-}			50	mV		
V _{TL}	Differential threshold low voltage	Rx: R _{IN+} and R _{IN-}	-50			mV		
I _{IN}	Input current	V _{IN} = 2.4 V, V _{CC} = 3.6 V or 0 V, Rx: R _{IN+} and R _{IN-}			±200	μA		
		V _{IN} = 0 V, V _{CC} = 3.6 V, Rx: R _{IN+} and R _{IN-}			±200			
V _{OD}	Output differential voltage (D _{OUT+}) - (D _{OUT-})	R _L = 100 Ω, without pre-emphasis, Tx: D _{OUT+} and D _{OUT-} (see Figure 12)	VODSEL = L		250	400	600	mV
			VODSEL = H		450	750	1200	
ΔV _{OD}	Output differential voltage unbalance	R _L = 100 Ω, without pre-emphasis, Tx: D _{OUT+} and D _{OUT-}		10	50	mV		
V _{OS}	Offset voltage	R _L = 100 Ω, without pre-emphasis, Tx: D _{OUT+} and D _{OUT-}	1	1.25	1.5	V		
ΔV _{OS}	Offset voltage unbalance	R _L = 100 Ω, without pre-emphasis, Tx: D _{OUT+} and D _{OUT-}		1	50	mV		

(1) Specification is ensured by characterization and is not tested in production.

Electrical Characteristics (continued)

over recommended operating supply and temperature ranges (unless otherwise noted)

PARAMETER		TEST CONDITIONS	MIN	TYP	MAX	UNIT
I_{OS}	Output short circuit current	DOUT = 0 V, DIN = H, TPWDNB, DEN = 2.4 V, Tx: D _{OUT+} and D _{OUT-} , VODSEL = L	-2		-8	mA
		DOUT = 0 V, DIN = H, TPWDNB, DEN = 2.4 V, Tx: D _{OUT+} and D _{OUT-} , VODSEL = H	-7		-13	
I_{OZ}	TRI-STATE output current	TPWDNB, DEN = 0 V, DOUT = 0 V or 2.4 V, Tx: D _{OUT+} and D _{OUT-}	-15	±1	15	μA
SERIALIZER OR DESERIALIZER SUPPLY CURRENT – DVDDx, PVDDx, AND AVDDx PINS (<i>Digital, PLL, and Analog VDDs</i>)						
I_{CCT}	Serializer (Tx) total supply current (includes load current)	R _L = 100 Ω, R _{PRE} = OFF, VODSEL = H/L, f = 35 MHz, and checker-board pattern (see Figure 3)		40	65	mA
		R _L = 100 Ω, R _{PRE} = 6 kΩ, VODSEL = H/L, f = 35 MHz, and checker-board pattern (see Figure 3)		45	70	mA
	Serializer (Tx) total supply current (includes load current)	f = 35 MHz, R _L = 100 Ω, R _{PRE} = OFF, and VODSEL = H/L		40	65	mA
		f = 35 MHz, R _L = 100 Ω, R _{PRE} = 6 kΩ, VODSEL = H/L, and random pattern		45	70	mA
I_{CCTZ}	Serializer (Tx) supply current power-down	TPWDNB = 0 V (all other LVCMOS inputs = 0 V)			800	μA
I_{CCR}	Deserializer (Rx) total supply current (includes load current)	C _L = 8-pF LVCMOS output, f = 35 MHz, and checker-board pattern (see Figure 4)			85	mA
	Deserializer (Rx) total supply current (includes load current)	C _L = 8-pF LVCMOS output, f = 35 MHz, and random pattern			80	mA
I_{CCRZ}	Deserializer (Rx) supply current power-down	RPWDNB = 0 V (all other LVCMOS inputs = 0 V, R _{IN+} / R _{IN-} = 0 V)			50	μA

6.6 Timing Requirements – Serializer

over recommended operating supply and temperature ranges (unless otherwise noted)

		MIN	TYP	MAX	UNIT
t_{TCP}	Transmit clock period (see Figure 7)	28.6	T	200	ns
t_{TCH}	Transmit clock high time	0.4T	0.5T	0.6T	ns
t_{TCL}	Transmit clock low time	0.4T	0.5T	0.6T	ns
t_{CLKT}	TCLK input transition time (see Figure 6)		3	6	ns
t_{JIT}	TCLK input jitter ⁽¹⁾			33	ps (RMS)

(1) t_{JIT} (at BER of 10e-9) specifies the allowable jitter on TCLK. t_{JIT} not included in TxOUT_E_O parameter.

6.7 Switching Characteristics – Serializer

over recommended operating supply and temperature ranges (unless otherwise noted)

PARAMETER	TEST CONDITIONS	MIN	TYP	MAX	UNIT
t_{LLHT}	LVDS Low-to-High transition time $R_L = 100 \Omega$, $C_L = 10 \text{ pF}$ to GND, and VODSEL = L (see Figure 5)			0.6	ns
t_{LHLT}	LVDS High-to-Low transition time $R_L = 100 \Omega$, $C_L = 10 \text{ pF}$ to GND, and VODSEL = L (see Figure 5)			0.6	ns
t_{DIS}	DIN[23:0] setup to TCLK $R_L = 100 \Omega$ and $C_L = 10 \text{ pF}$ to GND ⁽¹⁾	5			ns
t_{DIH}	DIN[23:0] hold from TCLK $R_L = 100 \Omega$ and $C_L = 10 \text{ pF}$ to GND ⁽¹⁾	5			ns
t_{HZD}	DOU \pm HIGH to TRI-STATE delay $R_L = 100 \Omega$ and $C_L = 10 \text{ pF}$ to GND (see Figure 8) ⁽²⁾			15	ns
t_{LZD}	DOU \pm LOW to TRI-STATE delay $R_L = 100 \Omega$ and $C_L = 10 \text{ pF}$ to GND (see Figure 8) ⁽²⁾			15	ns
t_{ZHD}	DOU \pm TRI-STATE to HIGH delay $R_L = 100 \Omega$ and $C_L = 10 \text{ pF}$ to GND (see Figure 8) ⁽²⁾			200	ns
t_{ZLD}	DOU \pm TRI-STATE to LOW delay $R_L = 100 \Omega$ and $C_L = 10 \text{ pF}$ to GND (see Figure 8) ⁽²⁾			200	ns
t_{PLD}	Serializer PLL lock time $R_L = 100 \Omega$ (see Figure 9)			10	ms
t_{SD}	Serializer delay $R_L = 100 \Omega$, VODSEL = L, and TRFB = H (see Figure 10)		3.5T + 2.85	3.5T + 10	ns
			3.5T + 2.85	3.5T + 10	ns
TxOUT_E_O	TxOUT_Eye_Opening (respect to ideal) 5 MHz to 35 MHz (see Figure 11) ⁽¹⁾⁽³⁾⁽⁴⁾	0.75			UI ⁽⁵⁾

(1) Specification is ensured by characterization and is not tested in production.

 (2) When the serializer output is tri-stated, the deserializer loses PLL lock. Resynchronization *must* occur before data transfer.

 (3) t_{JIT} (at BER of 10e-9) specifies the allowable jitter on TCLK. t_{JIT} not included in TxOUT_E_O parameter.

(4) TxOUT_E_O is affected by pre-emphasis value.

(5) UI – Unit Interval; equivalent to one ideal serialized data bit width. The UI scales with frequency.

6.8 Switching Characteristics – Deserializer

over recommended operating supply and temperature ranges (unless otherwise noted)

PARAMETER	TEST CONDITIONS	MIN	TYP	MAX	UNIT
t_{RCP}	Receiver out clock period $t_{RCP} = t_{TCP}$ and RCLK pin ⁽¹⁾	28.6		200	ns
t_{RDC}	RCLK duty cycle RCLK pin	45%	50%	55%	
t_{CLH}	LVC MOS low-to-high transition time $C_L = 8 \text{ pF}$ (lumped load); ROUT[23:0], LOCK, and RCLK pins (see Figure 13) ⁽¹⁾		2.5	3.5	ns
t_{CHL}	LVC MOS high-to-low transition time $C_L = 8 \text{ pF}$ (lumped load); ROUT[23:0], LOCK, and RCLK pins (see Figure 13) ⁽¹⁾		2.5	3.5	ns
t_{ROS}	ROUT[7:0] setup data to RCLK (Group 1) ROUT[7:0] pins (see Figure 17)	$0.4 \times t_{RCP}$	$(29/56) \times t_{RCP}$		ns
t_{ROH}	ROUT[7:0] hold data to RCLK (Group 1) ROUT[7:0] pins (see Figure 17)	$0.4 \times t_{RCP}$	$(27/56) \times t_{RCP}$		ns
t_{ROS}	ROUT[15:8] setup data to RCLK (Group 2) ROUT[15:8] and LOCK pins (see Figure 17)	$0.4 \times t_{RCP}$	$0.5 \times t_{RCP}$		ns
t_{ROH}	ROUT[15:8] hold data to RCLK (Group 2) ROUT[15:8] and LOCK pins (see Figure 17)	$0.4 \times t_{RCP}$	$0.5 \times t_{RCP}$		ns
t_{ROS}	ROUT[23:16] setup data to RCLK (Group 3) ROUT[23:16] pins (see Figure 17)	$0.4 \times t_{RCP}$	$(27/56) \times t_{RCP}$		ns
t_{ROH}	ROUT[23:16] hold data to RCLK (Group 3) ROUT[23:16] pins (see Figure 17)	$0.4 \times t_{RCP}$	$(29/56) \times t_{RCP}$		ns
t_{HZR}	HIGH to TRI-STATE delay ROUT[23:0], RCLK, and LOCK pins (see Figure 15)		3	10	ns

(1) Specification is ensured by characterization and is not tested in production.

Switching Characteristics – Deserializer (continued)

over recommended operating supply and temperature ranges (unless otherwise noted)

PARAMETER	TEST CONDITIONS	MIN	TYP	MAX	UNIT	
t_{LZR}	LOW to TRI-STATE delay	ROUT[23:0], RCLK, and LOCK pins		3	10	ns
t_{ZHR}	TRI-STATE to HIGH delay	ROUT[23:0], RCLK, and LOCK pins		3	10	ns
t_{ZLR}	TRI-STATE to LOW delay	ROUT[23:0], RCLK, and LOCK pins		3	10	ns
t_{DD}	Deserializer delay	RCLK pin (see Figure 14)		$[4+(3/56)]T + 5.9$	$[4+(3/56)]T + 14$	ns
t_{DRDL}	Deserializer PLL lock time from power down	See Figure 16 ⁽¹⁾⁽²⁾		5	50	ms
				35 MHz	50	
RxIN_TOL_L	Receiver input tolerance (left)	5 MHz to 35 MHz (see Figure 18) ⁽¹⁾⁽³⁾			0.25	UI ⁽⁴⁾
RxIN_TOL_R	Receiver input tolerance (right)	5 MHz to 35 MHz (see Figure 18) ⁽¹⁾⁽³⁾			0.25	UI ⁽⁴⁾

- (2) The deserializer PLL lock time (t_{DRDL}) may vary depending on input data patterns and the number of transitions within the pattern.
- (3) RxIN_TOL is a measure of how much phase noise (jitter) the deserializer can tolerate in the incoming data stream before bit errors occur. It is a measurement in reference with the ideal bit position. See *AN-1217 How to Validate BLVDS SER/DES Signal Integrity Using an Eye Mask* (SNLA053) for details.
- (4) UI – Unit Interval; equivalent to one ideal serialized data bit width. The UI scales with frequency.

6.9 Typical Characteristics

Figure 1 and Figure 2 are scope shots with PCLK = 5 MHz measured out of the DS90C241 DOUT± with pre-emphasis OFF and pre-emphasis ON using a 1010... pattern on the DIN[23:0] inputs. The scope was triggered on the input PCLK.

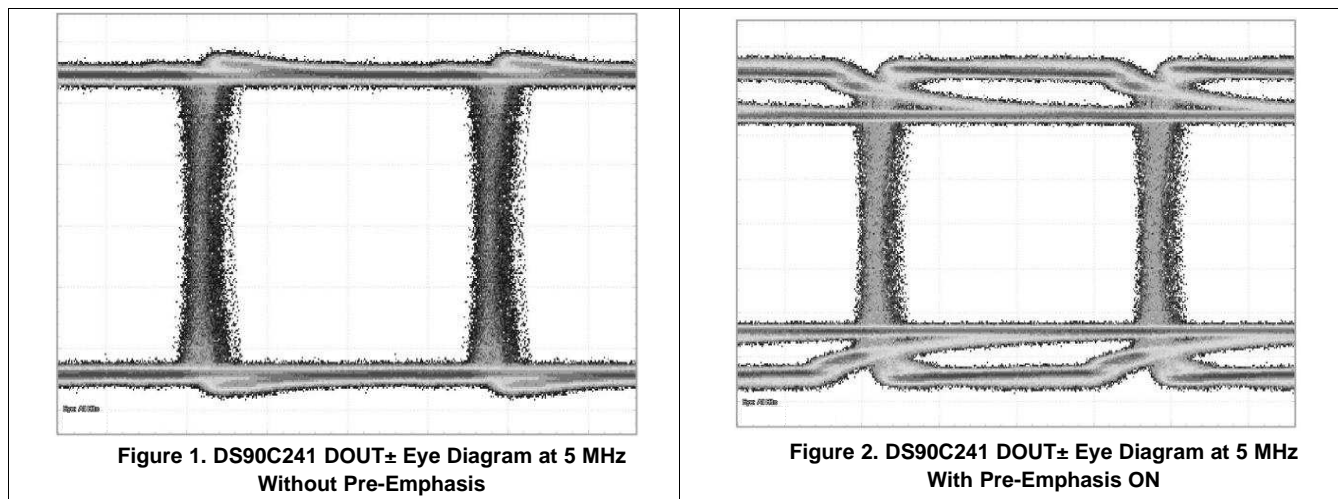

7 Parameter Measurement Information

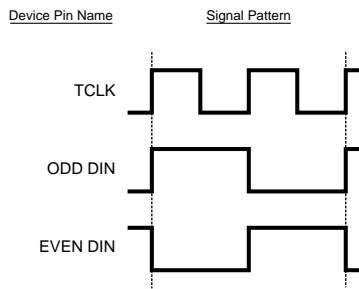

Figure 3. Serializer Input Checkerboard Pattern

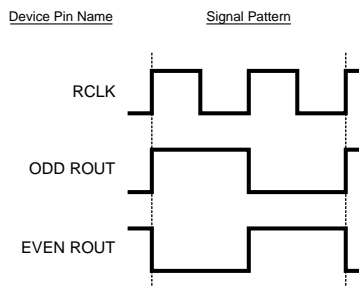

Figure 4. Deserializer Output Checkerboard Pattern

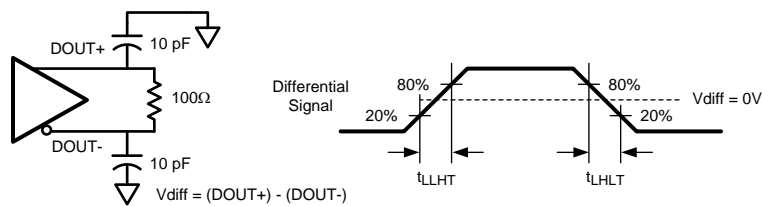

Figure 5. Serializer LVDS Output Load and Transition Times

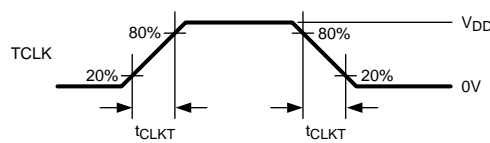

Figure 6. Serializer Input Clock Transition Times

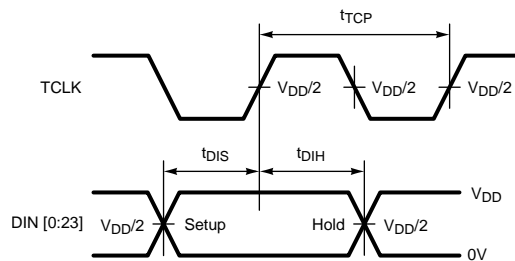

Figure 7. Serializer Setup and Hold Times

Parameter Measurement Information (continued)

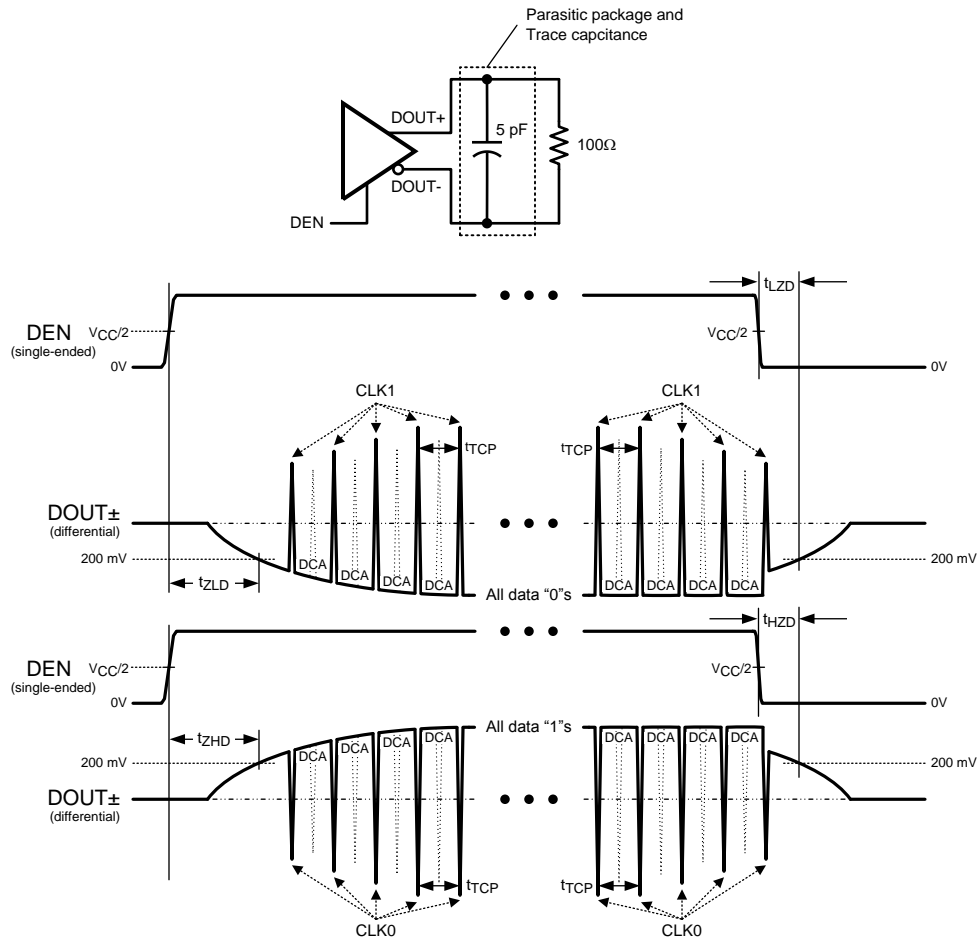

Figure 8. Serializer TRI-STATE Test Circuit and Delay

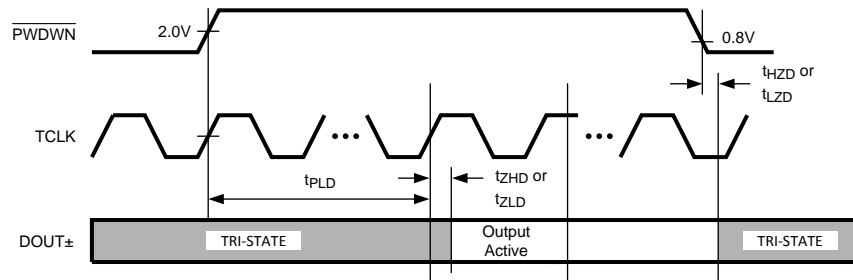

Figure 9. Serializer PLL Lock Time and TPWDNB TRI-STATE Delays

Parameter Measurement Information (continued)

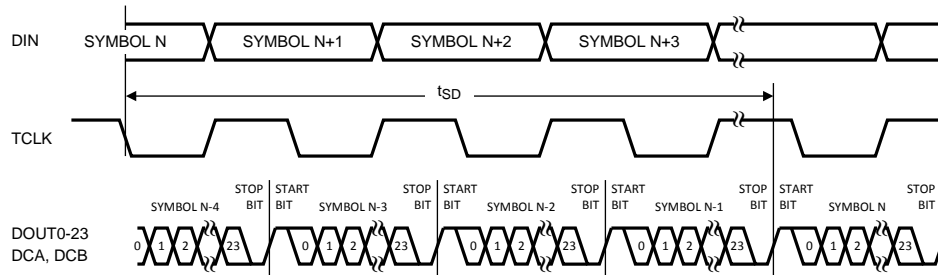

Figure 10. Serializer Delay

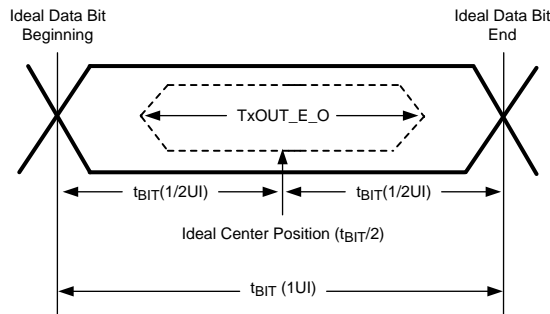
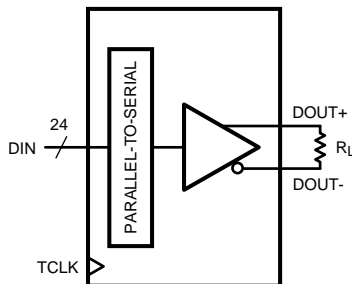

Figure 11. Transmitter Output Eye Opening (TxOUT_E_O)



$$VOD = (D_{OUT+}) - (D_{OUT-})$$

Differential output signal is shown as (D_{OUT+}) – (D_{OUT-}) with the device in data transfer mode.

Figure 12. Serializer VOD Diagram

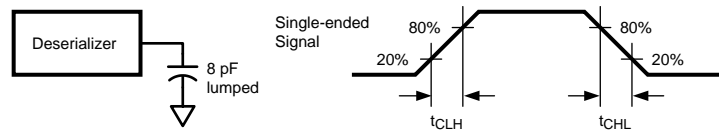

Figure 13. Deserializer LVCMOS/LVTTL Output Load and Transition Times

Parameter Measurement Information (continued)

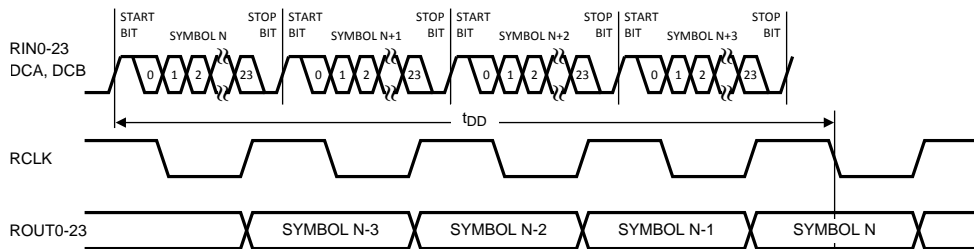
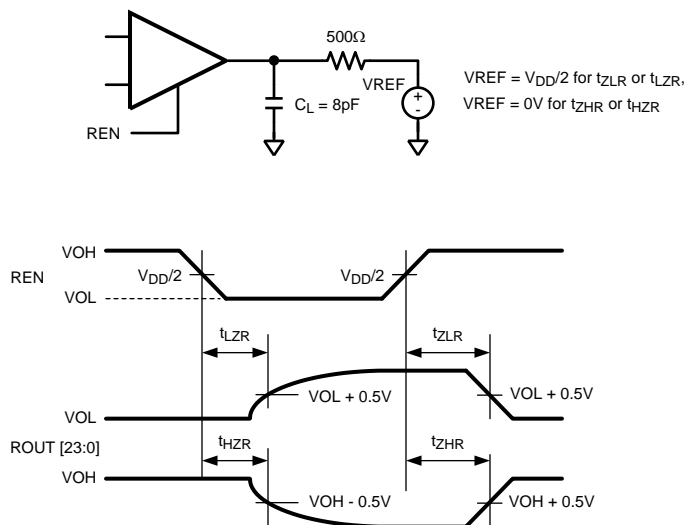

Figure 14. Deserializer Delay



C_L includes instrumentation and fixture capacitance within 6 cm of ROUT[23:0].

Figure 15. Deserializer TRI-STATE Test Circuit and Timing

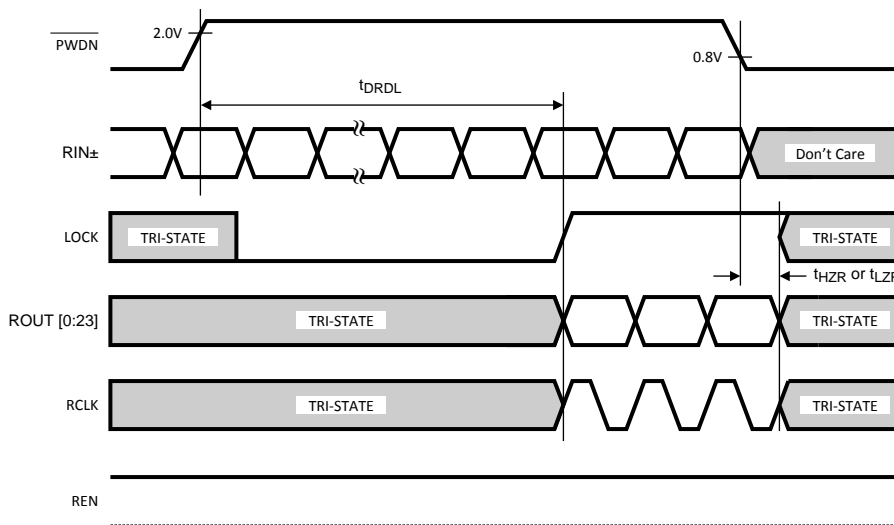

Figure 16. Deserializer PLL Lock Times and RPWDBN TRI-STATE Delay

Parameter Measurement Information (continued)

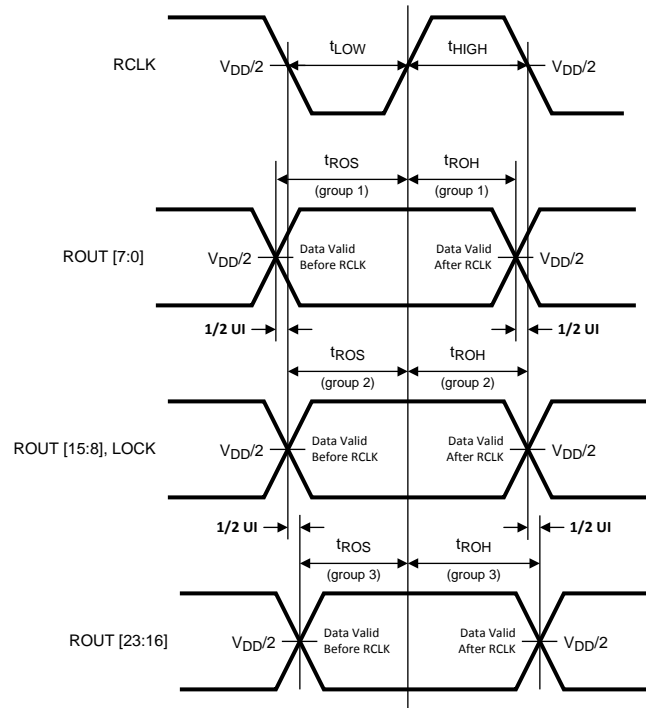
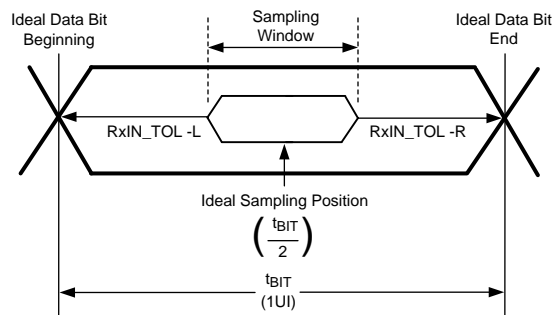

Figure 17. Deserializer Setup and Hold Times



RxIN_TOL_L is the ideal noise margin on the left of the figure with respect to ideal.
 RxIN_TOL_R is the ideal noise margin on the right of the figure with respect to ideal.

Figure 18. Receiver Input Tolerance (RxIN_TOL) and Sampling Window

8 Detailed Description

8.1 Overview

The DS90C241 serializer and DS90C124 deserializer chipset is an easy-to-use transmitter and receiver pair that sends 24-bits of parallel LVCMOS data over a single serial LVDS link from 120 Mbps to 840 Mbps throughput. The DS90C241 transforms a 24-bit wide parallel LVCMOS data into a single high speed LVDS serial data stream with embedded clock, and scrambles or DC balances the data to enhance signal quality to support AC coupling. The DS90C124 receives the LVDS serial data stream and converts it back into a 24-bit wide parallel data and recovered clock. The 24-bit serializer or deserializer chipset is designed to transmit data up to 10 meters over shielded twisted pair (STP) at clock speeds from 5 MHz to 35 MHz.

The deserializer can attain lock to a data stream without the use of a separate reference clock source. This greatly simplifies system complexity and overall cost. The deserializer synchronizes to the serializer regardless of data pattern, delivering true automatic *plug and lock* performance. It locks to the incoming serial stream without the requirement of special training patterns or sync characters. The deserializer recovers the clock and data by extracting the embedded clock information and validating data integrity from the incoming data stream and then deserializes the data. The deserializer monitors the incoming clock information, determines lock status, and asserts the LOCK output high when lock occurs. Each has a power down control to enable efficient operation in various applications.

8.2 Functional Block Diagram

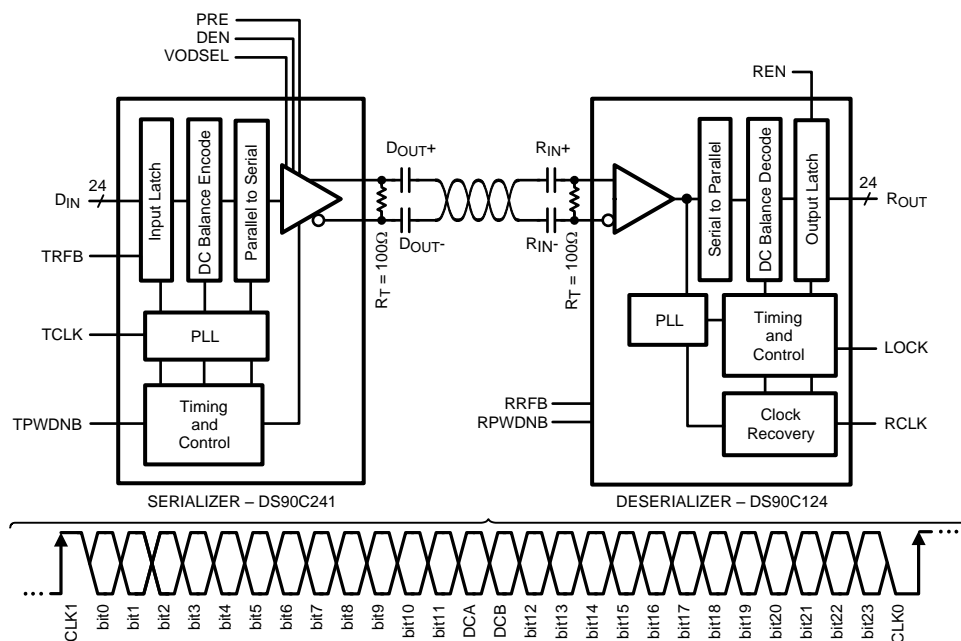

Copyright © 2017, Texas Instruments Incorporated

8.3 Feature Description

8.3.1 Initialization and Locking Mechanism

Initialization of the DS90C241 and DS90C124 must be established before each device sends or receives data. Initialization refers to synchronizing the PLLs of the serializer and the deserializer together. After the serializers locks to the input clock source, the deserializer synchronizes to the serializers as the second and final initialization step.

1. When V_{CC} is applied to both serializer or deserializer, the respective outputs are held in TRI-STATE and internal circuitry is disabled by on-chip power-on circuitry. When V_{CC} reaches $V_{CC\ OK}$ (2.2 V) the PLL in serializer begins locking to a clock input. For the serializer, the local clock is the transmit clock, TCLK. The serializer outputs are held in TRI-STATE while the PLL locks to the TCLK. After locking to TCLK, the

Feature Description (continued)

serializer block is now ready to send data patterns. The deserializer output remains in TRI-STATE while its PLL locks to the embedded clock information in serial data stream. Also, the deserializer LOCK output remains low until its PLL locks to incoming data and sync-pattern on the RIN± pins.

2. The deserializer PLL acquires lock to a data stream without requiring the serializer to send special patterns. The serializer that is generating the stream to the deserializer automatically sends random (non-repetitive) data patterns during this step of the Initialization State. The deserializer locks onto the embedded clock within the specified amount of time. An embedded clock and data recovery (CDR) circuit locks to the incoming bit stream to recover the high-speed receive bit clock and re-time incoming data. The CDR circuit expects a coded input bit stream. In order for the deserializer to lock to a random data stream from the serializer, it performs a series of operations to identify the rising clock edge and validates data integrity, then locks to it. Because this locking procedure is independent on the data pattern, total random locking duration may vary. At the point when the CDR of the deserializer locks to the embedded clock, the LOCK pin goes high and valid RCLK/data appears on the outputs. Note that the LOCK signal is synchronous to valid data appearing on the outputs. The deserializer's LOCK pin is a convenient way to ensure data integrity is achieved on receiver side.

8.3.2 Data Transfer

After serializer lock is established, the inputs DIN0 to DIN23 may be used to input data to the serializer. Data is clocked into the serializer by the TCLK input. The edge of TCLK used to strobe the data is selectable through the TRFB pin. TRFB high selects the rising edge for clocking data and low selects the falling edge. The serializer outputs (DOUT±) are intended to drive point-to-point connections as shown in [Figure 19](#).

CLK1, CLK0, DCA, DCB are four overhead bits transmitted along the single LVDS serial data stream. The CLK1 bit is always high and the CLK0 bit is always low. The CLK1 and CLK0 bits function as the embedded clock bits in the serial stream. DCB functions as the DC Balance control bit. It does not require any precoding of data on transmit side. The DC Balance bit is used to minimize the short and long-term DC bias on the signal lines. This bit operates by selectively sending the data either unmodified or inverted. The DCA bit is used to validate data integrity in the embedded data stream. Both DCA and DCB coding schemes are integrated and automatically performed within serializer and deserializer.

Serialized data and clock or control bits (24 +4 bits) are transmitted from the serial data output (DOUT±) at 28 times the TCLK frequency. For example, if TCLK is 35 MHz, the serial rate is $35 \times 28 = 980$ Mega bits per second. Because only 24 bits are from input data, the serial *payload* rate is 24 times the TCLK frequency. For example, if TCLK = 35 MHz, the payload data rate is $35 \times 24 = 840$ Mbps. TCLK is provided by the data source and must be in the range of 5 MHz to 35 MHz nominal. The serializer outputs (DOUT±) can drive a point-to-point connection. The outputs transmit data when the enable pin (DEN) is high, TPWDNB is high. The DEN pin may be used to TRI-STATE the outputs when driven low.

When the deserializer channel attains lock to the input from a serializer, it drives its LOCK pin high and synchronously delivers valid data and recovered clock on the output. The deserializer locks onto the embedded clock, uses it to generate multiple internal data strobes, and then drives the recovered clock to the RCLK pin. The recovered clock (RCLK output pin) is synchronous to the data on the ROUT[23:0] pins. While LOCK is high, data on ROUT[23:0] is valid. Otherwise, ROUT[23:0] is invalid. The polarity of the RCLK edge is controlled by the RRFB input. ROUT[23:0], LOCK, and RCLK outputs each drive a maximum of 8-pF load with 35-MHz clock. REN controls TRI-STATE for ROUTn and the RCLK pin on the deserializer.

8.3.3 Resynchronization

If the deserializer loses lock, it automatically tries to re-establish lock. For example, if the embedded clock edge is not detected one time in succession, the PLL loses lock and the LOCK pin is driven low. The deserializer then enters the operating mode where it tries to lock to a random data stream. It looks for the embedded clock edge, identifies it and then proceeds through the locking process. The logic state of the LOCK signal indicates whether the data on ROUT is valid; when it is high, the data is valid. The system must monitor the LOCK pin to determine whether data on the ROUT is valid.

Feature Description (continued)

8.3.4 Pre-Emphasis

The DS90C241 features a pre-emphasis function used to compensate for long or lossy transmission media. Cable drive is enhanced with a user selectable pre-emphasis feature that provides additional output current during transitions to counteract cable loading effects. The transmission distance is limited by the loss characteristics and quality of the media. Pre-emphasis adds extra current during LVDS logic transition to reduce the cable loading effects and increase driving distance. In addition, pre-emphasis helps provide faster transitions, increased eye openings, and improved signal integrity. To enable the pre-emphasis function, the *PRE* pin requires one external resistor (R_{pre}) to V_{ss} to set the additional current level. Pre-emphasis strength is set through an external resistor (R_{pre}) applied from min to max (floating to 3 k Ω) at the *PRE* pin. A lower input resistor value on the *PRE* pin increases the magnitude of dynamic current during data transition. There is an internal current source based on the following formula: $PRE = (R_{pre} \geq 3 \text{ k}\Omega)$; $I_{MAX} = [(1.2/R_{pre}) \times 20]$. The ability of the DS90C241 to use the pre-emphasis feature extends the transmission distance up to 10 meters in most cases.

The amount of pre-emphasis for a given media depends on the transmission distance of the application. In general, too much pre-emphasis can cause over or undershoot at the receiver input pins. This can result in excessive noise, crosstalk and increased power dissipation. For short cables or distances, pre-emphasis may not be required. Signal quality measurements are recommended to determine the proper amount of pre-emphasis for each application.

8.3.5 AC-Coupling and Termination

The DS90C241 and DS90C124 supports AC-coupled interconnects through integrated DC balanced encoding/decoding scheme. To use AC coupled connection between the serializer and deserializer, insert external AC coupling capacitors in series in the LVDS signal path as illustrated in Figure 19. The deserializer input stage is designed for AC-coupling by providing a built-in AC bias network which sets the internal V_{CM} to 1.2 V. With AC signal coupling, capacitors provide the AC-coupling path to the signal input.

For the high-speed LVDS transmissions, the smallest available package must be used for the AC-coupling capacitor. This helps minimize degradation of signal quality due to package parasitics. The most common used capacitor value for the interface is 100-nF (0.1- μ F) capacitor. NPO class 1 or X7R class 2 type capacitors are recommended. 50-WVDC must be the minimum used for the best system-level ESD performance.

The DS90C124 input stage is designed for AC-coupling by providing a built-in AC bias network which sets the internal V_{CM} to 1.2 V. Therefore multiple termination options are possible.

8.3.5.1 Receiver Termination Options

8.3.5.1.1 Option 1

A single, 100- Ω termination resistor is placed across the RIN_{\pm} pins (see Figure 19). This provides the signal termination at the receiver inputs. Other options may be used to increase noise tolerance.

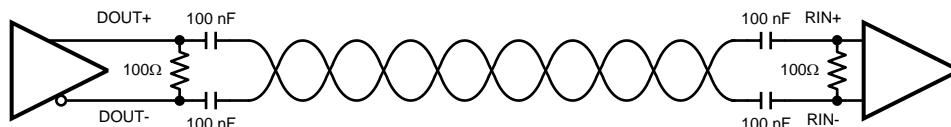
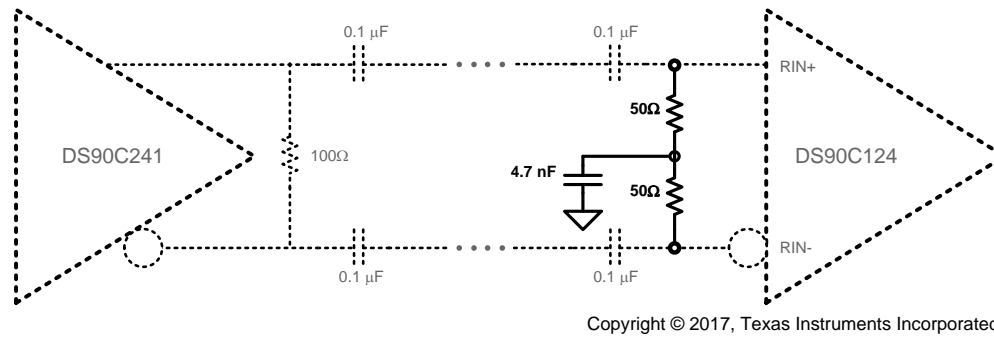

Figure 19. AC Coupled Application

8.3.5.1.1.1 Option 2

For additional EMI tolerance, two 50- Ω resistors may be used in place of the single 100- Ω resistor. A small capacitor is tied from the center point of the 50- Ω resistors to ground (see Figure 20). This provides a high-frequency low impedance path for noise suppression. Value is not critical; 4.7 nF may be used with general applications.

Feature Description (continued)

Figure 20. Receiver Termination Option 2
8.3.5.1.1.2 Option 3

For high noise environments an additional voltage divider network may be connected to the center point. This has the advantage of providing a DC low-impedance path for noise suppression. Use resistor values in the range of 75 Ω to 2 KΩ for the pullup and pulldown. Ratio the resistor values to bias the center point at 1.2 V. For example (see Figure 21), VDD = 3.3 V, R_{pullup} = 1.3 kΩ, R_{pulldown} = 750 Ω; or R_{pullup} = 130 Ω, R_{pulldown} = 75 Ω (strongest). The smaller values consume more bias current, but provide enhanced noise suppression.

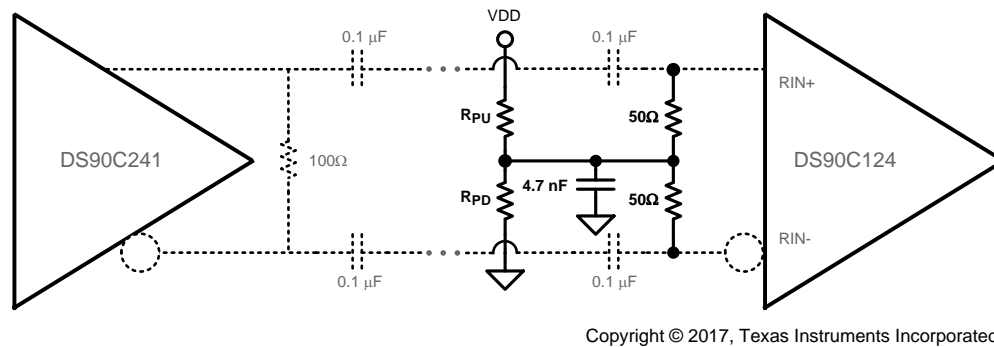

Figure 21. Receiver Termination Option 3
8.4 Device Functional Modes

Table 1 and Table 2 list the truth tables for the serializer and deserializer.

Table 1. DS90C241 Serializer Truth Table

TPWDNB (PIN 9)	DEN (PIN 18)	Tx PLL STATUS (INTERNAL)	LVDS OUTPUTS (PINS 19 AND 20)
L	X	X	Hi Z
H	L	X	Hi Z
H	H	Not locked	Hi Z
H	H	Locked	Serialized data with embedded clock

Table 2. DS90C124 Deserializer Truth Table

RPWDNB (PIN 1)	REN (PIN 48)	Rx PLL STATUS (INTERNAL)	ROUTn AND RCLK (SEE PIN DIAGRAM)	LOCK (PIN 17)
L	X	X	Hi Z	Hi Z
H	L	X	Hi Z	L = PLL unocked H = PLL locked
H	H	Not locked	Hi Z	L

Table 2. DS90C124 Deserializer Truth Table (continued)

RPWDBN (PIN 1)	REN (PIN 48)	Rx PLL STATUS (INTERNAL)	ROUTn AND RCLK (SEE PIN DIAGRAM)	LOCK (PIN 17)
H	H	Locked	Data and RCLK active	H

8.4.1 Power Down

The power-down state is a low power sleep mode that the serializer and deserializer may use to reduce power when no data is being transferred. The TPWDBN and RPWDBN are used to set each device into power down mode, which reduces supply current to the μA range. The serializer enters power down when the TPWDBN pin is driven low. In power down, the PLL stops and the outputs go into TRI-STATE, disabling load current and reducing supply. To exit power down, TPWDBN must be driven high. When the serializer exits power down, its PLL must lock to TCLK before it is ready for the Initialization state. The system must then allow time for Initialization before data transfer can begin. The deserializer enters power down mode when RPWDBN is driven low. In power down mode, the PLL stops and the outputs enter TRI-STATE. To bring the deserializer block out of the power down state, the system drives RPWDBN high.

Both the serializer and deserializer must reinitialize and relock before data can be transferred. The deserializer initializes and asserts LOCK high when it is locked to the input clock.

8.4.2 Tri-State

For the serializer, TRI-STATE is entered when the DEN or TPWDBN pin is driven low. This does TRI-STATE both driver output pins (DOUT+ and DOUT-). When DEN is driven high, the serializer returns to the previous state as long as all other control pins remain static (TPWDBN, TRFB).

When you drive the REN or RPWDBN pin low, the deserializer enters TRI-STATE. Consequently, the receiver output pins (ROUT0 to ROUT23) and RCLK enters TRI-STATE. The LOCK output remains active, reflecting the state of the PLL. The deserializer input pins are high impedance during receiver power down (RPWDBN low) and power-off ($V_{CC} = 0\text{ V}$).

8.4.3 Progressive Turn-On (PTO)

Deserializer ROUT[23:0] outputs are grouped into three groups of eight, with each group switching about 0.5-UI apart in phase to reduce EMI, simultaneous switching noise, and system ground bounce.

9 Applications and Implementation

NOTE

Information in the following applications sections is not part of the TI component specification, and TI does not warrant its accuracy or completeness. TI's customers are responsible for determining suitability of components for their purposes. Customers should validate and test their design implementation to confirm system functionality.

9.1 Application Information

9.1.1 Using the DS90C241 and DS90C124

The DS90C241/DS90C124 serializer or deserializer (SERDES) pair sends 24 bits of parallel LVCMOS data over a serial LVDS link up to 840 Mbps. Serialization of the input data is accomplished using an on-board PLL at the serializer which embeds clock with the data. The deserializer extracts the clock/control information from the incoming data stream and deserializes the data. The deserializer monitors the incoming clock information to determine lock status and indicates lock by asserting the LOCK output high.

9.1.2 Display Application

The DS90C241/DS90C124 chipset is intended for interface between a host (graphics processor) and a display. It supports an 18-bit color depth (RGB666) and up to 800 × 480 display formats. In a RGB666 configuration 18 color bits (R[5:0], G[5:0], B[5:0]), Pixel Clock (PCLK) and three control bits (VS, HS, and DE) along with three spare bits are supported across the serial link with PCLK rates from 5 MHz to 35 MHz.

9.2 Typical Application

[Figure 22](#) shows a typical application of the DS90C241 serializer (SER). The LVDS outputs use a 100-Ω termination and 100-nF coupling capacitors to the line. Bypass capacitors are placed near the power supply pins. A system General Purpose Output (GPO) controls the TPWDNB pin. In this application the TRFB pin is tied High to latch data on the rising edge of the TCLK. The DEN signal is not used and is tied High also. In this application, the link is short; therefore, the VODSEL pin is tied Low for the standard LVDS swing. The pre-emphasis input uses a resistor to ground to set the amount of pre-emphasis desired by the application.

[Figure 23](#) shows a typical application of the DS90C124 deserializer (DES). The LVDS inputs use a 100-Ω termination and 100-nF coupling capacitors to the line. Bypass capacitors are placed near the power supply pins. A system GPO controls the RPWDNB pin. In this application, the RRFB pin is tied high to strobe the data on the rising edge of the RCLK. The REN signal is not used and is tied high also.

Typical Application (continued)

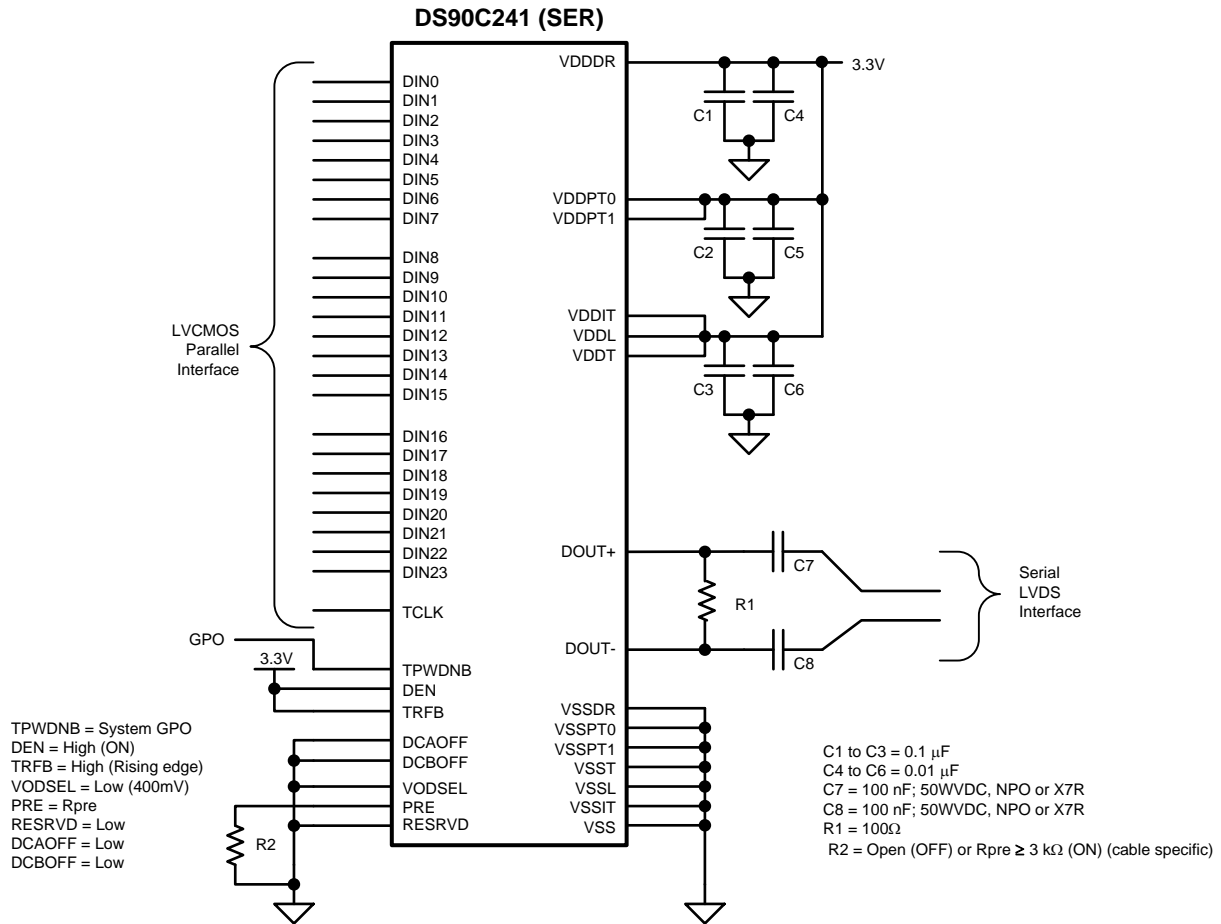

Copyright © 2017, Texas Instruments Incorporated

Figure 22. DS90C241 Typical Application Connection

Typical Application (continued)

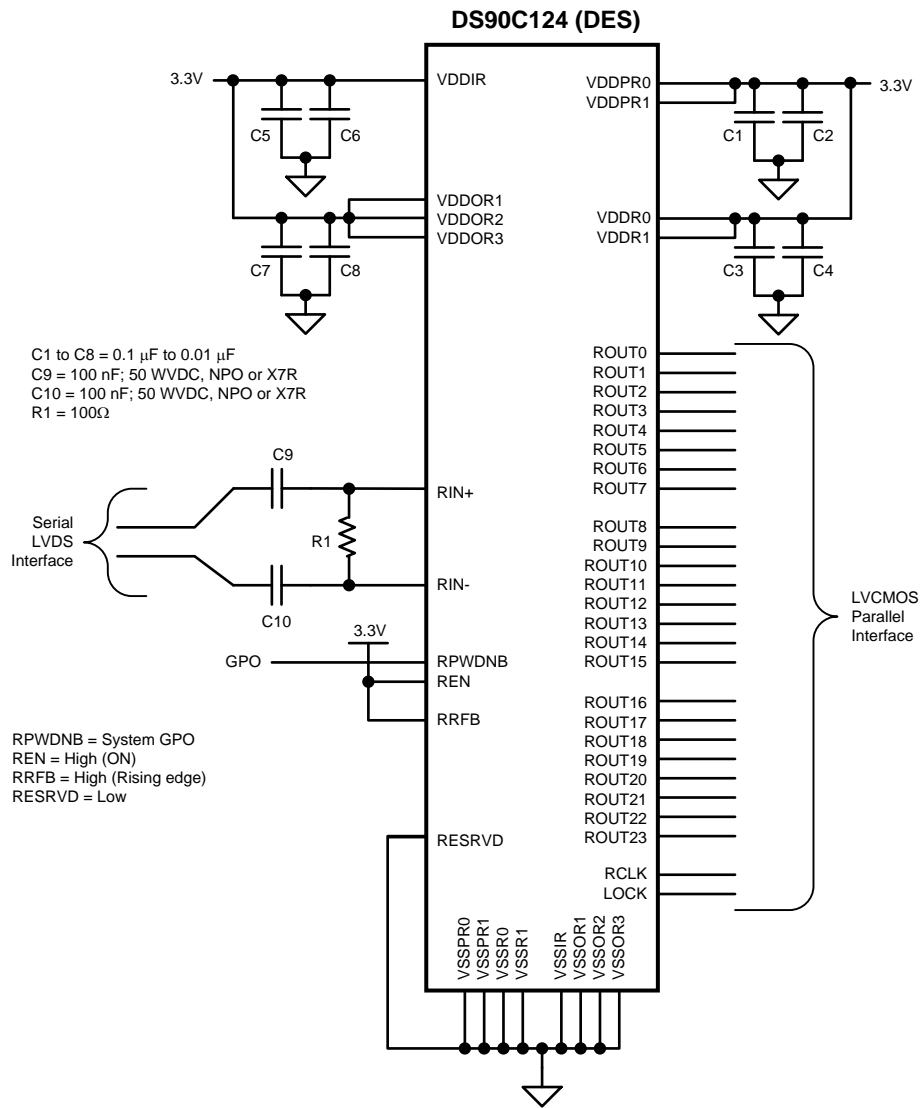

Copyright © 2017, Texas Instruments Incorporated

Figure 23. DS90C124 Typical Application Connection

9.2.1 Design Requirements

For the typical design application, use the following as input parameters:

The SER/DES supports only AC-coupled interconnects through an integrated DC-balanced decoding scheme. External AC coupling capacitors must be placed in series in the FPD-Link III signal path as illustrated in Figure 22 and Figure 23.

Typical Application (continued)

9.2.2 Detailed Design Procedure

Circuit board layout and stack-up for the LVDS serializer and deserializer devices must be designed to provide low-noise power to the device. Good layout practice also separates high frequency or high-level inputs and outputs to minimize unwanted stray noise, feedback and interference. Power system performance may be greatly improved by using thin dielectrics (2 to 4 mil) for power and ground sandwiches. This arrangement uses the plane capacitance for the PCB power system and has low-inductance, which has proven effectiveness especially at high frequencies, and makes the value and placement of external bypass capacitors less critical. External bypass capacitors must include both RF ceramic and tantalum electrolytic types. RF capacitors may use values in the range of 0.01 μF to 10 μF . Tantalum capacitors may be in the 2.2- μF to 10- μF range. The voltage rating of the tantalum capacitors must be at least 5 times the power supply voltage being used.

MLCC surface mount capacitors are recommended due to their smaller parasitic properties. When using multiple capacitors per supply pin, place the smaller value closer to the pin. A large bulk capacitor is recommended at the point of power entry. This is typically in the 50 μF to 100 μF range and smooth low frequency switching noise. TI recommends connecting power and ground pins directly to the power and ground planes with bypass capacitors connected to the plane with through on both ends of the capacitor. Connecting power or ground pins to an external bypass capacitor will increase the inductance of the path. A small body size X7R chip capacitor, such as 0603 or 0805, is recommended for external bypass. A small body sized capacitor has less inductance. The user must pay attention to the resonance frequency of these external bypass capacitors, usually in the range from 20 MHz to 30 MHz. To provide effective bypassing, multiple capacitors are often used to achieve low impedance between the supply rails over the frequency of interest. At high frequency, it is also a common practice to use two vias from power and ground pins to the planes, reducing the impedance at high frequency. Use at least a four layer board with a power and ground plane. Place LVCMOS signals away from the LVDS lines to prevent coupling from the LVCMOS lines to the LVDS lines. Closely coupled differential lines of 100 Ω are typically recommended for LVDS interconnect. The closely coupled lines help to ensure that coupled noise will appear as common mode and thus is rejected by the receivers. The tightly coupled lines will also radiate less.

9.2.2.1 Noise Margin

The deserializer noise margin is the amount of input jitter (phase noise) that the deserializer can tolerate and still reliably recover data. Various environmental and systematic factors include:

- Serializer: TCLK jitter, V_{CC} noise (noise bandwidth and out-of-band noise)
- Media: ISI, V_{CM} noise
- Deserializer: V_{CC} noise

For a graphical representation of noise margin, see [Figure 18](#).

9.2.2.2 Transmission Media

The serializer and deserializer can be used in point-to-point configuration, through a PCB trace, or through twisted pair cable. In a point-to-point configuration, the transmission media requires termination at both ends of the transmitter and receiver pair. Interconnect for LVDS typically has a differential impedance of 100 Ω . Use cables and connectors that have matched differential impedance to minimize impedance discontinuities. In most applications that involve cables, the transmission distance is determined on data rates involved, acceptable bit error rate and transmission medium.

The resulting signal quality at the receiving end of the transmission media may be assessed by monitoring the differential eye opening of the serial data stream. The Receiver Input Tolerance in [Switching Characteristics – Deserializer](#) and the Differential Threshold Voltage specifications in [Electrical Characteristics](#) define the acceptable data eye opening. A differential probe must be used to measure across the termination resistor at the DS90C124 inputs. [Figure 24](#) illustrates the eye opening and relationship to the receiver input tolerance and differential threshold voltage specifications.

Typical Application (continued)

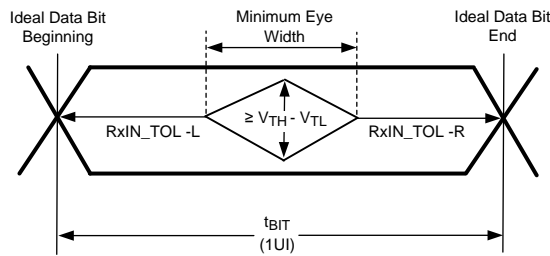

Figure 24. Receiver Input Eye Opening

9.2.2.3 Live Link Insertion

The serializer and deserializer devices support live pluggable applications. The automatic receiver lock to random data *plug and go* hot insertion capability allows the DS90C124 to attain lock to the active data stream during a live insertion event.

9.2.3 Application Curves

Figure 25, Figure 26, and Figure 27 are scope shots with PCLK = 25 MHz into the DS90C241 with a 1010... pattern on the DIN[23:0] inputs. The scope was triggered on the input PCLK.

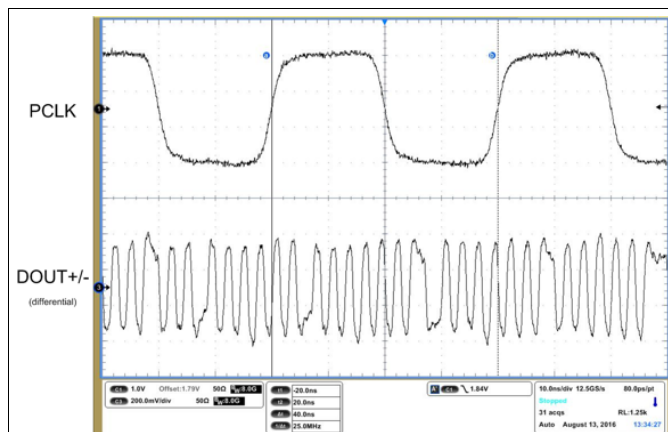

Figure 25. Input PCLK = 25 MHz and Associated DOUT Serial Stream

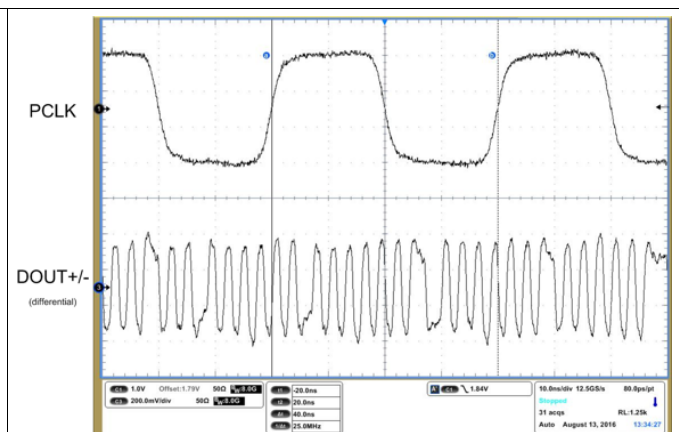

Figure 26. Input PCLK = 25 MHz and Associated DOUT Serial Stream With Pre-Emphasis

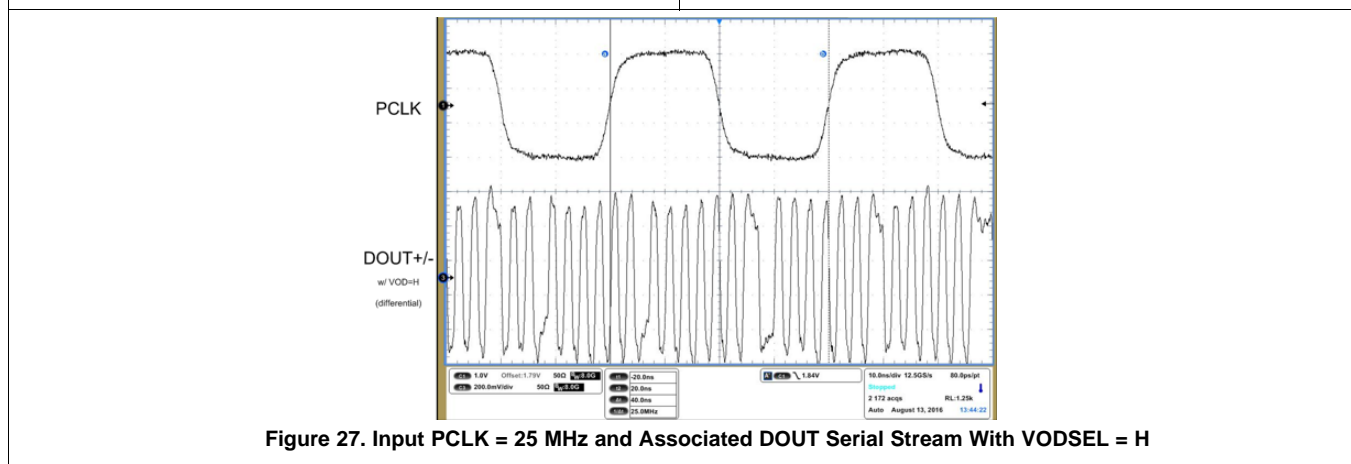

Figure 27. Input PCLK = 25 MHz and Associated DOUT Serial Stream With VODSEL = H

Typical Application (continued)

Figure 28, Figure 29, and Figure 30 are scope shots with PCLK = 33 MHz into the DS90C241 with a 1010... pattern on the DIN[23:0] inputs. The scope was triggered on the input PCLK.

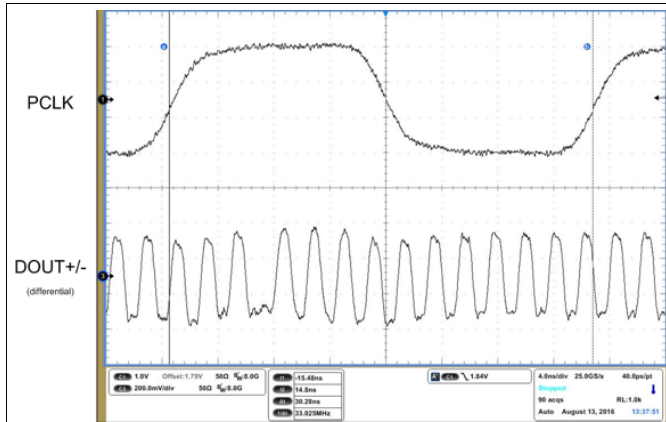

Figure 28. Input PCLK = 33 MHz and Associated DOUT Serial Stream

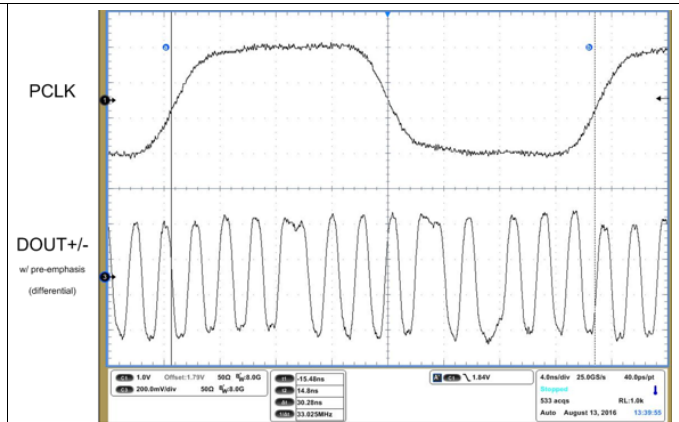

Figure 29. Input PCLK = 33 MHz and Associated DOUT Serial Stream With Pre-Emphasis

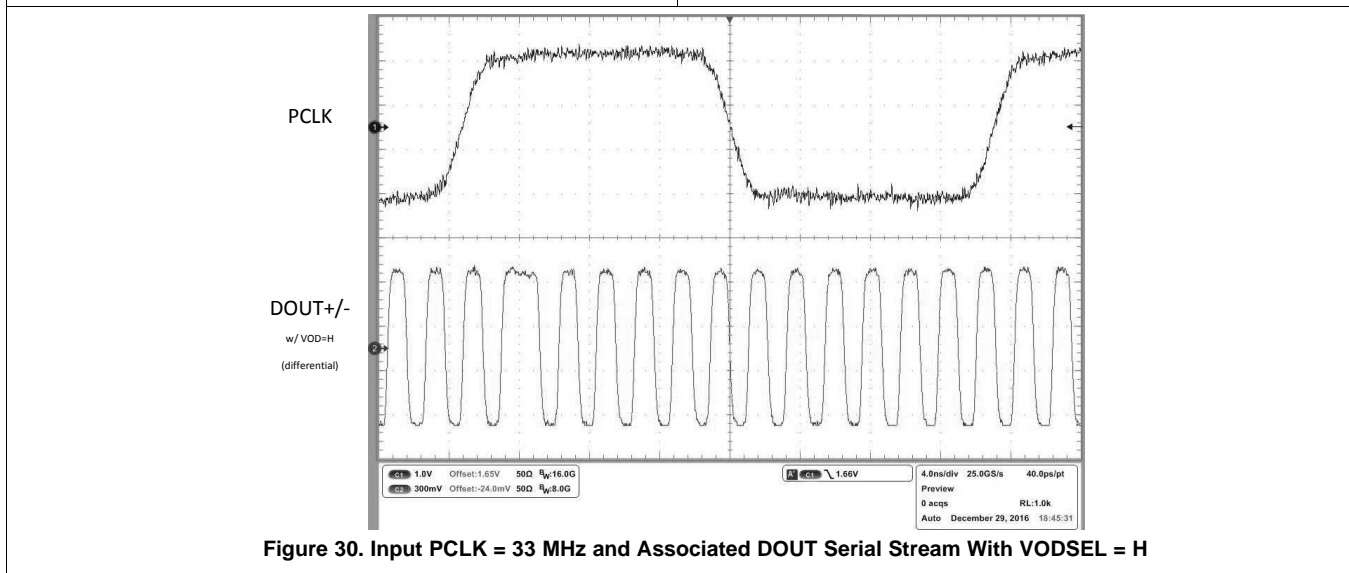

Figure 30. Input PCLK = 33 MHz and Associated DOUT Serial Stream With VODSEL = H

10 Power Supply Recommendations

An all CMOS design of the serializer and deserializer makes them inherently low power devices. Additionally, the constant current source nature of the LVDS outputs minimize the slope of the speed versus I_{CC} curve of CMOS designs.

11 Layout

11.1 Layout Guidelines

Circuit board layout and stack-up for the LVDS SERDES devices must be designed to provide low-noise power feed to the device. Good layout practice also separates high frequency or high-level inputs and outputs to minimize unwanted stray noise pickup, feedback and interference. Power system performance may be greatly improved by using thin dielectrics (2 to 4 mils) for power and ground sandwiches. This arrangement provides plane capacitance for the PCB power system with low-inductance parasitics, which has proven especially effective at high frequencies, and makes the value and placement of external bypass capacitors less critical. External bypass capacitors must include both RF ceramic and tantalum electrolytic types. RF capacitors may use values in the range of 0.01 μF to 0.1 μF . Tantalum capacitors may be in the 2.2- μF to 10- μF range. Voltage rating of the tantalum capacitors must be at least 5 times the power supply voltage being used.

Surface mount capacitors are recommended due to their smaller parasitics. When using multiple capacitors per supply pin, place the smaller value closer to the pin. A large bulk capacitor is recommended at the point of power entry. This is typically in the 50- μF to 100- μF range and smooth low frequency switching noise. TI recommends connecting power and ground pins directly to the power and ground planes with bypass capacitors connected to the plane with via on both ends of the capacitor. Connecting power or ground pins to an external bypass capacitor increases the inductance of the path.

A small body size X7R chip capacitor, such as 0603, is recommended for external bypass. Its small body size reduces the parasitic inductance of the capacitor. The user must pay attention to the resonance frequency of these external bypass capacitors, usually in the range of 20 MHz to 30 MHz range. To provide effective bypassing, multiple capacitors are often used to achieve low impedance between the supply rails over the frequency of interest. At high frequency, it is also a common practice to use two vias from power and ground pins to the planes, reducing the impedance at high frequency.

Some devices provide separate power and ground pins for different portions of the circuit. This is done to isolate switching noise effects between different sections of the circuit. Separate planes on the PCB are typically not required. [Pin Configuration and Functions](#) typically provide guidance on which circuit blocks are connected to which power pin pairs. In some cases, an external filter may be used to provide clean power to sensitive circuits such as PLLs.

Use at least a four layer board with a power and ground plane. Place LVCMOS (LVTTTL) signals away from the LVDS lines to prevent coupling from the LVCMOS lines to the LVDS lines. Closely-coupled differential lines of 100 Ω are typically recommended for LVDS interconnect. The closely coupled lines help to ensure that coupled noise appears as common-mode and thus is rejected by the receivers. The tightly coupled lines also radiate less.

Termination of the LVDS interconnect is required. For point-to-point applications, termination must be placed at both ends of the devices. Nominal value is 100 Ω to match the line's differential impedance. Place the resistor as close to the transmitter DOUT \pm outputs and receiver RIN \pm inputs as possible to minimize the resulting stub between the termination resistor and device.

11.1.1 LVDS Interconnect Guidelines

See [AN-1108 Channel-Link PCB and Interconnect Design-In Guidelines](#) (SNLA008) and [AN-905 Transmission Line RAPIDESIGNER[®] Operation and Applications Guide](#) (SNLA035) for full details.

- Use 100- Ω coupled differential pairs
- Use the S/2S/3S rule in spacings
 - S = space between the pair
 - 2S = space between pairs
 - 3S = space to LVCMOS/LVTTTL signal
- Minimize the number of vias
- Use differential connectors when operating above 500-Mbps line speed
- Maintain balance of the traces
- Minimize skew within the pair
- Terminate as close to the TX outputs and RX inputs as possible

Additional general guidance can be found in the LVDS Owner's Manual available in PDF format from the TI web site at: www.ti.com/lvds.

11.2 Layout Example

Figure 31 shows the input LVCMOS traces and output high-speed, 100-Ω differential traces from the DS90C241 EVM.

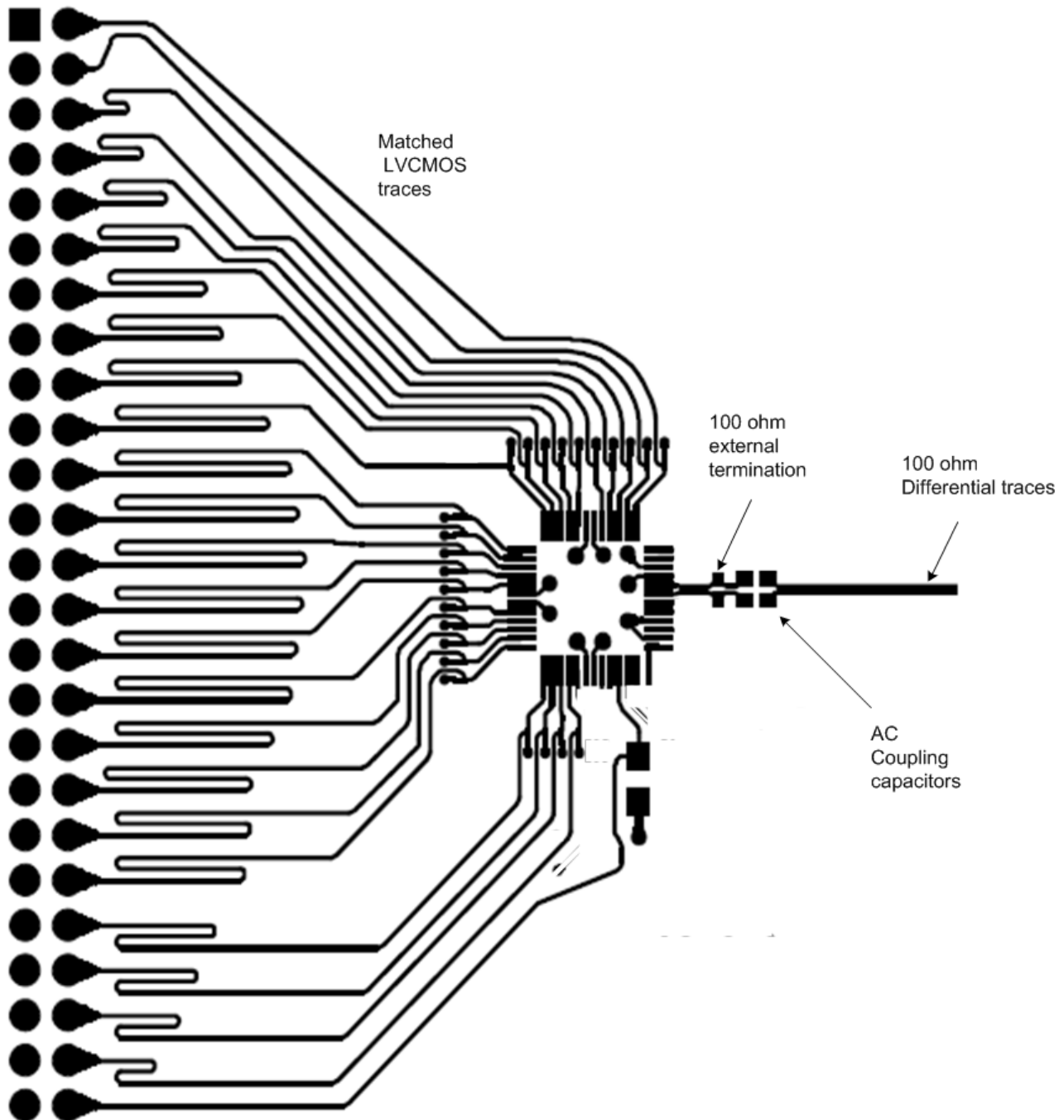

Figure 31. DS90C241 Layout Example from DS90C241 EVM

Layout Example (continued)

Figure 32 shows the input high-speed, 100-Ω differential traces and the output LVCMOS traces and from the DS90C124 EVM.

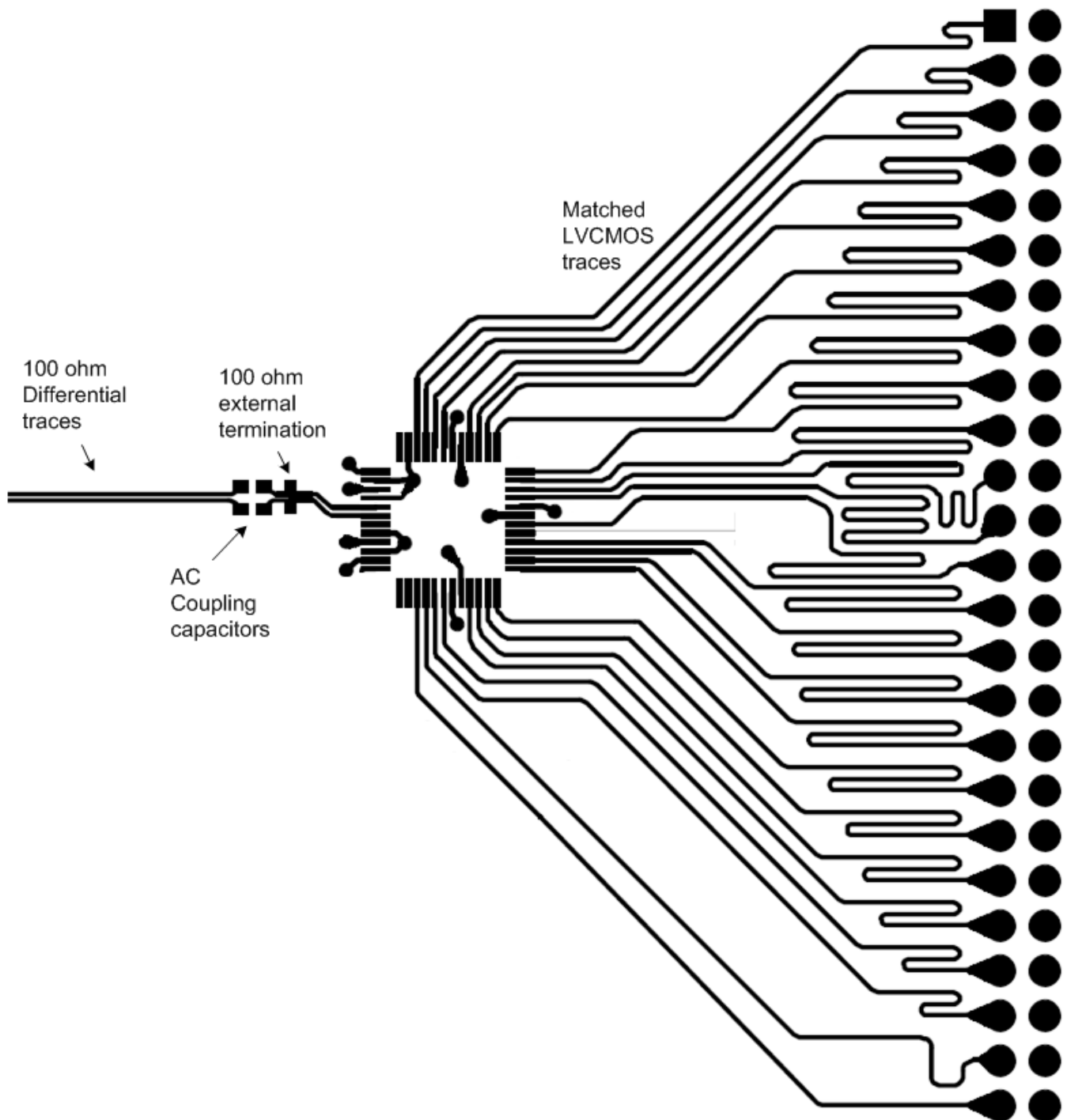

Figure 32. DS90C124 Layout Example from DS90C124 EVM

Layout Example (continued)

Figure 33 shows the power decoupling from the DS90C241 EVM.

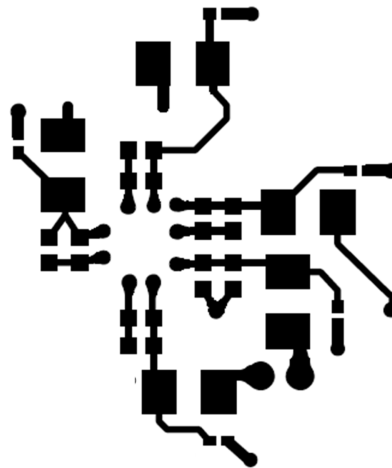

Figure 33. DS90C241 Example Layout of Power Decoupling from EVM

Figure 34 shows the power decoupling from the DS90C124 EVM.

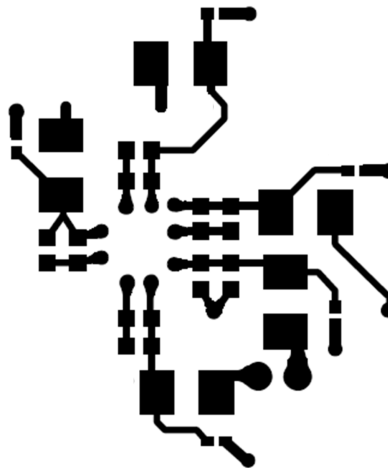

Figure 34. DS90C124 Example Layout of Power Decoupling from EVM

12 Device and Documentation Support

12.1 Documentation Support

12.1.1 Related Documentation

For related documentation see the following:

- [AN-1217 How to Validate BLVDS SER/DES Signal Integrity Using an Eye Mask](#) (SNLA053)
- [AN-1108 Channel-Link PCB and Interconnect Design-In Guidelines](#) (SNLA008)
- [AN-905 Transmission Line RAPIDESIGNER® Operation and Applications Guide](#) (SNLA035)

12.2 Related Links

The table below lists quick access links. Categories include technical documents, support and community resources, tools and software, and quick access to sample or buy.

Table 3. Related Links

PARTS	PRODUCT FOLDER	SAMPLE & BUY	TECHNICAL DOCUMENTS	TOOLS & SOFTWARE	SUPPORT & COMMUNITY
DS90C124	Click here	Click here	Click here	Click here	Click here
DS90C241	Click here	Click here	Click here	Click here	Click here

12.3 Receiving Notification of Documentation Updates

To receive notification of documentation updates, navigate to the device product folder on ti.com. In the upper right corner, click on *Alert me* to register and receive a weekly digest of any product information that has changed. For change details, review the revision history included in any revised document.

12.4 Community Resources

The following links connect to TI community resources. Linked contents are provided "AS IS" by the respective contributors. They do not constitute TI specifications and do not necessarily reflect TI's views; see TI's [Terms of Use](#).

TI E2E™ Online Community *TI's Engineer-to-Engineer (E2E) Community*. Created to foster collaboration among engineers. At e2e.ti.com, you can ask questions, share knowledge, explore ideas and help solve problems with fellow engineers.

Design Support *TI's Design Support* Quickly find helpful E2E forums along with design support tools and contact information for technical support.

12.5 Trademarks

E2E is a trademark of Texas Instruments.
All other trademarks are the property of their respective owners.

12.6 Electrostatic Discharge Caution



These devices have limited built-in ESD protection. The leads should be shorted together or the device placed in conductive foam during storage or handling to prevent electrostatic damage to the MOS gates.

12.7 Glossary

[SLYZ022](#) — *TI Glossary*.

This glossary lists and explains terms, acronyms, and definitions.

13 Mechanical, Packaging, and Orderable Information

The following pages include mechanical, packaging, and orderable information. This information is the most current data available for the designated devices. This data is subject to change without notice and revision of this document. For browser-based versions of this data sheet, refer to the left-hand navigation.

PACKAGING INFORMATION

Orderable part number	Status (1)	Material type (2)	Package Pins	Package qty Carrier	RoHS (3)	Lead finish/ Ball material (4)	MSL rating/ Peak reflow (5)	Op temp (°C)	Part marking (6)
DS90C124IVS/NOPB	Active	Production	TQFP (PFB) 48	250 JEDEC TRAY (10+1)	Yes	SN	Level-3-260C-168 HR	-40 to 105	DS90C124 IVS
DS90C124IVS/NOPB.A	Active	Production	TQFP (PFB) 48	250 JEDEC TRAY (10+1)	Yes	SN	Level-3-260C-168 HR	-40 to 105	DS90C124 IVS
DS90C124IVSX/NOPB	Active	Production	TQFP (PFB) 48	1000 LARGE T&R	Yes	SN	Level-3-260C-168 HR	-40 to 105	DS90C124 IVS
DS90C124IVSX/NOPB.A	Active	Production	TQFP (PFB) 48	1000 LARGE T&R	Yes	SN	Level-3-260C-168 HR	-40 to 105	DS90C124 IVS
DS90C124IVSX/NOPB.B	Active	Production	TQFP (PFB) 48	1000 LARGE T&R	-	Call TI	Call TI	-40 to 105	
DS90C124QVS/NOPB	Active	Production	TQFP (PFB) 48	250 JEDEC TRAY (10+1)	Yes	SN	Level-3-260C-168 HR	-40 to 105	DS90C124 QVS
DS90C124QVS/NOPB.A	Active	Production	TQFP (PFB) 48	250 JEDEC TRAY (10+1)	Yes	SN	Level-3-260C-168 HR	-40 to 105	DS90C124 QVS
DS90C124QVSX/NOPB	Active	Production	TQFP (PFB) 48	1000 LARGE T&R	Yes	SN	Level-3-260C-168 HR	-40 to 105	DS90C124 QVS
DS90C124QVSX/NOPB.A	Active	Production	TQFP (PFB) 48	1000 LARGE T&R	Yes	SN	Level-3-260C-168 HR	-40 to 105	DS90C124 QVS
DS90C124QVSX/NOPB.B	Active	Production	TQFP (PFB) 48	1000 LARGE T&R	-	Call TI	Call TI	-40 to 105	
DS90C241IVS/NOPB	Active	Production	TQFP (PFB) 48	250 EIAJ TRAY (10+1)	Yes	SN	Level-3-260C-168 HR	-40 to 105	DS90C241 IVS
DS90C241IVS/NOPB.A	Active	Production	TQFP (PFB) 48	250 EIAJ TRAY (10+1)	Yes	SN	Level-3-260C-168 HR	-40 to 105	DS90C241 IVS
DS90C241IVSX/NOPB	Active	Production	TQFP (PFB) 48	1000 LARGE T&R	Yes	SN	Level-3-260C-168 HR	-40 to 105	DS90C241 IVS
DS90C241IVSX/NOPB.A	Active	Production	TQFP (PFB) 48	1000 LARGE T&R	Yes	SN	Level-3-260C-168 HR	-40 to 105	DS90C241 IVS
DS90C241IVSX/NOPB.B	Active	Production	TQFP (PFB) 48	1000 LARGE T&R	-	Call TI	Call TI	-40 to 105	
DS90C241QVS/NOPB	Active	Production	TQFP (PFB) 48	250 JEDEC TRAY (10+1)	Yes	SN	Level-3-260C-168 HR	-40 to 105	DS90C241 QVS
DS90C241QVS/NOPB.A	Active	Production	TQFP (PFB) 48	250 JEDEC TRAY (10+1)	Yes	SN	Level-3-260C-168 HR	-40 to 105	DS90C241 QVS
DS90C241QVSX/NOPB	Active	Production	TQFP (PFB) 48	1000 LARGE T&R	Yes	SN	Level-3-260C-168 HR	-40 to 105	DS90C241 QVS

Orderable part number	Status (1)	Material type (2)	Package Pins	Package qty Carrier	RoHS (3)	Lead finish/ Ball material (4)	MSL rating/ Peak reflow (5)	Op temp (°C)	Part marking (6)
DS90C241QVSX/NOPB.A	Active	Production	TQFP (PFB) 48	1000 LARGE T&R	Yes	SN	Level-3-260C-168 HR	-40 to 105	DS90C241 QVS
DS90C241QVSX/NOPB.B	Active	Production	TQFP (PFB) 48	1000 LARGE T&R	-	Call TI	Call TI	-40 to 105	

⁽¹⁾ **Status:** For more details on status, see our [product life cycle](#).

⁽²⁾ **Material type:** When designated, preproduction parts are prototypes/experimental devices, and are not yet approved or released for full production. Testing and final process, including without limitation quality assurance, reliability performance testing, and/or process qualification, may not yet be complete, and this item is subject to further changes or possible discontinuation. If available for ordering, purchases will be subject to an additional waiver at checkout, and are intended for early internal evaluation purposes only. These items are sold without warranties of any kind.

⁽³⁾ **RoHS values:** Yes, No, RoHS Exempt. See the [TI RoHS Statement](#) for additional information and value definition.

⁽⁴⁾ **Lead finish/Ball material:** Parts may have multiple material finish options. Finish options are separated by a vertical ruled line. Lead finish/Ball material values may wrap to two lines if the finish value exceeds the maximum column width.

⁽⁵⁾ **MSL rating/Peak reflow:** The moisture sensitivity level ratings and peak solder (reflow) temperatures. In the event that a part has multiple moisture sensitivity ratings, only the lowest level per JEDEC standards is shown. Refer to the shipping label for the actual reflow temperature that will be used to mount the part to the printed circuit board.

⁽⁶⁾ **Part marking:** There may be an additional marking, which relates to the logo, the lot trace code information, or the environmental category of the part.

Multiple part markings will be inside parentheses. Only one part marking contained in parentheses and separated by a "~" will appear on a part. If a line is indented then it is a continuation of the previous line and the two combined represent the entire part marking for that device.

Important Information and Disclaimer: The information provided on this page represents TI's knowledge and belief as of the date that it is provided. TI bases its knowledge and belief on information provided by third parties, and makes no representation or warranty as to the accuracy of such information. Efforts are underway to better integrate information from third parties. TI has taken and continues to take reasonable steps to provide representative and accurate information but may not have conducted destructive testing or chemical analysis on incoming materials and chemicals. TI and TI suppliers consider certain information to be proprietary, and thus CAS numbers and other limited information may not be available for release.

In no event shall TI's liability arising out of such information exceed the total purchase price of the TI part(s) at issue in this document sold by TI to Customer on an annual basis.

OTHER QUALIFIED VERSIONS OF DS90C124, DS90C124-Q1, DS90C241, DS90C241-Q1 :

● Catalog : [DS90C124](#), [DS90C241](#)

● Automotive : [DS90C124-Q1](#), [DS90C241-Q1](#)

NOTE: Qualified Version Definitions:

- Catalog - TI's standard catalog product
- Automotive - Q100 devices qualified for high-reliability automotive applications targeting zero defects

TAPE AND REEL INFORMATION

QUADRANT ASSIGNMENTS FOR PIN 1 ORIENTATION IN TAPE

*All dimensions are nominal

Device	Package Type	Package Drawing	Pins	SPQ	Reel Diameter (mm)	Reel Width W1 (mm)	A0 (mm)	B0 (mm)	K0 (mm)	P1 (mm)	W (mm)	Pin1 Quadrant
DS90C124IVSX/NOPB	TQFP	PFB	48	1000	330.0	16.4	9.8	9.8	2.0	12.0	16.0	Q2
DS90C124QVSX/NOPB	TQFP	PFB	48	1000	330.0	16.4	9.8	9.8	2.0	12.0	16.0	Q2
DS90C241IVSX/NOPB	TQFP	PFB	48	1000	330.0	16.4	9.8	9.8	2.0	12.0	16.0	Q2
DS90C241QVSX/NOPB	TQFP	PFB	48	1000	330.0	16.4	9.8	9.8	2.0	12.0	16.0	Q2

TAPE AND REEL BOX DIMENSIONS



*All dimensions are nominal

Device	Package Type	Package Drawing	Pins	SPQ	Length (mm)	Width (mm)	Height (mm)
DS90C124IVSX/NOPB	TQFP	PFB	48	1000	356.0	356.0	36.0
DS90C124QVSX/NOPB	TQFP	PFB	48	1000	356.0	356.0	36.0
DS90C241IVSX/NOPB	TQFP	PFB	48	1000	356.0	356.0	36.0
DS90C241QVSX/NOPB	TQFP	PFB	48	1000	356.0	356.0	36.0

TRAY

Chamfer on Tray corner indicates Pin 1 orientation of packed units.

*All dimensions are nominal

Device	Package Name	Package Type	Pins	SPQ	Unit array matrix	Max temperature (°C)	L (mm)	W (mm)	K0 (µm)	P1 (mm)	CL (mm)	CW (mm)
DS90C124IVS/NOPB	PFB	TQFP	48	250	10 x 25	150	315	135.9	7620	12.2	11.1	11.25
DS90C124IVS/NOPB.A	PFB	TQFP	48	250	10 x 25	150	315	135.9	7620	12.2	11.1	11.25
DS90C124QVS/NOPB	PFB	TQFP	48	250	10 x 25	150	315	135.9	7620	12.2	11.1	11.25
DS90C124QVS/NOPB.A	PFB	TQFP	48	250	10 x 25	150	315	135.9	7620	12.2	11.1	11.25
DS90C241IVS/NOPB	PFB	TQFP	48	250	10 x 25	150	315	135.9	7620	12.2	11.1	11.25
DS90C241IVS/NOPB.A	PFB	TQFP	48	250	10 x 25	150	315	135.9	7620	12.2	11.1	11.25
DS90C241QVS/NOPB	PFB	TQFP	48	250	10 x 25	150	315	135.9	7620	12.2	11.1	11.25
DS90C241QVS/NOPB.A	PFB	TQFP	48	250	10 x 25	150	315	135.9	7620	12.2	11.1	11.25

PFB0048A

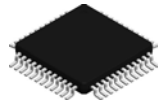

PACKAGE OUTLINE

TQFP - 1.2 mm max height

PLASTIC QUAD FLATPACK

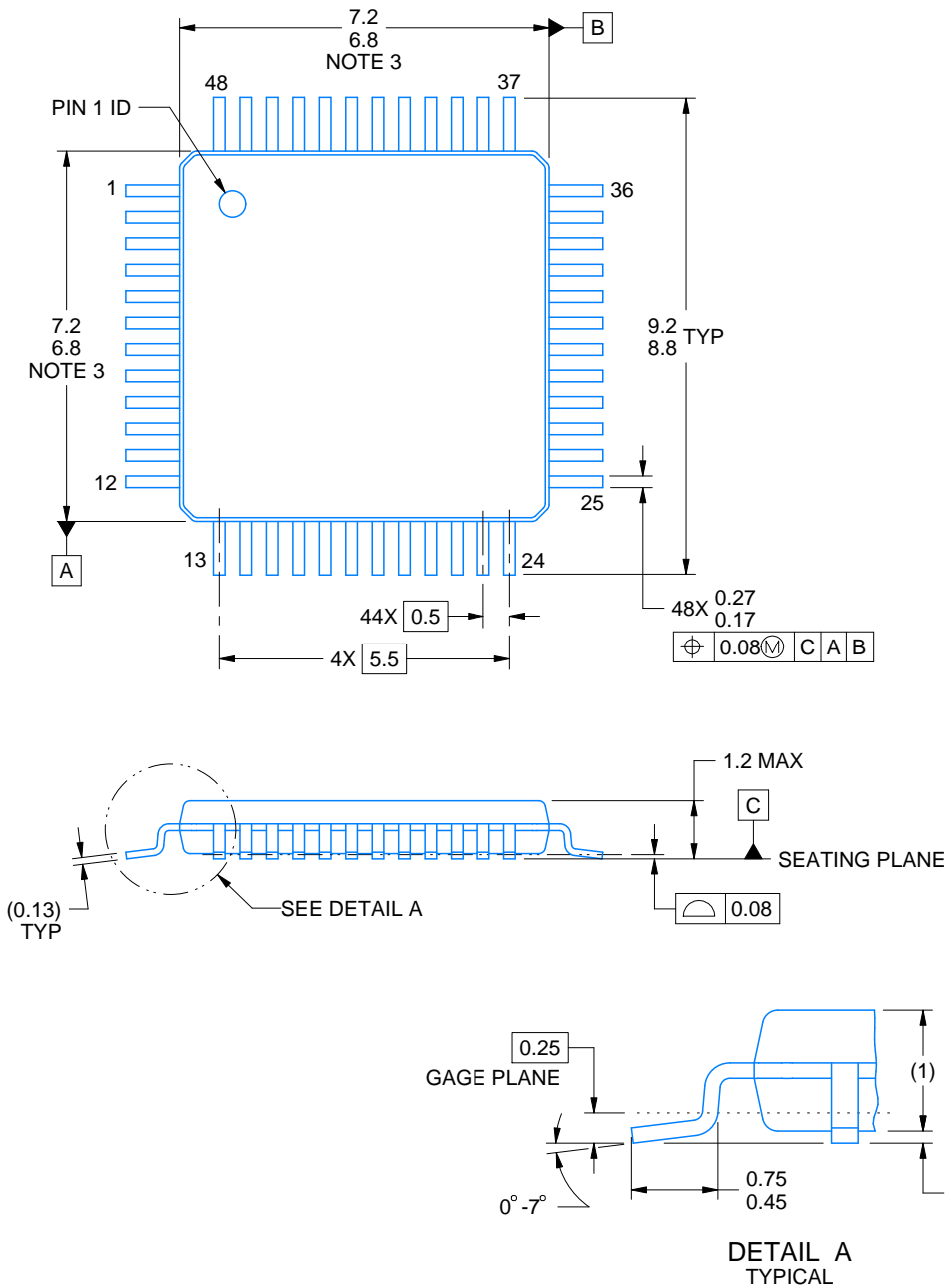

4215157/A 03/2024

NOTES:

1. All linear dimensions are in millimeters. Any dimensions in parenthesis are for reference only. Dimensioning and tolerancing per ASME Y14.5M.
2. This drawing is subject to change without notice.
3. Reference JEDEC registration MS-026.

EXAMPLE BOARD LAYOUT

PFB0048A

TQFP - 1.2 mm max height

PLASTIC QUAD FLATPACK

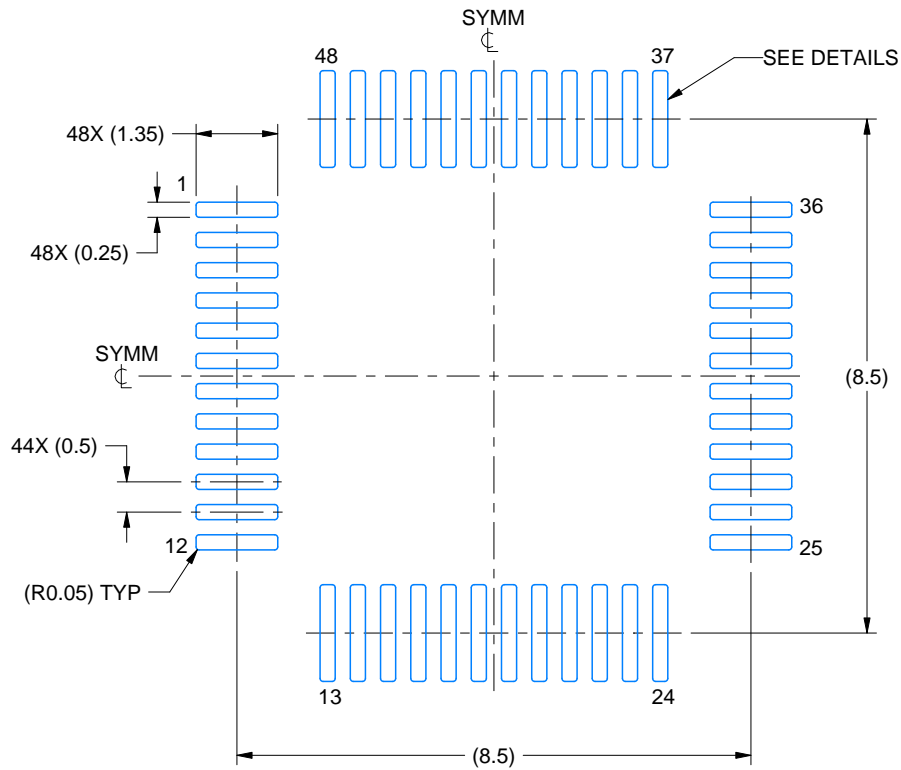

LAND PATTERN EXAMPLE
EXPOSED METAL SHOWN
SCALE:8X

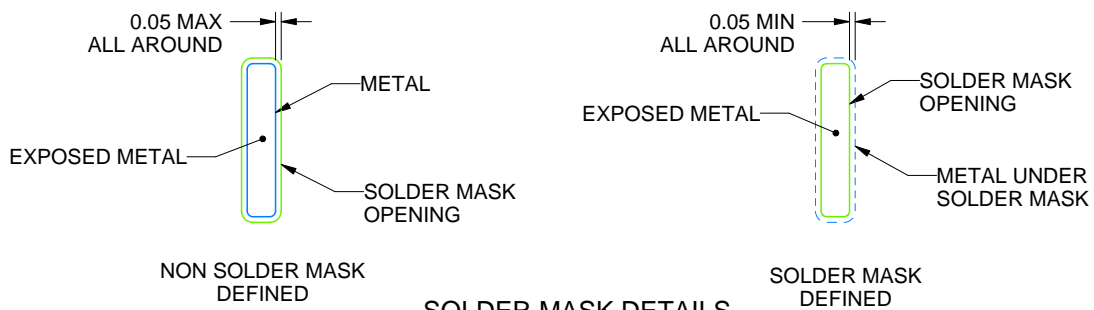

SOLDER MASK DETAILS

4215157/A 03/2024

NOTES: (continued)

4. Publication IPC-7351 may have alternate designs.
5. Solder mask tolerances between and around signal pads can vary based on board fabrication site.

EXAMPLE STENCIL DESIGN

PFB0048A

TQFP - 1.2 mm max height

PLASTIC QUAD FLATPACK

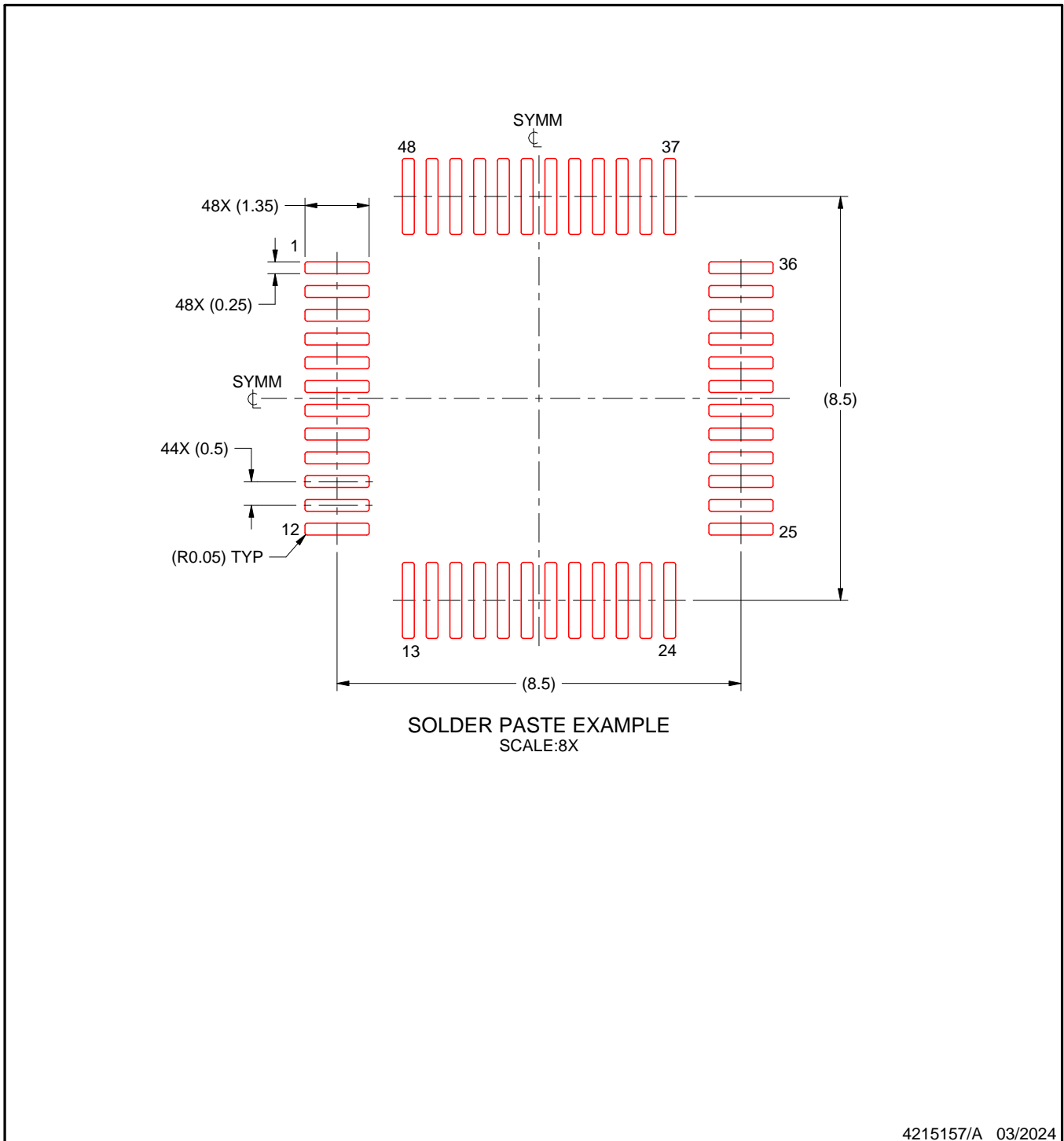

NOTES: (continued)

6. Laser cutting apertures with trapezoidal walls and rounded corners may offer better paste release. IPC-7525 may have alternate design recommendations.
7. Board assembly site may have different recommendations for stencil design.

IMPORTANT NOTICE AND DISCLAIMER

TI PROVIDES TECHNICAL AND RELIABILITY DATA (INCLUDING DATASHEETS), DESIGN RESOURCES (INCLUDING REFERENCE DESIGNS), APPLICATION OR OTHER DESIGN ADVICE, WEB TOOLS, SAFETY INFORMATION, AND OTHER RESOURCES "AS IS" AND WITH ALL FAULTS, AND DISCLAIMS ALL WARRANTIES, EXPRESS AND IMPLIED, INCLUDING WITHOUT LIMITATION ANY IMPLIED WARRANTIES OF MERCHANTABILITY, FITNESS FOR A PARTICULAR PURPOSE OR NON-INFRINGEMENT OF THIRD PARTY INTELLECTUAL PROPERTY RIGHTS.

These resources are intended for skilled developers designing with TI products. You are solely responsible for (1) selecting the appropriate TI products for your application, (2) designing, validating and testing your application, and (3) ensuring your application meets applicable standards, and any other safety, security, regulatory or other requirements.

These resources are subject to change without notice. TI grants you permission to use these resources only for development of an application that uses the TI products described in the resource. Other reproduction and display of these resources is prohibited. No license is granted to any other TI intellectual property right or to any third party intellectual property right. TI disclaims responsibility for, and you fully indemnify TI and its representatives against any claims, damages, costs, losses, and liabilities arising out of your use of these resources.

TI's products are provided subject to [TI's Terms of Sale](#), [TI's General Quality Guidelines](#), or other applicable terms available either on [ti.com](#) or provided in conjunction with such TI products. TI's provision of these resources does not expand or otherwise alter TI's applicable warranties or warranty disclaimers for TI products. Unless TI explicitly designates a product as custom or customer-specified, TI products are standard, catalog, general purpose devices.

TI objects to and rejects any additional or different terms you may propose.

Copyright © 2025, Texas Instruments Incorporated

Last updated 10/2025