



24-BIT, 192-kHz SAMPLING, ADVANCED SEGMENT, AUDIO STEREO DIGITAL-TO-ANALOG CONVERTER

FEATURES

- Supports both DSD and PCM Formats
- 24-Bit Resolution
- Analog Performance:
 - Dynamic Range: 113 dB
 - THD+N: 0.001%
 - Full-Scale Output: 2.1 V RMS (at Postamp)
- Differential Voltage Output: 3.2 V_{p-p}
- 8× Oversampling Digital Filter:
 - Stop-Band Attenuation: –82 dB
 - Pass-Band Ripple: ±0.002 dB
- Sampling Frequency: 10 kHz to 200 kHz
- System Clock: 128, 192, 256, 384, 512, or 768 f_s With Autodetect
- Accepts 16-, 20-, and 24-Bit PCM Audio Data
- PCM Data Formats: Standard, I²S, and Left-Justified
- DSD Format Interface Available
- Optional Interface to External Digital Filter or DSP Available
- TDMCA Interface Available
- User-Programmable Mode Controls:
 - Digital Attenuation: 0 dB to –120 dB, 0.5 dB/Step
 - Digital De-Emphasis
 - Digital Filter Rolloff: Sharp or Slow
 - Soft Mute
 - Zero Flag for Each Output/PCM and DSD Formats

- Dual Supply Operation:
 - 5-V Analog, 3.3-V Digital
- 5-V Tolerant Digital Inputs
- Small 28-Lead SSOP Package

APPLICATIONS

- A/V Receivers
- SACD Players
- DVD Players
- HDTV Receivers
- Car Audio Systems
- Digital Multitrack Recorders
- Other Applications Requiring 24-Bit Audio

DESCRIPTION

The DSD1791 is a monolithic CMOS integrated circuit that includes stereo digital-to-analog converters and support circuitry in a small 28-lead SSOP package. The data converters use TI's advanced segment DAC architecture to achieve excellent dynamic performance and improved tolerance to clock jitter. The DSD1791 provides balanced voltage outputs, allowing the user to optimize analog performance externally. The DSD1791 accepts PCM and DSD audio data formats, providing easy interfacing to audio DSP and decoder chips. The DSD1791 also accepts interface to external digital filter devices (DF1704, DF1706, PMD200). Sampling rates up to 200 kHz are supported. A full set of user-programmable functions is accessible through an SPI control port, which supports register write and readback functions. The DSD1791 also supports the time-division-multiplexed command and audio (TDMCA) data format.



This integrated circuit can be damaged by ESD. Texas Instruments recommends that all integrated circuits be handled with appropriate precautions. Failure to observe proper handling and installation procedures can cause damage.

ESD damage can range from subtle performance degradation to complete device failure. Precision integrated circuits may be more susceptible to damage because very small parametric changes could cause the device not to meet its published specifications.



Please be aware that an important notice concerning availability, standard warranty, and use in critical applications of Texas Instruments semiconductor products and disclaimers thereto appears at the end of this data sheet.

ORDERING INFORMATION

PRODUCT	PACKAGE	PACKAGE CODE	OPERATION TEMPERATURE RANGE	PACKAGE MARKING	ORDERING NUMBER	TRANSPORT MEDIA
DSD1791DB	28-lead SSOP	28DB	–25°C to 85°C	DSD1791	DSD1791DB	Tube
					DSD1791DBR	Tape and reel

ABSOLUTE MAXIMUM RATINGSover operating free-air temperature range unless otherwise noted⁽¹⁾

		DSD1791
Supply voltage	V _{CCF} , V _{CCL} , V _{CCC} , V _{CCR}	–0.3 V to 6.5 V
	V _{DD}	–0.3 V to 4 V
Supply voltage differences: V _{CCF} , V _{CCL} , V _{CCC} , V _{CCR}		±0.1 V
Ground voltage differences: AGNDF, AGNDL, AGNDC, AGNDR, DGND		±0.1 V
Digital input voltage	PLRCK, PDATA, PBCK, DSDL, DSDR, DBCK, MS ⁽²⁾ , MDI ⁽²⁾ , MC, SCK, RST	–0.3 V to 6.5 V
	ZEROL, ZEROR, MS ⁽³⁾ , MDI ⁽³⁾	–0.3 V to (V _{DD} + 0.3 V) < 4 V
Analog input voltage		–0.3 V to (V _{CC} + 0.3 V) < 6.5 V
Input current (any pins except supplies)		±10 mA
Ambient temperature under bias		–40°C to 125°C
Storage temperature		–55°C to 150°C
Junction temperature		150°C
Lead temperature (soldering)		260°C, 5 s
Package temperature (IR reflow, peak)		260°C

(1) Stresses beyond those listed under “absolute maximum ratings” may cause permanent damage to the device. These are stress ratings only, and functional operation of the device at these or any other conditions beyond those indicated under “recommended operating conditions” is not implied. Exposure to absolute-maximum-rated conditions for extended periods may affect device reliability.

(2) Input mode

(3) Output mode

ELECTRICAL CHARACTERISTICSall specifications at T_A = 25°C, V_{CC} = 5 V, V_{DD} = 3.3 V, f_S = 44.1 kHz, system clock = 256 f_S, and 24-bit data, unless otherwise noted

PARAMETER	DSD1791DB			UNIT
	MIN	TYP	MAX	
RESOLUTION	24			Bits
DATA FORMAT (PCM Mode)				
Audio data interface format	Standard, I ² S, left justified			
Audio data bit length	16-, 20-, 24-bit selectable			
Audio data format	MSB first, 2s complement			
f _S Sampling frequency	10		200	kHz
System clock frequency	128, 192, 256, 384, 512, 768 f _S			
DATA FORMAT (DSD Mode)				
Audio data interface format	DSD (direct stream digital)			
Audio data bit length	1 Bit			
f _S Sampling frequency	2.8224			MHz
System clock frequency	2.8224		11.2896	MHz

ELECTRICAL CHARACTERISTICS (Continued)

 all specifications at $T_A = 25^\circ\text{C}$, $V_{CC} = 5\text{ V}$, $V_{DD} = 3.3\text{ V}$, $f_S = 44.1\text{ kHz}$, system clock = $256 f_S$, and 24-bit data, unless otherwise noted

PARAMETER	TEST CONDITIONS	DSD1791DB			UNIT
		MIN	TYP	MAX	
DIGITAL INPUT/OUTPUT					
Logic family		TTL compatible			
V_{IH}	Input logic level	2			VDC
V_{IL}		0.8			
I_{IH}	Input logic current	$V_{IN} = V_{DD}$	10		μA
I_{IL}		$V_{IN} = 0\text{ V}$	-10		
V_{OH}	Output logic level	$I_{OH} = -2\text{ mA}$	2.4		VDC
V_{OL}		$I_{OL} = 2\text{ mA}$	0.4		
DYNAMIC PERFORMANCE (PCM MODE) (1)					
THD+N at $V_{OUT} = 0\text{ dB}$	$f_S = 44.1\text{ kHz}$	0.001%	0.002%		
	$f_S = 96\text{ kHz}$	0.0015%			
	$f_S = 192\text{ kHz}$	0.003%			
Dynamic range	EIAJ, A-weighted, $f_S = 44.1\text{ kHz}$	110	113		dB
	EIAJ, A-weighted, $f_S = 96\text{ kHz}$	113			
	EIAJ, A-weighted, $f_S = 192\text{ kHz}$	113			
Signal-to-noise ratio	EIAJ, A-weighted, $f_S = 44.1\text{ kHz}$	110	113		dB
	EIAJ, A-weighted, $f_S = 96\text{ kHz}$	113			
	EIAJ, A-weighted, $f_S = 192\text{ kHz}$	113			
Channel separation	$f_S = 44.1\text{ kHz}$	106	110		dB
	$f_S = 96\text{ kHz}$	110			
	$f_S = 192\text{ kHz}$	109			
Level linearity error	$V_{OUT} = -120\text{ dB}$	± 1			dB
DYNAMIC PERFORMANCE (DSD MODE) (1) (2)					
THD+N at $V_{OUT} = 0\text{ dB}$	2.1 V rms	0.001%			
Dynamic range	-60 dB, EIAJ, A-weighted	113			dB
Signal-to-noise ratio	EIAJ, A-weighted	113			dB
ANALOG OUTPUT					
Gain error		-8	± 3	8	% of FSR
Gain mismatch, channel-to-channel		-3	± 0.5	3	% of FSR
Bipolar zero error	At BPZ	-2	± 0.5	2	% of FSR
Differential output voltage (3)	Full scale (0 dB)	3.2			V p-p
Bipolar zero voltage (3)	At BPZ	1.4			V
Load impedance (3)	$R_1 = R_2$	1.7			k Ω

(1) Dynamic performance and dc accuracy are specified at the output of the postamplifier as shown in Figure 33. Analog performance specifications are measured using the System Two™ Cascade audio measurement system by Audio Precision™ in the averaging mode. For all sampling-frequency operations, measurement bandwidth is limited with a 20-kHz AES17 filter.

(2) Analog performance in the DSD mode is specified as the DSD modulation index of 100%. This is equivalent to PCM mode performance at 44.1 kHz and $64 f_S$.

(3) These parameters are defined at the DSD1791 output pins. Load impedances, R_1 and R_2 , are input resistors of the postamplifier. They are defined as dc loads.

ELECTRICAL CHARACTERISTICS (Continued)all specifications at $T_A = 25^\circ\text{C}$, $V_{CC} = 5\text{ V}$, $V_{DD} = 3.3\text{ V}$, $f_S = 44.1\text{ kHz}$, system clock = $256 f_S$, and 24-bit data, unless otherwise noted

PARAMETER	TEST CONDITIONS	DSD1791DB			UNIT		
		MIN	TYP	MAX			
DIGITAL FILTER PERFORMANCE							
De-emphasis error				± 0.1	dB		
FILTER CHARACTERISTICS-1: SHARP ROLLOFF							
Pass band	$\pm 0.002\text{ dB}$			$0.454 f_S$			
	-3 dB			$0.49 f_S$			
Stop band				$0.546 f_S$			
Pass-band ripple				± 0.002	dB		
Stop-band attenuation	Stop band = $0.546 f_S$			-75	dB		
	Stop band = $0.567 f_S$			-82			
Delay time				$29/f_S$	s		
FILTER CHARACTERISTICS-2: SLOW ROLLOFF							
Pass band	$\pm 0.04\text{ dB}$			$0.274 f_S$			
	-3 dB			$0.454 f_S$			
Stop band				$0.732 f_S$			
Pass-band ripple				± 0.002	dB		
Stop-band attenuation	Stop band = $0.732 f_S$			-82	dB		
Delay time				$29/f_S$	s		
POWER SUPPLY REQUIREMENTS							
V_{DD}	Voltage range			3	3.3	3.6	VDC
V_{CC}				4.5	5	5.5	VDC
I_{DD}	Supply current (1)	$f_S = 44.1\text{ kHz}$			6.5	8	mA
		$f_S = 96\text{ kHz}$			13.5		
		$f_S = 192\text{ kHz}$			28		
I_{CC}	Supply current (1)	$f_S = 44.1\text{ kHz}$			14	16	mA
		$f_S = 96\text{ kHz}$			15		
		$f_S = 192\text{ kHz}$			16		
Power dissipation (1)		$f_S = 44.1\text{ kHz}$			90	110	mW
		$f_S = 96\text{ kHz}$			120		
		$f_S = 192\text{ kHz}$			170		
TEMPERATURE RANGE							
Operation temperature				-25		85	$^\circ\text{C}$
θ_{JA}	Thermal resistance	28-pin SSOP			100		$^\circ\text{C/W}$

(1) Input is BPZ data.

PIN ASSIGNMENTS

**DSD1791
(TOP VIEW)**

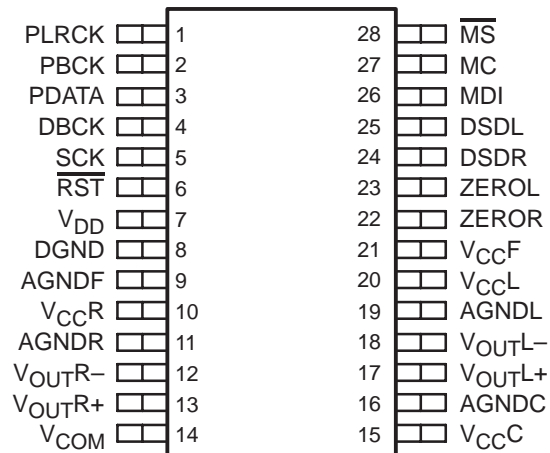

Terminal Functions

TERMINAL NAME	PIN	I/O	DESCRIPTIONS
AGNDC	16	–	Analog ground (internal bias and current DAC)
AGNDF	9	–	Analog ground (DACFF)
AGNDL	19	–	Analog ground (L-channel I/V)
AGNDR	11	–	Analog ground (R-channel I/V)
DBCK	4	I	Bit clock input for DSD mode (1)
DGND	8	–	Digital ground
DSDL	25	I	L-channel audio data input for DSD mode (1)
DSDR	24	I	R-channel audio data input for DSD mode (1)
MC	27	I	Mode control clock input (1)
MDI	26	I/O	Mode control data input (2)
$\overline{\text{MS}}$	28	I/O	Mode control chip select input (2)
PBCK	2	I	Bit clock input for PCM mode (1)
PDATA	3	I	Serial audio data input for PCM mode (1)
PLRCK	1	I	Left and right clock (f_S) input for PCM mode (1)
$\overline{\text{RST}}$	6	I	Reset (1)
SCK	5	I	System clock input (1)
VCC	15	–	Analog power supply (internal bias and current DAC), 5 V
VCCF	21	–	Analog power supply (DACFF), 5 V
VCCL	20	–	Analog power supply (L-channel I/V), 5 V
VCCR	10	–	Analog power supply (R-channel I/V), 5 V
VCOM	14	–	Internal bias decoupling pin
VDD	7	–	Digital power supply, 3.3 V
VO _{UTL+}	17	O	L-channel analog voltage output +
VO _{UTL-}	18	O	L-channel analog voltage output –
VO _{UTR+}	13	O	R-channel analog voltage output +
VO _{UTR-}	12	O	R-channel analog voltage output –
ZEROL	23	O	Zero flag for L-channel
ZEROR	22	O	Zero flag for R-channel

(1) Schmitt-trigger input, 5-V tolerant

(2) Schmitt-trigger input and output. 5-V tolerant input and CMOS output.

FUNCTIONAL BLOCK DIAGRAM

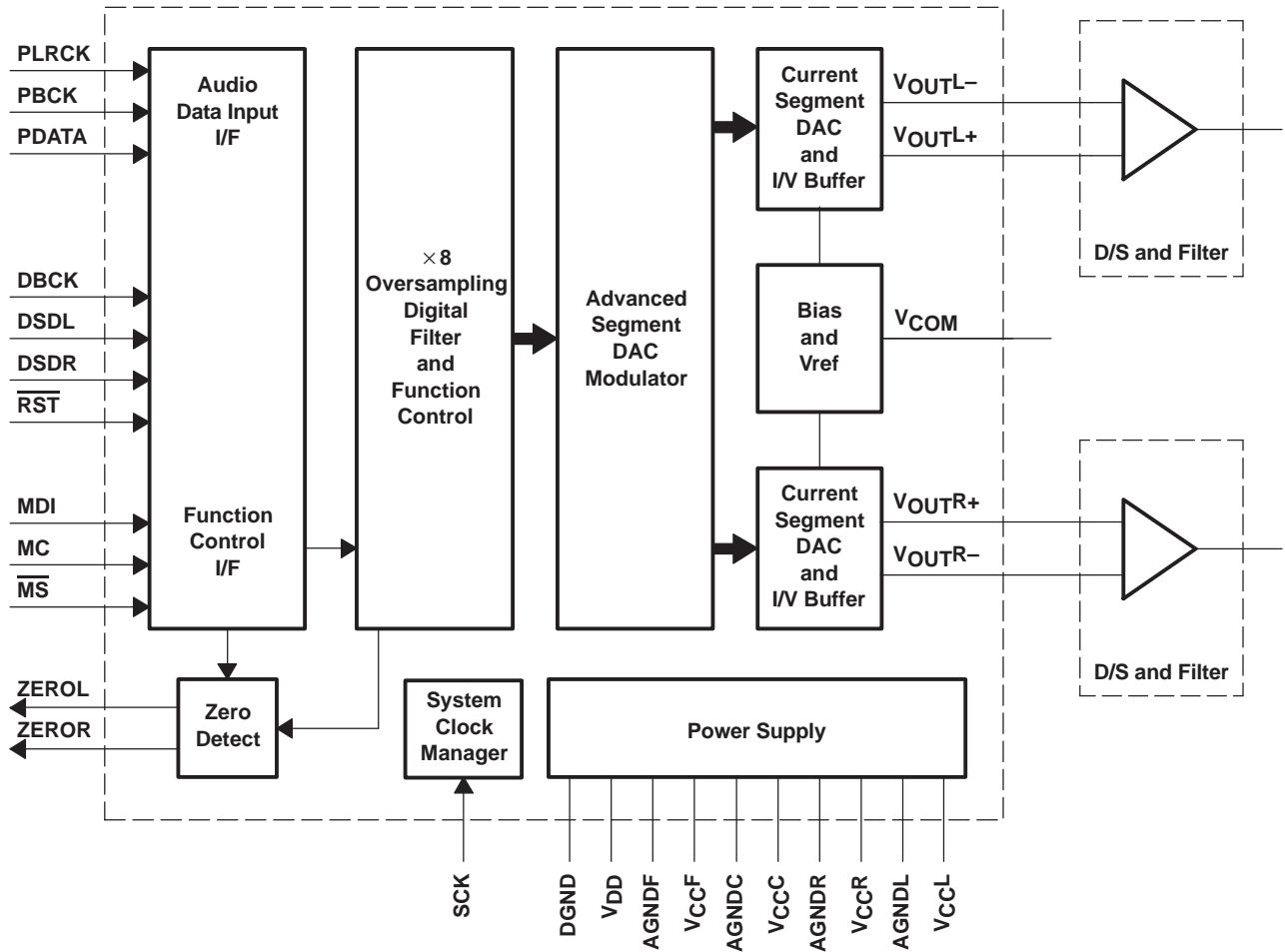

TYPICAL PERFORMANCE CURVES

DIGITAL FILTER

Digital Filter Response

AMPLITUDE
VS
FREQUENCY

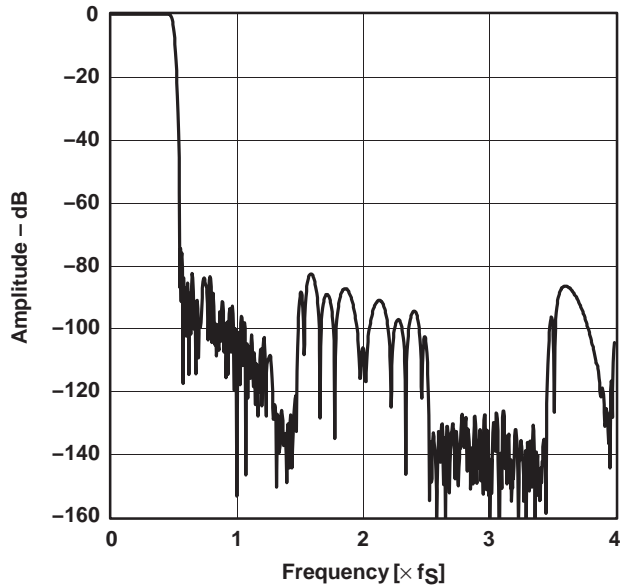

Figure 1. Frequency Response, Sharp Rolloff

AMPLITUDE
VS
FREQUENCY

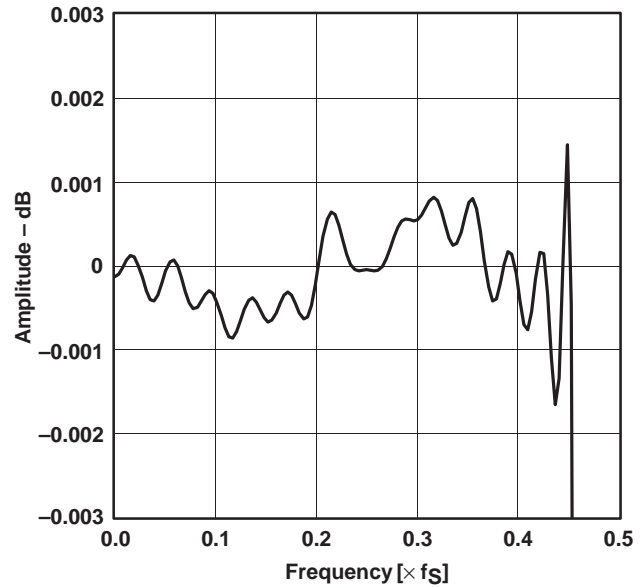

Figure 2. Pass-Band Ripple, Sharp Rolloff

AMPLITUDE
VS
FREQUENCY

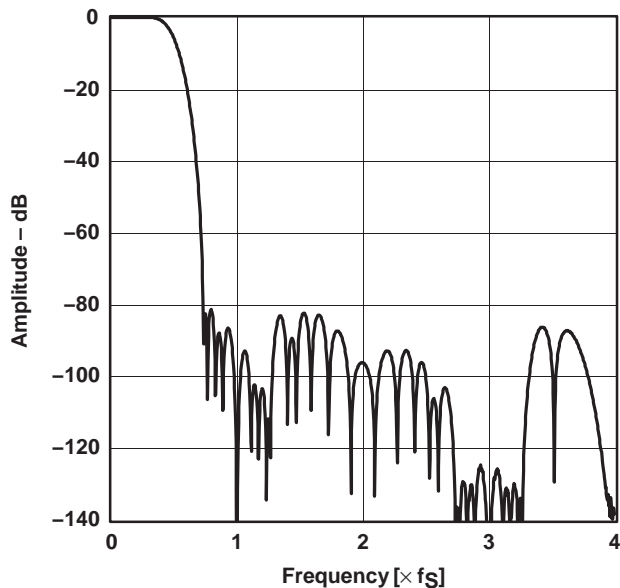

Figure 3. Frequency Response, Slow Rolloff

AMPLITUDE
VS
FREQUENCY

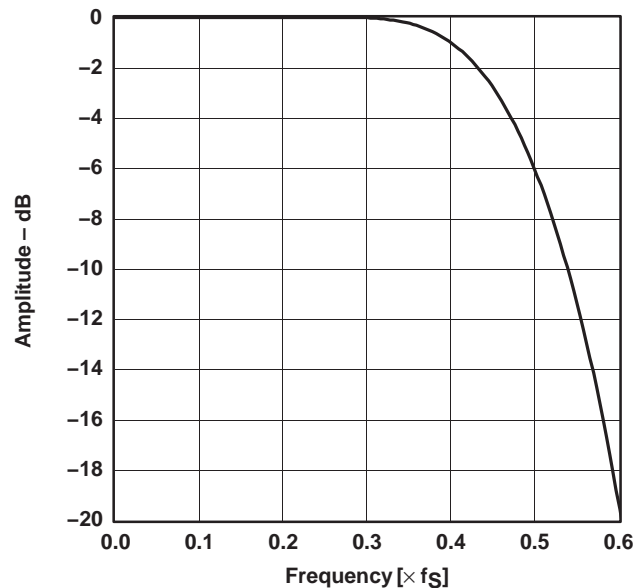

Figure 4. Transition Characteristics, Slow Rolloff

De-Emphasis Filter

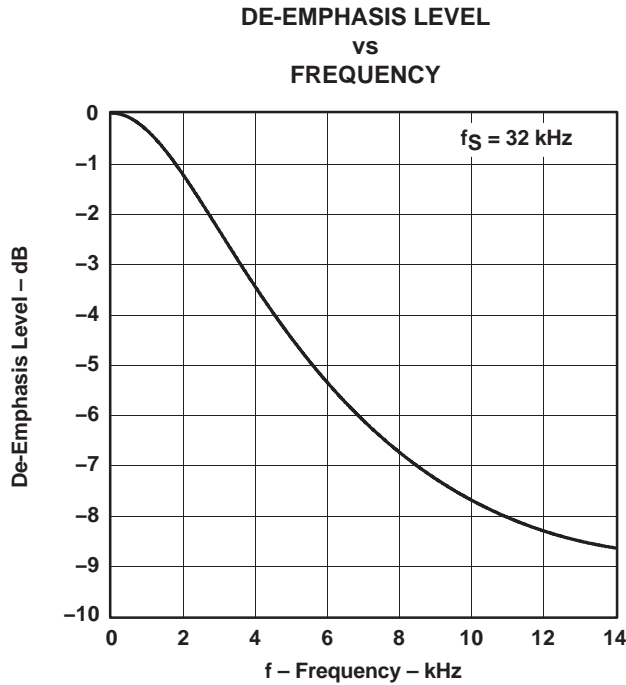

Figure 5

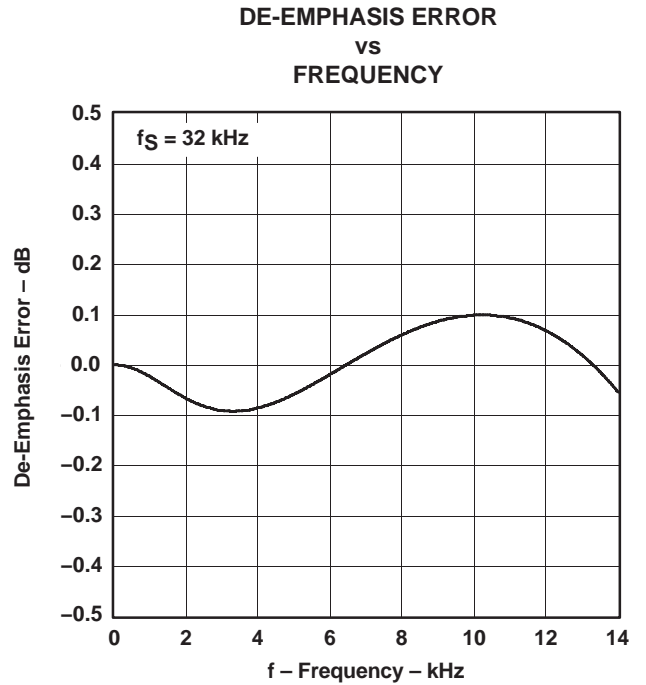

Figure 6

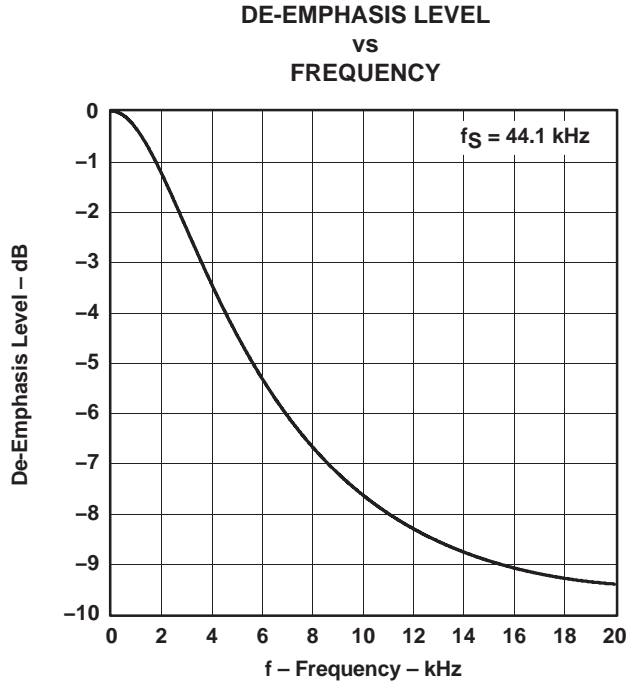

Figure 7

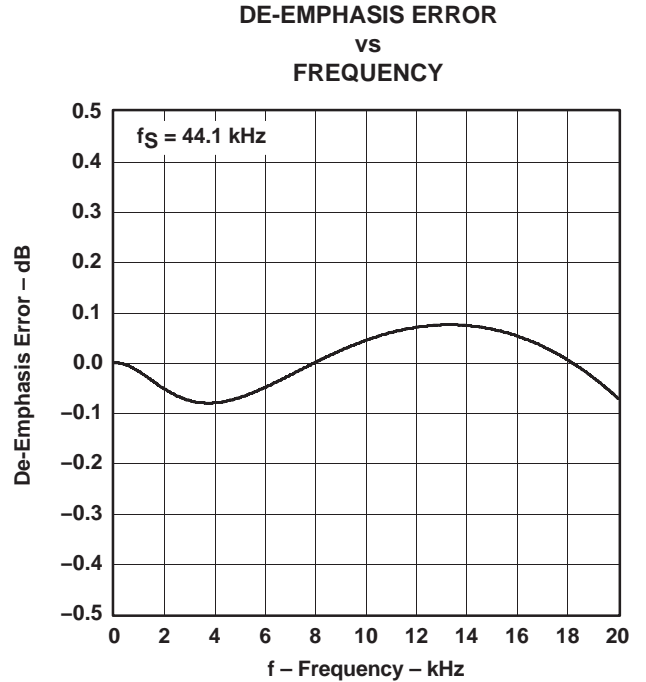

Figure 8

De-Emphasis Filter (Continued)

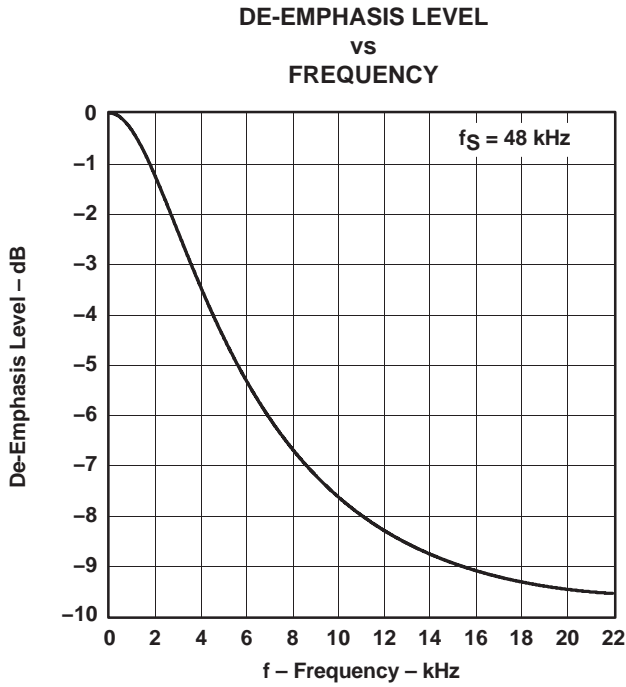

Figure 9

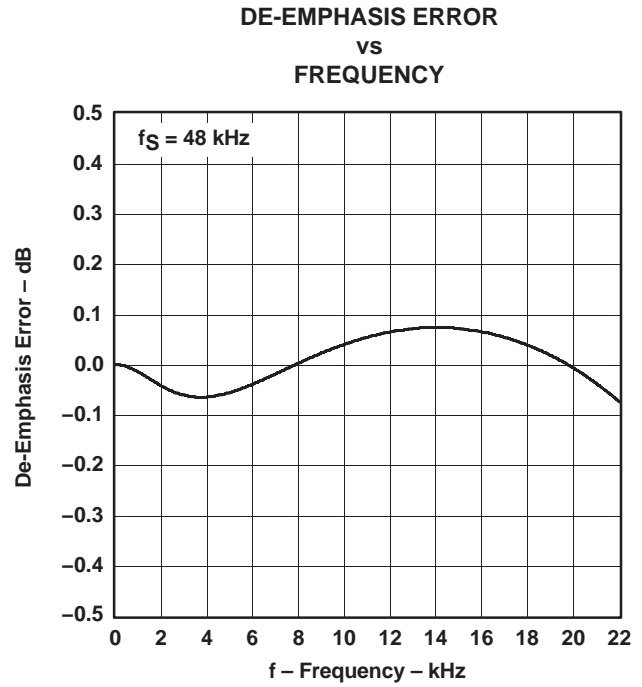

Figure 10

ANALOG DYNAMIC PERFORMANCE

Supply Voltage Characteristics

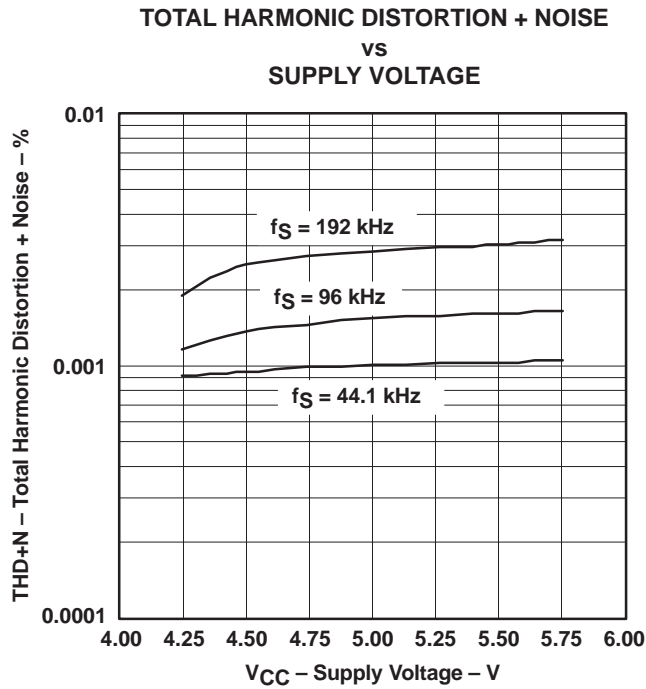

Figure 11

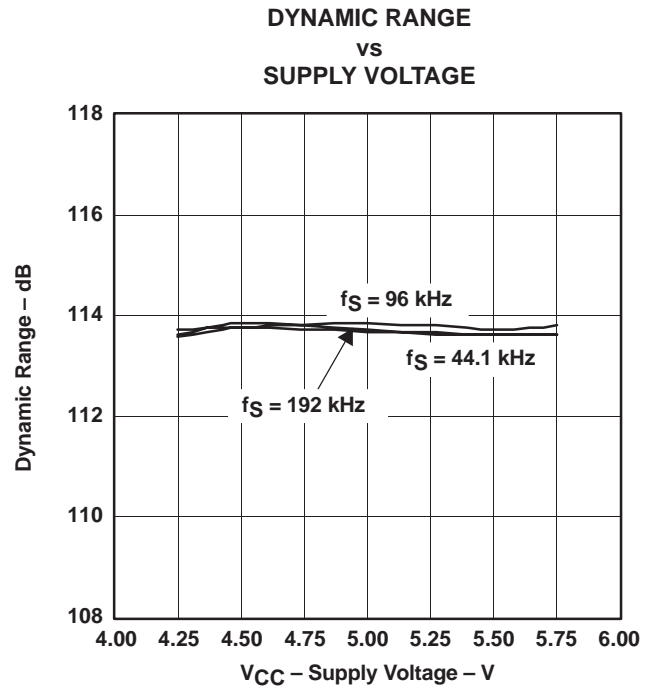

Figure 12

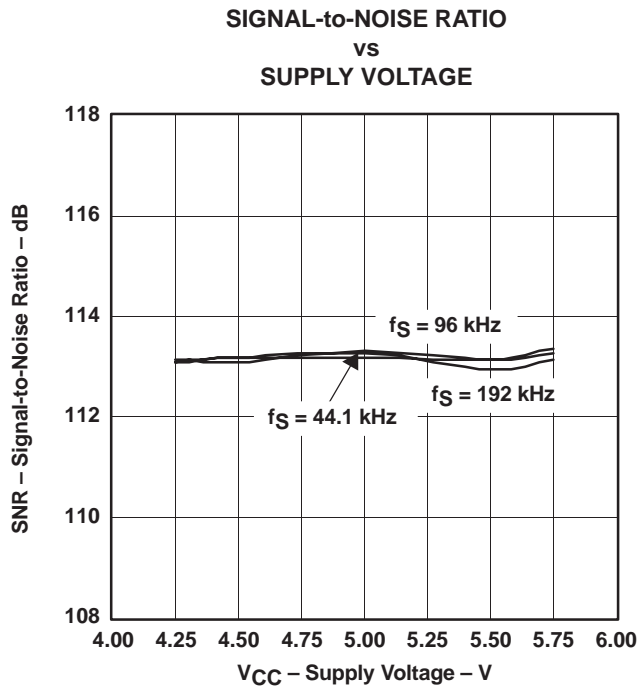

Figure 13

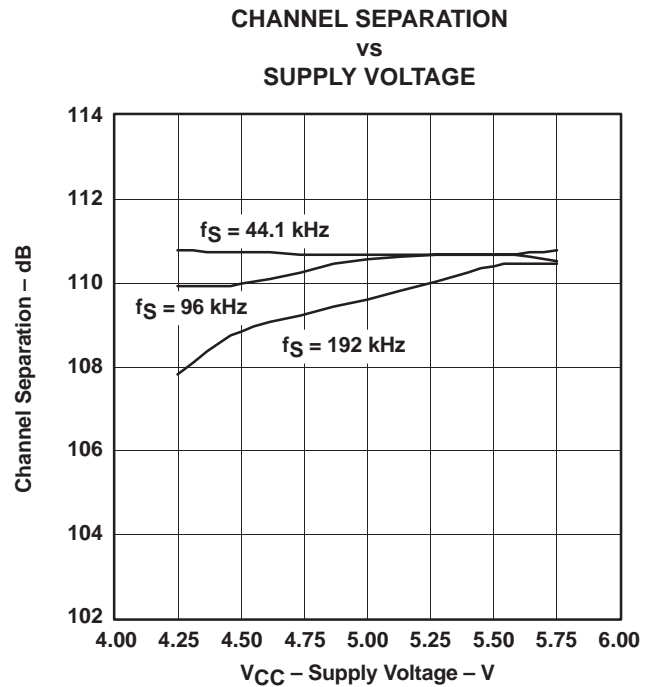

Figure 14

NOTE: PCM mode, T_A = 25°C, V_{DD} = 3.3 V

Temperature Characteristics

TOTAL HARMONIC DISTORTION + NOISE
vs
FREE-AIR TEMPERATURE

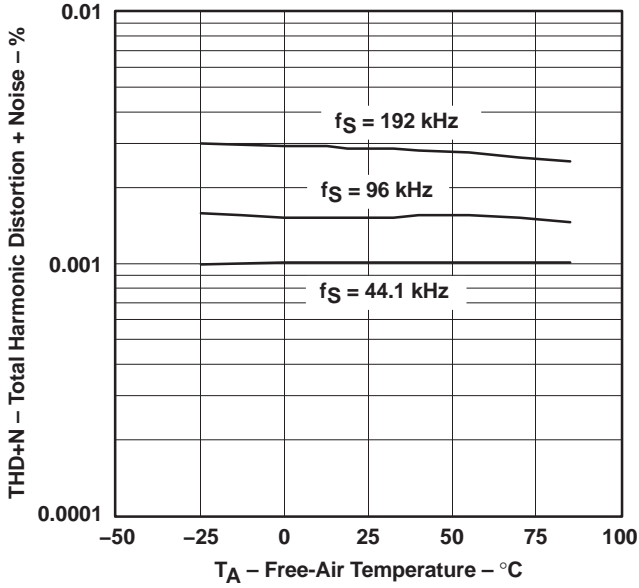

Figure 15

DYNAMIC RANGE
vs
FREE-AIR TEMPERATURE

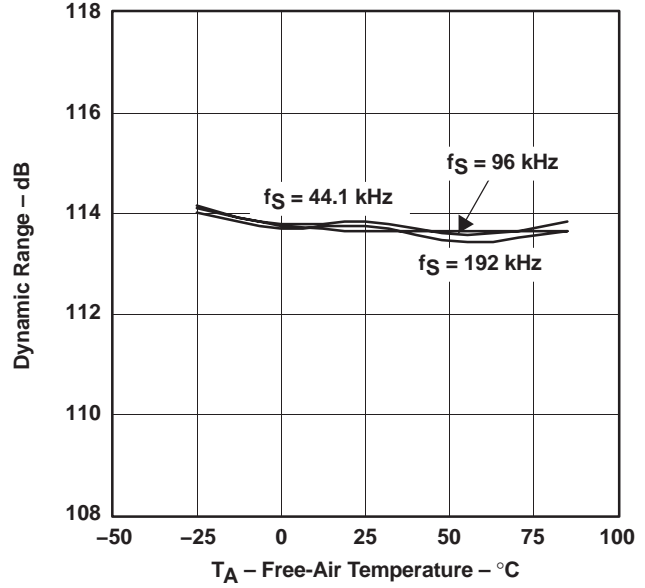

Figure 16

SIGNAL-to-NOISE RATIO
vs
FREE-AIR TEMPERATURE

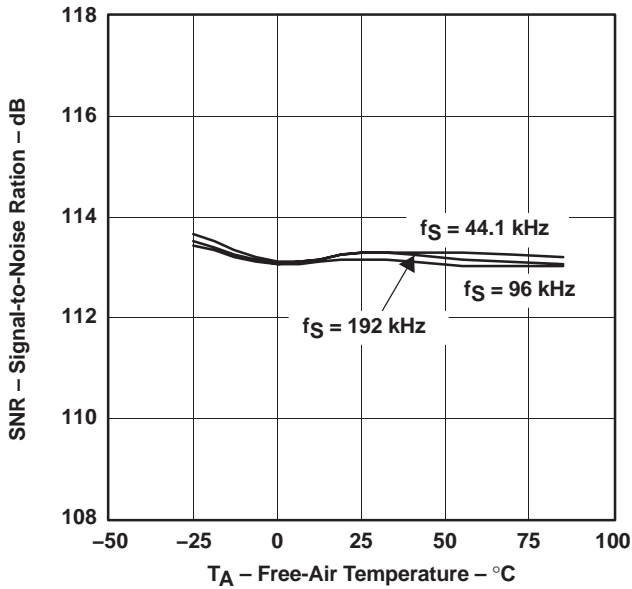

Figure 17

CHANNEL SEPARATION
vs
FREE-AIR TEMPERATURE

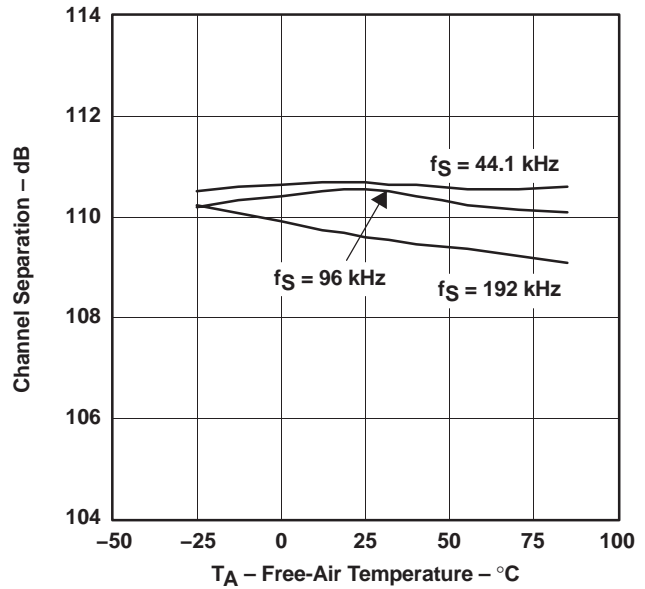

Figure 18

NOTE: PCM mode, V_{DD} = 3.3 V, V_{CC} = 5 V.

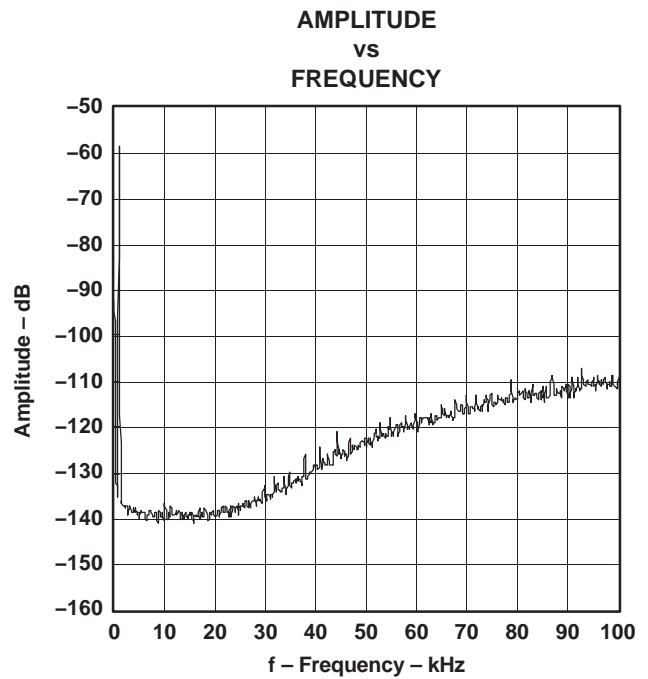
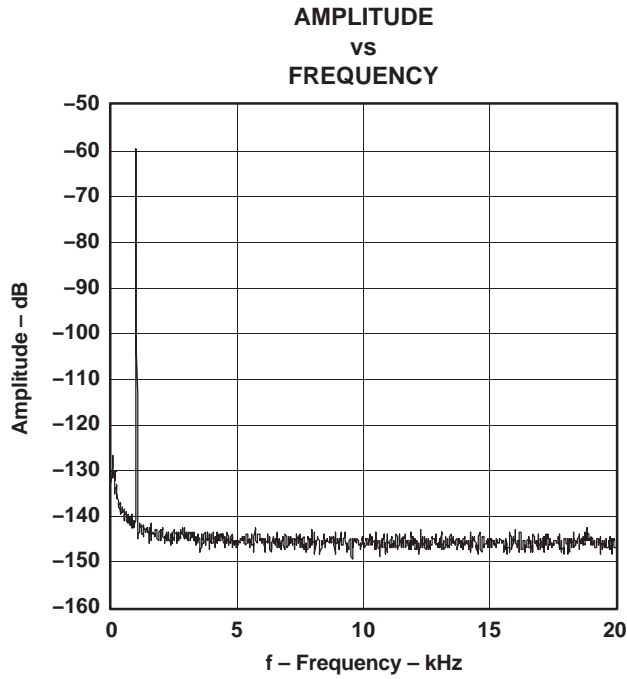

Figure 19. –60-dB Output Spectrum, BW = 20 kHz Figure 20. –60-dB Output Spectrum, BW = 100 kHz

NOTE: PCM mode, $f_S = 44.1$ kHz, 32768 points, 8 average, $T_A = 25^\circ\text{C}$, $V_{DD} = 3.3$ V, $V_{CC} = 5$ V

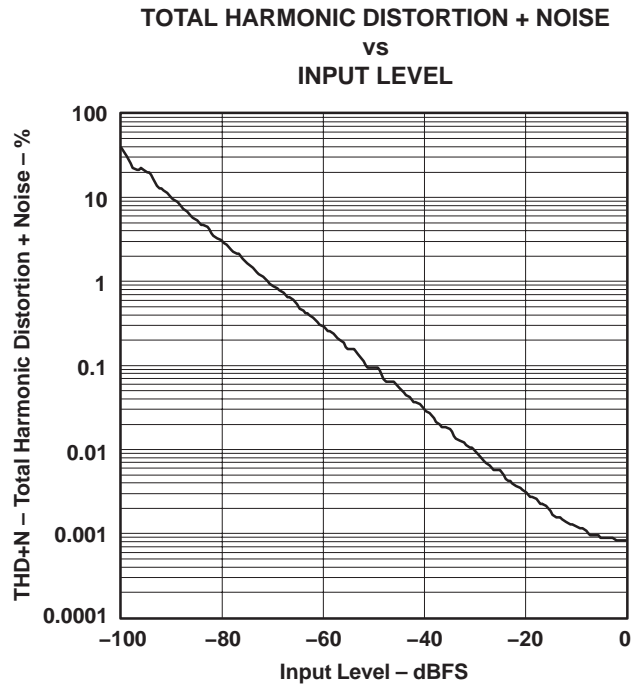

Figure 21. THD+N vs Input Level, PCM Mode

NOTE: PCM mode, $f_S = 44.1$ kHz, $T_A = 25^\circ\text{C}$, $V_{DD} = 3.3$ V, $V_{CC} = 5$ V

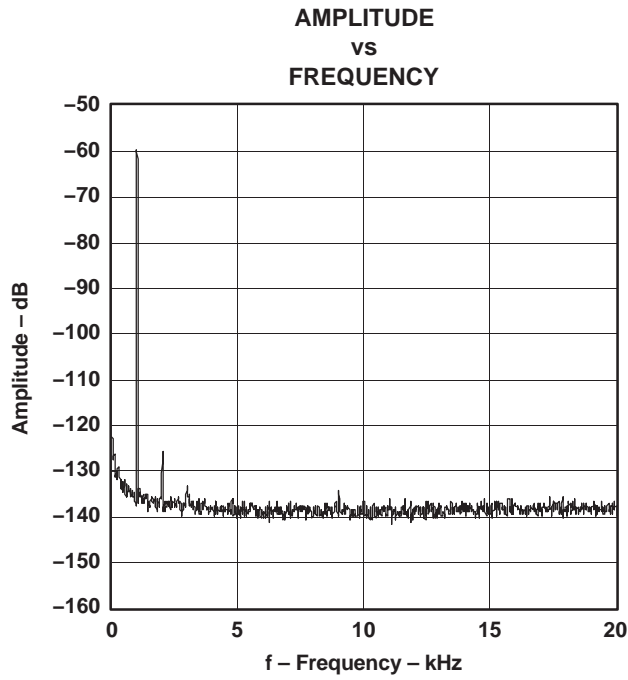

Figure 22. –60-dB Output Spectrum, DSD Mode

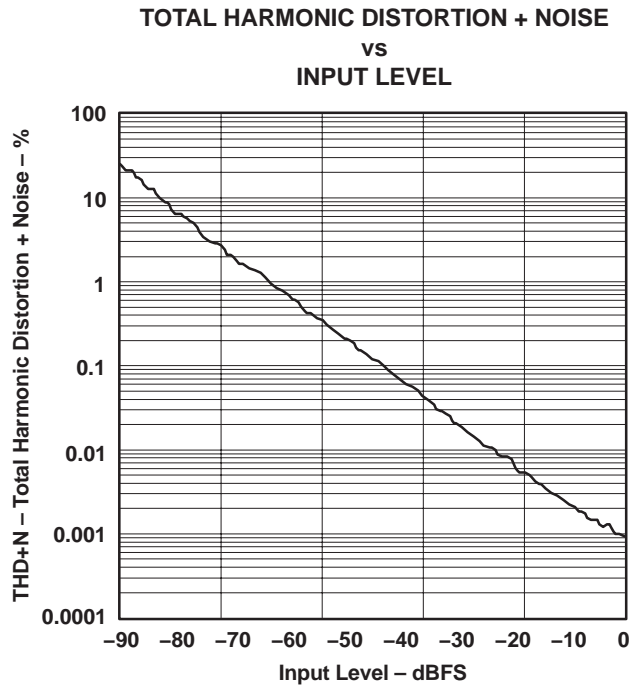

Figure 23. THD+N vs Input Level, DSD Mode

NOTE: DSD mode (FIR-2), $T_A = 25^\circ\text{C}$, $V_{DD} = 3.3\text{ V}$, $V_{CC} = 5\text{ V}$.

SYSTEM CLOCK AND RESET FUNCTIONS

System Clock Input

The DSD1791 requires a system clock for operating the digital interpolation filters and advanced segment DAC modulators. The system clock is applied at the SCK input (pin 5). The DSD1791 has a system clock detection circuit that automatically senses which frequency the system clock is operating. Table 1 shows examples of system clock frequencies for common audio sampling rates. If the oversampling rate of the delta-sigma modulator is selected as 128 f_s , the system clock frequency is required over 256 f_s .

Figure 24 shows the timing requirements for the system clock input. For optimal performance, it is important to use a clock source with low phase jitter and noise. One of the Texas Instruments PLL1700 family of multiclock generators is an excellent choice for providing the DSD1791 system clock.

Table 1. System Clock Rates for Common Audio Sampling Frequencies

SAMPLING FREQUENCY	SYSTEM CLOCK FREQUENCY (f_{SCK}) (MHz)					
	128 f_s	192 f_s	256 f_s	384 f_s	512 f_s	768 f_s
32 kHz	4.096	6.144	8.192	12.288	16.384	24.576
44.1 kHz	5.6488	8.4672	11.2896	16.9344	22.5792	33.8688
48 kHz	6.144	9.216	12.288	18.432	24.576	36.864
96 kHz	12.288	18.432	24.576	36.864	49.152	73.728
192 kHz	24.576	36.864	49.152	73.728	(1)	(1)

(1) This system clock rate is not supported for the given sampling frequency.

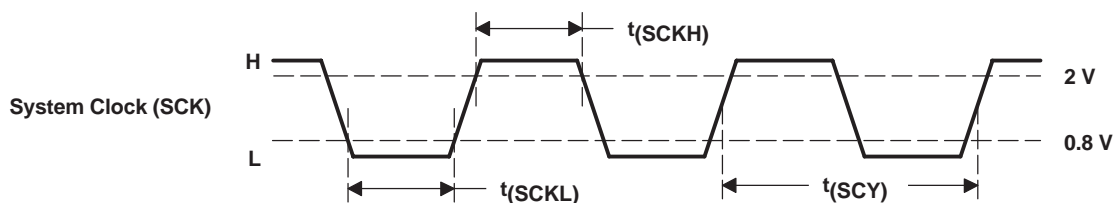

PARAMETERS		MIN	MAX	UNITS
$t(SCY)$	System clock pulse cycle time	13		ns
$t(SCKH)$	System clock pulse duration, HIGH	5		ns
$t(SCKL)$	System clock pulse duration, LOW	5		ns

Figure 24. System Clock Input Timing

Power-On and External Reset Functions

The DSD1791 includes a power-on reset function. Figure 25 shows the operation of this function. With $V_{DD} > 2$ V, the power-on reset function is enabled. The initialization sequence requires 1024 system clocks from the time $V_{DD} > 2$ V. After the initialization period, the DSD1791 is set to its default reset state, as described in the *MODE CONTROL REGISTERS* section of this data sheet.

The DSD1791 also includes an external reset capability using the \overline{RST} input (pin 6). This allows an external controller or master reset circuit to force the DSD1791 to initialize to its default reset state.

Figure 26 shows the external reset operation and timing. The \overline{RST} pin is set to logic 0 for a minimum of 20 ns. The \overline{RST} pin is then set to a logic 1 state, thus starting the initialization sequence, which requires 1024 system clock periods. The external reset is especially useful in applications where there is a delay between the DSD1791 power up and system clock activation.

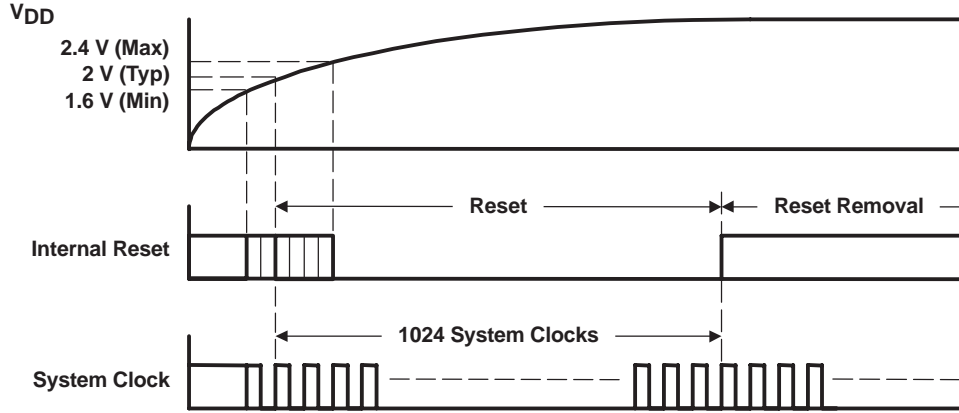
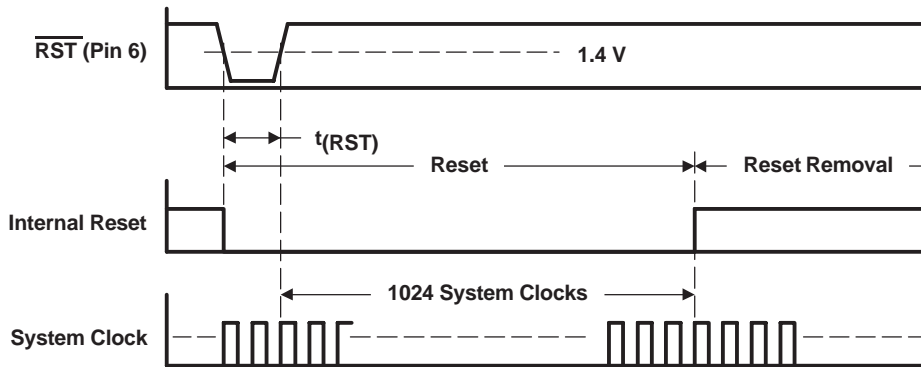

Figure 25. Power-On Reset Timing



PARAMETERS		MIN	MAX	UNITS
$t_{(RST)}$	Reset pulse duration, LOW	20		ns

Figure 26. External Reset Timing

AUDIO DATA INTERFACE

Audio Serial Interface

The audio interface port is a 3-wire serial port. It includes PLRCK (pin 1), PBCK (pin 2), and PDATA (pin 3). PBCK is the serial audio bit clock, and it is used to clock the serial data present on PDATA into the serial shift register of the audio interface. Serial data is clocked into the DSD1791 on the rising edge of PBCK. PLRCK is the serial audio left/right word clock.

The DSD1791 requires the synchronization of PLRCK and the system clock, but does not need a specific phase relationship between PLRCK and the system clock.

If the relationship between PLRCK and system clock changes more than ± 6 PBCK, internal operation is initialized within $1/f_S$ and analog outputs are forced to the bipolar zero level until resynchronization between PLRCK and the system clock is completed.

PCM Audio Data Formats and Timing

The DSD1791 supports industry-standard audio data formats, including standard right-justified, I^2S , and left-justified. The data formats are shown in Figure 28. Data formats are selected using the format bits, FMT[2:0], in control register 18. The default data format is 24-bit I^2S . All formats require binary 2s complement, MSB-first audio data. Figure 27 shows a detailed timing diagram for the serial audio interface.

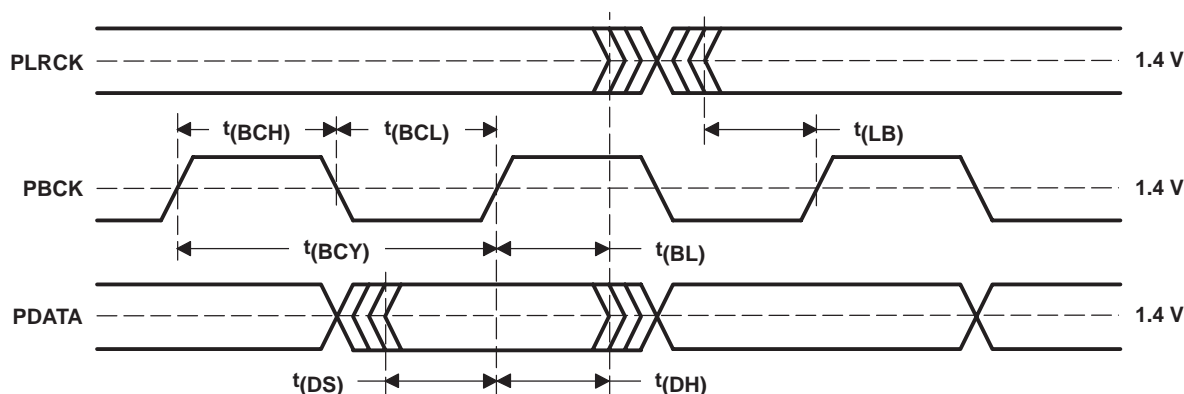

PARAMETERS		MIN	MAX	UNITS
$t(BCY)$	PBCK pulse cycle time	70		ns
$t(BCL)$	PBCK pulse duration, LOW	30		ns
$t(BCH)$	PBCK pulse duration, HIGH	30		ns
$t(BL)$	PBCK rising edge to PLRCK edge	10		ns
$t(LB)$	PLRCK edge to PBCK rising edge	10		ns
$t(DS)$	PDATA setup time	10		ns
$t(DH)$	PDATA hold time	10		ns
—	PLRCK clock data	50% \pm 2 bit clocks		

Figure 27. Timing of Audio Interface

(1) Standard Data Format (Right Justified) ; L-Channel = HIGH, R-Channel = LOW

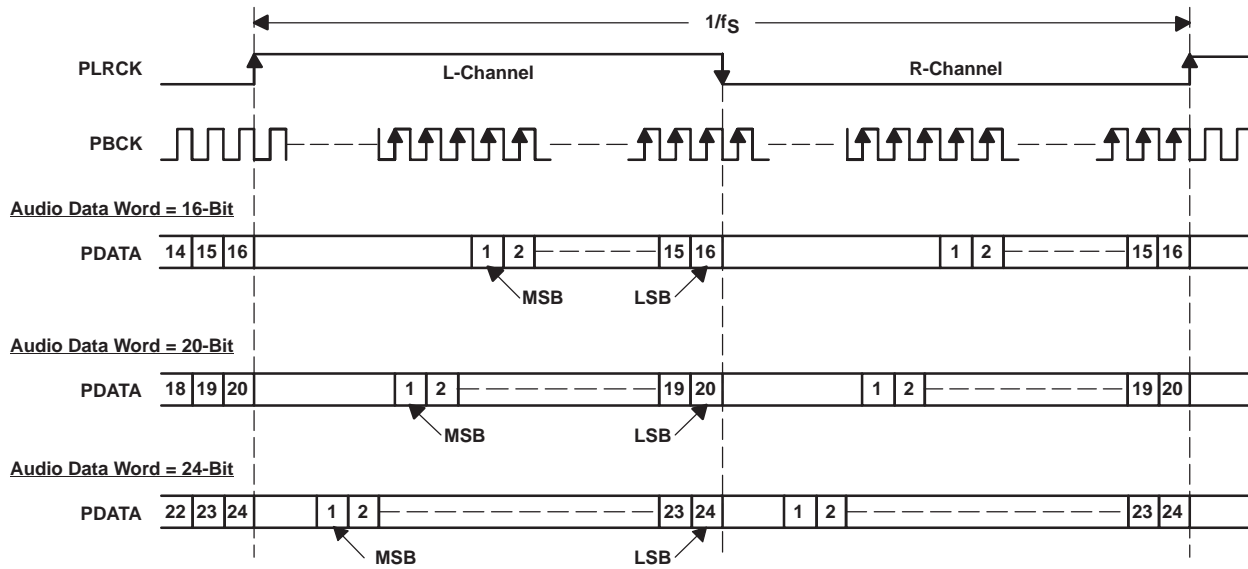

(2) Left Justified Data Format; L-Channel = HIGH, R-Channel = LOW

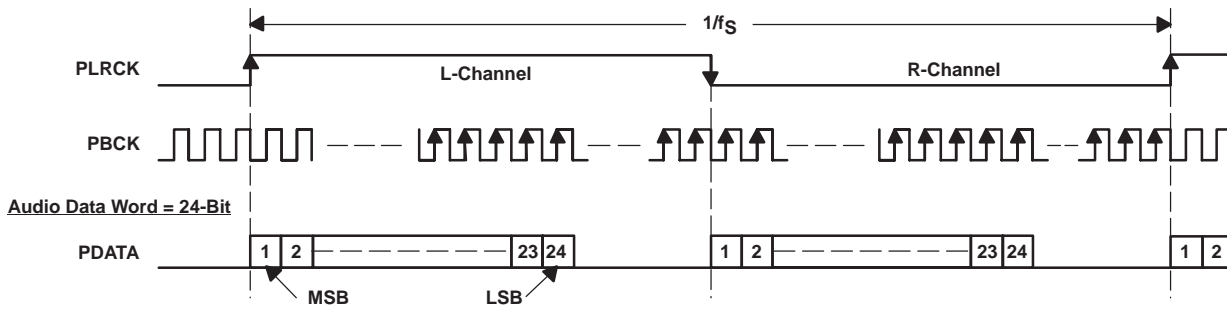

(3) I²S Data Format; L-Channel = LOW, R-Channel = HIGH

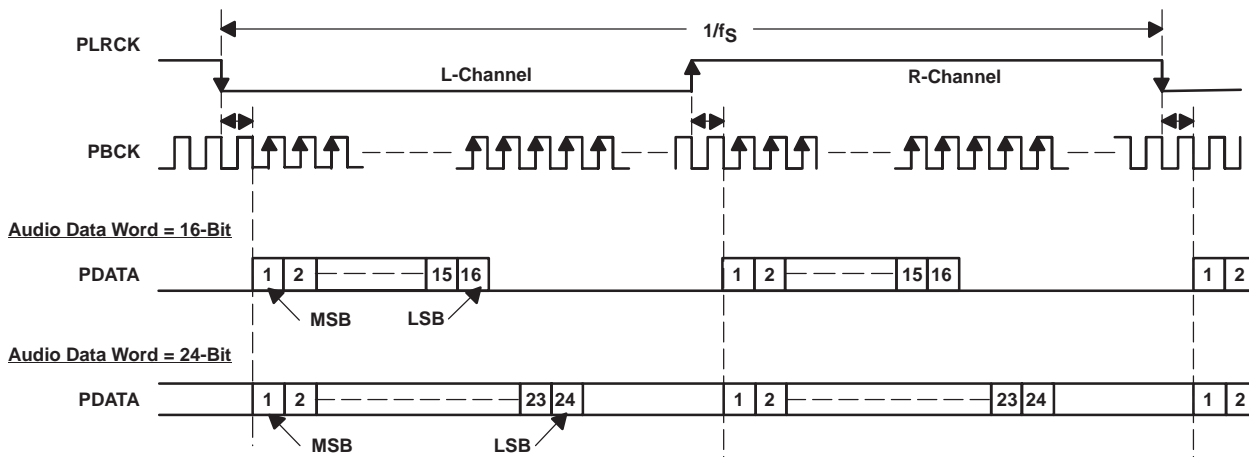

Figure 28. Audio Data Input Formats

External Digital Filter Interface and Timing

The DSD1791 supports an external digital filter interface with a 3- or 4-wire synchronous serial port, which allows the use of an external digital filter. External filters include the Texas Instruments DF1704 and DF1706, the Pacific Microsonics PMD200, or a programmable digital signal processor.

In the external DF mode, PLRCK (pin 1), PBCK (pin 2), and PDATA (pin 3) are defined as WDCK, the word clock; BCK, the bit clock; and DATA, the monaural data, respectively. The external digital filter interface is selected by using the DFTH bit of control register 20, which functions to bypass the internal digital filter of the DSD1791.

When the DFMS bit of control register 19 is set, the DSD1791 can process stereo data. In this case, DSDL (pin 25) and DSDR (pin 24) are defined as L-channel data and R-channel data input, respectively.

Detailed information for the external digital filter interface mode is provided in the *APPLICATION FOR EXTERNAL DIGITAL FILTER INTERFACE* section of this data sheet.

Direct Stream Digital (DSD) Format Interface and Timing

The DSD1791 supports the DSD format interface operation, which includes out-of-band noise filtering using an internal analog FIR filter. The DSD format interface consists of a 3-wire synchronous serial port, which includes DBCK (pin 4), DSDL (pin 25), and DSDR (pin 24). DBCK is the serial bit clock, DSDL and DSDR are the L-channel and R-channel DSD data inputs, respectively. They are clocked onto the DSD1791 on the rising edge of DBCK. PLRCK (pin 1) and PBCK (pin 2) should be connected to GND in the DSD mode. The DSD format (DSD mode) interface is activated by setting the DSD bit of control register 20.

Detailed information for the DSD mode is provided in the *APPLICATION FOR DSD-FORMAT (DSD MODE) INTERFACE* section of this data sheet.

TDMCA Interface

The DSD1791 supports the time-division-multiplexed command and audio (TDMCA) data format to enable control of and communication with a number of external devices over a single serial interface.

Detailed information for the TDMCA format is provided in the *TDMCA INTERFACE FORMAT* section of this data sheet.

FUNCTION DESCRIPTIONS

Zero Detect

The DSD1791 has a zero-detect function. When the DSD1791 detects the zero conditions as shown in Table 2, the DSD1791 sets ZEROL (pin 23) and ZEROR (pin 22) to HIGH.

Table 2. Zero Conditions

MODE		DETECTING CONDITION AND TIME
PCM		DATA is continuously LOW for 1024 LRCKs.
External DF mode		DATA is continuously LOW for 1024 WDCKs.
DSD	DZ0	There are an equal number of 1s and 0s in every 8 bits of DSD input data for 23 ms.
	DZ1	The input data is 1001 0110 continuously for 23 ms.

Serial Control Interface (SPI)

The serial control interface is a 3-wire synchronous serial port which operates asynchronously to the serial audio interface and the system clock (SCK). The serial control interface is used to program and read the on-chip mode registers. The control interface includes MDI (pin 26), MC (pin 27), and \overline{MS} (pin 28). MDI is the serial data input, used to program the mode registers; MC is the bit clock, used to shift data in and out of the control port, and \overline{MS} is the mode control enable, used to enable the internal-mode register access.

The serial interface can also read the mode registers to set the MDOE of control register 19 to 1. In that case, ZEROL (pin 23) is defined as the serial data output pin, and ZEROR (pin 22) is the logical AND of the L-channel and R-channel zero conditions.

Register Read/Write Operation

All read/write operations for the serial control port use 16-bit data words. Figure 29 shows the control data word format. The most significant bit is the read/write (R/\overline{W}) bit. For write operations, the R/\overline{W} bit must be set to 0. For read operations, the R/\overline{W} bit must be set to 1. There are seven bits, labeled $IDX[6:0]$, that hold the register index (or address) for the read and write operations. The least significant eight bits, $D[7:0]$, contain the data to be written to, or the data that was read from, the register specified by $IDX[6:0]$.

Figure 30 shows the functional timing diagram for writing or reading the serial control port. \overline{MS} is held at a logic 1 state until a register needs to be written or read. To start the register write or read cycle, \overline{MS} is set to logic 0. Sixteen clocks are then provided on MC, corresponding to the 16 bits of the control data word on MDI and readback data on ZEROL. After the eighth clock cycle has completed, the data from the indexed-mode control register appears on ZEROL during the read operation. After the sixteenth clock cycle has completed, the data is latched into the indexed-mode control register during the write operation. To write or read subsequent data, \overline{MS} must be set to 1 once.

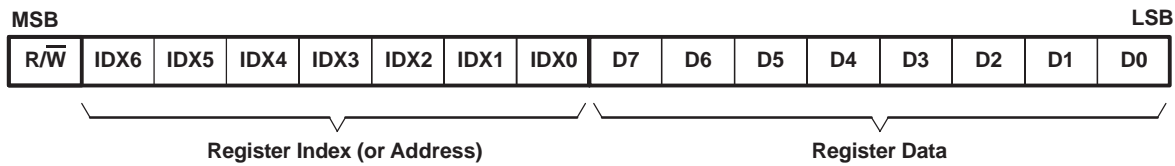
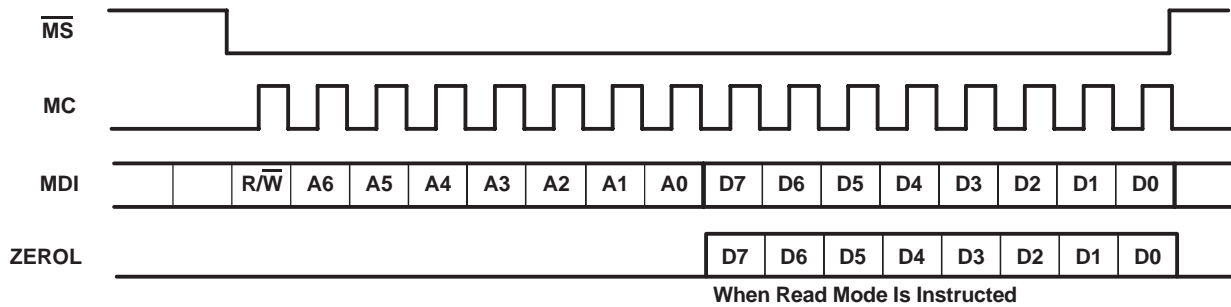
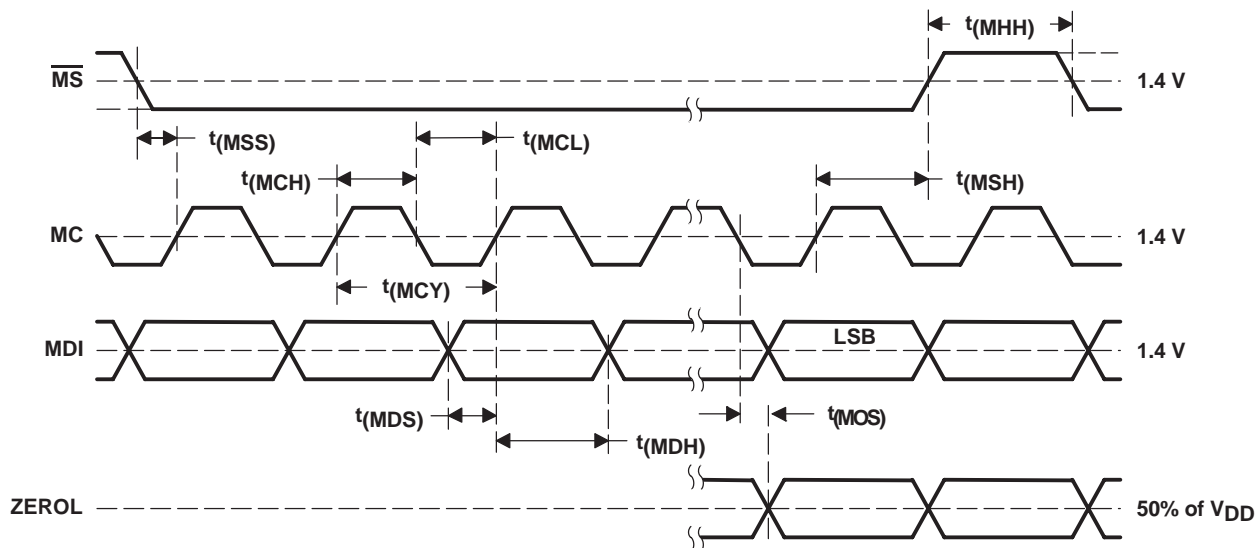

Figure 29. Control Data Word Format for MDI



NOTE: B15 is used for selection of write or read. Setting $R/\overline{W} = 0$ indicates a write, while $R/\overline{W} = 1$ indicates a read. Bits 14–8 are used for register address. Bits 7–0 are used for register data.

Figure 30. Serial Control Format



PARAMETER		MIN	MAX	UNITS
$t(MCY)$	MC pulse cycle time	100		ns
$t(MCL)$	MC low-level time	40		ns
$t(MCH)$	MC high-level time	40		ns
$t(MHH)$	\overline{MS} high-level time	80		ns
$t(MSS)$	\overline{MS} falling edge to MC rising edge	15		ns
$t(MSH)$	\overline{MS} hold time ⁽¹⁾	15		ns
$t(MDH)$	MDI hold time	15		ns
$t(MDS)$	MDI setup time	15		ns
$t(MOS)$	MC falling edge to ZEROL stable		30	ns

⁽¹⁾ MC rising edge for LSB to \overline{MS} rising edge

Figure 31. Control Interface Timing

MODE CONTROL REGISTERS

User-Programmable Mode Controls

The DSD1791 includes a number of user-programmable functions which are accessed via mode control registers. The registers are programmed using the serial control interface, which was previously discussed in this data sheet. Table 3 lists the available mode-control functions, along with their default reset conditions and associated register index.

Table 3. User-Programmable Function Controls

FUNCTION	DEFAULT	REGISTER	BIT	PCM	DSD	DF BYPASS
Digital attenuation control 0 dB to –120 dB and mute, 0.5 dB/step	0 dB	Register 16 Register 17	ATL[7:0] (for L-ch) ATR[7:0] (for R-ch)	yes		
Attenuation load control Disabled, enabled	Attenuation disabled	Register 18	ATLD	yes		
Input audio data format selection 16-, 20-, 24-bit standard (right-justified) format 24-bit MSB-first left-justified format 16-/24-bit I ² S format	24-bit I ² S format	Register 18	FMT[2:0]	yes		yes
Sampling rate selection for de-emphasis Disabled, 44.1 kHz, 48 kHz, 32 kHz	De-emphasis disabled	Register 18	DMF[1:0]	yes	yes ⁽¹⁾	
De-emphasis control Disabled, enabled	De-emphasis disabled	Register 18	DME	yes		
Soft mute control Mute disabled, enabled	Mute disabled	Register 18	MUTE	yes		
Output phase reversal Normal, reverse	Normal	Register 19	REV	yes	yes	yes
Attenuation speed selection $\times 1 f_s$, $\times (1/2)f_s$, $\times (1/4)f_s$, $\times (1/8)f_s$	$\times 1 f_s$	Register 19	ATS[1:0]	yes		
DAC operation control Enabled, disabled	DAC operation enabled	Register 19	OPE	yes	yes	yes
MDO output enable Enabled, disabled	Disabled	Register 19	MDOE	yes	yes	yes
Stereo DF bypass mode select Monaural, stereo	Monaural	Register 19	DFMS			yes
Digital filter rolloff selection Sharp rolloff, slow rolloff	Sharp rolloff	Register 19	FLT	yes		
Infinite zero mute control Disabled, enabled	Disabled	Register 19	INZD	yes		yes
System reset control Reset operation, normal operation	Normal operation	Register 20	SRST	yes	yes	yes
DSD interface mode control DSD enabled, disabled	Disabled	Register 20	DSD	yes	yes	
Digital-filter bypass control DF enabled, DF bypassed	DF enabled	Register 20	DFTH	yes		yes
Monaural mode selection Stereo, monaural	Stereo	Register 20	MONO	yes	yes	yes
Channel selection for monaural mode data L-channel, R-channel	L-channel	Register 20	CHSL	yes	yes	yes
Delta-sigma oversampling rate selection $\times 64 f_s$, $\times 128 f_s$, $\times 32 f_s$	$\times 64 f_s$	Register 20	OS[1:0]	yes	yes ⁽²⁾	yes
PCM zero output enable Enabled, disabled	Enabled	Register 21	PCMZ	yes		yes
DSD zero output enable Enabled, disabled	Disabled	Register 21	DZ[1:0]		yes	
Function Available Only for Read						
Zero detection flag Not zero, zero detected	Not zero = 0 Zero detected = 1	Register 22	ZFGL (for L-ch) ZFGR (for R-ch)	yes	yes	yes
Device ID (at TDMCA)	–	Register 23	ID[4:0]	yes	yes	

(1) When in DSD mode, DMF[1:0] is defined as DSD filter (analog FIR) performance selection.

(2) When in DSD mode, OS[1:0] is defined as DSD filter (analog FIR) operation rate selection.

Register Map

The mode control register map is shown in Table 4. Registers 16–21 include an R/\overline{W} bit, which determines whether a register read ($R/\overline{W} = 1$) or write ($R/\overline{W} = 0$) operation is performed. Registers 22 and 23 are read-only.

Table 4. Mode Control Register Map

	B15	B14	B13	B12	B11	B10	B9	B8	B7	B6	B5	B4	B3	B2	B1	B0
Register 16	R/\overline{W}	0	0	1	0	0	0	0	ATL7	ATL6	ATL5	ATL4	ATL3	ATL2	ATL1	ATL0
Register 17	R/\overline{W}	0	0	1	0	0	0	1	ATR7	ATR6	ATR5	ATR4	ATR3	ATR2	ATR1	ATR0
Register 18	R/\overline{W}	0	0	1	0	0	1	0	ATLD	FMT2	FMT1	FMT0	DMF1	DMF0	DME	MUTE
Register 19	R/\overline{W}	0	0	1	0	0	1	1	REV	ATS1	ATS0	OPE	MDOE	DFMS	FLT	INZD
Register 20	R/\overline{W}	0	0	1	0	1	0	0	RSV	SRST	DSD	DFTH	MONO	CHSL	OS1	OS0
Register 21	R/\overline{W}	0	0	1	0	1	0	1	RSV	RSV	RSV	RSV	RSV	DZ1	DZ0	PCMZ
Register 22	R	0	0	1	0	1	1	0	RSV	RSV	RSV	RSV	RSV	RSV	ZFGR	ZFGL
Register 23	R	0	0	1	0	1	1	1	RSV	RSV	RSV	ID4	ID3	ID2	ID1	ID0

Register Definitions

	B15	B14	B13	B12	B11	B10	B9	B8	B7	B6	B5	B4	B3	B2	B1	B0
Register 16	R/\overline{W}	0	0	1	0	0	0	0	ATL7	ATL6	ATL5	ATL4	ATL3	ATL2	ATL1	ATL0
Register 17	R/\overline{W}	0	0	1	0	0	0	1	ATR7	ATR6	ATR5	ATR4	ATR3	ATR2	ATR1	ATR0

R/\overline{W} : Read/Write Mode Select

When $R/\overline{W} = 0$, a write operation is performed.

When $R/\overline{W} = 1$, a read operation is performed.

Default value: 0

ATx[7:0]: Digital Attenuation Level Setting

These bits are available for read and write.

Default value: 1111 1111b

Each DAC output has a digital attenuator associated with it. The attenuator can be set from 0 dB to –120 dB, in 0.5-dB steps. Alternatively, the attenuator can be set to infinite attenuation (or mute).

The attenuation data for each channel can be set individually. However, the data load control (the ATLD bit of control register 18) is common to both attenuators. ATLD must be set to 1 in order to change an attenuator setting. The attenuation level can be set using the following formula:

$$\text{Attenuation level (dB)} = 0.5 \text{ dB} \cdot (\text{ATx}[7:0]_{\text{DEC}} - 255)$$

where $\text{ATx}[7:0]_{\text{DEC}} = 0$ through 255

For $\text{ATx}[7:0]_{\text{DEC}} = 0$ through 14, the attenuator is set to infinite attenuation. The following table shows attenuation levels for various settings:

ATx[7:0]	Decimal Value	Attenuation Level Setting
1111 1111b	255	0 dB, no attenuation (default)
1111 1110b	254	–0.5 dB
1111 1101b	253	–1.0 dB
⋮	⋮	⋮
0001 0000b	16	–119.5 dB
0000 1111b	15	–120.0 dB
0000 1110b	14	Mute
⋮	⋮	⋮
0000 0000b	0	Mute

	B15	B14	B13	B12	B11	B10	B9	B8	B7	B6	B5	B4	B3	B2	B1	B0
Register 18	R/W	0	0	1	0	0	1	0	ATLD	FMT2	FMT1	FMT0	DMF1	DMF0	DME	MUTE

R/W: Read/Write Mode Select

When $R/\overline{W} = 0$, a write operation is performed.

When $R/\overline{W} = 1$, a read operation is performed.

Default value: 0

ATLD: Attenuation Load Control

This bit is available for read and write.

Default value: 0

ATLD = 0	Attenuation control disabled (default)
ATLD = 1	Attenuation control enabled

The ATLD bit enables loading of the attenuation data contained in registers 16 and 17. When ATLD = 0, the attenuation settings remain at the previously programmed levels, ignoring new data loaded from registers 16 and 17. When ATLD = 1, attenuation data written to registers 16 and 17 is loaded normally.

FMT[2:0]: Audio Interface Data Format

These bits are available for read and write.

Default value: 101

FMT[2:0]	Audio Data Format Selection
000	16-bit standard format, right-justified data
001	20-bit standard format, right-justified data
010	24-bit standard format, right-justified data
011	24-bit MSB-first, left-justified format data
100	16-bit I ² S format data
101	24-bit I ² S format data (default)
110	Reserved
111	Reserved

The FMT[2:0] bits select the data format for the serial audio interface.

For the external digital filter interface mode (DFTH mode), this register is operated as shown in the *APPLICATION FOR EXTERNAL DIGITAL FILTER INTERFACE* section of this data sheet.

DMF[1:0]: Sampling Frequency Selection for the De-Emphasis Function

These bits are available for read and write.

Default value: 00

DMF[1:0]	De-Emphasis Sampling Frequency Selection
00	Disabled (default)
01	48 kHz
10	44.1 kHz
11	32 kHz

The DMF[1:0] bits select the sampling frequency used by the digital de-emphasis function when it is enabled by setting the DME bit. The de-emphasis curves are shown in the *TYPICAL PERFORMANCE CURVES* section of this data sheet.

For the DSD mode, analog FIR filter performance can be selected using this register. A register map and filter response plots are shown in the *APPLICATION FOR DSD FORMAT (DSD MODE) INTERFACE* section of this data sheet.

DME: Digital De-Emphasis Control

This bit is available for read and write.
 Default value: 0

DME = 0	De-emphasis disabled (default)
DME = 1	De-emphasis enabled

The DME bit enables or disables the de-emphasis function for both channels.

MUTE: Soft Mute Control

This bit is available for read and write.
 Default value: 0

MUTE = 0	MUTE disabled (default)
MUTE = 1	MUTE enabled

The MUTE bit enables or disables the soft mute function for both channels.

Soft mute is operated as a 256-step attenuator. The speed for each step to $-\infty$ dB (mute) is determined by the attenuation rate selected in the ATS register.

	B15	B14	B13	B12	B11	B10	B9	B8	B7	B6	B5	B4	B3	B2	B1	B0
Register 19	R/W	0	0	1	0	0	1	1	REV	ATS1	ATS0	OPE	MDOE	DFMS	FLT	INZD

R/W: Read/Write Mode Select

When R/\overline{W} = 0, a write operaton is performed.
 When R/\overline{W} = 1, a read operaton is performed.
 Default value: 0

REV: Output Phase Reversal

This bit is available for read and write.
 Default value: 0

REV = 0	Normal output (default)
REV = 1	Inverted output

The REV bit inverts the output phase for both channels.

ATS[1:0]: Attenuation Rate Select

These bits are available for read and write.
 Default value: 00

ATS[1:0]	Attenuation Rate Selection
00	Every PLRCK (default)
01	PLRCK/2
10	PLRCK/4
11	PLRCK/8

The ATS[1:0] bits select the rate at which the attenuator is decremented/incremented during level transitions.

OPE: DAC Operation Control

This bit is available for read and write.
 Default value: 0

OPE = 0	DAC operation enabled (default)
OPE = 1	DAC operation disabled

The OPE bit enables or disables the analog output for both channels. Disabling the analog outputs forces them to the bipolar zero level (BPZ) even if digital audio data is present on the input.

MDOE: MDO Output Control

This bit is available for read and write.
Default value: 0

MDOE = 0	MDO output disabled (default)
MDOE = 1	MDO output enabled

The MDOE bit enables or disables the serial mode data output. The serial mode data is output from ZEROL (pin 23).

DFMS: Stereo DF Bypass Mode Select

This bit is available for read and write.
Default value: 0

DFMS = 0	Monaural (default)
DFMS = 1	Stereo input enabled

The DFMS bit enables stereo operation in DF bypass mode. In DF bypass mode, when DFMS is set to 0, the pin for the input data is PDATA (pin 3) only; therefore, the DSD1791 operates as a monaural DAC. When DFMS is set to 1, the DSD1791 can operate as a stereo DAC with inputs of L-channel and R-channel data on DSDL (pin 25) and DSDR (pin 24), respectively.

FLT: Digital Filter Rolloff Control

This bit is available for read and write.
Default value: 0

FLT = 0	Sharp rolloff (default)
FLT = 1	Slow rolloff

The FLT bit selects the digital filter rolloff characteristic. The filter responses for these selections are shown in the *TYPICAL PERFORMANCE CURVES* section of this data sheet.

INZD: Infinite Zero Detect Mute Control

This bit is available for read and write.
Default value: 0

INZD = 0	Infinite zero detect mute disabled (default)
INZD = 1	Infinite zero detect mute enabled

The INZD bit enables or disables the zero detect mute function. Setting INZD to 1 forces muted analog outputs to hold a bipolar zero level when the DSD1791 detects a zero condition in both channels. The infinite zero detect mute function is not available in the DSD mode.

	B15	B14	B13	B12	B11	B10	B9	B8	B7	B6	B5	B4	B3	B2	B1	B0
Register 20	R/W	0	0	1	0	1	0	0	RSV	SRST	DSD	DFTH	MONO	CHSL	OS1	OS0

R/W: Read/Write Mode Select

When R/W = 0, a write operation is performed.
When R/W = 1, a read operation is performed.
Default value: 0

SRST: System Reset Control

This bit is available for write only.
Default value: 0

SRST = 0	Normal operation (default)
SRST = 1	System reset operation (generate one reset pulse)

The SRST bit resets the DSD1791 to the initial system condition.

DSD: DSD Interface Mode Control

This bit is available for read and write.
 Default value: 0

DSD = 0	DSD interface mode disabled (default)
DSD = 1	DSD interface mode enabled

The DSD bit enables or disables the DSD interface mode.

DFTH: Digital Filter Bypass (or Through Mode) Control

This bit is available for read and write.
 Default value: 0

DFTH = 0	Digital filter enabled (default)
DFTH = 1	Digital filter bypassed for the external digital filter

The DFTH bit enables or disables the external digital filter interface mode.

MONO: Monaural Mode Selection

This bit is available for read and write.
 Default value: 0

MONO = 0	Stereo mode (default)
MONO = 1	Monaural mode

The MONO function changes the operation mode from the normal stereo mode to the monaural mode. When the monaural mode is selected, both DACs operate in a balanced mode for one channel of audio input data. Channel selection is available for L-channel or R-channel data, determined by the CHSL bit as described immediately following.

CHSL: Channel Selection for Monaural Mode

This bit is available for read and write.
 Default value: 0

CHSL = 0	L-channel selected (default)
CHSL = 1	R-channel selected

This bit is available when MONO = 1.

The CHSL bit selects L-channel or R-channel data to be used in monaural mode.

OS[1:0]: Delta-Sigma Oversampling Rate Selection

These bits are available for read and write.
 Default value: 00

OS[1:0]	Operation Speed Select
00	64 times f_S (default)
01	32 times f_S
10	128 times f_S
11	Reserved

The OS bits change the oversampling rate of delta-sigma modulation. Use of this function enables the designer to stabilize the conditions at the post low-pass filter for different sampling rates. As an application example, programming to set 128 times in 44.1-kHz operation, 64 times in 96-kHz operation, and 32 times in 192-kHz operation allows the use of only a single type (cutoff frequency) of post low-pass filter. The 128 f_S oversampling rate is not available at sampling rates above 100 kHz. If the 128- f_S oversampling rate is selected, a system clock of more than 256 f_S is required.

In DSD mode, these bits select the speed of the bit clock for DSD data coming into the analog FIR filter.

	B15	B14	B13	B12	B11	B10	B9	B8	B7	B6	B5	B4	B3	B2	B1	B0
Register 21	R/W	0	0	1	0	1	0	1	RSV	RSV	RSV	RSV	RSV	DZ1	DZ0	PCMZ

R/W: Read/Write Mode Select

When $R/\overline{W} = 0$, a write operation is performed.

When $R/\overline{W} = 1$, a read operation is performed.

Default value: 0

DZ[1:0]: DSD Zero Output Enable

These bits are available for read and write.

Default value: 00

DZ[1:0]	Zero Output Enable
00	Disabled (default)
01	Even pattern detect
1x	96 _H pattern detect

The DZ bits enable or disable the output zero flags, and select the zero pattern in the DSD mode.

PCMZ: PCM Zero Output Enable

This bit is available for read and write.

Default value: 1

PCMZ = 0	PCM zero output disabled
PCMZ = 1	PCM zero output enabled (default)

The PCMZ bit enables or disables the output zero flags in the PCM mode and the external DF mode.

	B15	B14	B13	B12	B11	B10	B9	B8	B7	B6	B5	B4	B3	B2	B1	B0
Register 22	R	0	0	1	0	1	1	0	RSV	RSV	RSV	RSV	RSV	RSV	ZFGR	ZFGL

R: Read Mode Select

Value is always 1, specifying the readback mode.

ZFGx: Zero-Detection Flag

where x = L or R, corresponding to the DAC output channel. These bits are available only for readback.

Default value: 00

ZFGx = 0	Not zero
ZFGx = 1	Zero detected

These bits show zero conditions. Their status is the same as that of the zero flags at ZEROL (pin 23) and ZEROR (pin 22). See *Zero Detect* in the *FUNCTIONAL DESCRIPTIONS* section.

	B15	B14	B13	B12	B11	B10	B9	B8	B7	B6	B5	B4	B3	B2	B1	B0
Register 23	R	0	0	1	0	1	1	1	RSV	RSV	RSV	ID4	ID3	ID2	ID1	ID0

R: Read Mode Select

Value is always 1, specifying the readback mode.

ID[4:0]: Device ID

The ID[4:0] bits hold a device ID in the TDMCA mode.

TYPICAL CONNECTION DIAGRAM

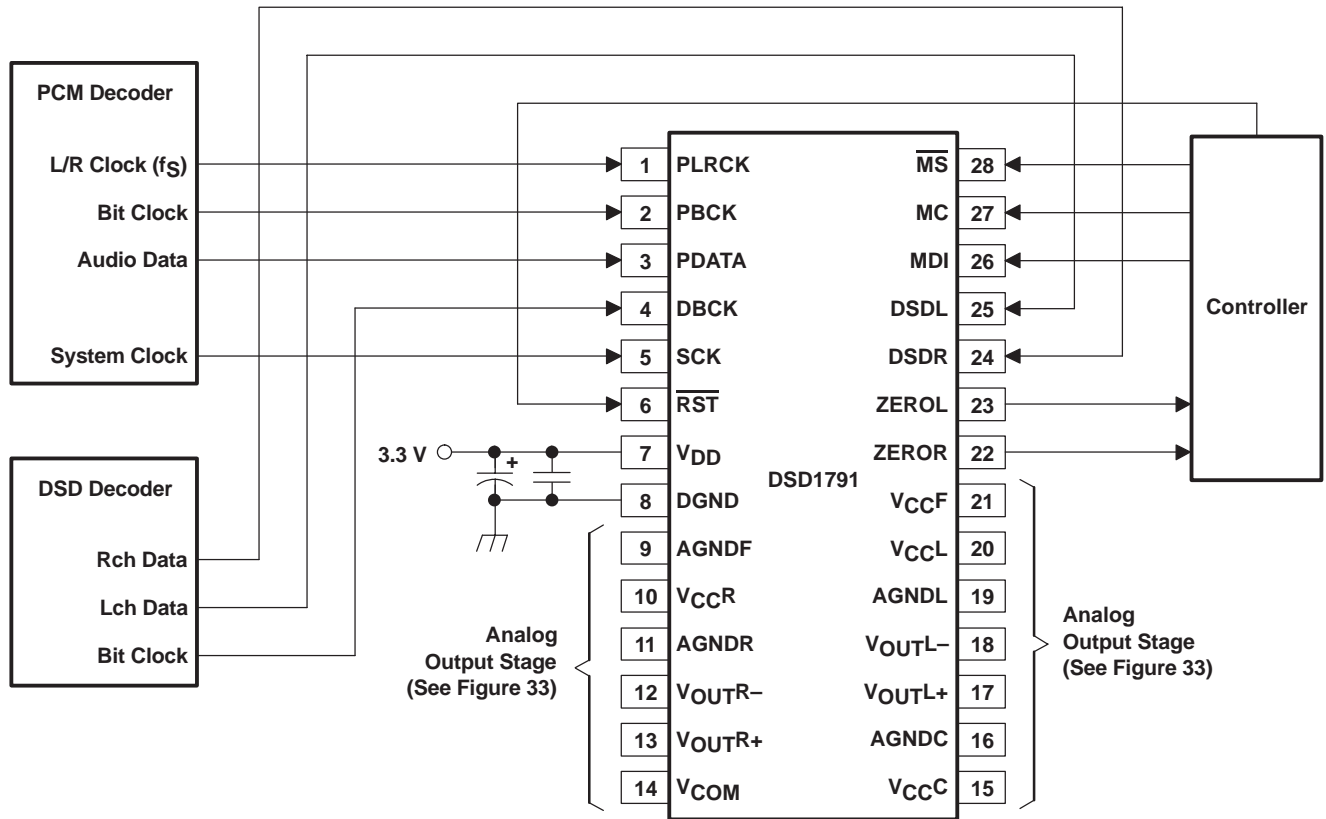
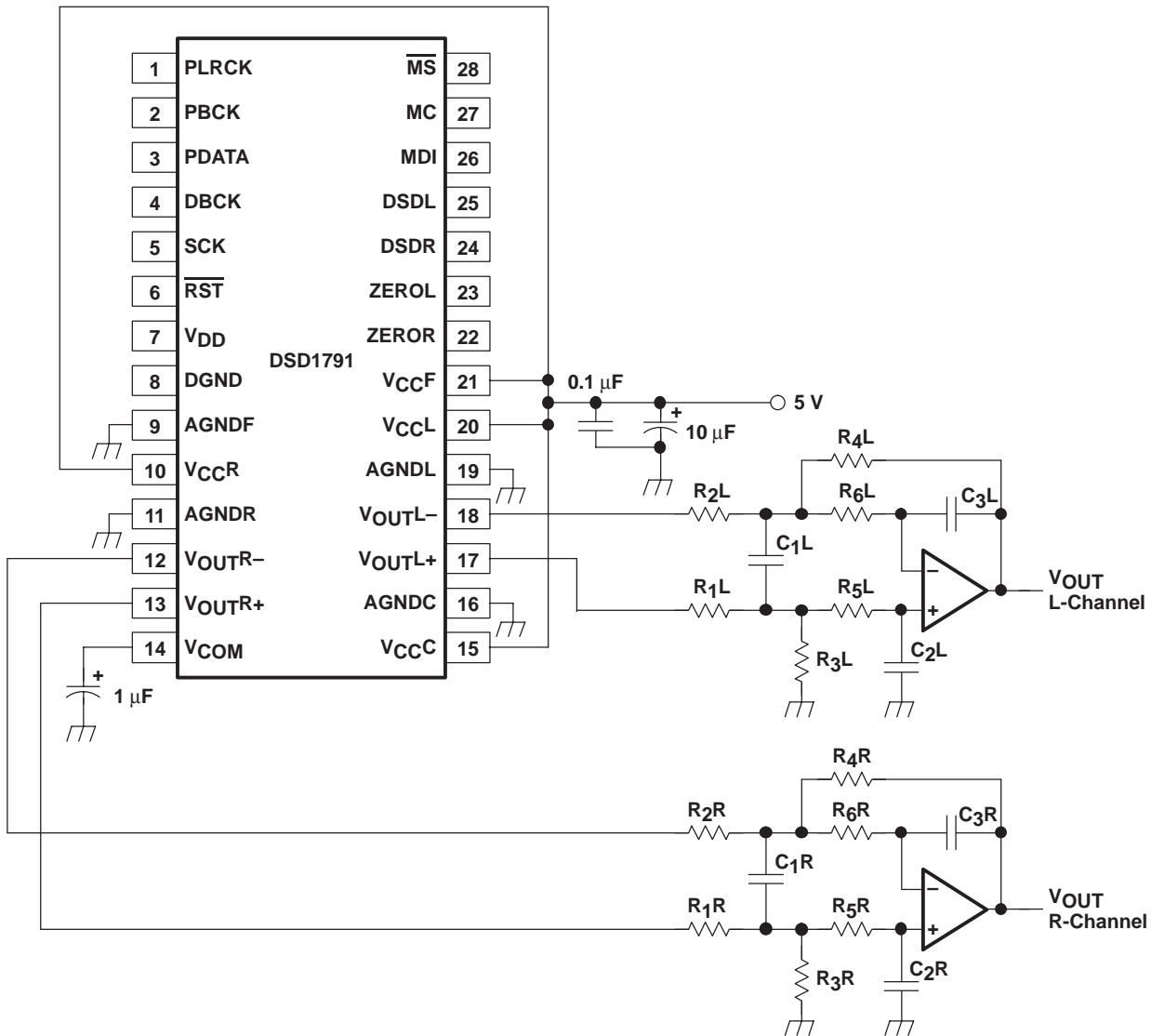

Figure 32. Typical Application Circuit

APPLICATION INFORMATION

ANALOG OUTPUTS



NOTE: Example R and C values for $f_C = 77$ kHz – R_1, R_2 : 1.8 k Ω , R_3, R_4 : 3.3 k Ω , R_5, R_6 : 680 Ω , C_1 : 1800 pF, C_2, C_3 : 560 pF.

Figure 33. Typical Application for Analog Output Stage

Analog Output Level and LPF

The signal level of the DAC differential-voltage output $\{(V_{OUTL+}) - (V_{OUTL-}), (V_{OUTR+}) - (V_{OUTR-})\}$ is 3.2 V_{p-p} at 0 dB (full scale). The voltage output of the LPF is given by following equation:

$$V_{OUT} = 3.2 \text{ V}_{p-p} \times (R_f / R_i)$$

Here, R_f is the feedback resistor in the LPF, and $R_3 = R_4$ in a typical application circuit. R_i is the input resistor in the LPF, and $R_1 = R_2$ in a typical application circuit.

Operational Amplifier for LPF

An OPA2134 or 5532 type operational amplifier is recommended for the LPF circuit to obtain the specified audio performance. Dynamic performance such as gain bandwidth, settling time, and slew rate of the operational amplifier largely determines the audio dynamic performance of the LPF section. The input noise specification of the operational amplifier should be considered to obtain a 113-dB S/N ratio.

Analog Gain of Balanced Amplifier

The DAC voltage outputs are followed by balanced amplifier stages, which sum the differential signals for each channel, creating a single-ended voltage output. In addition, the balanced amplifiers provide a third-order low-pass filter function, which band limits the audio output signal. The cutoff frequency and gain are determined by external R and C component values. In this case, the cutoff frequency is 77 kHz with a gain of 1.83. The output voltage for each channel is 5.9 V_{p-p}, or 2.1 V_{rms}.

Application for Monaural-Mode Operation

A single-channel signal from the stereo audio data input is output from both V_{OUTL} and V_{OUTR} as a differential output. The channel to be output is selected by setting the CHSL bit in register 20. The advantage of monaural operation is to provide over 115 dB of dynamic range for high-end audio applications.

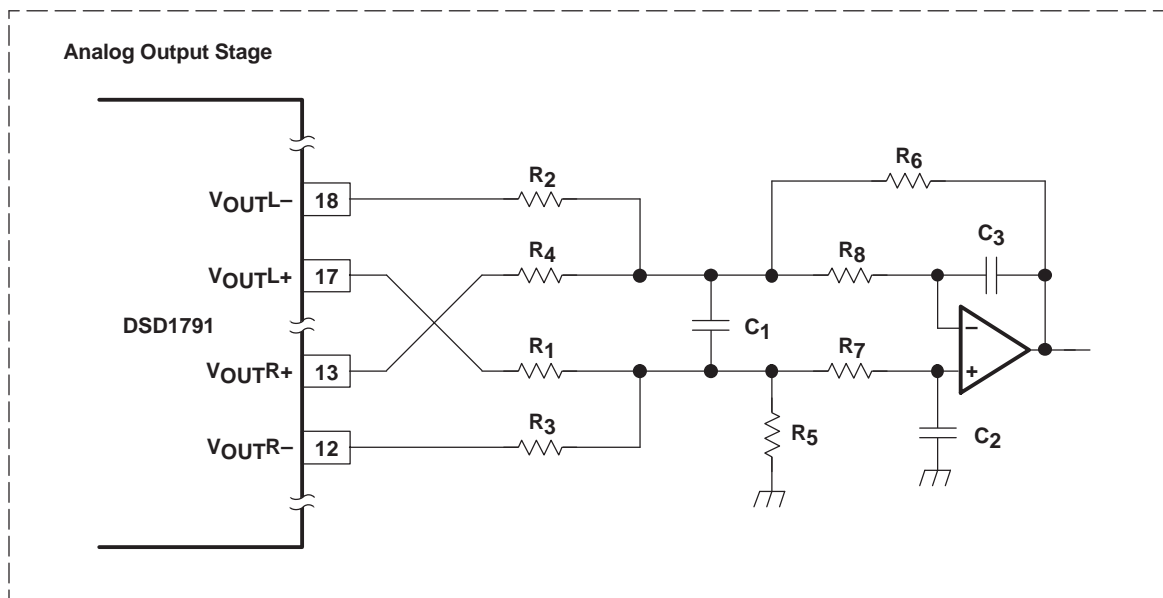
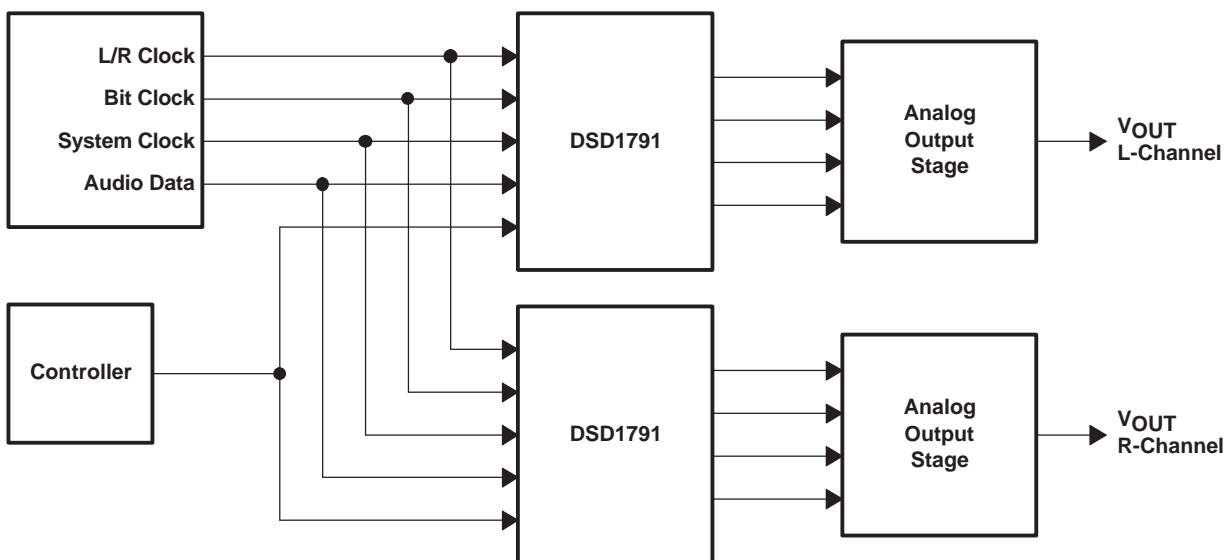

NOTE: Example R and C values for $f_c = 77$ kHz, R1–R4: 3.6 k Ω , R5, R6: 3.3 k Ω , R7, R8: 680 Ω , C1: 1800 pF, C2, C3: 560 pF.

Figure 34. Connection Diagram for Monaural Mode Interface

APPLICATION FOR EXTERNAL DIGITAL FILTER INTERFACE

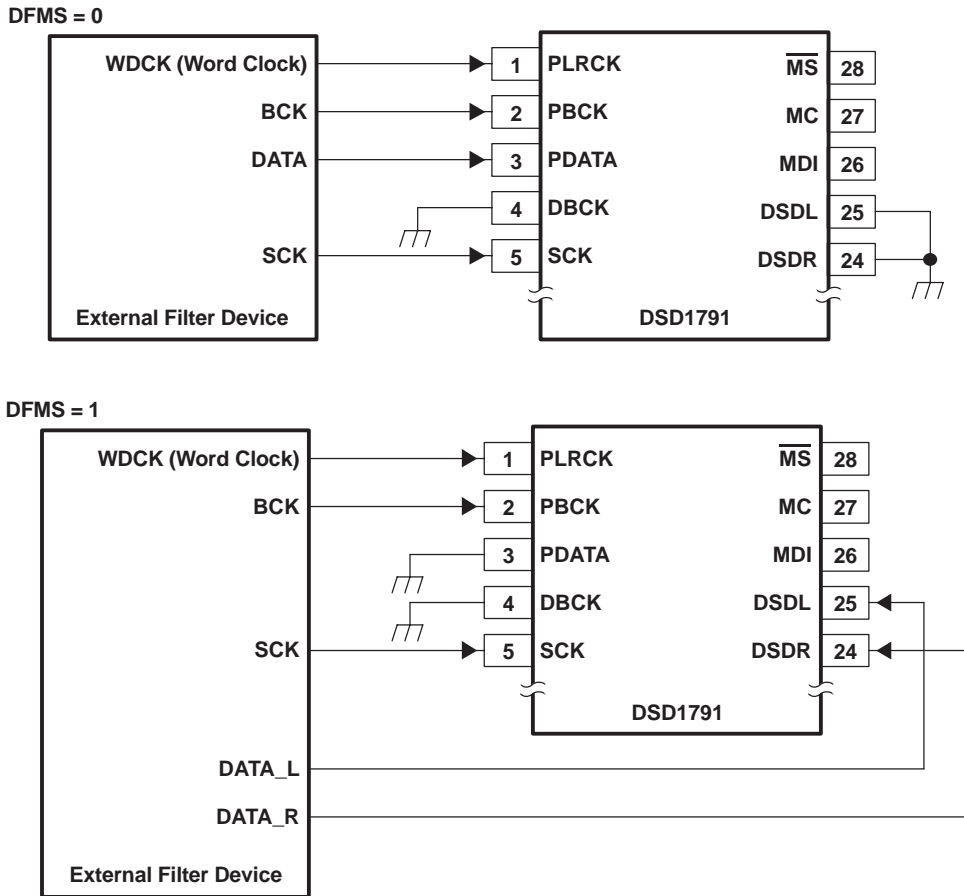

Figure 35. Connection Diagram for External Digital Filter (Internal DF Bypass Mode) Application

Application for Interfacing With an External Digital Filter

For some applications, it may be desirable to use an external digital filter to perform the interpolation function, as it can provide improved stop-band attenuation when compared to the internal digital filter of the DSD1791.

The DSD1791 supports several external digital filters, including:

- Texas Instruments DF1704 and DF1706
- Pacific Microsonics PMD200 HDCD filter/decoder IC
- Programmable digital signal processors

The external digital filter application mode is accessed by programming the following bit in the corresponding control register:

- DFTH = 1 (register 20)

The pins used to provide the serial interface for the external digital filter are shown in the connection diagram of Figure 35. The word clock (WDCK) signal must be operated at 8× or 4× the desired sampling frequency, f_s .

Pin Assignments When Using the External Digital Filter Interface

- PLRCK (pin 1): WDCK as word clock input
- PBCK (pin 2): BCK as bit clock for audio data
- PDATA (pin 3): DATA as monaural audio data input when the DFMS bit is not set to 1
- DSDL (pin 25): DATAL as L-channel audio data input when the DFMS bit is set to 1
- DSDR (pin 26): DATAR as R-channel audio data input when the DFMS bit is set to 1

Audio Format

The DSD1791 in the external digital filter interface mode supports right-justified audio formats including 16-bit, 20-bit, and 24-bit audio data, as shown in Figure 36. The audio format is selected by the FMT[2:0] bits of control register 18.

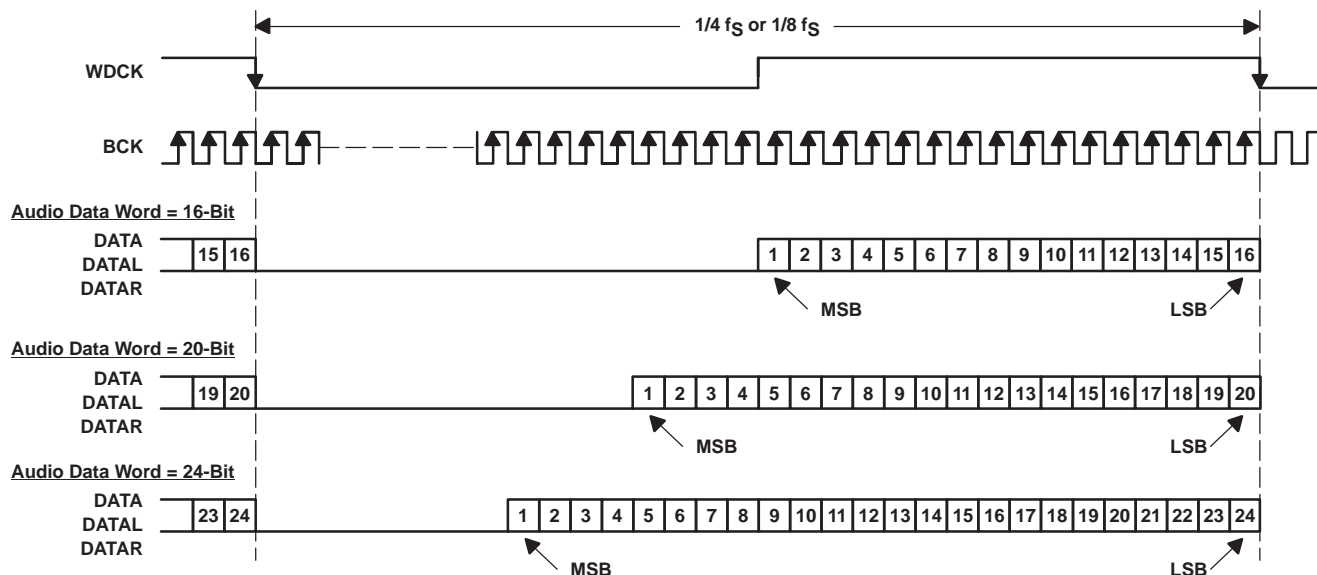
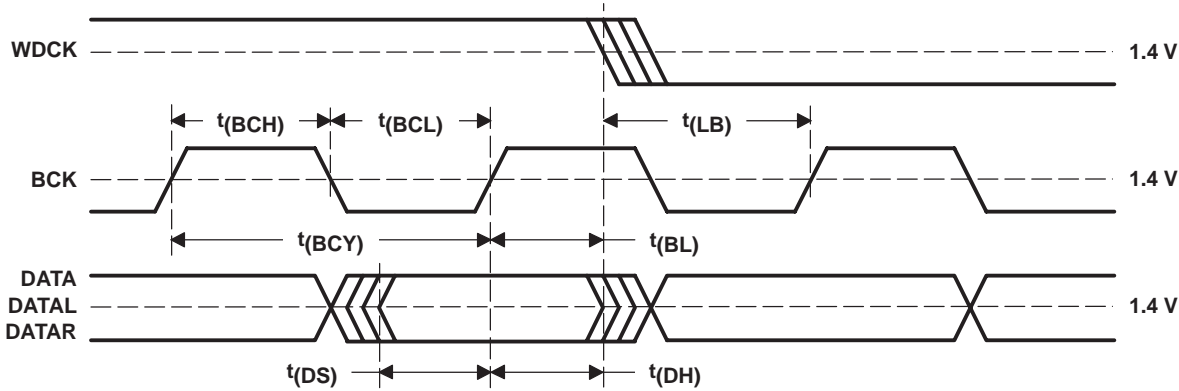

Figure 36. Audio Data Input Format for External Digital Filter (Internal DF Bypass Mode) Application

System Clock (SCK) and Interface Timing

The DSD1791 in an application using an external digital filter requires the synchronization of WDCK and the system clock. The system clock is phase-free with respect to WDCK. Interface timing among WDCK, BCK, DATA, DATAL, and DATAR is shown in Figure 37.



PARAMETER	MIN	MAX	UNITS
t(BCY) BCK pulse cycle time	20		ns
t(BCL) BCK pulse duration, LOW	7		ns
t(BCH) BCK pulse duration, HIGH	7		ns
t(BL) BCK rising edge to WDCK falling edge	5		ns
t(LB) WDCK falling edge to BCK rising edge	5		ns
t(DS) DATA, DATAL, DATAR setup time	5		ns
t(DH) DATA, DATAL, DATAR hold time	5		ns

Figure 37. Audio Interface Timing for External Digital Filter (Internal DF Bypass Mode) Application

Functions Available in the External Digital Filter Mode

The external digital filter mode allows access to the majority of the DSD1791 mode control functions.

The following table shows the register mapping available when the external digital filter mode is selected, along with descriptions of functions which are modified when using this mode selection.

	B15	B14	B13	B12	B11	B10	B9	B8	B7	B6	B5	B4	B3	B2	B1	B0
Register 16	R/W	0	0	1	0	0	0	0	–	–	–	–	–	–	–	–
Register 17	R/W	0	0	1	0	0	0	1	–	–	–	–	–	–	–	–
Register 18	R/W	0	0	1	0	0	1	0	–	FMT2	FMT1	FMT0	–	–	–	–
Register 19	R/W	0	0	1	0	0	1	1	REV	–	–	OPE	MDOE	DFMS	–	INZD
Register 20	R/W	0	0	1	0	1	0	0	–	SRST	0	1	MONO	CHSL	OS1	OS0
Register 21	R/W	0	0	1	0	1	0	1	–	–	–	–	–	–	–	PCMZ
Register 22	R	0	0	1	0	1	1	0	–	–	–	–	–	–	ZFGR	ZFGL

NOTE: –: Function is disabled. No operation even if data bit is set

FMT[2:0]: Audio Data Format Selection

Default value: 000

FMT[2:0]	Audio Data Format Select
000	16-bit right-justified format (default)
001	20-bit right-justified format
010	24-bit right-justified format
Other	N/A

OS[1:0]: Delta-Sigma Modulator Oversampling Rate Selection

Default value: 00

OS[1:0]	Operation Speed Select
00	8 times WDCK (default)
01	4 times WDCK
10	16 times WDCK
11	Reserved

The effective oversampling rate is determined by the oversampling performed by both the external digital filter and the delta-sigma modulator. For example, if the external digital filter is 8× oversampling, and the user selects OS[1:0] = 00, then the delta-sigma modulator oversamples by 8×, resulting in an effective oversampling rate of 64×. The 16× WDCK oversampling rate is not available above a 100-kHz sampling rate. If the oversampling rate selected is 16× WDCK, the system clock frequency must be over 256 f_S.

APPLICATION FOR DSD FORMAT (DSD MODE) INTERFACE

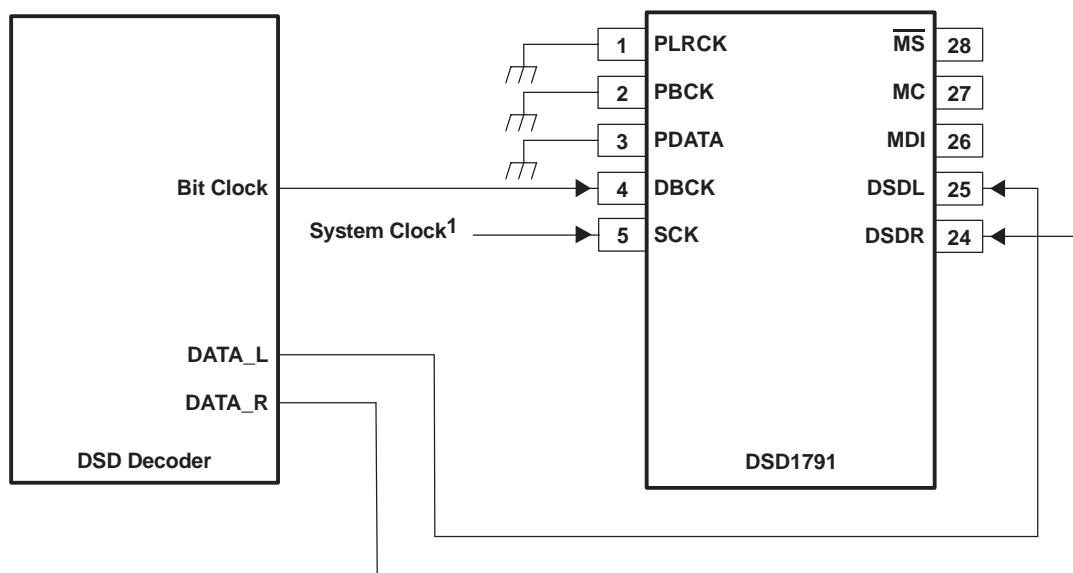

(1) The system clock can be removed after the register setting to the DSD mode.

Figure 38. Connection Diagram in DSD Mode

Feature

This mode is used for interfacing directly to a DSD decoder, which is found in Super Audio CD™ (SACD) applications. The DSD mode is available by programming the following bit in the corresponding control register:

- DSD = 1 (register 20)

The DSD mode provides a low-pass filtering function. The filtering is provided using an analog FIR filter structure. Four FIR responses are available and are selected by the DMF[1:0] bits of control register 18.

Pin Assignment When Using the DSD Format Interface

- DSDL (pin 25): L-channel DSD data input
- DSDR (pin 24): R-channel DSD data input
- DBCK (pin 4): Bit clock (BCK) for DSD data

Requirements for System Clock

The bit clock (DBCK) for the DSD mode is required at pin 4 of the DSD1791. The frequency of the bit clock may be N times the sampling frequency. Generally, N is 64 in DSD applications.

The interface timing between the bit clock and DSDL and DSDR is required to meet the setup and hold time specifications shown in Figure 40.

The SCK is not necessary after the mode change to the DSD mode is done.

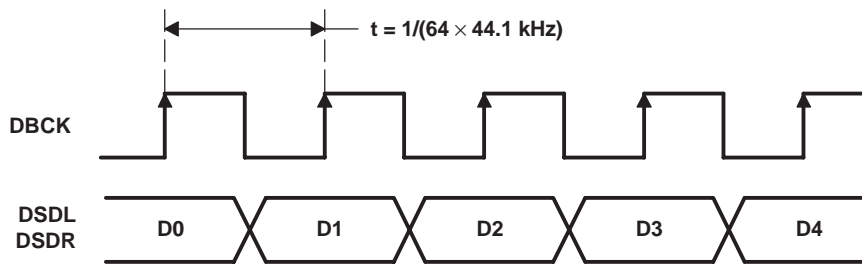
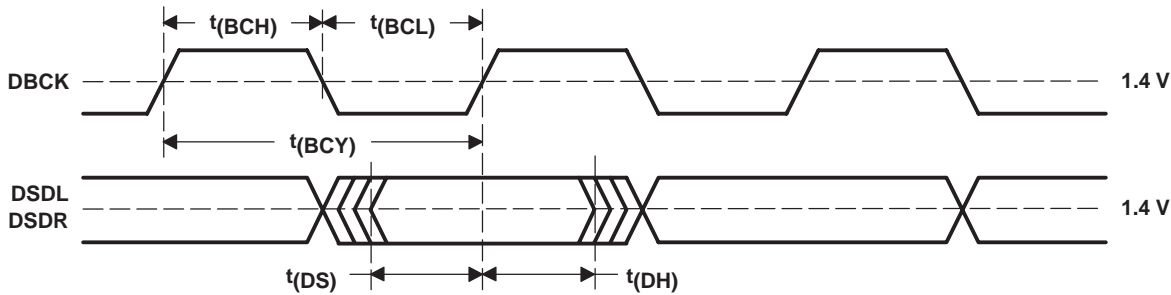

Figure 39. Normal Data Output Form From DSD Decoder



PARAMETER	MIN	MAX	UNITS
t(BCY) DBCK pulse cycle time	85 ⁽¹⁾		ns
t(BCH) DBCK high-level time	30		ns
t(BCL) DBCK low-level time	30		ns
t(DS) DSDL, DSDR setup time	10		ns
t(DH) DSDL, DSDR hold time	10		ns

⁽¹⁾ 2.8224 MHz × 4. (2.8224 MHz = 64 × 44.1 kHz. This value is specified as a sampling rate of DSD.)

Figure 40. Timing for DSD Audio Interface

ANALOG FIR FILTER PERFORMANCE IN DSD MODE

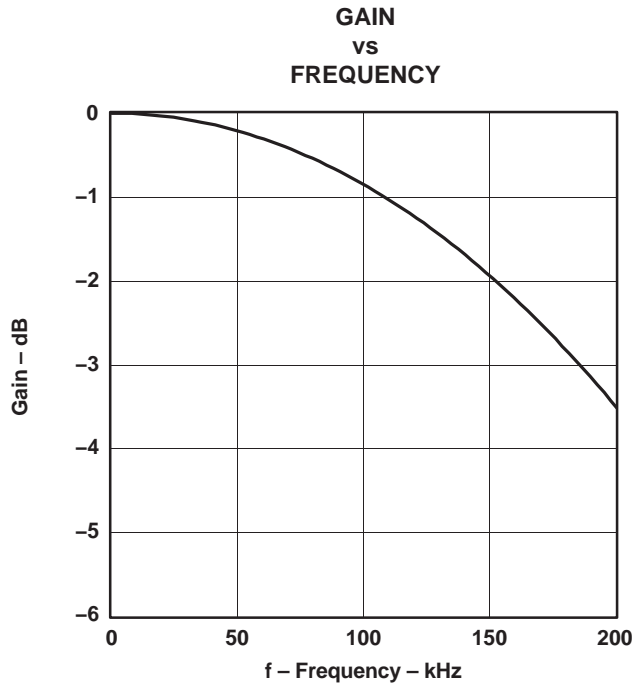

Figure 41. DSD Filter-1, Low BW

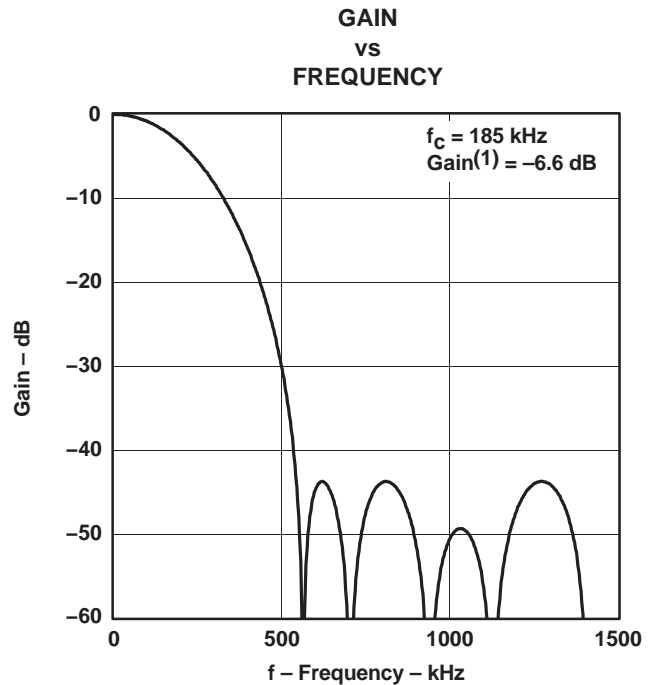

Figure 42. DSD Filter-1, High BW

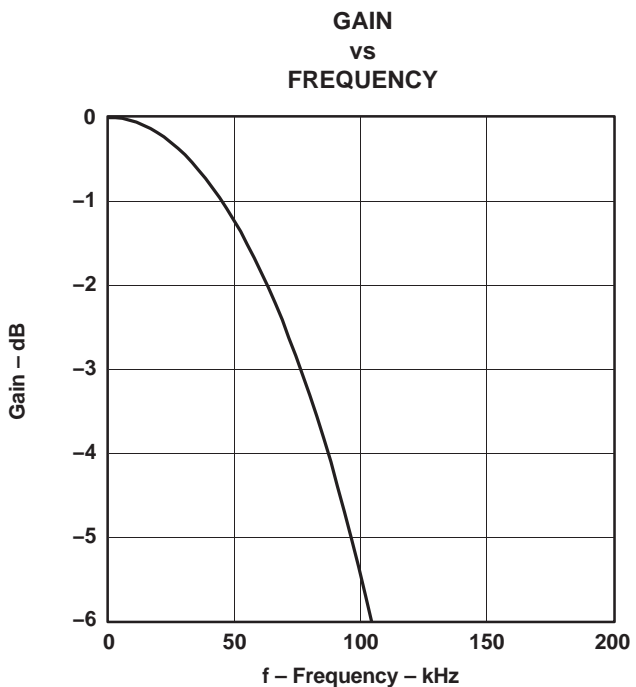

Figure 43. DSD Filter-2, Low BW

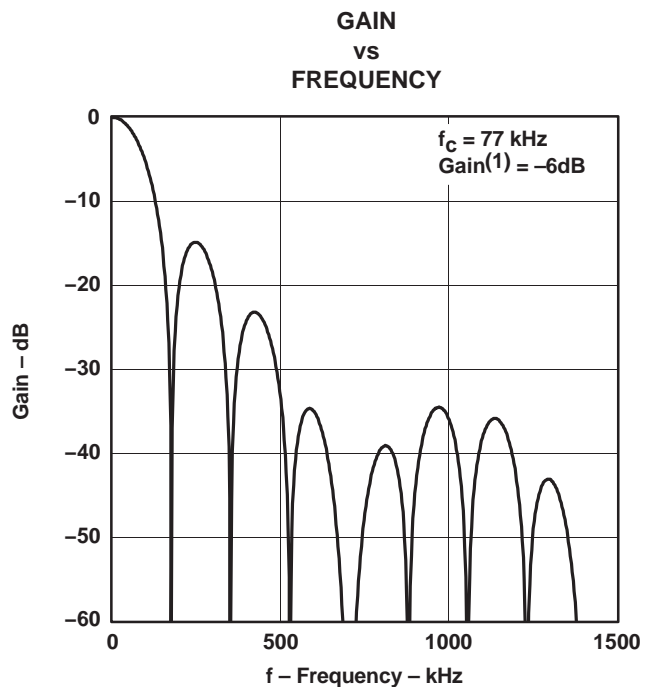

Figure 44. DSD Filter-2, High BW

(1) This gain is in comparison to PCM 0 dB, when the DSD input signal efficiency is 50%.

ANALOG FIR FILTER PERFORMANCE IN DSD MODE (CONTINUED)

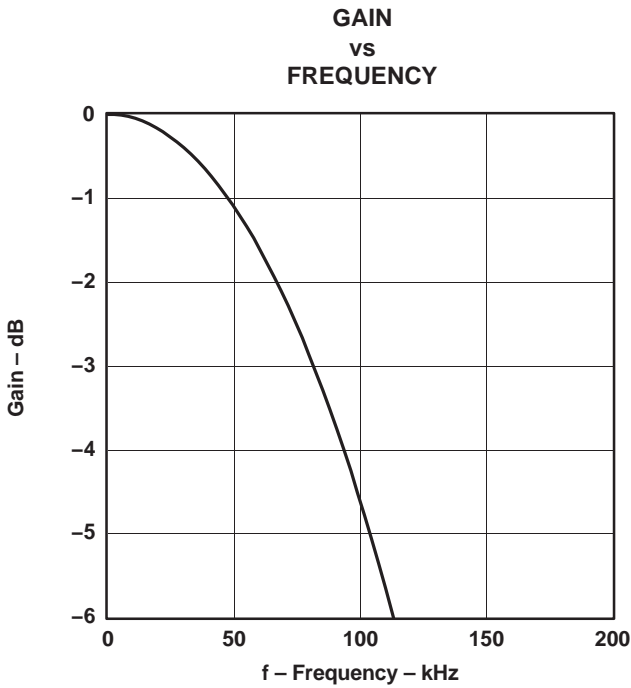

Figure 45. DSD Filter-3, Low BW

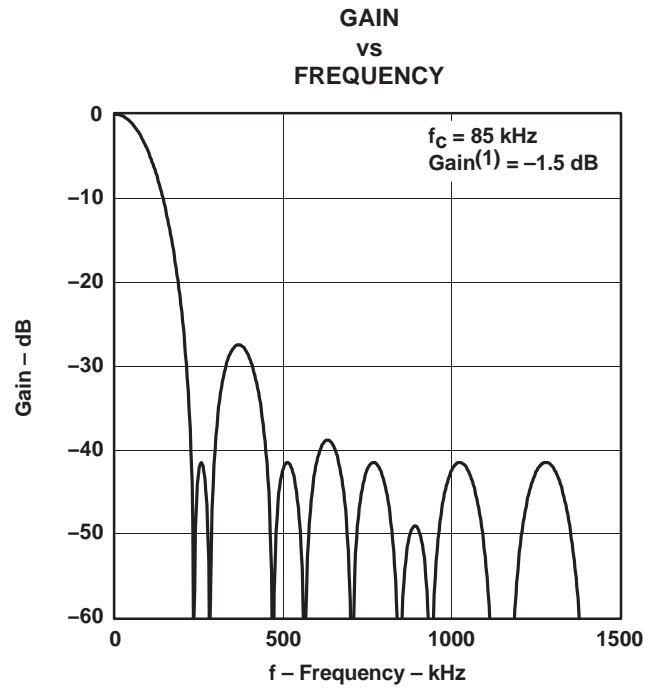

Figure 46. DSD Filter-3, High BW

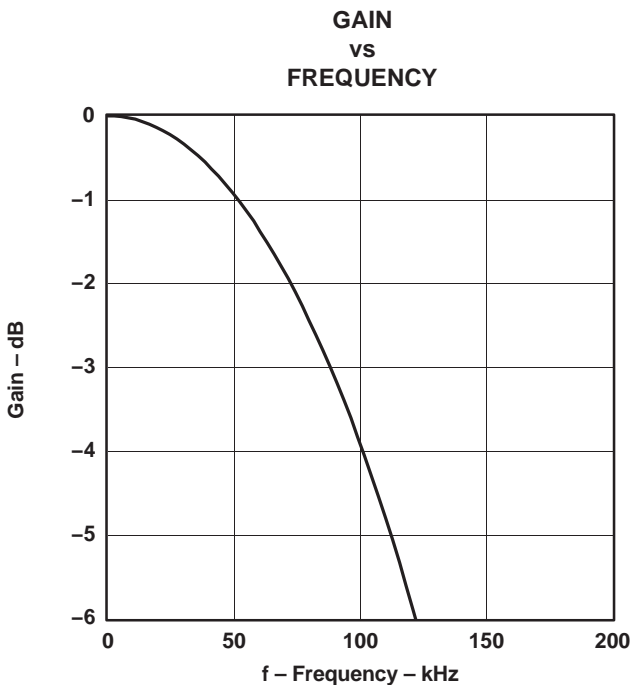

Figure 47. DSD Filter-4, Low BW

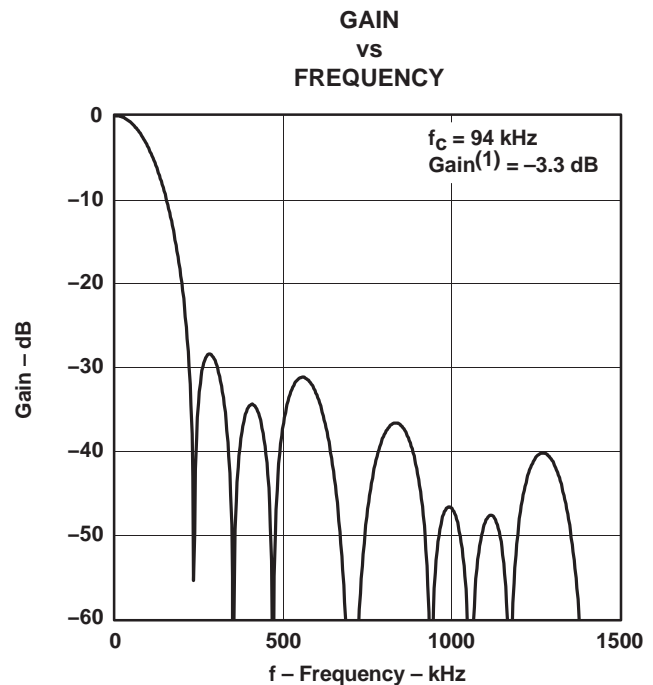

Figure 48. DSD Filter-4, High BW

(1) This gain is in comparison to PCM 0 dB, when the DSD input signal efficiency is 50%.

DSD MODE CONFIGURATION AND FUNCTION CONTROLS

Configuration for the DSD Interface Mode

DSD = 1 (Register 20, B5)

	B15	B14	B13	B12	B11	B10	B9	B8	B7	B6	B5	B4	B3	B2	B1	B0
Register 16	R/W	0	0	1	0	0	0	0	–	–	–	–	–	–	–	–
Register 17	R/W	0	0	1	0	0	0	1	–	–	–	–	–	–	–	–
Register 18	R/W	0	0	1	0	0	1	0	–	–	–	–	DMF1	DMF0	–	–
Register 19	R/W	0	0	1	0	0	1	1	REV	–	–	OPE	MDOE	–	–	–
Register 20	R/W	0	0	1	0	1	0	0	–	SRST	1	–	MONO	CHSL	OS1	OS0
Register 21	R	0	0	1	0	1	0	1	–	–	–	–	–	DZ1	DZ0	–
Register 22	R	0	0	1	0	1	1	0	–	–	–	–	–	–	ZFGR	ZFGL

NOTE: –: Function is disabled. No operation even if data bit is set

DMF[1:0]: Analog FIR Performance Selection

Default value: 00

DMF[1:0]	Analog FIR Performance Select
00	FIR-1 (default)
01	FIR-2
10	FIR-3
11	FIR-4

Plots for the four analog FIR filter responses are shown in the *ANALOG FIR FILTER PERFORMANCE IN DSD MODE* section of this data sheet.

OS[1:0]: Analog FIR Operation Speed Selection

Default value: 00

OS[1:0]	Operation Speed Select
00	f_{DBCK} (default)
01	$f_{DBCK}/2$
10	Reserved
11	$f_{DBCK}/4$

The OS bits in the DSD mode select the operating rate of the analog FIR. The OS bits must be set before setting the DSD bit to 1.

TDMCA INTERFACE FORMAT

The DSD1791 supports the time-division-multiplexed command and audio (TDMCA) data format to simplify the host control serial interface. The TDMCA format is designed not only for the McBSP of TI DSPs but also for any programmable devices. The TDMCA format can transfer not only audio data but also command data, so that it can be used together with any kind of device that supports the TDMCA format. The TDMCA frame consists of a command field, extended command field, and some audio data fields. Those audio data are transported to IN devices (such as a DAC) and/or from OUT devices (such as an ADC). The DSD1791 is an IN device. LRCK and BCK are used with both IN and OUT devices so that the sample frequency of all devices in a system must be the same. The TDMCA mode supports a maximum of 30 device IDs. The maximum number of audio channels depends on the BCK frequency.

TDMCA Mode Determination

The DSD1791 recognizes the TDMCA mode automatically when it receives an LRCK signal with a pulse duration of two BCK clocks. If TDMCA-mode operation is not needed, the duty cycle of LRCK must be 50%. Figure 49 shows the LRCK and BCK timing that determines the TDMCA mode. The DSD1791 enters the TDMCA mode after two continuous TDMCA frames. Any TDMCA commands can be issued during the next TDMCA frame after the TDMCA mode is entered.

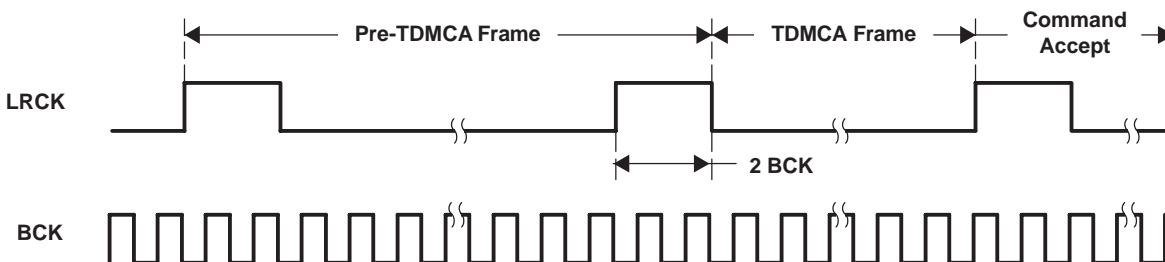

Figure 49. LRCK and BCK Timing for Determination of TDMCA Mode

TDMCA Terminals

TDMCA requires six signals, four of which are for command and audio data interface, and one pair of signals which are for daisy chaining. Those signals can be shared as in the following table. The DO signal has a 3-state output so that it can be connected directly to other devices.

TERMINAL NAME	TDMCA NAME	I/O	DESCRIPTION
PLRCK	LRCK	input	TDMCA frame start signal. It must be the same as the sampling frequency.
PBCK	BCK	input	TDMCA clock. Its frequency must be high enough to communicate a TDMCA frame within an LRCK cycle.
PDATA	DI	input	TDMCA command and audio data input signal
MDI	DO	output	TDMCA command data 3-state output signal
MC	DCI	input	TDMCA daisy-chain input signal
\overline{MS}	DCO	output	TDMCA daisy-chain output signal

Device ID Determination

The TDMCA mode also supports a multichip implementation in one system. This means a host controller (DSP) can simultaneously support several TDMCA devices, which can be of the same type or different types, including PCM devices. The PCM devices are categorized as IN device, OUT device, IN/OUT device, and NO device. The IN device has an input port to receive audio data, the OUT device has an output port to supply audio data, the IN/OUT device has both input and output ports for audio data, and the NO device has no port for audio data but needs command data from the host. A DAC is an IN device, an ADC is an OUT device, a codec is an IN/OUT device, and a PLL is a NO device. The DSD1791 is an IN device. For the host controller to distinguish the devices, each device is assigned its own device ID by the daisy chain. The devices obtain their own device IDs automatically by connecting their DCI to the DCO of the preceding device and their DCO to the DCI of the following device in the daisy chain. The daisy chains are categorized as the IN chain and the OUT chain, which are completely independent and equivalent. Figure 50 shows an example daisy chain connection. If a system needs to chain the DSD1791 and a NO device in the same IN or OUT chain, the NO device must be chained at the back end of the chain because it does not require any audio data. Figure 51 shows an example of TDMCA system including an IN chain and an OUT chain with a TI DSP. For a device to get its own device ID, the DID signal must be set to 1 (see the *Command Field* section for details), and LRCK and BCK must be driven in the TDMCA mode for all PCM devices which are chained. The device at the top of the chain knows its device ID is 1 because its DCI is fixed HIGH. Other devices count the BCK pulses and observe their own DCI signal to determine their position and ID. Figure 52 shows the initialization of each device ID.

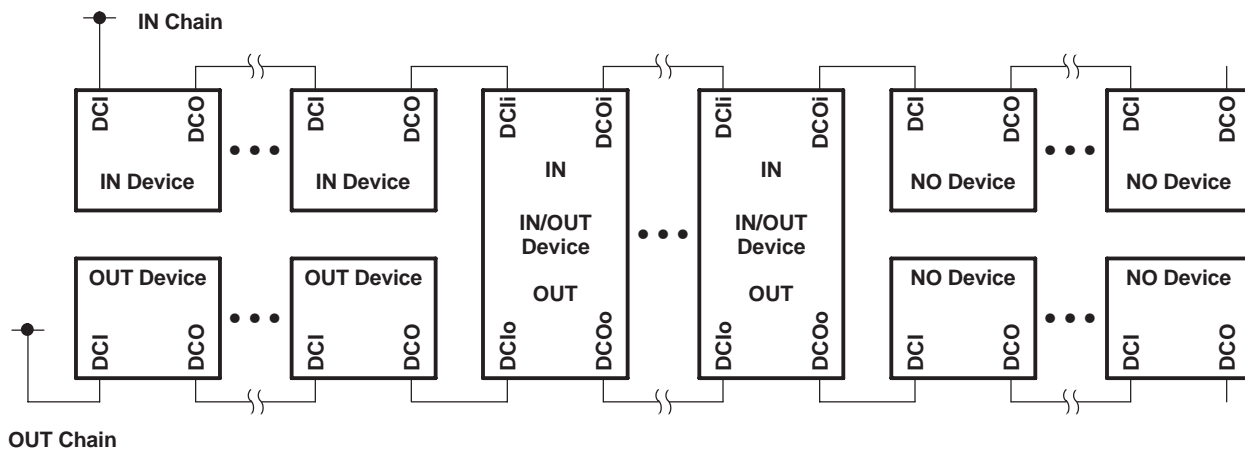

Figure 50. Daisy Chain Connection

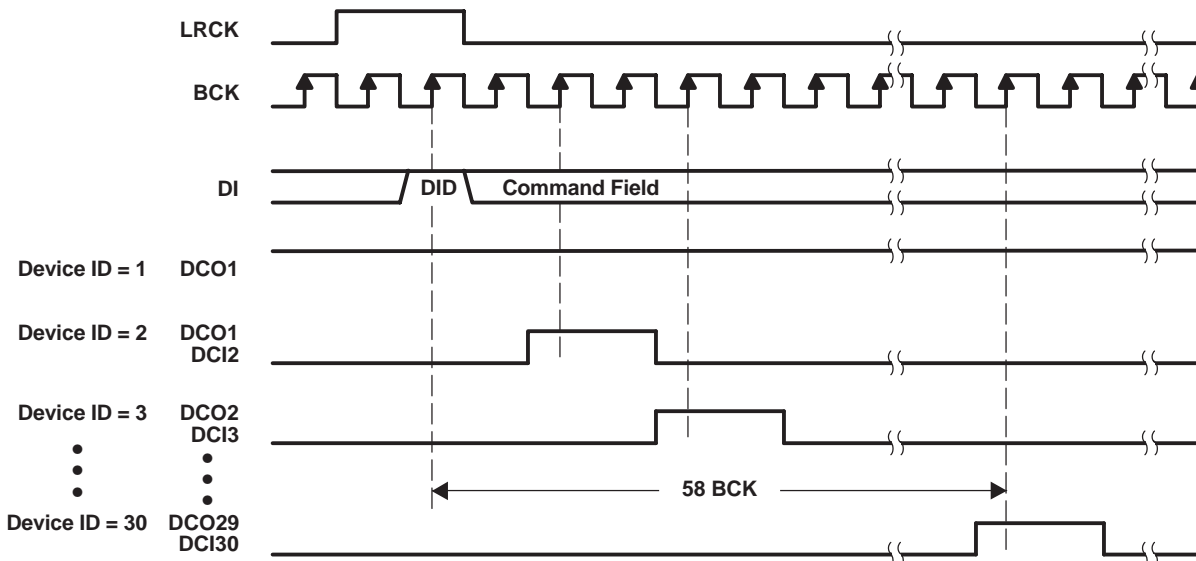

Figure 52. Device ID Determination Sequence

TDMCA Frame

In general, the TDMCA frame consists of the command field, extended command (EMD) field, and audio data fields. All of them are 32 bits in length, but the lowest byte has no meaning. The MSB is transferred first for each field. The command field is always transferred as the first packet of the frame. The EMD field is transferred if the EMD flag of the command field is HIGH. If any EMD packets are transferred, no audio data follows the EMD packets. This frame is for quick system initialization. All devices of a daisy chain should respond to the command field and extended command field. The DSD1791 has two audio channels that can be selected by OPE (register 19). If this OPE bit is not set to HIGH, those audio channels are transferred. Figure 53 shows the general TDMCA frame. If some DACs are enabled, but corresponding audio data packets are not transferred, the analog outputs are unpredictable.

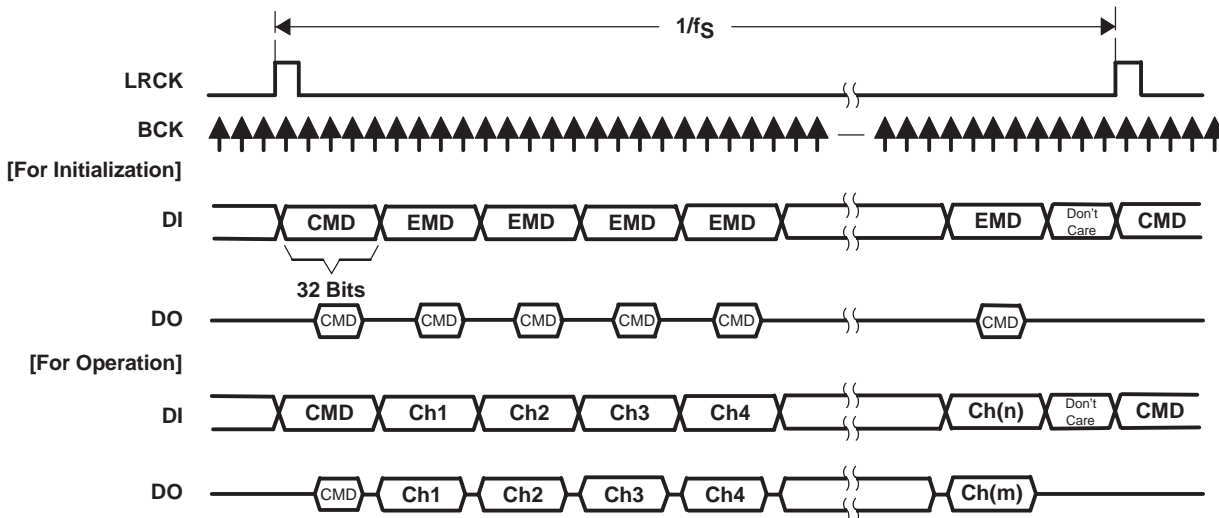

Figure 53. General TDMCA Frame

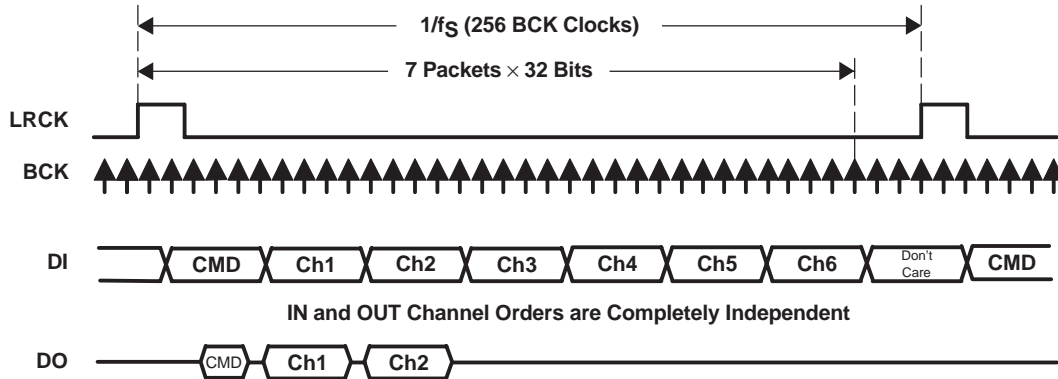

Figure 54. TDMCA Frame Example of 6-Ch DAC and 2-Ch ADC With Command Read

Command Field

The normal command field is defined as follows. When the DID bit (MSB) is 1, this frame is used only for device ID determination, and all remaining bits in the field are ignored.

	31	30	29	28	24	23	22	16	15	8	7	0
command	DID	EMD	DCS	device ID	R/W	register ID	data	not used				

Bit 31: Device ID Enable Flag

The DSD1791 operates to get its own device ID for TDMCA initialization if this bit is HIGH.

Bit 30: Extended Command Enable Flag

An EMD packet is transferred if this bit is HIGH, otherwise skipped. Once it is HIGH, this frame does not contain any audio data. This is for system initialization.

Bit 29: Daisy Chain Selection Flag

HIGH designates OUT-chain devices, LOW designates IN-chain devices. The DSD1791 is an IN device, so the DCS bit must be set to LOW.

Bits[28:24]: Device ID

The device ID is 5 bits length, and it can be defined. These bits identify the order of a device in the IN or OUT daisy chain. The top of the daisy chain defines device ID 1 and successive devices are numbered 2, 3, 4, etc. All devices for which the DCI is fixed HIGH are also defined as ID 1. The maximum device ID is 30 each in the IN and OUT chains. If a device ID of 0x1F is used, all devices are selected as broadcast when in the write mode. If a device ID of 0x00 is used, no device is selected.

Bit 23: Command Read/Write Flag

If this bit is HIGH, the command is a read operation.

Bits[22:16]: Register ID

It is 7 bits in length.

Bits[15:8]: Command Data

It is 8 bits in length. Any valid data can be chosen for each register.

Bits[7:0]: Not Used

These bits are never transported when a read operation is performed.

Extended Command Field

The extended command field is the same as the command field, except that it does not have a DID flag.

	31	30	29	28	24	23	22	16	15	8	7	0
extended command	rsvd	EMD	DCS	device ID	R/W	register ID	data	not used				

Audio Fields

The audio field is 32 bits in length and the audio data is transferred MSB first, so the other fields must be stuffed with 0s as shown in the following example.

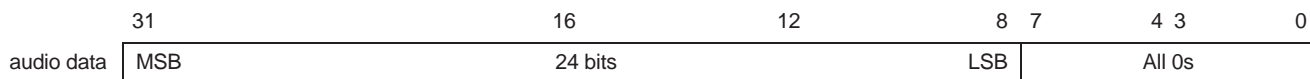

TDMCA Register Requirements

TDMCA mode requires device ID and audio channel information, previously described. The OPE bit in register 19 indicates audio channel availability and register 23 indicates the device ID. Register 23 is used only in the TDMCA mode. See the mode control register map (Table 4).

Register Write/Read Operation

The command supports register write and read operations. If the command requests to read one register, the read data is transferred on DO during the data phase of the timing cycle. The DI signal can be retrieved at the positive edge of BCK, and the DO signal is driven at the negative edge of BCK. DO is activated one BCK cycle early to compensate for the output delay caused by high impedance. Figure 55 shows the TDMCA write and read timing.

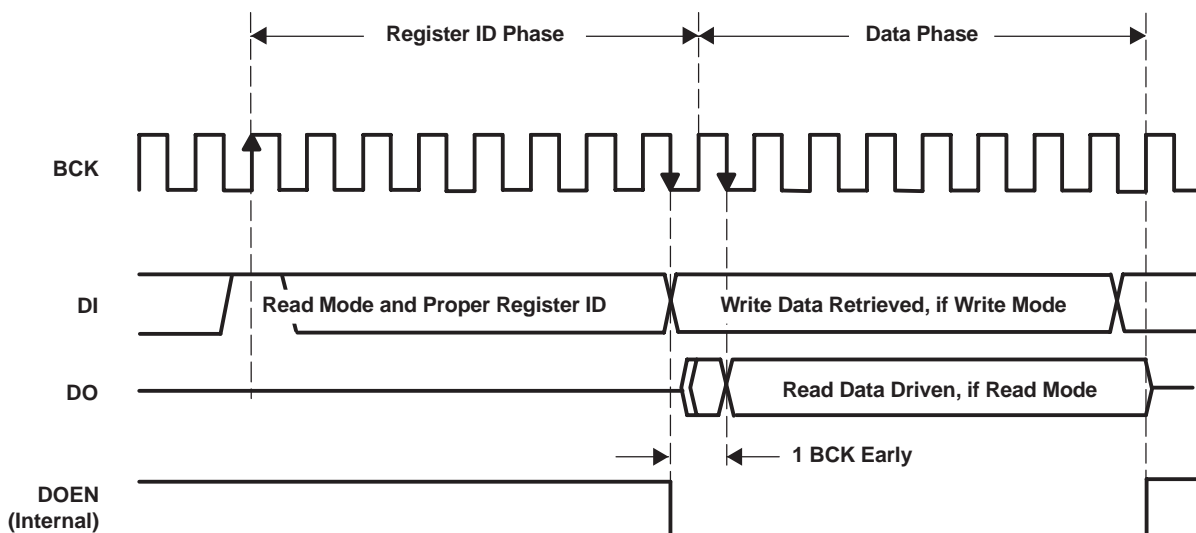

Figure 55. TDMCA Write and Read Operation Timing

TDMCA-Mode Operation

DCO specifies the owner of the next audio channel in TDMCA-mode operation. When a device retrieves its own audio channel data, DCO goes HIGH during the last audio channel period. Figure 56 shows the DCO output timing in TDMCA-mode operation. The host controller ignores the behavior of DCI and DCO. DCO indicates the last audio channel of each device. Therefore, DCI means the next audio channel is allocated.

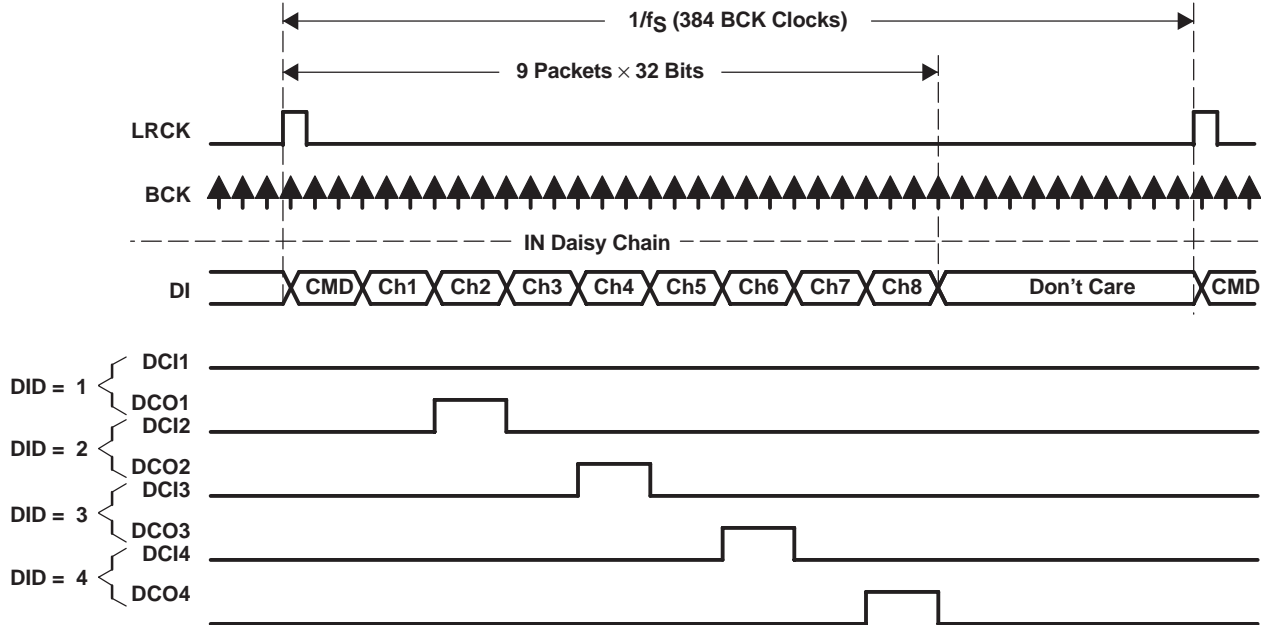

Figure 56. DCO Output Timing for TDMCA Mode Operation

If some devices are skipped due to no active audio channel, the skipped devices must notify the next device that the DCO is being passed through the next DCI. Figure 57 and Figure 58 show DCO timing with skip operation. Figure 59 shows the ac timing of the daisy chain signals.

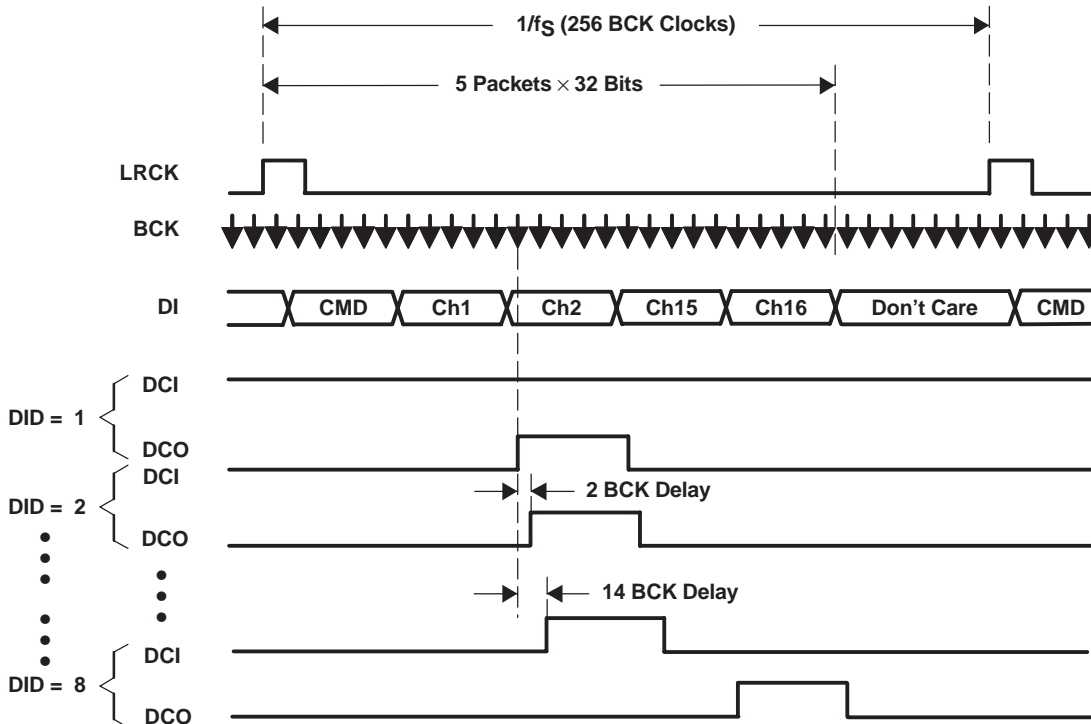

Figure 57. DCO Output Timing With Skip Operation

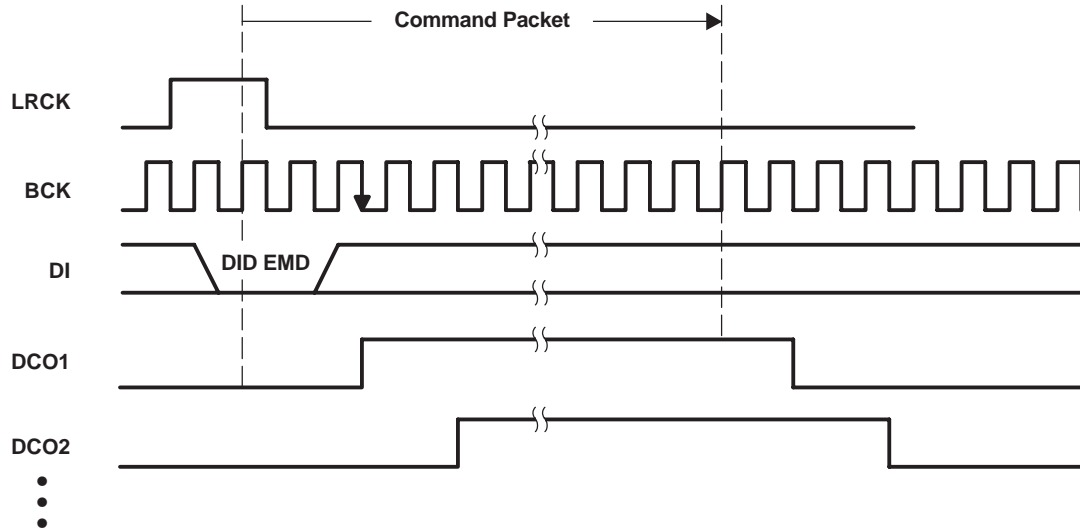
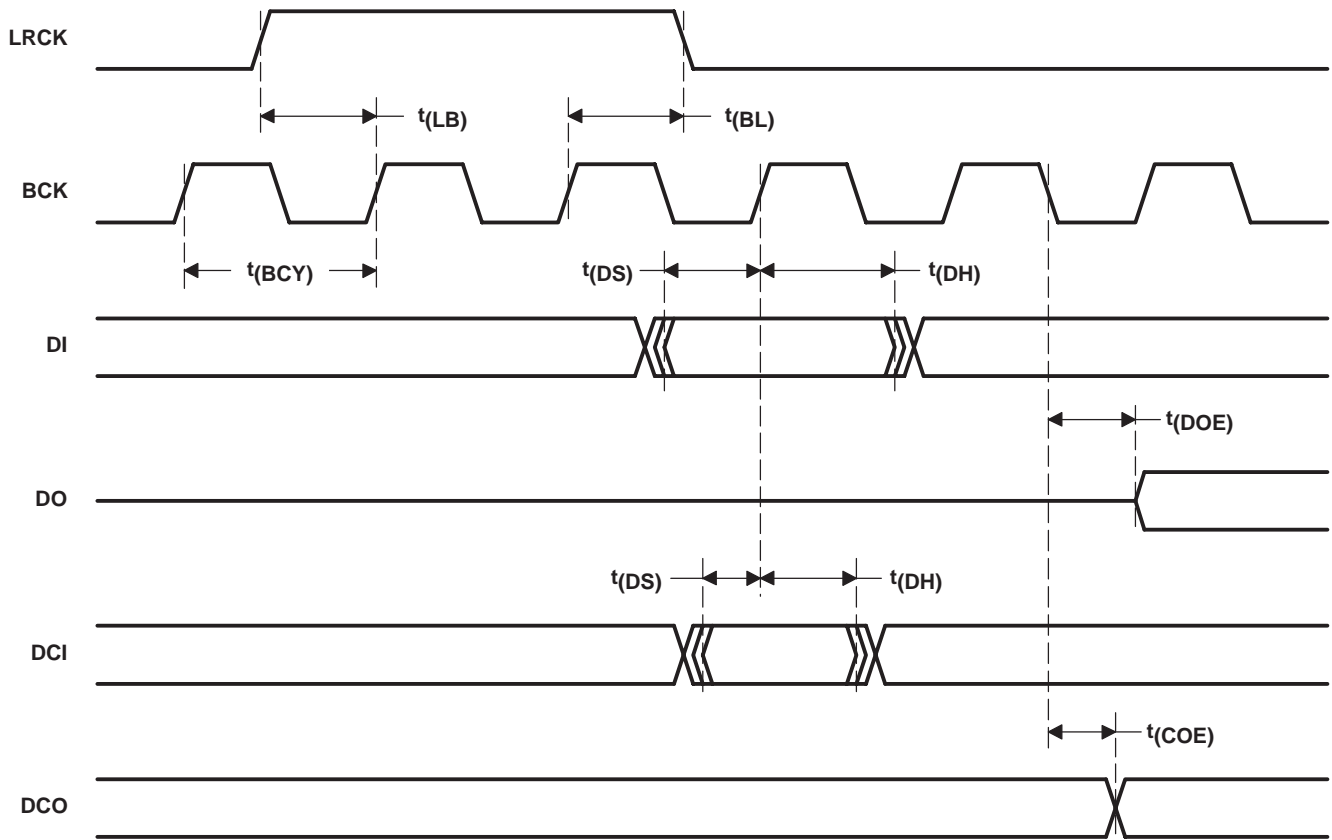

Figure 58. DCO Output Timing With Skip Operation (for Command Packet 1)



PARAMETER		MIN	MAX	UNITS
$t(BCY)$	BCK pulse cycle time	20		ns
$t(LB)$	LRCK setup time	0		ns
$t(BL)$	LRCK hold time	3		ns
$t(DS)$	DI setup time	0		ns
$t(DH)$	DI hold time	3		ns
$t(DS)$	DCI setup time	0		ns
$t(DH)$	DCI hold time	3		ns
$t(DOE)$	DO output delay ⁽¹⁾		8	ns
$t(COE)$	DCO output delay ⁽¹⁾		6	ns

⁽¹⁾ Load capacitance is 10 pF.

Figure 59. AC Timing of Daisy Chain Signals

THEORY OF OPERATION

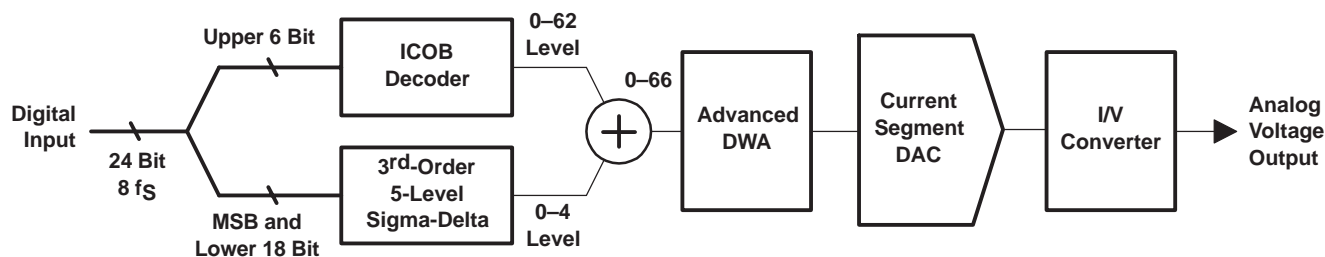

Figure 60. Advanced Segment DAC With I/V Converter

The DSD1791 uses TI’s advanced segment DAC architecture to achieve excellent dynamic performance and improved tolerance to clock jitter. The DSD1791 provides balanced voltage outputs.

Digital input data via the digital filter is separated into 6 upper bits and 18 lower bits. The 6 upper bits are converted to inverted complementary offset binary (ICOB) code. The lower 18 bits, in association with the MSB, are processed by a five-level third-order delta-sigma modulator operated at $64 f_s$ by default. The 1 level of the modulator is equivalent to the 1 LSB of the ICOB code converter. The data groups processed in the ICOB converter and third-order delta-sigma modulator are summed together to an up to 66-level digital code, and then processed by data-weighted averaging (DWA) to reduce the noise produced by element mismatch. The data of up to 66 levels from the DWA is converted to an analog output in the differential-current segment section.

This architecture has overcome the various drawbacks of conventional multibit processing and also achieves excellent dynamic performance.

CONSIDERATIONS FOR APPLICATION CIRCUITS

PCB Layout Guidelines

A typical PCB floor plan for the DSD1791 is shown in Figure 61. A ground plane is recommended, with the analog and digital sections being isolated from one another using a split or cut in the circuit board. The DSD1791 must be oriented with the digital I/O pins facing the ground plane split/cut to allow for short, direct connections to the digital audio interface and control signals originating from the digital section of the board. Separate power supplies are recommended for the digital and analog sections of the board. This prevents the switching noise present on the digital supply from contaminating the analog power supply and degrading the dynamic performance of the D/A converters. In cases where a common 5 V supply would be used for the analog and digital sections, an inductance (RF choke, ferrite bead) must be placed between the analog and digital 5-V supply connections to avoid coupling of the digital switching noise into the analog circuitry. Figure 62 shows the recommended approach for single-supply applications.

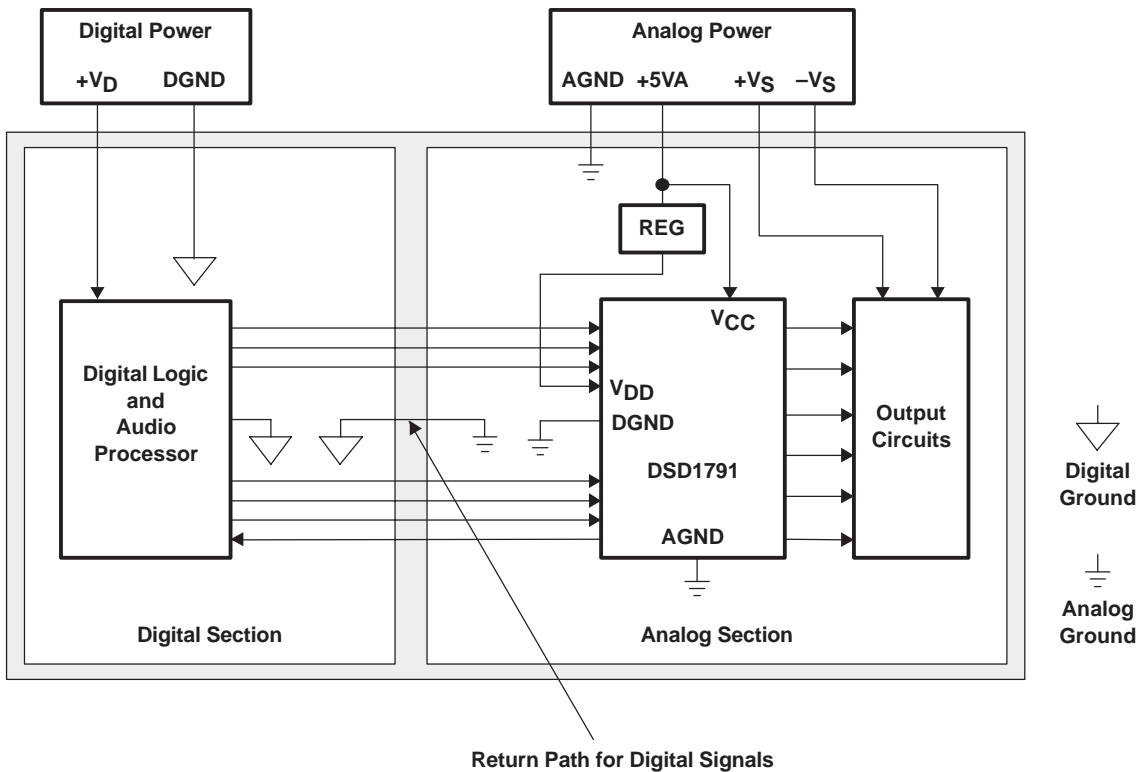

Figure 61. Recommended PCB Layout

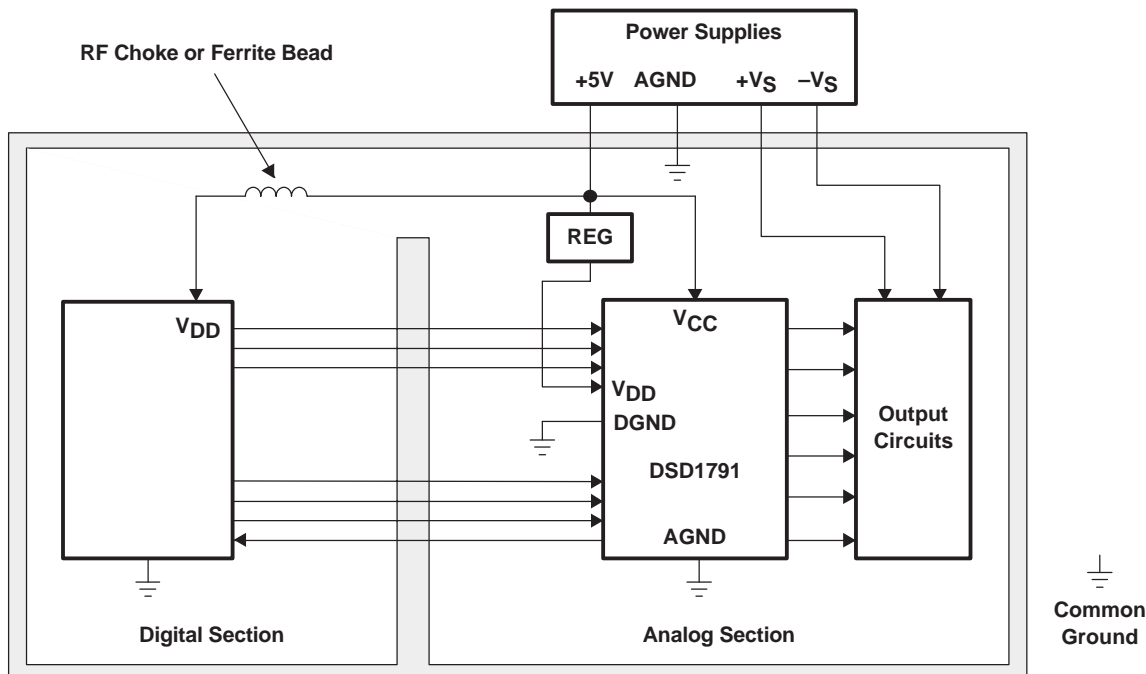

Figure 62. Single-Supply PCB Layout

Bypass and Decoupling Capacitor Requirements

Various-sized decoupling capacitors can be used, with no special tolerances being required. All capacitors must be located as close as possible to the appropriate pins of the DSD1791 to reduce noise pickup from surrounding circuitry. Aluminum electrolytic capacitors that are designed for hi-fi audio applications are recommended for larger values, while metal film or monolithic ceramic capacitors are used for smaller values.

Post-LPF Design

By proper choice of the operational amplifier and resistors used in the post-LPF circuit, excellent performance of the DSD1791 can be achieved. To obtain 0.001% THD+N, 113 dB signal-to-noise-ratio audio performance, the THD+N and input noise performance of the operational amplifier should be considered. This is because the input noise of the operational amplifier contributes directly to the output noise level of the application. The V_{OUT} pin of the DSD1791 and the input resistor of the post-LPF circuit must be connected as closely as possible.

Out-of-band noise level and attenuated sampling spectrum level are much lower than for typical delta-sigma type DACs due to the combination of a high-performance digital filter and advanced segment DAC architecture. The use of a second-order or third-order post-LPF is recommended for the post-LPF of the DSD1791. The cutoff frequency of the post-LPF depends on the application. For example, there are many sampling-rate operations such as $f_S = 44.1$ kHz on CDDA, $f_S = 96$ kHz on DVD-M, $f_S = 192$ kHz on DVD-A, $f_S = 64 f_S$ on DSD (SACD).

PACKAGING INFORMATION

Orderable part number	Status (1)	Material type (2)	Package Pins	Package qty Carrier	RoHS (3)	Lead finish/ Ball material (4)	MSL rating/ Peak reflow (5)	Op temp (°C)	Part marking (6)
DSD1791DB	Active	Production	SSOP (DB) 28	47 TUBE	Yes	NIPDAU	Level-1-260C-UNLIM	-25 to 85	DSD1791
DSD1791DB.B	Active	Production	SSOP (DB) 28	47 TUBE	Yes	NIPDAU	Level-1-260C-UNLIM	-25 to 85	DSD1791
DSD1791DBR	Active	Production	SSOP (DB) 28	2000 LARGE T&R	Yes	NIPDAU	Level-1-260C-UNLIM	-25 to 85	DSD1791
DSD1791DBR.B	Active	Production	SSOP (DB) 28	2000 LARGE T&R	Yes	NIPDAU	Level-1-260C-UNLIM	-25 to 85	DSD1791

(1) **Status:** For more details on status, see our [product life cycle](#).

(2) **Material type:** When designated, preproduction parts are prototypes/experimental devices, and are not yet approved or released for full production. Testing and final process, including without limitation quality assurance, reliability performance testing, and/or process qualification, may not yet be complete, and this item is subject to further changes or possible discontinuation. If available for ordering, purchases will be subject to an additional waiver at checkout, and are intended for early internal evaluation purposes only. These items are sold without warranties of any kind.

(3) **RoHS values:** Yes, No, RoHS Exempt. See the [TI RoHS Statement](#) for additional information and value definition.

(4) **Lead finish/Ball material:** Parts may have multiple material finish options. Finish options are separated by a vertical ruled line. Lead finish/Ball material values may wrap to two lines if the finish value exceeds the maximum column width.

(5) **MSL rating/Peak reflow:** The moisture sensitivity level ratings and peak solder (reflow) temperatures. In the event that a part has multiple moisture sensitivity ratings, only the lowest level per JEDEC standards is shown. Refer to the shipping label for the actual reflow temperature that will be used to mount the part to the printed circuit board.

(6) **Part marking:** There may be an additional marking, which relates to the logo, the lot trace code information, or the environmental category of the part.

Multiple part markings will be inside parentheses. Only one part marking contained in parentheses and separated by a "~" will appear on a part. If a line is indented then it is a continuation of the previous line and the two combined represent the entire part marking for that device.

Important Information and Disclaimer: The information provided on this page represents TI's knowledge and belief as of the date that it is provided. TI bases its knowledge and belief on information provided by third parties, and makes no representation or warranty as to the accuracy of such information. Efforts are underway to better integrate information from third parties. TI has taken and continues to take reasonable steps to provide representative and accurate information but may not have conducted destructive testing or chemical analysis on incoming materials and chemicals. TI and TI suppliers consider certain information to be proprietary, and thus CAS numbers and other limited information may not be available for release.

In no event shall TI's liability arising out of such information exceed the total purchase price of the TI part(s) at issue in this document sold by TI to Customer on an annual basis.

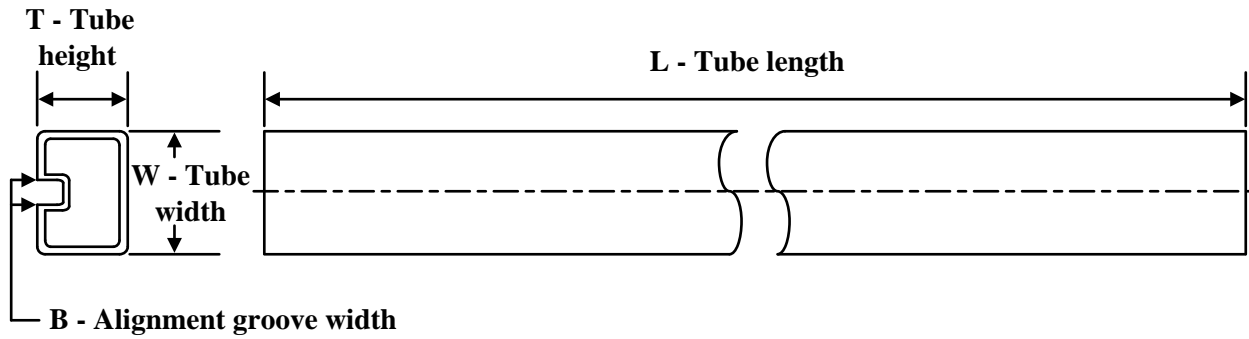
TUBE

*All dimensions are nominal

Device	Package Name	Package Type	Pins	SPQ	L (mm)	W (mm)	T (μm)	B (mm)
DSD1791DB	DB	SSOP	28	47	500	10.6	500	9.6
DSD1791DB.B	DB	SSOP	28	47	500	10.6	500	9.6

EXAMPLE BOARD LAYOUT

DB0028A

SSOP - 2 mm max height

SMALL OUTLINE PACKAGE

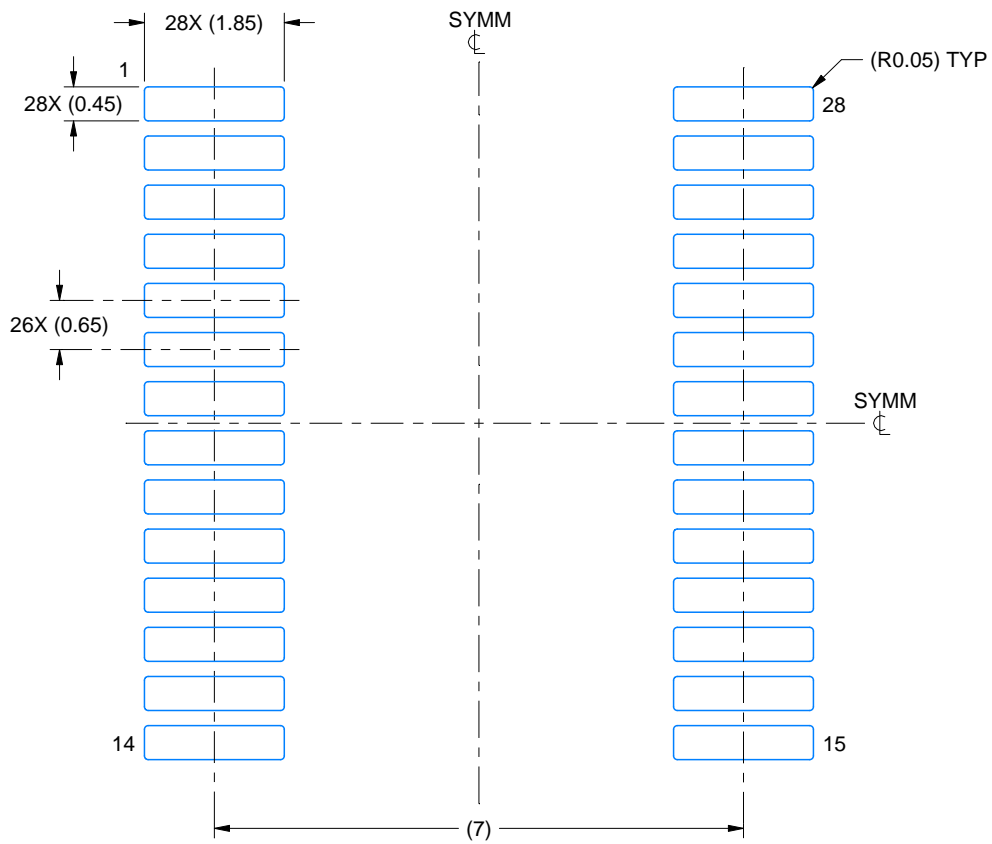

LAND PATTERN EXAMPLE
EXPOSED METAL SHOWN
SCALE: 10X

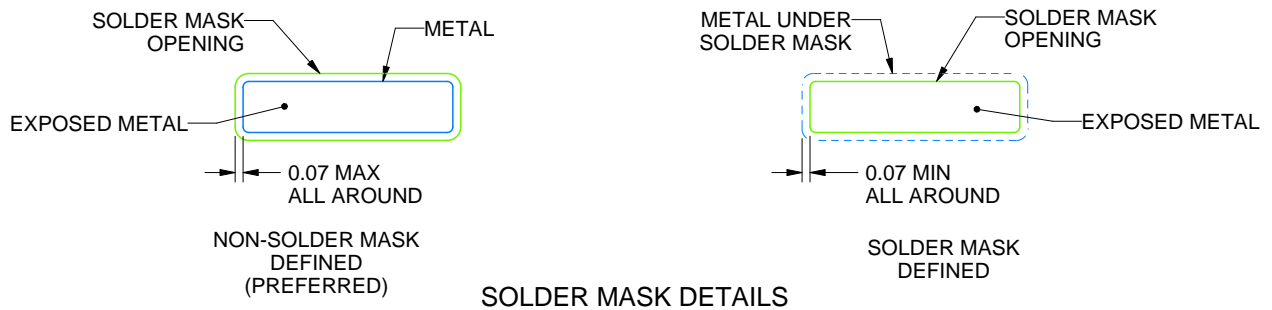

4214853/B 03/2018

NOTES: (continued)

- 6. Publication IPC-7351 may have alternate designs.
- 7. Solder mask tolerances between and around signal pads can vary based on board fabrication site.

EXAMPLE STENCIL DESIGN

DB0028A

SSOP - 2 mm max height

SMALL OUTLINE PACKAGE

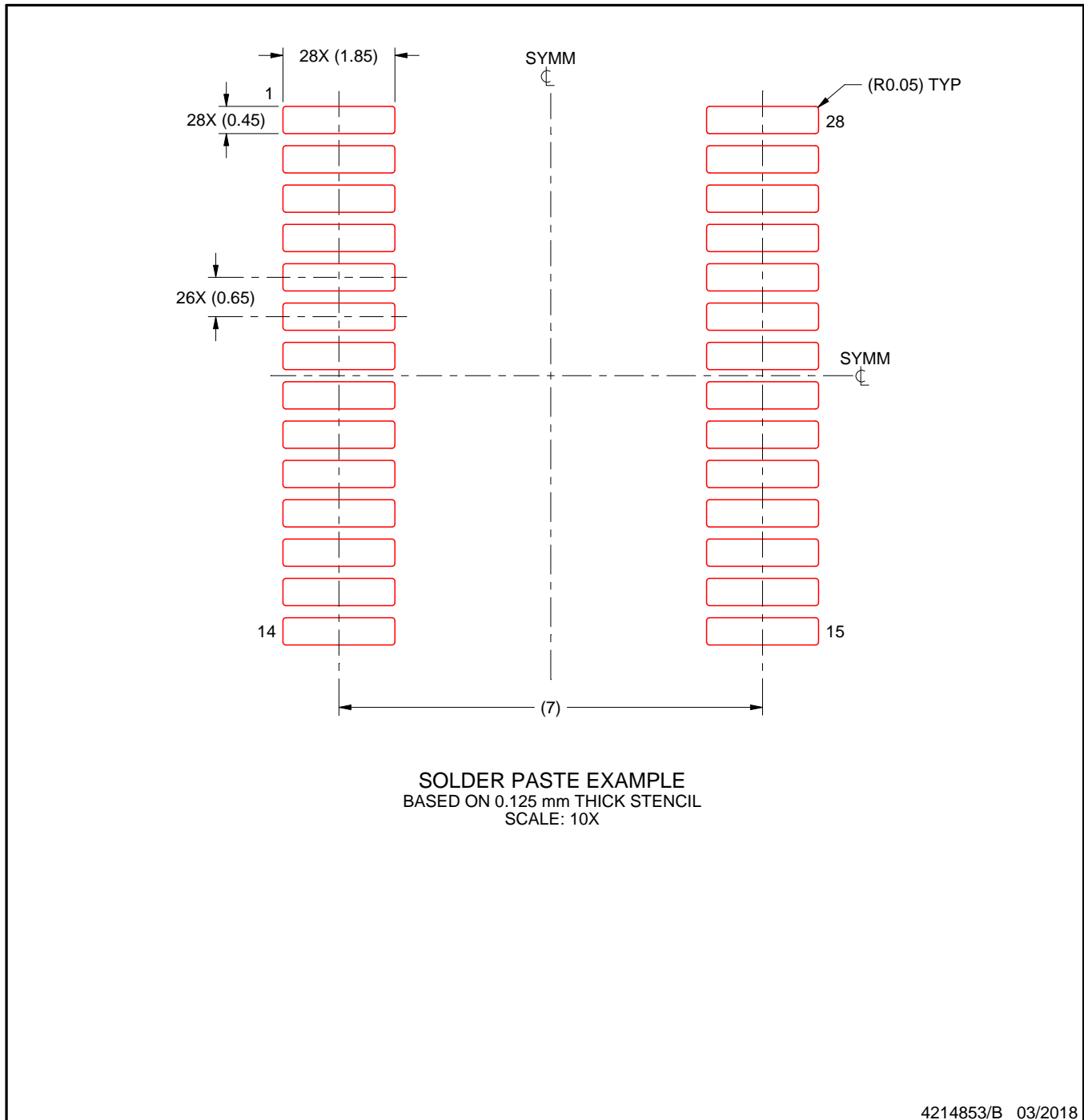

NOTES: (continued)

8. Laser cutting apertures with trapezoidal walls and rounded corners may offer better paste release. IPC-7525 may have alternate design recommendations.
9. Board assembly site may have different recommendations for stencil design.

IMPORTANT NOTICE AND DISCLAIMER

TI PROVIDES TECHNICAL AND RELIABILITY DATA (INCLUDING DATASHEETS), DESIGN RESOURCES (INCLUDING REFERENCE DESIGNS), APPLICATION OR OTHER DESIGN ADVICE, WEB TOOLS, SAFETY INFORMATION, AND OTHER RESOURCES "AS IS" AND WITH ALL FAULTS, AND DISCLAIMS ALL WARRANTIES, EXPRESS AND IMPLIED, INCLUDING WITHOUT LIMITATION ANY IMPLIED WARRANTIES OF MERCHANTABILITY, FITNESS FOR A PARTICULAR PURPOSE OR NON-INFRINGEMENT OF THIRD PARTY INTELLECTUAL PROPERTY RIGHTS.

These resources are intended for skilled developers designing with TI products. You are solely responsible for (1) selecting the appropriate TI products for your application, (2) designing, validating and testing your application, and (3) ensuring your application meets applicable standards, and any other safety, security, regulatory or other requirements.

These resources are subject to change without notice. TI grants you permission to use these resources only for development of an application that uses the TI products described in the resource. Other reproduction and display of these resources is prohibited. No license is granted to any other TI intellectual property right or to any third party intellectual property right. TI disclaims responsibility for, and you fully indemnify TI and its representatives against any claims, damages, costs, losses, and liabilities arising out of your use of these resources.

TI's products are provided subject to [TI's Terms of Sale](#), [TI's General Quality Guidelines](#), or other applicable terms available either on ti.com or provided in conjunction with such TI products. TI's provision of these resources does not expand or otherwise alter TI's applicable warranties or warranty disclaimers for TI products. Unless TI explicitly designates a product as custom or customer-specified, TI products are standard, catalog, general purpose devices.

TI objects to and rejects any additional or different terms you may propose.

Copyright © 2026, Texas Instruments Incorporated

Last updated 10/2025