



Precision, Rail-to-Rail I/O INSTRUMENTATION AMPLIFIER

FEATURES

- **PRECISION**
 - LOW OFFSET: 100 μ V (max)
 - LOW OFFSET DRIFT: 0.4 μ V/ $^{\circ}$ C (max)
 - EXCELLENT LONG-TERM STABILITY
 - VERY-LOW 1/f NOISE
- **TRUE RAIL-TO-RAIL I/O**
 - INPUT COMMON-MODE RANGE:
 - 20mV Below Negative Rail to 100mV Above Positive Rail
 - WIDE OUTPUT SWING: Within 10mV of Rails
 - SUPPLY RANGE: Single +2.7V to +5.5V
- **SMALL SIZE**
 - microPACKAGE: MSOP-8, MSOP-10
- **LOW COST**

APPLICATIONS

- **LOW-LEVEL TRANSDUCER AMPLIFIER FOR BRIDGES, LOAD CELLS, THERMOCOUPLES**
- **WIDE DYNAMIC RANGE SENSOR MEASUREMENTS**
- **HIGH-RESOLUTION TEST SYSTEMS**
- **WEIGH SCALES**
- **MULTI-CHANNEL DATA ACQUISITION SYSTEMS**
- **MEDICAL INSTRUMENTATION**
- **GENERAL-PURPOSE**

DESCRIPTION

The INA326 and INA327 (with shutdown) are high-performance, low-cost, precision instrumentation amplifiers with rail-to-rail input and output. They are true single-supply instrumentation amplifiers with very low DC errors and input common-mode ranges that extends beyond the positive and negative rails. These features make them suitable for applications ranging from general-purpose to high-accuracy.

Excellent long-term stability and very low 1/f noise assure low offset voltage and drift throughout the life of the product.

The INA326 (without shutdown) comes in the MSOP-8 package. The INA327 (with shutdown) is offered in an MSOP-10. Both are specified over the industrial temperature range, -40° C to $+85^{\circ}$ C, with operation from -40° C to $+125^{\circ}$ C.

INA326 AND INA327 RELATED PRODUCTS

| PRODUCT | FEATURES |
|---------|---|
| INA337 | Precision, 0.4 μ V/ $^{\circ}$ C Drift, Specified -40° C to $+125^{\circ}$ C |
| INA114 | 50 μ V V_{OS} , 0.5nA I_B , 115dB CMR, 3mA I_Q , 0.25 μ V/ $^{\circ}$ C Drift |
| INA118 | 50 μ V V_{OS} , 1nA I_B , 120dB CMR, 385 μ A I_Q , 0.5 μ V/ $^{\circ}$ C Drift |
| INA122 | 250 μ V V_{OS} , -10 nA I_B , 85 μ A I_Q , Rail-to-Rail Output, 3 μ V/ $^{\circ}$ C Drift |
| INA128 | 50 μ V V_{OS} , 2nA I_B , 125dB CMR, 750 μ A I_Q , 0.5 μ V/ $^{\circ}$ C Drift |
| INA321 | 500 μ V V_{OS} , 0.5pA I_B , 94dB CMRR, 60 μ A I_Q , Rail-to-Rail Output |

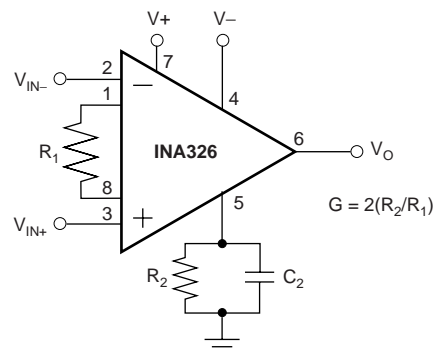

Please be aware that an important notice concerning availability, standard warranty, and use in critical applications of Texas Instruments semiconductor products and disclaimers thereto appears at the end of this data sheet.

PACKAGE/ORDERING INFORMATION⁽¹⁾

| PRODUCT | PACKAGE-LEAD | PACKAGE DESIGNATOR | SPECIFIED TEMPERATURE RANGE | PACKAGE MARKING | ORDERING NUMBER | TRANSPORT MEDIA, QUANTITY |
|-------------|--------------|--------------------|-----------------------------|-----------------|------------------------------|---|
| INA326 " | MSOP-8 " | DGK " | -40°C to +85°C " | B26 " | INA326EA/250 INA326EA/2K5 | Tape and Reel, 250 Tape and Reel, 2500 |
| INA327 " | MSOP-10 " | DGS " | -40°C to +85°C " | B27 " | INA327EA/250 INA327EA/2K5 | Tape and Reel, 250 Tape and Reel, 2500 |

NOTE: (1) For the most current package and ordering information, download the latest version of this data sheet and see the Package Option Addendum located at the end of the data sheet.

ABSOLUTE MAXIMUM RATINGS⁽¹⁾

| | |
|--|----------------------|
| Supply Voltage | +5.5V |
| Signal Input Terminals: Voltage ⁽²⁾ | -0.5V to (V+) + 0.5V |
| Current ⁽²⁾ | ±10mA |
| Output Short-Circuit | Continuous |
| Operating Temperature Range | -40°C to +125°C |
| Storage Temperature Range | -65°C to +150°C |
| Junction Temperature | +150°C |
| Lead Temperature (soldering, 10s) | +300°C |

NOTES: (1) Stresses above these ratings may cause permanent damage. Exposure to absolute maximum conditions for extended periods may degrade device reliability. These are stress ratings only, and functional operation of the device at these or any other conditions beyond those specified is not implied.
(2) Input terminals are diode clamped to the power-supply rails. Input signals that can swing more than 0.5V beyond the supply rails should be current limited to 10mA or less.



ELECTROSTATIC DISCHARGE SENSITIVITY

This integrated circuit can be damaged by ESD. Texas Instruments recommends that all integrated circuits be handled with appropriate precautions. Failure to observe proper handling and installation procedures can cause damage.

ESD damage can range from subtle performance degradation to complete device failure. Precision integrated circuits may be more susceptible to damage because very small parametric changes could cause the device not to meet its published specifications.

PIN CONFIGURATION

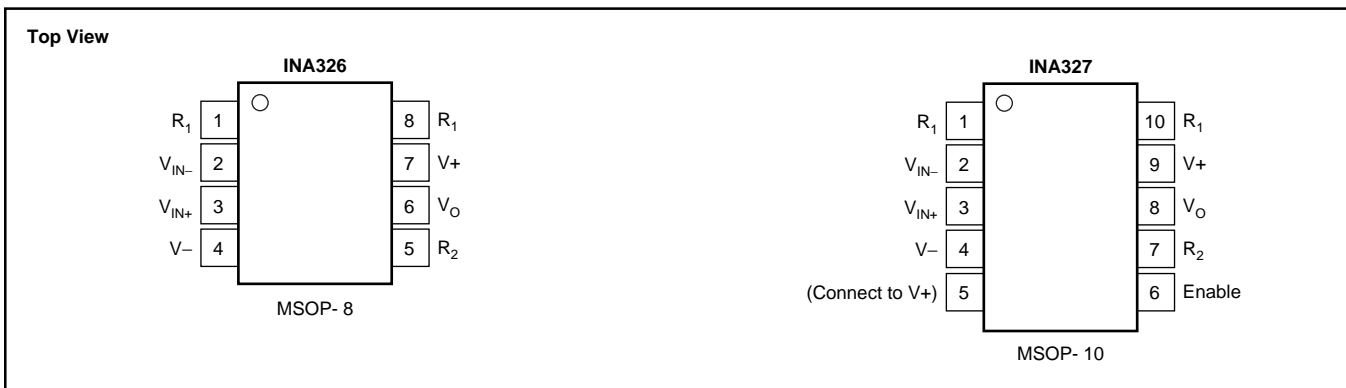

ELECTRICAL CHARACTERISTICS: $V_S = +2.7V$ to $+5.5V$

BOLDFACE limits apply over the specified temperature range, $T_A = -40^{\circ}C$ to $+85^{\circ}C$

At $T_A = +25^{\circ}C$, $R_L = 10k\Omega$, $G = 100$ ($R_1 = 2k\Omega$, $R_2 = 100k\Omega$), external gain set resistors, and $I_{A_{COMMON}} = V_S/2$, with external equivalent filter corner of 1kHz, unless otherwise noted.

| PARAMETER | CONDITION | INA326EA, INA327EA | | | UNITS |
|--|---|---|---|---|---|
| | | MIN | TYP | MAX | |
| INPUT | | | | | |
| Offset Voltage, RTI Over Temperature vs Temperature vs Power Supply Long-Term Stability Input Impedance, Differential Common-Mode | V_{OS} $V_S = +5V, V_{CM} = V_S/2$ dV_{OS}/dT PSR $V_S = +2.7V$ to $+5.5V, V_{CM} = V_S/2$ | | ± 20 ± 0.1 ± 3 See Note (1) $10^{10} \parallel 2$ $10^{10} \parallel 14$ | ± 100 ± 124 ± 0.4 | μV μV $\mu V/^{\circ}C$ $\mu V/V$ |
| Input Voltage Range Safe Input Voltage Common-Mode Rejection Over Temperature | CMR $V_S = +5V, V_{CM} = (V-) - 0.02V$ to $(V+) + 0.1V$ | (V-) - 0.02 (V-) - 0.5 100 94 | 114 | (V+) + 0.1 (V+) + 0.5 | $\Omega \parallel pF$ $\Omega \parallel pF$ V V dB dB |
| INPUT BIAS CURRENT | | | | | |
| Bias Current vs Temperature | I_B $V_{CM} = V_S/2$ $V_S = +5V$ | | ± 0.2 | ± 2 | nA |
| Offset Current | I_{OS} $V_S = +5V$ | | See Typical Characteristics | | nA |
| NOISE | | | | | |
| Voltage Noise, RTI f = 10Hz f = 100Hz f = 1kHz f = 0.01Hz to 10Hz | $R_S = 0\Omega, G = 100, R_1 = 2k\Omega, R_2 = 100k\Omega$ | | 33 33 33 0.8 | | nV/\sqrt{Hz} nV/\sqrt{Hz} nV/\sqrt{Hz} $\mu Vp-p$ |
| Voltage Noise, RTI f = 10Hz f = 100Hz f = 1kHz f = 0.01Hz to 10Hz | $R_S = 0\Omega, G = 10, R_1 = 20k\Omega, R_2 = 100k\Omega$ | | 120 97 97 4 | | nV/\sqrt{Hz} nV/\sqrt{Hz} nV/\sqrt{Hz} $\mu Vp-p$ |
| Current Noise, RTI f = 1kHz f = 0.01Hz to 10Hz | | | 0.15 4.2 | | pA/\sqrt{Hz} $pAp-p$ |
| Output Ripple, V_O Filtered ⁽²⁾ | | | See Applications Information | | |
| GAIN | | | | | |
| Gain Equation Range of Gain Gain Error ⁽³⁾ vs Temperature Nonlinearity | $G = 10, 100, V_S = +5V, V_O = 0.075V$ to $4.925V$ $G = 10, 100, V_S = +5V, V_O = 0.075V$ to $4.925V$ $G = 10, 100, V_S = +5V, V_O = 0.075V$ to $4.925V$ | < 0.1 | $G = 2(R_2/R_1)$ ± 0.08 ± 6 ± 0.004 | > 10000 ± 0.2 ± 25 ± 0.01 | V/V % ppm/^{\circ}C % of FS |
| OUTPUT | | | | | |
| Voltage Output Swing from Rail Over Temperature Capacitive Load Drive Short-Circuit Current | I_{SC} $R_L = 100k\Omega$ $R_L = 10k\Omega, V_S = +5V$ | 75 75 | 5 10 500 ± 25 | | mV mV mV pF mA |
| INTERNAL OSCILLATOR | | | | | |
| Frequency of Auto-Correction Accuracy | | | 90 ± 20 | | kHz % |
| FREQUENCY RESPONSE | | | | | |
| Bandwidth ⁽⁴⁾ , -3dB Slew Rate ⁽⁴⁾ Settling Time ⁽⁴⁾ , 0.1% 0.01% 0.1% 0.01% Overload Recovery ⁽⁴⁾ | BW SR t_s 1kHz Filter, $G = 1$ to $1k, V_O = 2V$ step, $C_L = 100pF$ 10kHz Filter, $G = 1$ to $1k, V_O = 2V$ step, $C_L = 100pF$ 1kHz Filter, 50% Output Overload, $G = 1$ to $1k$ 10kHz Filter, 50% Output Overload, $G = 1$ to $1k$ | $G = 1$ to $1k$ $V_S = +5V$, All Gains, $C_L = 100pF$ | 1 Filter Limited 0.95 1.3 130 160 30 5 | | kHz ms ms μs μs μs μs |

ELECTRICAL CHARACTERISTICS: $V_S = +2.7V$ to $+5.5V$ (Cont.)

BOLDFACE limits apply over the specified temperature range, $T_A = -40^{\circ}C$ to $+85^{\circ}C$

At $T_A = +25^{\circ}C$, $R_L = 10k\Omega$, $G = 100$ ($R_1 = 2k\Omega$, $R_2 = 100k\Omega$), external gain set resistors, and $I_{A_{COMMON}} = V_S/2$, with external equivalent filter corner of 1kHz, unless otherwise noted.

| PARAMETER | CONDITION | INA326EA, INA327EA | | | UNITS |
|---|--|--------------------|-----|------------|---------------|
| | | MIN | TYP | MAX | |
| POWER SUPPLY | | | | | |
| Specified Voltage Range | $I_O = 0$, Diff $V_{IN} = 0V$, $V_S = +5V$ | +2.7 | | +5.5 | V |
| Quiescent Current | | | 2.4 | 3.4 | mA |
| Over Temperature | | | | 3.7 | mA |
| SHUTDOWN | | | | | |
| Disable (Logic Low Threshold) | $V_S = +5V$, Disabled | 1.6 | | 0.25 | V |
| Enable (Logic High Threshold) | | | | | V |
| Enable Time ⁽⁵⁾ | | | 75 | | μs |
| Disable Time | | | 100 | | μs |
| Shutdown Current and Enable Pin Current | | | 2 | 5 | μA |
| TEMPERATURE RANGE | | | | | |
| Specified Range | MSOP-8, MSOP-10 Surface-Mount | -40 | | +85 | $^{\circ}C$ |
| Operating Range | | -40 | | +125 | $^{\circ}C$ |
| Storage Range | | -65 | | +150 | $^{\circ}C$ |
| Thermal Resistance | | θ_{JA} | 150 | | $^{\circ}C/W$ |

NOTES: (1) 1000-hour life test at $150^{\circ}C$ demonstrated randomly distributed variation in the range of measurement limits—approximately $10\mu V$. (2) See Applications Information section, and Figures 1 and 3. (3) Does not include error and TCR of external gain-setting resistors. (4) Dynamic response is limited by filtering. Higher bandwidths can be achieved by adjusting the filter. (5) See Typical Characteristics, "Input Offset Voltage vs Warm-Up Time".

TYPICAL CHARACTERISTICS

At $T_A = 25^\circ\text{C}$, $V_S = +5\text{V}$, Gain = 100, and $R_L = 10\text{k}\Omega$ with external equivalent filter corner of 1kHz, unless otherwise noted.

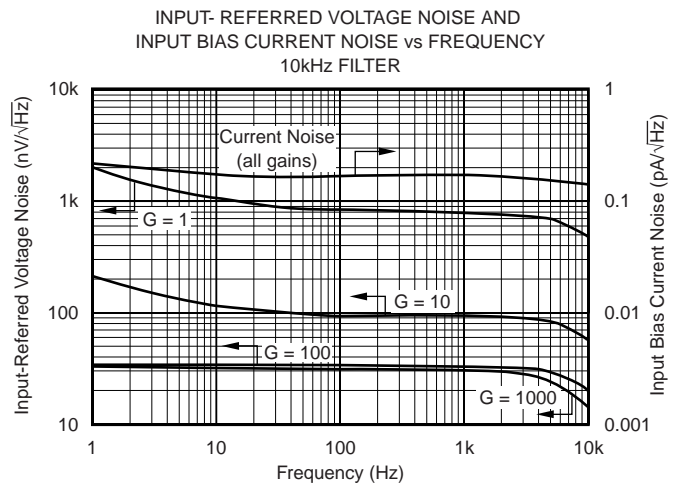
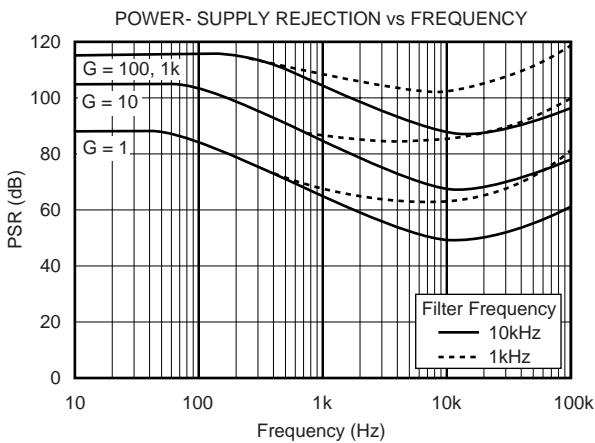
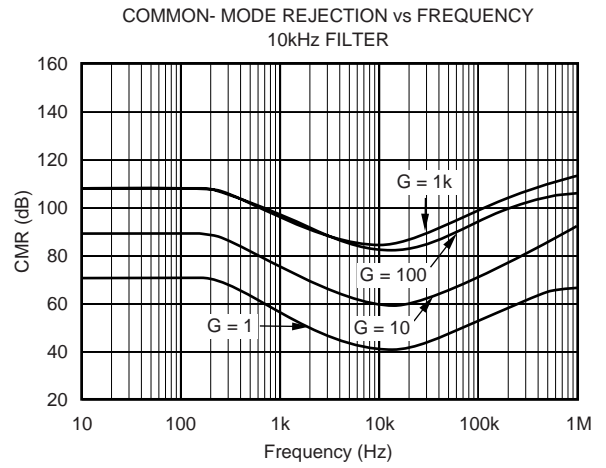
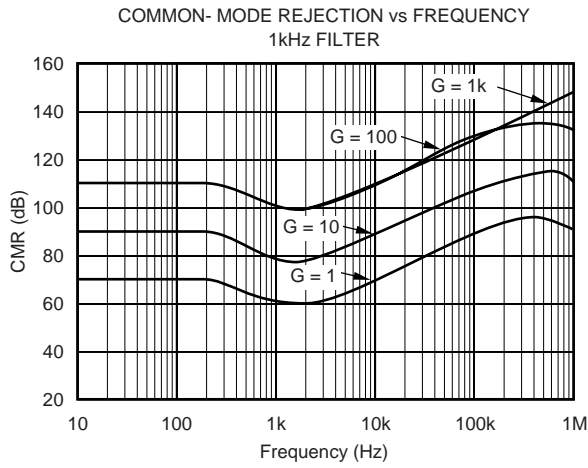
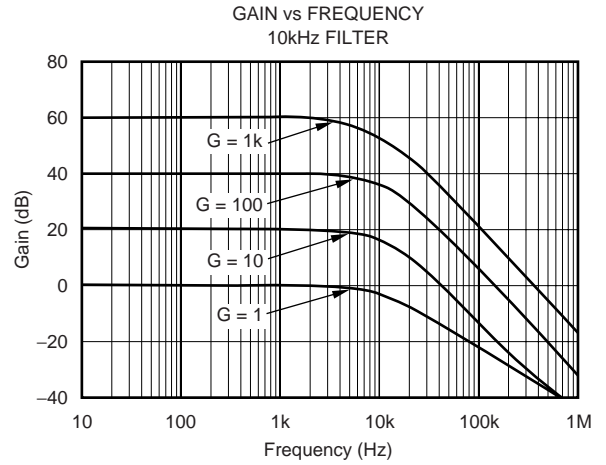
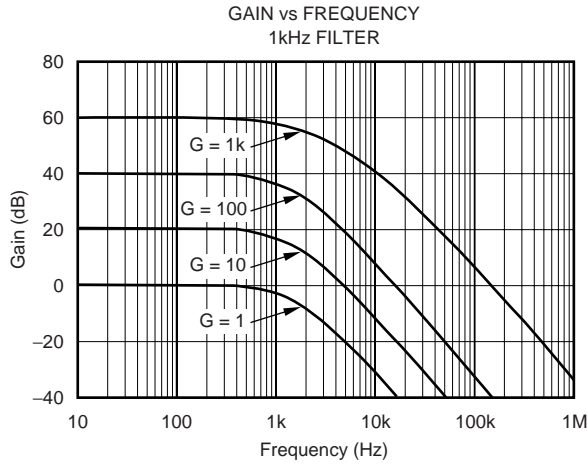

TYPICAL CHARACTERISTICS (Cont.)

At $T_A = 25^\circ\text{C}$, $V_S = +5\text{V}$, Gain = 100, and $R_L = 10\text{k}\Omega$ with external equivalent filter corner of 1kHz, unless otherwise noted.

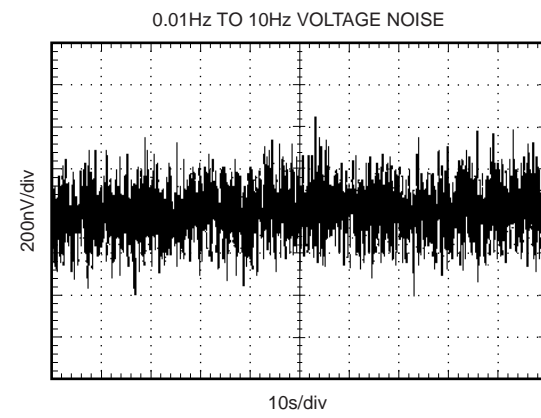
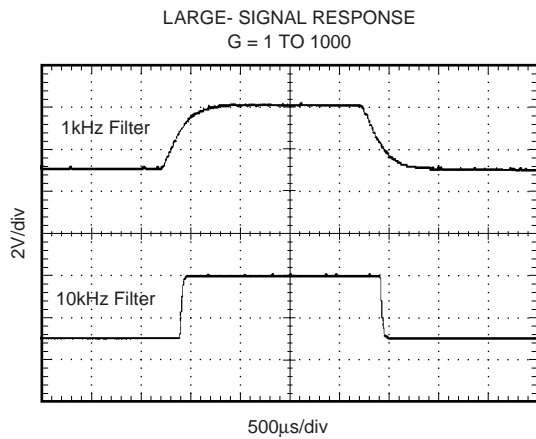
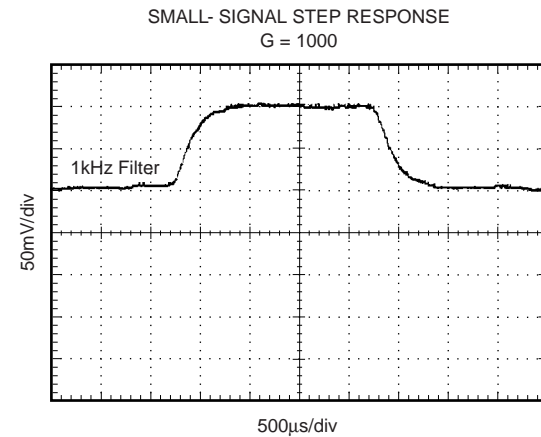
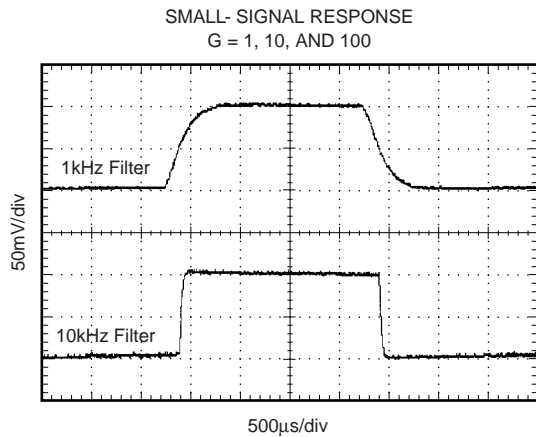
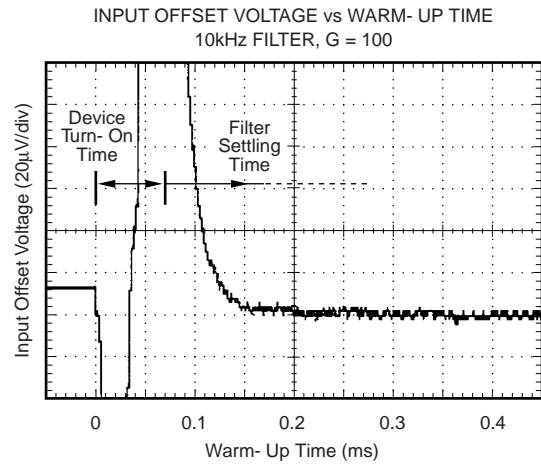
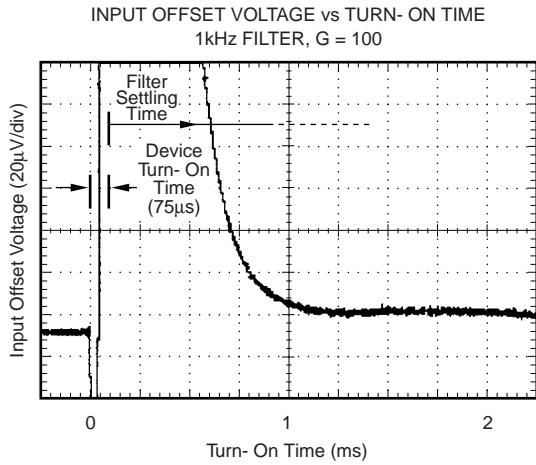

TYPICAL CHARACTERISTICS (Cont.)

At $T_A = 25^\circ\text{C}$, $V_S = +5\text{V}$, Gain = 100, and $R_L = 10\text{k}\Omega$ with external equivalent filter corner of 1kHz, unless otherwise noted.

OFFSET VOLTAGE DRIFT PRODUCTION DISTRIBUTION
G = 1

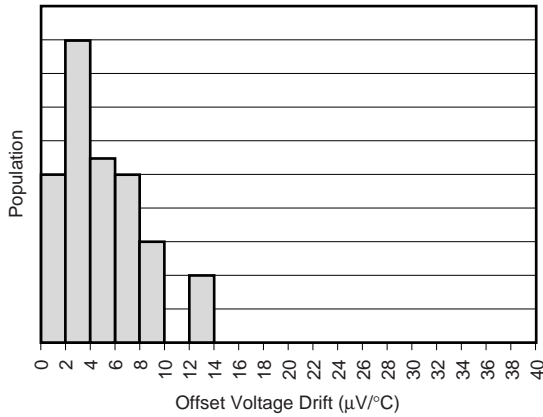

OFFSET VOLTAGE PRODUCTION DISTRIBUTION
G = 1

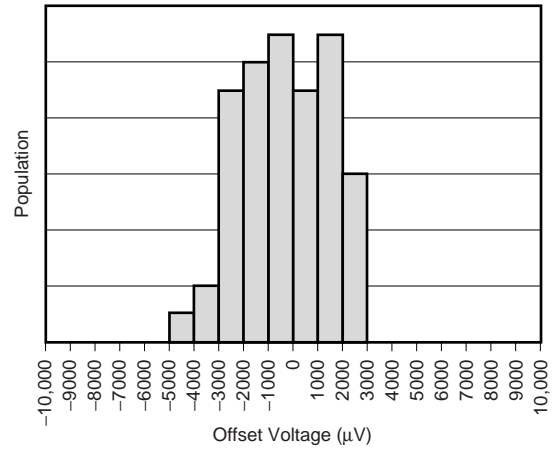

OFFSET VOLTAGE DRIFT PRODUCTION DISTRIBUTION
G = 10

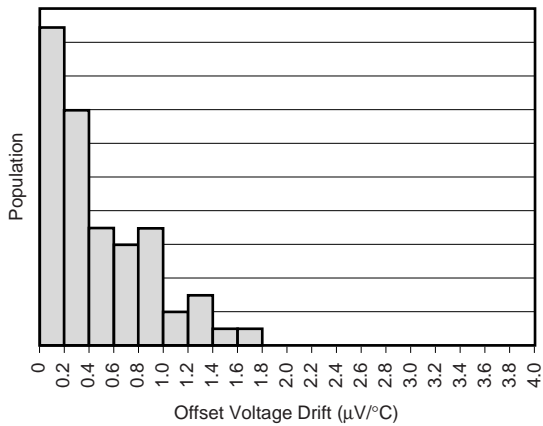

OFFSET VOLTAGE PRODUCTION DISTRIBUTION
G = 10

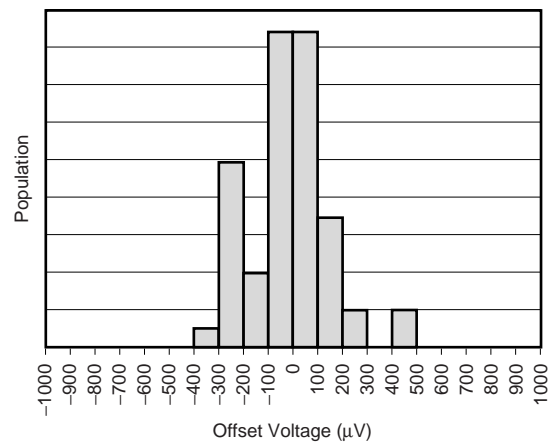

OFFSET VOLTAGE DRIFT PRODUCTION DISTRIBUTION
G = 100, 1000

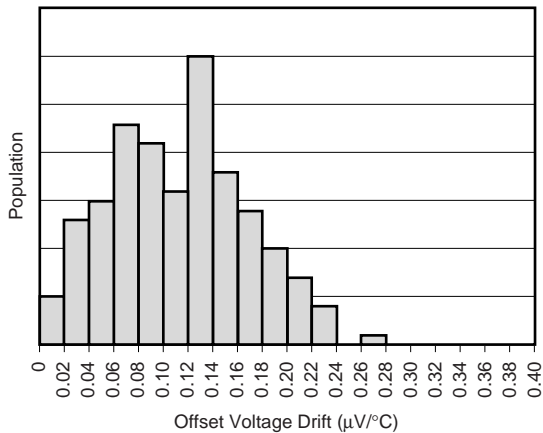

OFFSET VOLTAGE PRODUCTION DISTRIBUTION
G = 100, 1000

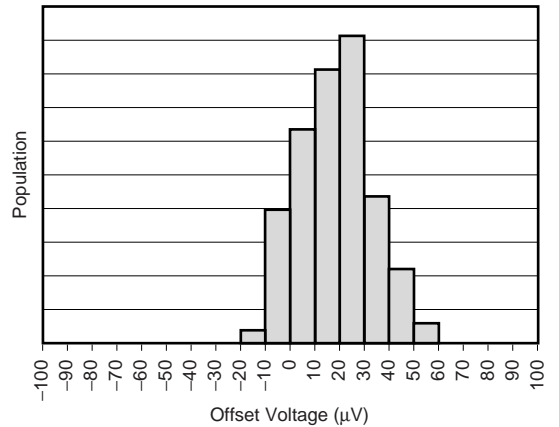

TYPICAL CHARACTERISTICS (Cont.)

At $T_A = 25^\circ\text{C}$, $V_S = +5\text{V}$, Gain = 100, and $R_L = 10\text{k}\Omega$ with external equivalent filter corner of 1kHz, unless otherwise noted.

GAIN ERROR PRODUCTION DISTRIBUTION
G = 100

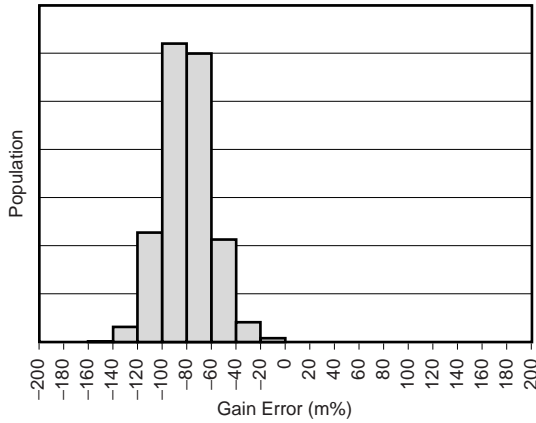

INPUT- REFERRED RIPPLE SPECTRUM
G = 100

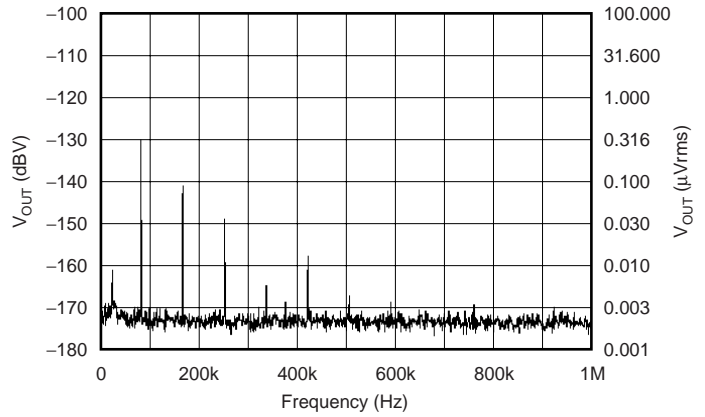

QUIESCENT CURRENT vs TEMPERATURE

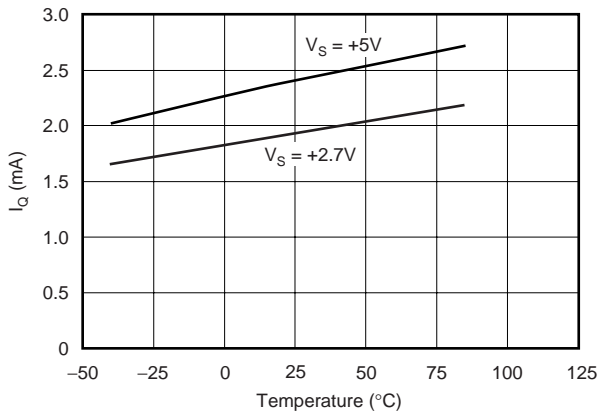

INPUT BIAS CURRENT vs TEMPERATURE

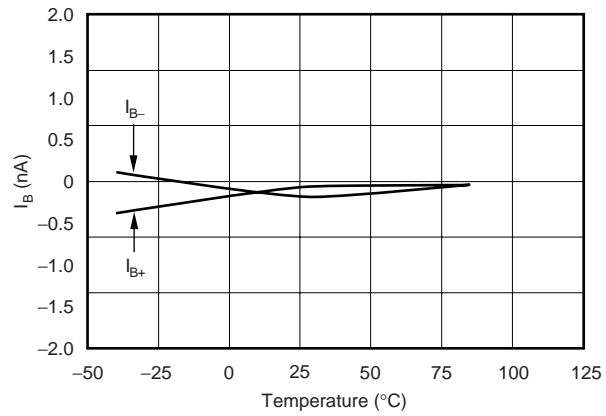

APPLICATIONS INFORMATION

Figure 1 shows the basic connections required for operation of the INA326. A 0.1µF capacitor, placed close to and across the power-supply pins is strongly recommended for highest accuracy. $R_O C_O$ is an output filter that minimizes auto-correction circuitry noise. This output filter may also serve as an anti-aliasing filter ahead of an Analog-to-Digital (A/D) converter. It is also optional based on desired precision.

The output reference terminal is taken at the low side of R_2 (I_{A_COMMON}).

The INA326 uses a unique internal topology to achieve excellent Common-Mode Rejection (CMR). Unlike conventional instrumentation amplifiers, CMR is not affected by resistance in the reference connections or sockets. See "Inside the INA326" for further detail. To achieve best high-frequency CMR, minimize capacitance on pins 1 and 8.

SETTING THE GAIN

The INA326 is a 2-stage amplifier with each stage gain set by R_1 and R_2 , respectively (see Figure 5, "Inside the INA326", for details). Overall gain is described by the equation:

$$G = 2 \frac{R_2}{R_1} \quad (1)$$

The stability and temperature drift of the external gain-setting resistors will affect gain by an amount that can be directly inferred from the gain equation (1).

Resistor values for commonly used gains are shown in Figure 1. Gain-set resistor values for best performance are different for +5V single-supply and for ±2.5V dual-supply operation. Optimum value for R_1 can be calculated by:

$$R_1 = V_{IN_MAX} / 12.5\mu A \quad (2)$$

where R_1 must be no less than 2kΩ.

| DESIRED GAIN | R_1 (Ω) | $R_2 \parallel C_2$ (Ω nF) |
|--------------|-----------|-------------------------------|
| 0.1 | 400k | 20k 5 |
| 0.2 | 400k | 40k 2.5 |
| 0.5 | 400k | 100k 1 |
| 1 | 200k | 100k 1 |
| 2 | 100k | 100k 1 |
| 5 | 40k | 100k 1 |
| 10 | 20k | 100k 1 |
| 20 | 10k | 100k 1 |
| 50 | 4k | 100k 1 |
| 100 | 2k | 100k 1 |
| 200 | 2k | 200k 0.5 |
| 500 | 2k | 500k 0.2 |
| 1000 | 2k | 1M 0.1 |
| 2000 | 2k | 2M 0.05 |
| 5000 | 2k | 5M 0.02 |
| 10000 | 2k | 10M 0.01 |

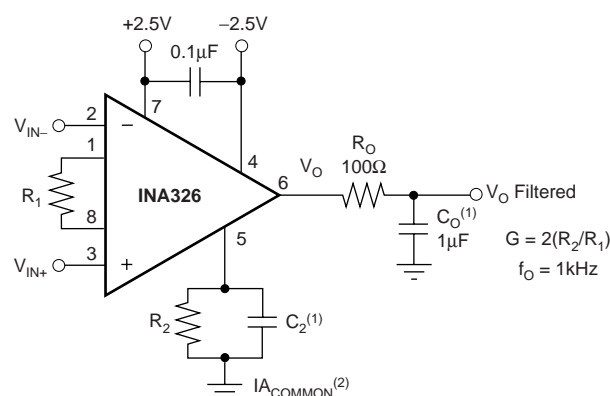

- (1) C_2 and C_O combine to form a 2-pole response that is -3dB at 1kHz. Each individual pole is at 1.5kHz.
 (2) Output voltage is referenced to I_{A_COMMON} (see text).

| DESIRED GAIN | R_1 (Ω) | $R_2 \parallel C_2$ (Ω nF) |
|--------------|-----------|-------------------------------|
| 0.1 | 400k | 20k 5 |
| 0.2 | 400k | 40k 2.5 |
| 0.5 | 400k | 100k 1 |
| 1 | 400k | 200k 0.5 |
| 2 | 200k | 200k 0.5 |
| 5 | 80k | 200k 0.5 |
| 10 | 40k | 200k 0.5 |
| 20 | 20k | 200k 0.5 |
| 50 | 8k | 200k 0.5 |
| 100 | 4k | 200k 0.5 |
| 200 | 2k | 200k 0.5 |
| 500 | 2k | 500k 0.2 |
| 1000 | 2k | 1M 0.1 |
| 2000 | 2k | 2M 0.05 |
| 5000 | 2k | 5M 0.02 |
| 10000 | 2k | 10M 0.01 |

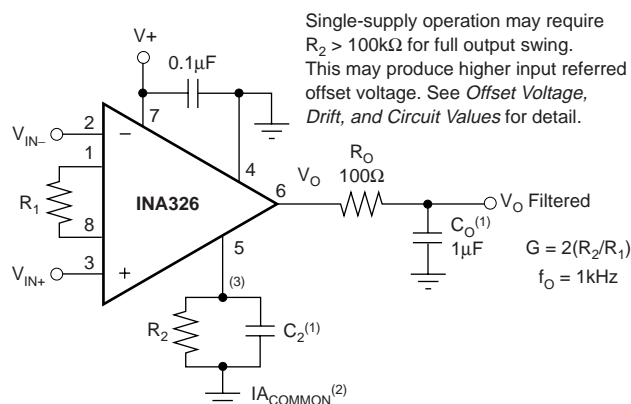

- Single-supply operation may require $R_2 > 100k\Omega$ for full output swing. This may produce higher input referred offset voltage. See *Offset Voltage, Drift, and Circuit Values* for detail.
 (1) C_2 and C_O combine to form a 2-pole response that is -3dB at 1kHz. Each individual pole is at 1.5kHz.
 (2) Output voltage is referenced to I_{A_COMMON} (see text).
 (3) Output offset voltage required for measurement near zero (see Figure 28).

NOTES: (1) C_2 and C_O combine to form a 2-pole response that is -3dB at 1kHz. Each individual pole is at 1.5kHz. (2) Output voltage is referenced to I_{A_COMMON} (see text). (3) Output offset voltage required for measurement near zero (see Figure 6).

FIGURE 1. Basic Connections. NOTE: Connections for INA327 differ—see Pin Configuration for detail.

Following this design procedure for R_1 produces the maximum possible input stage gain for best accuracy and lowest noise. Circuit layout and supply bypassing can affect performance. Minimize the stray capacitance on pins 1 and 8. Use recommended supply bypassing, including a capacitor directly from pin 7 to pin 4 (V_+ to V_-), even with dual (split) power supplies (see Figure 1).

OFFSET VOLTAGE, DRIFT, AND CIRCUIT VALUES

As with other multi-stage instrumentation amplifiers, input-referred offset voltage depends on gain and circuit values. The specified offset and drift performance is rated at $R_1 = 2k\Omega$, $R_2 = 100k\Omega$, and $V_S = \pm 2.5V$. Offset voltage and drift for other circuit values can be estimated from the following equations:

$$V_{OS} = 10\mu V + (50nA)(R_2)/G \quad (3)$$

$$dV_{OS}/dT = 0.12\mu V/^\circ C + (0.16nA/^\circ C)(R_2)/G \quad (4)$$

These equations might imply that offset and drift can be minimized by making the value of R_2 much lower than the values indicated in Figure 1. These values, however, have been chosen to assure that the output current into R_2 is kept less than or equal to $\pm 25\mu A$, while maintaining R_1 's value greater than or equal to $2k\Omega$. Some applications with limited output voltage swing or low power-supply voltage may allow lower values for R_2 , thus providing lower input-referred offset voltage and offset voltage drift.

Conversely, single-supply operation with R_2 grounded requires that R_2 values be made larger to assure that current remains under $25\mu A$. This will increase the input-referred offset voltage and offset voltage drift.

Circuit conditions that cause more than $25\mu A$ to flow in R_2 will not cause damage, but may produce more nonlinearity.

INA327 ENABLE FUNCTION

The INA327 adds an enable/shutdown function to the INA326. Its pinout differs from the INA326—see the Pin Configuration for detail.

The INA327 can be enabled by applying a logic HIGH voltage level to the Enable pin. Conversely, a logic LOW voltage level will disable the amplifier, reducing its supply current from $2.4mA$ to typically $2\mu A$. For battery-operated applications, this feature may be used to greatly reduce the average current and extend battery life. This pin should be connected to a valid high or low voltage or driven, not left open circuit. The Enable pin can be modeled as a CMOS input gate as in Figure 2.

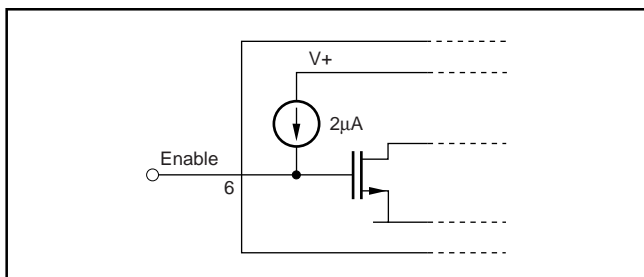

FIGURE 2. Enable Pin Model.

The enable time following shutdown is $75\mu s$ plus the settling time due to filters (see Typical Characteristics, "Input Offset Voltage vs Warm-up Time"). Disable time is $100\mu s$. This allows the INA327 to be operated as a "gated" amplifier, or to have its output multiplexed onto a common output bus. When disabled, the output assumes a high-impedance state.

INA327 PIN 5

Pin 5 of the INA327 should be connected to V_+ to ensure proper operation.

DYNAMIC PERFORMANCE

The typical characteristic "Gain vs Frequency" shows that the INA326 has nearly constant bandwidth regardless of gain. This results from the bandwidth limiting from the recommended filters.

NOISE PERFORMANCE

Internal auto-correction circuitry eliminates virtually all $1/f$ noise (noise that increases at low frequency) in gains of 100 or greater. Noise performance is affected by gain-setting resistor values. Follow recommendations in the "Setting Gain" section for best performance.

Total noise is a combination of input stage noise and output stage noise. When referred to the input, the total mid-band noise is:

$$V_N = 33nV/\sqrt{Hz} + \frac{800nV/\sqrt{Hz}}{G} \quad (5)$$

The output noise has some $1/f$ components that affect performance in gains less than 10. See typical characteristic "Input-Referred Voltage Noise vs Frequency."

High-frequency noise is created by internal auto-correction circuitry and is highly dependent on the filter characteristics chosen. This may be the dominant source of noise visible when viewing the output on an oscilloscope. Low cutoff frequency filters will provide lowest noise. Figure 3 shows the typical noise performance as a function of cutoff frequency.

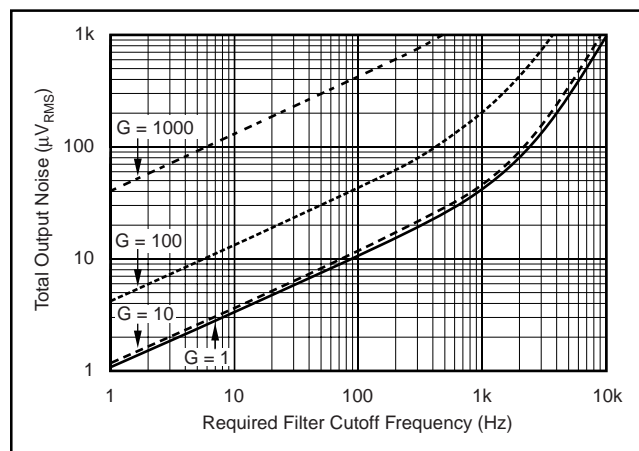

FIGURE 3. Total Output Noise vs Required Filter Cutoff Frequency.

Applications sensitive to the spectral characteristics of high-frequency noise may require consideration of the spurious frequencies generated by internal clocking circuitry. “Spurs” occur at approximately 90kHz and its harmonics (see typical characteristic “Input-Referred Ripple Spectrum”) which may be reduced by additional filtering below 1kHz.

Insufficient filtering at pin 5 can cause nonlinearity with large output voltage swings (very near the supply rails). Noise must be sufficiently filtered at pin 5 so that noise peaks do not “hit the rail” and change the average value of the signal. Figure 3 shows guidelines for filter cutoff frequency.

HIGH-FREQUENCY NOISE

C_2 and C_O form filters to reduce internally generated auto-correction circuitry noise. Filter frequencies can be chosen to optimize the trade-off between noise and frequency response of the application, as shown in Figure 3. The cutoff frequencies of the filters are generally set to the same frequency. Figure 3 shows the typical output noise for four gains as a function of the -3dB cutoff frequency of each filter response. Small signals may exhibit the addition of internally generated auto-correction circuitry noise at the output. This noise, combined with broadband noise, becomes most evident in higher gains with filters of wider bandwidth.

INPUT BIAS CURRENT RETURN PATH

The input impedance of the INA326 is extremely high—approximately $10^{10}\Omega$. However, a path must be provided for the input bias current of both inputs. This input bias current is approximately $\pm 0.2\text{nA}$. High input impedance means that this input bias current changes very little with varying input voltage.

Input circuitry must provide a path for this input bias current for proper operation. Figure 4 shows provision for an input bias current path in a thermocouple application. Without a bias current path, the inputs will float to an undefined potential and the output voltage may not be valid.

INPUT COMMON-MODE RANGE

Common instrumentation amplifiers do not respond linearly with common-mode signals near the power-supply rails, even if “rail-to-rail” op amps are used. The INA326 uses a unique topology to achieve true rail-to-rail input behavior (see Figure 5, “Inside the INA326”). The linear input voltage range of each input terminal extends to 20mV below the negative rail, and 100mV above the positive rail.

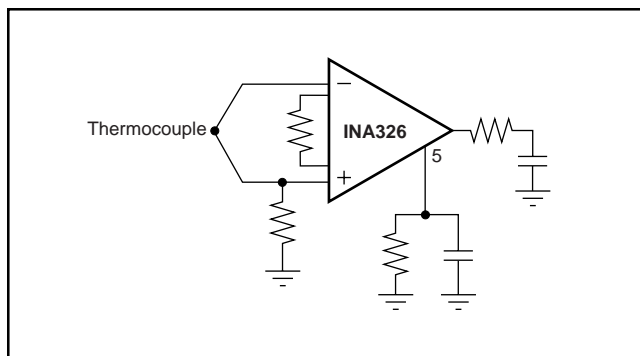

FIGURE 4. Providing Input Bias Current Return Path.

INPUT PROTECTION

The inputs of the INA326 are protected with internal diodes connected to the power-supply rails. These diodes will clamp the applied signal to prevent it from damaging the input circuitry. If the input signal voltage can exceed the power supplies by more than 0.5V, the input signal current should be limited to less than 10mA to protect the internal clamp diodes. This can generally be done with a series input resistor. Some signal sources are inherently current-limited and do not require limiting resistors.

FILTERING

Filtering can be adjusted through selection of R_2C_2 and R_OC_O for the desired trade-off of noise and bandwidth. Adjustment of these components will result in more or less ripple due to auto-correction circuitry noise and will also affect broadband noise. Filtering limits slew rate, settling time, and output overload recovery time.

It is generally desirable to keep the resistance of R_O relatively low to avoid DC gain error created by the subsequent stage loading. This may result in relatively high values for C_O to produce the desired filter response. The impedance of R_OC_O can be scaled higher to produce smaller capacitor values if the load impedance is very high.

Certain capacitor types greater than $0.1\mu\text{F}$ may have dielectric absorption effects that can significantly increase settling time in high-accuracy applications (settling to 0.01%). Polypropylene, polystyrene, and polycarbonate types are generally good. Certain “high-K” ceramic types may produce slow settling “tails.” Settling time to 0.1% is not generally affected by high-K ceramic capacitors. Electrolytic types are not recommended for C_2 and C_O .

INSIDE THE INA326

The INA326 uses a new, unique internal circuit topology that provides true rail-to-rail input. Unlike other instrumentation amplifiers, it can linearly process inputs up to 20mV below the negative power-supply rail, and 100mV above the positive power-supply rail. Conventional instrumentation amplifier circuits cannot deliver such performance, even if rail-to-rail op amps are used.

The ability to reject common-mode signals is derived in most instrumentation amplifiers through a combination of amplifier CMR and accurately matched resistor ratios. The INA326 converts the input voltage to a current. Current-mode signal processing provides rejection of common-mode input voltage and power-supply variation without accurately matched resistors.

A simplified diagram shows the basic circuit function. The differential input voltage, $(V_{IN+}) - (V_{IN-})$ is applied across R_1 . The signal-generated current through R_1 comes from

A1 and A2's output stages. A2 combines the current in R_1 with a mirrored replica of the current from A1. The resulting current in A2's output and associated current mirror is two times the current in R_1 . This current flows in (or out) of pin 5 into R_2 . The resulting gain equation is:

$$G = 2 \frac{R_2}{R_1}$$

Amplifiers A1, A2, and their associated mirrors are powered from internal charge-pumps that provide voltage supplies that are beyond the positive and negative supply rails. As a result, the voltage developed on R_2 can actually swing 20mV *below* the negative power-supply rail, and 100mV *above* the positive supply rail. A3 provides a buffered output of the voltage on R_2 . A3's input stage is also operated from the charge-pumped power supplies for true rail-to-rail operation.

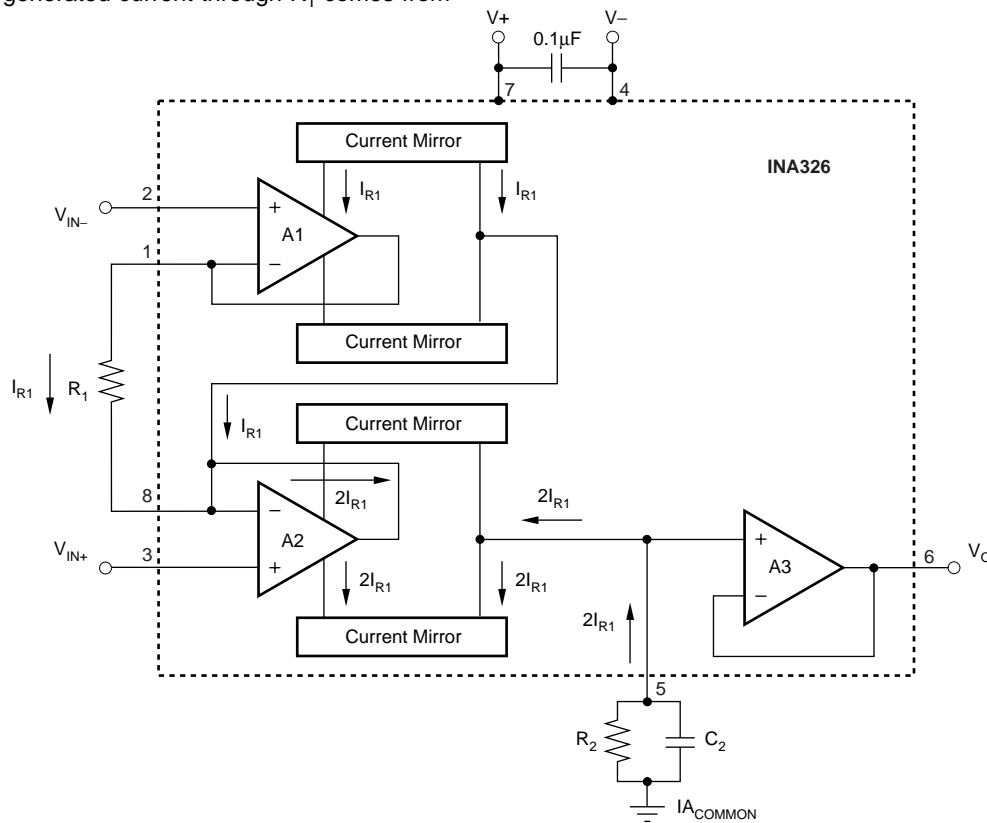

FIGURE 5. Simplified Circuit Diagram.

APPLICATION CIRCUITS

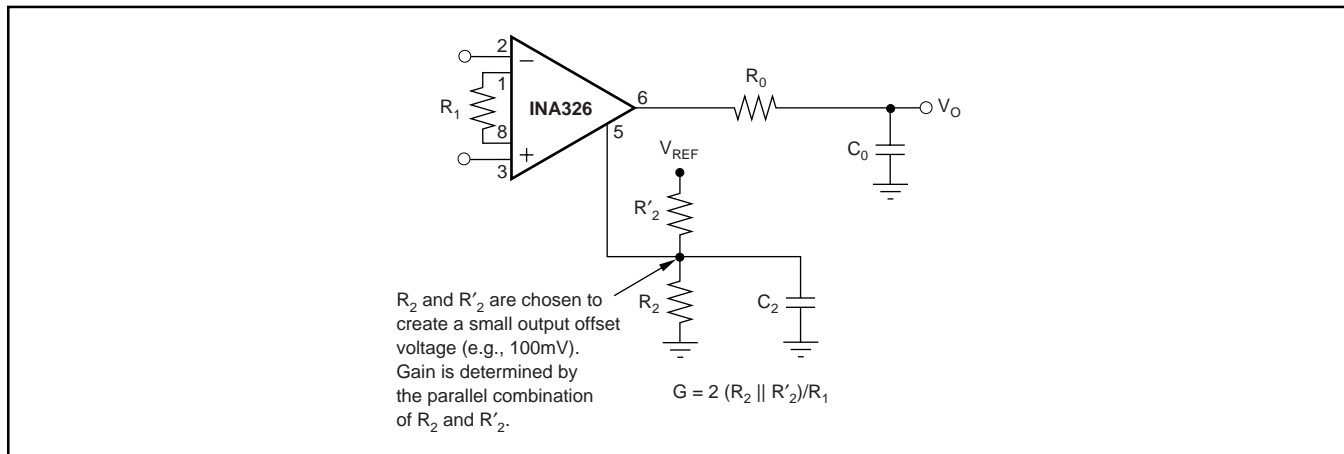

FIGURE 6. Generating Output Offset Voltage.

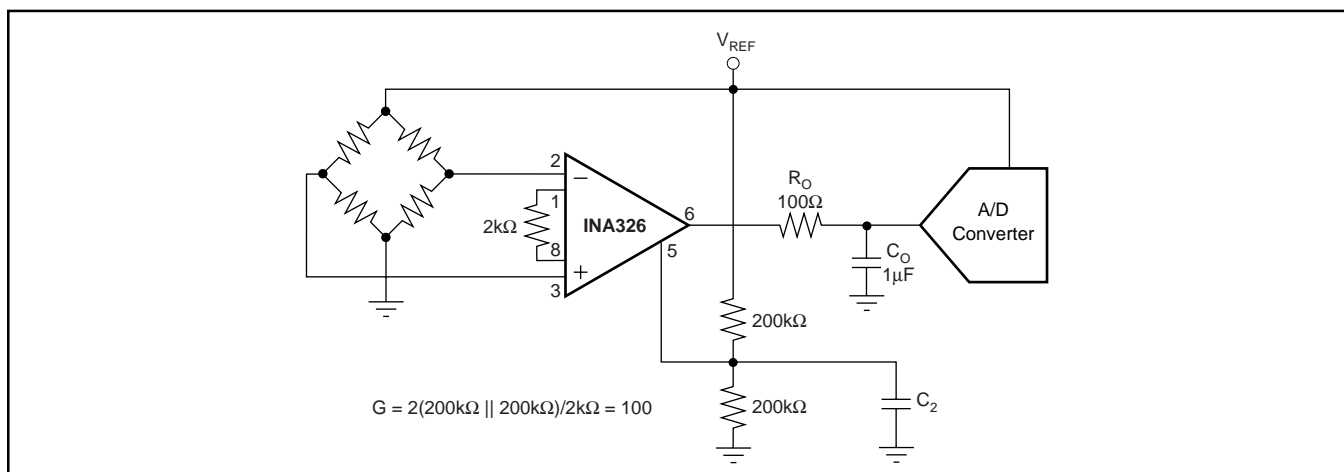

FIGURE 7. Output Referenced to $V_{REF}/2$.

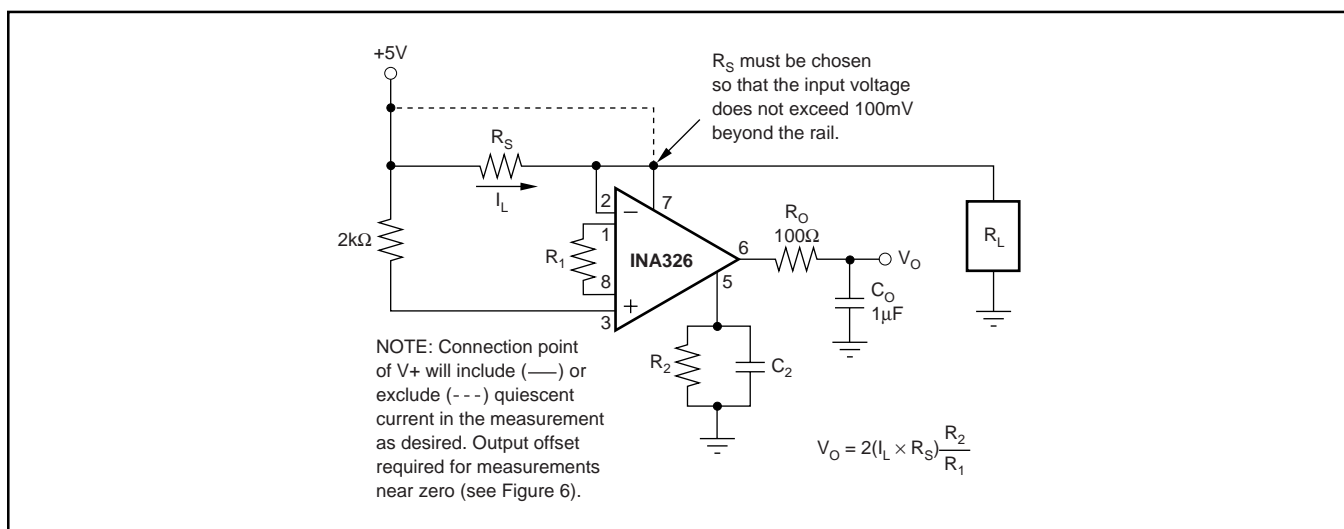

FIGURE 8. High-Side Current Shunt Measurement.

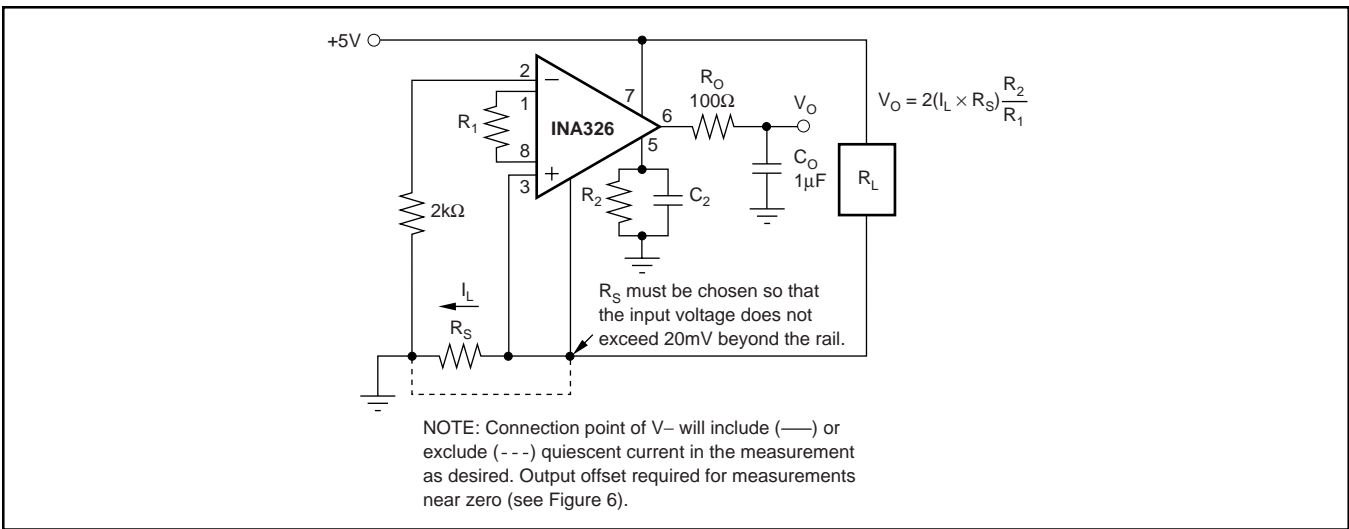

FIGURE 9. Low-Side Current Shunt Measurement.

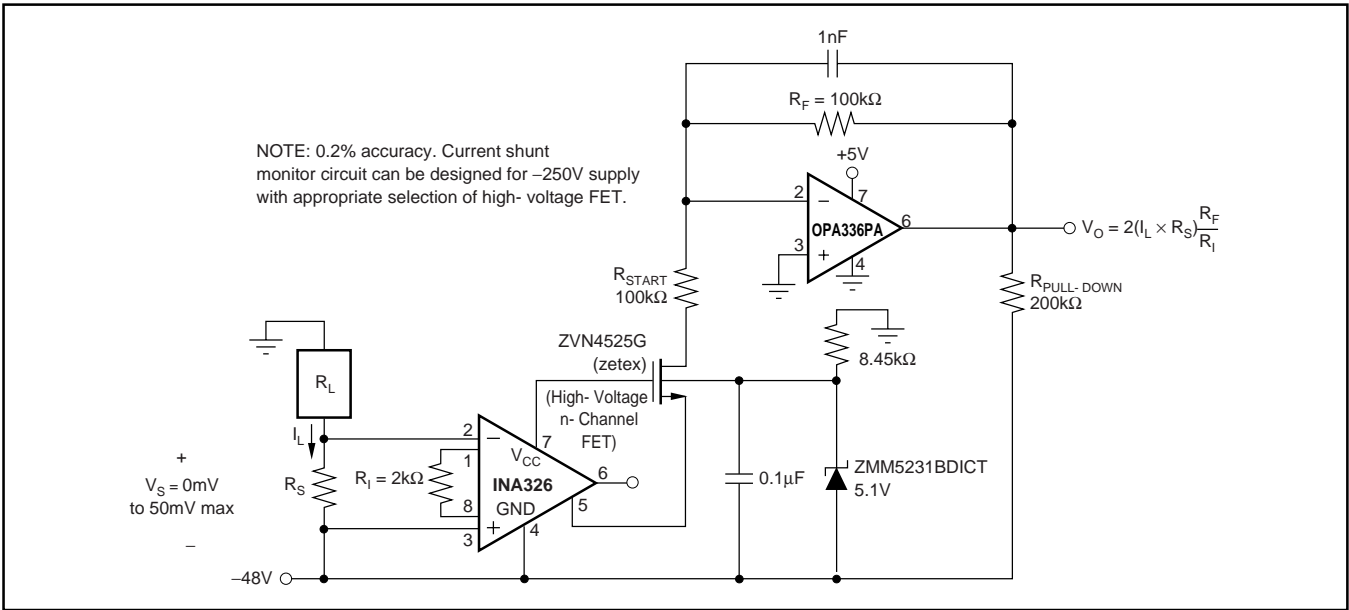

FIGURE 10. Low-Side -48V Current Shunt Monitor.

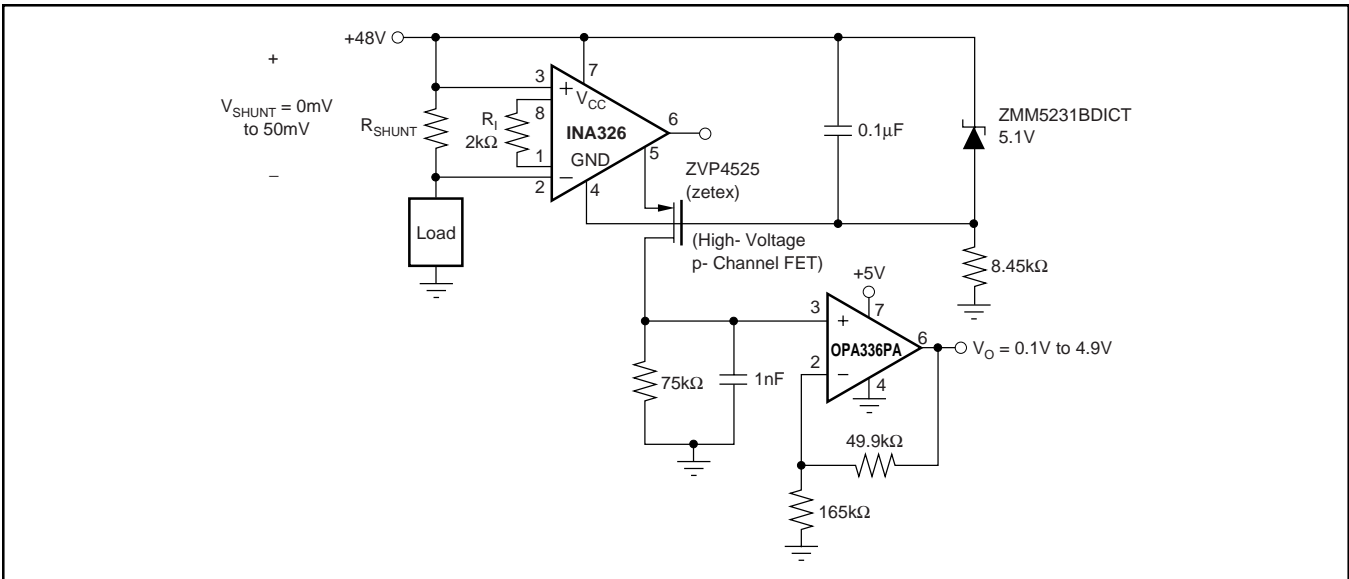

FIGURE 11. High-Side +48V Current Shunt Monitor.

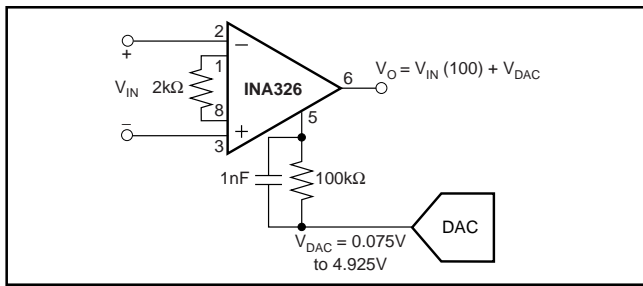
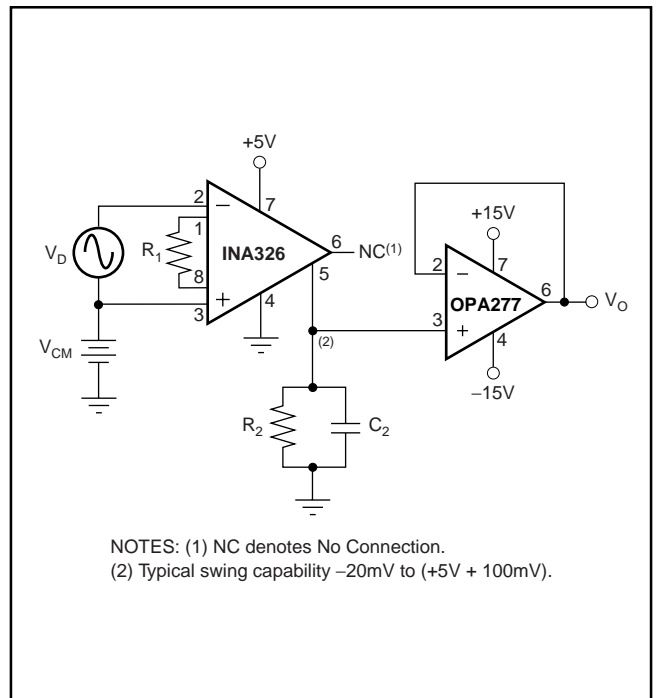
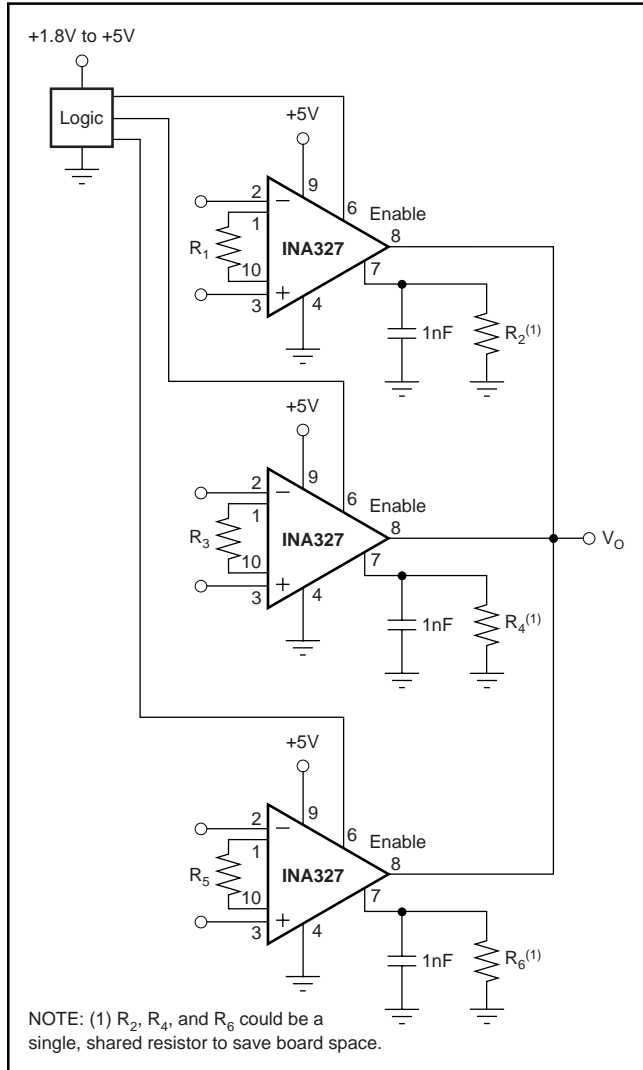

FIGURE 12. Output Offset Adjustment.



NOTES: (1) NC denotes No Connection.
 (2) Typical swing capability -20mV to $(+5\text{V} + 100\text{mV})$.

FIGURE 14. Output from Pin 5 to Allow Swing Beyond the Rail.



NOTE: (1) R_2 , R_4 , and R_6 could be a single, shared resistor to save board space.

FIGURE 13. Multiplexed Output.

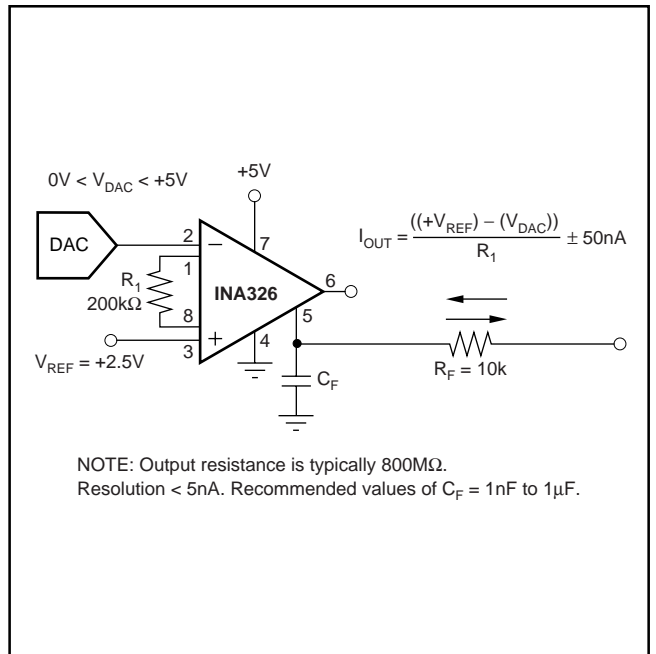

NOTE: Output resistance is typically $800\text{M}\Omega$.
 Resolution $< 5\text{nA}$. Recommended values of $C_F = 1\text{nF}$ to $1\mu\text{F}$.

FIGURE 15. Programmable $\pm 25\mu\text{A}$ Current Source with High Output Resistance.

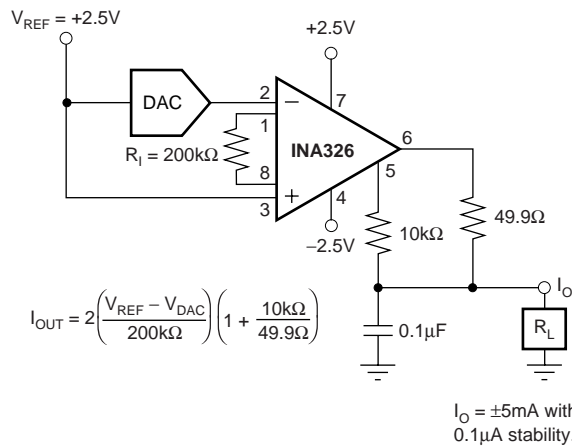
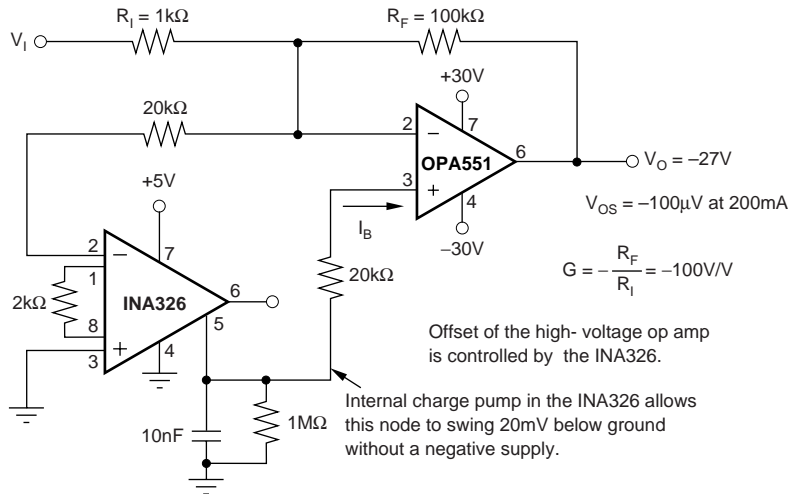

FIGURE 16. Programmable ±5mA Current Source.



NOTES: (1) The OPA551 is a 60V op amp. (2) The INA326 does not require a negative supply to correct for negative V_{OS} values from the high-voltage op amp. (3) Voltage offset contribution of I_B (OPA551) is $100pA \cdot 2k\Omega = 0.2\mu V$.

FIGURE 17. ±27V Output at 200mA Amplifier with 100μV Offset.

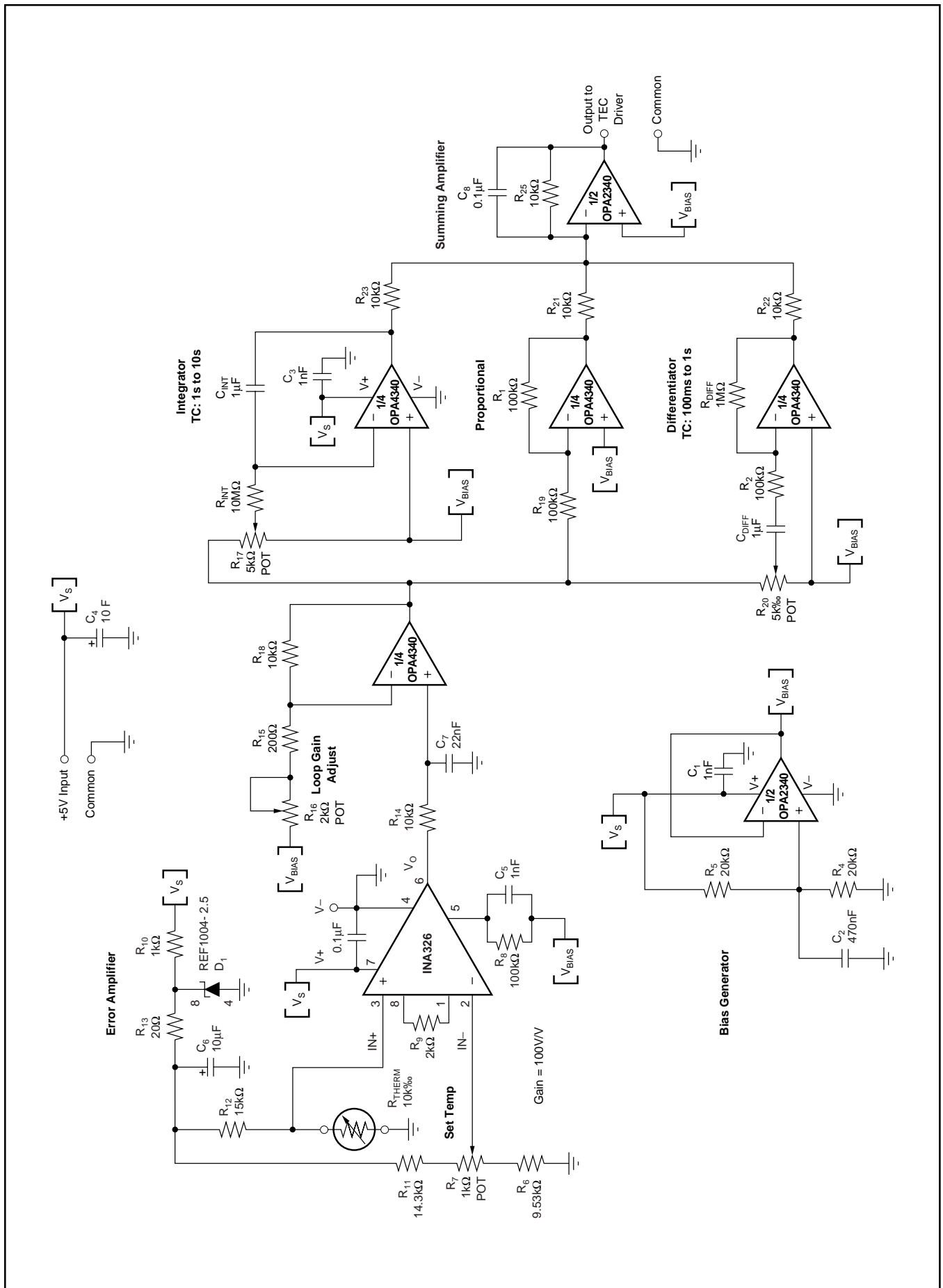

FIGURE 18. Single-Supply PID Temperature Control Loop.

PACKAGING INFORMATION

| Orderable Device | Status (1) | Package Type | Package Drawing | Pins | Package Qty | Eco Plan (2) | Lead finish/ Ball material (6) | MSL Peak Temp (3) | Op Temp (°C) | Device Marking (4/5) | Samples |
|------------------|---------------|--------------|-----------------|------|-------------|-----------------|--------------------------------------|----------------------|--------------|-------------------------|-------------------------|
| INA326EA/250 | ACTIVE | VSSOP | DGK | 8 | 250 | RoHS & Green | NIPDAUAG SN | Level-2-260C-1 YEAR | -40 to 85 | B26 | Samples |
| INA326EA/250G4 | ACTIVE | VSSOP | DGK | 8 | 250 | RoHS & Green | NIPDAUAG | Level-2-260C-1 YEAR | -40 to 85 | B26 | Samples |
| INA326EA/2K5 | ACTIVE | VSSOP | DGK | 8 | 2500 | RoHS & Green | NIPDAUAG SN | Level-2-260C-1 YEAR | -40 to 85 | B26 | Samples |
| INA327EA/250 | ACTIVE | VSSOP | DGS | 10 | 250 | RoHS & Green | Call TI NIPDAUAG | Level-2-260C-1 YEAR | -40 to 85 | B27 | Samples |
| INA327EA/250G4 | ACTIVE | VSSOP | DGS | 10 | 250 | RoHS & Green | Call TI | Level-2-260C-1 YEAR | -40 to 85 | B27 | Samples |
| INA327EA/2K5 | ACTIVE | VSSOP | DGS | 10 | 2500 | RoHS & Green | Call TI NIPDAUAG | Level-2-260C-1 YEAR | -40 to 85 | B27 | Samples |

(1) The marketing status values are defined as follows:

ACTIVE: Product device recommended for new designs.

LIFEBUY: TI has announced that the device will be discontinued, and a lifetime-buy period is in effect.

NRND: Not recommended for new designs. Device is in production to support existing customers, but TI does not recommend using this part in a new design.

PREVIEW: Device has been announced but is not in production. Samples may or may not be available.

OBSELETE: TI has discontinued the production of the device.

(2) **RoHS:** TI defines "RoHS" to mean semiconductor products that are compliant with the current EU RoHS requirements for all 10 RoHS substances, including the requirement that RoHS substance do not exceed 0.1% by weight in homogeneous materials. Where designed to be soldered at high temperatures, "RoHS" products are suitable for use in specified lead-free processes. TI may reference these types of products as "Pb-Free".

RoHS Exempt: TI defines "RoHS Exempt" to mean products that contain lead but are compliant with EU RoHS pursuant to a specific EU RoHS exemption.

Green: TI defines "Green" to mean the content of Chlorine (Cl) and Bromine (Br) based flame retardants meet JS709B low halogen requirements of <=1000ppm threshold. Antimony trioxide based flame retardants must also meet the <=1000ppm threshold requirement.

(3) MSL, Peak Temp. - The Moisture Sensitivity Level rating according to the JEDEC industry standard classifications, and peak solder temperature.

(4) There may be additional marking, which relates to the logo, the lot trace code information, or the environmental category on the device.

(5) Multiple Device Markings will be inside parentheses. Only one Device Marking contained in parentheses and separated by a "-" will appear on a device. If a line is indented then it is a continuation of the previous line and the two combined represent the entire Device Marking for that device.

(6) Lead finish/Ball material - Orderable Devices may have multiple material finish options. Finish options are separated by a vertical ruled line. Lead finish/Ball material values may wrap to two lines if the finish value exceeds the maximum column width.

Important Information and Disclaimer: The information provided on this page represents TI's knowledge and belief as of the date that it is provided. TI bases its knowledge and belief on information provided by third parties, and makes no representation or warranty as to the accuracy of such information. Efforts are underway to better integrate information from third parties. TI has taken and continues to take reasonable steps to provide representative and accurate information but may not have conducted destructive testing or chemical analysis on incoming materials and chemicals. TI and TI suppliers consider certain information to be proprietary, and thus CAS numbers and other limited information may not be available for release.

In no event shall TI's liability arising out of such information exceed the total purchase price of the TI part(s) at issue in this document sold by TI to Customer on an annual basis.

TAPE AND REEL INFORMATION

QUADRANT ASSIGNMENTS FOR PIN 1 ORIENTATION IN TAPE

*All dimensions are nominal

| Device | Package Type | Package Drawing | Pins | SPQ | Reel Diameter (mm) | Reel Width W1 (mm) | A0 (mm) | B0 (mm) | K0 (mm) | P1 (mm) | W (mm) | Pin1 Quadrant |
|--------------|--------------|-----------------|------|------|--------------------|--------------------|---------|---------|---------|---------|--------|---------------|
| INA326EA/250 | VSSOP | DGK | 8 | 250 | 330.0 | 12.4 | 5.3 | 3.4 | 1.4 | 8.0 | 12.0 | Q1 |
| INA326EA/2K5 | VSSOP | DGK | 8 | 2500 | 330.0 | 12.4 | 5.3 | 3.4 | 1.4 | 8.0 | 12.0 | Q1 |

TAPE AND REEL BOX DIMENSIONS



*All dimensions are nominal

| Device | Package Type | Package Drawing | Pins | SPQ | Length (mm) | Width (mm) | Height (mm) |
|--------------|--------------|-----------------|------|------|-------------|------------|-------------|
| INA326EA/250 | VSSOP | DGK | 8 | 250 | 366.0 | 364.0 | 50.0 |
| INA326EA/2K5 | VSSOP | DGK | 8 | 2500 | 366.0 | 364.0 | 50.0 |

DGK0008A



PACKAGE OUTLINE

VSSOP - 1.1 mm max height

SMALL OUTLINE PACKAGE



4214862/A 04/2023

NOTES:

PowerPAD is a trademark of Texas Instruments.

1. All linear dimensions are in millimeters. Any dimensions in parenthesis are for reference only. Dimensioning and tolerancing per ASME Y14.5M.
2. This drawing is subject to change without notice.
3. This dimension does not include mold flash, protrusions, or gate burrs. Mold flash, protrusions, or gate burrs shall not exceed 0.15 mm per side.
4. This dimension does not include interlead flash. Interlead flash shall not exceed 0.25 mm per side.
5. Reference JEDEC registration MO-187.

EXAMPLE BOARD LAYOUT

DGK0008A

™ VSSOP - 1.1 mm max height

SMALL OUTLINE PACKAGE



LAND PATTERN EXAMPLE
EXPOSED METAL SHOWN
SCALE: 15X

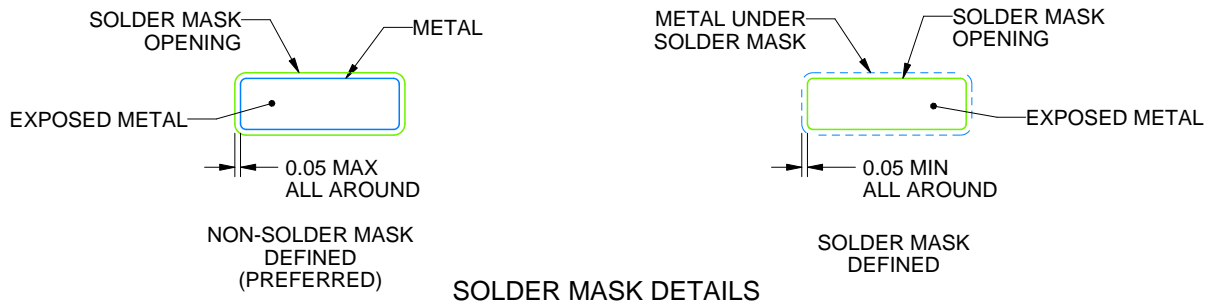

4214862/A 04/2023

NOTES: (continued)

6. Publication IPC-7351 may have alternate designs.
7. Solder mask tolerances between and around signal pads can vary based on board fabrication site.
8. Vias are optional depending on application, refer to device data sheet. If any vias are implemented, refer to their locations shown on this view. It is recommended that vias under paste be filled, plugged or tented.
9. Size of metal pad may vary due to creepage requirement.

EXAMPLE STENCIL DESIGN

DGK0008A

TM VSSOP - 1.1 mm max height

SMALL OUTLINE PACKAGE



SOLDER PASTE EXAMPLE
SCALE: 15X

4214862/A 04/2023

NOTES: (continued)

11. Laser cutting apertures with trapezoidal walls and rounded corners may offer better paste release. IPC-7525 may have alternate design recommendations.
12. Board assembly site may have different recommendations for stencil design.

DGS0010A



PACKAGE OUTLINE

VSSOP - 1.1 mm max height

SMALL OUTLINE PACKAGE



NOTES:

1. All linear dimensions are in millimeters. Any dimensions in parenthesis are for reference only. Dimensioning and tolerancing per ASME Y14.5M.
2. This drawing is subject to change without notice.
3. This dimension does not include mold flash, protrusions, or gate burrs. Mold flash, protrusions, or gate burrs shall not exceed 0.15 mm per side.
4. This dimension does not include interlead flash. Interlead flash shall not exceed 0.25 mm per side.
5. Reference JEDEC registration MO-187, variation BA.

EXAMPLE BOARD LAYOUT

DGS0010A

VSSOP - 1.1 mm max height

SMALL OUTLINE PACKAGE



LAND PATTERN EXAMPLE
SCALE:10X



SOLDER MASK DETAILS
NOT TO SCALE

4221984/A 05/2015

NOTES: (continued)

- 6. Publication IPC-7351 may have alternate designs.
- 7. Solder mask tolerances between and around signal pads can vary based on board fabrication site.

EXAMPLE STENCIL DESIGN

DGS0010A

VSSOP - 1.1 mm max height

SMALL OUTLINE PACKAGE



SOLDER PASTE EXAMPLE
BASED ON 0.125 mm THICK STENCIL
SCALE:10X

4221984/A 05/2015

NOTES: (continued)

8. Laser cutting apertures with trapezoidal walls and rounded corners may offer better paste release. IPC-7525 may have alternate design recommendations.
9. Board assembly site may have different recommendations for stencil design.

IMPORTANT NOTICE AND DISCLAIMER

TI PROVIDES TECHNICAL AND RELIABILITY DATA (INCLUDING DATA SHEETS), DESIGN RESOURCES (INCLUDING REFERENCE DESIGNS), APPLICATION OR OTHER DESIGN ADVICE, WEB TOOLS, SAFETY INFORMATION, AND OTHER RESOURCES "AS IS" AND WITH ALL FAULTS, AND DISCLAIMS ALL WARRANTIES, EXPRESS AND IMPLIED, INCLUDING WITHOUT LIMITATION ANY IMPLIED WARRANTIES OF MERCHANTABILITY, FITNESS FOR A PARTICULAR PURPOSE OR NON-INFRINGEMENT OF THIRD PARTY INTELLECTUAL PROPERTY RIGHTS.

These resources are intended for skilled developers designing with TI products. You are solely responsible for (1) selecting the appropriate TI products for your application, (2) designing, validating and testing your application, and (3) ensuring your application meets applicable standards, and any other safety, security, regulatory or other requirements.

These resources are subject to change without notice. TI grants you permission to use these resources only for development of an application that uses the TI products described in the resource. Other reproduction and display of these resources is prohibited. No license is granted to any other TI intellectual property right or to any third party intellectual property right. TI disclaims responsibility for, and you will fully indemnify TI and its representatives against, any claims, damages, costs, losses, and liabilities arising out of your use of these resources.

TI's products are provided subject to [TI's Terms of Sale](#) or other applicable terms available either on [ti.com](https://www.ti.com) or provided in conjunction with such TI products. TI's provision of these resources does not expand or otherwise alter TI's applicable warranties or warranty disclaimers for TI products.

TI objects to and rejects any additional or different terms you may have proposed.

Mailing Address: Texas Instruments, Post Office Box 655303, Dallas, Texas 75265
Copyright © 2024, Texas Instruments Incorporated