

LM5033 100-V Push-Pull Voltage Mode PWM Controller

1 Features

- Internal High-Voltage (100 V) Start-Up Regulator
- Single Resistor Oscillator Setting
- Synchronizable
- Precision Reference Output
- Adjustable Soft Start
- Overcurrent Protection
- Direct Optocoupler Interface
- 1.5-A Peak Gate Drivers
- Thermal Shutdown

2 Applications

- Intermediate DC-DC Bus Converter
- Telecommunication Power Converters
- Industrial Power Converters
- 42-V Automotive Systems

3 Description

The LM5033 high-voltage PWM controller contains all the features necessary to implement push-pull, half-bridge, and full-bridge topologies. Applications include closed-loop voltage mode converters with a highly regulated output voltage, or open-loop *DC transformers* such as an Intermediate bus converter (IBC) with an efficiency greater than 95%. Two alternating gate driver outputs with a specified deadtime are provided.

The LM5033 includes a start-up regulator that operates over a wide input range from 15 V to 100 V. Additional features include: precision voltage reference output, current limit detection, remote shutdown, soft start, sync capability, and thermal shutdown. This high-speed IC has total propagation delays less than 100 ns and a 1-MHz capable oscillator.

Device Information⁽¹⁾

PART NUMBER	PACKAGE	BODY SIZE (NOM)
LM5033	VSSOP (10)	3.00 mm x 3.00 mm
	WSON (10)	4.00 mm x 4.00 mm

(1) For all available packages, see the orderable addendum at the end of the data sheet.

Typical Application Circuit

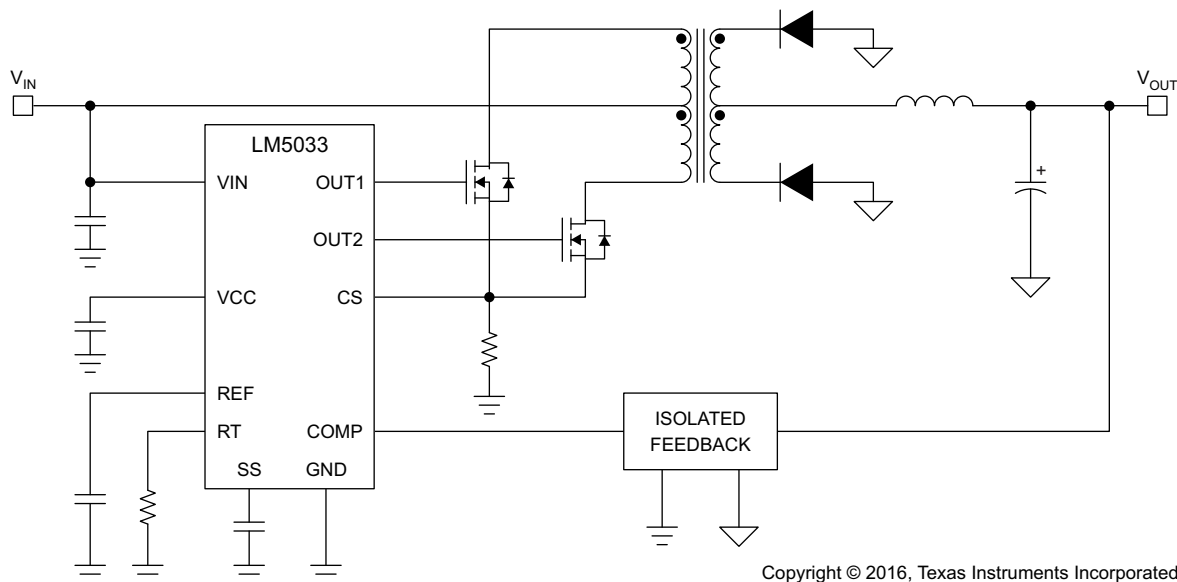

Copyright © 2016, Texas Instruments Incorporated



Table of Contents

1 Features 1 2 Applications 1 3 Description 1 4 Revision History 2 5 Pin Configuration and Functions 3 6 Specifications 4 6.1 Absolute Maximum Ratings 4 6.2 ESD Ratings 4 6.3 Recommended Operating Conditions 4 6.4 Thermal Information 4 6.5 Electrical Characteristics 5 6.6 Typical Characteristics 6 7 Detailed Description 8 7.1 Overview 8 7.2 Functional Block Diagram 8 7.3 Feature Description 9	7.4 Device Functional Modes 11 8 Application and Implementation 12 8.1 Application Information 12 8.2 Typical Application 12 9 Power Supply Recommendations 15 10 Layout 15 10.1 Layout Guidelines 15 10.2 Layout Example 16 11 Device and Documentation Support 17 11.1 Documentation Support 17 11.2 Receiving Notification of Documentation Updates 17 11.3 Community Resources 17 11.4 Trademarks 17 11.5 Electrostatic Discharge Caution 17 11.6 Glossary 17 12 Mechanical, Packaging, and Orderable Information 17
---	--

4 Revision History

NOTE: Page numbers for previous revisions may differ from page numbers in the current version.

Changes from Revision B (April 2013) to Revision C	Page
• Added <i>Device Information</i> table, <i>Pin Configuration and Functions</i> section, <i>Specifications</i> section, <i>ESD Ratings</i> table, <i>Thermal Information</i> table, <i>Detailed Description</i> section, <i>Application and Implementation</i> section, <i>Power Supply Recommendations</i> section, <i>Layout</i> section, <i>Device and Documentation Support</i> section, and <i>Mechanical, Packaging, and Orderable Information</i> section	1
• Deleted <i>Ordering Information Table</i> ; see POA at the end of the datasheet	1
• Changed values in the <i>Thermal Information</i> table to align with JEDEC standards	4

Changes from Revision A (May 2005) to Revision B	Page
• Changed layout of National Semiconductor Data Sheet to TI format	1

5 Pin Configuration and Functions

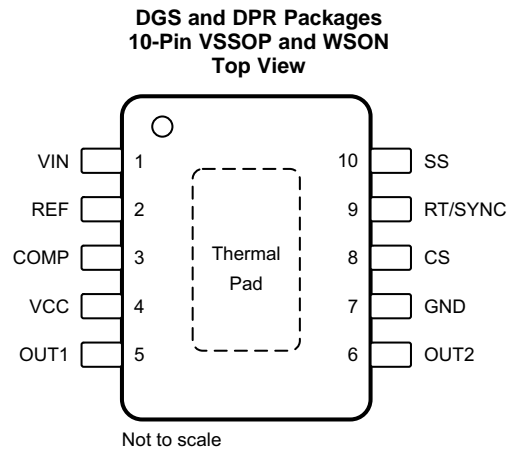

Pin Functions

PIN		I/O	DESCRIPTION
NAME	NO.		
COMP	3	I	Feedback to the inverting input of the PWM comparator, through a 3:1 divider. The output duty cycle increases as the voltage to this pin increases. Internally there is a 5-k Ω pullup resistor to 5.2 V.
CS	8	I	Current sense input for the current limit detection. If voltage to this pin exceeds 0.5 V the outputs are disabled and the soft-start (SS) pin is discharged to ground.
GND	7	—	Connections to external ground must be done with care for optimum performance. See Feature Description and Application and Implementation for more information.
OUT1	5	O	Alternating output gate driver, which can source and sink 1.5 A.
OUT2	6	O	Alternating output gate driver, which can source and sink 1.5 A.
REF	2	O	Sink only, requires an external pullup resistor. This can be used as a 2.5-V precision output reference for external circuitry.
RT/SYNC	9	I	Oscillator timing resistor pin and synchronization input. An external resistor to ground sets the oscillator frequency. This pin also accepts AC-coupled synchronization pulses from an external source.
SS	10	I	Soft-start pin. An internal 10- μ A current source and an external capacitor set the soft-start timing. This pin can be externally pulled to below 0.5 V to disable the output drivers.
VCC	4	I/O	9.6-V output from the internal high voltage series pass regulator. An external voltage, 10 V to 15 V, can be applied to this pin to shutdown the internal regulator, reducing internal dissipation. An internal diode connects VCC to VIN.
VIN	1	I	Input to the start-up regulator. Input range from 15 V to 90 V, with transient capability to 100 V.
Exposed Pad ⁽¹⁾	—	—	The exposed die attach pad on the WSON package must be connected to a PCB thermal pad at ground potential. See AN-1187 Leadless Leadframe Package (LLP) (SNOA401).

(1) Only available on the WSON package.

6 Specifications

6.1 Absolute Maximum Ratings

 see ⁽¹⁾

	MIN	MAX	UNIT
V _{IN} to GND	-0.3	100	V
V _{CC} to GND	-0.3	16	V
RT/SYNC to GND	-0.3	5.5	V
COMP, CS, and SS to GND	-0.3	7	V
Power dissipation ⁽²⁾	Internally Limited		
Maximum junction temperature, T _{J(MAX)}		150	°C
Storage temperature, T _{stg}	-65	150	°C

- (1) Stresses beyond those listed under *Absolute Maximum Ratings* may cause permanent damage to the device. These are stress ratings only, which do not imply functional operation of the device at these or any other conditions beyond those indicated under *Recommended Operating Conditions*. Exposure to absolute-maximum-rated conditions for extended periods may affect device reliability.
- (2) The maximum allowable power dissipation is a function of the maximum allowed junction temperature (T_{J(max)}), the ambient temperature (T_A), and the junction-to-ambient thermal resistance (θ_{JA}). The maximum allowable power dissipation can be calculated from PD = (T_{J(max)} - T_A) / θ_{JA}. Excessive power dissipation causes the thermal shutdown to activate.

6.2 ESD Ratings

	VALUE	UNIT
V _(ESD) Electrostatic discharge Human-body model (HBM), per ANSI/ESDA/JEDEC JS-001 ⁽¹⁾	±2000	V

- (1) JEDEC document JEP155 states that 500-V HBM allows safe manufacturing with a standard ESD control process.

6.3 Recommended Operating Conditions

over operating free-air temperature range (unless otherwise noted)

	MIN	MAX	UNIT
V _{IN} Input voltage	15	99	V
T _J Operating junction temperature	-40	125	°C

6.4 Thermal Information

THERMAL METRIC ⁽¹⁾	LM5033		UNIT
	DGS (VSSOP)	DPR (WSON)	
	10 PINS	10 PINS	
R _{θJA} Junction-to-ambient thermal resistance	158	38.1	°C/W
R _{θJC(top)} Junction-to-case (top) thermal resistance	52.2	36.7	°C/W
R _{θJB} Junction-to-board thermal resistance	78.1	15.2	°C/W
ψ _{JT} Junction-to-top characterization parameter	4.8	0.3	°C/W
ψ _{JB} Junction-to-board characterization parameter	76.8	15.5	°C/W
R _{θJC(bot)} Junction-to-case (bottom) thermal resistance	—	4.7	°C/W

- (1) For more information about traditional and new thermal metrics, see the *Semiconductor and IC Package Thermal Metrics* application report.

6.5 Electrical Characteristics

$V_{IN} = 48\text{ V}$, $V_{CC} = 10\text{ V}$ (applied externally), and $R_T = 26.7\text{ k}\Omega$, Typical limits are given for $T_J = 25^\circ\text{C}$, Minimum and Maximum limits apply over $T_J = -40^\circ\text{C}$ to 125°C (unless otherwise noted).⁽¹⁾⁽²⁾

PARAMETER		TEST CONDITIONS	MIN	TYP	MAX	UNIT
VCC STARTUP REGULATOR						
V_{CCReg}	VCC voltage	VCC is open	9.2	9.6	10	V
$I_{CC(OUT)}$	VCC current limit	OUT1 and OUT2 disabled, extended supply to VCC disconnected	20	34		mA
I_{IN}	Startup regulator current into VIN	Normal operation, $V_{IN} = 90\text{ V}$		150	500	μA
		Extended VCC supply disconnected, output load = 1800 pF		7		mA
		$V_{SS} = 0\text{ V}$		3		mA
UVT	VCC undervoltage threshold (increasing V_{CC})		$V_{CCReg} - 300\text{ mV}$	$V_{CCReg} - 100\text{ mV}$		V
	UVT hysteresis (decreasing V_{CC})		2.3	2.8	3.3	
$I_{CC(IN)}$	Supply current from external source to VCC	$V_{SS} = 0\text{ V}$		2	3	mA
		SS is open, output load = 1800 pF		7		
2.5-V REFERENCE						
V_{REF}	Output voltage	REF sink current = 5 mA	2.44	2.5	2.56	V
	Current sink capability		5	13		mA
CURRENT SENSE						
CS	Threshold voltage		0.45	0.5	0.55	V
	CS delay to output	V_{CS} taken from zero to 0.6 V, time for V_{OUT1} or V_{OUT2} to fall to 90% of V_{CC} , $C_{LOAD} = 0$ at OUT1 and OUT2		30		ns
	Current sink capability (clocked)	$V_{CS} \leq 0.3\text{ V}$	3	6		mA
SOFT START						
	Soft-start current source		7	10	13	μA
	Soft-start to COMP offset		0.25	0.5	0.75	V
	Open circuit voltage			5		V
OSCILLATOR						
F_{S1}	Internal frequency	$R_T = 26.7\text{ k}\Omega$	175	200	225	kHz
F_{S2}	Internal frequency	$R_T = 8.2\text{ k}\Omega$		600		kHz
V_{SYNC}	Sync threshold			3.2	3.8	V
	RT/SYNC DC voltage			2		V
PWM COMPARATOR INPUT						
t_{PWM}	Gain from COMP to PWM comparator			0.34		V/V
	Maximum duty cycle at OUT1 and OUT2	See PWM Comparator		$100 \times (0.5 t_s - t_D) / t_s$		%
	Minimum duty cycle at OUT1 and OUT2	$V_{COMP} = 0\text{ V}$			0%	
	Open circuit voltage		4.2	5.2	6.2	V
	Short circuit current	$V_{COMP} = 0\text{ V}$	0.6	1.1	1.5	mA
OUTPUT DRIVERS						
t_D	Deadtime	$C_{LOAD} = 0$ at OUT1 and OUT2, time measured from 10% of falling output to 10% of rising output	85	135	185	ns
	Rise time	$C_{LOAD} = 1\text{ nF}$		16		ns
	Fall time	$C_{LOAD} = 1\text{ nF}$		16		ns
	Output high voltage	$I_{OUT} = 50\text{ mA}$ (source)	$V_{CC} - 0.75$	$V_{CC} - 0.25$		V
	Output low voltage	$I_{OUT} = 100\text{ mA}$ (sink)		0.25	0.75	V
	Maximum source current			1.5		A
	Maximum sink current			1.5		A
THERMAL SHUTDOWN						
t_{SD}	Shutdown temperature			165		$^\circ\text{C}$
	Shutdown temperature hysteresis			15		$^\circ\text{C}$

(1) Minimum and maximum limits are 100% production tested at 25°C . Limits over the operating temperature range are specified through correlation using Statistical Quality Control (SQC) methods. Limits are used to calculate TI's Average Outgoing Quality Level (AOQL).

(2) Typical specifications represent the most likely parametric norm at 25°C operation.

6.6 Typical Characteristics

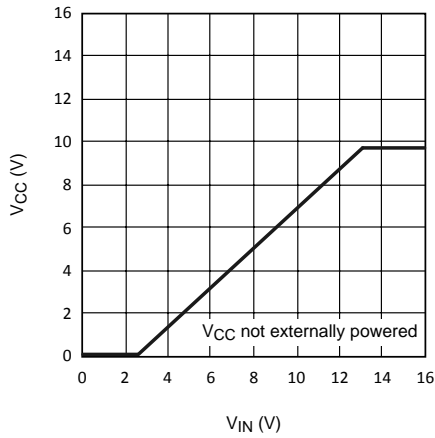

Figure 1. V_{CC} vs V_{IN}

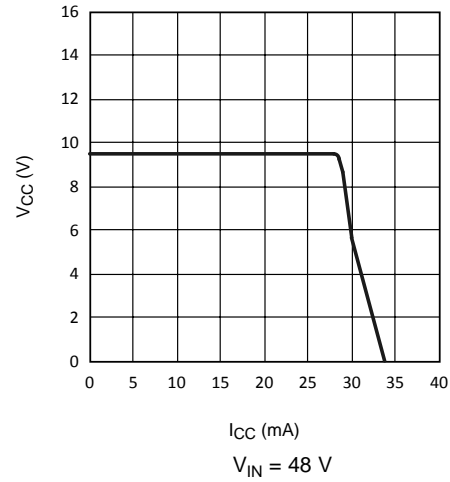

Figure 2. V_{CC} vs I_{CC}

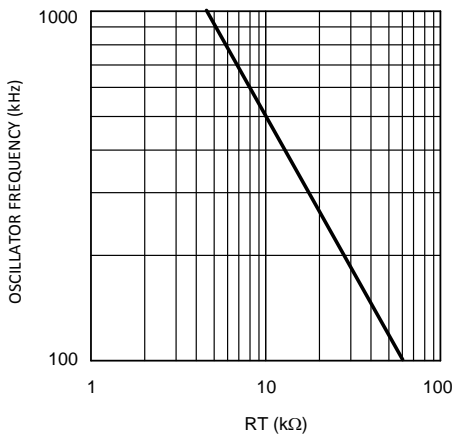

Figure 3. Oscillator Frequency vs R_T

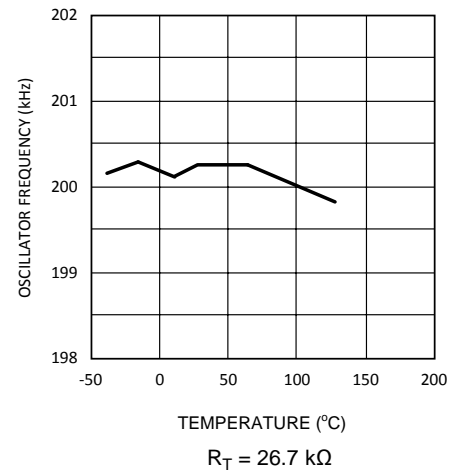

Figure 4. Oscillator Frequency vs Temperature

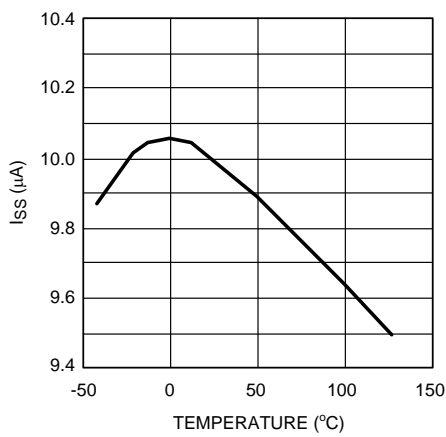

Figure 5. Soft-Start Current vs Temperature

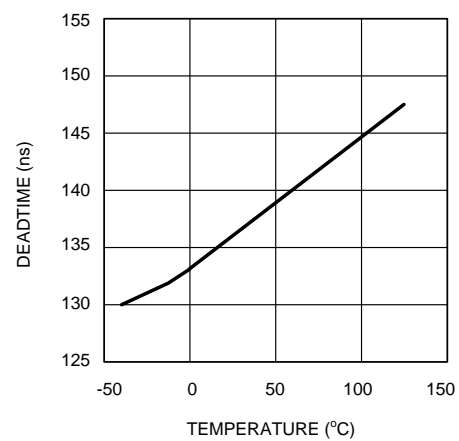

Figure 6. Dead Time vs Temperature

Typical Characteristics (continued)

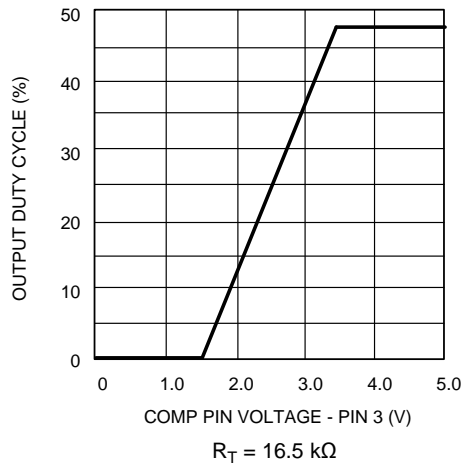

Figure 7. Output Duty Cycle vs COMP Voltage

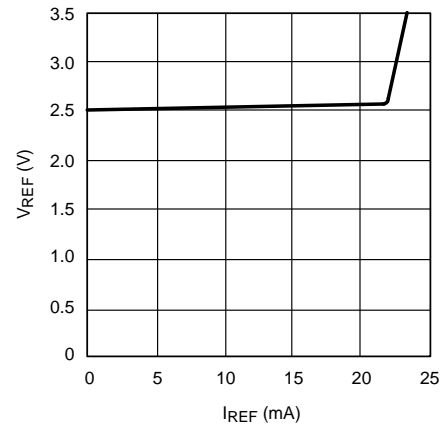

Figure 8. V_REF vs I_REF

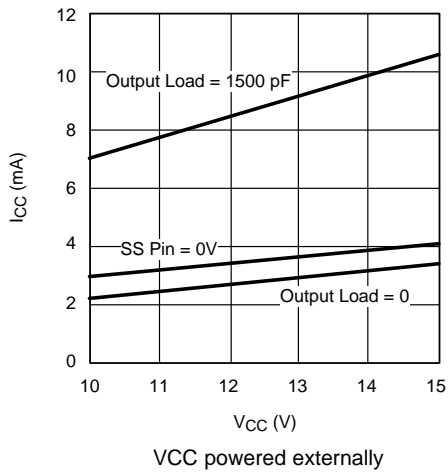

Figure 9. I_{CC} vs V_{CC}

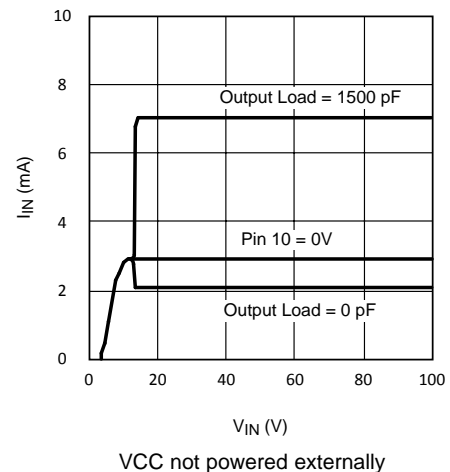

Figure 10. I_{IN} vs V_{IN}

7 Detailed Description

7.1 Overview

The LM5033 high-voltage PWM controller contains all of the features necessary to implement push-pull and bridge topologies, using voltage-mode control in a small 10-pin package. Features include a start-up regulator, precision 2.5-V reference output, current limit detection, alternating gate drivers, sync capability, thermal shutdown, soft start, and remote shutdown. This high-speed IC has total propagation delays less than 100 ns. These features simplify the design of an open-loop DC-DC converter, or a voltage controlled closed-loop converter.

7.2 Functional Block Diagram



Copyright © 2016, Texas Instruments Incorporated

7.3 Feature Description

7.3.1 High Voltage Start-Up Regulator (VIN and VCC)

The LM5033 contains an internal high-voltage start-up regulator. The input pin (VIN) can be connected directly to line voltages as high as 90 V for normal operation, and can withstand transients to 100 V. The regulator output at VCC, 9.6 V (typical), is internally current limited to 20 mA (minimum). Upon power up, the capacitor at VCC charges up, providing a time delay while internal circuits stabilize. When V_{CC} reaches the upper threshold of the undervoltage sensor (typically 9.5 V), the undervoltage sensor resets, enabling the output drivers, although the PWM duty cycle is initially at zero. As the soft-start capacitor charges up, the output duty cycle increases until regulated by the PWM control loop. The value of the VCC capacitor which affects the start-up delay depends on the total system design and its start-up characteristics. TI recommends the VCC capacitor to be from 0.1 μF to 50 μF.

The lower threshold of the undervoltage sensor is typically at 6.8 V. If V_{CC} falls below this value the outputs are disabled and the soft-start capacitor is discharged. When V_{CC} increases above the upper threshold the outputs are enabled, and the soft-start sequence repeats.

The internal power dissipation of the LM5033 can be reduced by powering VCC from an external supply. Typically this is done by means of an auxiliary transformer winding which is diode connected to the VCC pin to provide 10 V to 15 V as the controller completes the start-up sequence. The externally applied VCC voltage causes the internal regulator to shut off. The undervoltage sensor circuit still functions in this mode, requiring that the external VCC capacitor be sized so that V_{CC} never falls below 6.8 V. The required current into the VCC pin from the external source is shown in [Figure 9](#).

If a fault condition occurs such that the external supply to VCC fails, external current draw from the VCC pin must be limited to not exceed the current limit of the regulator, or the maximum power dissipation of the IC. An external start-up or other bias rail can be used instead of the internal start-up regulator by connecting the VCC and the VIN pins together and feeding the external bias voltage, 10 V to 15 V, into that node.

7.3.2 Reference (REF)

The REF pin provides a reference voltage of 2.5 V ± 2.4%. The pin is internally connected to an NMOS FET drain at the output of the buffer amplifier, allowing it to sink, but not source current. An external pullup resistor is required. Current into the pin must be limited to less than 20 mA to maintain regulation (see [Figure 8](#)).

During start-up if the pullup voltage is present before the reference amplifier establishes regulation, the voltage on REF must not exceed 5.5 V. If this reference is not used the REF pin can float or be connected to ground.

7.3.3 PWM Comparator (COMP), Duty Cycle and Deadtime

The PWM comparator compares an internal ramp signal, 0 V to 0.65 V, with the loop-error voltage derived from the COMP pin. The COMP voltage is typically set by an external error amplifier through an optocoupler for closed-loop applications. Internally, the voltage at the COMP pin passes through two level shifting diodes, and a gain reducing, 3:1 resistor divider. The output of the PWM comparator provides the pulse width information to the output drivers (OUT1 and OUT2). This comparator is optimized for speed to achieve minimum discernable duty cycles. The output duty cycle is 0% for V_{COMP} < 1.5 V, and maximum for V_{COMP} > 3.5 V (see [Figure 7](#)). The maximum duty cycle for each output is limited to less than 50% due to the forced deadtime. The typical deadtime from the falling edge of one gate driver output to the rising edge of the other gate driver output is 135 ns, and does not vary with frequency. The maximum duty cycle for each output can be calculated with [Equation 1](#).

$$DC = \frac{(0.5 \times t_S) - t_D}{t_S}$$

where

- t_S is the period of each output
- t_D is the deadtime

(1)

For example, if the oscillator frequency is 200 kHz, each output cycles at 100 kHz, and t_S = 10 μs. Using the nominal deadtime of 135 ns, the maximum duty cycle at this frequency is 48.65%. Using the minimum deadtime of 85 ns, the maximum duty cycle increases to 49.15%.

Feature Description (continued)

When the SS pin is pulled down, internally or externally, the COMP pin voltage is pulled down with it, with a difference of 0.5 V. When SS voltage increases the COMP voltage is allowed to increase, pulled up by an internal 5.2-V supply through a 5-kΩ resistor.

In an open-loop application, such as an intermediate bus converter, COMP can be left open resulting in maximum duty cycle at the output drivers.

7.3.4 Current Sense (CS)

The current sense circuit is intended to protect the power converter when an abnormal primary current is sensed by initiating a low duty cycle hiccup mode. When the threshold, 0.5 V, at CS is exceeded the outputs are disabled, and the soft-start capacitor is internally discharged. When the soft-start capacitor is fully discharged and the voltage at the CS pin is below 0.5 V, the outputs are re-enabled allowing the soft-start capacitor voltage and the output duty cycle to increase.

The external current sensing circuit must include an RC filter placed near the IC to prevent false triggering of the current sense comparator due to transients or noise. An internal MOSFET discharges the external filter capacitor at the conclusion of each PWM cycle to improve dynamic performance. The discharge time is equal to the deadtime between OUT1 and OUT2 at maximum duty cycle. Additionally, CS is pulled low when V_{CC} is below the undervoltage threshold or when an overtemperature condition occurs.

7.3.5 Oscillator, Sync Capability (RT/SYNC)

The LM5033 oscillator frequency is set by a single external resistor (R_T) connected between RT/SYNC and ground. The value of the required R_T resistor is calculated with [Equation 2](#).

$$R_T = \frac{\frac{1}{F_{OSC}} - 172 \times 10^{-9}}{182 \times 10^{-12}}$$

where

- F_{OSC} is the desired oscillator frequency (2)

The outputs (OUT1 and OUT2) alternate at half the oscillator frequency. The voltage at the RT/SYNC pin is internally regulated to a nominal 2 V. The R_T resistor must be placed as close as possible to the IC, and connected directly to the pins (RT/SYNC and GND).

The LM5033 can be synchronized to an external clock by applying a narrow pulse to RT/SYNC. The external clock must be a higher frequency than the free running frequency set by the R_T resistor, and the pulse width must be from 15 ns to 150 ns. The clock signal must be coupled into the RT/SYNC pin through a 100-pF capacitor. When the synchronizing pulse transitions low-to-high, the voltage at RT/SYNC must exceed 3.8 V from its nominal 2-V DC level. During the clock signal low time the voltage at RT/SYNC is clamped at 2 V by an internal regulator. The R_T resistor is always required, whether the oscillator is free running or externally synchronized.

7.3.6 Soft Start (SS)

The soft-start feature allows the converter to gradually reach a steady state operating point, thereby reducing start-up stresses and current surges. Upon turnon, after the undervoltage sensor resets at V_{CC}, an internal 10-μA current source charges an external capacitor at SS to generate a ramping voltage, 0 V to 5 V, which allows the voltage on the COMP pin to increase gradually. As the COMP voltage increases the output duty cycle increases from zero to the value required for regulation. Internally, the SS pin is pulled low when a current fault is detected at CS, the V_{CC} voltage is below the lower threshold of the under-voltage sensor, or when a thermal shutdown occurs. Additionally, the SS pin can be pulled low by an external device.

In the event of a current fault, the soft-start capacitor is discharged by an internal pulldown device (see [Current Sense \(CS\)](#)). The falling voltage at SS pulls down the COMP pin, ensuring a minimum output duty cycle when the outputs are re-enabled. Then the soft-start capacitor begins to ramp up, allowing the COMP voltage to increase. As the COMP voltage increases, the output duty cycle increases from zero to the value required for regulation. However, if the fault condition is still present the above sequence repeats until the fault is removed.

Feature Description (continued)

If the VCC voltage falls below the lower undervoltage sensor threshold, typically 6.8 V, the outputs are disabled, and the soft-start capacitor is discharged. The falling voltage at SS pulls down the COMP pin, thereby ensuring minimum output duty cycle when the outputs are re-enabled. After the VCC voltage increases above the upper threshold, typically 9.5 V, the outputs are enabled, and the soft-start capacitor begins to ramp up, allowing the COMP pin voltage to increase. The output duty cycle then increases from zero to the value required for regulation.

In the event of a fault which results in an excessively high die temperature, an internal thermal shutdown circuit is provided to protect the IC. See [Thermal Protection](#) for more information.

Using an externally controlled switch, the outputs (OUT1 and OUT2) can be disabled at any time by pulling SS below 0.5 V. This pulls down the COMP pin to near ground, causing the output duty cycle to go to zero. Upon releasing SS, the soft-start capacitor ramps up, allowing the COMP pin voltage to increase. The output duty cycle then increases from zero to the value required for regulation.

7.3.7 OUT1 and OUT2

The LM5033 provides two alternating outputs, OUT1 and OUT2, each capable of sourcing and sinking 1.5-A peak current. Each toggles at one-half the internal oscillator frequency. The voltage output levels are nominally ground and V_{CC} , minus a saturation voltage at each level which depends on the current flow.

The outputs can drive power MOSFETs directly in a push-pull application, or they can drive a high voltage gate driver (for example, LM5100) in a bridge application.

The outputs are disabled when any of the following conditions occur:

1. An overcurrent condition is detected at CS.
2. The VCC undervoltage sensor is active.
3. An overtemperature condition is detected.
4. The voltage at SS is below 0.5 V.

7.3.8 Thermal Protection

The system design must limit the LM5033 junction temperature to not exceed 125°C during normal operation. However, in the event of a fault which results in a higher die temperature, an internal thermal shutdown circuit is provided to protect the IC. When thermal shutdown is activated, typically at 165°C, the IC is forced into a low power reset state disabling the output drivers and the VCC regulator. This feature helps prevent catastrophic failures from accidental device overheating. When the die temperature drops below 150°C, typical hysteresis is 15°C, the VCC regulator is enabled and a soft-start sequence initiates.

7.4 Device Functional Modes

The LM5033 is a versatile PWM controller that can be used as a half-bridge PWM controller or as a push-pull PWM controller. The LM5033 delivers 180° out-of-phase ground-referenced PWM signals to the gates of power MOSFETs. The LM5033 can also operate in conjunction with a high-side driver, for example, LM5100, to implement in a half-bridge application.

8 Application and Implementation

NOTE

Information in the following applications sections is not part of the TI component specification, and TI does not warrant its accuracy or completeness. TI's customers are responsible for determining suitability of components for their purposes. Customers should validate and test their design implementation to confirm system functionality.

8.1 Application Information

The following information is intended to provide guidelines for implementing the LM5033. However, final selection of all external components is dependent on the configuration and operating characteristics of the complete power conversion system.

8.2 Typical Application

Figure 11 shows an example circuit for a half-bridge, 200-W, DC-DC converter built in a quarter brick format. The circuit is that of an intermediate bus converter (IBC) which operates open-loop (unregulated output), converting a nominal 48-V input to a nominal 9-V output with a 30-mΩ output impedance. The current sense transformer (T2), and the associated filter at the CS pin, provide overcurrent detection at approximately 23 A. The auxiliary winding on T1 powers VCC and the LM5100's V+ pin (once the outputs are enabled) to reduce power dissipation within the LM5033. The LM5100 provides appropriate level shifting for Q1. Synchronous rectifiers Q3 and Q4 minimize conduction losses in the output stage. Dual comparators U2 and U3 provide undervoltage and overvoltage sensing at VIN. The undervoltage sense levels are 37 V increasing, and 33 V decreasing. The overvoltage sense levels are 63 V increasing, and 61.5 V decreasing. The circuit can be shut down by taking the ON/OFF input below 0.8 V. An external synchronizing frequency can be applied to the SYNC input. Measured efficiency and output characteristics for this circuit are shown in Figure 14 and Figure 15.

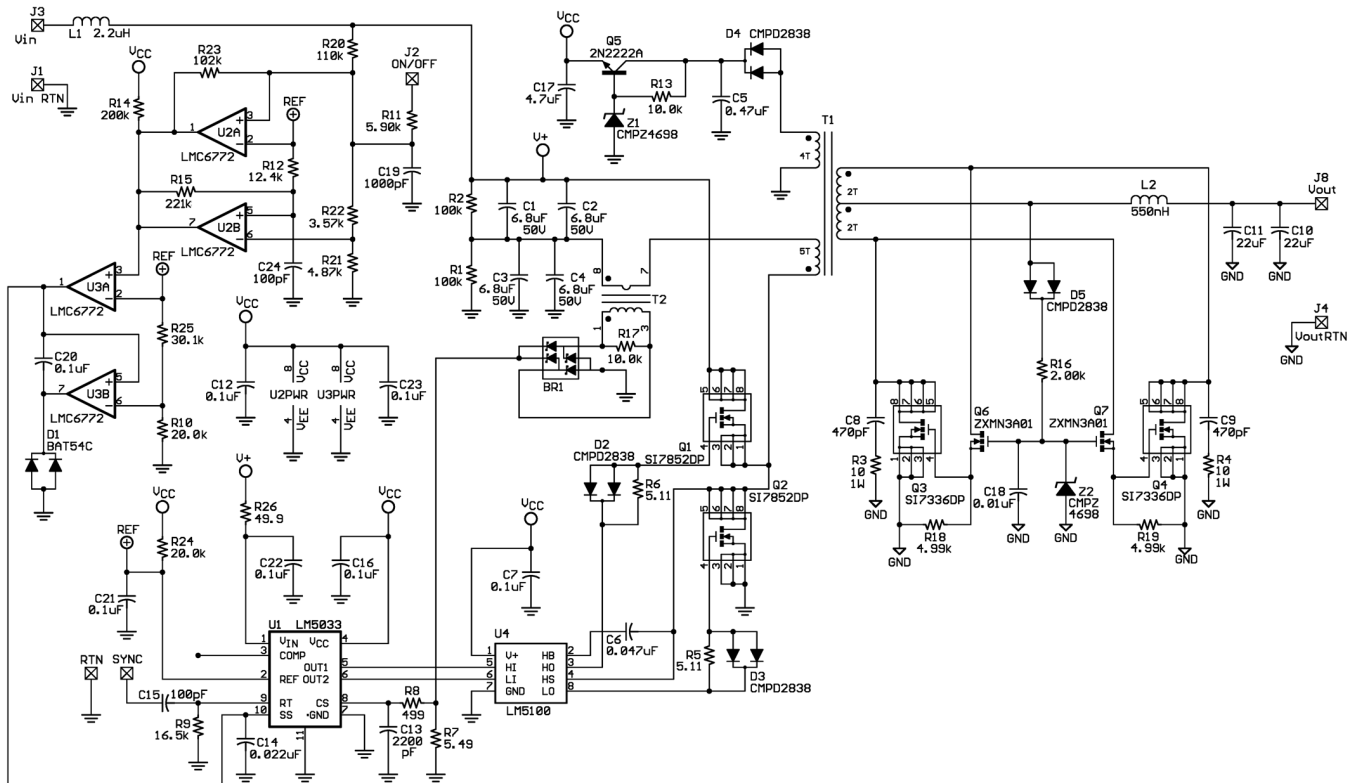

Copyright © 2016, Texas Instruments Incorporated

**Figure 11. Intermediate Bus Converter
40-V to 60-V Input; 7.5-V to 11.3-V, 20-A Output**

Typical Application (continued)

8.2.1 Design Requirements

Table 1 lists the input parameters for this design example.

Table 1. Example Parameters

PARAMETER	MIN	NOM	MAX	UNIT
Input voltage, V_{IN}	40	48	60	V
Output voltage, V_{OUT}	7.5	9	11.3	V
Output current, I_{OUT}	0		20	A
Output current limit, I_{LIMIT}		23		A
Load regulation		±4%		
Oscillator frequency		315		kHz
Switching frequency		157		kHz

8.2.2 Detailed Design Procedure

8.2.2.1 V_{IN}

The voltage applied at V_{IN} , normally the same as that applied to the primary of the main transformer, can be from 15 V to 90 V, with transient capability to 100 V. The current into V_{IN} depends not only on V_{IN} , but also on the load on the output driver pins, any load on V_{CC} , and whether or not an external voltage is applied to V_{CC} . If V_{IN} is close to the absolute maximum rating of the LM5033, TI recommends the circuit of Figure 12 be used to filter transients which may occur at the input supply.

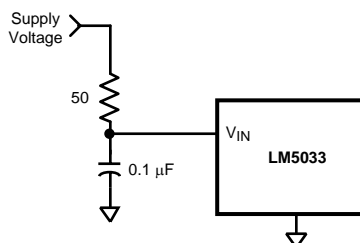

Figure 12. Input Transient Protection

If V_{CC} is not powered externally, requiring all internal bias currents for the LM5033, and output driver currents, to be supplied at V_{IN} and through the internal regulator, the required input current (I_{IN}) is shown in Figure 10.

If V_{CC} is powered externally, I_{IN} increases with V_{IN} as shown in Figure 9 until the external voltage is applied to V_{CC} . In most applications, this occurs once the outputs are enabled and load current begins to flow. The current into V_{IN} then drops to a nominal 150 μ A; SS is either open or grounded.

8.2.2.2 V_{CC}

The capacitor at the V_{CC} pin provides not only noise filtering and stability, but also a necessary time delay during start-up. The time delay allows the internal circuitry of the LM5033, and associated external circuitry, to stabilize before V_{CC} reaches its final value, at which time the outputs are enabled and the soft-start sequence begins. Any external circuitry connected to the REF output and SS must be designed to stabilize during the time delay.

The current limit of the V_{CC} regulator, and the external capacitor, determine the V_{CC} turnon time delay. Typically, a 1- μ F capacitor provides approximately 300 μ s of delay, with larger capacitors providing proportionately longer delays. Experimentation with the final design may be necessary to determine the minimum value for the V_{CC} capacitor.

8.2.2.3 Soft Start (SS)

The capacitor at SS determines the time required for the output duty cycle to increase from zero to the final value for regulation. The minimum acceptable time is dependent on the response of the feedback loops to the COMP pin, as well as the characteristics of the magnetic components. If the soft-start time is too quick, the system output could significantly overshoot its intended voltage before the loop is able to establish regulation, possibly adversely affecting the load. Experimentation with the final design is usually necessary to determine the minimum value for the SS capacitor.

8.2.2.4 Current Sense (CS)

This pin typically receives an input representative of the primary current from the current sense elements of the external circuitry. The peak amplitude at this pin must be less than 0.5 V for normal operation. Filtering at this pin must be sufficient to prevent false triggering of the current sense comparator, but not significantly delay detection of an overcurrent condition. The filter's capacitor at CS must not be larger than 2200 pF.

8.2.2.5 Oscillator, Sync Input (RT/SYNC)

The internal oscillator frequency is generally selected in conjunction with the system magnetic components, and any other aspects of the system which may be affected by the frequency. The R_T resistor at RT/SYNC sets the frequency according to [Equation 2](#). Each output (OUT1 and OUT2) switches at half the oscillator frequency. If the required frequency value is critical in a particular application, the tolerance of the external resistor, and the frequency tolerance indicated in [Electrical Characteristics](#), must be taken into account when selecting the resistor.

If the LM5033 is to be synchronized to an external clock, that signal must be coupled into RT/SYNC through a 100-pF capacitor. The R_T resistor is still required in this case, and it must be selected to set the internal oscillator to a frequency lower than the external synchronizing frequency. The amplitude of the external pulses must take RT/SYNC above 3.8 V on the low-to-high transition but no higher than 5.5 V. The clock pulse width must be from 15 ns to 150 ns.

8.2.2.6 Deadtime Adjustment

TI recommends the circuits in [Figure 13](#) if the application requires a change in the minimum deadtime between the outputs. Suggested values for the resistor and capacitor at each output are 500 Ω , and 100 pF, respectively for a nominal 50-ns change. The diodes can be 1N4148, or similar.

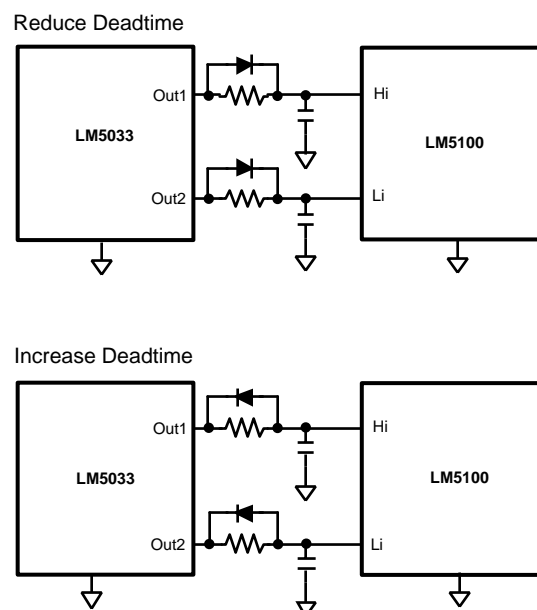
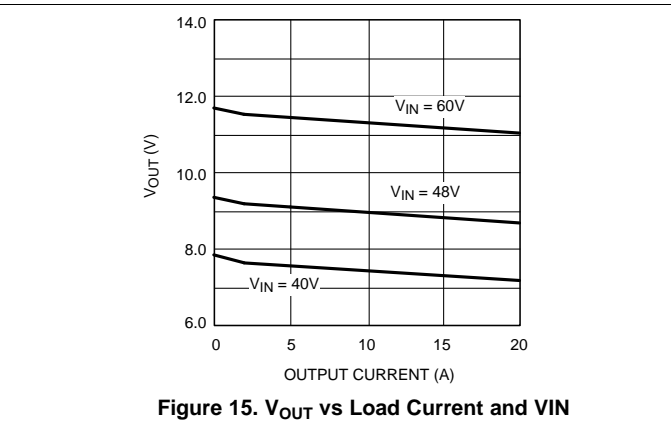
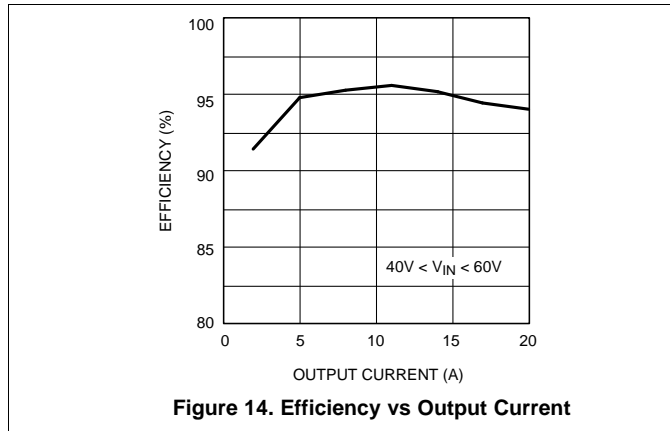

Figure 13. Deadtime Adjustment

8.2.3 Application Curves



9 Power Supply Recommendations

The VCC pin requires a local decoupling capacitor that is connected to GND. This capacitor ensures stability of the internal regulator from the VIN pin. The decoupling capacitor also provides the current pulses to drive the gates of the external MOSFETs through the driver output (OUT1 and OUT2) pins. The decoupling capacitor must be placed close to the VCC and GND pins, and must be tracked directly to the pins.

10 Layout

10.1 Layout Guidelines

The LM5033 current sense and PWM comparators are very fast, and as such responds to short-duration noise pulses. Layout considerations are critical for the current sense filter. The components at COMP, CS, RT/SYNC, and SS pins must be placed as close as possible to the IC, thereby minimizing noise pickup in the printed-circuit tracks.

If a current sense transformer is used both leads of the transformer secondary must be routed to the sense filter components, and to the IC pins. The ground side of the transformer must be connected through a dedicated printed-circuit track to GND of the IC rather than through the ground plane.

If the current sense circuit employs a sense resistor in the drive transistor sources, a low-inductance resistor must be used. In this case all the noise-sensitive low-power grounds must be connected in common near the IC, and then a single connection made to the power ground (sense resistor ground point).

The outputs of the LM5033, or of the high-voltage gate driver (if used), must have short, direct paths to the power MOSFETs to minimize the effects of inductance in the PCB traces.

If the internal dissipation of the LM5033 and any of the power devices produces high junction temperatures during normal operation, good use of the PCB ground plane can help considerably to dissipate heat. The exposed pad on the bottom of the 10-pin WSON package can be soldered to the ground plane on the PCB, and the ground plane must extend out from beneath the IC to help dissipate the heat. The exposed pad is internally connected to the IC substrate.

Additionally, the use of wide PCB traces where possible can help conduct heat away from the IC. Judicious positioning of the PCB within the end product, along with use of any available air flow (forced or natural convection) can help reduce the junction temperatures.

10.2 Layout Example

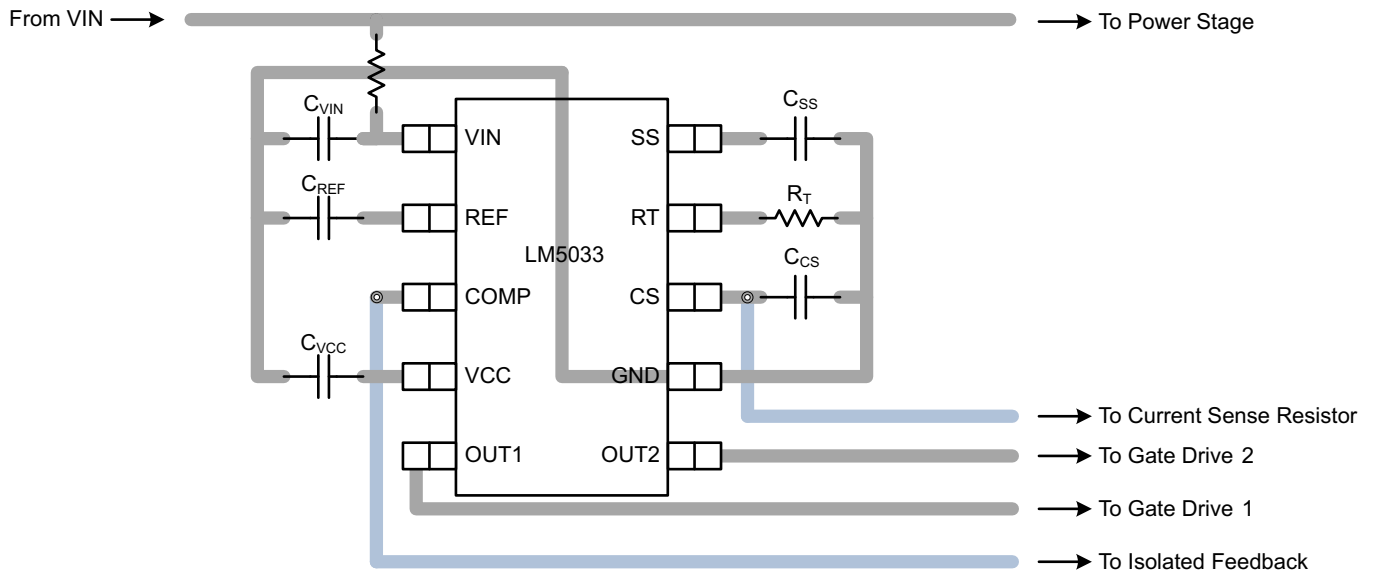

Copyright © 2016, Texas Instruments Incorporated

Figure 16. Layout Recommendation

11 Device and Documentation Support

11.1 Documentation Support

11.1.1 Related Documentation

For related documentation see the following:

[AN-1187 Leadless Leadframe Package \(LLP\) \(SNOA401\)](#)

11.2 Receiving Notification of Documentation Updates

To receive notification of documentation updates, navigate to the device product folder on ti.com. In the upper right corner, click on *Alert me* to register and receive a weekly digest of any product information that has changed. For change details, review the revision history included in any revised document.

11.3 Community Resources

The following links connect to TI community resources. Linked contents are provided "AS IS" by the respective contributors. They do not constitute TI specifications and do not necessarily reflect TI's views; see TI's [Terms of Use](#).

TI E2E™ Online Community *TI's Engineer-to-Engineer (E2E) Community*. Created to foster collaboration among engineers. At e2e.ti.com, you can ask questions, share knowledge, explore ideas and help solve problems with fellow engineers.

Design Support *TI's Design Support* Quickly find helpful E2E forums along with design support tools and contact information for technical support.

11.4 Trademarks

E2E is a trademark of Texas Instruments.
All other trademarks are the property of their respective owners.

11.5 Electrostatic Discharge Caution



These devices have limited built-in ESD protection. The leads should be shorted together or the device placed in conductive foam during storage or handling to prevent electrostatic damage to the MOS gates.

11.6 Glossary

[SLYZ022](#) — *TI Glossary*.

This glossary lists and explains terms, acronyms, and definitions.

12 Mechanical, Packaging, and Orderable Information

The following pages include mechanical, packaging, and orderable information. This information is the most current data available for the designated devices. This data is subject to change without notice and revision of this document. For browser-based versions of this data sheet, refer to the left-hand navigation.

PACKAGING INFORMATION

Orderable part number	Status (1)	Material type (2)	Package Pins	Package qty Carrier	RoHS (3)	Lead finish/ Ball material (4)	MSL rating/ Peak reflow (5)	Op temp (°C)	Part marking (6)
LM5033MM/NOPB	Obsolete	Production	VSSOP (DGS) 10	-	-	Call TI	Call TI	-40 to 125	SCVB
LM5033MMX/NOPB	Active	Production	VSSOP (DGS) 10	3500 LARGE T&R	Yes	SN	Level-1-260C-UNLIM	-40 to 125	SCVB
LM5033MMX/NOPB.A	Active	Production	VSSOP (DGS) 10	3500 LARGE T&R	Yes	SN	Level-1-260C-UNLIM	-40 to 125	SCVB
LM5033MMX/NOPB.B	Active	Production	VSSOP (DGS) 10	3500 LARGE T&R	Yes	SN	Level-1-260C-UNLIM	-40 to 125	SCVB
LM5033SD/NOPB	Obsolete	Production	WSON (DPR) 10	-	-	Call TI	Call TI	-40 to 125	5033SD
LM5033SDX/NOPB	Active	Production	WSON (DPR) 10	4500 LARGE T&R	Yes	SN	Level-1-260C-UNLIM	-40 to 125	5033SD
LM5033SDX/NOPB.A	Active	Production	WSON (DPR) 10	4500 LARGE T&R	Yes	SN	Level-1-260C-UNLIM	-40 to 125	5033SD
LM5033SDX/NOPB.B	Active	Production	WSON (DPR) 10	4500 LARGE T&R	Yes	SN	Level-1-260C-UNLIM	-40 to 125	5033SD

(1) **Status:** For more details on status, see our [product life cycle](#).

(2) **Material type:** When designated, preproduction parts are prototypes/experimental devices, and are not yet approved or released for full production. Testing and final process, including without limitation quality assurance, reliability performance testing, and/or process qualification, may not yet be complete, and this item is subject to further changes or possible discontinuation. If available for ordering, purchases will be subject to an additional waiver at checkout, and are intended for early internal evaluation purposes only. These items are sold without warranties of any kind.

(3) **RoHS values:** Yes, No, RoHS Exempt. See the [TI RoHS Statement](#) for additional information and value definition.

(4) **Lead finish/Ball material:** Parts may have multiple material finish options. Finish options are separated by a vertical ruled line. Lead finish/Ball material values may wrap to two lines if the finish value exceeds the maximum column width.

(5) **MSL rating/Peak reflow:** The moisture sensitivity level ratings and peak solder (reflow) temperatures. In the event that a part has multiple moisture sensitivity ratings, only the lowest level per JEDEC standards is shown. Refer to the shipping label for the actual reflow temperature that will be used to mount the part to the printed circuit board.

(6) **Part marking:** There may be an additional marking, which relates to the logo, the lot trace code information, or the environmental category of the part.

Multiple part markings will be inside parentheses. Only one part marking contained in parentheses and separated by a "-" will appear on a part. If a line is indented then it is a continuation of the previous line and the two combined represent the entire part marking for that device.

Important Information and Disclaimer: The information provided on this page represents TI's knowledge and belief as of the date that it is provided. TI bases its knowledge and belief on information provided by third parties, and makes no representation or warranty as to the accuracy of such information. Efforts are underway to better integrate information from third parties. TI has taken and continues to take reasonable steps to provide representative and accurate information but may not have conducted destructive testing or chemical analysis on incoming materials and chemicals. TI and TI suppliers consider certain information to be proprietary, and thus CAS numbers and other limited information may not be available for release.

In no event shall TI's liability arising out of such information exceed the total purchase price of the TI part(s) at issue in this document sold by TI to Customer on an annual basis.

TAPE AND REEL INFORMATION



QUADRANT ASSIGNMENTS FOR PIN 1 ORIENTATION IN TAPE



*All dimensions are nominal

Device	Package Type	Package Drawing	Pins	SPQ	Reel Diameter (mm)	Reel Width W1 (mm)	A0 (mm)	B0 (mm)	K0 (mm)	P1 (mm)	W (mm)	Pin1 Quadrant
LM5033MMX/NOPB	VSSOP	DGS	10	3500	330.0	12.4	5.3	3.4	1.4	8.0	12.0	Q1
LM5033SDX/NOPB	WSOP	DPR	10	4500	330.0	12.4	4.3	4.3	1.3	8.0	12.0	Q1

TAPE AND REEL BOX DIMENSIONS



*All dimensions are nominal

Device	Package Type	Package Drawing	Pins	SPQ	Length (mm)	Width (mm)	Height (mm)
LM5033MMX/NOPB	VSSOP	DGS	10	3500	367.0	367.0	35.0
LM5033SDX/NOPB	WSON	DPR	10	4500	367.0	367.0	35.0

DGS0010A



PACKAGE OUTLINE

VSSOP - 1.1 mm max height

SMALL OUTLINE PACKAGE

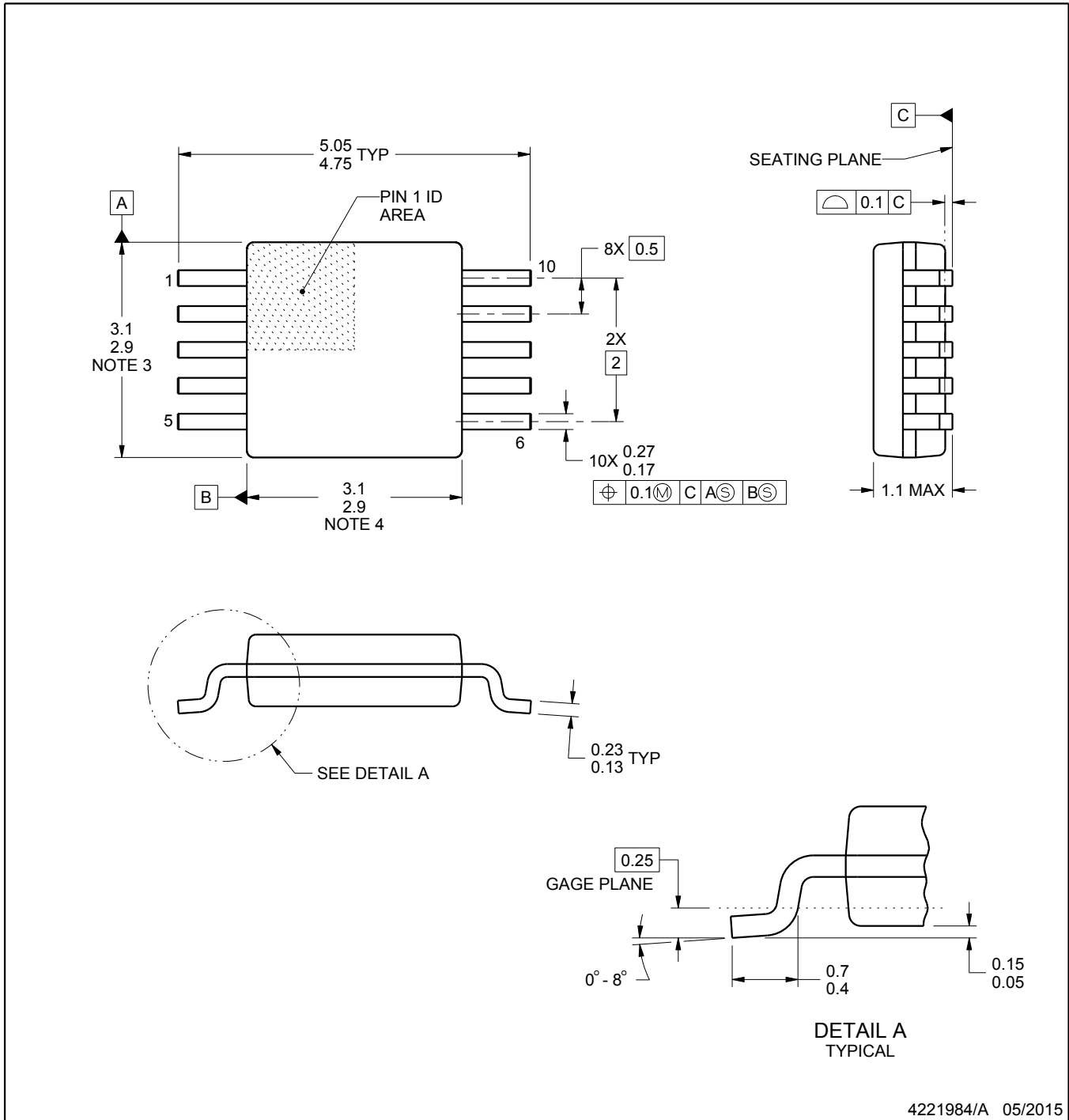

4221984/A 05/2015

NOTES:

1. All linear dimensions are in millimeters. Any dimensions in parenthesis are for reference only. Dimensioning and tolerancing per ASME Y14.5M.
2. This drawing is subject to change without notice.
3. This dimension does not include mold flash, protrusions, or gate burrs. Mold flash, protrusions, or gate burrs shall not exceed 0.15 mm per side.
4. This dimension does not include interlead flash. Interlead flash shall not exceed 0.25 mm per side.
5. Reference JEDEC registration MO-187, variation BA.

EXAMPLE BOARD LAYOUT

DGS0010A

VSSOP - 1.1 mm max height

SMALL OUTLINE PACKAGE

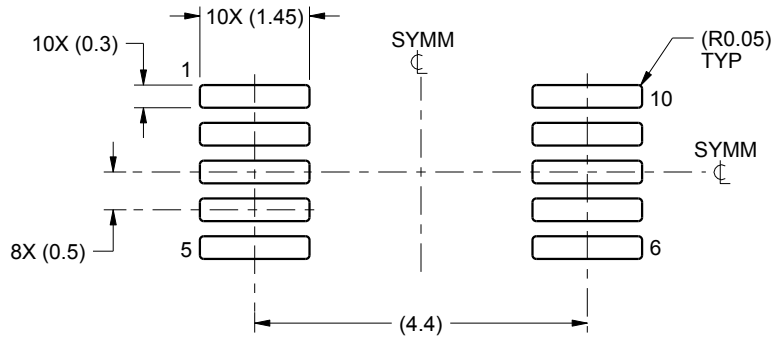

LAND PATTERN EXAMPLE
SCALE:10X

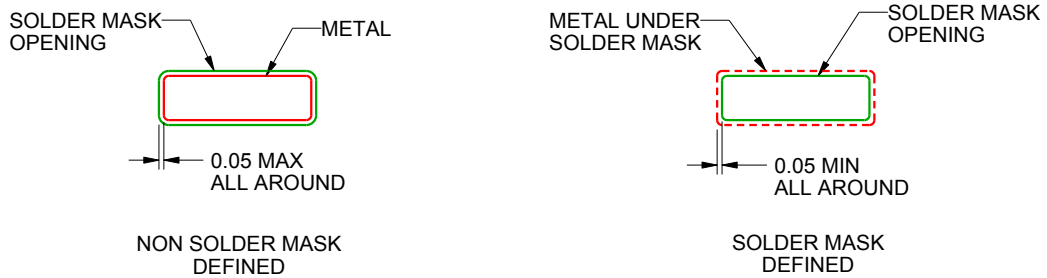

SOLDER MASK DETAILS
NOT TO SCALE

4221984/A 05/2015

NOTES: (continued)

- 6. Publication IPC-7351 may have alternate designs.
- 7. Solder mask tolerances between and around signal pads can vary based on board fabrication site.

EXAMPLE STENCIL DESIGN

DGS0010A

VSSOP - 1.1 mm max height

SMALL OUTLINE PACKAGE

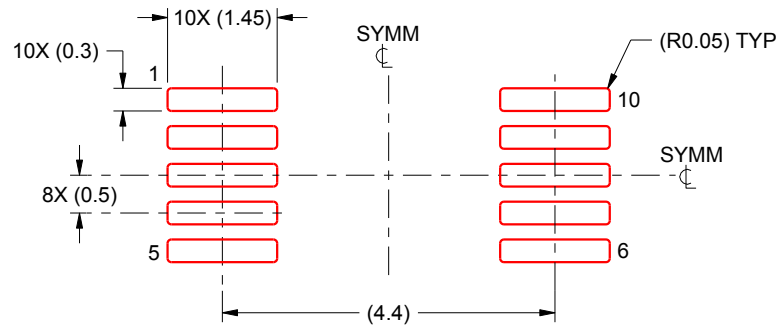

SOLDER PASTE EXAMPLE
BASED ON 0.125 mm THICK STENCIL
SCALE:10X

4221984/A 05/2015

NOTES: (continued)

8. Laser cutting apertures with trapezoidal walls and rounded corners may offer better paste release. IPC-7525 may have alternate design recommendations.
9. Board assembly site may have different recommendations for stencil design.

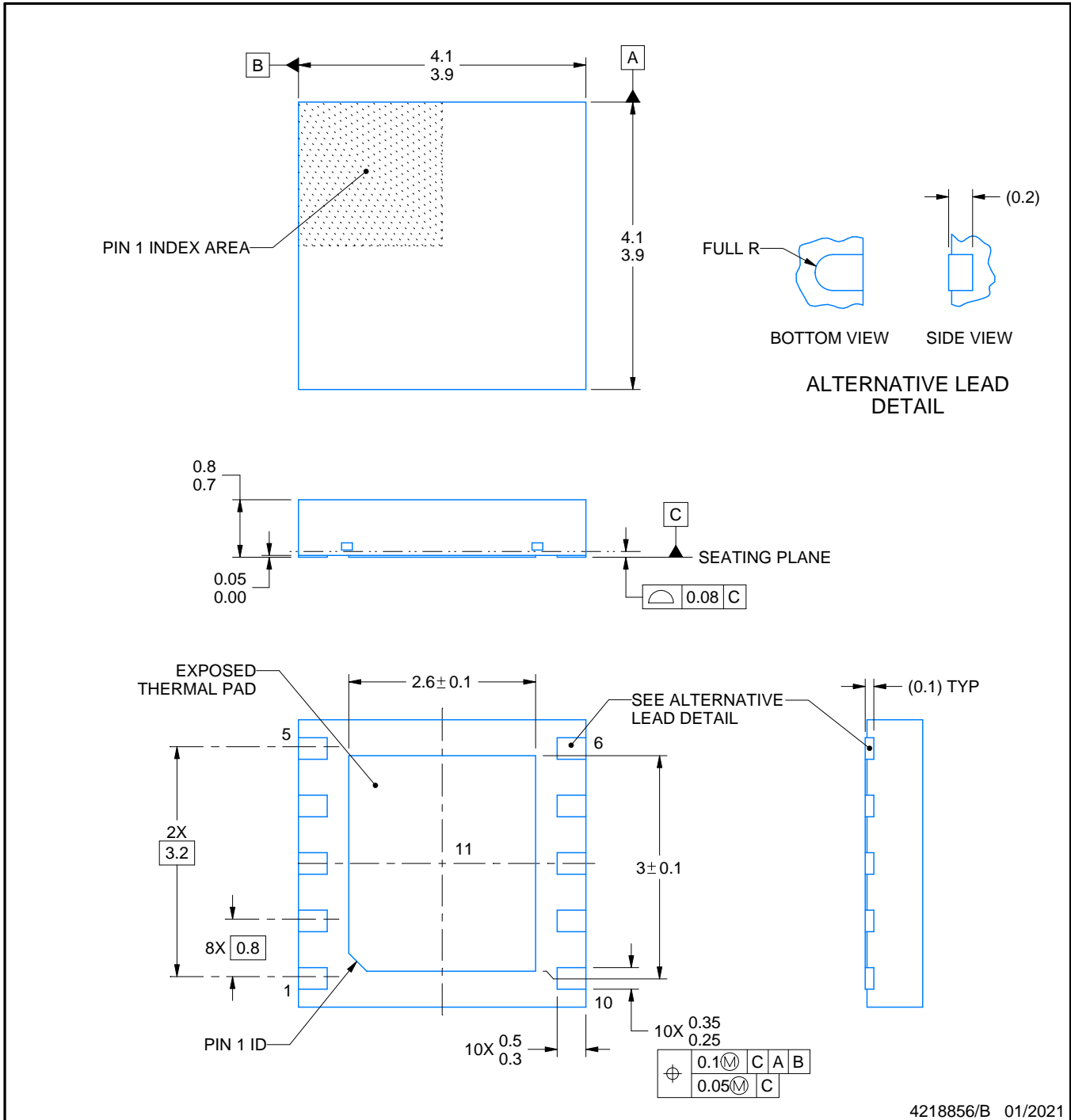
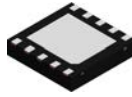

4218856/B 01/2021

NOTES:

1. All linear dimensions are in millimeters. Any dimensions in parenthesis are for reference only. Dimensioning and tolerancing per ASME Y14.5M.
2. This drawing is subject to change without notice.
3. The package thermal pad must be soldered to the printed circuit board for thermal and mechanical performance.

EXAMPLE BOARD LAYOUT

DPR0010A

WSON - 0.8 mm max height

PLASTIC SMALL OUTLINE - NO LEAD

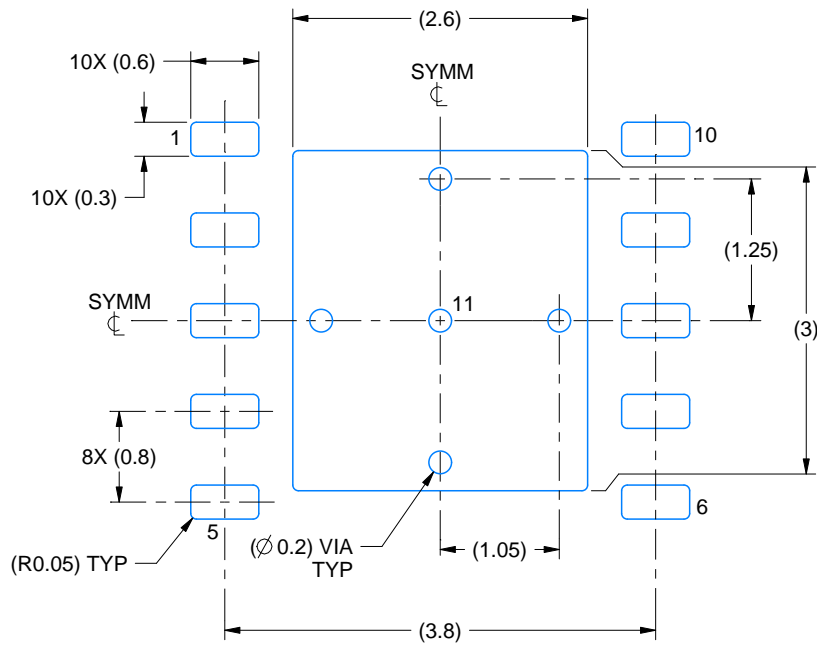

LAND PATTERN EXAMPLE
EXPOSED METAL SHOWN
SCALE:15X

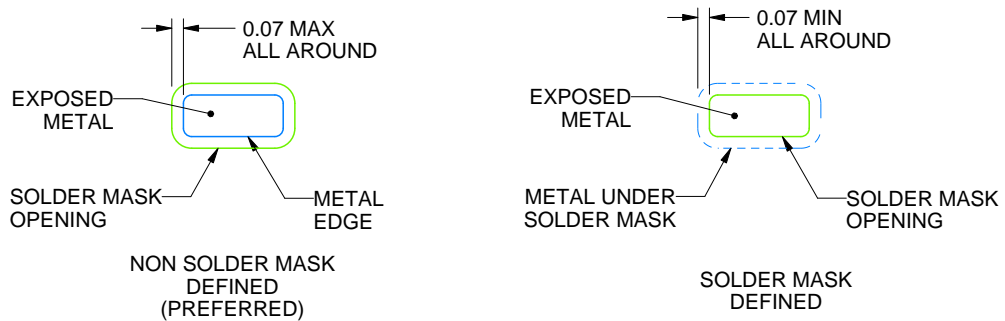

SOLDER MASK DETAILS

4218856/B 01/2021

NOTES: (continued)

4. This package is designed to be soldered to a thermal pad on the board. For more information, see Texas Instruments literature number SLUA271 (www.ti.com/lit/slua271).

EXAMPLE STENCIL DESIGN

DPR0010A

WSN - 0.8 mm max height

PLASTIC SMALL OUTLINE - NO LEAD

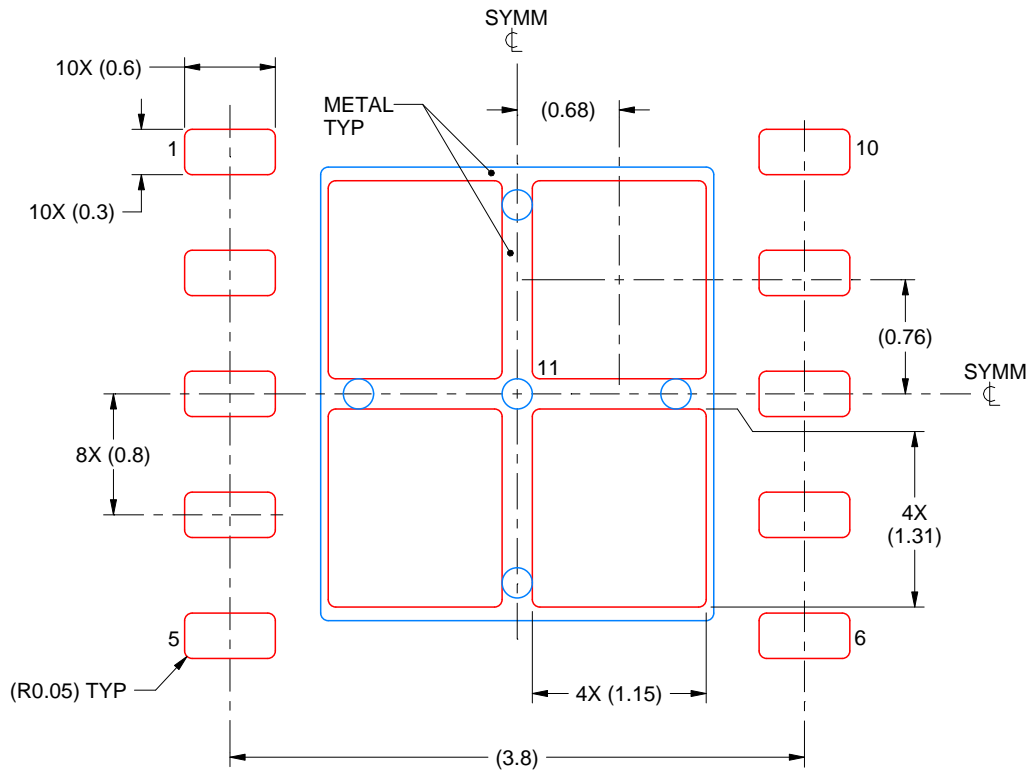

SOLDER PASTE EXAMPLE
BASED ON 0.125 mm THICK STENCIL

EXPOSED PAD 11:
77% PRINTED SOLDER COVERAGE BY AREA
SCALE:20X

4218856/B 01/2021

NOTES: (continued)

5. Laser cutting apertures with trapezoidal walls and rounded corners may offer better paste release. IPC-7525 may have alternate design recommendations.

IMPORTANT NOTICE AND DISCLAIMER

TI PROVIDES TECHNICAL AND RELIABILITY DATA (INCLUDING DATASHEETS), DESIGN RESOURCES (INCLUDING REFERENCE DESIGNS), APPLICATION OR OTHER DESIGN ADVICE, WEB TOOLS, SAFETY INFORMATION, AND OTHER RESOURCES "AS IS" AND WITH ALL FAULTS, AND DISCLAIMS ALL WARRANTIES, EXPRESS AND IMPLIED, INCLUDING WITHOUT LIMITATION ANY IMPLIED WARRANTIES OF MERCHANTABILITY, FITNESS FOR A PARTICULAR PURPOSE OR NON-INFRINGEMENT OF THIRD PARTY INTELLECTUAL PROPERTY RIGHTS.

These resources are intended for skilled developers designing with TI products. You are solely responsible for (1) selecting the appropriate TI products for your application, (2) designing, validating and testing your application, and (3) ensuring your application meets applicable standards, and any other safety, security, regulatory or other requirements.

These resources are subject to change without notice. TI grants you permission to use these resources only for development of an application that uses the TI products described in the resource. Other reproduction and display of these resources is prohibited. No license is granted to any other TI intellectual property right or to any third party intellectual property right. TI disclaims responsibility for, and you fully indemnify TI and its representatives against any claims, damages, costs, losses, and liabilities arising out of your use of these resources.

TI's products are provided subject to [TI's Terms of Sale](#), [TI's General Quality Guidelines](#), or other applicable terms available either on [ti.com](#) or provided in conjunction with such TI products. TI's provision of these resources does not expand or otherwise alter TI's applicable warranties or warranty disclaimers for TI products. Unless TI explicitly designates a product as custom or customer-specified, TI products are standard, catalog, general purpose devices.

TI objects to and rejects any additional or different terms you may propose.

Copyright © 2026, Texas Instruments Incorporated

Last updated 10/2025