

MCF8329HS Sensorless Field Oriented Control (FOC) Three-Phase BLDC Gate Driver

1 Features

- **Functional Safety Quality-Managed Targeted** (only MCF8329HSULIREER)
 - Documentation available to aid IEC-60730-1 functional safety system design
- Safety-Related Certifications (only MCF8329HSULIREER)
 - UL recognized component: UL 60730-1 (File Number: E546206)
- Safety functions (only MCF8329HSULIREER)
 - Locked rotor protection
 - Over current (over load) protection
 - Loss of phase (no motor)
- Three-phase BLDC gate driver with integrated sensorless motor control algorithm
 - Code-free Field Oriented Control (FOC)
 - Supports up to 2.5kHz (electrical frequency)
 - Speed, current, power or voltage control modes
 - Forward and reverse windmilling support
 - Configurable power and speed limit
 - Analog, PWM, freq. or I²C based control input
 - Configurable dry run detection for pumps
 - External MCU watchdog monitoring with limp home mode
 - Optional 1-Hall input support
 - 5-point configurable reference profile support
 - Anti-voltage surge and active braking
 - Flux weakening for high speed operation
 - Maximum torque per ampere (MTPA)
- 65V Three phase half-bridge gate driver
 - 4.5 to 60V op. voltage
 - Bootstrap arch. with 100% duty support
 - 1A/2A peak source/sink current
- Current sense amplifier with adj. gain
- Low power sleep mode: 5µA (max.) at 24V, 25°C
- Speed loop accuracy: < 3% with internal clock
- Configurable EEPROM with R/W security
- Support up to 80kHz PWM switching frequency
- Configurable LDO: (3.3V or 5V) ± 3%, 80mA
- Independent driver shutdown path (DRVOFF)
- Spread spectrum and PWM dithering for EMI mitigation
- Suite of integrated protection features
 - Undervoltage protection on all supply rails
 - Loss of phase (no motor) detection including lost phase(s) information
 - Short-circuit protection (VDS) for all 6 FETs
 - Motor lock detection
 - Thermal shutdown (TSD)
 - Fault indication on nFAULT or FG pin
 - Optional fault diagnostics over I²C interface

2 Applications

- [Cordless Vacuum Cleaners](#)
- [Washer and Dishwasher Pumps](#)
- [Appliance Fans and Pumps](#)
- [Cordless Garden and Power Tools, Lawnmowers](#)

3 Description

The MCF8329HS provides a single-chip, code-free sensorless FOC device for driving 12V or 24V automotive brushless-DC motors (BLDC) or Permanent Magnet Synchronous motors (PMSM) up to 2.5kHz (electrical speed). The MCF8329HS provide three half-bridge gate drivers, each capable of driving high-side and low-side N-channel power MOSFETs. A trickle charge pump is included to support 100% duty cycle. The MCF8329HS can operate from a single power supply.

The algorithm configuration can be stored in non-volatile EEPROM, which allows the device to operate stand-alone once the device has been configured. There are a large number of protection features integrated into the MCF8329HS, intended to protect the device, motor, and system against fault events.

MCF8329HS is available in a 36-pin, 0.4mm pin pitch, 5x4mm, WQFN package (REE).

Device Information (1)

PART NUMBER	PACKAGE	PACKAGE SIZE (2)
MCF8329HSIREER	WQFN (36)	5.00mm × 4.00mm
MCF8329HSULIREER	WQFN (36)	5.00mm × 4.00mm

- (1) For all available packages, see the orderable addendum at the end of the data sheet.
- (2) The package size (length × width) is a nominal value and includes pins, where applicable.

Documentation for reference:

- Refer [MCF8329HS EVM](#)
- Refer [MCF8329HS GUI \(MOTORSTUDIO\)](#)

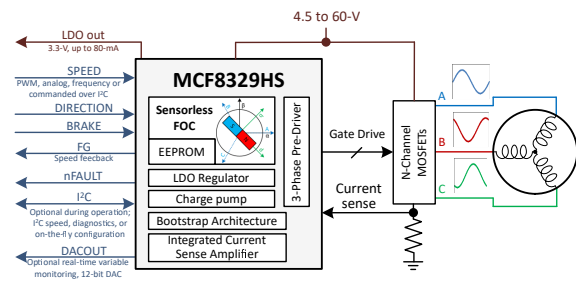

Simplified Schematic



Table of Contents

1 Features	1	8.2 Fault_Configuration Registers.....	117
2 Applications	1	8.3 Hardware_Configuration Registers.....	124
3 Description	1	8.4 Internal_Algorithm_Configuration Registers.....	134
4 Device Comparison	3	9 RAM (Volatile) Register Map	139
5 Pin Configuration and Functions	4	9.1 Fault_Status Registers.....	140
6 Specifications	7	9.2 System_Status Registers.....	144
6.1 Absolute Maximum Ratings.....	7	9.3 Algorithm_Control Registers.....	147
6.2 ESD Ratings Comm.....	7	9.4 Device_Control Registers.....	153
6.3 Recommended Operating Conditions.....	8	9.5 Algorithm_Variables Registers.....	155
6.4 Thermal Information.....	8	10 Application and Implementation	172
6.5 Electrical Characteristics.....	9	10.1 Application Information.....	172
6.6 Characteristics of the SDA and SCL bus for Standard and Fast mode.....	17	10.2 Typical Applications.....	172
6.7 Typical Characteristics.....	19	10.3 UL Recognized Component: MCF8329HSULIREER.....	178
7 Detailed Description	20	10.4 Power Supply Recommendations.....	179
7.1 Overview.....	20	10.5 Layout.....	180
7.2 Functional Block Diagram.....	21	11 Device and Documentation Support	184
7.3 Feature Description.....	22	11.1 Documentation Support.....	184
7.4 Device Functional Modes.....	82	11.2 Support Resources.....	184
7.5 External Interface.....	83	11.3 Trademarks.....	184
7.6 EEPROM access and I ² C interface.....	88	11.4 Electrostatic Discharge Caution.....	184
8 EEPROM (Non-Volatile) Register Map	95	11.5 Glossary.....	184
8.1 Algorithm_Configuration Registers.....	96	12 Revision History	184

4 Device Comparison

MCF8329HSULIREER is the UL recognized component while MCF8329HSIREER is the non-UL component. The differences between the two components are as listed below,

Table 4-1. Differences between MCF8329HSULIREER and MCF8329HSIREER

Feature	MCF8329HSULIREER	MCF8329HSIREER
Self Test Library (STL)	Available	Not Available
STL run command by user	Available in Section 9.4.1 as STL_CMD and STL_KEY bit fields	Not Applicable
Self Test Fault Status Reporting	Available in Section 9.1.2 as BOOT_STL_FAULT, CPU_RESET_FAULT_STATUS and WWDT_FAULT_STATUS bits	Not Applicable

5 Pin Configuration and Functions

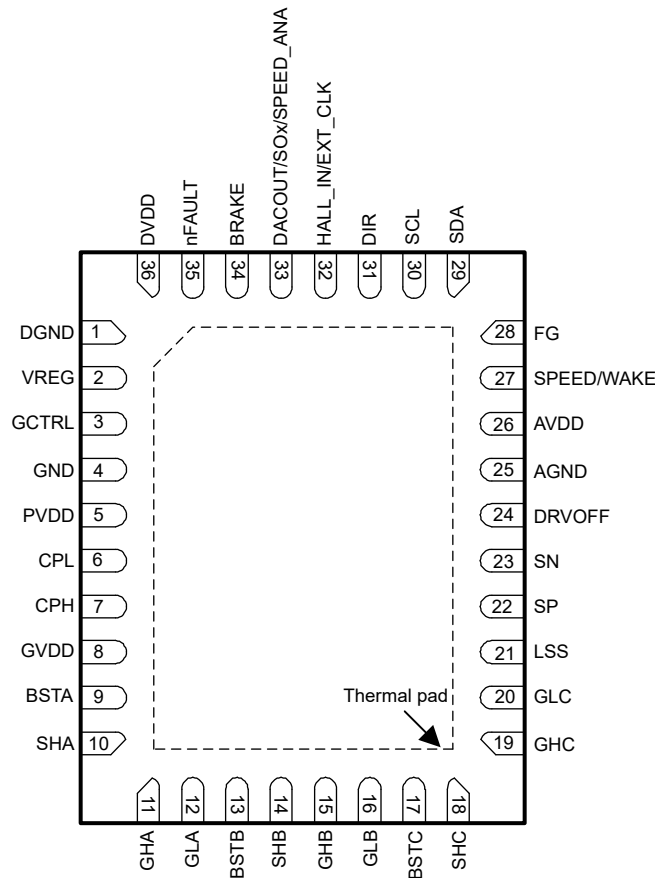

Figure 5-1. MCF8329HS 36-Pin WQFN With Exposed Thermal Pad Top View

Table 5-1. Pin Functions

PIN NAME	36-pin Package MCF8329HS	TYPE ⁽¹⁾	DESCRIPTION
AGND	25	GND	Device analog ground
AVDD	26	PWR	3.3 or 5V regulator output. Connect a X7R, 1µF or 2.2µF, 10V ceramic capacitor between the AVDD and AGND pins. This regulator can source up to 50mA for external circuits. AVDD capacitor should have an effective capacitance between 0.5µF and 2.8µF after operating voltage (AVDD) and temperature derating.
BRAKE	34	I	High → brake the motor Low → normal operation Connect to GND via 10kΩ resistor, if not used
BSTA	9	O	Bootstrap output pin. Connect a X7R, 1µF, 25V ceramic capacitor between BSTA and SHA.
BSTB	13	O	Bootstrap output pin. Connect a X7R, 1µF, 25V ceramic capacitor between BSTB and SHB.
BSTC	17	O	Bootstrap output pin. Connect a X7R, 1µF, 25V ceramic capacitor between BSTC and SHC.
CPH	7	PWR	Charge pump switching node. Connect a X7R, PVDD-rated ceramic capacitor between the CPH and CPL pins. TI recommends a capacitor voltage rating at least twice the normal operating voltage of the pin.
CPL	6	PWR	
DACOUT/S Ox/ SPEED_AN A	33	I/O	Multipurpose pin. Configurable as DAC output, current sense amplifier output or analog reference (speed or power or voltage) input.

Table 5-1. Pin Functions (continued)

PIN NAME	36-pin Package MCF8329HS	TYPE ⁽¹⁾	DESCRIPTION
DGND	1	GND	Device digital ground
DIR	31	I	Direction of motor spinning; When low, phase driving sequence is OUT A → OUT C → OUT B When high, phase driving sequence is OUT A → OUT B → OUT C Connect to AGND if not used
DRVOFF	24	I	Independent driver shutdown path. Pulling DRVOFF high turns off all external MOSFETs by putting the gate drivers into the pull-down state. This signal bypasses and overrides the digital and control core.
DVDD	36	PWR	1.5V internal regulator output. Connect a X7R, 1μF, 10V ceramic capacitor between the DVDD and DGND pins.
EXT_CLK/ HALL_IN	32	I	Multi-purpose pin. External clock reference input in external clock reference mode or single (3.3V or 5V) digital hall latch (optional) input for redundancy in motor lock detection.
FG	28	O	Motor speed indicator: open-drain output that requires a pull-up resistor to 1.8 to 5V. An optional internal pull-up resistor to AVDD can be enabled by setting PULLUP_ENABLE to 1b; no external pull-up resistor should be used when internal pull-up resistor is enabled.
GCTRL	3	O	Gate control for external MOSFET used as regulator to supply current to digital subsystem through VREG pin. This functionality helps to reduce power dissipation inside the device.
GHA	11	O	High-side gate driver output. Connect to the gate of the high-side power MOSFET
GHB	15	O	High-side gate driver output. Connect to the gate of the high-side power MOSFET
GHC	19	O	High-side gate driver output. Connect to the gate of the high-side power MOSFET
GLA	12	O	Low-side gate driver output. Connect to the gate of the low-side power MOSFET
GLB	16	O	Low-side gate driver output. Connect to the gate of the low-side power MOSFET
GLC	20	O	Low-side gate driver output. Connect to the gate of the low-side power MOSFET
GND	4	GND	Device power ground
GVDD	8	PWR	Gate driver power supply output. Connect a X7R, 30V rated ceramic ≥ 10μF local capacitance between the GVDD and GND pins. TI recommends a capacitor value of >10x C _{BSTx} and voltage rating at least twice the normal operating voltage of the pin.
LSS	21	PWR	Low side source pin, connect all sources of the external low-side MOSFETs here. This pin is the sink path for the low-side gate driver, and serves as an input to monitor the low-side MOSFET VDS voltage and VSEN_OCP voltage.
nFAULT	35	O	Fault indicator. Pulled logic-low during fault condition; open-drain output that requires a pull-up resistor to 1.8V to 5V. An optional internal pull-up resistor to AVDD is enabled by setting PULLUP_ENABLE to 1b; no external pull-up resistor should be used when internal pull-up resistor is enabled.
PVDD	5	PWR	Gate driver power supply input. Connect to the bridge power supply. Connect a X7R, 0.1μF, >2x PVDD-rated ceramic and >10μF local capacitance between the PVDD and GND pins. TI recommends a capacitor voltage rating at least twice the normal operating voltage of the pin.
SCL	30	I	I ² C clock input
SDA	29	I/O	I ² C data line
SHA	10	I/O	High-side source pin. Connect to the high-side power MOSFET source. This pin is an input for the VDS monitor and the output for the high-side gate driver sink.
SHB	14	I/O	High-side source pin. Connect to the high-side power MOSFET source. This pin is an input for the VDS monitor and the output for the high-side gate driver sink.
SHC	18	I/O	High-side source pin. Connect to the high-side power MOSFET source. This pin is an input for the VDS monitor and the output for the high-side gate driver sink.
SN	23	I	Current sense amplifier input. Connect to the low-side of the current shunt resistor.
SP	22	I	Low-side current shunt amplifier input. Connect to the low-side power MOSFET source and high-side of the current shunt resistor.

Table 5-1. Pin Functions (continued)

PIN	36-pin Package	TYPE ⁽¹⁾	DESCRIPTION
NAME	MCF8329HS		
SPEED/ WAKE	27	I	Multifunction input. Device sleep/wake input. Device speed input; supports analog, PWM or frequency based reference (speed or power or voltage) input.
VREG	2	PWR	Voltage regulator input supply for internal DVDD LDO. Connect to AVDD or external 3V-5.5V. Connect a X7R, 1µF, 10V ceramic capacitor between the VREG and DGND pins.
Thermal pad	-	PWR	Must be connected to ground

(1) I = input, O = output, GND = ground pin, PWR = power, NC = no connect

6 Specifications

6.1 Absolute Maximum Ratings

over operating temperature range (unless otherwise noted)⁽¹⁾

		MIN	MAX	UNIT
Power supply pin voltage	PVDD	-0.3	65	V
Bootstrap pin voltage	BSTx	-0.3	80	V
Bootstrap pin voltage	BSTx with respect to SHx	-0.3	20	V
Bootstrap pin voltage	BSTx with respect to GHx	-0.3	20	V
Charge pump pin voltage	CPL, CPH	-0.3	V _{GVDD}	V
Voltage difference between ground pins	GND, DGND, AGND	-0.3	0.3	V
Voltage regulator pin voltage (VREG)	VREG	-0.3	6	V
Gate control pin voltage (GCTRL)	GCTRL	-0.3	7	V
Gate driver regulator pin voltage	GVDD	-0.3	20	V
Digital regulator pin voltage	DVDD	-0.3	1.7	V
Analog regulator pin voltage	AVDD	-0.3	6	V
Logic pin voltage	DRVOFF, BRAKE, DIR, EXT_CLK, HALL_IN, SCL, SDA, SPEED/WAKE, DACOUT/SOx/SPEED_ANA	-0.3	6	V
Open drain pin output voltage	nFAULT, FG	-0.3	6	V
High-side gate drive pin voltage	GHx	-8	80	V
Transient 500ns high-side gate drive pin voltage	GHx	-10	80	V
High-side gate drive pin voltage	GHx with respect to SHx	-0.3	20	V
High-side source pin voltage	SHx	-8	70	V
Transient 500ns high-side source pin voltage	SHx	-10	72	V
Low-side gate drive pin voltage	GLx with respect to LSS	-0.3	20	V
Transient 500ns low-side gate drive pin voltage ⁽²⁾	GLx with respect to LSS	-1	20	V
Low-side gate drive pin voltage	GLx with respect to GVDD		0.3	V
Transient 500ns low-side gate drive pin voltage	GLx with respect to GVDD		1	V
Low-side source sense pin voltage	LSS	-1	1	V
Transient 500ns low-side source sense pin voltage	LSS	-10	8	V
Gate drive current	GHx, GLx	Internally Limited	Internally Limited	A
Shunt amplifier input pin voltage	SN, SP	-1	1	V
Transient 500ns shunt amplifier input pin voltage	SN, SP	-10	8	V
Ambient temperature, T _A		-40	125	°C
Junction temperature, T _J		-40	150	°C
Storage temperature, T _{stg}		-65	150	°C

- (1) Operation outside the Absolute Maximum Ratings may cause permanent device damage. Absolute Maximum Ratings do not imply functional operation of the device at these or any other conditions beyond those listed under Recommended Operating Conditions. If used outside the Recommended Operating Conditions but within the Absolute Maximum Ratings, the device may not be fully functional, and this may affect device reliability, functionality, performance, and shorten the device lifetime
- (2) Supports upto 5A for 500nS when GLx-LSS is negative

6.2 ESD Ratings Comm

			VALUE	UNIT
V _(ESD)	Electrostatic discharge	Human body model (HBM), per ANSI/ESDA/JEDEC JS-001 ⁽¹⁾	±2000	V
		Charged device model (CDM), per JEDEC specification JESD22C101 ⁽²⁾	±750	

- (1) JEDEC document JEP155 states that 500V HBM allows safe manufacturing with a standard ESD control process.

(2) JEDEC document JEP157 states that 250V CDM allows safe manufacturing with a standard ESD control process.

6.3 Recommended Operating Conditions

over operating temperature range (unless otherwise noted)

			MIN	NOM	MAX	UNIT
V _{PVDD}	Power supply voltage	PVDD	4.5		60	V
V _{PVDD_RAMP}	Power supply voltage ramp rate at power up	PVDD			30	V/μs
V _{BST}	Bootstrap pin voltage with respect to SHx	SPEED/WAKE = High, Outputs are switching	4		20	V
I _{AVDD} (1)	Regulator external load current (AVDD connected to VREG)	AVDD			50	mA
I _{TRICKLE}	Trickle charge pump external load current	BSTx			2	μA
V _{VREG}	VREG pin voltage	VREG	2.2		5.5	V
V _{IN}	Logic input voltage	DRVOFF, BRAKE, DIR, EXT_CLK, HALL_IN, SCL, SDA, SPEED/WAKE, DACOUT/SOx/SPEED_ANA	0		5.5	V
f _{PWM}	PWM frequency		0		80	kHz
V _{OD}	Open drain pullup voltage	FG, nFAULT			5.5	V
I _{OD}	Open drain output current	nFAULT			-10	mA
I _{GS} (1)	Total average gate-drive current (Low Side and High Side Combined)	I _{GHx} , I _{GLx}			30	mA
V _{SHSL}	Slew Rate on SHx pins				4	V/ns
C _{BOOT}	Capacitor between BSTx and SHx				4.7(2)	μF
C _{GVDD}	Capacitor between GVDD and GND				130	μF
T _A	Operating ambient temperature		-40		125	°C
T _J	Operating junction temperature		-40		150	°C

(1) Power dissipation and thermal limits must be observed

(2) Current flowing through boot diode (DBOOT) needs to be limited for C_{BSTx} > 4.7μF.

6.4 Thermal Information

THERMAL METRIC ⁽¹⁾		MCF8329HS	UNIT
		REE (WQFN)	
		36 pins	
R _{θJA}	Junction-to-ambient thermal resistance		°C/W
R _{θJC(top)}	Junction-to-case (top) thermal resistance		°C/W
R _{θJB}	Junction-to-board thermal resistance		°C/W
Ψ _{JT}	Junction-to-top characterization parameter		°C/W
Ψ _{JB}	Junction-to-board characterization parameter		°C/W
R _{θJC(bot)}	Junction-to-case (bottom) thermal resistance		°C/W

(1) For more information about traditional and new thermal metrics, see the [Semiconductor and IC Package Thermal Metrics](#) application report.

6.5 Electrical Characteristics

4.5V ≤ V_{PVDD} ≤ 60V, -40°C ≤ T_J ≤ 150°C (unless otherwise noted). Typical limits apply for T_A = 25°C, V_{PVDD} = 12V

PARAMETER		TEST CONDITIONS	MIN	TYP	MAX	UNIT
POWER SUPPLIES (PVDD, GVDD, AVDD, DVDD, VREG, GCTRL)						
I _{PVDDQ}	PVDD sleep mode current	V _{PVDD} = 12V, V _{SPEED/WAKE} = 0, T _A = 25°C, AVDD connected to VREG		3	5	μA
		V _{SPEED/WAKE} = 0, T _A = 125°C, AVDD connected to VREG		3.5	6	μA
I _{PVDDS}	PVDD standby mode current	V _{PVDD} = 12V, V _{SPEED/WAKE} < V _{EN_SB} , DRVOFF = LOW, T _A = 25°C, CLOCK_FREQUENCY = 0x0, AVDD connected to VREG		28	30	mA
		V _{SPEED/WAKE} < V _{EN_SB} , DRVOFF = LOW, CLOCK_FREQUENCY = 0x0, AVDD connected to VREG		28	30	mA
I _{PVDDS}	PVDD standby mode current	V _{PVDD} = 12V, V _{SPEED/WAKE} < V _{EN_SB} , DRVOFF = LOW, T _A = 25°C, CLOCK_FREQUENCY = 0x0, AVDD not connected to VREG, VREG = 3.3V external		10	12	mA
		V _{SPEED/WAKE} < V _{EN_SB} , DRVOFF = LOW, CLOCK_FREQUENCY = 0x0, AVDD not connected to VREG, VREG = 3.3V external		10	12	mA
I _{PVDDS}	PVDD standby mode current	V _{PVDD} = 12V, V _{SPEED/WAKE} < V _{EN_SB} , DRVOFF = LOW, T _A = 25°C, CLOCK_FREQUENCY = 0x1, AVDD connected to VREG		24	26	mA
		V _{SPEED/WAKE} < V _{EN_SB} , DRVOFF = LOW, CLOCK_FREQUENCY = 0x1, AVDD connected to VREG		24	26	mA
I _{PVDDS}	PVDD standby mode current	V _{PVDD} = 12V, V _{SPEED/WAKE} < V _{EN_SB} , DRVOFF = LOW, T _A = 25°C, CLOCK_FREQUENCY = 0x1, AVDD not connected to VREG, VREG = 3.3V external		10	12	mA
		V _{SPEED/WAKE} < V _{EN_SB} , DRVOFF = LOW, CLOCK_FREQUENCY = 0x1, AVDD not connected to VREG, VREG = 3.3V external		10	12	mA
I _{PVDDS}	PVDD standby mode current	V _{PVDD} = 12V, V _{SPEED/WAKE} < V _{EN_SB} , DRVOFF = LOW, T _A = 25°C, CLOCK_FREQUENCY = 0x2, AVDD connected to VREG		20	22	mA
		V _{SPEED/WAKE} < V _{EN_SB} , DRVOFF = LOW, CLOCK_FREQUENCY = 0x2, AVDD connected to VREG		20	22	mA
I _{PVDDS}	PVDD standby mode current	V _{PVDD} = 12V, V _{SPEED/WAKE} < V _{EN_SB} , DRVOFF = LOW, T _A = 25°C, CLOCK_FREQUENCY = 0x2, AVDD not connected to VREG, VREG = 3.3V external		10	12	mA
		V _{SPEED/WAKE} < V _{EN_SB} , DRVOFF = LOW, CLOCK_FREQUENCY = 0x2, AVDD not connected to VREG, VREG = 3.3V external		10	12	mA

6.5 Electrical Characteristics (continued)

4.5V ≤ V_{PVDD} ≤ 60V, −40°C ≤ T_J ≤ 150°C (unless otherwise noted). Typical limits apply for T_A = 25°C, V_{PVDD} = 12V

PARAMETER		TEST CONDITIONS	MIN	TYP	MAX	UNIT
I _{PVDD}	PVDD active mode current	V _{PVDD} = 12V, V _{SPEED/WAKE} > V _{EX_SL} , PWM_FREQ_OUT = 0011b (25kHz), T _J = 25°C, No FETs and motor connected, CLOCK_FREQUENCY = 0x0, AVDD connected to VREG		28	30	mA
		V _{SPEED/WAKE} > V _{EX_SL} , PWM_FREQ_OUT = 0011b (25kHz), No FETs and motor connected, CLOCK_FREQUENCY = 0x0, AVDD connected to VREG		28	30	mA
I _{PVDD}	PVDD active mode current	V _{PVDD} = 12V, V _{SPEED/WAKE} > V _{EX_SL} , PWM_FREQ_OUT = 0011b (25kHz), T _J = 25°C, No FETs and motor connected, CLOCK_FREQUENCY = 0x0, AVDD not connected to VREG, VREG = 3.3V external		10	12	mA
		V _{SPEED/WAKE} > V _{EX_SL} , PWM_FREQ_OUT = 0011b (25kHz), No FETs and motor connected, CLOCK_FREQUENCY = 0x0, AVDD not connected to VREG, VREG = 3.3V external		10	12	mA
I _{PVDD}	PVDD active mode current	V _{PVDD} = 12V, V _{SPEED/WAKE} > V _{EX_SL} , PWM_FREQ_OUT = 0011b (25kHz), T _J = 25°C, No FETs and motor connected, CLOCK_FREQUENCY = 0x1, AVDD connected to VREG		24	26	mA
		V _{SPEED/WAKE} > V _{EX_SL} , PWM_FREQ_OUT = 0011b (25kHz), No FETs and motor connected, CLOCK_FREQUENCY = 0x1, AVDD connected to VREG		24	26	mA
I _{PVDD}	PVDD active mode current	V _{PVDD} = 12V, V _{SPEED/WAKE} > V _{EX_SL} , PWM_FREQ_OUT = 0011b (25kHz), T _J = 25°C, No FETs and motor connected, CLOCK_FREQUENCY = 0x1, AVDD not connected to VREG, VREG = 3.3V external		10	12	mA
		V _{SPEED/WAKE} > V _{EX_SL} , PWM_FREQ_OUT = 0011b (25kHz), No FETs and motor connected, CLOCK_FREQUENCY = 0x1, AVDD not connected to VREG, VREG = 3.3V external		10	12	mA
I _{PVDD}	PVDD active mode current	V _{PVDD} = 12V, V _{SPEED/WAKE} > V _{EX_SL} , PWM_FREQ_OUT = 0011b (25kHz), T _J = 25°C, No FETs and motor connected, CLOCK_FREQUENCY = 0x2, AVDD connected to VREG		20	22	mA
		V _{SPEED/WAKE} > V _{EX_SL} , PWM_FREQ_OUT = 0011b (25kHz), No FETs and motor connected, CLOCK_FREQUENCY = 0x2, AVDD connected to VREG		20	22	mA

6.5 Electrical Characteristics (continued)

4.5V ≤ V_{PVDD} ≤ 60V, -40°C ≤ T_J ≤ 150°C (unless otherwise noted). Typical limits apply for T_A = 25°C, V_{PVDD} = 12V

PARAMETER		TEST CONDITIONS	MIN	TYP	MAX	UNIT
I _{PVDD}	PVDD active mode current	V _{PVDD} = 12V, V _{SPEED/WAKE} > V _{EX_SL} , PWM_FREQ_OUT = 0011b (25kHz), T _J = 25°C, No FETs and motor connected, CLOCK_FREQUENCY = 0x2, AVDD not connected to VREG, VREG = 3.3V external		10	12	mA
		V _{SPEED/WAKE} > V _{EX_SL} , PWM_FREQ_OUT = 0011b (25kHz), No FETs and motor connected, CLOCK_FREQUENCY = 0x2, AVDD not connected to VREG, VREG = 3.3V external		10	12	mA
I _{BSx}	Bootstrap pin leakage current	V _{BSTx} = V _{SHx} = 60V, V _{GVDD} = 0V, V _{SPEED/WAKE} = LOW	5	10	16	μA
I _{BS_TRAN}	Bootstrap pin active mode transient leakage current	GLx = GHx = Switching at 20kHz, No FETs connected	60	115	300	μA
V _{GVDD_RT}	GVDD Gate driver regulator voltage (Room Temperature)	V _{PVDD} ≥ 40V, I _{GS} = 10mA, T _J = 25°C	11.8	13	15	V
		22V ≤ V _{PVDD} ≤ 40V, I _{GS} = 30mA, T _J = 25°C	11.8	13	15	V
		8V ≤ V _{PVDD} ≤ 22V, I _{GS} = 30mA, T _J = 25°C	11.8	13	15	V
		6.75V ≤ V _{PVDD} ≤ 8V, I _{GS} = 10mA, T _J = 25°C	11.8	13	14.5	V
V _{GVDD}	GVDD Gate driver regulator voltage	V _{PVDD} ≥ 40V, I _{GS} = 10mA	11.5		15.5	V
		22V ≤ V _{PVDD} ≤ 40V, I _{GS} = 30mA	11.5		15.5	V
		8V ≤ V _{PVDD} ≤ 22V; I _{GS} = 30mA	11.5		15.5	V
		6.75V ≤ V _{PVDD} ≤ 8V, I _{GS} = 10mA	11.5		14.5	V
		4.5V ≤ V _{PVDD} ≤ 6.75V, I _{GS} = 10mA	2*V _{PVDD} - 1.4		13.5	V
V _{AVDD_RT}	AVDD Analog regulator voltage (Room Temperature), AVDD_VOL_SEL = 0b	V _{PVDD} ≥ 6V, 0mA ≤ I _{AVDD} ≤ 50mA, T _J = 25°C	3.2	3.3	3.34	V
		4.5 ≤ V _{PVDD} < 6V, 0mA ≤ I _{AVDD} ≤ 50mA, T _J = 25°C	3.13	3.3	3.46	V
V _{AVDD_RT}	AVDD Analog regulator voltage (Room Temperature), AVDD_VOL_SEL = 1b	V _{PVDD} ≥ 6V, 0mA ≤ I _{AVDD} ≤ 50mA, T _J = 25°C	4.85	5	5.15	V
V _{AVDD}	AVDD Analog regulator voltage, AVDD_VOL_SEL = 0b	V _{PVDD} ≥ 6V, 0mA ≤ I _{AVDD} ≤ 50mA	3.2	3.3	3.4	V
		4.5 ≤ V _{PVDD} < 6V, 0mA ≤ I _{AVDD} ≤ 50mA	3.125	3.3	3.5	V
V _{AVDD}	AVDD Analog regulator voltage, AVDD_VOL_SEL = 1b	V _{PVDD} ≥ 6V, 0mA ≤ I _{AVDD} ≤ 50mA	4.85	5	5.15	V
V _{DVDD}	Digital regulator voltage		1.52	1.62	1.7	V
GATE DRIVERS (GHx, GLx, SHx, SLx)						
V _{GSHx_LO}	High-side gate drive low level voltage	I _{GHx} = -100mA; V _{GVDD} = 12V; No FETs connected	0.05	0.11	0.24	V
V _{GSHx_HI}	High-side gate drive high level voltage (V _{BSTx} - V _{GHx})	I _{GHx} = 100mA; V _{GVDD} = 12V; No FETs connected	0.28	0.44	0.82	V
V _{GSLx_LO}	Low-side gate drive low level voltage	I _{GLx} = -100mA; V _{GVDD} = 12V; No FETs connected	0.05	0.11	0.27	V
V _{GSLx_HI}	Low-side gate drive high level voltage (V _{GVDD} - V _{GLx})	I _{GLx} = 100mA; V _{GVDD} = 12V; No FETs connected	0.28	0.44	0.82	V
R _{DS(ON)_PU_HS}	High-side pullup switch resistance	I _{GHx} = 100mA; V _{GVDD} = 12V	2.7	4.5	8.4	Ω

6.5 Electrical Characteristics (continued)

4.5V ≤ V_{PVDD} ≤ 60V, −40°C ≤ T_J ≤ 150°C (unless otherwise noted). Typical limits apply for T_A = 25°C, V_{PVDD} = 12V

PARAMETER		TEST CONDITIONS	MIN	TYP	MAX	UNIT
R _{DS(ON)_PD_HS}	High-side pulldown switch resistance	I _{GHx} = 100mA; V _{GVDD} = 12V	0.5	1.1	2.4	Ω
R _{DS(ON)_PU_LS}	Low-side pullup switch resistance	I _{GLx} = 100mA; V _{GVDD} = 12V	2.7	4.5	8.3	Ω
R _{DS(ON)_PD_LS}	Low-side pulldown switch resistance	I _{GLx} = 100mA; V _{GVDD} = 12V	0.5	1.1	2.8	Ω
I _{DRIVEP_HS}	High-side peak source gate current	V _{GSHx} = 12V	550	1000	1575	mA
I _{DRIVEN_HS}	High-side peak sink gate current	V _{GSHx} = 0V	1150	2000	2675	mA
I _{DRIVEP_LS}	Low-side peak source gate current	V _{GSLx} = 12V	550	1000	1575	mA
I _{DRIVEN_LS}	Low-side peak sink gate current	V _{GSLx} = 0V	1150	2000	2675	mA
R _{PD_LS}	Low-side passive pull down	GLx to LSS	80	100	120	kΩ
R _{PDSA_HS}	High-side semiactive pull down	GHx to SHx, V _{GSHx} = 2V	8	10	12.5	kΩ
BOOTSTRAP DIODES						
V _{BOOTD}	Bootstrap diode forward voltage	I _{BOOT} = 100 μA			0.8	V
		I _{BOOT} = 100 mA			1.6	V
R _{BOOTD}	Bootstrap dynamic resistance (ΔV _{BOOTD} /ΔI _{BOOT})	I _{BOOT} = 100 mA and 50mA	4.5	5.5	9	Ω
LOGIC-LEVEL INPUTS (SCL, SDA, SPEED/WAKE, BRAKE, DACOUT/SOx/SPEED_ANA, DIR, EXT_CLK)						
V _{IL}	Input logic low voltage	AVDD = 3.3V, 5V			0.25*AV _{DD}	V
V _{IH}	Input logic high voltage	AVDD = 3.3V, 5V			0.65*AV _{DD}	V
V _{HYS}	Input hysteresis		50	500	800	mV
I _{IL}	Input logic low current	AVDD = 3.3V, 5V	-0.15		0.15	μA
I _{IH}	Input logic high current	AVDD = 3.3V, 5V	-0.3		0.1	μA
R _{PD_SPEED}	Input pulldown resistance	SPEED/WAKE pin To GND	0.6	1	1.4	MΩ
LOGIC-LEVEL INPUTS (DRVOFF)						
V _{IL}	Input logic low voltage				0.8	V
V _{IH}	Input logic high voltage		2.2			V
V _{HYS}	Input hysteresis		200	400	650	mV
I _{IL}	Input logic low current	Pin Voltage = 0V	-1	0	1	μA
I _{IH}	Input logic high current	Pin Voltage = 5V	7	20	35	μA
R _{PD_DRVOFF}	Input pulldown resistance	DRVOFF To GND	100	200	300	kΩ
OPEN-DRAIN OUTPUTS (nFAULT, FG)						
V _{OL}	Output logic low voltage	I _{OD} = -5mA			0.4	V
I _{OZ}	Output logic high current	V _{OD} = 3.3V	0		0.5	μA
SPEED INPUT - ANALOG MODE						
V _{ANA_FS}	Analog full-speed voltage		2.95	3	3.05	V
V _{ANA_RES}	Analog voltage resolution			732		μV
SPEED INPUT - PWM MODE						
f _{PWM}	PWM input frequency		0.01		100	kHz

6.5 Electrical Characteristics (continued)

$4.5V \leq V_{PVDD} \leq 60V$, $-40^{\circ}C \leq T_J \leq 150^{\circ}C$ (unless otherwise noted). Typical limits apply for $T_A = 25^{\circ}C$, $V_{PVDD} = 12V$

PARAMETER		TEST CONDITIONS	MIN	TYP	MAX	UNIT
Res _{PWM}	PWM input resolution	f _{PWM} = 0.01 to 0.35kHz	11	12	13	bits
		f _{PWM} = 0.35 to 2kHz	12	13	14	bits
		f _{PWM} = 2 to 3.5kHz	11	11.5	12	bits
		f _{PWM} = 3.5 to 7kHz	13	13.5	14	bits
		f _{PWM} = 7 to 14kHz	12	12.5	13	bits
		f _{PWM} = 14 to 29.2kHz	11	11.5	12	bits
		f _{PWM} = 29.3 to 60kHz	10	10.5	11	bits
		f _{PWM} = 60 to 95kHz	8	9	10	bits
SPEED INPUT - FREQUENCY MODE						
f _{PWM_FREQ}	PWM input frequency range	Duty cycle = 50%	3		32767	Hz
SLEEP MODE						
V _{EN_SL}	Analog voltage to enter sleep mode	SPEED_MODE = 00b (analog mode)			40	mV
V _{EX_SL}	Analog voltage to exit sleep mode		2.6			V
t _{DET_ANA}	Time needed to detect wake up signal on SPEED/WAKE pin	SPEED_MODE = 00b (analog mode), V _{SPEED/WAKE} > V _{EX_SL}	0.5	1	1.5	μs
t _{WAKE}	Wakeup time from sleep mode	V _{SPEED/WAKE} > V _{EX_SL} to DVDD voltage available, SPEED_MODE = 00b (analog mode)		3	5	ms
t _{EX_SL_DR_ANA}	Time taken to drive motor after exiting from sleep mode	SPEED_MODE = 00b (analog mode) V _{SPEED/WAKE} > V _{EX_SL} , ISD detection disabled			30	ms
t _{DET_PWM}	Time needed to detect wake up signal on SPEED pin	SPEED_MODE = 01b (PWM mode) or 11b (Frequency mode), V _{SPEED/WAKE} > V _{IH}	0.5	1	1.5	μs
t _{WAKE_PWM}	Wakeup time from sleep mode	V _{SPEED/WAKE} > V _{IH} to DVDD voltage available and release nFault, SPEED_MODE = 01b (PWM mode) or 11b (Frequency mode)		3	5	ms
t _{EX_SL_DR_PWM}	Time taken to drive motor after wakeup from sleep state	SPEED_MODE = 01b (PWM mode) V _{SPEED/WAKE} > V _{IH} , ISD detection disabled			30	ms
t _{DET_SL_ANA}	Time needed to detect sleep command	SPEED_MODE = 00b (analog mode) V _{SPEED/WAKE} < V _{EN_SL} , SLEEP_ENTRY_TIME = 00b or 01b	0.5	1	2	ms

6.5 Electrical Characteristics (continued)

4.5V ≤ V_{PVDD} ≤ 60V, −40°C ≤ T_J ≤ 150°C (unless otherwise noted). Typical limits apply for T_A = 25°C, V_{PVDD} = 12V

PARAMETER		TEST CONDITIONS	MIN	TYP	MAX	UNIT
t _{DET_SL_PWM}	Time needed to detect sleep command	SPEED_MODE = 01b (PWM mode) or 11b (Frequency mode), V _{SPEED/WAKE} < V _{IL} (PWM mode and Frequency mode), SLEEP_ENTRY_TIME = 00b	0.035	0.05	0.065	ms
		SPEED_MODE = 01b (PWM mode), or 11b (Frequency mode), V _{SPEED/WAKE} < V _{IL} (PWM mode and Frequency mode), SLEEP_ENTRY_TIME = 01b	0.14	0.2	0.26	ms
		SPEED_MODE = 01b (PWM mode) or 11b (Frequency mode) or 00b (analog mode), V _{SPEED/WAKE} < V _{IL} (PWM mode and Frequency mode), V _{SPEED/WAKE} < V _{EN_SL} (analog mode), SLEEP_ENTRY_TIME = 10b	14	20	26	ms
		SPEED_MODE = 01b (PWM mode) or 11b (Frequency mode) or 00b (analog mode), V _{SPEED/WAKE} < V _{IL} (PWM mode and Frequency mode), V _{SPEED/WAKE} < V _{EN_SL} (analog mode), SLEEP_ENTRY_TIME = 11b	140	200	260	ms
t _{EN_SL}	Time needed to stop driving motor after detecting sleep command	V _{SPEED/WAKE} < V _{EN_SL} (analog mode) or V _{SPEED/WAKE} < V _{IL} (PWM and frequency mode)		1	2	ms
STANDBY MODE						
t _{EX_SB_DR_A} NA	Time taken to drive motor after exiting standby mode	SPEED_MODE = 00b (analog mode) V _{SPEED} > V _{EN_SB} , ISD detection disabled			6	ms
t _{EX_SB_DR_P} WM	Time taken to drive motor after exiting standby mode	SPEED_MODE = 01b (PWM mode) V _{SPEED} > V _{IH} , ISD detection disabled			6	ms
t _{DET_SB_ANA}	Time needed to detect standby mode	SPEED_MODE = 00b (analog mode) V _{SPEED} < V _{EN_SB}	0.5	1	2	ms
t _{EN_SB_PWM}	Time needed to detect standby command	SPEED_MODE = 01b (PWM mode) or 11b (Frequency mode), V _{SPEED} < V _{IL} , SLEEP_ENTRY_TIME = 00b	0.035	0.05	0.065	ms
		SPEED_MODE = 01b (PWM mode) or 11b (Frequency mode), V _{SPEED} < V _{IL} , SLEEP_ENTRY_TIME = 01b	0.14	0.2	0.26	ms
		SPEED_MODE = 01b (PWM mode) or 11b (Frequency mode), V _{SPEED} < V _{IL} , SLEEP_ENTRY_TIME = 10b	14	20	26	ms
		SPEED_MODE = 01b (PWM mode) or 11b (Frequency mode), V _{SPEED} < V _{IL} , SLEEP_ENTRY_TIME = 11b	140	200	260	ms
t _{EN_SB_DIG}	Time needed to detect standby mode	SPEED_MODE = 10b (I2C mode), SPEED_CMD = 0		1	2	ms
t _{EN_SB}	Time needed to stop driving motor after detecting standby command	V _{SPEED} < V _{EN_SL} (analog mode) or V _{SPEED} < V _{IL} (PWM mode) or SPEED command = 0 (I2C mode)		1	2	ms
OSCILLATOR						

6.5 Electrical Characteristics (continued)

4.5V ≤ V_{PVDD} ≤ 60V, −40°C ≤ T_J ≤ 150°C (unless otherwise noted). Typical limits apply for T_A = 25°C, V_{PVDD} = 12V

PARAMETER		TEST CONDITIONS	MIN	TYP	MAX	UNIT
f _{OSCREF}	External clock reference	EXT_CLK_CONFIG = 000b		8		kHz
		EXT_CLK_CONFIG = 001b		16		kHz
		EXT_CLK_CONFIG = 010b		32		kHz
		EXT_CLK_CONFIG = 011b		64		kHz
		EXT_CLK_CONFIG = 100b		128		kHz
		EXT_CLK_CONFIG = 101b		256		kHz
		EXT_CLK_CONFIG = 110b		512		kHz
		EXT_CLK_CONFIG = 111b		1024		kHz
PROTECTION CIRCUITS						
V _{AVDD_UVLO}	Regulator undervoltage lockout (AVDD-UVLO)	Supply rising	2.6	2.7	2.8	V
		Supply falling	2.6	2.7	2.8	V
V _{AVDD_UVLO_HYS}	Regulator UVLO hysteresis	Rising to falling threshold	150	190	240	mV
t _{AVDD_UVLO_DEG}	Regulator UVLO deglitch time			5		µs
V _{DVDD_UVLO}	Digital regulator undervoltage lockout (DVDD-UVLO)	Supply rising	1.2	1.28	1.32	V
V _{DVDD_UVLO}	Digital regulator undervoltage lockout (DVDD-UVLO)	Supply falling	1.18	1.23	1.3	V
V _{PVDD_UV}	PVDD undervoltage lockout threshold	V _{PVDD} rising	4.3	4.4	4.5	V
		V _{PVDD} falling	4	4.1	4.25	
V _{PVDD_UV_HYS}	PVDD undervoltage lockout hysteresis	Rising to falling threshold	225	265	325	mV
t _{PVDD_UV_DG}	PVDD undervoltage deglitch time		10	20	30	µs
V _{AVDD_POR}	AVDD supply POR threshold	AVDD rising	2.7	2.85	3.0	V
		AVDD falling	2.5	2.65	2.8	
V _{AVDD_POR_HYS}	AVDD POR hysteresis	Rising to falling threshold	170	200	250	mV
t _{AVDD_POR_DG}	AVDD POR deglitch time		7	12	22	µs
V _{GVDD_UV}	GVDD undervoltage threshold	V _{GVDD} rising	7.3	7.5	7.8	V
		V _{GVDD} falling	6.4	6.7	6.9	V
V _{GVDD_UV_HYS}	GVDD undervoltage hysteresis	Rising to falling threshold	800	900	1000	mV
t _{GVDD_UV_DG}	GVDD undervoltage deglitch time		5	10	15	µs
V _{BST_UV}	Bootstrap undervoltage threshold	V _{BSTx} - V _{SHx} ; V _{BSTx} rising	3.9	4.45	5	V
		V _{BSTx} - V _{SHx} ; V _{BSTx} falling	3.7	4.2	4.8	V
V _{BST_UV_HYS}	Bootstrap undervoltage hysteresis	Rising to falling threshold	150	220	285	mV
t _{BST_UV_DG}	Bootstrap undervoltage deglitch time		2	4	6	µs

6.5 Electrical Characteristics (continued)

4.5V ≤ V_{PVDD} ≤ 60V, -40°C ≤ T_J ≤ 150°C (unless otherwise noted). Typical limits apply for T_A = 25°C, V_{PVDD} = 12V

PARAMETER		TEST CONDITIONS	MIN	TYP	MAX	UNIT
V _{DS_LVL}	V _{DS} overcurrent protection threshold Reference	SEL_VDS_LVL = 0000	0.04	0.06	0.08	V
		SEL_VDS_LVL = 0001	0.09	0.12	0.15	V
		SEL_VDS_LVL = 0010	0.14	0.18	0.23	V
		SEL_VDS_LVL = 0011	0.19	0.24	0.29	V
		SEL_VDS_LVL = 0100	0.23	0.3	0.37	V
		SEL_VDS_LVL = 0101	0.3	0.36	0.43	V
		SEL_VDS_LVL = 0110	0.35	0.42	0.5	V
		SEL_VDS_LVL = 0111	0.4	0.48	0.56	V
		SEL_VDS_LVL = 1000	0.5	0.6	0.7	V
		SEL_VDS_LVL = 1001	0.65	0.8	0.9	V
		SEL_VDS_LVL = 1010	0.85	1	1.15	V
		SEL_VDS_LVL = 1011	1	1.2	1.34	V
		SEL_VDS_LVL = 1100	1.2	1.4	1.58	V
		SEL_VDS_LVL = 1101	1.4	1.6	1.78	V
SEL_VDS_LVL = 1110	1.6	1.8	2	V		
SEL_VDS_LVL = 1111	1.7	2	2.2	V		
V _{SENSE_LVL}	V _{SENSE} overcurrent protection threshold	LSS to GND pin = 0.5V	0.48	0.5	0.52	V
t _{DS_BLK}	V _{DS} overcurrent protection blanking time		0.5	1	2.7	μs
t _{DS_DG}	V _{DS} and V _{SENSE} overcurrent protection deglitch time		1.5	3	5	μs
t _{SD_SINK_DIG}	DRVOFF peak sink current duration		3	5	7	μs
t _{SD_DIG}	DRVOFF digital shutdown delay		0.5	1.5	2.2	μs
t _{SD}	DRVOFF analog shutdown delay		7	14	21	μs
T _{OTSD}	Thermal shutdown temperature	T _J rising	160	170	187	°C
T _{HYS}	Thermal shutdown hysteresis		16	20	23	°C
I²C Serial Interface						
V _{I2C_L}	LOW-level input voltage		-0.5	0.3*AVD D		V
V _{I2C_H}	HIGH-level input voltage		0.7*AVD D		5.5	V
V _{I2C_HYS}	Hysteresis		0.05*AV DD			V
V _{I2C_OL}	LOW-level output voltage	open-drain at 2mA sink current	0		0.4	V
I _{I2C_OL}	LOW-level output current	V _{I2C_OL} = 0.6V			6	mA
I _{I2C_IL}	Input current on SDA and SCL		-10 ⁽¹⁾		10 ⁽¹⁾	μA
C _i	Capacitance for SDA and SCL				10	pF
t _{of}	Output fall time from V _{I2C_H} (min) to V _{I2C_L} (max)	Standard Mode			250 ⁽²⁾	ns
		Fast Mode			250 ⁽²⁾	ns
t _{SP}	Pulse width of spikes that must be suppressed by the input filter	Fast Mode	0		50 ⁽³⁾	ns
EEPROM						
EE _{Prog}	Programming voltage		1.35	1.5	1.65	V
EE _{RET}	Retention	T _A = 25 °C		100		Years
		T _J = -40 to 150 °C	10			Years

6.5 Electrical Characteristics (continued)

$4.5V \leq V_{PVDD} \leq 60V$, $-40^{\circ}C \leq T_J \leq 150^{\circ}C$ (unless otherwise noted). Typical limits apply for $T_A = 25^{\circ}C$, $V_{PVDD} = 12V$

PARAMETER		TEST CONDITIONS	MIN	TYP	MAX	UNIT
EE _{END}	Endurance	$T_J = -40$ to $150^{\circ}C$	1000			Cycles
		$T_J = -40$ to $85^{\circ}C$	20000			Cycles

- (1) If AVDD is switched off, I/O pins must not obstruct the SDA and SCL lines.
- (2) The maximum tf for the SDA and SCL bus lines (300ns) is longer than the specified maximum tof for the output stages (250ns). This allows series protection resistors (Rs) to be connected between the SDA/SCL pins and the SDA/SCL bus lines without exceeding the maximum specified tf.
- (3) Input filters on the SDA and SCL inputs suppress noise spikes of less than 50ns

6.6 Characteristics of the SDA and SCL bus for Standard and Fast mode

over operating free-air temperature range (unless otherwise noted)

PARAMETER		TEST CONDITIONS	MIN	NOM	MAX	UNIT
Standard-mode						
f _{SCL}	SCL clock frequency		0		100	kHz
t _{HD_STA}	Hold time (repeated) START condition	After this period, the first clock pulse is generated	4			μs
t _{LOW}	LOW period of the SCL clock		4.7			μs
t _{HIGH}	HIGH period of the SCL clock		4			μs
t _{SU_STA}	Set-up time for a repeated START condition		4.7			μs
t _{HD_DAT}	Data hold time ⁽¹⁾	I2C bus devices	0 ⁽²⁾		⁽³⁾	μs
t _{SU_DAT}	Data set-up time		250			ns
t _r	Rise time for both SDA and SCL signals				1000	ns
t _f	Fall time of both SDA and SCL signals ⁽²⁾ ^{(5) (6) (7)}				300	ns
t _{SU_STO}	Set-up time for STOP condition		4			μs
t _{BUF}	Bus free time between STOP and START condition		4.7			μs
C _b	Capacitive load for each bus line ⁽⁸⁾				400	pF
t _{VD_DAT}	Data valid time ⁽⁹⁾				3.45 ⁽³⁾	μs
t _{VD_ACK}	Data valid acknowledge time ⁽¹⁰⁾				3.45 ⁽³⁾	μs
V _{nL}	Noise margin at the LOW level	For each connected device (including hysteresis)	0.1*AVD D			V
V _{nh}	Noise margin at the HIGH level	For each connected device (including hysteresis)	0.2*AVD D			V
Fast-mode						
f _{SCL}	SCL clock frequency		0		400	KHz
t _{HD_STA}	Hold time (repeated) START condition	After this period, the first clock pulse is generated	0.6			μs
t _{LOW}	LOW period of the SCL clock		1.3			μs
t _{HIGH}	HIGH period of the SCL clock		0.6			μs
t _{SU_STA}	Set-up time for a repeated START condition		0.6			μs
t _{HD_DAT}	Data hold time ⁽¹⁾		0 ⁽²⁾		⁽³⁾	μs
t _{SU_DAT}	Data set-up time		100 ⁽⁴⁾			ns
t _r	Rise time for both SDA and SCL signals		20		300	ns
t _f	Fall time of both SDA and SCL signals ⁽²⁾ ^{(5) (6) (7)}		20x (AVDD/ 5.5V)		300	ns

over operating free-air temperature range (unless otherwise noted)

PARAMETER		TEST CONDITIONS	MIN	NOM	MAX	UNIT
t_{SU_STO}	Set-up time for STOP condition		0.6			μ s
t_{BUF}	Bus free time between STOP and START condition		1.3			μ s
C_b	Capacitive load for each bus line ⁽⁸⁾				400	pF
t_{VD_DAT}	Data valid time ⁽⁹⁾				0.9 ⁽³⁾	μ s
t_{VD_ACK}	Data valid acknowledge time ⁽¹⁰⁾				0.9 ⁽³⁾	μ s
V_{nL}	Noise margin at the LOW level	For each connected device (including hysteresis)	0.1*AVD D			V
V_{nh}	Noise margin at the HIGH level	For each connected device (including hysteresis)	0.2*AVD D			V

- (1) t_{HD_DAT} is the data hold time that is measured from the falling edge of SCL, applies to data in transmission and the acknowledge.
- (2) A device must internally provide a hold time of at least 300ns for the SDA signal (with respect to the $V_{IH(min)}$ of the SCL signal) to bridge the undefined region of the falling edge of SCL.
- (3) The maximum t_{HD_DAT} could be 3.45 μ s and .9 μ s for Standard-mode and Fast-mode, but must be less than the maximum of t_{VD_DAT} or t_{VD_ACK} by a transition time. This maximum must only be met if the device does not stretch the LOW period (t_{LOW}) of the SCL signal. If the clock stretched the SCL, the data must be valid by the set-up time before it releases the clock.
- (4) A Fast-mode I2C-bus device can be used in a Standard-mode I2C-bus system, but the requirement t_{SU_DAT} 250ns must then be met. This will automatically be the case if the device does not stretch the LOW period of the SCL signal. If such a device does stretch the LOW period of the SCL signal, it must output the next data bit to the SDA line $t_{r(max)} + t_{SU_DAT} = 1000 + 250 = 1250$ ns (according to the Standard-mode I2C-bus specification) before the SCL line is released. Also the acknowledge timing must meet this set-up time.
- (5) If mixed with HS-mode devices, faster fall times according to Table 10 are allowed.
- (6) The maximum t_f for the SDA and SCL bus lines is specified at 300ns. The maximum fall time for the SDA output stage t_f is specified at 250ns. This allows series protection resistors to be connected in between the SDA and the SCL pins and the SDA/SCL bus lines without exceeding the maximum specified t_f .
- (7) In Fast-mode Plus, fall time is specified the same for both output stage and bus timing. If series resistors are used, designers should allow for this when considering bus timing.
- (8) The maximum bus capacitance allowable may vary from the value depending on the actual operating voltage and frequency of the application.
- (9) t_{VD_DAT} = time for data signal from SCL LOW to SDA output (HIGH or LOW, depending on which one is worse).
- (10) t_{VD_ACK} = time for Acknowledgement signal from SCL LOW to SDA output (HIGH or LOW, depending on which one is worse).

6.7 Typical Characteristics

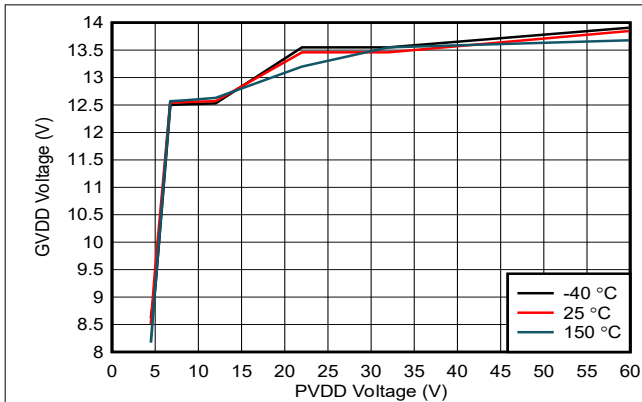

Figure 6-1. GVDD Voltage over PVDD Voltage

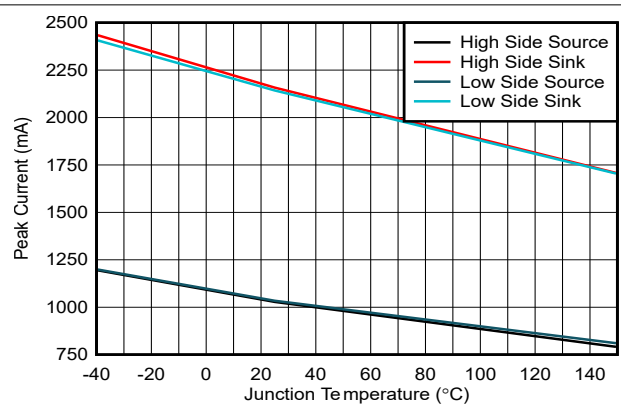

Figure 6-2. Driver Peak Current over Junction Temperature

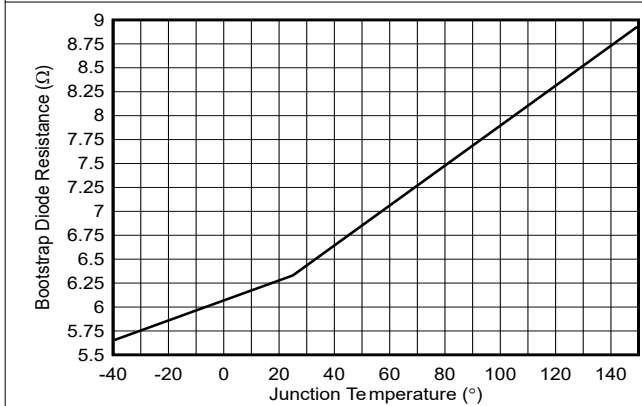

Figure 6-3. Bootstrap Diode Resistance over Junction Temperature

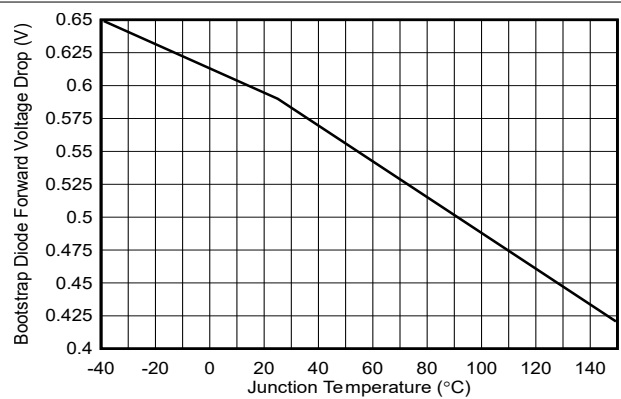

Figure 6-4. Bootstrap Diode Forward Voltage Drop over Junction Temperature

7 Detailed Description

7.1 Overview

The MCF8329HS provides a code-free sensorless FOC solution with an integrated three-phase gate driver for driving high-speed brushless-DC motors. Motor current is sensed using an integrated current sensing amplifier and one external sense resistor in a single shunt configuration. The device can operate from a single power supply and integrates an LDO that generates the necessary voltage rails for the device and can be used to power external circuits.

MCF8329HS implements single shunt sensorless FOC; therefore, an external microcontroller is not required to spin the brushless DC motor. The algorithm is implemented in a fixed-function state machine, so no coding is needed. The algorithm is highly configurable through register settings ranging from motor start-up behavior to closed-loop operation. Register settings can be stored in non-volatile EEPROM, which allows the device to operate stand-alone once it has been configured. The device receives a reference command through a PWM input, analog voltage, frequency input, or I²C command. The device can be configured to control motor speed (speed control) DC input power (power control) or the quadrature (q-) axis current (current control) or directly the voltage applied (v_q and v_d) to the motor (modulation index control or open loop voltage control).

In-built protection features include power-supply undervoltage lockout (PVDD_UVLO), regulator undervoltage lockout (GVDD_UV), bootstrap undervoltage lockout (BST_UV), VDS overcurrent protection (OCP), sense resistor overcurrent protection (SEN_OCP), motor lock detection and overtemperature shutdown (OTSD). Fault events are indicated by the nFAULT pin with detailed fault information available in the status registers.

A standard I²C provides a simple method for configuring the various device settings and reading fault diagnostic information through an external controller.

The MCF8329HS device is available in a 0.4mm pin pitch, WQFN surface-mount package. The WQFN package size is 5mm × 4mm with a height of 0.8mm.

7.2 Functional Block Diagram

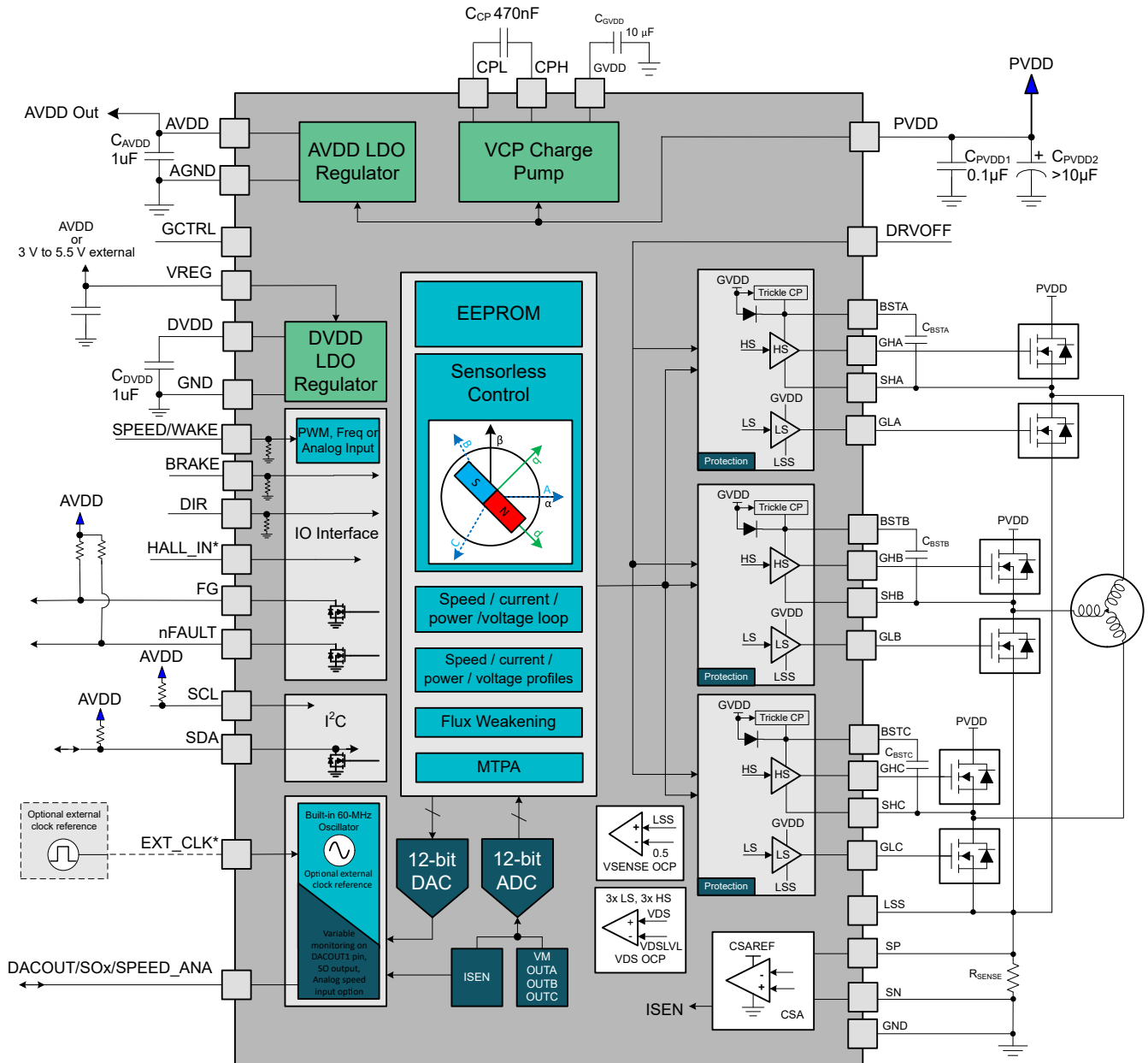

*HALL_IN and EXT_CLK are mux'ed functions on pin 32

Figure 7-1. MCF8329HS Functional Block Diagram

7.3 Feature Description

Table 7-1 lists the recommended values of the external components for the driver.

Table 7-1. MCF8329HS External Components

COMPONENTS	PIN 1	PIN 2	RECOMMENDED
C _{PVDD1}	PVDD	GND	X7R, 0.1μF, >2x PVDD-rated
C _{PVDD2}	PVDD	GND	≥ 10μF, >2x PVDD-rated
C _{CP}	CPH	CPL	X7R, 470nF, PVDD-rated
C _{AVDD}	AVDD	AGND	X7R, 1μF or 2.2μF, 10V
C _{GVDD}	GVDD	GND	X7R, ≥10uF, 30V
C _{DVDD}	DVDD	DGND	X7R, 1μF, 10V
C _{VREG}	VREG	GND	X7R, ≥1μF, 10V
C _{BSTx}	BSTx	SHx	X7R, 1μF, 25V
C _{GCTRL}	GCTRL	GND	X5R or X7R, 2nF, 10V
R _{nFAULT}	1.8 to 5V Supply	nFAULT	5.1kΩ, Pullup resistor
R _{FG}	1.8 to 5V Supply	FG	5.1kΩ, Pullup resistor
R _{SDA}	1.8 to 5V Supply	SDA	5.1kΩ, Pullup resistor
R _{SCL}	1.8 to 5V Supply	SCL	5.1kΩ, Pullup resistor
R _{BRAKE}	BRAKE	GND	Optional ≤ 10kΩ resistor for better noise immunity, if BRAKE pin is used
R _{DIR}	DIR	AGND	Optional ≤ 10kΩ resistor for better noise immunity, if DIR pin is used

Note

1. AVDD and DVDD capacitors must have an effective capacitance between 0.5μF and 2.8μF after operating voltage (AVDD or DVDD) and temperature derating.
2. The internal pull-up resistor (to AVDD) for both FG and nFAULT pins can be enabled by configuring PULLUP_ENABLE to 1b. Any change to this bit needs to be written to EEPROM followed by a power recycle to take effect. When PULLUP_ENABLE is set to 1b, no external pull-up resistor must be provided.
3. DIR pin has an internal pull-down resistor of 100kΩ. When this pin is used, an additional pull-down resistor of 10kΩ can be added externally for additional noise immunity.
4. SPEED/WAKE pin has an internal pull-down resistor of 1MΩ. In analog speed input mode, a designed for R-C filter can be added externally to reduce noise. In PWM speed input mode, SPEED_PIN_GLITCH_FILTER can be appropriately configured for glitch rejection.

7.3.1 Three Phase BLDC Gate Drivers

The MCF8329HS device integrates three half-bridge gate drivers, each capable of driving high-side and low-side N-channel power MOSFETs. A charge pump is used to generate the GVDD to supply the correct gate bias voltage across a wide operating voltage range. The low side gate outputs are driven directly from GVDD, while the high side gate outputs are driven using a bootstrap circuit with an integrated diode, and an internal trickle charge pump provides support for 100% duty cycle operation.

7.3.2 Gate Drive Architecture

The gate driver device use a complimentary, push-pull topology for both the high-side and low-side drivers. This topology allows for both a strong pullup and pulldown of the external MOSFET gates. The low side gate drivers are supplied directly from the GVDD regulator supply. For the high-side gate drivers a bootstrap diode and capacitor are used to generate the floating high-side gate voltage supply. The bootstrap diode is integrated and an external bootstrap capacitor is used on the BSTx pin. To support 100% duty cycle control, a trickle charge

pump is integrated into the device. The trickle charge pump is connected to the BSTx node to prevent voltage drop due to the leakage currents of the driver and external MOSFET.

The high-side gate driver has semi-active pull down and low side gate has passive pull down to help prevent the external MOSFET from turning ON during sleep state or when power supply is disconnected.

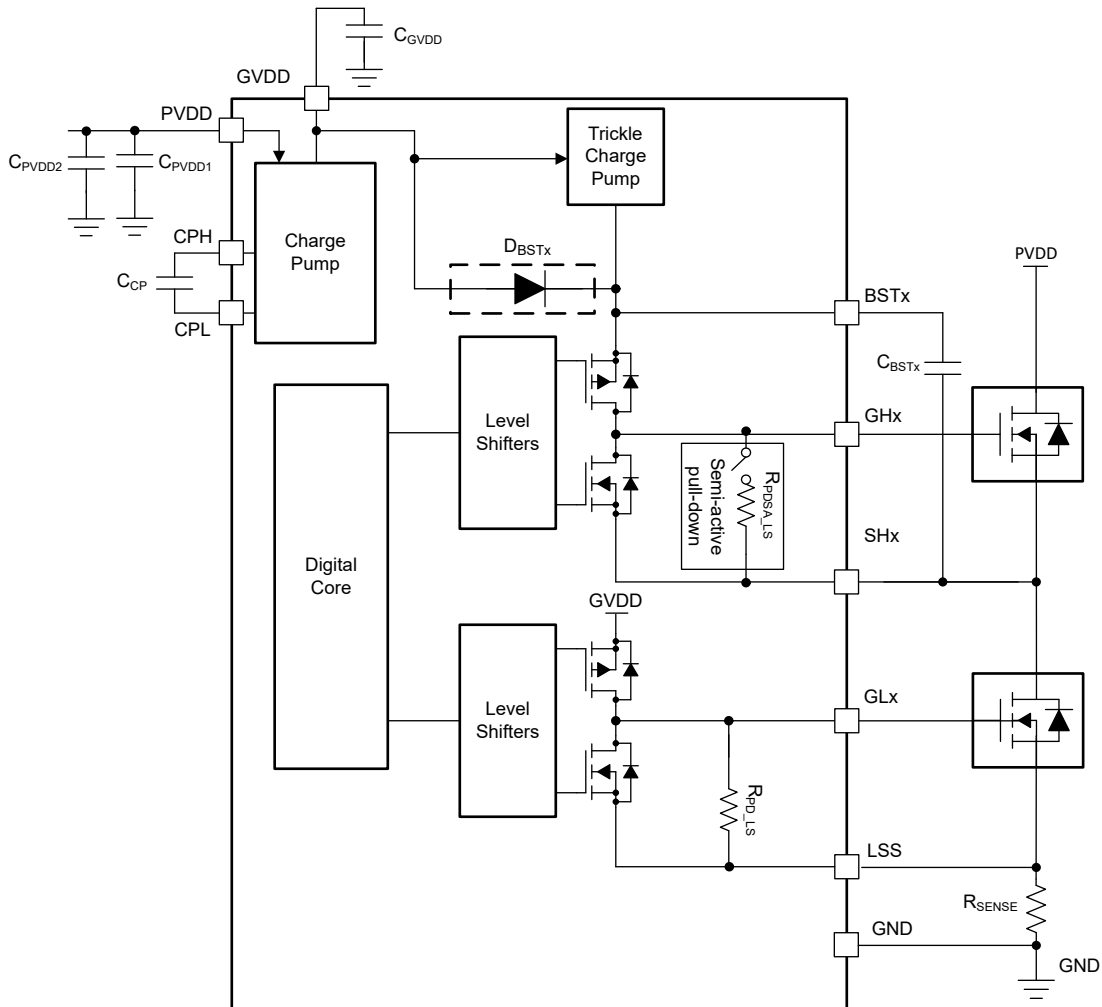

Figure 7-2. Gate Driver Block Diagram

7.3.2.1 Dead time and Cross Conduction Prevention

The MCF8329HS provides digital dead time insertion between the high side and low side PWM signals, to prevent both external MOSFETs of each half-bridge from switching on at the same time. Digital dead time can be adjusted by configuring the EEPROM register DIG_DEAD_TIME.

The applied dead time depends on the internal clock frequency configured by CLOCK_FREQUENCY. Refer to [Table 7-11](#) for more details.

7.3.3 AVDD Linear Voltage Regulator

A 3.3V or 5V (configured by AVDD_VOL_SEL), 80mA linear regulator is integrated into the MCF8329HS and is available for use by external circuitry. If VREG is connected to AVDD, then only 50mA is available for use by external circuitry. The output of the LDO is fixed to 3.3V. This regulator can provide the supply voltage for a low-power MCU or other circuitry with low supply current needs. The output of the AVDD regulator is bypassed near the AVDD pin with a X7R, 1µF or 2.2µF, 10V ceramic capacitor routed back to the AGND pin.

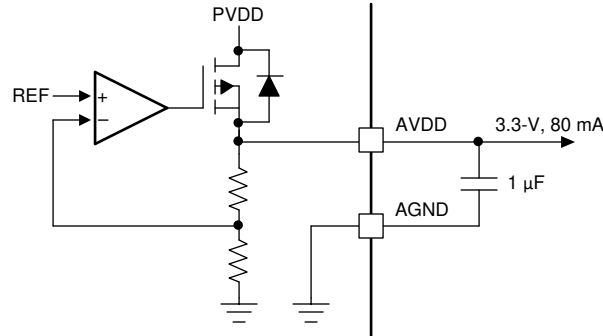

Figure 7-3. AVDD Linear Regulator Block Diagram

The power dissipated in the device by the AVDD linear regulator can be calculated as shown in [Equation 1](#),

$$P = (V_{PVDD} - V_{AVDD}) \times I_{AVDD} \quad (1)$$

For example, at a V_{PVDD} of 24V, drawing 20mA out of AVDD (output at 3.3V) results in power dissipation as shown in [Equation 2](#),

$$P = (24 \text{ V} - 3.3 \text{ V}) \times 20 \text{ mA} = 414 \text{ mW} \quad (2)$$

7.3.4 DVDD Voltage Regulator

VREG pin is used as the supply input for the integrated DVDD voltage regulator. There are several options available for providing supply voltage to VREG pin, either an external 3V to 5.5V supply (30mA source) can be used or AVDD can be connected to VREG or an external MOSFET controlled by GCTRL pin can be used.

7.3.4.1 AVDD Powered VREG

When neither external MOSFET regulator nor external supply is used, connect AVDD to VREG pin (see [Figure 7-4](#)). In this mode digital circuitry which are connected to DVDD is powered using AVDD. In this mode capability AVDD of supporting external load is reduced to 50mA.

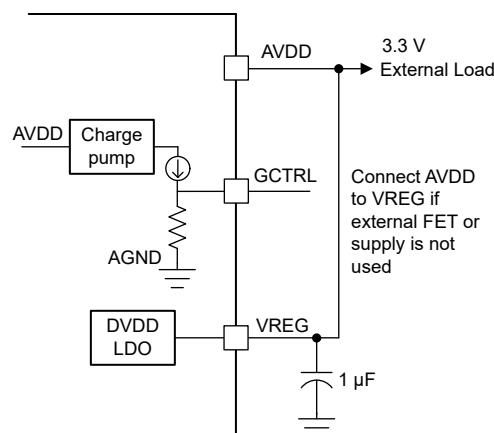

Figure 7-4. AVDD Powering VREG

7.3.4.2 External Supply for VREG

MCF8329HS provides provision to connect the external supply voltage to VREG pin (see [Figure 7-5](#)). In this mode GCTRL pin must be left floating and external regulator is connected to VREG pin. When external MOSFET or external supply is used to power DVDD then maximum external load supported by AVDD is 80mA

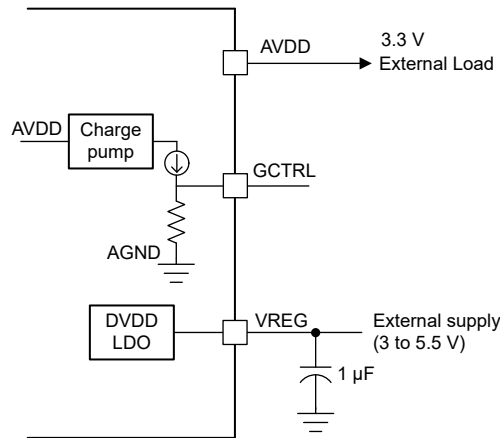

Figure 7-5. External Supply for VREG

7.3.4.3 External MOSFET for VREG Supply

MCF8329HS provides option to drive external MOSFET which can act as regulator and can be used to power internal digital circuitry through VREG pin. In this case VREG must not be connected to AVDD or external 3.3V/5V power supply. This option of connecting external MOSFET can be used to reduce power dissipation in MCF8329HS and transfer the power loss to the external MOSFET, for use cases that have thermal challenges.

The $V_{GS(th)}$ of external MOSFET has to be selected to maintain that the VREG voltage is between 2.2V to 5.5V across operating conditions. Refer [Section 10.2.1](#) for application example design calculations. The input capacitance of external MOSFET need to be less than 2nF to meet startup time $t_{EX_SL_DR_ANA}$ (Analog input) or $t_{EX_SL_DR_PWM}$ (PWM input).

Note

The GCTRL pin is a high impedance node ($> 1M\Omega$) and this pin must not be loaded externally other than the external MOSFET gate and C_{GCTRL} . External loading on GCTRL pin (to GND) reduces the voltage at GCTRL pin and VREG pin.

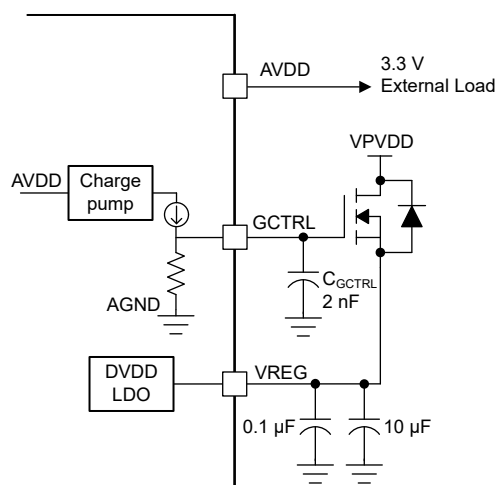

Figure 7-6. External MOSFET Voltage Regulator for VREG

7.3.5 Low-Side Current Sense Amplifier

MCF8329HS integrates a high-performance low-side current sense amplifier for current measurements using a low-side shunt resistor. Low-side current measurements are used for multiple control features and protections in MCF8329HS. The current sense amplifiers feature configurable gain (5V/V, 10V/V, 20V/V, and 40V/V) through

EEPROM setting. The current sense amplifier can support sensing bidirectional current through the low-side shunt resistor.

MCF8329HS internally generates common mode voltage of $V_{REF}/2$ to obtain maximum resolution for current measurement for both the direction of current. V_{REF} is an internally generated reference voltage having a typical value of 3V.

Use [Equation 3](#) to design the value of the shunt resistor (R_{SENSE}) connected between SP and SN, for the range of current (I) through the low side single shunt and the selected current sense amplifier gain configured by EEPROM bits `CSA_GAIN`.

$$R_{SENSE} = \frac{V_{SO} - \frac{V_{REF}}{2}}{CSA_GAIN \times I} \quad (3)$$

Note

1. TI recommends designing the shunt resistor R_{SENSE} value to limit the current sense amplifier output voltage (V_{SO}) between 0.25V and 3V across the operating range of low-side single shunt resistor current (I) at the selected gain of `CSA_GAIN`. Appropriately size the shunt resistor power rating based on the I^2R_{SENSE} losses with sufficient margin.
2. `SINGLE_SHUNT_BLANKING_TIME` can be used to set the blanking window for current sampling (after a PWM edge) till the sensed current settles to a noise-free, steady value. A higher `SINGLE_SHUNT_BLANKING_TIME` reduces noise in sensed current but is also reduce the maximum modulation index that can be applied - `SINGLE_SHUNT_BLANKING_TIME` must be suitably set to optimize between maximum modulation index (motor speed) and minimal noise in sensed current.
3. `DYNAMIC_SAMPLING_EN` can be set to 1b to enable dynamic current sampling to reduce the current harmonics caused by blanking time; when dynamic current sampling is enabled there can be a DC offset in motor phase currents.

7.3.6 Device Interface Modes

MCF8329HS supports the I²C interface to provide end application designs focused on either flexibility or simplicity. Along with the I²C interface, the device supports I/O pins like FG, nFAULT, DIR, EXT_CLK, SPEED/WAKE, DRVOFF.

7.3.6.1 Interface - Control and Monitoring

- **BRAKE:** When BRAKE pin is driven 'High', MCF8329HS enters brake state. Brake state is low side braking (see [Section 7.3.22.2](#)). MCF8329HS decreases output speed to a value defined by `BRAKE_SPEED_THRESHOLD` before entering brake state. As long as BRAKE is driven 'High', MCF8329HS stays in brake state. Brake pin input can be overwritten by configuring `BRAKE_INPUT` over the I²C interface.
- **DIR:** The DIR pin decides the direction of motor spin; when driven 'High', the sequence is OUTA → OUTB → OUTC, and when driven 'Low' the sequence is OUTA → OUTC → OUTB. DIR pin input can be overwritten by configuring `DIR_INPUT` over the I²C interface.
- **DRVOFF:** When DRVOFF pin is driven 'High', MCF8329HS turns off all external MOSFETs by putting the gate drivers into the pull-down state. When DRVOFF is driven 'Low', MCF8329HS returns to normal state of operation, as if restarting the motor. DRVOFF does not cause the device to go to sleep or standby mode; the digital core is still active.
- **SPEED/WAKE:** The SPEED/WAKE pin is used to control motor speed (or power or current or modulation index) and wake up MCF8329HS from sleep mode. SPEED/WAKE pin can be configured to accept PWM, frequency or analog control input signals. The pin is used to enter and exit from sleep and standby mode.
- **DACOUT/SOx/SPEED_ANA:** The DACOUT/SOx/SPEED_ANA pin provides a multiplexed functionality and the pin can be configured as a DACOUT output pin or current sense amplifier output pin or as speed (or power or current or open loop voltage) control analog input pin. With the pin DACOUT/SOx/SPEED_ANA configured as DACOUT, the device allows monitoring of algorithm variables, speed etc (see [Section](#)

7.5.2) . With the pin DACOUT/SOx/SPEED_ANA configured as SOx, the device allows monitoring of integrated current sense amplifier output (V_{SOx}). With the pin DACOUT/SOx/SPEED_ANA configured as SPEED_ANA enable the user to give analog control input for speed or power or voltage through the DACOUT/SOx/SPEED_ANA pin and in that case the SPEED/WAKE pin can be used as an independent speed or standby control input pin. The pin functionality can be configured through EEPROM register bit DAC_SOX_ANA_CONFIG.

- **EXT_CLK**: The EXT_CLK pin can be used to provide an external clock reference and in that case the internal clock gets calibrated using the external clock.
- **HALL_IN**: The HALL_IN pin (mux'ed with EXT_CLK) can be used to provide a digital Hall input signal for redundancy in motor lock detection.
- **FG**: The FG pin provides pulses which are proportional to motor speed (see [Section 7.3.23](#)).
- **nFAULT**: The nFAULT pin provides fault status in device or motor operation.

7.3.6.2 I²C Interface

The MCF8329HS supports an I²C serial communication interface that allows an external controller to send and receive data. This I²C interface lets the external controller configure the EEPROM and read detailed fault and motor state information. The I²C bus is a two-wire interface using the SCL and SDA pins which are described as follows:

- The SCL pin is the clock signal input.
- The SDA pin is the data input and output.

7.3.7 Motor Control Input Options

The MCF8329HS offers four ways of controlling the motor:

1. **SPEED Control:** In speed control mode, the speed of the motor is controlled using a closed loop PI control according to the input reference.
2. **POWER Control:** In power control mode, the DC input power of the inverter power stage is controlled using a closed loop PI control according to the input reference.
3. **CURRENT Control:** In current control mode, the torque controlling current (i_q) is controlled using a closed loop PI control according to the input reference. In this mode the speed/power control loop is disabled.
4. **MODULATION INDEX Control (VOLTAGE Control):** In voltage control mode, the voltage applied to the motor is controlled according to the input reference.

The device can accept four types of input reference signal as configured by SPEED_MODE.

- PWM input on SPEED/WAKE pin by varying duty cycle of input signal
- Frequency input on SPEED/WAKE pin by varying frequency of input signal
- Analog input on SPEED/WAKE pin or DACOUT/SOx/SPEED_ANA pin by varying amplitude of input signal
- Over I²C by configuring DIGITAL_SPEED_CTRL

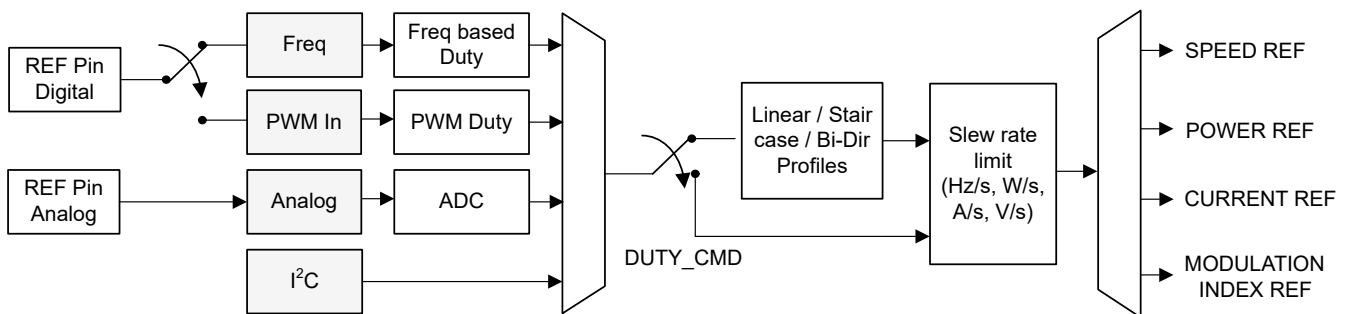

Figure 7-7. Multiplexing the Reference Input Command

The signal path from REF (SPEED/WAKE) pin input (or I²C based speed input) to output reference (SPEED REF or POWER REF or CURRENT REF or MODULATION INDEX REF) shown in [Figure 7-7](#).

7.3.7.1 Analog-Mode Motor Control

Analog input based motor control can be configured by setting SPEED_MODE to 00b. In this mode, the duty command (DUTY CMD) varies with the analog voltage input (V_{SPEED}) on the SPEED/WAKE pin. When $0 < V_{SPEED} < V_{EN_SB}$, DUTY CMD is set to zero and the motor is stopped. When $V_{EN_SB} < V_{SPEED} < V_{ANA_FS}$, DUTY CMD varies linearly with V_{SPEED} as shown in [Figure 7-8](#). When $V_{SPEED} > V_{ANA_FS}$, DUTY CMD is clamped to 100%.

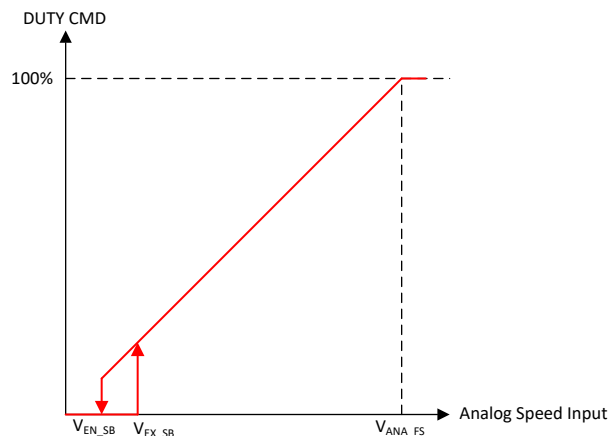

Figure 7-8. Analog-Mode Speed Control

7.3.7.2 PWM-Mode Motor Control

PWM-based motor control can be configured by setting SPEED_MODE to 01b. In this mode, the PWM duty cycle applied to the SPEED/WAKE pin can be varied from 0 to 100%, and duty command (DUTY_CMD) varies linearly with the applied PWM duty cycle. When $0 \leq \text{Duty}_{\text{SPEED}} \leq \text{Duty}_{\text{EN_SB}}$, DUTY_CMD is set to zero. When $\text{Duty}_{\text{EX_SB}} \leq \text{Duty}_{\text{SPEED}} \leq 100\%$, DUTY_CMD varies linearly with $\text{Duty}_{\text{SPEED}}$ as shown in Figure 7-9. $\text{Duty}_{\text{EX_SB}}$ and $\text{Duty}_{\text{EN_SB}}$ are the standby entry and exit thresholds - refer Section 7.4.1.2 for more information on $\text{Duty}_{\text{EX_SB}}$ and $\text{Duty}_{\text{EN_SB}}$. The frequency of the PWM input signal applied to the SPEED/WAKE pin is defined as f_{PWM} and the range for this frequency can be configured through SPEED_RANGE_SEL.

Note

1. f_{PWM} is the frequency of the PWM signal the device can accept at the SPEED/WAKE pin to control motor speed. It does not correspond to the PWM output frequency that is applied to the motor phases. The PWM output frequency can be configured through PWM_FREQ_OUT (see Section 7.3.19).
2. SLEEP_ENTRY_TIME should be set longer than the off time in the PWM signal ($V_{\text{SPEED}} < V_{\text{IL}}$) at the lowest duty input. For example, if f_{PWM} is 10kHz and the lowest duty input is 2%, SLEEP_ENTRY_TIME should be more than 98 μs to ensure there is no unintended sleep/standby entry.

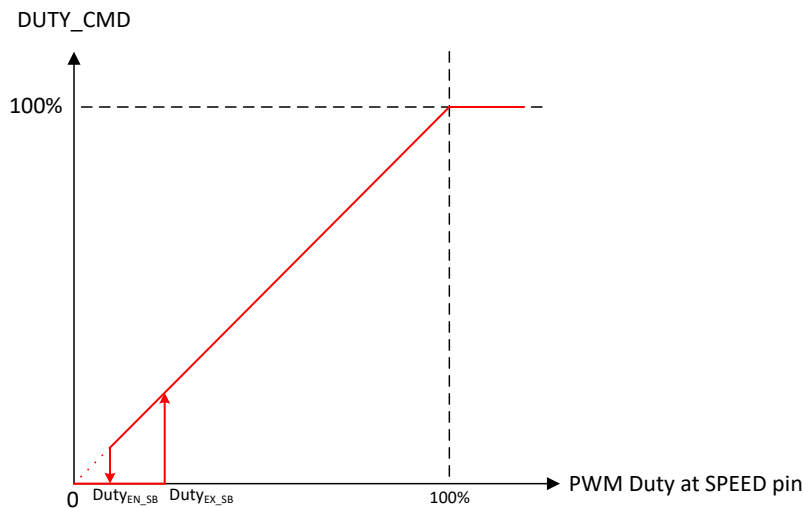

Figure 7-9. PWM-Mode Motor Control

7.3.7.3 Frequency-Mode Motor Control

Frequency-based motor control is configured by setting SPEED_MODE to 11b. In this mode, duty command varies linearly as a function of the frequency of the square wave input at the SPEED (SPEED/WAKE) pin. When $0 \leq \text{Freq}_{\text{SPEED}} \leq \text{Freq}_{\text{EN_SB}}$, DUTY_CMD is set to zero. When $\text{Freq}_{\text{EX_SB}} \leq \text{Freq}_{\text{SPEED}} \leq \text{INPUT_MAXIMUM_FREQ}$, DUTY_CMD varies linearly with $\text{Freq}_{\text{SPEED}}$ as shown in Figure 7-10. $\text{Freq}_{\text{EX_SB}}$ and $\text{Freq}_{\text{EN_SB}}$ are the standby entry and exit thresholds - refer Section 7.4.1.2 for more information on $\text{Freq}_{\text{EX_SB}}$ and $\text{Freq}_{\text{EN_SB}}$. Input frequency greater than INPUT_MAXIMUM_FREQ clamps the DUTY_CMD to 100%.

Note

TI recommends a logic low signal on the SPEED/WAKE pin to provide a zero reference in frequency mode control.

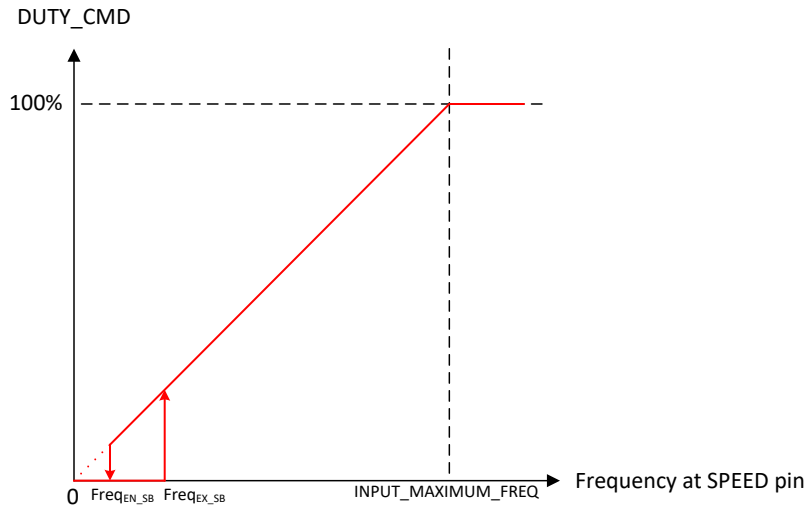

Figure 7-10. Frequency-Mode Motor Control

7.3.7.4 I²C based Motor Control

I²C based serial interface can be used for motor control by setting SPEED_MODE to 10b. In this mode, the duty command can be written directly into DIGITAL_SPEED_CTRL register. The sleep entry and exit are controlled through SLEEP/WAKE as described in [Table 7-8](#).

7.3.7.5 Input Control Signal Profiles

MCF8329HS supports three different kinds of profiles (linear, step, forward-reverse) to convert the DUTY_CMD to the reference control signal. The input control reference signal can be motor speed, DC input power, motor current (i_q), or motor voltage (modulation index control) as configured by CTRL_MODE. The different profiles can be configured through REF_PROFILE_CONFIG. When REF_PROFILE_CONFIG is set to 00b, the profiler is not applied and the input reference is same as the duty command as explained in [Section 7.3.7.5.5](#).

In speed control mode, the profiler output REF_X corresponds to percentage of Maximum Speed (configured by MAX_SPEED) as shown in [Equation 4](#). In power control mode, the profiler output REF_X corresponds to percentage of Maximum Power (configured by MAX_POWER) as shown in [Equation 5](#). In the current control mode (i_q control) the profiler output REF_X corresponds to the percentage of ILIMIT as shown in [Equation 6](#). In voltage control mode (Modulation index control mode) REF_X corresponds to the percentage of V_d and V_q modulation index applied voltage to the motor as shown in [Equation 7](#).

$$SPEED\ REF(Hz) = \frac{REF_X}{256} \times Maximum\ Speed\ (Hz) \quad (4)$$

$$POWER\ REF(W) = \frac{REF_X}{256} \times Maximum\ Power\ (W) \quad (5)$$

$$CURRENT\ (i_q)\ REF(A) = \frac{REF_X}{256} \times ILIMIT\ (A) \quad (6)$$

$$MODULATION\ INDEX\ REF(V_s) = \frac{REF_X}{256} \times 100\% \quad (7)$$

7.3.7.5.1 Linear Control Profiles

Note

For all three profiles (linear, step, forward/reverse),

- When MCF8329HS is configured as a sleep device, a zero input reference (0V in analog mode, 0% duty in PWM mode, DIGITAL_SPEED_CTRL = 0b in I²C mode or 0Hz in frequency mode) will stop the motor.
- When MCF8329HS is configured as a standby device, a zero input command will result in motor operating at reference level (speed, power, current or voltage) set by REF_OFF1.

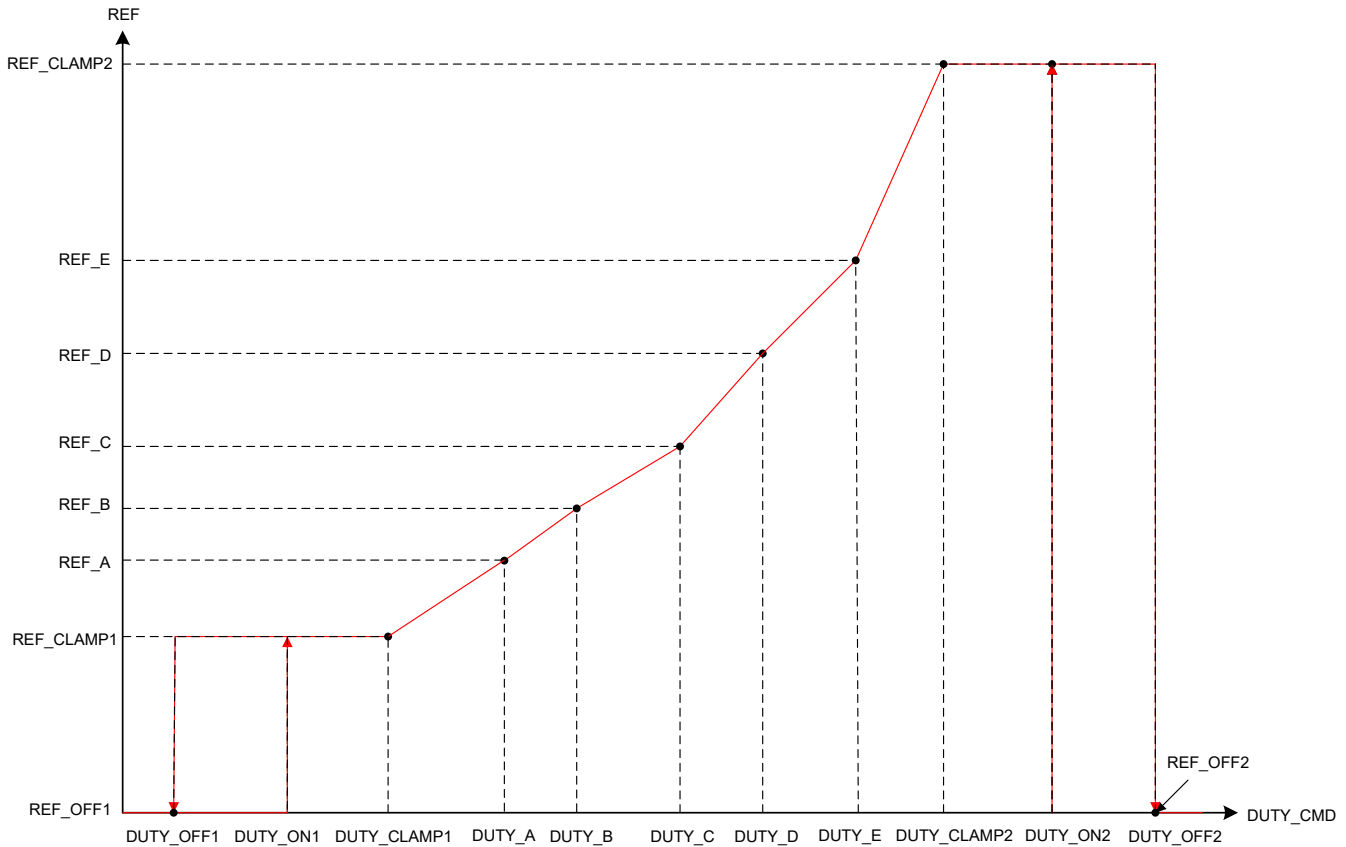

Figure 7-11. Linear Control Profiles

Linear control profiles can be configured by setting REF_PROFILE_CONFIG to 01b. Linear profiles feature input control references which change linearly between REF_CLAMP1 and REF_CLAMP2 with different slopes which can be set by configuring DUTY_x and REF_x combination.

- DUTY_OFF1 configures the duty command below which the reference will be REF_OFF1.
- DUTY_OFF1 and DUTY_ON1 configures a hysteresis around reference control input REF_CLAMP1 and REF_OFF1 as shown in [Figure 7-11](#).
- DUTY_CLAMP1 configures the duty command till which reference will be constant with a value REF_CLAMP1. DUTY_CLAMP1 can be placed anywhere between DUTY_OFF1 and DUTY_A.
- DUTY_A configures the duty command for reference REF_A. The reference changes from REF_CLAMP1 to REF_A linearly between DUTY_CLAMP1 and DUTY_A. DUTY_A to DUTY_E has to be in the same order as shown in [Figure 7-11](#).
- DUTY_B configures the duty command for reference REF_B. The reference changes linearly between DUTY_A and DUTY_B.

- DUTY_C configures the duty command for reference REF_C. The reference changes linearly between DUTY_B and DUTY_C.
- DUTY_D configures the duty command for reference REF_D. The reference changes linearly between DUTY_C and DUTY_D.
- DUTY_E configures the duty command for reference REF_E. The reference changes linearly between DUTY_D and DUTY_E.
- DUTY_CLAMP2 configures the duty command above which the reference will be constant at REF_CLAMP2. REF_CLAMP2 configures this constant reference between DUTY_CLAMP2 and DUTY_OFF2. The reference changes linearly between DUTY_E and DUTY_CLAMP2. DUTY_CLAMP2 can be placed anywhere between DUTY_E and DUTY_OFF2.
- DUTY_OFF2 and DUTY_ON2 configures a hysteresis around reference control input REF_CLAMP2 and REF_OFF2 as shown in [Figure 7-11](#).
- DUTY_OFF2 configures the duty command above which the reference will change from REF_CLAMP2 to REF_OFF2.

7.3.7.5.2 Staircase Control Profiles

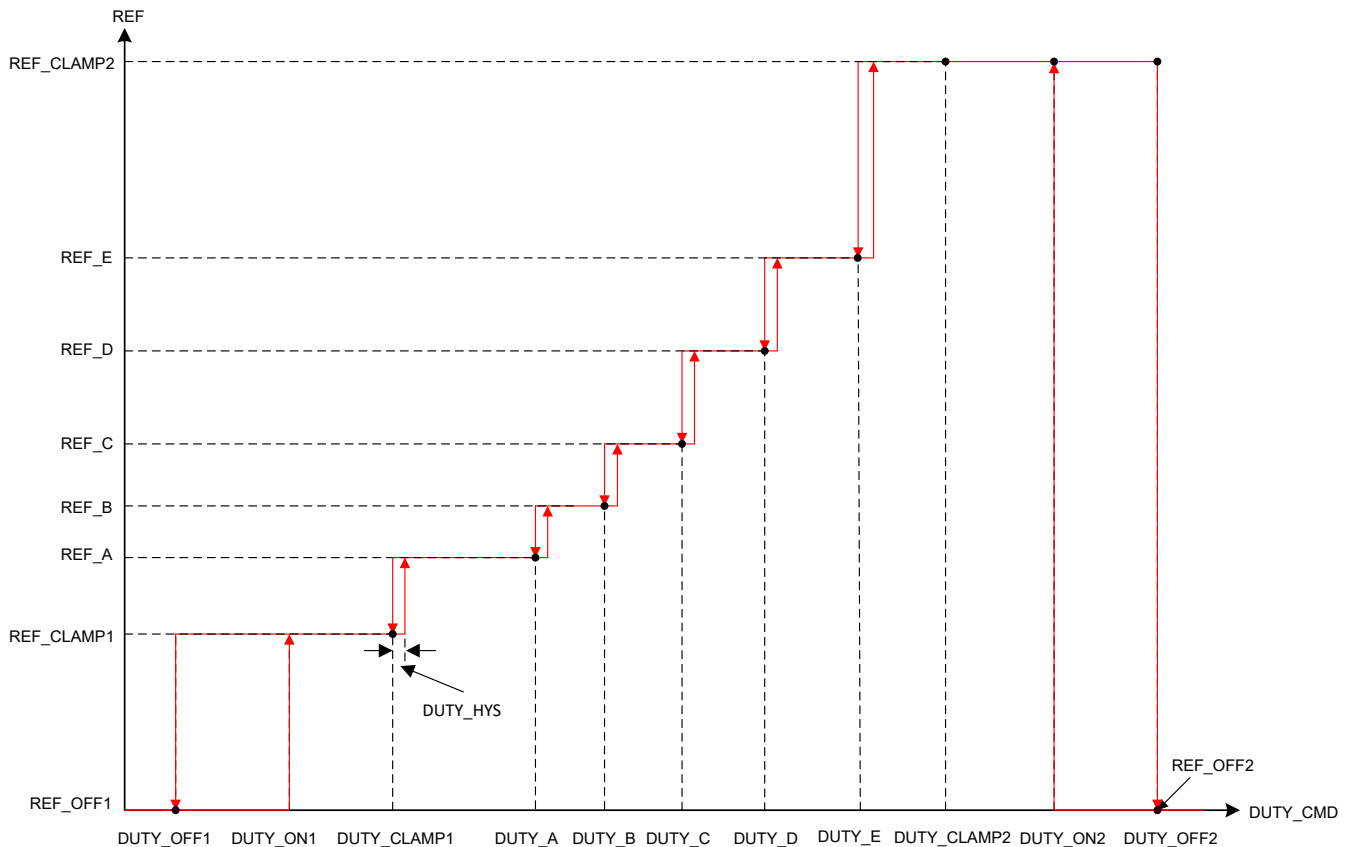

Figure 7-12. Staircase Control Profiles

Staircase control profiles can be configured by setting REF_PROFILE_CONFIG to 10b. Staircase profiles feature input control reference changes in steps between REF_CLAMP1 and REF_CLAMP2, by configuring DUTY_x and REF_x.

- DUTY_OFF1 configures the duty command below which the reference will be REF_OFF1.
- DUTY_OFF1 and DUTY_ON1 configures a hysteresis around reference control input REF_CLAMP1 and REF_OFF1 as shown in [Figure 7-12](#).

- DUTY_CLAMP1 configures the duty command till which reference will be constant. REF_CLAMP1 configures this constant reference between DUTY_OFF1 and DUTY_CLAMP1. DUTY_CLAMP1 can be placed anywhere between DUTY_OFF1 and DUTY_A.
- DUTY_A configures the duty command for reference REF_A. There is a step change in reference from REF_CLAMP1 to REF_A at DUTY_CLAMP1. DUTY_A to DUTY_E has to be in the same order as shown in [Figure 7-12](#).
- DUTY_B configures the duty command for reference REF_B. There is a step change in reference from REF_A to REF_B at DUTY_A.
- DUTY_C configures the duty command for reference REF_C. There is a step change in reference from REF_B to REF_C at DUTY_B.
- DUTY_D configures the duty command for reference REF_D. There is a step change in reference from REF_C to REF_D at DUTY_C.
- DUTY_E configures the duty command for reference REF_E. There is a step change in reference from REF_D to REF_E at DUTY_D.
- DUTY_CLAMP2 configures the duty command above which the reference will be constant at REF_CLAMP2. REF_CLAMP2 configures this constant reference between DUTY_CLAMP2 and DUTY_OFF2. There is a step change in reference from REF_E to REF_CLAMP2 at DUTY_E. DUTY_CLAMP2 can be placed anywhere between DUTY_E and DUTY_OFF2.
- DUTY_OFF2 and DUTY_ON2 configures a hysteresis around reference control input REF_CLAMP2 and REF_OFF2 as shown in [Figure 7-12](#).
- DUTY_OFF2 configures the duty command above which the reference will change from REF_CLAMP2 to REF_OFF2.
- DUTY_HYS configures the hysteresis during every step change at DUTY_CLAMP1, DUTY_A to DUTY_E.

7.3.7.5.3 Forward-Reverse Profiles

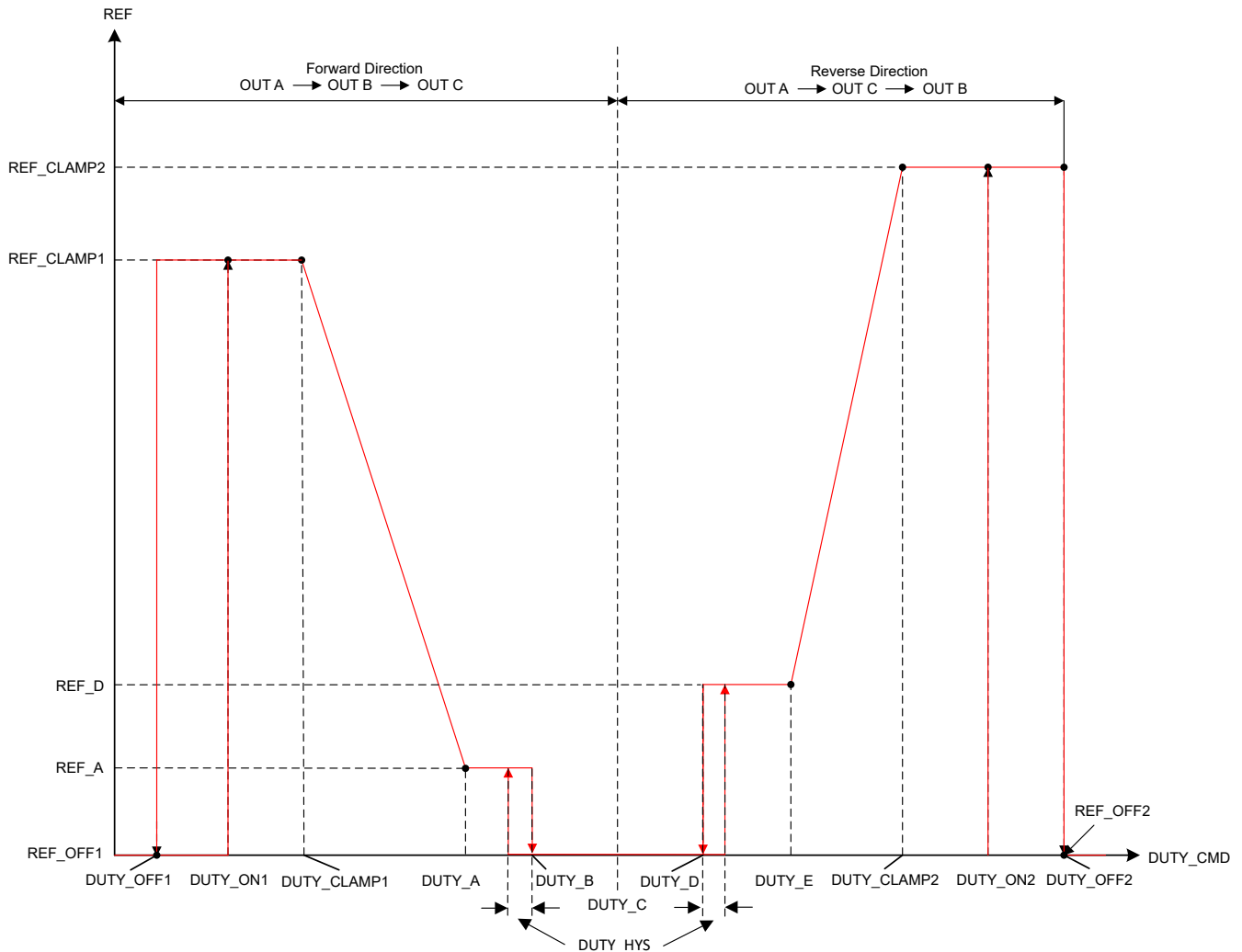

Figure 7-13. Forward Reverse Control Profiles

Forward-Reverse control profiles can be configured by setting REF_PROFILE_CONFIG to 11b. Forward-Reverse profiles feature direction change through adjusting the duty command. DUTY_C configures duty command at which the direction changes. The Forward-Reverse speed profile can be used to eliminate the separate signal used to control the motor direction.

Note

The direction change functionality through DIR pin and DIR_INPUT bits are disabled in forward reverse profile mode.

- DUTY_OFF1 configures the duty command below which the reference is REF_OFF1.
- DUTY_OFF1 and DUTY_ON1 configures a hysteresis around reference control input REF_CLAMP1 and REF_OFF1 as shown in [Figure 7-13](#).
- DUTY_CLAMP1 configures the duty command till which reference is constant. REF_CLAMP1 configures this constant reference between DUTY_OFF1 and DUTY_CLAMP1. DUTY_CLAMP1 can be placed anywhere between DUTY_OFF1 and DUTY_A.
- DUTY_A configures the duty command for reference REF_A. The reference changes linearly between DUTY_CLAMP1 and DUTY_A. DUTY_A to DUTY_E has to be in the same order as shown in [Figure 7-13](#).

- DUTY_B configures the duty command above which MCF8329HS is in off state. The reference remains constant at REF_A between DUTY_A and DUTY_B.
- DUTY_C configures the duty command at which the direction is changed
- DUTY_D configures the duty command above which the MCF8329HS is in running state in the reverse direction. REF_D configures constant reference between DUTY_D and DUTY_E.
- DUTY_E configures the duty command above which reference changes linearly between DUTY_E and DUTY_CLAMP2.
- DUTY_CLAMP2 configures the duty command above which the reference is constant at REF_CLAMP2. REF_CLAMP2 configures this constant reference between DUTY_CLAMP2 and DUTY_OFF2. DUTY_CLAMP2 can be placed anywhere between DUTY_E and DUTY_OFF2.
- DUTY_OFF2 and DUTY_ON2 configures a hysteresis around reference control input REF_CLAMP2 and REF_OFF2 as shown in [Figure 7-13](#).
- DUTY_OFF2 configures the duty command above which the reference changes in the reverse direction from REF_CLAMP2 to REF_OFF2.
- DUTY_HYS configures the hysteresis during step change at DUTY_B and DUTY_D.

7.3.7.5.4 Multi-Reference Mode Operation

Note

The multi-reference (mixed) mode operation is available only when REF_PROFILE_CONFIG is set 01b (linear profile) or 10b (staircase profile).

MCF8329HS provides the option of multi-reference mode operation when MIXED_MODE_CONFIG is set to 01b or 10b. When MIXED_MODE_CONFIG is set to 01b, MCF8329HS operates in speed, current or power reference mode till DUTY_CMD reaches DUTY_C and then switches to voltage reference mode from DUTY_C till 100% duty command as shown in [Figure 7-14](#).

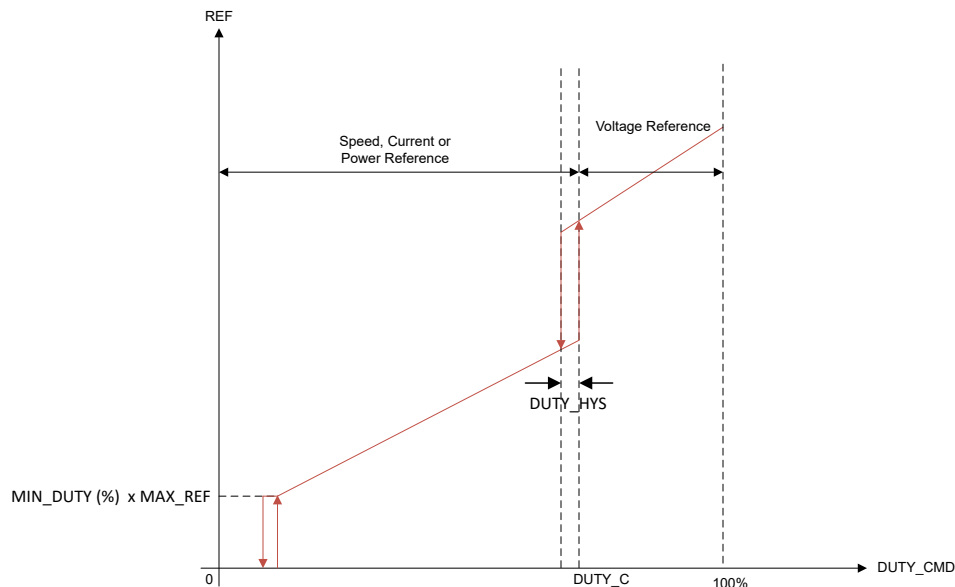

Figure 7-14. Multi-Reference Mode Operation (when MIXED_MODE_CONFIG = 01b)

Conversely, MCF8329HS operates in voltage reference mode till DUTY_C and then switches to speed, current or power reference from DUTY_C till 100% duty command when MIXED_MODE_CONFIG is set to 10b as shown in [Figure 7-15](#).

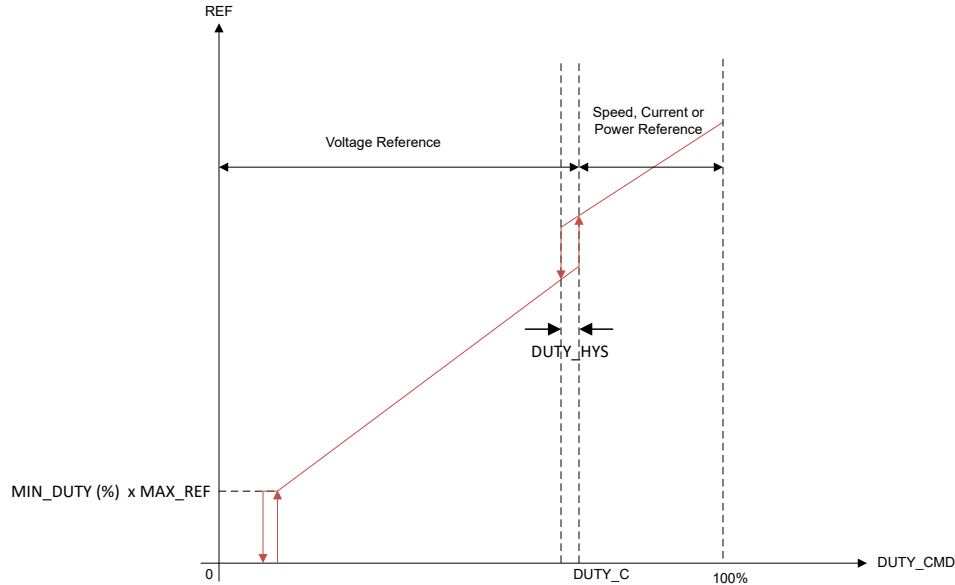

Figure 7-15. Multi-Reference Mode Operation (when MIXED_MODE_CONFIG = 10b)

7.3.7.5.5 Input Reference Transfer Function without Profiler

The input reference can be a speed, power, current or voltage command as configured by CTRL_MODE.

Note

- In this mode, if MIN_DUTY < REF_CLAMP1, the minimum reference is set by REF_CLAMP1 and not MIN_DUTY. For example, if MIN_DUTY is set to 1% and REF_CLAMP1 set to 5%, the minimum reference is REF_CLAMP1 x MAX_REFERENCE. MAX_REFERENCE can be MAX_SPEED, MAX_POWER, ILIMIT or 100% depending on input reference mode.
- Set MIN_DUTY > REF_CLAMP1 for using MIN_DUTY to set the minimum reference.

Speed Reference Transfer Function

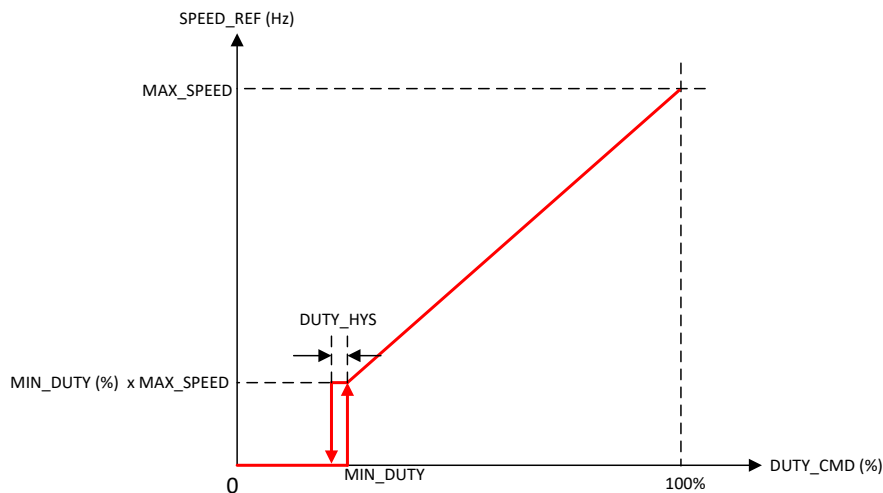

Figure 7-16. Speed Reference Transfer Function

Figure 7-16 shows the relationship between DUTY_CMD and SPEED_REF. MAX_SPEED sets the SPEED_REF at DUTY_CMD of 100%. MIN_DUTY sets the minimum SPEED_REF (MIN_DUTY x

MAX_SPEED). If MAX_SPEED is set to 0Hz, SPEED_REF is clamped to zero (irrespective of DUTY_CMD) and motor is in stopped state.

Power Reference Transfer Function

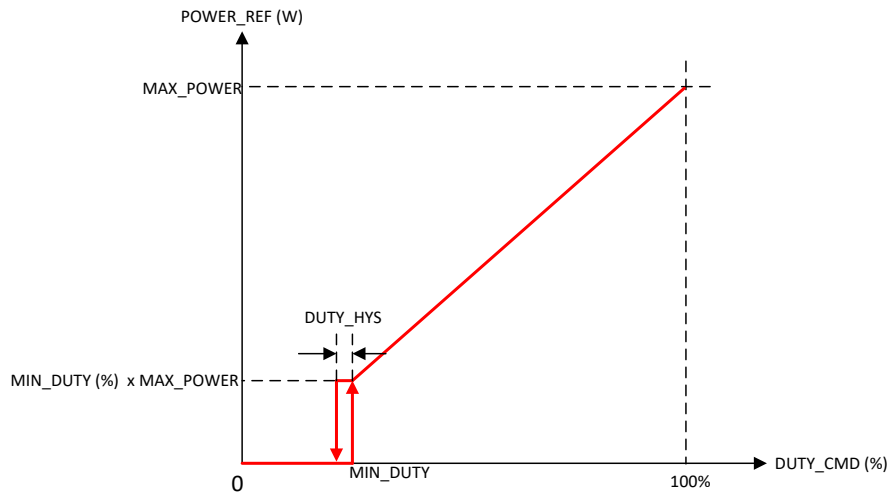

Figure 7-17. Power Reference Transfer Function

Figure 7-17 shows the relationship between DUTY_CMD and POWER_REF. MAX_POWER sets the POWER_REF at DUTY_CMD of 100%. MIN_DUTY sets the minimum POWER_REF (MIN_DUTY x MAX_POWER). If MAX_POWER is set to 0W, POWER_REF is clamped to zero (irrespective of DUTY_CMD) and motor is in stopped state.

Voltage Reference Transfer Function

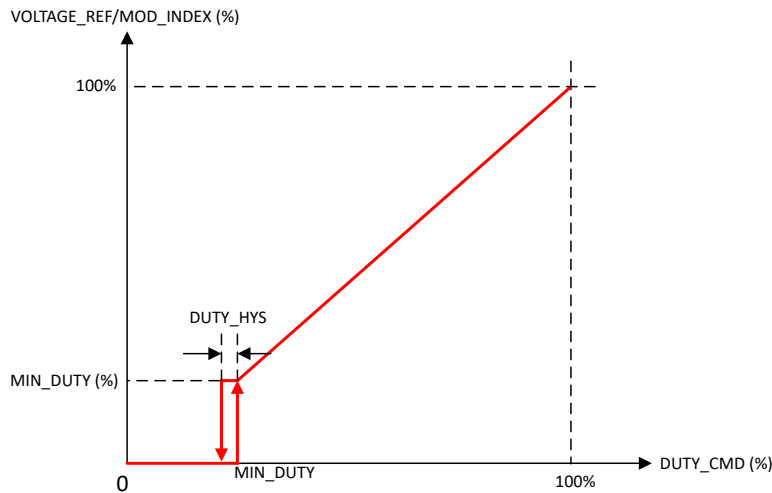

Figure 7-18. Voltage Reference Transfer Function

In voltage reference mode, the phase voltage applied to motor is proportional to the DUTY_CMD (from MIN_DUTY to 100%) as shown in Figure 7-18. For DUTY_CMD less than MIN_DUTY, the applied voltage to motor is clamped to zero.

Current Input Transfer Function

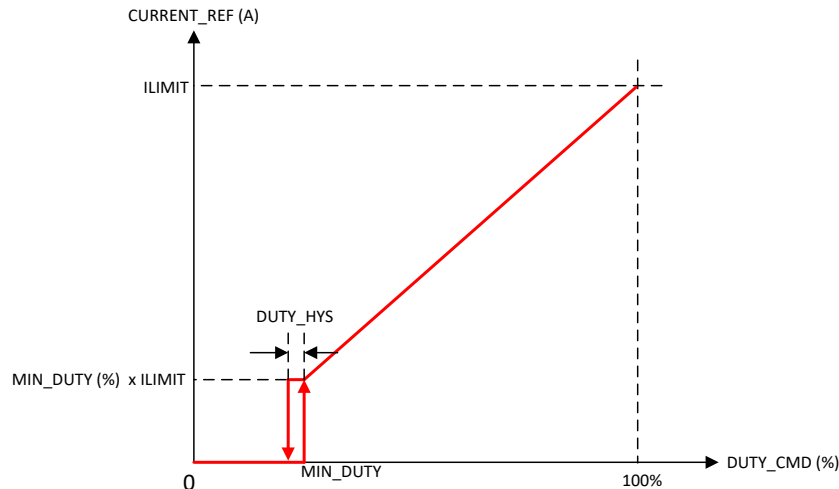

Figure 7-19. Current Reference Transfer Function

Figure 7-19 shows the relationship between DUTY_CMD and CURRENT_REF. ILIMIT sets the CURRENT_REF at DUTY_CMD of 100%. MIN_DUTY sets the minimum CURRENT_REF (MIN_DUTY x ILIMIT).

7.3.8 Bootstrap Capacitor Initial Charging

MCF8329HS provides a way to precharge the bootstrap capacitor during start-up. The algorithm uses a sequence to charge each phase bootstrap capacitor by turning on the external low side MOSFETs using PWM turn on pulses on GLx pins as shown in Figure 7-20. In the charging sequence, the low side MOSFET is switched at a frequency set by PWM FREQUENCY with an on time of $t_{LS_ON_BC}$ (5% on time duty cycle). Each phase is charged for a period equal to one third of BST_CHRG_TIME.

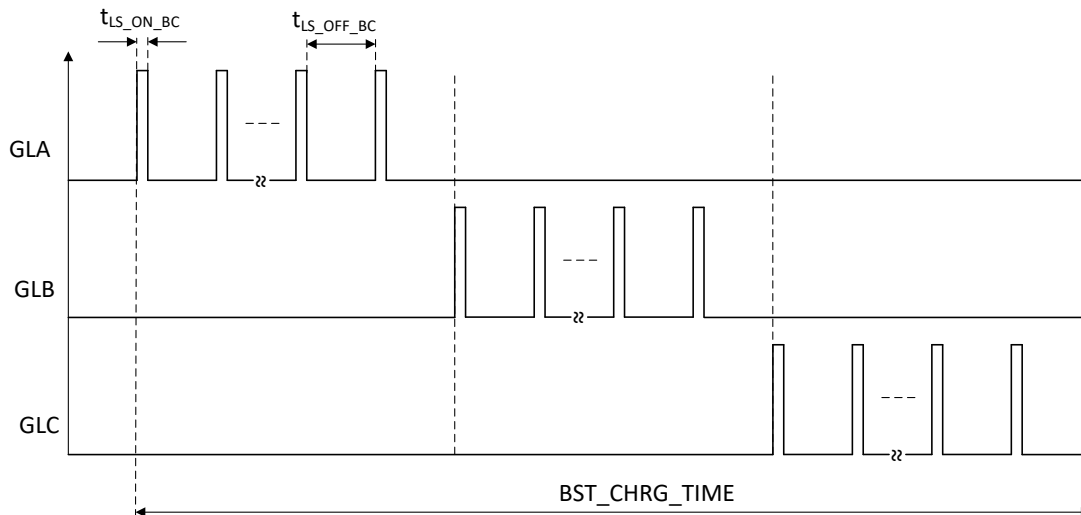

Figure 7-20. Bootstrap Capacitor Precharging at Start-up

7.3.9 Starting the Motor Under Different Initial Conditions

The motor can be in one of three states when MCF8329HS begins the start-up process. The motor may be stationary, spinning in the forward direction, or spinning in the reverse direction. The MCF8329HS includes a number of features to allow for reliable motor start-up under all of these conditions. Figure 7-21 shows the motor start-up flow for each of the three initial motor states.

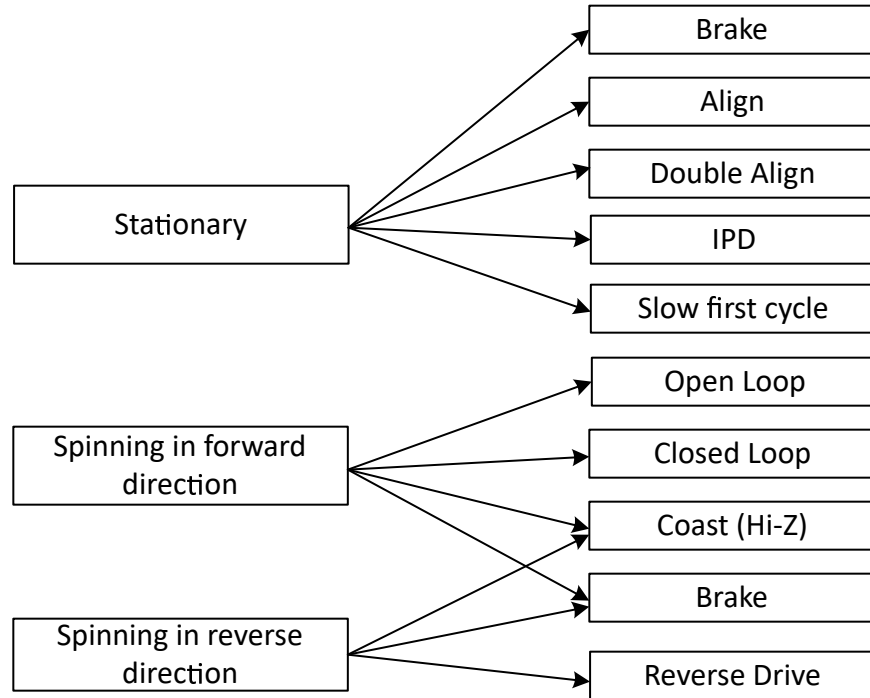

Figure 7-21. Starting the motor under different initial conditions

Note

"Forward" means "spinning in the same direction as the commanded direction", and "Reverse" means "spinning in the opposite direction as the commanded direction".

7.3.9.1 Case 1 – Motor is Stationary

If the motor is stationary, the commutation must be initialized to be in phase with the position of the motor. The MCF8329HS provides various options to initialize the commutation logic to the motor position and reliably start the motor.

- The align and double align techniques force the motor into alignment by applying a voltage across a particular motor phase to force the motor to rotate in alignment with this phase.
- Initial position detect (IPD) determines the position of the motor based on the deterministic inductance variation, which is often present in BLDC motors.
- The slow first cycle method starts the motor by applying a low frequency cycle to align the rotor position to the applied commutation by the end of one electrical rotation.

MCF8329HS also provides a configurable brake option to maintain the motor is stationary before initiating one of the above start-up methods. Device enters open loop acceleration after going through the configured start-up method.

7.3.9.2 Case 2 – Motor is Spinning in the Forward Direction

If the motor is spinning forward (same direction as the commanded direction) with sufficient speed (BEMF), the MCF8329HS resynchronizes with the spinning motor and continues commutation by going directly to closed loop operation. If the motor speed is too low for closed loop operation, MCF8329HS enters open loop operation to accelerate the motor till the motor reaches sufficient speed to enter closed loop operation. By resynchronizing to the spinning motor, the user achieves the fastest possible start-up time for this initial condition. This resynchronization feature can be enabled or disabled through RESYNC_EN. If resynchronization is disabled, the MCF8329HS can be configured to wait for the motor to coast to a stop and/or apply a brake. After the motor has stopped spinning, the motor start-up sequence proceeds as in Case 1, considering the motor is stationary.

7.3.9.3 Case 3 – Motor is Spinning in the Reverse Direction

If the motor is spinning in the reverse direction (the opposite direction as the commanded direction), the MCF8329HS provides several methods to change the direction and drive the motor to the target reference in the commanded direction.

The reverse drive method allows the motor to be driven so that the motor decelerates through zero speed. The motor achieves the shortest possible spin-up time when spinning in the reverse direction.

If reverse drive is not enabled, then the MCF8329HS can be configured to wait for the motor to coast to a stop and/or apply a brake. After the motor has stopped spinning, the motor start-up sequence proceeds as in Case 1, considering the motor is stationary.

Note

Take care when using the reverse drive or brake feature to maintain that the current is limited to an acceptable level and that the supply voltage does not surge as a result of energy being returned to the power supply.

7.3.10 Motor Start Sequence (MSS)

Figure 7-22 shows the motor-start sequence implemented in the MCF8329HS device.

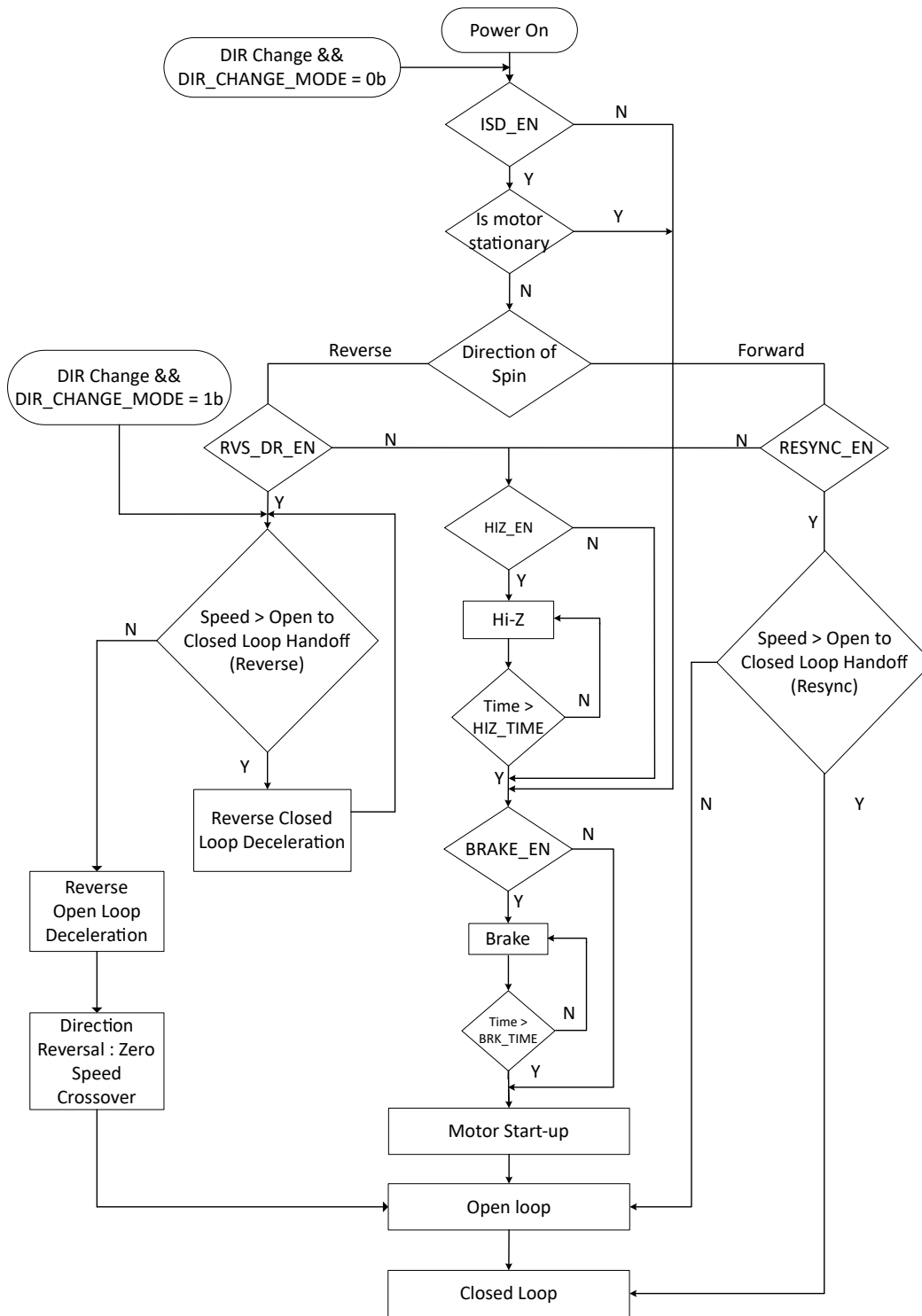

Figure 7-22. Motor Starting-up Flow

Power-On State	This is the initial state of the Motor Start Sequence (MSS). The MSS starts in this state on initial power-up or whenever the MCF8329HS comes out of standby or sleep mode.
DIR Change && DIR_CHANGE_MODE = 0b Judgement	In MCF8329HS, if direction change command is detected and DIR_CHANGE_MODE is set to 0b during any state (including closed loop), the device re-starts the MSS.
ISD_EN Judgement	After power-on, the MCF8329HS MSS enters the ISD_EN judgement where it checks to see if the initial speed detect (ISD) function is enabled (ISD_EN = 1b). If ISD is disabled, the MSS proceeds directly to the BRAKE_EN judgement. If ISD is enabled, MSS advances to the ISD (Is Motor Stationary) state.
ISD State	The MSS determines the initial condition (speed, direction of spin) of the motor (see Initial Speed Detect (ISD)). If motor is deemed to be stationary (motor BEMF < STAT_DETECT_THR), the MSS proceeds to BRAKE_EN judgement. If the motor is not stationary, MSS proceeds to verify the direction of spin.
Direction of Spin Judgement	The MSS determines whether the motor is spinning in the forward or the reverse direction. If the motor is spinning in the forward direction, the MCF8329HS proceeds to the RESYNC_EN judgement. If the motor is spinning in the reverse direction, the MSS proceeds to the RVS_DR_EN judgement.
RESYNC_EN Judgement	If RESYNC_EN is set to 1b, MCF8329HS proceeds to Speed > Open to Closed Loop Handoff (Re-sync) judgement. If RESYNC_EN is set to 0b, MSS proceeds to HIZ_EN judgement.
Speed > Open to Closed Loop Handoff (Re-sync) Judgement	If motor speed > FW_DRV_RESYN_THR, MCF8329HS uses the speed and position information from the ISD state to transition to the closed loop state (see Motor Resynchronization) directly. If motor speed < FW_DRV_RESYN_THR, MCF8329HS transitions to open loop state.
RVS_DR_EN Judgement	The MSS checks to see if the reverse drive function is enabled (RVS_DR_EN = 1). If it is enabled, the MSS transitions to check speed of the motor in reverse direction. If the reverse drive function is not enabled, the MSS advances to the HIZ_EN judgement.
Speed > Open to Closed Loop Handoff (Reverse) Judgement	The MSS checks to see if the reverse speed is high enough for MCF8329HS to decelerate in closed loop. Till the speed (in reverse direction) is high enough, MSS stays in reverse closed loop deceleration. If speed is too low, then the MSS transitions to reverse open loop deceleration.
Reverse Closed Loop, Open Loop Deceleration and Zero Speed Crossover	The MCF8329HS resynchronizes in the reverse direction, decelerates the motor in closed loop till motor speed falls below the handoff threshold. (see Reverse Drive). When motor speed in reverse direction is too low, the MCF8329HS switches to open-loop, decelerates the motor in open-loop, crosses zero speed, and accelerates in the forward direction in open-loop before entering closed loop operation after motor speed is sufficiently high.
HIZ_EN Judgement	The MSS checks to determine whether the coast (Hi-Z) function is enabled (HIZ_EN =1). If the coast function is enabled, the MSS advances to the coast routine. If the coast function is disabled, the MSS advances to the BRAKE_EN judgement.
Coast (Hi-Z) Routine	The device coasts the motor by turning OFF all six MOSFETs for a certain time configured by HIZ_TIME.
BRAKE_EN Judgement	The MSS checks to determine whether the brake function is enabled (BRAKE_EN =1). If the brake function is enabled, the MSS advances to the brake routine. If the brake function is disabled, the MSS advances to the motor start-up state (see Section 7.3.10.4).

Brake Routine	MCF8329HS implements a brake by turning on all three low-side MOSFETS for BRK_TIME.
Closed Loop State	In this state, the MCF8329HS drives the motor with FOC.

Note

User should ensure adequate start up time to fully charge the bootstrap capacitors. One option to charge the boot capacitor is by providing enough time with low side brake at start up. Another option is to use the bootstrap precharging routine. The device will initiate ISD only after bootstrap voltage crosses the UVLO threshold.

7.3.10.1 Initial Speed Detect (ISD)

The ISD function is used to identify the initial condition of the motor and is enabled by setting ISD_EN to 1b. The initial speed, position and direction is determined by sampling the phase voltage through the internal ADC. ISD can be disabled by setting ISD_EN to 0b. If the function is disabled (ISD_EN set to 0b), the MCF8329HS does not perform the initial speed detect function and proceeds to check if the brake routine (BRAKE_EN) is enabled.

7.3.10.2 Motor Resynchronization

The motor resynchronization function works when the ISD and resynchronization functions are both enabled and the device determines that the initial state of the motor is spinning in the forward direction (same direction as the commanded direction). The speed and position information measured during ISD are used to initialize the drive state of the MCF8329HS, which can transition directly into closed loop (or open loop if motor speed is not sufficient for closed loop operation) state without needing to stop the motor. In the MCF8329HS, motor resynchronization can be enabled/disabled through RESYNC_EN bit. If motor resynchronization is disabled, the device proceeds to check if the motor coast (Hi-Z) routine is enabled.

7.3.10.3 Reverse Drive

The MCF8329HS uses the reverse drive function to change the direction of the motor rotation when ISD_EN and RVS_DR_EN are both set to 1b and the ISD determines the motor spin direction to be opposite to that of the commanded direction. Reverse drive includes synchronizing with the motor speed in the reverse direction, reverse decelerating the motor through zero speed, changing direction, and accelerating in open loop in forward (or commanded) direction until the device transitions into closed loop in forward direction (see [Figure 7-23](#)).

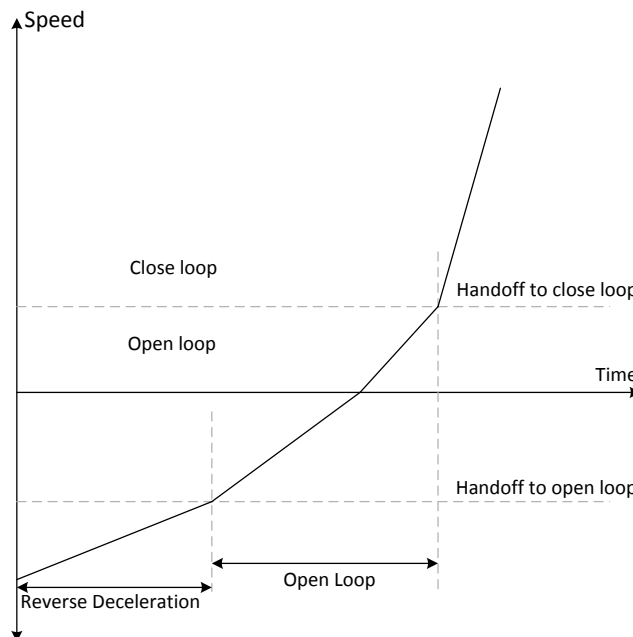

Figure 7-23. Reverse Drive Function

7.3.10.3.1 Reverse Drive Tuning

The speed at which motor would enter the open loop in reverse direction can be configured using REV_DRV_HANDOFF_THR. For a smooth transition without jerks or loss of synchronism, user can configure an appropriate current limit when the motor is spinning in open loop during speed reversal using REV_DRV_OPEN_LOOP_CURRENT. The open loop acceleration rate for the forward direction during speed reversal is defined using REV_DRV_OPEN_LOOP_ACCEL_A1. The reverse drive open loop deceleration rate, when the motor is decelerating in the opposite direction to zero speed, can be configured as a percentage of reverse drive open loop acceleration using REV_DRV_OPEN_LOOP_DEC.

7.3.10.4 Motor Start-up

There are different options available for motor start-up from a stationary position and these options can be configured by MTR_STARTUP. In align and double align mode, the motor is aligned to a known position by injecting a DC current. In IPD mode, the rotor position is estimated by applying 6 different high-frequency pulses. In slow first cycle mode, the motor is started by applying a low frequency cycle.

7.3.10.4.1 Align

Align is enabled by configuring MTR_STARTUP to 00b. The MCF8329HS aligns the motor by injecting a DC current through a particular phase pattern for a certain time configured by ALIGN_TIME. In the MCF8329HS, the current limit during align is configured through ALIGN_OR_SLOW_CURRENT_ILIMIT.

A fast change in the phase current can result in a sudden change in the driving torque and this can result in acoustic noise. To avoid this, the MCF8329HS ramps up the current from 0 to the current limit at a configurable ramp rate set by ALIGN_SLOW_RAMP_RATE. At the end of align routine the motor, is aligned at the known position.

7.3.10.4.2 Double Align

Double align is enabled by configuring MTR_STARTUP to 01b. Single align is not reliable when the initial position of the rotor is 180° out of phase with the applied phase pattern. In this case, having start-up failures using single align is possible. To improve the reliability of align based start-up, the MCF8329HS provides the option of double align start-up. In double align start-up, MCF8329HS uses a phase pattern for the second align that is 90° ahead of the first align phase pattern. In double align, relevant parameters like align time, current limit, ramp rate are the same as in the case of single align - two different phase patterns are applied in succession with the same parameters to maintain that the motor is aligned to a known position irrespective of initial rotor position.

7.3.10.4.3 Initial Position Detection (IPD)

Initial Position Detection (IPD) can be enabled by configuring MTR_STARTUP to 10b. In IPD, inductive sense method is used to determine the initial position of the motor using the spatial variation in the motor inductance.

Align or double align may result in the motor spinning in the reverse direction before starting open loop acceleration. IPD can be used in such applications where reverse rotation of the motor is unacceptable. IPD does not wait for the motor to align with the commutation and therefore can allow for a faster motor start-up sequence. IPD works well when the inductance of the motor varies as a function of position. IPD works by pulsing current in to the motor and hence can generate acoustics which must be taken into account when determining the best start-up method for a particular application.

7.3.10.4.3.1 IPD Operation

IPD operates by sequentially applying six different phase patterns according to the following sequence: BC-> CB-> AB-> BA-> CA-> AC (see [Figure 7-24](#)). When the current reaches the threshold configured by IPD_CURR_THR, the MCF8329HS stops driving the particular phase pattern and measures the time taken to reach the current threshold from when the particular phase pattern was applied. Thus, the time taken to reach IPD_CURR_THR is measured for all six phase patterns - this time varies as a function of the inductance in the motor windings. The state with the shortest time represents the state with the minimum inductance. The minimum inductance is because of the alignment of the north pole of the motor with this particular driving state.

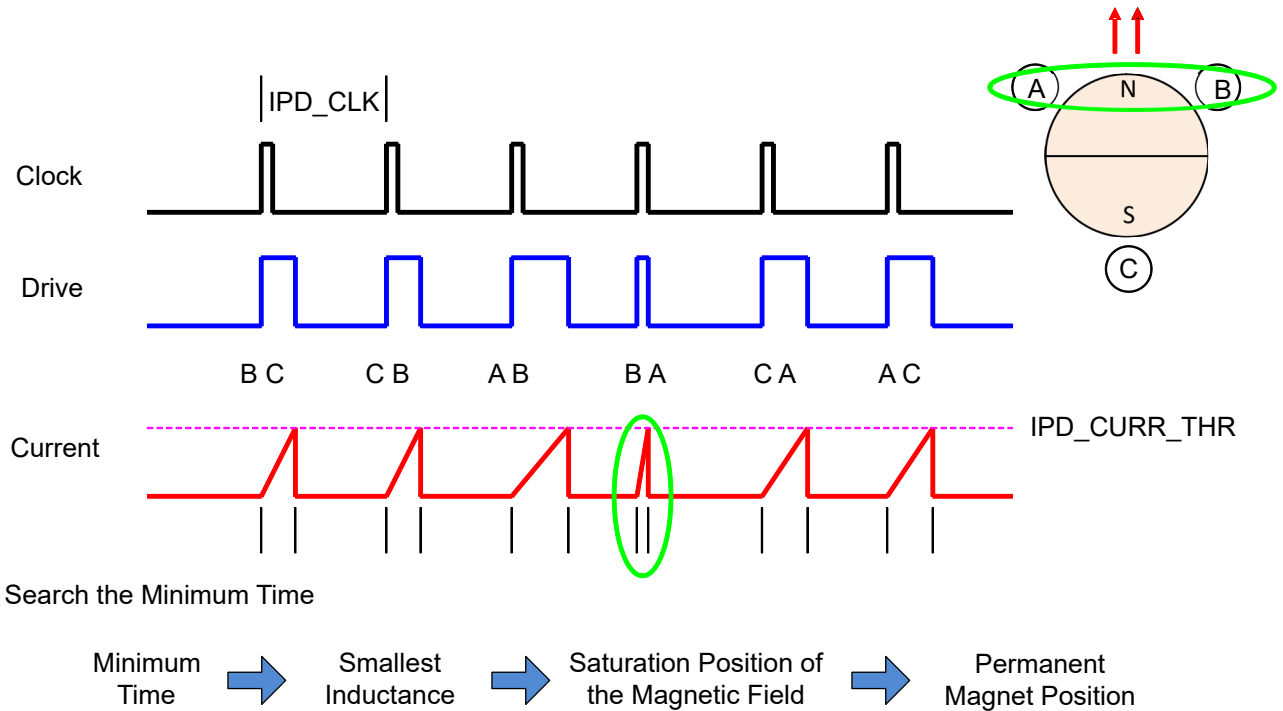

Figure 7-24. IPD Function

7.3.10.4.3.2 IPD Release

IPD release uses Hi-Z mode, both the high-side (HSA) and low-side (LSC) MOSFETs are turned OFF and the current recirculates through the body diodes back to the power supply (see Figure 7-25).

The Hi-Z mode during IPD release can result in a voltage increase on motor DC supply voltage VM (V_{PVDD}). The user must manage this with an appropriate selection of either a clamp circuit or by providing sufficient capacitance between V_{PVDD} and GND to absorb the energy.

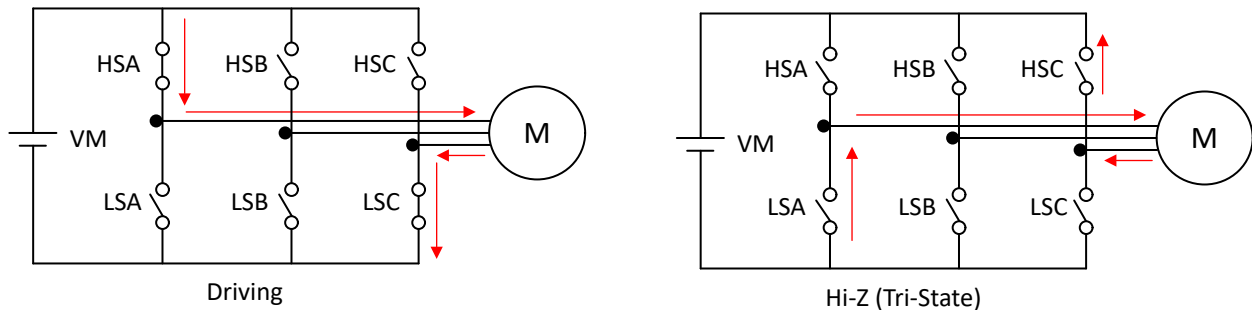

Figure 7-25. IPD Release Hi-Z mode

7.3.10.4.3.3 IPD Advance Angle

After the initial position is detected, the MCF8329HS begins driving the motor in open loop at an angle specified by IPD_ADV_ANGLE.

Advancing the drive angle anywhere from 0° to 180° results in positive torque. Advancing the drive angle by 90° results in maximum initial torque. Applying maximum initial torque could result in uneven acceleration to the rotor. Select the IPD_ADV_ANGLE to allow for smooth acceleration in the application (see Figure 7-26).

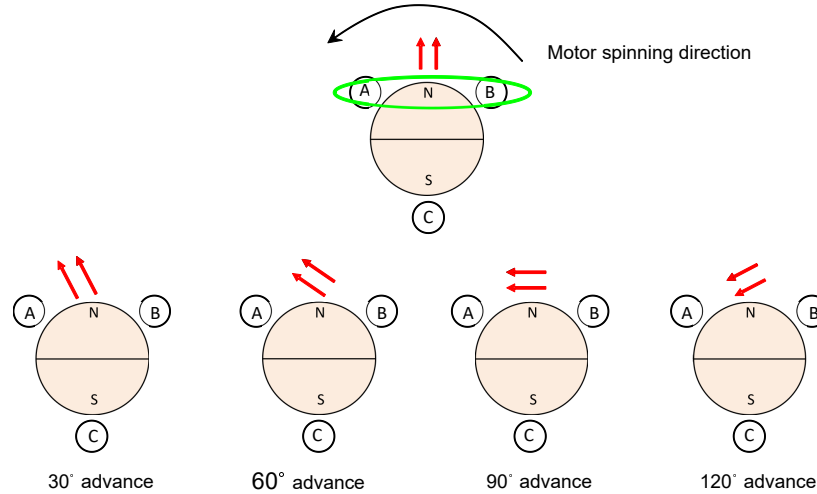

Figure 7-26. IPD Advance Angle

7.3.10.4.4 Slow First Cycle Startup

Slow First Cycle start-up is enabled by configuring MTR_STARTUP to 11b. In slow first cycle start-up, the MCF8329HS starts motor commutation at a frequency defined by SLOW_FIRST_CYC_FREQ. The frequency configured is used only for first cycle, and then the motor commutation follows acceleration profile configured by open loop acceleration coefficients A1 and A2. The slow first cycle frequency has to be configured to be slow enough to allow motor to synchronize with the commutation sequence. This mode is useful when fast startup is desired as it significantly reduces the align time.

7.3.10.4.5 Open Loop

Upon completing the motor position initialization with either align, double align, IPD or slow first cycle, the MCF8329HS begins to accelerate the motor in open loop. During open loop, the speed is increased with a fixed current limit. In open loop, the control PI loops for I_q and I_d actively control the currents. The angle during open loop is provided from the ramp generator as shown in Figure 7-27.

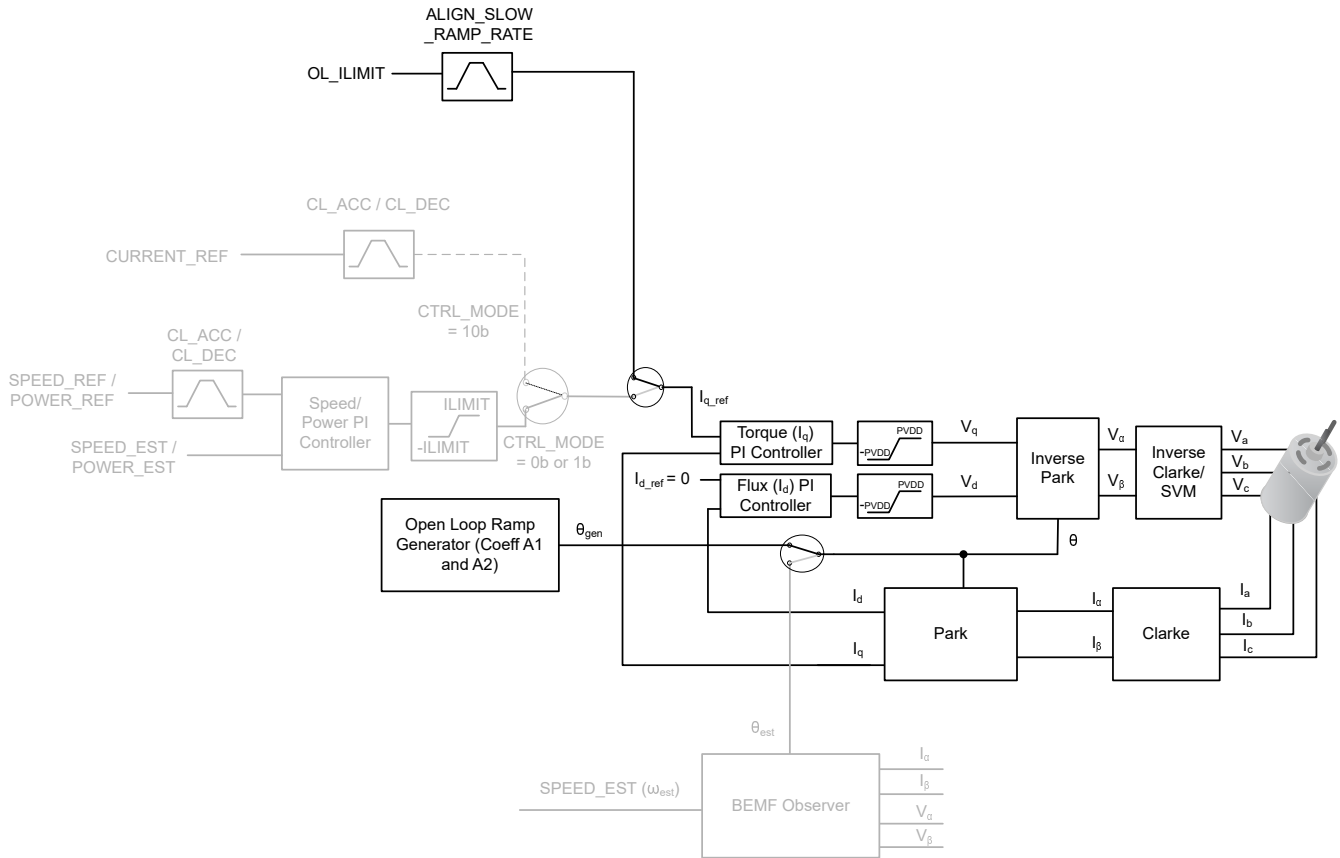

Figure 7-27. Open Loop

In MCF8329HS, the current limit threshold is configured through OL_ILIMIT. The function of the open-loop operation is to drive the motor to a speed at which the motor generates sufficient BEMF to allow the back-EMF observer to accurately detect the position of the rotor. The motor is accelerated in open loop and speed at any given time is determined by Equation 8. In MCF8329HS, open loop acceleration coefficients, A1 and A2 are configured through OL_ACC_A1 and OL_ACC_A2 respectively.

$$\text{Speed}(t) = A1 * t + 0.5 * A2 * t^2 \quad (8)$$

7.3.10.4.6 Transition from Open to Closed Loop

Once the motor has reached a sufficient speed for the back-EMF observer to estimate the angle and speed of the motor, the MCF8329HS transitions into closed loop state. This handoff speed is automatically determined based on the measured back-EMF and motor speed. Users also have an option to manually set the handoff speed by configuring OPN_CL_HANDOFF_THR and setting AUTO_HANDOFF_EN to 0b. In order to have smooth transition and avoid speed transients, the theta_error ($\Theta_{gen} - \Theta_{est}$) is decreased linearly after transition. The ramp rate of theta_error reduction can be configured using THETA_ERROR_RAMP_RATE. If the current limit set during the open loop is high and if it is not reduced before transition to closed loop, the motor speed may momentarily rise to higher values than SPEED_REF after transition into closed loop. In order to avoid such speed variations, configure the IQ_RAMP_DOWN_EN to 1b, so that i_{q_ref} decreases prior to transition into closed loop. However if the final speed reference (SPEED_REF) is more than two times the open loop to closed loop hand off speed (OPN_CL_HANDOFF_THR), then i_{q_ref} is not decreased independent of the IQ_RAMP_DOWN_EN setting, to enable faster motor acceleration.

After hand off to closed loop at a sufficient speed, there could be still some theta error, as the estimators may not be fully aligned. A slow acceleration can be used after the open loop to closed loop transition, ensuring that the theta error reduces to zero. The slow acceleration can be configured using CL_SLOW_ACC.

Figure 7-28 shows the control sequence in open to closed loop transition. The current i_{q_ref} reduces to a lower value in current decay region, if IQ_RAMP_DOWN_EN is set to 1b. If IQ_RAMP_DOWN_EN is set to 0b, then the current decay region will not be present in the transition sequence.

Note

Iq ramp down is available (irrespective of IQ_RAMP_DOWN_EN setting) only in speed control mode (CTRL_MODE = 00b)

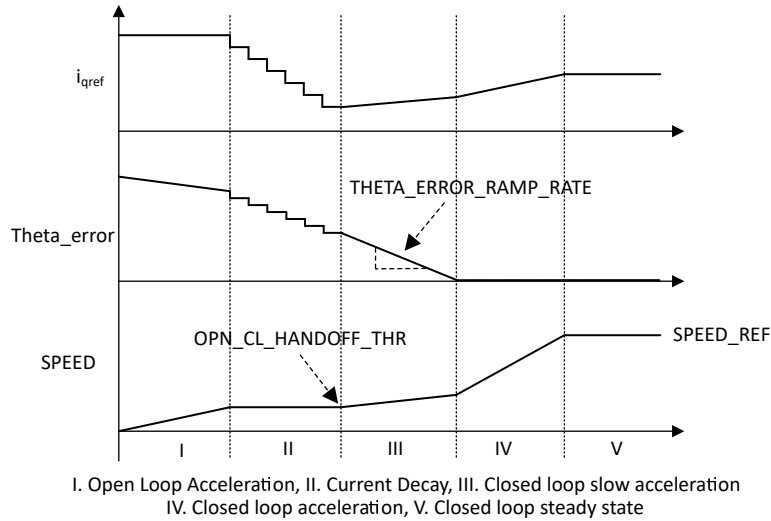

Figure 7-28. Control Sequence in Open to Closed Loop Transition

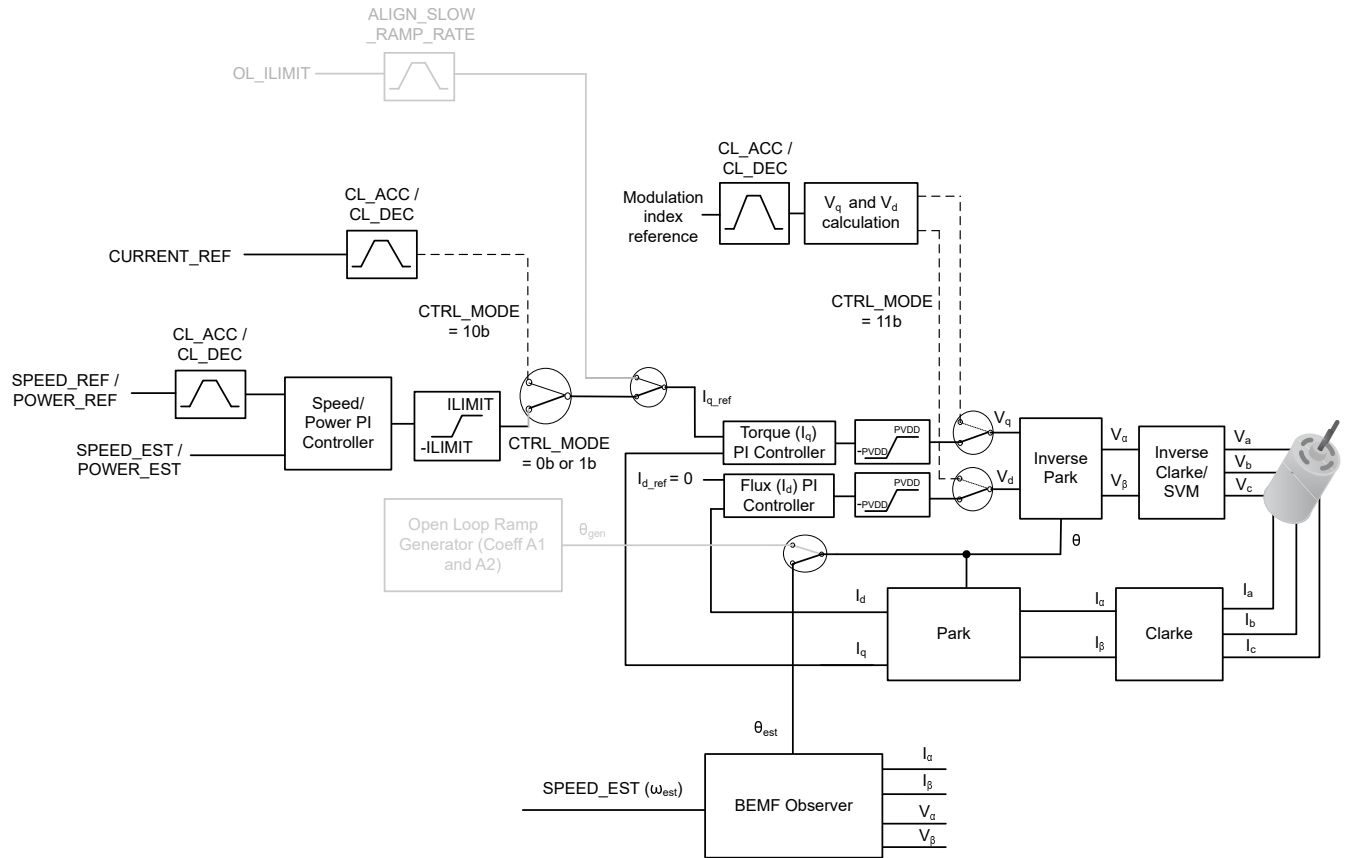

Figure 7-29. Open to Closed Loop Transition

7.3.11 Closed Loop Operation

The MCF8329HS drives the motor using Field Oriented Control (FOC) as shown in Figure 7-30. In closed loop operation, the motor angle (θ_{est}) and speed (ω_{est}) are estimated using the back-EMF observer. The speed and current regulation are achieved using PI control loop. To achieve maximum efficiency, the direct axis current is set to zero ($I_{d_ref} = 0$), which maintains that stator and rotor field are orthogonal (90° out of phase) to each other. If flux weakening or MTPA is enabled I_{d_ref} can be zero or a negative value during closed loop operation.

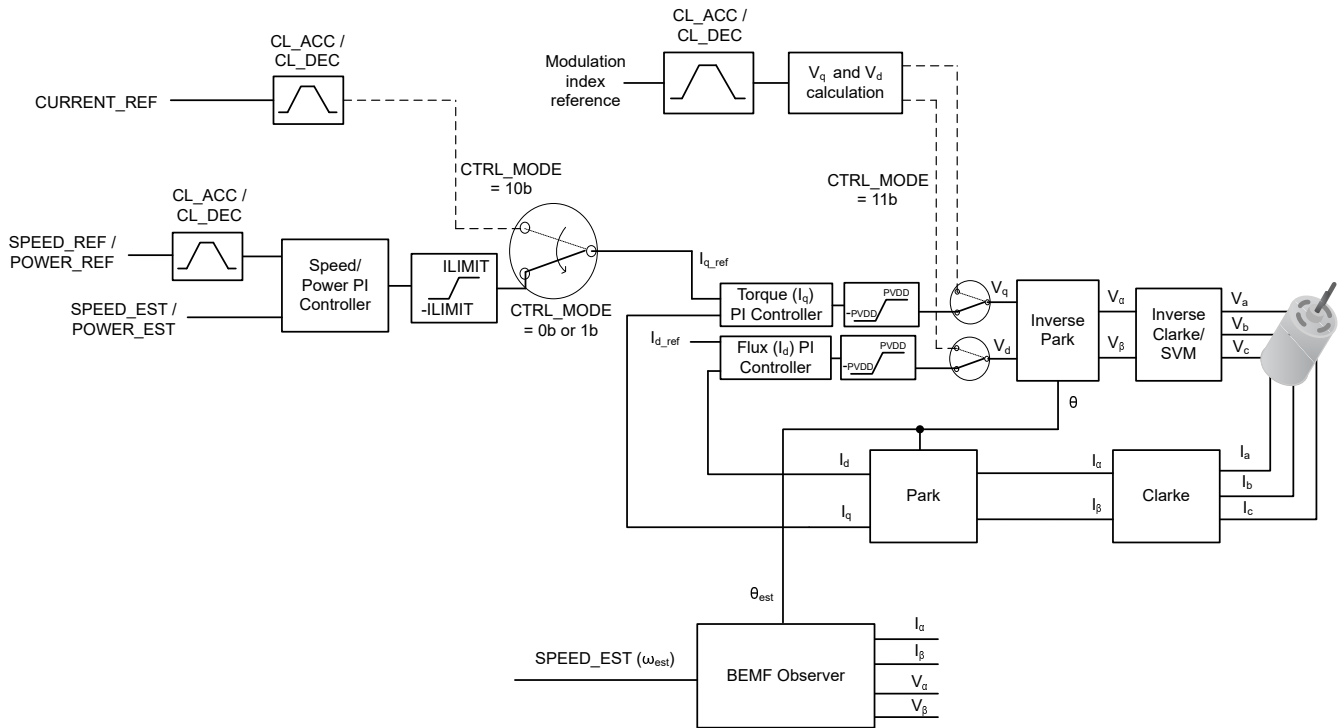

Figure 7-30. Closed Loop FOC Control

7.3.11.1 Closed loop accelerate

During closed loop acceleration/deceleration, MCF8329HS provides the option of configuring the slew rate of the reference input. This allows for a linear change in reference input (speed or power or current or modulation index) even when there is a step change in reference input (from Analog, PWM, Frequency or I²C) as seen in [Figure 7-31](#). This slew rate can be configured so as to prevent sudden changes in the torque applied to the motor which can result in acoustic noise. The closed loop acceleration/deceleration slew rate parameter, CL_ACC/CL_DEC, sets the slew rate of the reference during acceleration and deceleration (when AVS is not active) respectively.

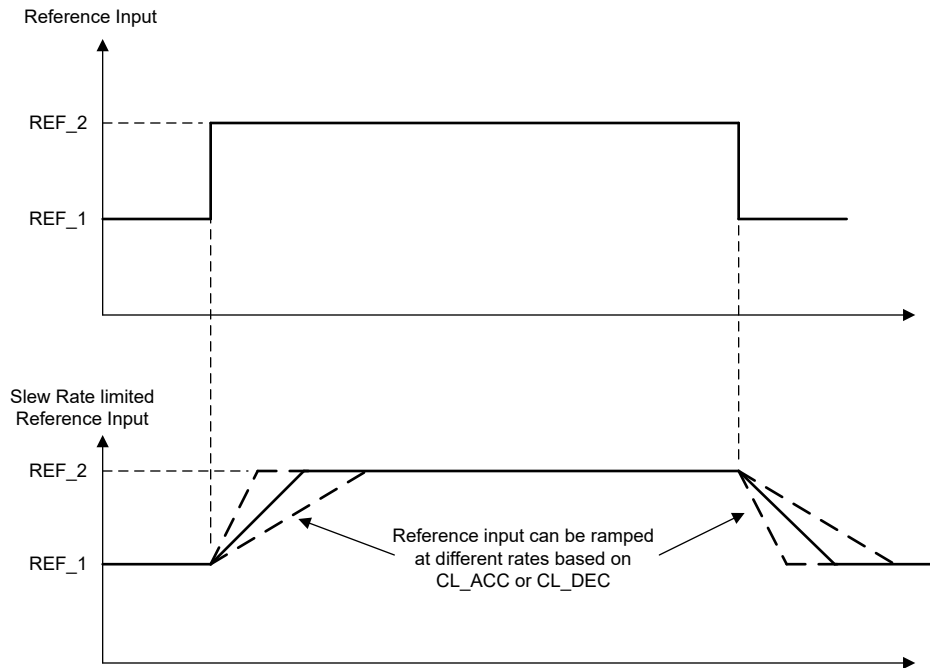

Figure 7-31. Closed Loop Acceleration/Deceleration Slew Rate

7.3.11.2 Speed PI Control

The integrated speed control loop helps maintain a constant speed over varying operating conditions. The K_p and K_i coefficients are configured through SPD_LOOP_KP and SPD_LOOP_KI. The output of the speed loop is used to generate the current reference for torque control (I_{q_ref}). The output of the speed loop is limited to implement a current limit. The current limit is set by configuring ILIMIT. When output of the speed loop saturates, the integrator is disabled to prevent integral wind-up.

SPEED_REF_SLEW is derived from the duty command input, reference (speed) profiles and closed loop acceleration/deceleration rates configured by the user and SPEED_EST is the estimated speed from the back-EMF observer.

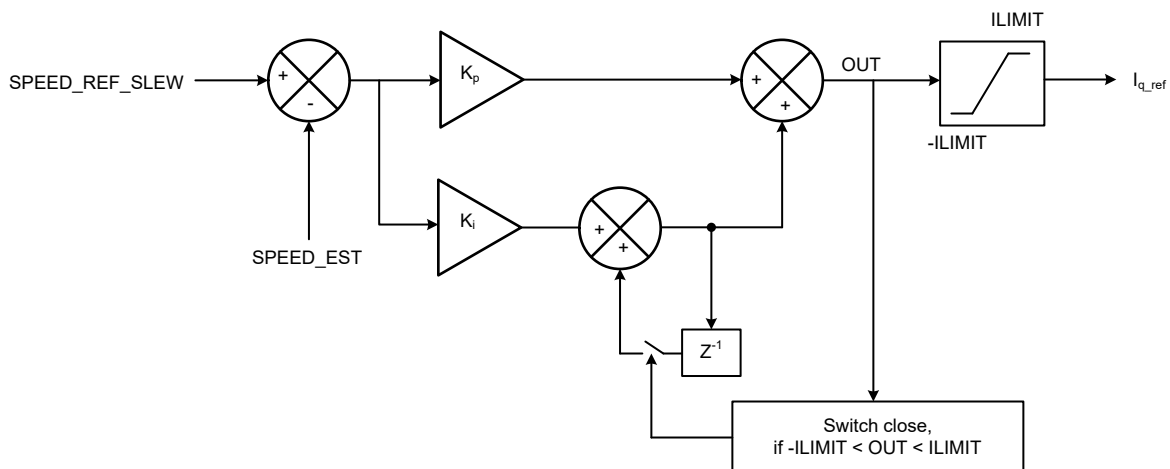

Figure 7-32. Speed PI Control

7.3.11.3 Current PI Control

The MCF8329HS has two PI controllers, one each for I_d and I_q to control flux and torque separately. K_p and K_i coefficients are the same for both PI controllers and are configured through CURR_LOOP_KP and

CURR_LOOP_KI. The outputs of the current control loops are used to generate voltage signals V_d and V_q to be applied to the motor. The outputs of the current loops are clamped to supply voltage, PVDD. I_d current PI loop is executed first and output of I_d current PI loop V_d is checked for saturation. When the output of the current loop saturates, the integration is disabled to prevent integral wind-up.

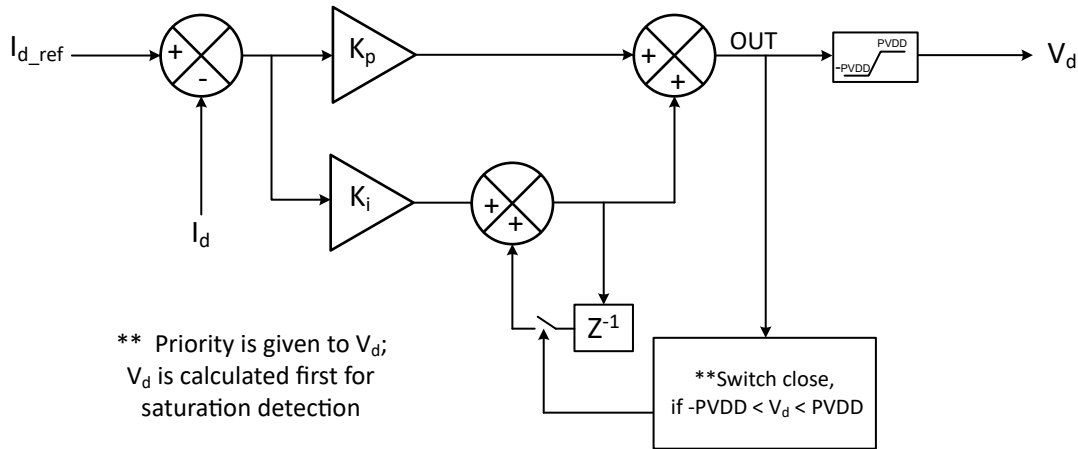

Figure 7-33. I_d Current PI Control

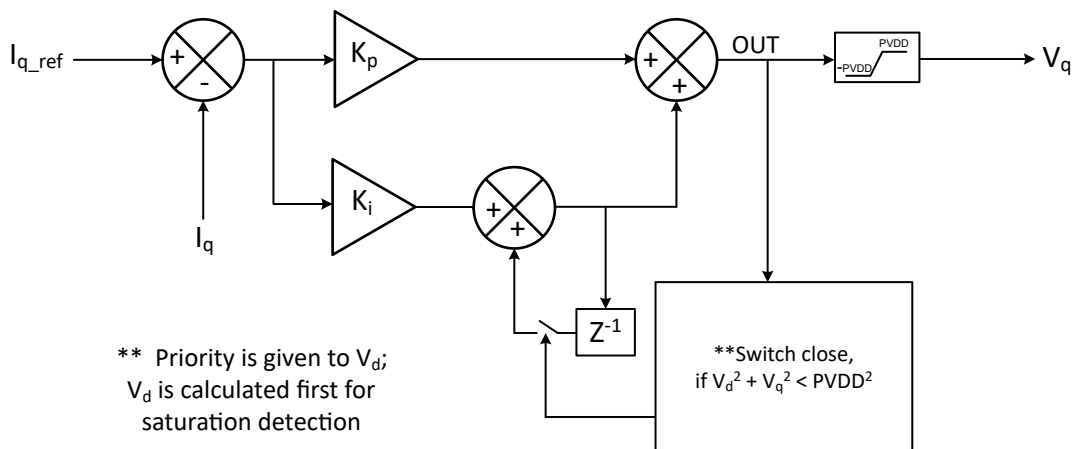

Figure 7-34. I_q Current PI Control

7.3.11.4 Overmodulation

MCF8329HS provides overmodulation to operate the motor at a higher speed at the same PVDD voltage by increasing the applied fundamental phase voltage by suitably modifying the applied PWM pattern. This feature can be enabled by setting OVERMODULATION_ENABLE to 1b.

7.3.11.5 Power Loop

MCF8329HS provides an option of regulating the (input DC) power instead of motor speed for a closed loop power control. Input power regulation (instead of motor speed) mode is selected by setting CTRL_MODE to 01b. The maximum power that MCF8329HS can draw from the DC input supply is set by MAX_POWER. The K_p and K_i coefficients for power loop are configured through SPD_LOOP_KP and SPD_LOOP_KI.

$$POWER REF(W) = DUTY CMD \times Maximum Power (W) \quad (9)$$

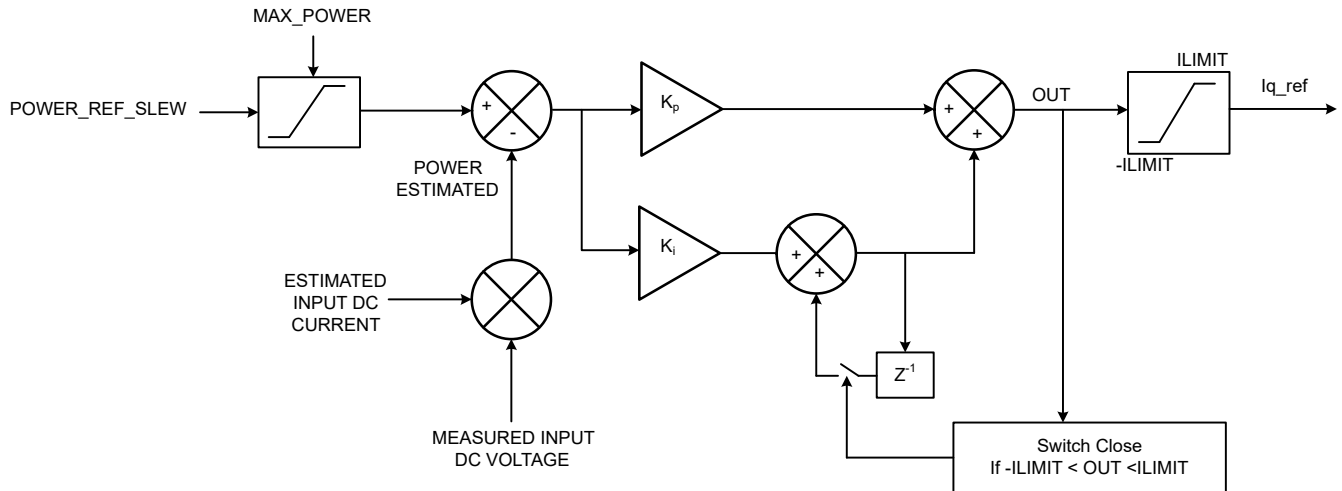

Figure 7-35. Closed Loop Power Control

7.3.11.6 Modulation Index Control

MCF8329HS provides voltage control mode, selected by setting CTRL_MODE to 11b. The closed loop speed control, power control and current control (i_q and i_d) are disabled in this mode. The applied V_q and V_d are controlled directly using the user defined modulation index reference voltage (VOLTAGE REF) and the lead angle setting. The VOLTAGE REF varies from MIN_DUTY to 100%.

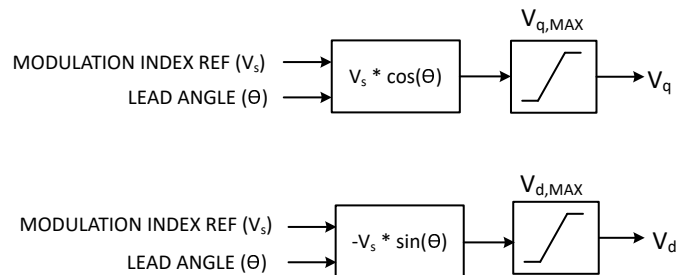

Figure 7-36. Open Loop Voltage Control

Note

1. The maximum modulation index (V_s) supported in modulation control mode depends on DIG_DEAD_TIME, SINGLE_SHUNT_BLANKING_TIME, and PWM_FREQ_OUT settings.

7.3.11.7 Motor Speed Limit

MCF8329HS provides the option of limiting the motor speed to a user configured limit. When SPEED_LIMIT_ENABLE is set to 1b, irrespective of the input reference mode (current, power or voltage) and operating conditions like (VM, load), MCF8329HS limits the motor speed to MAX_SPEED by restricting the input DC power, motor phase current or voltage (depending on input reference mode). When speed limit is active (motor speed limited at MAX_SPEED), the acceleration/deceleration rate is set by CL_SLOW_ACC instead of CL_ACC/CL_DEC to minimize chattering around the MAX_SPEED value. When the speed limit condition becomes inactive (motor speed < MAX_SPEED), acceleration/deceleration rate reverts to CL_ACC/CL_DEC.

7.3.11.8 Input DC Power Limit

MCF8329HS provides the option of limiting the power that the motor driver can draw from the input DC source (VM). When BUS_POWER_LIMIT_ENABLE is set to 1b, irrespective of the input reference mode (speed, current, or voltage) and operating conditions like (VM, load), MCF8329HS limits the input DC power to MAX_POWER by restricting the motor speed, current or voltage (depending on input reference mode). When

power limit is active (input DC power limited at MAX_POWER), the acceleration/deceleration rate is set by CL_SLOW_ACC instead of CL_ACC/CL_DEC to minimize chattering around the MAX_POWER value. When the power limit condition becomes inactive (input DC power < MAX_POWER), acceleration/deceleration rate reverts to CL_ACC/CL_DEC.

7.3.12 Maximum Torque Per Ampere (MTPA) Control

PMSM or BLDC motors with magnetic saliency produces a reluctance torque from the difference between the direct-d axis inductance and the quadrature q-axis inductance. The maximum efficiency of the IPM motors can be achieved by proper selection of the current vector ratio between magnetic torque current and reluctance torque current in the total current. MCF8329HS provides the maximum torque per ampere control and in that, for a given bus current, it is possible to obtain the best torque performance by setting the d axis current reference as a function of the q axis current reference as per the equation below.

$$i_{d_MTPA} = \frac{\psi_m}{2(L_q - L_d)} \left(1 - \sqrt{1 + \frac{4(L_q - L_d)^2 i_q^2}{\psi_m^2}} \right) \quad (10)$$

Ld and Lq are inductance of the d and q axis respectively. iq is the Q-axis current and ψm is the BEMF constant. In case of motors without saliency in the rotor, the inductances of d and q axis are the same and hence the point of maximum torque is always the one where d-axis current reference is 0. For motors with saliency, the d-axis reference can be set as a function of the q-axis reference as derived in the equation above so as to generate the maximum torque for any current drawn from the DC bus.

7.3.13 Flux Weakening Control

PMSM motors can be operated not only in the constant torque region below the base speed (normally rated speed) but also in the constant power region above the base speed, but the base speed can be varied according to current and voltage limitation. MCF8329HS provides a flux weakening control, to increase the speed beyond the motor rated speed. The flux weakening can be enabled by setting 1b to FLUX_WEAKENING_EN. The flux weakening control uses a PI control loop as shown in [Figure 7-37](#), to create the Idref. Kp and Ki coefficients for flux weakening loop are configured through FLUX_WEAKENING_KP and FLUX_WEAKENING_KI.

The absolute maximum value of flux weakening current reference (Id_FW) can be limited as a percentage of ILIMIT by configuring FLUX_WEAKENING_CURRENT_RATIO. If FLUX_WEAKENING_CURRENT_RATIO = 0b, then only circular limit is in place, in that case iq² + id² is limited to ILIMIT. If Id_FW absolute value increases then iq is reduced to meet circular limit.

User can configure the modulation index reference, Vs_ref (shown in [Equation 11](#)) below that the flux weakening is not active and Id_FW is made to zero. The configuration is available in the bits FLUX_WEAKENING_REFERENCE.

$$V_{s_ref} = \sqrt{V_{q_ref}^2 + V_{d_ref}^2} \quad (11)$$

The Idref can be zero or minimum of id reference from flux weakening or MTPA.

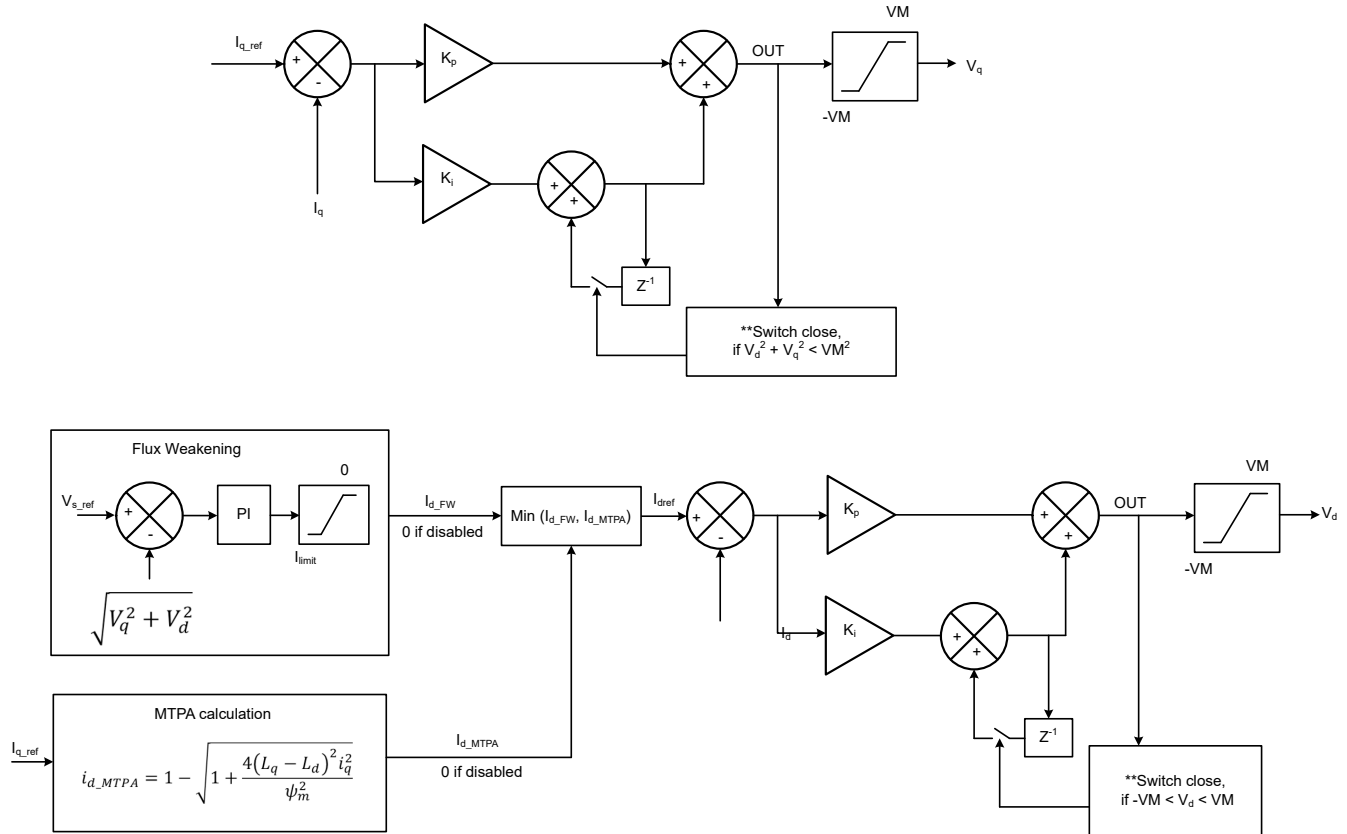

Figure 7-37. Flux Weakening Control

7.3.14 Motor Parameters

The MCF8329HS uses the motor resistance, motor inductance and motor back-EMF constant to estimate motor position when operating in closed loop. The MCF8329HS has the capability of measuring back-EMF constant in the offline state (see [Motor Parameter Extraction Tool \(MPET\)](#)). Offline measurement of back-EMF constant, when enabled, takes place before normal motor operation. The user can also disable the offline measurement and configure motor parameters through EEPROM.

7.3.14.1 Motor Resistance

For a wye-connected motor, the motor phase resistance refers to the resistance from the phase output to the center tap, R_{PH} (denoted as R_{PH} in [Table 7-2](#)). For a delta-connected motor, the motor phase resistance refers to the equivalent phase to center tap in the wye configuration in [Table 7-2](#).

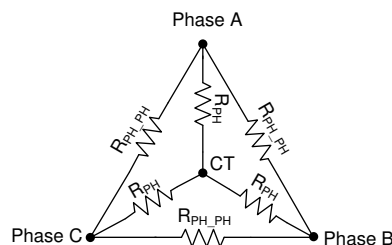

Figure 7-38. Motor Resistance

For both the delta-connected and the wye-connected motor, the easy way to get the equivalent R_{PH} is to measure the resistance between two phase terminals (R_{PH_PH}), and then divide this value by two, $R_{PH} = \frac{1}{2} R_{PH_PH}$. In wye-connected motor, if user has access to center tap (CT), R_{PH} can also be measured between center tap (CT) and phase terminal.

Configure the motor resistance (R_{PH}) to a nearest value from [Table 7-2](#).

Table 7-2. Motor Resistance Look-Up Table

MOTOR_RES (HEX)	R_{PH} (Ω)	MOTOR_RES (HEX)	R_{PH} (Ω)	MOTOR_RES (HEX)	R_{PH} (Ω)	MOTOR_RES (HEX)	R_{PH} (Ω)
0x00	Reserved	0x40	0.017	0x80	0.17	0xC0	1.7
0x01	0.001	0x41	0.0175	0x81	0.175	0xC1	1.75
0x02	0.0011	0x42	0.018	0x82	0.18	0xC2	1.8
0x03	0.0012	0x43	0.0185	0x83	0.185	0xC3	1.85
0x04	0.0013	0x44	0.019	0x84	0.19	0xC4	1.9
0x05	0.0014	0x45	0.0195	0x85	0.195	0xC5	1.95
0x06	0.0015	0x46	0.02	0x86	0.2	0xC6	2
0x07	0.0016	0x47	0.021	0x87	0.21	0xC7	2.1
0x08	0.0017	0x48	0.022	0x88	0.22	0xC8	2.2
0x09	0.0018	0x49	0.023	0x89	0.23	0xC9	2.3
0x0A	0.0019	0x4A	0.024	0x8A	0.24	0xCA	2.4
0x0B	0.002	0x4B	0.025	0x8B	0.25	0xCB	2.5
0x0C	0.0021	0x4C	0.026	0x8C	0.26	0xCC	2.6
0x0D	0.0022	0x4D	0.027	0x8D	0.27	0xCD	2.7
0x0E	0.0023	0x4E	0.028	0x8E	0.28	0xCE	2.8
0x0F	0.0024	0x4F	0.029	0x8F	0.29	0xCF	2.9
0x10	0.0025	0x50	0.03	0x90	0.3	0xD0	3
0x11	0.0026	0x51	0.031	0x91	0.31	0xD1	3.1
0x12	0.0027	0x52	0.032	0x92	0.32	0xD2	3.2
0x13	0.0028	0x53	0.033	0x93	0.33	0xD3	3.3
0x14	0.0029	0x54	0.034	0x94	0.34	0xD4	3.4
0x15	0.003	0x55	0.035	0x95	0.35	0xD5	3.5
0x16	0.0032	0x56	0.036	0x96	0.36	0xD6	3.6
0x17	0.0034	0x57	0.037	0x97	0.37	0xD7	3.7
0x18	0.0036	0x58	0.038	0x98	0.38	0xD8	3.8
0x19	0.0038	0x59	0.039	0x99	0.39	0xD9	3.9
0x1A	0.004	0x5A	0.04	0x9A	0.4	0xDA	4
0x1B	0.0042	0x5B	0.042	0x9B	0.42	0xDB	4.25
0x1C	0.0044	0x5C	0.044	0x9C	0.44	0xDC	4.5
0x1D	0.0046	0x5D	0.046	0x9D	0.46	0xDD	4.75
0x1E	0.0048	0x5E	0.048	0x9E	0.48	0xDE	5
0x1F	0.005	0x5F	0.05	0x9F	0.5	0xDF	5.25
0x20	0.0052	0x60	0.052	0xA0	0.52	0xE0	5.5
0x21	0.0054	0x61	0.054	0xA1	0.54	0xE1	5.75
0x22	0.0056	0x62	0.056	0xA2	0.56	0xE2	6
0x23	0.0058	0x63	0.058	0xA3	0.58	0xE3	6.25
0x24	0.006	0x64	0.06	0xA4	0.6	0xE4	6.5
0x25	0.0062	0x65	0.062	0xA5	0.62	0xE5	7
0x26	0.0064	0x66	0.064	0xA6	0.64	0xE6	7.5
0x27	0.0066	0x67	0.066	0xA7	0.66	0xE7	8
0x28	0.0068	0x68	0.068	0xA8	0.68	0xE8	8.5
0x29	0.007	0x69	0.07	0xA9	0.7	0xE9	9
0x2A	0.0072	0x6A	0.072	0xAA	0.72	0xEA	9.5

Table 7-2. Motor Resistance Look-Up Table (continued)

MOTOR_RES (HEX)	R _{PH} (Ω)	MOTOR_RES (HEX)	R _{PH} (Ω)	MOTOR_RES (HEX)	R _{PH} (Ω)	MOTOR_RES (HEX)	R _{PH} (Ω)
0x2B	0.0074	0x6B	0.074	0xAB	0.74	0xEB	10
0x2C	0.0076	0x6C	0.076	0xAC	0.76	0xEC	10.5
0x2D	0.0078	0x6D	0.078	0xAD	0.78	0xED	11
0x2E	0.008	0x6E	0.08	0xAE	0.8	0xEE	11.5
0x2F	0.0085	0x6F	0.085	0xAF	0.82	0xEF	12
0x30	0.009	0x70	0.09	0xB0	0.9	0xF0	12.5
0x31	0.0095	0x71	0.095	0xB1	0.95	0xF1	13
0x32	0.01	0x72	0.1	0xB2	1	0xF2	13.5
0x33	0.0105	0x73	0.105	0xB3	1.05	0xF3	14
0x34	0.011	0x74	0.11	0xB4	1.1	0xF4	14.5
0x35	0.0115	0x75	0.115	0xB5	1.15	0xF5	15
0x36	0.012	0x76	0.12	0xB6	1.2	0xF6	15.5
0x37	0.0125	0x77	0.125	0xB7	1.25	0xF7	16
0x38	0.013	0x78	0.13	0xB8	1.3	0xF8	16.5
0x39	0.0135	0x79	0.135	0xB9	1.35	0xF9	17
0x3A	0.014	0x7A	0.14	0xBA	1.4	0xFA	17.5
0x3B	0.0145	0x7B	0.145	0xBB	1.45	0xFB	18
0x3C	0.015	0x7C	0.15	0xBC	1.5	0xFC	18.5
0x3D	0.0155	0x7D	0.155	0xBD	1.55	0xFD	19
0x3E	0.016	0x7E	0.16	0xBE	1.6	0xFE	19.5
0x3F	0.0165	0x7F	0.165	0xBF	1.65	0xFF	20

7.3.14.2 Motor Inductance

For a wye-connected motor, the motor phase inductance refers to the inductance from the phase output to the center tap, L_{PH} (denoted as L_{PH} in Table 7-3). For a delta-connected motor, the motor phase inductance refers to the equivalent phase to center tap in the wye configuration in Table 7-3.

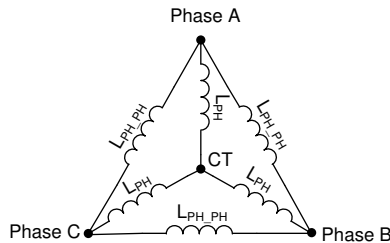

Figure 7-39. Motor Inductance

For both the delta-connected motor and the wye-connected motor, the easy way to get the equivalent L_{PH} is to measure the inductance between two phase terminals (L_{PH_PH}), and then divide this value by two, L_{PH} = ½ L_{PH_PH}. In wye-connected motor, if user has access to center tap (CT), L_{PH} can also be measured between center tap (CT) and phase terminal.

Configure the motor inductance (L_{PH}) to a nearest value from Table 7-3.

Table 7-3. Motor Inductance Look-Up Table

MOTOR_IND (HEX)	L _{PH} (mH)	MOTOR_IND (HEX)	L _{PH} (mH)	MOTOR_IND (HEX)	L _{PH} (mH)	MOTOR_IND (HEX)	L _{PH} (mH)
0x00	Reserved	0x40	0.017	0x80	0.17	0xC0	1.7
0x01	0.001	0x41	0.0175	0x81	0.175	0xC1	1.75

Table 7-3. Motor Inductance Look-Up Table (continued)

MOTOR_IND (HEX)	L _{PH} (mH)	MOTOR_IND (HEX)	L _{PH} (mH)	MOTOR_IND (HEX)	L _{PH} (mH)	MOTOR_IND (HEX)	L _{PH} (mH)
0x02	0.0011	0x42	0.018	0x82	0.18	0xC2	1.8
0x03	0.0012	0x43	0.0185	0x83	0.185	0xC3	1.85
0x04	0.0013	0x44	0.019	0x84	0.19	0xC4	1.9
0x05	0.0014	0x45	0.0195	0x85	0.195	0xC5	1.95
0x06	0.0015	0x46	0.02	0x86	0.2	0xC6	2
0x07	0.0016	0x47	0.021	0x87	0.21	0xC7	2.1
0x08	0.0017	0x48	0.022	0x88	0.22	0xC8	2.2
0x09	0.0018	0x49	0.023	0x89	0.23	0xC9	2.3
0x0A	0.0019	0x4A	0.024	0x8A	0.24	0xCA	2.4
0x0B	0.002	0x4B	0.025	0x8B	0.25	0xCB	2.5
0x0C	0.0021	0x4C	0.026	0x8C	0.26	0xCC	2.6
0x0D	0.0022	0x4D	0.027	0x8D	0.27	0xCD	2.7
0x0E	0.0023	0x4E	0.028	0x8E	0.28	0xCE	2.8
0x0F	0.0024	0x4F	0.029	0x8F	0.29	0xCF	2.9
0x10	0.0025	0x50	0.03	0x90	0.3	0xD0	3
0x11	0.0026	0x51	0.031	0x91	0.31	0xD1	3.1
0x12	0.0027	0x52	0.032	0x92	0.32	0xD2	3.2
0x13	0.0028	0x53	0.033	0x93	0.33	0xD3	3.3
0x14	0.0029	0x54	0.034	0x94	0.34	0xD4	3.4
0x15	0.003	0x55	0.035	0x95	0.35	0xD5	3.5
0x16	0.0032	0x56	0.036	0x96	0.36	0xD6	3.6
0x17	0.0034	0x57	0.037	0x97	0.37	0xD7	3.7
0x18	0.0036	0x58	0.038	0x98	0.38	0xD8	3.8
0x19	0.0038	0x59	0.039	0x99	0.39	0xD9	3.9
0x1A	0.004	0x5A	0.04	0x9A	0.4	0xDA	4
0x1B	0.0042	0x5B	0.042	0x9B	0.42	0xDB	4.25
0x1C	0.0044	0x5C	0.044	0x9C	0.44	0xDC	4.5
0x1D	0.0046	0x5D	0.046	0x9D	0.46	0xDD	4.75
0x1E	0.0048	0x5E	0.048	0x9E	0.48	0xDE	5
0x1F	0.005	0x5F	0.05	0x9F	0.5	0xDF	5.25
0x20	0.0052	0x60	0.052	0xA0	0.52	0xE0	5.5
0x21	0.0054	0x61	0.054	0xA1	0.54	0xE1	5.75
0x22	0.0056	0x62	0.056	0xA2	0.56	0xE2	6
0x23	0.0058	0x63	0.058	0xA3	0.58	0xE3	6.25
0x24	0.006	0x64	0.06	0xA4	0.6	0xE4	6.5
0x25	0.0062	0x65	0.062	0xA5	0.62	0xE5	7
0x26	0.0064	0x66	0.064	0xA6	0.64	0xE6	7.5
0x27	0.0066	0x67	0.066	0xA7	0.66	0xE7	8
0x28	0.0068	0x68	0.068	0xA8	0.68	0xE8	8.5
0x29	0.007	0x69	0.07	0xA9	0.7	0xE9	9
0x2A	0.0072	0x6A	0.072	0xAA	0.72	0xEA	9.5
0x2B	0.0074	0x6B	0.074	0xAB	0.74	0xEB	10
0x2C	0.0076	0x6C	0.076	0xAC	0.76	0xEC	10.5
0x2D	0.0078	0x6D	0.078	0xAD	0.78	0xED	11

Table 7-3. Motor Inductance Look-Up Table (continued)

MOTOR_IND (HEX)	L _{PH} (mH)	MOTOR_IND (HEX)	L _{PH} (mH)	MOTOR_IND (HEX)	L _{PH} (mH)	MOTOR_IND (HEX)	L _{PH} (mH)
0x2E	0.008	0x6E	0.08	0xAE	0.8	0xEE	11.5
0x2F	0.0085	0x6F	0.085	0xAF	0.82	0xEF	12
0x30	0.009	0x70	0.09	0xB0	0.9	0xF0	12.5
0x31	0.0095	0x71	0.095	0xB1	0.95	0xF1	13
0x32	0.01	0x72	0.1	0xB2	1	0xF2	13.5
0x33	0.0105	0x73	0.105	0xB3	1.05	0xF3	14
0x34	0.011	0x74	0.11	0xB4	1.1	0xF4	14.5
0x35	0.0115	0x75	0.115	0xB5	1.15	0xF5	15
0x36	0.012	0x76	0.12	0xB6	1.2	0xF6	15.5
0x37	0.0125	0x77	0.125	0xB7	1.25	0xF7	16
0x38	0.013	0x78	0.13	0xB8	1.3	0xF8	16.5
0x39	0.0135	0x79	0.135	0xB9	1.35	0xF9	17
0x3A	0.014	0x7A	0.14	0xBA	1.4	0xFA	17.5
0x3B	0.0145	0x7B	0.145	0xBB	1.45	0xFB	18
0x3C	0.015	0x7C	0.15	0xBC	1.5	0xFC	18.5
0x3D	0.0155	0x7D	0.155	0xBD	1.55	0xFD	19
0x3E	0.016	0x7E	0.16	0xBE	1.6	0xFE	19.5
0x3F	0.0165	0x7F	0.165	0xBF	1.65	0xFF	20

7.3.14.3 Motor Back-EMF constant

The back-EMF constant describes the motor phase-to-neutral back-EMF voltage as a function of the motor speed. For a wye-connected motor, the motor BEMF constant refers to the BEMF as a function of time from the phase output to the center tap, $K_{t_{PH_N}}$ (denoted as $K_{t_{PH_N}}$ in Table 7-4). For a delta-connected motor, the motor BEMF constant refers to the equivalent phase to center tap in the wye configuration in Table 7-4.

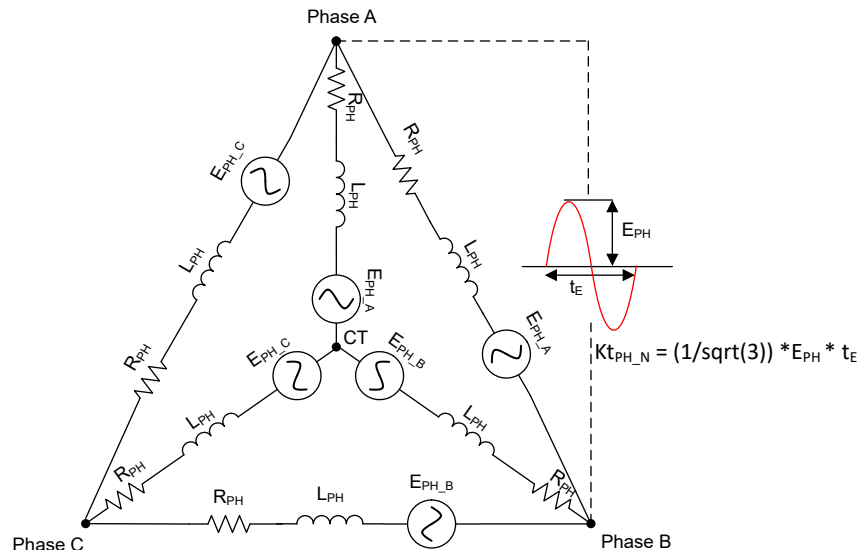

Figure 7-40. Motor back-EMF constant

For both the delta-connected motor and the wye-connected motor, the easy way to get the equivalent $K_{t_{PH_N}}$ is to measure the peak value of BEMF on scope for one electrical cycle between two phase terminals (E_{PH}), and then multiply by time duration of one electrical cycle and in order to convert from phase-to-phase to phase-to-neutral divide by $\sqrt{3}$ as shown in Equation 12.

$$Kt_{PH_N} = \frac{1}{\sqrt{3}} \times E_{PH} \times t_E \tag{12}$$

Configure the motor BEMF constant (Kt_{PH_N}) to a nearest value from [Table 7-4](#).

Table 7-4. Motor BEMF Constant Look-Up Table

MOTOR_BEMF_CONST (HEX)	Kt_{PH_N} (mV/Hz)	MOTOR_BEMF_CONST (HEX)	Kt_{PH_N} (mV/Hz)	MOTOR_BEMF_CONST (HEX)	Kt_{PH_N} (mV/Hz)	MOTOR_BEMF_CONST (HEX)	Kt_{PH_N} (mV/Hz)
0x00	Self Measurement (see Section 7.3.15)	0x40	1.7	0x80	17	0xC0	170
0x01	0.1	0x41	1.75	0x81	17.5	0xC1	175
0x02	0.11	0x42	1.8	0x82	18	0xC2	180
0x03	0.12	0x43	1.85	0x83	18.5	0xC3	185
0x04	0.13	0x44	1.9	0x84	19	0xC4	190
0x05	0.14	0x45	1.95	0x85	19.5	0xC5	195
0x06	0.15	0x46	2	0x86	20	0xC6	200
0x07	0.16	0x47	2.1	0x87	21	0xC7	210
0x08	0.17	0x48	2.2	0x88	22	0xC8	220
0x09	0.18	0x49	2.3	0x89	23	0xC9	230
0x0A	0.19	0x4A	2.4	0x8A	24	0xCA	240
0x0B	0.2	0x4B	2.5	0x8B	25	0xCB	250
0x0C	0.21	0x4C	2.6	0x8C	26	0xCC	260
0x0D	0.22	0x4D	2.7	0x8D	27	0xCD	270
0x0E	0.23	0x4E	2.8	0x8E	28	0xCE	280
0x0F	0.24	0x4F	2.9	0x8F	29	0xCF	290
0x10	0.25	0x50	3	0x90	30	0xD0	300
0x11	0.26	0x51	3.1	0x91	31	0xD1	310
0x12	0.27	0x52	3.2	0x92	32	0xD2	320
0x13	0.28	0x53	3.3	0x93	33	0xD3	330
0x14	0.29	0x54	3.4	0x94	34	0xD4	340
0x15	0.3	0x55	3.5	0x95	35	0xD5	350
0x16	0.32	0x56	3.6	0x96	36	0xD6	360
0x17	0.34	0x57	3.7	0x97	37	0xD7	370
0x18	0.36	0x58	3.8	0x98	38	0xD8	380
0x19	0.38	0x59	3.9	0x99	39	0xD9	390
0x1A	0.4	0x5A	4	0x9A	40	0xDA	400
0x1B	0.42	0x5B	4.2	0x9B	42	0xDB	425
0x1C	0.44	0x5C	4.4	0x9C	44	0xDC	450
0x1D	0.46	0x5D	4.6	0x9D	46	0xDD	475
0x1E	0.48	0x5E	4.8	0x9E	48	0xDE	500
0x1F	0.5	0x5F	5	0x9F	50	0xDF	525
0x20	0.52	0x60	5.2	0xA0	52	0xE0	550
0x21	0.54	0x61	5.4	0xA1	54	0xE1	575
0x22	0.56	0x62	5.6	0xA2	56	0xE2	600
0x23	0.58	0x63	5.8	0xA3	58	0xE3	625
0x24	0.6	0x64	6	0xA4	60	0xE4	650
0x25	0.62	0x65	6.2	0xA5	62	0xE5	700

Table 7-4. Motor BEMF Constant Look-Up Table (continued)

MOTOR_BEMF_ CONST (HEX)	Kt _{PH_N} (mV/Hz)	MOTOR_BEMF_ CONST (HEX)	Kt _{PH_N} (mV/Hz)	MOTOR_BEMF_ CONST (HEX)	Kt _{PH_N} (mV/Hz)	MOTOR_BEM F_ CONST (HEX)	Kt _{PH_N} (mV/Hz)
0x26	0.64	0x66	6.4	0xA6	64	0xE6	750
0x27	0.66	0x67	6.6	0xA7	66	0xE7	800
0x28	0.68	0x68	6.8	0xA8	68	0xE8	850
0x29	0.7	0x69	7	0xA9	70	0xE9	900
0x2A	0.72	0x6A	7.2	0xAA	72	0xEA	950
0x2B	0.74	0x6B	7.4	0xAB	74	0xEB	1000
0x2C	0.76	0x6C	7.6	0xAC	76	0xEC	1050
0x2D	0.78	0x6D	7.8	0xAD	78	0xED	1100
0x2E	0.8	0x6E	8	0xAE	80	0xEE	1150
0x2F	0.85	0x6F	8.5	0xAF	85	0xEF	1200
0x30	0.9	0x70	9	0xB0	90	0xF0	1250
0x31	0.95	0x71	9.5	0xB1	95	0xF1	1300
0x32	1	0x72	10	0xB2	100	0xF2	1350
0x33	1.05	0x73	10.5	0xB3	105	0xF3	1400
0x34	1.1	0x74	11	0xB4	110	0xF4	1450
0x35	1.15	0x75	11.5	0xB5	115	0xF5	1500
0x36	1.2	0x76	12	0xB6	120	0xF6	1550
0x37	1.25	0x77	12.5	0xB7	125	0xF7	1600
0x38	1.3	0x78	13	0xB8	130	0xF8	1650
0x39	1.35	0x79	13.5	0xB9	135	0xF9	1700
0x3A	1.4	0x7A	14	0xBA	140	0xFA	1750
0x3B	1.45	0x7B	14.5	0xBB	145	0xFB	1800
0x3C	1.5	0x7C	15	0xBC	150	0xFC	1850
0x3D	1.55	0x7D	15.5	0xBD	155	0xFD	1900
0x3E	1.6	0x7E	16	0xBE	160	0xFE	1950
0x3F	1.65	0x7F	16.5	0xBF	165	0xFF	2000

7.3.15 Motor Parameter Extraction Tool (MPET)

The MCF8329HS uses motor winding resistance, motor winding inductance and Back-EMF constant to estimate motor position in closed loop operation. The MPET routine measures motor back EMF constant and mechanical load inertia and frictional coefficients. Offline measurement of parameters takes place before normal motor operation. TI recommends to estimate the motor parameters before motor start-up to minimize the impact caused due to possible parameter variations.

Figure 7-41 shows the sequence of operation in the MPET routine. The MPET routine is entered when either the MPET_CMD bit is set to 1b or a non-zero target speed is set. The MPET routine consists of three steps namely, Open Loop Acceleration, Current Ramp Down and Coasting. Each one of these steps are executed if the condition shown in Figure 7-41 evaluates to TRUE; if the condition evaluates to FALSE, the algorithm bypasses that particular step and moves on to the next step in the sequence. Once all the steps are completed (or bypassed), the algorithm exits the MPET routine. If target speed is set to a non-zero value, the algorithm begins the start-up and acceleration sequence (to target speed reference) once MPET routine is exited.

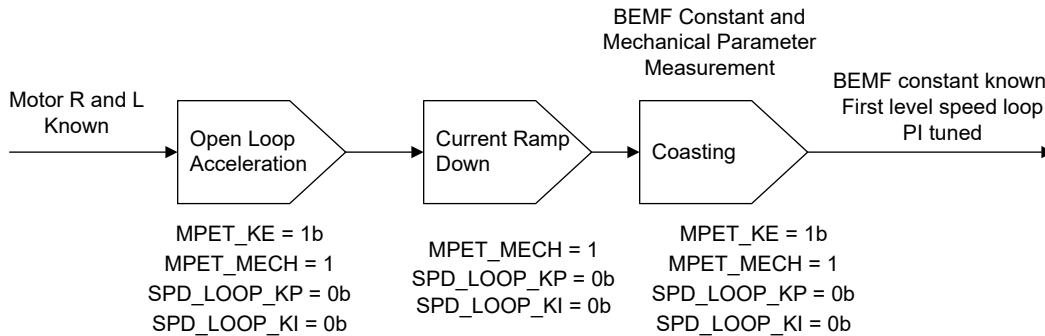

Figure 7-41. MPET Sequence

TI proprietary MPET routine includes following sequence of operation.

- **Open loop Acceleration:** The MPET routine runs align and then open loop acceleration if the back-EMF constant or mechanical parameter measurement are enabled by setting MPET_KE = 1b and MPET_MECH = 1b. The MPET routine incorporates the sequences for mechanical parameter measurement, if the speed loop PI constants are defined as zero, even if MPET_MECH = 0b. This routine uses normal motor operation open loop configuration parameters. The speed slew rate is set by OL_ACC_A1 and OL_ACC_A2, current reference is set by OL_ILIMIT and speed reference is set by OPN_CL_HANDOFF_THR.
- **Current Ramp Down:** After open loop acceleration, if the mechanical parameter measurement is enabled, then the MPET routine optimizes the motor current to lower value sufficient to support the load. If mechanical parameter measurement is disabled (MPET_MECH = 0b, or non-zero speed loop PI parameters) then the MPET will not have the current ramp down sequence.
- **Coasting:** MPET routine completes the sequence by allowing the motor to coast by enabling Hi-Z. The motor back EMF and indicative values of mechanical parameters are measured during the motor coasting period. If the motor back EMF is lower than the threshold defined in STAT_DETECT_THR, the MPET_BEMF_FAULT is generated.

Selecting the parameters from EEPROM or MPET

The MPET estimated values are available in the MTR_PARAMS Register. Setting the MPET_WRITE_SHADOW bit to 1, writes the MPET estimated values to the shadow registers and the user-configured (from EEPROM) values in MOTOR_BEMF_CONST, SPD_LOOP_KP and SPD_LOOP_KI shadow registers will be overwritten by the estimated values from MPET. If any of the shadow registers are initialized to zero (from EEPROM registers), the MPET estimated values are used for those registers independent of the MPET_WRITE_SHADOW setting. The MPET calculates the current loop KP and KI by using the user entered resistance and inductance. The MPET does an estimation of the mechanical parameters including the inertia and frictional coefficient at the shaft (includes both motor and shaft coupled load). These values are used to set an initial values speed loop KP and KI. The estimated speed loop KP and KI setting can be used as an initial setting only and TI recommends to tune these parameters on application by the user based on the performance requirement.

Note

1. FG signal is not accurate during MPET.
2. If CURRENT_LOOP_KP and CURRENT_LOOP_KI are set to zero, then MCF8329HS automatically calculates these coefficients using motor resistance and inductance values.

7.3.16 Single Hall Sensor Operation

MCF8329HS provides the option of redundant motor lock detection using a single digital Hall input - this can be enabled by setting HALL_EN to 1b. MCF8329HS uses the digital Hall input on HALL_IN pin to detect motor lock condition (in open and closed loop states) and to measure the motor speed; when HALL_SNS_STARTUP_EN is set to 1b, the Hall input is also used to adjust the open loop acceleration rate. If no Hall edge transition is observed on HALL_IN pin for 500ms when HALL_EN is set to 1b and input reference is set to a non-zero value, MCF8329HS asserts a motor lock fault and takes protective action as per MTR_LCK_MODE.

Note

- This is an optional feature - when HALL_EN is set 0b, MCF8329HS operates in sensorless mode using only the integrated observer for motor control and lock detection.
- Set HALL_ANGLE_REF = 0h to auto calibrate the Hall sensor offset.

7.3.17 Anti-Voltage Surge (AVS)

When a motor is driven, energy is transferred from the power supply into the motor. Some of this energy is stored in the form of inductive and mechanical energy. If the speed command suddenly drops such that the BEMF voltage generated by the motor is greater than the voltage that is applied to the motor, then the mechanical energy of the motor is returned to the power supply and the V_{PVDD} voltage surges. The AVS feature works to prevent this voltage surge on V_{PVDD} and can be enabled by setting AVS_EN to 1b. AVS can be disabled by setting AVS_EN to 0b.

7.3.18 Active Braking

Decelerating the motor quickly requires the motor mechanical energy to be extracted from the rotor in a fast and controlled manner. However, the DC supply voltage increases if the motor mechanical energy is returned to the power supply during the deceleration process. MCF8329HS is capable of decelerating the motor quickly without pumping energy back into the supply voltage by using a novel technique called active braking. ACTIVE_BRAKE_EN is set to 1b to enable active braking and prevent DC bus voltage spike during fast motor deceleration. Active braking can also be used during reverse drive (see [Section 7.3.10.3](#)) or motor stop (see [Section 7.3.22.3](#)) to reduce the motor speed quickly without DC voltage spike.

The maximum limit on the current sourced from the DC bus (i_{dc_ref}) during active braking can be configured using ACTIVE_BRAKE_CURRENT_LIMIT. The power flow control during active braking is achieved by using both Q-axis (i_q) and D-axis (i_d) components of current. The D-axis current reference (i_{d_ref}) is generated from the error between DC bus current limit (i_{dc_ref}) and the estimated DC bus current (i_{dc}) using a PI controller. The i_{dc} value is estimated from the measured phase currents, phase voltage and DC bus voltage, using power balance equation (equating the instantaneous DC bus power to sum of all three instantaneous phase power assuming 100% efficiency). During active braking, the DC bus current limit (i_{dc_ref}) starts from zero and linearly increases to ACTIVE_BRAKE_CURRENT_LIMIT with current slew rate as defined by ACTIVE_BRAKE_BUS_CURRENT_SLEW_RATE. The gain constants of PI controller can be configured using ACTIVE_BRAKE_KP and ACTIVE_BRAKE_KI. [Figure 7-42](#) shows the active braking i_d current control loop.

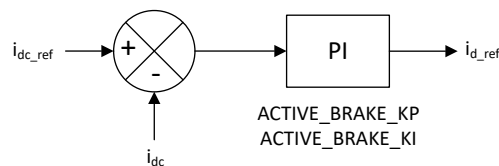

Figure 7-42. Active Braking Current Control Loop for i_{d_ref}

ACTIVE_BRAKE_SPEED_DELTA_LIMIT_ENTRY sets the minimum difference between the initial and target speed above which active braking is entered. For example, consider ACTIVE_BRAKE_SPEED_DELTA_LIMIT_ENTRY is set to 10%; if the initial speed is 100% and target speed is set to 95%, MCF8329HS uses AVS instead of active braking to reach 95% speed since the difference in commanded speed change (5%) is less than ACTIVE_BRAKE_SPEED_DELTA_LIMIT_ENTRY (10%).

Note

1. ACTIVE_BRAKE_SPEED_DELTA_LIMIT_ENTRY is applicable only during deceleration in forward direction and not used during direction change.
2. During active (or closed loop) braking, I_{q_ref} is clamped to -ILIMIT. This (I_{q_ref} being clamped to -ILIMIT) can result in the speed PI loop getting saturated and SPEED_LOOP_SATURATION bit getting set to 1b during deceleration. This bit is automatically set to 0b once the deceleration is completed and the speed PI loop is out of saturation. Hence, speed loop saturation fault is to be ignored during deceleration.
3. Active braking is only available in speed control mode.
4. Active braking is completed when difference between current speed and target speed is <10%.

7.3.19 Output PWM Switching Frequency

MCF8329HS provides the option to configure the output PWM switching frequency of the MOSFETs through PWM_FREQ_OUT. PWM_FREQ_OUT has a range of 10-80 kHz. In order to select optimal output PWM switching frequency, user has to make tradeoff between the current ripple and the switching losses. Generally, motors having lower L/R ratio require higher PWM switching frequency to reduce current ripple.

7.3.20 PWM Dithering

MCF8329HS provides the option of PWM dithering to reduce the EMI generated by MOSFET switching - when enabled, the PWM switching frequency is varied continuously (within a user configured frequency range) around the PWM_FREQ_OUT setting to spread the EMI energy across the frequency spectrum and reduce the EMI peak values. The user configured frequency range for PWM dithering is set by PWM_DITHER_DEPTH; setting PWM_DITHER_DEPTH to 0x0 disables PWM dithering. PWM_DITHER_DEPTH provides $\pm 5\%$, $\pm 7.5\%$ and $\pm 10\%$ frequency spread options. When PWM_FREQ_OUT is set to 25kHz and PWM_DITHER_DEPTH is set to $\pm 10\%$, the PWM switching frequency applied to the MOSFETs continuously varies between 22.5kHz (25kHz-10%) and 27.5kHz (25kHz+10%), thereby reducing the EMI peaks at multiples of 25kHz. PWM dithering is available in two modes - random or triangular (configured by PWM_DITHER_MODE). In random dithering, the PWM switching frequency is continuously varied randomly within the range set by PWM_FREQ_OUT and PWM_DITHER_DEPTH. In triangular dithering, the PWM switching frequency is varied at user configured slew rate (configured by PWM_DITHER_STEP) as shown in [Figure 7-43](#)

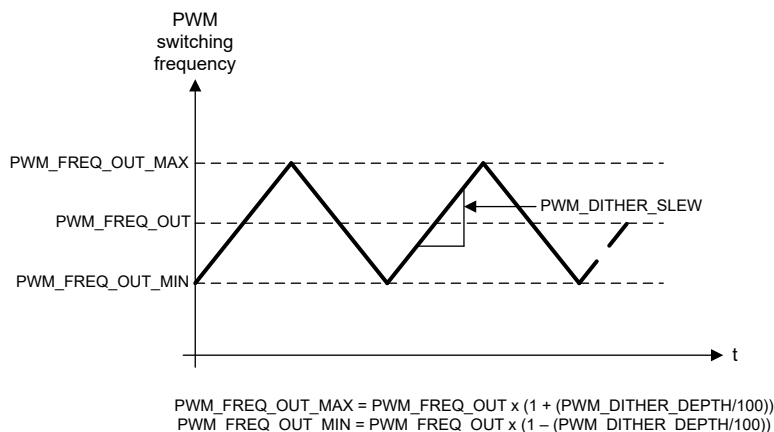

Figure 7-43. Triangular PWM Dithering

The PWM switching frequency slew rate (PWM_DITHER_SLEW in [Figure 7-43](#)) is set as shown in [Equation 13](#).

$$PWM_DITHER_SLEW \text{ (kHz/s)} = PWM_DITHER_STEP * SLEW_SCALING \text{ FACTOR} \quad (13)$$

SLEW_SCALING FACTOR varies with PWM switching frequency as listed in [Table 7-5](#).

Table 7-5. SLEW_SCALING FACTOR vs CLOCK_FREQUENCY vs PWM switching frequency

PWM switching frequency (kHz)	SLEW_SCALING FACTOR		
	CLOCK_FREQUENCY = HIGH	CLOCK_FREQUENCY = MEDIUM	CLOCK_FREQUENCY = LOW
10	1	1	1
15	2.3	2.3	1.1
20	4	2	2
25	3.1	3.1	2.1
30	4.5	4.5	3
35	6.1	4.1	3.1
40	8	5.3	3.2
45	6.8	6.8	4.1
50	8.4	6.3	4.2
55	10.1	7.6	Not Applicable
60	12.0	7.2	Not Applicable
65	10.6	8.5	Not Applicable
70	12.3	9.8	Not Applicable
75	14.1	9.4	Not Applicable
80	12.8	10.6	Not Applicable

7.3.21 Voltage Sense Scaling

The MCF8329HS integrates dynamic voltage scaling to improve the resolution of phase voltage and DC bus voltage sensing. The DC bus voltage is sensed at the PVDD pin. The motor phase voltages and DC bus voltage are sensed using an integrated voltage divider with a configurable scaling of 5V/V or 10V/V or 20V/V to limit the sense voltage to less than 3V across operating voltage. Setting the bit DYNAMIC_VOLTAGE_GAIN_EN = 0b disables dynamic voltage scaling and MCF8329HS uses BUS_VOLT setting to configure the voltage scaling. Setting the bit DYNAMIC_VOLTAGE_GAIN_EN = 1b enables dynamic voltage scaling and MCF8329HS senses the DC bus voltage during motor start-up and selects the appropriate voltage scaling of 5V/V or 10V/V or 20V/V.

7.3.22 Motor Stop Options

The MCF8329HS provides different options for stopping the motor which can be configured by MTR_STOP.

7.3.22.1 Coast (Hi-Z) Mode

Coast (Hi-Z) mode is configured by setting MTR_STOP to 00b. When motor stop command is received, the MCF8329HS turns off all the external MOSFETs creating Hi-Z state at the phase motor terminals. When the MCF8329HS transitions from driving the motor into a Hi-Z state, the inductive current in the motor windings continues to flow and the energy returns to the power supply through the body diodes in the MOSFET output stage (see example Figure 7-44).

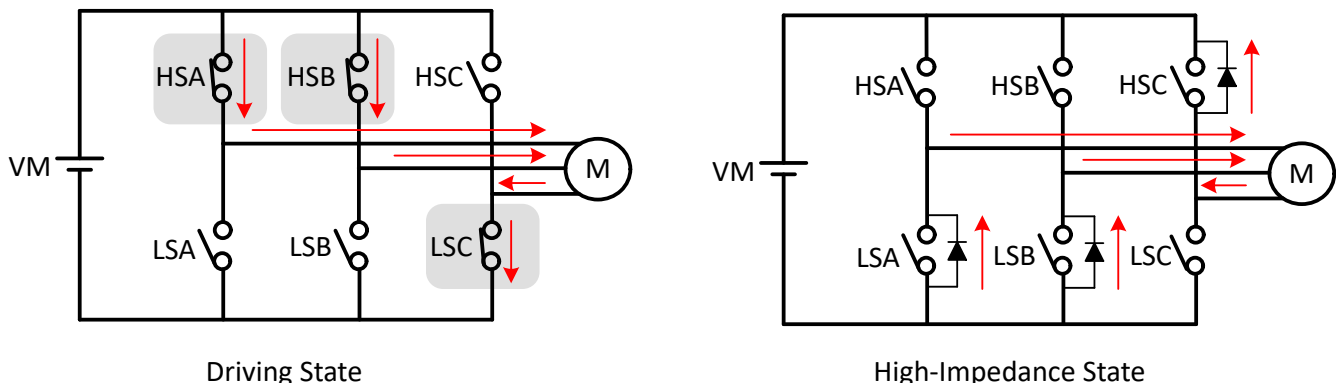

Figure 7-44. Coast (Hi-Z) Mode

In this example, current is applied to the motor through the high-side phase-A MOSFET (HSA), high-side phase-B MOSFET (HSB) and returned through the low-side phase-C MOSFET (LSC). When motor stop command is received all 6 MOSFETs transition to Hi-Z state and the inductive energy returns to supply through body diodes of MOSFETs LSA, LSB and HSC.

7.3.22.2 Low-Side Braking

Low-side braking mode is configured by setting MTR_STOP to 01b. When a motor stop command is received, the output speed is reduced to a value defined by BRAKE_SPEED_THRESHOLD prior to turning all low-side MOSFETs ON (see example Figure 7-45) for a time configured by MTR_STOP_BRK_TIME. If the motor speed is below BRAKE_SPEED_THRESHOLD prior to receiving stop command, then the MCF8329HS transitions directly into the brake state. After applying the brake for MTR_STOP_BRK_TIME, the MCF8329HS transitions into the Hi-Z state by turning OFF all MOSFETs.

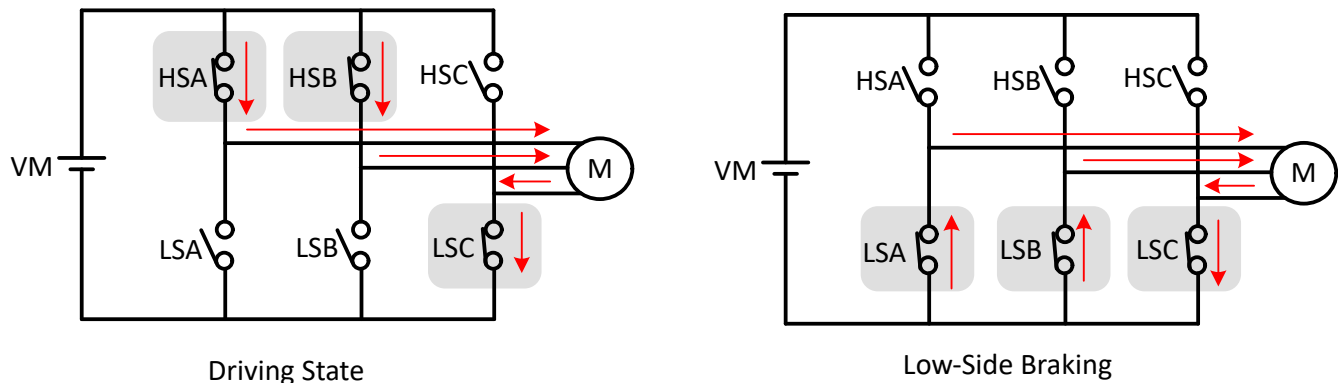

Figure 7-45. Low-Side Braking

The MCF8329HS can also enter low-side braking through BRAKE pin input. When BRAKE pin is pulled to HIGH state, the output speed is reduced to a value defined by BRAKE_SPEED_THRESHOLD prior to turning all low-side MOSFETs ON. In this case, MCF8329HS stays in low-side brake state till BRAKE pin changes to LOW state. When BRAKE pin is pulled to HIGH state without a run command (REF is set to 0), then MCF8329HS turns ON all low-side MOSFETs immediately.

7.3.22.3 Active Spin-Down

Active spin down mode is configured by setting MTR_STOP to 10b. When a motor stop command is received, the MCF8329HS reduces SPEED_REF to ACT_SPIN_THR and then transitions to Hi-Z state by turning all MOSFETs OFF. The advantage of this mode is that by reducing SPEED_REF, the motor is decelerated to lower speed thereby reducing the phase currents before entering Hi-Z. Now, when the motor transitions into Hi-Z state, the energy transfer to the power supply is reduced. The threshold ACT_SPIN_THR needs to be configured high enough for MCF8329HS to not lose synchronization with the motor.

7.3.23 FG Configuration

The MCF8329HS provides information about the motor speed through the Frequency Generate (FG) pin. In MCF8329HS, the FG pin output is configured through FG_CONFIG. When FG_CONFIG is configured to 0b, the FG output is active as long as the MCF8329HS is driving the motor. When FG_CONFIG is configured to 1b, the MCF8329HS provides an FG output as long as the MCF8329HS is driving the motor and also during coasting until the motor back-EMF falls below the threshold configured by FG_BEMF_THR.

7.3.23.1 FG Output Frequency

The FG output frequency can be configured by FG_DIV. Many applications require the FG output to provide a pulse for every mechanical rotation of the motor. Different FG_DIV configurations can accomplish this for 2-pole up to 30-pole motors.

Figure 7-46 shows the FG output when MCF8329HS has been configured to provide FG pulses thrice every electrical cycle, once every electrical cycle (2 poles), once every two electrical cycle (4 poles), once every three electrical cycles (6 poles), once every four electrical cycles (8 poles), and so on.

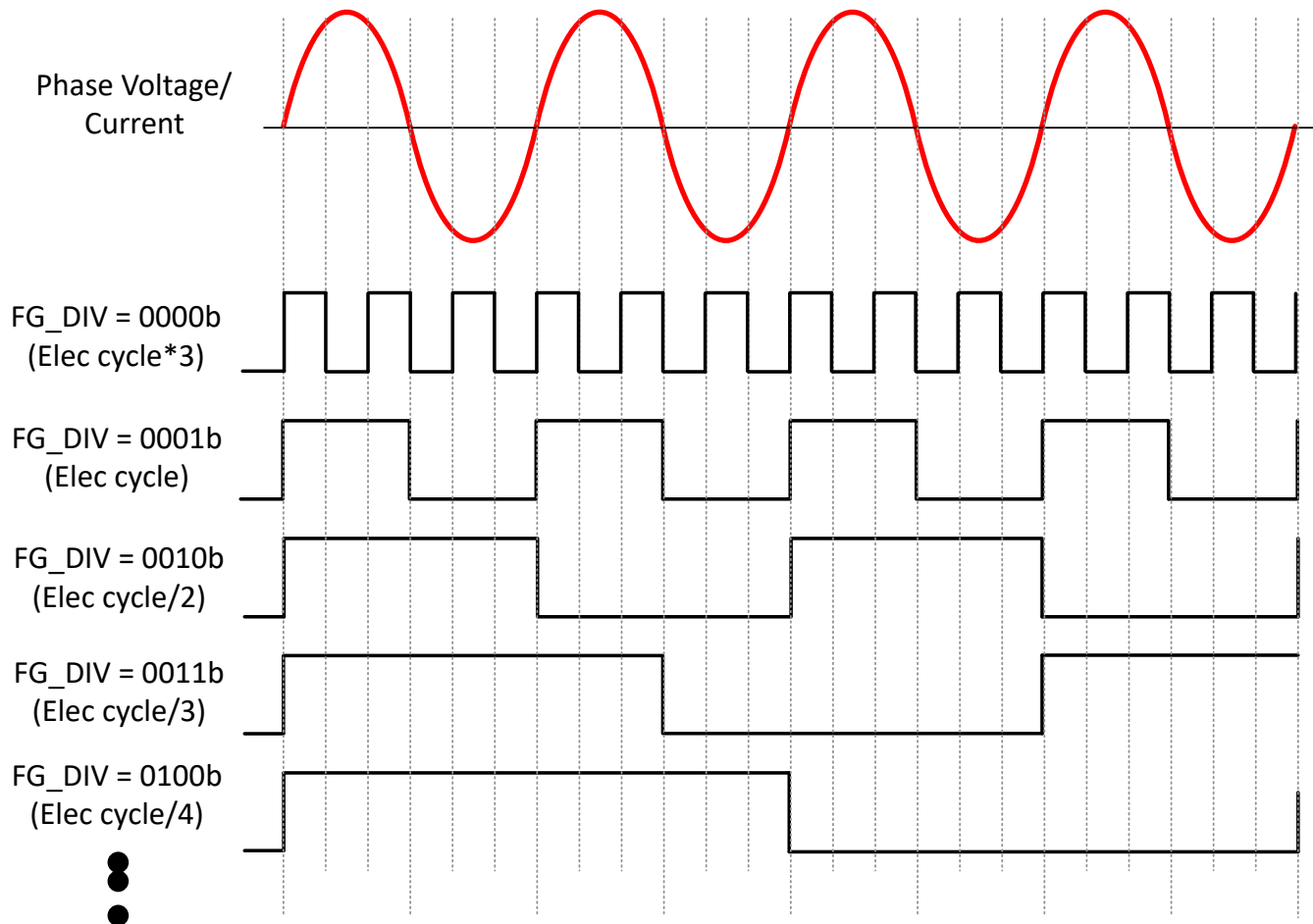

Figure 7-46. FG Frequency Divider

7.3.23.2 FG in Open-Loop

During closed loop (commutation) operation, the driving speed (FG output frequency) and the actual motor speed are synchronized. During open-loop operation, however, FG cannot reflect the actual motor speed. The open loop and closed loop here refers to the motor commutation method and not referred to closed loop speed or power control.

The MCF8329HS provides three options for controlling the FG output during open loop, as shown in Figure 7-47. The selection of these options is configured through FG_SEL.

If FG_SEL is set to,

- 00b : Output FG in ISD, open loop and closed loop.
- 01b : Output FG in only closed loop. FG pin is Hi-Z (high with external pull up) during open loop.
- 10b: The FG output reflects the driving frequency during open loop operation in the first motor start-up cycle after power-on, sleep/standby; FG is Hi-Z (high with external pull up) during open loop operation in subsequent start-up cycles.

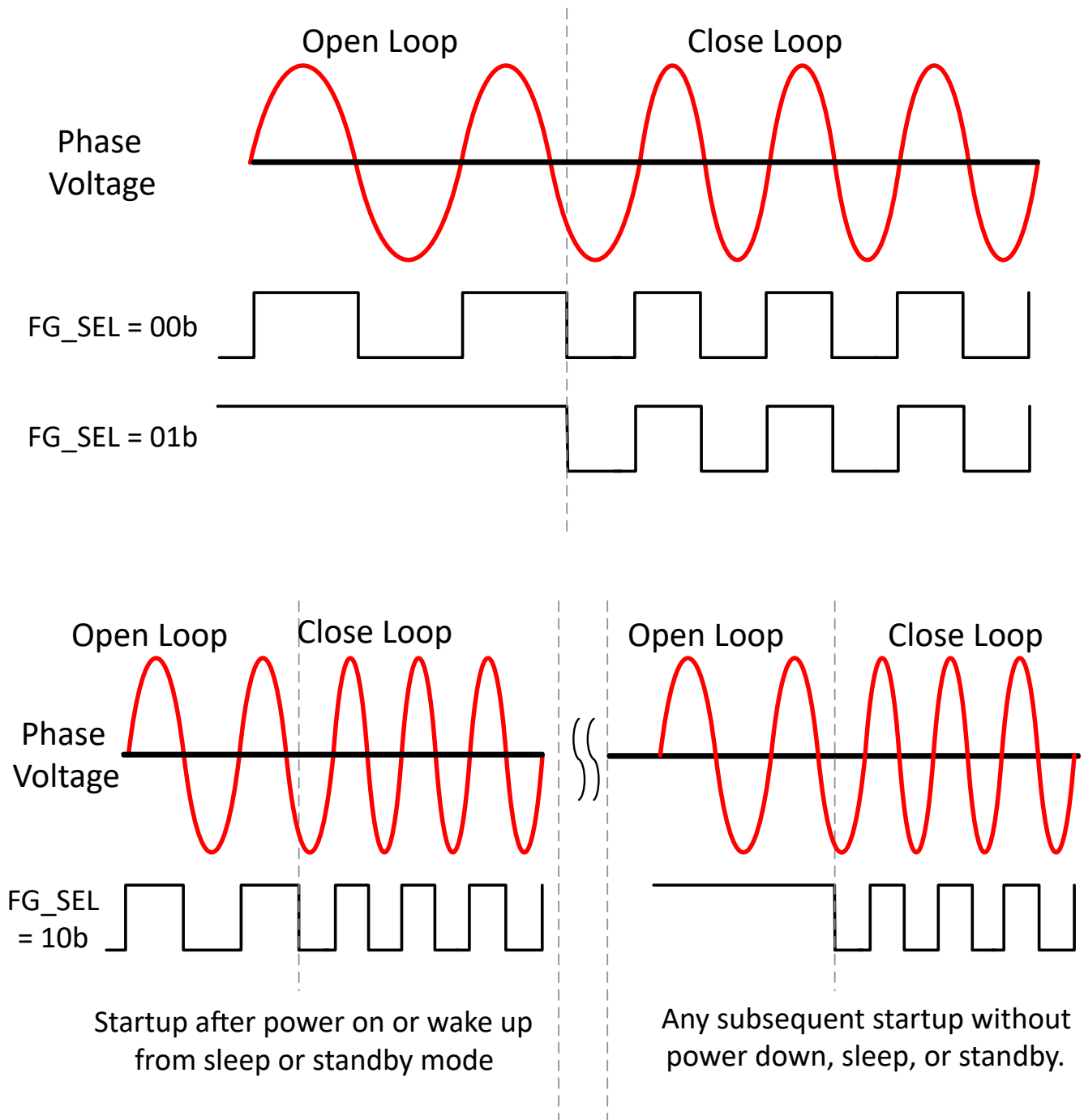

Figure 7-47. FG Behavior During Open Loop

7.3.23.3 FG During Motor Stop

The FG pin state when the motor stops rotating can be defined using FG_IDLE_CONFIG. The motor stop is decided by FG_BEMF_THR.

7.3.23.4 FG Behavior During Fault

The FG behavior during faults (those reported on nFAULT pin) can be configured using FG_FAULT_CONFIG.

In addition to reporting fault status on FG, MCF8329HS also provides the option of reporting the fault type on FG pin by encoding the fault type information as a unique duty cycle at 1Hz frequency as shown in [Figure 7-48](#).

Eight types of faults can be reported on FG pin - loss of phase (no motor), motor lock, over current (VDS, VSNS, lock current limits), PVDD over voltage, PVDD under voltage, over temperature, external MCU (watchdog and I²C CRC) and dry run.

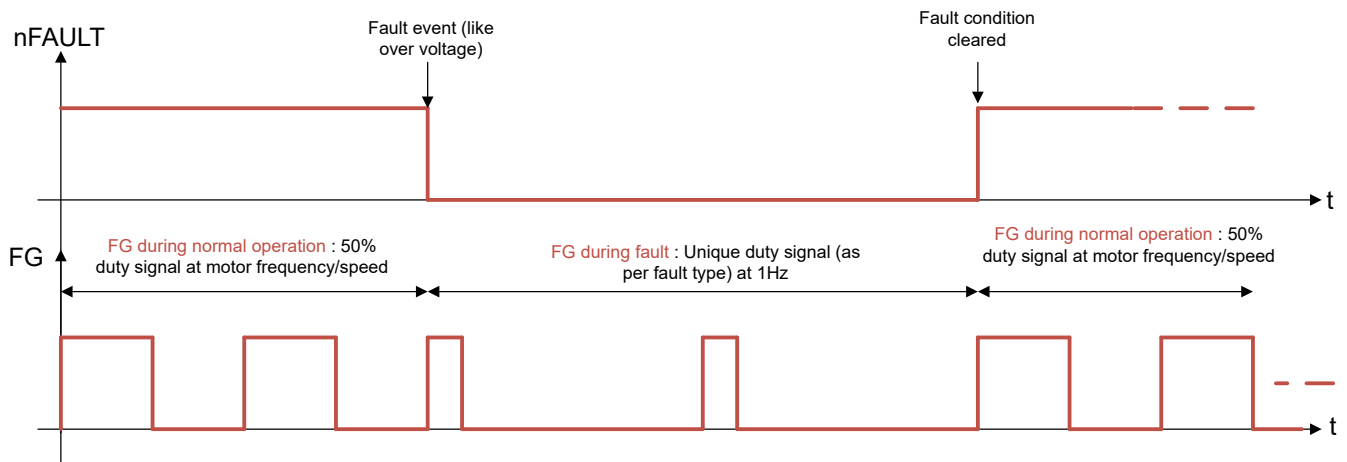

Figure 7-48. Fault Indication over FG

The duty cycle and priority (1 being the highest) associated with each fault type indicated on FG pin is as shown in [Table 7-6](#),

Table 7-6. Duty cycle and Priority for Fault Indication on FG pin

Fault Type	Duty Cycle	Priority
Loss of phase	10	1
Over current	20	2
Motor lock	30	3
Dry run	90	4
External MCU	80	5
Over temperature	70	6
PVDD under voltage	40	7
PVDD over voltage	60	8

If FG_FAULT_CONFIG is set to,

- 00b: FG pin pulled low on fault.
- 01b: FG pin in Hi-Z (high with external pull up) on reported faults.
- 10b: FG reports fault type as a unique duty cycle at 1Hz
- 11b: FG active till BEMF drops below BEMF threshold defined by FG_BEMF_THR if FG_CONFIG is set to 1b

Note

Fault type reporting on FG pin is not be available in case of retry faults with retry time < 1s (FG signal time period for fault type reporting) or when a particular type of fault is configured in 'report only' mode.

7.3.24 Protections

The MCF8329HS is protected from a host of fault events including motor lock, PVDD undervoltage, AVDD undervoltage, GVDD undervoltage, bootstrap undervoltage, overtemperature and overcurrent events. [Table 7-7](#) summarizes the response, recovery modes, gate driver status, reporting mechanism for different faults.

Note

1. Actionable and report only faults (latched or retry) are always reported on nFAULT pin (as logic low).
2. Priority order for multi-fault scenarios is latched > slower retry time fault > faster retry time fault > report only fault. For example, if a latched and retry fault happen simultaneously, the device stays latched in fault mode until user issues clear fault command by writing 1b to CLR_FLT or through a power recycle. If two retry faults with different retry times happen simultaneously, the device retries only after the longer (slower) retry time lapses.
3. Recovery refers only to state of gate driver after the fault condition is removed. Automatic indicates that the device automatically recovers (and gate driver outputs and hence external FETs are active) when retry time lapses after the fault condition is removed. Latched indicates that the device waits for clearing of fault condition (by writing 1b to CLR_FLT bit) or through a power recycle.
4. The GVDD undervoltage, BST under voltage, VDS OCP, SENSE OCP faults can take up to 200ms after fault response (gate driver outputs pulled low to put the external FETs in Hi-Z) to be reported on nFAULT pin (as logic low).
5. Latched faults can take up to 200ms after CLR_FLT command is issued (over I²C) to be cleared.
6. CLR_FLT command (over I²C) will clear all the faults (and corresponding fault status bits) including latched, automatic recovery (retry) and report only faults.
7. When device resumes normal operation after retry time (of an automatic recovery fault) lapses, fault status bits of all automatic recovery (retry) and report only faults set to 1b are cleared (reset to 0b) automatically.

Table 7-7. Fault Action and Response

FAULT	CONDITION	CONFIGURATION	REPORT	GATE DRIVER	LOGIC	RECOVERY
PVDD under-voltage (PVDD_UV)	$V_{PVDD} < V_{PVDD_UV}$	—	nFAULT	Disabled	Disabled	Automatic: $V_{PVDD} > V_{PVDD_UV}$
AVDD POR (AVDD_POR)	$V_{AVDD} < V_{AVDD_POR}$	—	nFAULT	Disabled	Disabled	Automatic: $V_{AVDD} > V_{AVDD_POR}$
GVDD under-voltage (GVDD_UV)	$V_{GVDD} < V_{GVDD_UV}$	GVDD_UV_MODE = 0b	nFAULT and GATE_DRIVER_FAULT_STATUS Register	Pulled Low ⁽¹⁾	Active	Latched: CLR_FLT
		GVDD_UV_MODE = 1b	nFAULT and GATE_DRIVER_FAULT_STATUS Register	Pulled Low ⁽¹⁾	Active	Retry: t_{LCK_RETRY}
BSTx under-voltage (BST_UV)	$V_{BSTx} - V_{SHx} < V_{BST_UV}$	DIS_BST_FLT = 0b BST_UV_MODE = 0b	nFAULT and GATE_DRIVER_FAULT_STATUS Register	Pulled Low ⁽¹⁾	Active	Latched: CLR_FLT
		DIS_BST_FLT = 0b BST_UV_MODE = 1b	nFAULT and GATE_DRIVER_FAULT_STATUS Register	Pulled Low ⁽¹⁾	Active	Retry: t_{LCK_RETRY}
V _{DS} overcurrent (VDS_OCP)	$V_{DS} > V_{SEL_VDS_LVL}$	DIS_VDS_FLT = 0b VDS_FLT_MODE = 0b	nFAULT and GATE_DRIVER_FAULT_STATUS Register	Pulled Low ⁽¹⁾	Active	Latched: CLR_FLT
		DIS_VDS_FLT = 0b VDS_FLT_MODE = 1b	nFAULT and GATE_DRIVER_FAULT_STATUS Register	Pulled Low ⁽¹⁾	Active	Retry: t_{LCK_RETRY}

Table 7-7. Fault Action and Response (continued)

FAULT	CONDITION	CONFIGURATION	REPORT	GATE DRIVER	LOGIC	RECOVERY
V _{SENSE} overcurrent (SEN_OCP) V _{SENSE} overcurrent (SEN_OCP)	V _{SP} > V _{SENSE_LVL}	DIS_SNS_FLT = 0b SNS_FLT_MODE = 0b	nFAULT and GATE_DRIVER_FAULT_STATUS Register	Pulled Low ⁽¹⁾	Active	Latched: CLR_FLT
		DIS_SNS_FLT = 0b SNS_FLT_MODE = 1b	nFAULT and GATE_DRIVER_FAULT_STATUS Register	Pulled Low ⁽¹⁾	Active	Retry: t _{LCK_RETRY}
3 Motor Lock (MTR_LCK)	Motor lock: Abnormal Speed; No Motor Lock; Abnormal BEMF	MTR_LCK_MODE = 000b	nFAULT and CONTROLLER_FAULT_STATUS register	Pulled Low ⁽¹⁾ (MOSFETs in Hi-Z)	Active	Latched: CLR_FLT
		MTR_LCK_MODE = 001b or 010b	nFAULT and CONTROLLER_FAULT_STATUS register	Low side brake	Active	Latched: CLR_FLT
		MTR_LCK_MODE = 011b	nFAULT and CONTROLLER_FAULT_STATUS register	Pulled Low ⁽¹⁾ (MOSFETs in Hi-Z)	Active	Retry: t _{LCK_RETRY}
		MTR_LCK_MODE = 100b or 101b	nFAULT and CONTROLLER_FAULT_STATUS register	Low side brake	Active	Retry: t _{LCK_RETRY}
		MTR_LCK_MODE = 110b	nFAULT and CONTROLLER_FAULT_STATUS register	Active	Active	No action
		MTR_LCK_MODE = 111b	None	Active	Active	No action
Hardware Lock-Detection Current Limit (HW_LOCK_ILIMIT)	Phase Current > HW_LOCK_ILIMIT	HW_LOCK_ILIMIT_MODE = 000b	nFAULT and CONTROLLER_FAULT_STATUS register	Pulled Low ⁽¹⁾ (MOSFETs in Hi-Z)	Active	Latched: CLR_FLT
		HW_LOCK_ILIMIT_MODE = 001b or 010b	nFAULT and CONTROLLER_FAULT_STATUS register	Low-side brake	Active	Latched: CLR_FLT
		HW_LOCK_ILIMIT_MODE = 011b	nFAULT and CONTROLLER_FAULT_STATUS register	Pulled Low ⁽¹⁾ (MOSFETs in Hi-Z)	Active	Retry: t _{LCK_RETRY}
		HW_LOCK_ILIMIT_MODE = 100b or 101b	nFAULT and CONTROLLER_FAULT_STATUS register	Low-side brake	Active	Retry: t _{LCK_RETRY}
		HW_LOCK_ILIMIT_MODE = 110b	nFAULT and CONTROLLER_FAULT_STATUS register	Active	Active	No action
		HW_LOCK_ILIMIT_MODE = 111b	None	Active	Active	No action

Table 7-7. Fault Action and Response (continued)

FAULT	CONDITION	CONFIGURATION	REPORT	GATE DRIVER	LOGIC	RECOVERY
ADC based Lock-Detection Current Limit (LOCK_ILIMIT)	Phase Current > LOCK_ILIMIT	LOCK_ILIMIT_MODE = 000b	nFAULT and CONTROLLER_FAULT_STATUS register	Pulled Low ⁽¹⁾ (MOSFETs in Hi-Z)	Active	Latched: CLR_FLT
		LOCK_ILIMIT_MODE = 001b or 010b	nFAULT and CONTROLLER_FAULT_STATUS register	Low-side brake	Active	Latched: CLR_FLT
		LOCK_ILIMIT_MODE = 011b	nFAULT and CONTROLLER_FAULT_STATUS register	Pulled Low ⁽¹⁾ (MOSFETs in Hi-Z)	Active	Retry: t_{LCK_RETRY}
		LOCK_ILIMIT_MODE = 100b or 101b	nFAULT and CONTROLLER_FAULT_STATUS register	Low-side brake	Active	Retry: t_{LCK_RETRY}
		LOCK_ILIMIT_MODE = 110b	nFAULT and CONTROLLER_FAULT_STATUS register	Active	Active	No action
		LOCK_ILIMIT_MODE = 111b	None	Active	Active	No action
MPET Back-EMF Fault (MPET_BEMF_FAULT)	Motor Back EMF < STAT_DETECT_THR	MPET_CMD = 1 or MPET_KE = 1	nFAULT and CONTROLLER_FAULT_STATUS register	Hi-Z	Active	Latched: CLR_FLT
Maximum V_{PVDD} (over-voltage) fault	$V_{PVDD} >$ MAX_VM_MOTOR, if MAX_VM_MOTOR \neq 000b	MAX_VM_MODE = 0b	nFAULT and CONTROLLER_FAULT_STATUS register	Pulled Low ⁽¹⁾ (MOSFETs in Hi-Z)	Active	Latched: CLR_FLT
		MAX_VM_MODE = 1b	nFAULT and CONTROLLER_FAULT_STATUS register	Pulled Low ⁽¹⁾ (MOSFETs in Hi-Z)	Active	Automatic: ($V_{PVDD} <$ MAX_VM_MOTOR - VOLTAGE_HYSTERE SIS) V
Minimum V_{PVDD} (under-voltage) fault	$V_{PVDD} <$ MIN_VM_MOTOR, if MIN_VM_MOTOR \neq 000b	MIN_VM_MODE = 0b	nFAULT and CONTROLLER_FAULT_STATUS register	Pulled Low ⁽¹⁾ (MOSFETs in Hi-Z)	Active	Latched: CLR_FLT
		MIN_VM_MODE = 1b	nFAULT and CONTROLLER_FAULT_STATUS register	Pulled Low ⁽¹⁾ (MOSFETs in Hi-Z)	Active	Automatic: ($V_{PVDD} >$ MIN_VM_MOTOR + VOLTAGE_HYSTERE SIS) V
Current Loop Saturation	Indication of current loop saturation due to lower V_{VM}	SATURATION_FLAG S_EN = 1b	nFAULT and CONTROLLER_FAULT_STATUS register	Active; motor speed/power/current may not reach reference	Active	Automatic: motor will reach reference operating point upon exiting saturation
Speed/power Loop Saturation	Indication of speed/power loop saturation due to lower V_{VM} , lower ILIMIT setting etc.,	SATURATION_FLAG S_EN = 1b	nFAULT and CONTROLLER_FAULT_STATUS register	Active; motor speed/power may not reach reference	Active	Automatic: motor will reach reference operating point upon exiting saturation

Table 7-7. Fault Action and Response (continued)

FAULT	CONDITION	CONFIGURATION	REPORT	GATE DRIVER	LOGIC	RECOVERY
External Watchdog Fault	Time between watchdog tickles > EXT_WD_CONFIG	EXT_WD_EN = 1b EXT_WD_FAULT_MODE = 0b and LIMP_HOME_EN = 0b	nFAULT and CONTROLLER_FAULT_STATUS register	Active	Active	No action
		EXT_WD_EN = 1b EXT_WD_FAULT_MODE = 0b and LIMP_HOME_EN = 1b	nFAULT and CONTROLLER_FAULT_STATUS register	Active (reference latched at current value till CLR_FLT)	Active	Latched: CLR_FLT
		EXT_WD_EN = 1b EXT_WD_FAULT_MODE = 1b and LIMP_HOME_EN = 0b	nFAULT and CONTROLLER_FAULT_STATUS register	Pulled Low (MOSFETs in Hi-Z)	Active	Latched: CLR_FLT
		EXT_WD_EN = 1b EXT_WD_FAULT_MODE = 1b and LIMP_HOME_EN = 1b	nFAULT and CONTROLLER_FAULT_STATUS register	Active (reference latched at REF_OFF 1)	Active	Latched: CLR_FLT
EEPROM Fault	Indicates EEPROM contents error/mismatch; content evaluation happens whenever a EEPROM read is issued	EEP_FAULT_MODE = 0b	nFAULT and CONTROLLER_FAULT_STATUS register	Pulled Low (MOSFETs in Hi-Z)	Active	Latched: CLR_FLT
		EEP_FAULT_MODE = 1b	nFAULT and CONTROLLER_FAULT_STATUS register	Active	Active	No action
I ² C CRC Fault	Indicates error in I ² C transaction as a CRC mismatch	I2C_CRC_ERR_MODE = 0b	nFAULT and CONTROLLER_FAULT_STATUS register	Pulled Low (MOSFETs in Hi-Z)	Active	Latched: CLR_FLT
		I2C_CRC_ERR_MODE = 1b	nFAULT and CONTROLLER_FAULT_STATUS register	Active	Active	No action
Dry Run Detection	Refer Section 7.3.24.17	DRY_RUN_MODE = 00b	None	Active	Active	No action
		DRY_RUN_MODE = 01b	nFAULT and CONTROLLER_FAULT_STATUS register	Active	Active	No action
		DRY_RUN_MODE = 10b	nFAULT and CONTROLLER_FAULT_STATUS register	Pulled Low (MOSFETs in Hi-Z)	Active	Retry: t _{LCK_RETRY}
		DRY_RUN_MODE = 11b	nFAULT and CONTROLLER_FAULT_STATUS register	Pulled Low (MOSFETs in Hi-Z)	Active	Latched: CLR_FLT

Table 7-7. Fault Action and Response (continued)

FAULT	CONDITION	CONFIGURATION	REPORT	GATE DRIVER	LOGIC	RECOVERY
Thermal shutdown (TSD)	$T_J > T_{TSD}$	OTS_AUTO_RECOVERY = 0b	nFAULT and GATE_DRIVER_FAULT_STATUS Register	Pulled Low (MOSFETs in Hi-Z) ⁽¹⁾	Active	Latched: CLR_FLT
		OTS_AUTO_RECOVERY = 1b	nFAULT and GATE_DRIVER_FAULT_STATUS Register	Pulled Low (MOSFETs in Hi-Z) ⁽¹⁾	Active	Automatic: $T_J < T_{OTSD} - T_{HYS}$

(1) Pulled Low: GHx and GLx are actively pulled low by the gate driver

Note

Any fault reporting on nFAULT pin or CONTROLLER_FAULT_STATUS register or GATE_DRIVER_FAULT_STATUS register can have a latency up to 200ms.

7.3.24.1 PVDD Supply Undervoltage Lockout (PVDD_UV)

If at any time the power supply voltage on the PVDD pin falls below the V_{PVDD_UV} threshold for longer than the $t_{PVDD_UV_DG}$ time, the device detects a PVDD undervoltage event. After detecting the undervoltage condition, the gate driver is disabled, the charge pump is disabled, the internal digital logic is disabled, and the nFAULT pin is driven low. Normal operation starts again (the gate driver becomes operable and the nFAULT pin is released) when the PVDD pin rises above V_{PVDD_UV} .

7.3.24.2 AVDD Power on Reset (AVDD_POR)

If at any time the supply voltage on the AVDD pin falls below the V_{AVDD_POR} threshold for longer than the $t_{AVDD_POR_DG}$ time, the device enters an inactive state, disabling the gate driver, the charge pump, and the internal digital logic, and nFAULT is driven low. Normal operation (digital logic operational) requires AVDD to exceed V_{AVDD_POR} level.

7.3.24.3 GVDD Undervoltage Lockout (GVDD_UV)

If at any time the voltage on the GVDD pin falls lower than the V_{GVDD_UV} threshold voltage for longer than the $t_{GVDD_UV_DG}$ time, the device detects a GVDD undervoltage event. After detecting the GVDD_UV undervoltage event, all of the gate driver outputs are driven low to disable the external MOSFETs, the charge pump is still running and nFAULT pin is driven low.

The device can be configured in a latched fault state or retry mode upon a GVDD_UV condition using the GVDD_UV_MODE bit. With GVDD_UV_MODE = 0b, normal operation resumes after the GVDD_UV condition is cleared and a clear fault command is issued through the CLR_FLT bit. With GVDD_UV_MODE = 1b, normal operation resumes after the GVDD_UV condition is cleared and a time period of t_{LCK_RETRY} is elapsed.

7.3.24.4 BST Undervoltage Lockout (BST_UV)

If at any time the voltage across BSTx and SHx pins falls lower than the V_{BST_UV} threshold voltage for longer than the $t_{BST_UV_DG}$ time, the device detects a BST undervoltage event. After detecting the BST_UV event, all of the gate driver outputs are driven low to disable the external MOSFETs, and nFAULT pin is driven low. BST_UV can be disabled by configuring DIS_BST_FLT to 1b.

The device can be configured in a latched fault state or retry mode upon a BST_UV condition using the BST_UV_MODE bit. With BST_UV_MODE = 0b, normal operation resumes after the BST_UV condition is cleared and a clear fault command is issued through the CLR_FLT bit. With BST_UV_MODE = 1b, normal operation resumes after the BST_UV condition is cleared and a time period of t_{LCK_RETRY} is elapsed.

7.3.24.5 MOSFET VDS Overcurrent Protection (VDS_OCP)

The device has adjustable VDS voltage monitors to detect overcurrent or short-circuit conditions on the external power MOSFETs. A MOSFET overcurrent event is sensed by monitoring the VDS voltage drop across the external MOSFET $R_{DS(on)}$. The high-side VDS monitors measure between the PVDD and SHx pins and the low-side VDS monitors measure between the SHx and LSS pins. If the voltage across external MOSFET exceeds the threshold set by SEL_VDS_LVL for longer than the t_{DS_DG} deglitch time, a V_{DS_OCP} event is recognized. After detecting the VDS overcurrent event, all of the gate driver outputs are driven low to disable the external MOSFETs and nFAULT pin is driven low. V_{DS_OCP} can be disabled by configuring DIS_VDS_FLT to 1b.

The device can be configured in a latched fault state or retry mode upon a V_{DS_OCP} event using the VDS_FLT_MODE bit. With VDS_FLT_MODE = 0b, normal operation resumes after the V_{DS_OCP} condition is cleared and a clear fault command is issued through the CLR_FLT bit. With VDS_FLT_MODE = 1b, normal operation resumes after the V_{DS_OCP} condition is cleared and a time period of t_{LCK_RETRY} is elapsed. FET-wise VDS fault information is available in GATE_DRIVER_FAULT_STATUS register.

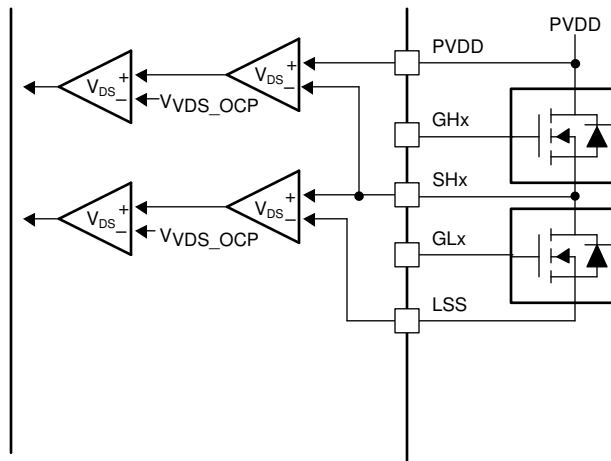

Figure 7-49. VDS Monitors

7.3.24.6 VSENSE Overcurrent Protection (SEN_OCP)

Overcurrent is also monitored by sensing the voltage drop across the external current sense resistor between LSS and GND pin. If at any time the voltage on the LSS input exceeds the VSEN_OCP threshold for longer than the t_{DS_DG} deglitch time, a SEN_OCP event is recognized. After detecting the SEN_OCP overcurrent event, all of the gate driver outputs are driven low to disable the external MOSFETs and nFAULT pin is driven low. The V_{SENSE} threshold is fixed at 0.5V. V_{SEN_OCP} can be disabled by configuring DIS_SNS_FLT to 1b.

The device can be configured in a latched fault state or retry mode upon a V_{DS_OCP} event using the SNS_FLT_MODE bit. With SNS_FLT_MODE = 0b, normal operation resumes after the V_{SEN_OCP} condition is cleared and a clear fault command is issued through the CLR_FLT bit. With SNS_FLT_MODE = 1b, normal operation resumes after the V_{SEN_OCP} condition is cleared and a time period of t_{LCK_RETRY} is elapsed.

7.3.24.7 Thermal Shutdown (OTSD)

If the die temperature exceeds the trip point of the thermal shutdown limit (T_{OTSD}), an OTSD event is recognized. After detecting the OTSD overtemperature event, all of the gate driver outputs are driven low to disable the external MOSFETs, and nFAULT pin is driven low. The over temperature protection can be configured for a latched mode or automatic recovery mode by configuring OTS_AUTO_RECOVERY. In latched mode, normal operation resumes after the T_{OTSD} condition is cleared and a clear fault command is issued through the CLR_FLT bit. In automatic recovery mode, normal operation resumes after the T_{OTSD} condition is cleared.

7.3.24.8 Hardware Lock Detection Current Limit (HW_LOCK_ILIMIT)

The hardware lock detection current limit function provides a configurable threshold for limiting the current to prevent damage to the system. The output of current sense amplifier is connected to hardware

comparator. If at any time, the voltage on the output of CSA exceeds HW_LOCK_ILIMIT threshold for a time longer than $t_{HW_LOCK_ILIMIT}$, a HW_LOCK_ILIMIT event is recognized and action is taken according to the HW_LOCK_ILIMIT_MODE. The threshold is set through HW_LOCK_ILIMIT, the $t_{HW_LCK_ILIMIT}$ is set through the HW_LOCK_ILIMIT_DEG. HW_LOCK_ILIMIT_MODE bit can operate in four different modes: HW_LOCK_ILIMIT latched shutdown, HW_LOCK_ILIMIT automatic retry, HW_LOCK_ILIMIT report only, and HW_LOCK_ILIMIT disabled.

7.3.24.8.1 HW_LOCK_ILIMIT Latched Shutdown (HW_LOCK_ILIMIT_MODE = 00xb or 010b)

When a HW_LOCK_ILIMIT event happens in this mode, the status of MOSFET will be configured by HW_LOCK_ILIMIT_MODE and nFAULT is driven low. Status of MOSFETs during HW_LOCK_ILIMIT:

- MTR_LCK_MODE = 000b: All external MOSFETs are turned OFF, the gate driver outputs pulled low.
- MTR_LCK_MODE = 001b or 010b: All low-side MOSFETs (gate driver outputs) are turned ON.

The CONTROLLER_FAULT and HW_LOCK_ILIMIT bits are set to 1b in the fault status registers. Normal operation resumes (gate driver operation and the nFAULT pin is released) when the HW_LOCK_ILIMIT condition clears and a clear fault command is issued through the CLR_FLT bit.

7.3.24.8.2 HW_LOCK_ILIMIT Automatic recovery (HW_LOCK_ILIMIT_MODE = 011b or 10xb)

When a HW_LOCK_ILIMIT event happens in this mode, the status of MOSFET will be configured by HW_LOCK_ILIMIT_MODE and nFAULT is driven low. Status of MOSFET during HW_LOCK_ILIMIT:

- MTR_LCK_MODE = 011b: All external MOSFETs are turned OFF, the gate driver outputs pulled low.
- MTR_LCK_MODE = 100b or 101b: All low-side MOSFETs (gate driver outputs) are turned ON.

The CONTROLLER_FAULT and HW_LOCK_ILIMIT bits are set to 1b in the fault status registers. Normal operation resumes automatically (gate driver operation and the nFAULT pin is released) after the t_{LCK_RETRY} (configured by LCK_RETRY) time lapses. The CONTROLLER_FAULT and HW_LOCK_ILIMIT bits are reset to 0b after the t_{LCK_RETRY} period expires.

7.3.24.8.3 HW_LOCK_ILIMIT Report Only (HW_LOCK_ILIMIT_MODE = 110b)

No protective action is taken when a HW_LOCK_ILIMIT event happens in this mode. The hardware lock detection current limit event is reported by setting the CONTROLLER_FAULT and HW_LOCK_ILIMIT bits to 1b in the fault status registers and nFAULT is pulled low. The gate drivers continue to operate. The external controller manages this condition by acting appropriately. The reporting clears when the HW_LOCK_ILIMIT condition clears and a clear fault command is issued through the CLR_FLT bit.

7.3.24.8.4 HW_LOCK_ILIMIT Disabled (HW_LOCK_ILIMIT_MODE = 111b)

No action is taken when a HW_LOCK_ILIMIT event happens in this mode.

7.3.24.9 Lock Detection Current Limit (LOCK_ILIMIT)

The lock detection current limit function provides a configurable threshold for limiting the current to prevent damage to the system. The MCF8329HS continuously monitors the output of the current sense amplifier (CSA) through the ADC. If at any time, any phase current exceeds LOCK_ILIMIT for a time longer than t_{LCK_ILIMIT} , a LOCK_ILIMIT event is recognized and action is taken according to LOCK_ILIMIT_MODE. The threshold is set through LOCK_ILIMIT and the t_{LCK_ILIMIT} is set through LOCK_ILIMIT_DEG. LOCK_ILIMIT_MODE can be set to four different modes: LOCK_ILIMIT latched shutdown, LOCK_ILIMIT automatic retry, LOCK_ILIMIT report only and LOCK_ILIMIT disabled.

7.3.24.9.1 LOCK_ILIMIT Latched Shutdown (LOCK_ILIMIT_MODE = 00xb or 010b)

When a LOCK_ILIMIT event happens in this mode, the status of external MOSFETs will be configured by LOCK_ILIMIT_MODE and nFAULT is driven low. Status of external MOSFETs driven from MCF8329HS during LOCK_ILIMIT:

- MTR_LCK_MODE = 000b: All external MOSFETs are turned OFF, the gate driver outputs pulled low.
- MTR_LCK_MODE = 001b or 010b: All low-side MOSFETs (gate driver outputs) are turned ON.

The CONTROLLER_FAULT and LOCK_ILIMIT bits are set to 1b in the fault status registers. Normal operation resumes (gate driver operation and the nFAULT pin is released) when the LOCK_ILIMIT condition clears and a clear fault command is issued through the CLR_FLT bit.

7.3.24.9.2 LOCK_ILIMIT Automatic Recovery (LOCK_ILIMIT_MODE = 011b or 10xb)

When a LOCK_ILIMIT event happens in this mode, the status of external MOSFETs will be configured by LOCK_ILIMIT_MODE and nFAULT is driven low. Status of external MOSFETs driven from MCF8329HS during LOCK_ILIMIT:

- MTR_LCK_MODE = 011b: All external MOSFETs are turned OFF, the gate driver outputs pulled low.
- MTR_LCK_MODE = 100b or 101b: All low-side MOSFETs (gate driver outputs) are turned ON.

The CONTROLLER_FAULT and LOCK_ILIMIT bits are set to 1b in the fault status registers. Normal operation resumes automatically (gate driver operation and the nFAULT pin is released) after the t_{LCK_RETRY} (configured by LCK_RETRY) time lapses. The CONTROLLER_FAULT and LOCK_ILIMIT bits are reset to 0b after the t_{LCK_RETRY} period expires.

7.3.24.9.3 LOCK_ILIMIT Report Only (LOCK_ILIMIT_MODE = 110b)

No protective action is taken when a LOCK_ILIMIT event happens in this mode. The lock detection current limit event is reported by setting the CONTROLLER_FAULT and LOCK_ILIMIT bits to 1b in the fault status registers and nFAULT is pulled low. The gate drivers continue to operate. The external controller manages this condition by acting appropriately. The reporting clears when the LOCK_ILIMIT condition clears and a clear fault command is issued through the CLR_FLT bit.

7.3.24.9.4 LOCK_ILIMIT Disabled (LOCK_ILIMIT_MODE = 111b)

No action is taken when a LOCK_ILIMIT event happens in this mode.

7.3.24.10 Motor Lock (MTR_LCK)

The MCF8329HS continuously checks for different motor lock conditions (see [Motor Lock Detection](#)) during motor operation. When one of the enabled lock condition happens, a MTR_LCK event is recognized and action is taken according to the MTR_LCK_MODE.

MCF8329HS locks can be enabled or disabled individually and retry times can be configured through LCK_RETRY. MTR_LCK_MODE bit can operate in four different modes: MTR_LCK latched shutdown, MTR_LCK automatic retry, MTR_LCK report only and MTR_LCK disabled.

7.3.24.10.1 MTR_LCK Latched Shutdown (MTR_LCK_MODE = 00xb or 010b)

When a MTR_LCK event happens in this mode, the status of external MOSFETs will be configured by MTR_LCK_MODE and nFAULT is driven low. Status of external MOSFETs during MTR_LCK:

- MTR_LCK_MODE = 000b: All external MOSFETs are turned OFF, the gate driver outputs pulled low.
- MTR_LCK_MODE = 001b or 010b: All low-side MOSFETs (gate driver outputs) are turned ON.

The CONTROLLER_FAULT, MTR_LCK and respective motor lock condition bits are set to 1b in the fault status registers. Normal operation resumes (gate driver operation and the nFAULT pin is released) when the MTR_LCK condition clears and a clear fault command is issued through the CLR_FLT bit.

7.3.24.10.2 MTR_LCK Automatic Recovery (MTR_LCK_MODE = 011b or 10xb)

When a MTR_LCK event happens in this mode, the status of MOSFETs will be configured by MTR_LCK_MODE and nFAULT is driven low. Status of MOSFETs during MTR_LCK:

- MTR_LCK_MODE = 011b: All external MOSFETs are turned OFF, the gate driver outputs pulled low.
- MTR_LCK_MODE = 100b or 101b: All low-side MOSFETs (gate driver outputs) are turned ON.

The CONTROLLER_FAULT, MTR_LCK and respective motor lock condition bits are set to 1b in the fault status registers. Normal operation resumes automatically (gate driver operation and the nFAULT pin is released) after the t_{LCK_RETRY} (configured by LCK_RETRY) time lapses. The CONTROLLER_FAULT, MTR_LCK and respective motor lock condition bits are reset to 0b after the t_{LCK_RETRY} period expires.

7.3.24.10.3 MTR_LCK Report Only (MTR_LCK_MODE = 110b)

No protective action is taken when a MTR_LCK event happens in this mode. The motor lock event is reported by setting the CONTROLLER_FAULT, MTR_LCK and respective motor lock condition bits to 1b in the fault status registers and nFAULT pin is pulled low. The gate drivers continue to operate. The external controller manages this condition by acting appropriately. The reporting clears when the MTR_LCK condition clears and a clear fault command is issued through the CLR_FLT bit.

7.3.24.10.4 MTR_LCK Disabled (MTR_LCK_MODE = 111b)

No action is taken when a MTR_LCK event happens in this mode.

7.3.24.11 Motor Lock Detection

The MCF8329HS provides different lock detect mechanisms to determine if the motor is in a locked state. Multiple detection mechanisms work together to ensure the lock condition is detected quickly and reliably. In addition to detecting if there is a locked motor condition, the MCF8329HS can also identify and take action if there is no motor connected to the system. Each of the lock detect mechanisms and the no-motor detection can be disabled by their respective register bits.

7.3.24.11.1 Lock 1: Abnormal Speed (ABN_SPEED)

MCF8329HS monitors the speed continuously and at any time the speed exceeds LOCK_ABN_SPEED, an ABN_SPEED lock event is recognized and action is taken according to the MTR_LCK_MODE.

The threshold is set through the LOCK_ABN_SPEED register. ABN_SPEED lock can be enabled/disabled by LOCK1_EN.

7.3.24.11.2 Lock 2: Abnormal BEMF (ABN_BEMF)

MCF8329HS estimates back-EMF in order to run motor optimally in closed loop. This estimated back-EMF is compared against the expected back-EMF calculated using the estimated speed and the BEMF constant. Whenever motor is stalled the estimated back-EMF is inaccurate due to lower back-EMF at low speed. When the difference between estimated and expected back-EMF exceeds ABNORMAL_BEMF_THR, an abnormal BEMF fault is triggered and action is taken according to the MTR_LCK_MODE.

ABN_BEMF lock can be enabled/disabled by LOCK2_EN.

7.3.24.11.3 Lock3: No-Motor Fault (NO_MTR)

The MCF8329HS continuously monitors phase currents on all three phases; if any phase current stays below NO_MTR_THR for 500ms during open loop, a NO_MTR event is recognized. The response to the NO_MTR event is configured through MTR_LCK_MODE. NO_MTR lock can be enabled/disabled by LOCK3_EN.

Note

For a reliable detection of no-motor fault, ensure that the open loop time is sufficiently higher than 500ms.

7.3.24.12 EEPROM Fault

MCF8329HS provides an EEPROM fault detection feature to prevent device operation when there is EEPROM data mismatch due to an interrupted EEPROM write (UVLO during EEPROM write), EEPROM aging etc., MCF8329HS implements a CRC and parity check whenever an EEPROM read command is issued - if there is a CRC or parity mismatch, an EEPROM fault is recognized and action taken according to EEP_FAULT_MODE. If EEP_FAULT_MODE is set to 0b, nFAULT is pulled low, the FETs are in Hi-Z and the CONTROLLER_FAULT and EEPROM_ERR_STATUS bits are set to 1b until the fault condition is cleared by writing 1b to CLR_FLT. If EEP_FAULT_MODE is set to 1b, this fault is reported on nFAULT pin and CONTROLLER_FAULT, EEPROM_ERR_STATUS bits are set to 1b but the device operation (FETs) continues normally. The fault reporting can be cleared (nFAULT pin is released, CONTROLLER_FAULT, EEPROM_ERR_STATUS set to 0b) by writing 1b to CLR_FLT.

Note

- An EEPROM read command is internally issued by the device at every power-up/wake-up to load the configurations from EEPROM into the shadow/RAM registers.
- A successful EEPROM write can fix EEPROM data mismatch. When an EEPROM write is successfully completed, MCF8329HS automatically updates the internal CRC for the new EEPROM values - this updated CRC is used during subsequent EEPROM read commands to check for EEPROM data mismatch.
- An EEPROM write can happen even when the device is in fault state.

7.3.24.13 I²C CRC Fault

MCF8329HS provides I²C CRC fault detection feature to detect errors in an I²C transaction. MCF8329HS implements a CRC check on the entire I²C packet when I²C CRC is enabled - if there is a CRC mismatch, an I²C CRC fault is recognized and action taken according to CRC_ERR_MODE. If CRC_ERR_MODE is set to 0b, nFAULT is pulled low, the FETs are in Hi-Z and the CONTROLLER_FAULT and I2C_CRC_FAULT_STATUS bits are set to 1b until the fault condition is cleared by writing 1b to CLR_FLT. If EEP_FAULT_MODE is set to 1b, this fault is reported on nFAULT pin and CONTROLLER_FAULT, I2C_CRC_FAULT_STATUS bits are set to 1b but the device operation (FETs) continues normally. The fault reporting can be cleared (nFAULT pin is released, CONTROLLER_FAULT, I2C_CRC_FAULT_STATUS set to 0b) by writing 1b to CLR_FLT.

7.3.24.14 Maximum PVDD (Overvoltage) Protection

MCF8329HS provides a configurable PVDD overvoltage protection. The PVDD level at which MCF8329HS triggers the overvoltage fault is set by MAX_VM_MOTOR and the fault response to PVDD overvoltage is set by MAX_VM_MODE. If MAX_VM_MODE is set to 0b, PVDD overvoltage fault (at MAX_VM_MOTOR) is latched and the FETs are in Hi-Z until the fault condition is cleared by writing 1b to CLR_FLT bit. If MAX_VM_MODE is set to 1b, PVDD overvoltage fault (at MAX_VM_MOTOR) automatically clears and the device starts motor operation once PVDD < (MAX_VM_MOTOR - VOLTAGE_HYSTERESIS).

7.3.24.15 Minimum PVDD (Undervoltage) Protection

MCF8329HS provides a configurable PVDD undervoltage protection. The PVDD level at which MCF8329HS triggers the undervoltage fault is set by MIN_VM_MOTOR and the fault response to PVDD undervoltage is set by MIN_VM_MODE. If MIN_VM_MODE is set to 0b, PVDD undervoltage fault (at MIN_VM_MOTOR) is latched and the FETs are in Hi-Z until the fault condition is cleared by writing 1b to CLR_FLT bit. If MIN_VM_MODE is set to 1b, PVDD undervoltage fault (at MIN_VM_MOTOR) automatically clears and the device starts motor operation once PVDD > (MIN_VM_MOTOR + VOLTAGE_HYSTERESIS).

7.3.24.16 MPET Faults

An error during BEMF constant measurement is reported using MPET_BEMF_FAULT. This fault gets triggered when the measured back EMF is less than the threshold set in STAT_DETECT_THR. One example of such fault scenario can be the motor stall while running in open loop due to incorrect open loop configuration used.

7.3.24.17 Dry Run Detection

MCF8329HS provides the option of dry run detection when pumps are operating with insufficient fluid. Dry run is a dangerous operating condition that can damage pumps - timely detection and preventive action is necessary to protect pumps. Dry run is characterized by the motor operating continuously at a lower current/power than when operating with sufficient fluid. Dry run detection is enabled when DRY_RUN_MODE ≠ 00b. The threshold speed for dry run detection is configured by DRY_RUN_SPEED_THR - even when enabled, dry run detection is active only when motor speed is higher than DRY_RUN_SPEED_THR. The q-axis current threshold (I_{DRY_RUN}) for detecting dry run can either be fixed across motor speed (DRY_RUN_ILIM_MODE = 0b) or variable (DRY_RUN_ILIM_MODE = 1b). I_{DRY_RUN} is fixed to DRY_RUN_ILIM when DRY_RUN_ILIM_MODE = 0b. When DRY_RUN_ILIM_MODE = 1b, I_{DRY_RUN} varies with motor speed as shown in [Figure 7-51](#). The I_q current must be lower than I_{DRY_RUN} for a deglitch time interval set by DRY_RUN_TDEG before dry run fault is triggered as shown in [Figure 7-50](#).

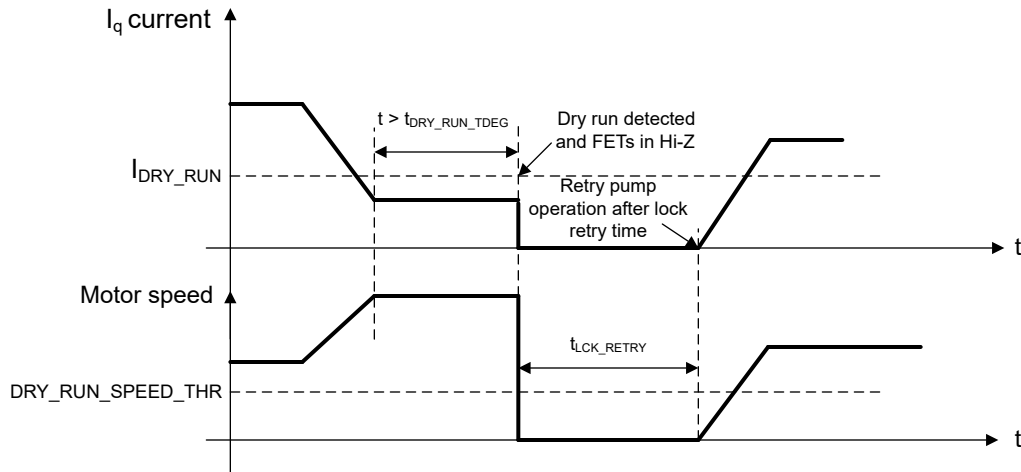

Figure 7-50. Dry Run Detection

On detection of dry run condition, action is taken based on DRY_RUN_MODE. If DRY_RUN_MODE is set to 11b, all external FETs are turned off (PWMs are pulled low), nFAULT is pulled low, CONTROLLER_FAULT, DRY_RUN bits are set to 1b until a clear fault command is issued by external MCU through the CLR_FLT bit. If DRY_RUN_MODE is set to 10b, all external FETs are turned off (PWMs are pulled low), nFAULT is pulled low - normal operation resumes automatically (gate driver operation and the nFAULT pin is released) after the t_{LCK_RETRY} (configured by LCK_RETRY) time lapses. The CONTROLLER_FAULT and DRY_RUN bits are reset to 0b after the t_{LCK_RETRY} period expires.

MCF8329HS provides the option to vary I_{DRY_RUN} as a function of motor speed to detect dry run in pumps that can operate at multiple speeds (or flow rates) during normal operation. User must set DRY_RUN_ILIM to the expected I_q current at 100% speed and DRY_RUN_ILIM_FIFTY_PERCENT_SPEED to the expected I_q current at 50% speed. MCF8329HS uses DRY_RUN_ILIM as I_{DRY_RUN} when motor is at 100% speed and DRY_RUN_ILIM_FIFTY_PERCENT_SPEED as I_{DRY_RUN} when motor is at 50% speed. When motor is operating at other speeds, MCF8329HS extrapolates I_{DRY_RUN} as shown in [Figure 7-51](#).

Note

TI recommends subtracting 5-10% from expected I_q current for setting DRY_RUN_ILIM and DRY_RUN_ILIM_FIFTY_PERCENT_SPEED to avoid false dry run faults (due to I_{DRY_RUN} being set too high).

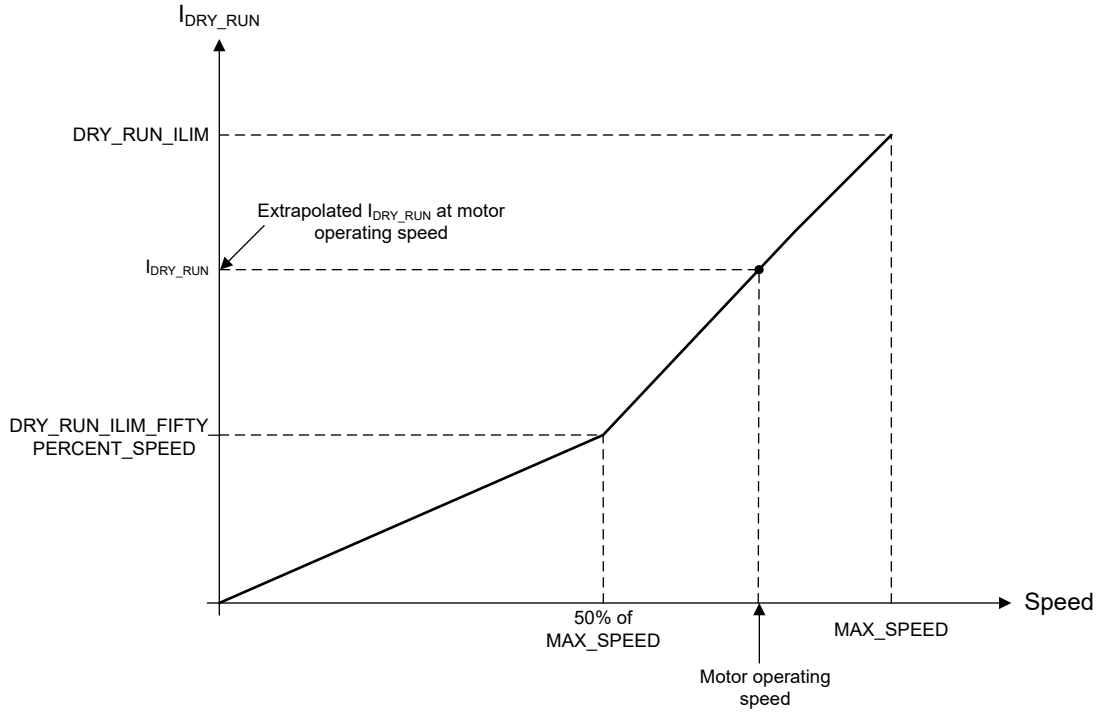

Figure 7-51. Variable current threshold ($I_{\text{DRY_RUN}}$) for dry run detection

7.4 Device Functional Modes

7.4.1 Functional Modes

7.4.1.1 Sleep Mode

In sleep mode all gate drivers are disabled, the GVDD regulator is disabled, the AVDD regulator is disabled, the sense amplifier, and the I²C bus are disabled. The device can be configured to enter sleep (instead of standby) mode by configuring DEV_MODE to 1b. The entry and exit from sleep state as described in [Table 7-8](#).

Table 7-8. Conditions to Enter or Exit Sleep Modes

INPUT REFERENCE COMMAND MODE	ENTER SLEEP, DEV_MODE = 1b	EXIT FROM SLEEP	ENTER STANDBY, DEV_MODE = 0b	EXIT FROM STANDBY
Analog input at SPEED/WAKE pin	$V_{\text{SPEED/WAKE}} < V_{\text{EN_SL}}$ for $t_{\text{DET_SL_ANA}}$ if SLEEP_ENTRY_TIME = 00b or 01b; for $t_{\text{DET_SL_PWM}}$ if SLEEP_ENTRY_TIME = 10b or 11b	$V_{\text{SPEED/WAKE}} > V_{\text{EX_SL}}$	$V_{\text{SPEED/WAKE}} < V_{\text{EN_SB}}$	$V_{\text{SPEED/WAKE}} > V_{\text{EX_SB}}$
Analog input at DACOUT/SOx/SPEED_ANA pin	$V_{\text{SPEED/WAKE}} < V_{\text{IL}}$	$V_{\text{SPEED/WAKE}} > V_{\text{IH}}$	$V_{\text{SPEED/WAKE}} < V_{\text{IL}}$ or $V_{\text{DACOUT/SOx/SPEED_ANA}} < V_{\text{EN_SB}}$	$V_{\text{SPEED/WAKE}} > V_{\text{IH}}$ and $V_{\text{DACOUT/SOx/SPEED_ANA}} > V_{\text{EX_SB}}$
PWM	$V_{\text{SPEED/WAKE}} < V_{\text{IL}}$ for $t_{\text{DET_SL_PWM}}$	$V_{\text{SPEED/WAKE}} > V_{\text{IH}}$ for $t_{\text{DET_PWM}}$	Duty _{SPEED/WAKE} < Duty _{EN_SB} for $t_{\text{DET_SL_PWM}}$	Duty _{SPEED/WAKE} > Duty _{EX_SB} for $t_{\text{DET_PWM}}$
Frequency	$V_{\text{SPEED/WAKE}} < V_{\text{IL}}$ for $t_{\text{DET_SL_PWM}}$	$V_{\text{SPEED/WAKE}} > V_{\text{IH}}$ for $t_{\text{DET_PWM}}$	Freq _{SPEED/WAKE} < Freq _{EN_SB} for $t_{\text{DET_SL_PWM}}$	Freq _{SPEED/WAKE} > Freq _{EX_SB} for $t_{\text{DET_PWM}}$
I ² C	$V_{\text{SPEED/WAKE}} < V_{\text{IL}}$ and DIGITAL_SPEED_CTRL = 0h for $t_{\text{DET_SL_PWM}}$	$V_{\text{SPEED/WAKE}} > V_{\text{IH}}$	DIGITAL_SPEED_CTRL < DIGITAL_SPEED_CTRL _{EN_SB}	DIGITAL_SPEED_CTRL > DIGITAL_SPEED_CTRL _{EX_SB}

Note

During power-up and power-down of the device, the nFAULT pin is held low as the internal regulators are disabled. After the regulators have been enabled, the nFAULT pin is automatically released.

7.4.1.2 Standby Mode

In standby mode the gate driver, AVDD LDO and I²C bus are active. The device can be configured to enter standby mode by configuring DEV_MODE to 0b. The device enters standby mode when the reference command after the profiler is zero.

The thresholds for entering and exiting standby mode in different input modes are as follows,

Table 7-9. Standby Mode Entry/Exit Thresholds

Control Input Source	Standby entry/exit thresholds	REF_PROFILE_CONFIG = 00b	REF_PROFILE_CONFIG ≠ 00b
Analog	$V_{\text{EN_SB}}$ or $V_{\text{EX_SB}}$	$V_{\text{EX_SB}} = \text{MIN_DUTY} \times V_{\text{ANA_FS}}$; $V_{\text{EN_SB}} = (\text{MIN_DUTY} - \text{DUTY_HYS}) \times V_{\text{ANA_FS}}$	REF_X = 1% of MAX_SPEED or MAX_POWER or ILIMIT or MODULATION INDEX
PWM	Duty _{EN_SB} or Duty _{EX_SB}	Duty _{EX_SB} = MIN_DUTY; Duty _{EN_SB} = MIN_DUTY - DUTY_HYS	REF_X = 1% of MAX_SPEED or MAX_POWER or ILIMIT or MODULATION INDEX
I ² C	DIGITAL_SPEED_CTRL _{EN_SB} or DIGITAL_SPEED_CTRL _{EX_SB}	DIGITAL_SPEED_CTRL _{EX_SB} = MIN_DUTY x 32767; DIGITAL_SPEED_CTRL _{EN_SB} = (MIN_DUTY-DUTY_HYS) x 32767)	REF_X = 1% of MAX_SPEED or MAX_POWER or ILIMIT or MODULATION INDEX

Table 7-9. Standby Mode Entry/Exit Thresholds (continued)

Control Input Source	Standby entry/exit thresholds	REF_PROFILE_CONFIG = 00b	REF_PROFILE_CONFIG ≠ 00b
Frequency	Freq _{EN_SB} or Freq _{EX_SB}	Freq _{EX_SB} = MIN_DUTY x INPUT_MAXIMUM_FREQ (subject to minimum of 3Hz); Freq _{EN_SB} = (MIN_DUTY-DUTY_HYS) x INPUT_MAXIMUM_FREQ (subject to minimum of 3Hz)	REF_X = 1% of MAX_SPEED or MAX_POWER or ILIMIT or MODULATION INDEX

7.4.1.3 Fault Reset (CLR_FLT)

In the case of latched faults, the device goes into a partial shutdown state to help protect the power MOSFETs and system. When the fault condition clears, the device can go to the operating state again by setting the CLR_FLT to 1b.

7.5 External Interface

7.5.1 DRVOFF - Gate Driver Shutdown Functionality

When DRVOFF is driven high, the gate driver goes into shutdown. DRVOFF bypasses the digital control logic inside the device, and is connected directly to the gate driver output (see Figure 7-52). This pin provides a mechanism for externally monitored faults to disable gate driver by directly bypassing the internal control logic. When the MCF8329HS detects logic high on the DRVOFF pin, the device disables the gate driver and puts the device into pull down mode (see Figure 7-53). The gate driver shutdown sequence proceeds as shown in Figure 7-53. When the gate driver initiates the shutdown sequence, the active driver pull down is applied at I_{SINK} current for the t_{SD_SINK_DIG} time, after which the gate driver moves to passive pull down mode.

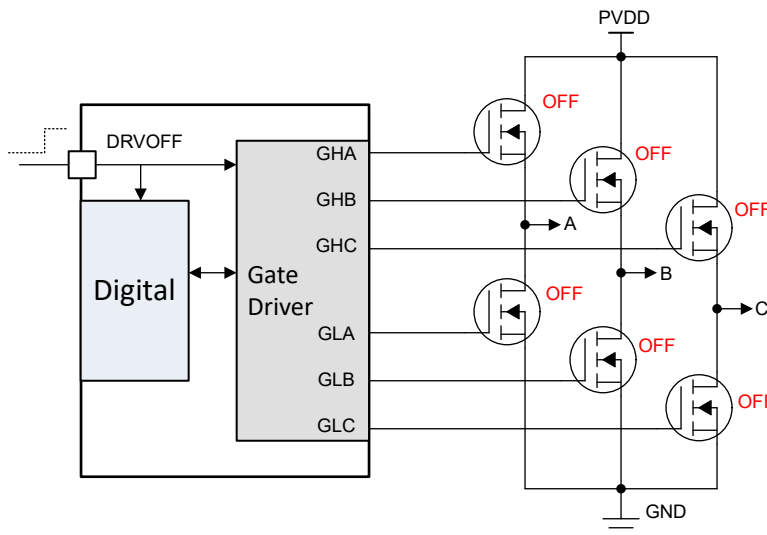

Figure 7-52. DRVOFF Gate Driver Output State

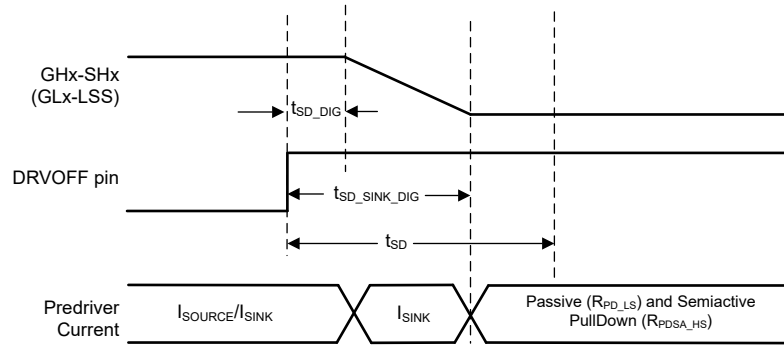

Figure 7-53. Gate Driver Shutdown Sequence

Note

Pulling the DRVOFF pin high does not cause the device to enter sleep or standby mode and the digital core is still active. The DRVOFF status is reported on DRV_OFF bit and has a latency of up to 200ms between the pin status change to DRV_OFF bit status update. The DRVOFF is not reported on nFAULT pin, however nFAULT pin can go low if a motor fault happens when DRVOFF goes to logic high during motor operation. When DRVOFF is pulled from high to low, MCF8329HS execute motor start sequence (with a latency up to 200ms after pulling DRVOFF pin low) as described in [Section 7.3.10](#).

7.5.2 DAC outputs

MCF8329HS has 12-bit DACs which output analog voltage equivalent of digital variables on DACOUT pin with resolution of 12 bits and maximum voltage is 3V. Signals available on DACOUT pins is useful in tracking algorithm variables in real-time and can be used for tuning speed controller or motor acceleration time. The address for variables for DACOUT is configured using DACOUT_VAR_ADDR.

Note

The DACOUT value for a selected variable can be inaccurate during fault, brake, or HiZ states.

7.5.3 Current Sense Amplifier Output

MCF8329HS can provide the built-in current sense amplifier's output on the DACOUT/SOx/SPEED_ANA pin by configuring DACOUT/SOx/SPEED_ANA.

7.5.4 Oscillator Source

MCF8329HS has a built-in oscillator that is used as the clock source for all digital peripherals and timing measurements. Default configuration for MCF8329HS is to use the internal oscillator and it is sufficient to drive the motor without need for any external crystal or clock sources.

In case MCF8329HS does not meet accuracy requirements of timing measurement or speed loop, then MCF8329HS has an option to support an external clock reference.

In order to improve EMI performance, MCF8329HS provides the option of modulating the clock frequency by enabling Spread Spectrum Modulation (SSM) through SPREAD_SPECTRUM_MODULATION_DIS.

Note

Spread spectrum modulation is not available (irrespective of SPREAD_SPECTRUM_MODULATION_DIS) when CLOCK_FREQUENCY is set to 00b (HIGH).

7.5.4.1 Clock (Internal Oscillator) Frequency

MCF8329HS provides configurable clock (internal oscillator) frequency to optimize between device operating current and maximum motor speed/PWM switching frequency. [Table 7-10](#) shows the relationship between clock frequency, PWM switching frequency and maximum motor speed.

Table 7-10. Maximum motor speed vs PWM switching frequency vs clock frequency

PWM_FREQ_OUT	PWM Switching Frequency (kHz)	Maximum Motor Speed (Hz)		
		CLOCK_FREQUENCY = HIGH	CLOCK_FREQUENCY = MEDIUM	CLOCK_FREQUENCY = LOW
0000b	10	1200	1200	1000
0001b	15	1800	1800	900
0010b	20	2500	1200	1000
0011b	25	1500	1500	1000
0100b	30	1800	1800	1000
0101b	35	2150	1450	1000
0110b	40	2500	1600	1000
0111b	45	1800	1800	1000
1000b	50	2000	1500	1000
1001b	55	2300	1700	Not Applicable
1010b	60	2500	1500	Not Applicable
1011b	65	2000	1600	Not Applicable
1100b	70	2100	1750	Not Applicable
1101b	75	2300	1500	Not Applicable
1110b	80	2000	1600	Not Applicable

Note

Any change to CLOCK_FREQUENCY setting can take effect only after writing to EEPROM followed by a power recycle.

Clock frequency impacts the applied dead time configured by DIG_DEAD_TIME. [Table 7-11](#) shows the applied dead time as a function of clock frequency.

Table 7-11. Dead time vs clock frequency

DIG_DEAD_TIME	Dead time (ns)		
	CLOCK_FREQUENCY = HIGH	CLOCK_FREQUENCY = MEDIUM	CLOCK_FREQUENCY = LOW
0000b	0	0	0
0001b	75	50	75
0010b	150	100	110
0011b	150	150	150
0100b	225	200	225
0101b	300	250	260
0110b	300	300	300
0111b	375	350	375
1000b	450	400	450
1001b	450	450	450
1010b	525	500	520
1011b	600	600	600
1100b	750	700	750
1101b	900	800	750
1110b	1050	1000	750

7.5.4.2 External Clock Source

Speed loop accuracy of MCF8329HS over wide operating temperature range can be improved by providing more accurate optional clock reference on EXT_CLK pin as shown in Figure 7-54. EXT_CLK is used to calibrate internal clock oscillator and match the accuracy of the external clock. External clock source can be selected by configuring CLK_SEL to 11b and setting EXT_CLK_EN to 1b. The external clock source frequency can be configured through EXT_CLK_CONFIG.

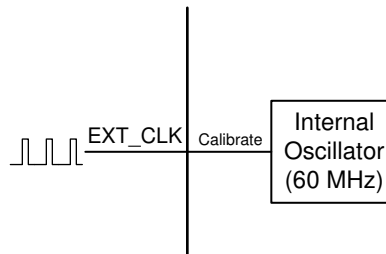

Figure 7-54. External Clock Reference

Note

- External clock is optional and can be used when higher clock accuracy is needed. MCF8329HS is always power up using the internal oscillator in all modes.
- When EXT_CLK_EN is set to 1b, 1-Hall based sensed operation is not supported (even when HALL_EN is set to 1b) since the Hall input functionality is mux'ed on the same GPIO pin as EXT_CLK.

7.5.5 External Watchdog

MCF8329HS provides an external watchdog feature to monitor the health of an external MCU - EXT_WD_EN bit must be set to 1b to enable the external watchdog. When this feature is enabled, the device waits for a tickle (WATCHDOG_TICKLE set to 1b over I²C) from the external watchdog input for a configured time interval; if the time interval between two consecutive tickles is longer than the configured watchdog wait time, a watchdog fault is triggered. The watchdog fault response can be configured using EXT_WD_FAULT_MODE as shown in Table 7-7. When LIMP_HOME_EN is set to 0b (limp home mode disabled), fault response is either report only (FETs active and driving motor at input reference) or latched (FETs in Hi-Z) depending on EXT_WD_FAULT_MODE. The latched fault can be cleared by writing 1b to CLR_FLT or by issuing a tickle over I²C. When LIMP_HOME_EN is set to 1b (limp home mode enabled), fault response is either the input reference latched to current value or latched to REF_OFF1 depending on EXT_WD_FAULT_MODE - MCF8329HS operates the motor at the latched input reference till 1b is written to CLR_FLT or a tickle is issued over I²C. Once the watchdog fault is cleared (by writing 1b to CLR_FLT or by issuing a tickle over I²C), MCF8329HS exits the limp home mode and drives the motor to the input reference from the reference source configured by SPEED_MODE (analog, PWM, I²C or frequency). When a watchdog timeout occurs, WATCHDOG_FAULT bit is set to 1b. In case the next tickle arrives before the configured time interval elapses, the watchdog timer is reset and the timer begins to wait for the next tickle. This can be used to continuously monitor the health of an external MCU (which is the external watchdog input) and place the MCF8329HS in a known state, in case the external MCU is in a fault/hang state.

The external watchdog input is via the I²C interface (EXT_WD_INPUT_MODE is always be set to 0b). The time interval between two tickles to trigger a watchdog fault is configured by EXT_WD_CONFIG; there are 4 time settings - 1, 2, 5 and 10s.

Note

1. When limp home mode is enabled and a watchdog fault is active, the device does not enter sleep mode (irrespective of EXT_WD_FAULT_MODE), even when sleep mode is configured and all sleep entry conditions are met.
 2. Watchdog must be disabled by setting EXT_WD_EN to 0b before changing EXT_WD_CONFIG configuration.
-

7.6 EEPROM access and I²C interface

7.6.1 EEPROM Access

MCF8329HS has 1024 bits (16 rows of 64 bits each) of EEPROM, which are used to store the motor configuration parameters. Erase operations are row-wise (all 64 bits are erased in a single erase operation), but 32-bit write and read operations are supported. EEPROM can be written and read using the I²C serial interface but erase cannot be performed using I²C serial interface. The shadow/RAM registers corresponding to the EEPROM are located at addresses 0x000080-0x0000AE.

Note

MCF8329HS allows EEPROM write and read operations only when the motor is not spinning.

7.6.1.1 EEPROM Write

Note

- EEPROM write must be issued only when device is in idle or fault state (motor not driven by device). PVDD must be $\geq 6V$ throughout the EEPROM write process to maintain that all power rails (AVDD and DVDD) stay within data sheet specifications and EEPROM write is never interrupted due to any UVLO condition.
 - TI does not recommend writing to EEPROM during every power-up/wake-up due to aging/write cycle limitations on number of EEPROM writes (20000 write cycles at $T_J = 85^\circ C$). Repetitive register settings change can be done at shadow/RAM registers (0x000080-0x0000AE); only default configurations need to be written to EEPROM (at first power-up)
-

In MCF8329HS, EEPROM write procedure is as follows,

1. Write register 0x000080 (ISD_CONFIG) with ISD and reverse drive configuration like resync enable, reverse drive enable, stationary detect threshold, reverse drive hand-off threshold and so forth.
2. Write register 0x000082 (REV_DRIVE_CONFIG) with reverse drive and active brake configuration like reverse drive open loop acceleration, active brake current limit, Kp, Ki values and so forth.
3. Write register 0x000084 (MOTOR_STARTUP1) with motor start-up configuration like start-up method, IPD parameters, align parameters and so forth.
4. Write register 0x000086 (MOTOR_STARTUP2) with motor start-up configuration like open loop acceleration, open loop current limit, first cycle frequency and so forth.
5. Write register 0x000088 (CLOSED_LOOP1) with motor control configuration like closed loop acceleration, overmodulation enable, PWM frequency, FG signal configurations and so forth.
6. Write register 0x00008A (CLOSED_LOOP2) with motor control configuration like motor winding resistance and inductance, motor stop options, brake speed threshold and so forth.
7. Write register 0x00008C (CLOSED_LOOP3) with motor control configuration like motor BEMF constant, current loop Kp, Ki and so forth.
8. Write register 0x00008E (CLOSED_LOOP4) with motor control configuration like speed loop Kp, Ki and maximum speed.
9. Write register 0x000090 (FAULT_CONFIG1) with fault control configuration software and hardware current limits and actions, retry times and so forth.
10. Write register 0x000092 (FAULT_CONFIG2) with fault control configuration like hardware current limit actions, OV, UV limits and actions, abnormal speed level, no motor threshold etc.
11. Write registers 0x000094 – 0x00009E (SPEED_PROFILES1-6) with speed profile configuration like profile type, duty cycle, speed clamp level, duty cycle clamp level etc.
12. Write register 0x0000A0 (INT_ALGO_1) with miscellaneous configuration like ISD run time, stop time and timeout etc.
13. Write register 0x0000A2 (INT_ALGO_2) with miscellaneous configuration like flux weakening Kp, Ki, active brake current slew rate, closed loop slow acceleration etc.
14. Write registers 0x0000A4 (PIN_CONFIG) with pin configuration for speed input mode (analog or PWM or Freq or I²C), Brake input, FG during idle and fault state config and so forth.

15. Write registers 0x0000A6 and 0x0000A8 (DEVICE_CONFIG1 and DEVICE_CONFIG2) with device configuration like device mode, dynamic voltage gain enable, I²C target address and so forth.
16. Write register 0x0000AA (PERI_CONFIG1) with peripheral configuration like dead time, SSM enable and so forth.
17. Write registers 0x0000AC and 0x0000AE (GD_CONFIG1 and GD_CONFIG2) with gate driver configuration like slew rate, CSA gain, VDS level, mode and so forth.
18. Write 0x8A500000 into register 0x0000EA to write the shadow register(0x000080-0x0000AE) values into the EEPROM.
19. Wait for 750ms for the EEPROM write operation to complete.
20. After 750ms, read 0x0000EA register to maintain the register is reset to 0x0. This confirms that the EEPROM write process has been completed successfully.

Steps 1-17 can be selectively executed based on registers/parameters that need to be modified. After all shadow/RAM registers have been updated with the required values, steps 18-20 must be executed to write the contents of the shadow/RAM registers into the EEPROM.

Note

EEPROM reserved bit field defaults settings must not be changed. To avoid changing the content of reserved bits, TI recommends using “read-modify-write” sequence to perform EEPROM write operation.

7.6.1.2 EEPROM Read

In MCF8329HS, EEPROM read procedure is as follows,

1. Write 0x40000000 into register 0x0000EA to read the EEPROM data into the shadow/RAM registers (0x000080-0x0000AE).
2. Wait for 100ms for the EEPROM read operation to complete.
3. Read the shadow/RAM register values, one or two registers at a time, using the I²C read command as explained in [Section 7.6.2](#). Shadow register addresses are in the range of 0x000080-0x0000AE. Register address increases in steps of 2 for 32-bit read operation (since each address is a 16-bit location).

7.6.1.3 EEPROM Security

MCF8329HS provides configurable read and write protection to EEPROM registers. The level of protection can be configured using EEPROM_LOCK_MODE as per following list,

- 00b : EEPROM read and write are allowed without a passcode
- 01b : EEPROM read and write need a valid passcode
- 10b : EEPROM read needs a valid passcode; EEPROM write is locked permanently
- 11b : EEPROM read and write are locked permanently

Passcode is a 15-bit field in the EEPROM denoted by EEPROM_LOCK_KEY in the DEVICE_CONFIG1 register. EEPROM_LOCK_KEY is write accessible (when EEPROM_LOCK_MODE is set to 00b or 01b) but not read accessible.

When passcode based read/write protection is enabled (EEPROM_LOCK_MODE set to 01b or 10b), user has to write the passcode set in EEPROM_LOCK_KEY to USER_EEPROM_KEY bitfield after every power-up/wake-up before sending the first EEPROM read/write transaction over I²C. One valid passcode write after power-up/wake-up is sufficient for all subsequent EEPROM read/write transactions as long as there is no power reset, sleep mode entry, digital reset or incorrect passcode write. If an invalid passcode is written, the subsequent EEPROM read/write transactions are rejected - MCF8329HS does not respond to the read/write requests. The read/write protection is applicable to EEPROM as well as the corresponding shadow/RAM locations. The EEPROM_LOCK_MODE as well as the passcode are part of the EEPROM registers and hence same level of read/write protection applies to these bit fields as configured by EEPROM_LOCK_MODE.

7.6.2 I²C Serial Interface

MCF8329HS interfaces with an external MCU over an I²C serial interface. MCF8329HS is an I²C target to be interfaced with a controller. External MCU can use this interface to read/write from/to any non-reserved register in MCF8329HS.

7.6.2.1 I²C Data Word

The I²C data word format is shown in [Table 7-12](#).

Table 7-12. I²C Data Word Format

TARGET_ID	R/W	CONTROL WORD	DATA	CRC-8
A6 - A0	W0	CW23 - CW0	D15 / D31/ D63 - D0	C7 - C0

Target ID and R/W Bit: The first byte includes the 7-bit I²C target ID, followed by the read/write command bit. For every packet in MCF8329HS, the communication protocol starts with writing a 24-bit control word and hence the R/W bit is always 0.

24-bit Control Word: The Target ID/address is followed by a 24-bit control word. The control word format is shown in [Table 7-13](#).

Table 7-13. 24-bit Control Word Format

OP_R/W	CRC_EN	DLEN	MEM_SEC	MEM_PAGE	MEM_ADDR
CW23	CW22	CW21- CW20	CW19 - CW16	CW15 - CW12	CW11 - CW0

Each field in the control word is explained in detail below.

OP_R/W – Read/Write: R/W bit gives information on whether this is a read (1b) transaction or write (0b) transaction. For write transaction, MCF8329HS expects data bytes to be sent after the 24-bit control word. For read transaction, MCF8329HS expects an I²C read request with repeated start or normal start after the 24-bit control word.

CRC_EN – Cyclic Redundancy Check(CRC) Enable: MCF8329HS supports CRC to verify the data integrity. This bit controls whether the CRC feature is enabled or not.

DLEN – Data Length: DLEN field determines the length of the data that is sent by external MCU to MCF8329HS. MCF8329HS I²C protocol supports three data lengths: 16-bit, 32-bit and 64-bit.

Table 7-14. Data Length Configuration

DLEN Value	Data Length
00b	16-bit
01b	32-bit
10b	64-bit
11b	Reserved

MEM_SEC – Memory Section: Each memory location in MCF8329HS is addressed using three separate entities in the control word – Memory Section, Memory Page, Memory Address. Memory Section is a 4-bit field which denotes the memory section to which the memory location belongs like RAM, ROM etc.

MEM_PAGE – Memory Page: Memory page is a 4-bit field which denotes the memory page to which the memory location belongs.

MEM_ADDR – Memory Address: Memory address is the last 12-bits of the address. The complete 22-bit address is constructed internally by MCF8329HS using all three fields – Memory Section, Memory Page, Memory Address. For memory locations 0x000000-0x000800, memory section is 0x0, memory page is 0x0 and memory address is the lowest 12 bits(0x000 for 0x000000, 0x080 for 0x000080 and 0x800 for 0x000800). All relevant memory locations (EEPROM and RAM variables) have MEM_SEC and MEM_PAGE values both corresponding to 0x0. All other MEM_SEC, MEM_PAGE values are reserved and not for external use.

Data Bytes: For a write transaction to MCF8329HS, the 24-bit control word is followed by data bytes. The DLEN field in the control word must correspond with the number of bytes sent in this section. In case of mismatch between number of data bytes and DLEN, the write transaction is discarded.

CRC Byte: If the CRC feature is enabled in the control word, CRC byte has to be sent at the end of a write transaction. Refer to [Section 7.6.2.6](#) for detailed information on CRC byte calculation.

7.6.2.2 I²C Write Transaction

MCF8329HS write transaction over I²C involves the following sequence (see [Figure 7-55](#)).

1. I²C Start condition from the controller to initiate the transaction.
2. Start is followed by the I²C target ID byte, made up of 7-bit target ID along with the R/W bit set to 0b. ACK in yellow box indicates that MCF8329HS has processed the received target ID which has matched with its I²C target ID and therefore will proceed with this transaction. If target ID received does not match with the I²C ID of MCF8329HS, then the transaction is ignored and no ACK is sent by MCF8329HS.
3. The target ID byte is followed by the 24-bit control word sent one byte at a time. Bit 23 in the control word is 0b as it is a write transaction. ACK in blue boxes correspond to acknowledgements sent by MCF8329HS to the controller that the previous byte (of control word) has been received and next byte can be sent.
4. The 24-bit control word is then followed by the data bytes. The number of data bytes sent by the controller depends on the DLEN field in the control word.
 - a. While sending data bytes, the LSB byte is sent first. Refer to [Section 7.6.2.4](#) for more details.
 - b. 16-bit/32-bit write – The data sent is written to the address mentioned in control word.
 - c. 64-bit Write – 64-bit is treated as two successive 32-bit writes. The address mentioned in control word is taken as Addr_1. Addr_2 is internally calculated by MCF8329HS by incrementing Addr_1 by 0x2. A total of 8 data bytes are sent. The first 4 bytes (sent in LSB first) are written to Addr_1 and the next 4 bytes are written to Addr_2.
 - d. ACK in blue box (after every data byte) corresponds to the acknowledgement sent by MCF8329HS to the controller that the previous data byte has been received and next data byte can be sent.
5. If CRC is enabled, the packet ends with a CRC byte. CRC is calculated for the entire packet (Target ID + W bit, Control Word, Data Bytes). MCF8329HS will send an ACK on receiving the CRC byte.
6. I²C Stop condition from the controller to terminate the transaction.

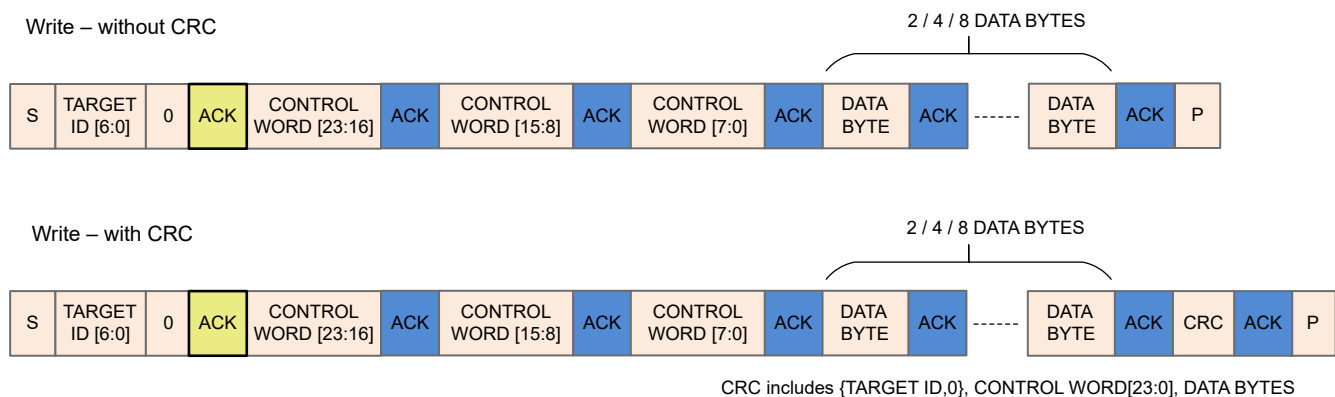

Figure 7-55. I²C Write Transaction Sequence

7.6.2.3 I²C Read Transaction

MCF8329HS read transaction over I²C involves the following sequence (see [Figure 7-56](#)).

1. I²C Start condition from the controller to initiate the transaction.
2. Start is followed by the I²C target ID byte, made up of 7-bit target ID along with the R/W bit set to 0b. ACK (in yellow box) indicates that MCF8329HS has processed the received target ID which has matched with the I²C target ID and therefore proceeds with this transaction. If target ID received does not match with the I²C ID of MCF8329HS, then the transaction is ignored and no ACK is sent by MCF8329HS

3. The target ID byte is followed by the 24-bit control word sent one byte at a time. Bit 23 in the control word is set to 1b as the bit is a read transaction. ACK (in blue boxes) correspond to acknowledgments sent by MCF8329HS to the controller that the previous byte (of control word) has been received and next byte can be sent.
4. The control word is followed by a Repeated Start (RS, start without a preceding stop) or normal Start (P followed by S) to initiate the data (to be read back) transfer from MCF8329HS to I²C controller. RS or S is followed by the 7-bit target ID along with R/W bit set to 1b to initiate the read transaction. MCF8329HS sends an ACK (in grey box after RS) to the controller to acknowledge the receipt of read transaction request.
5. Post acknowledgment of read transaction request, MCF8329HS sends the data bytes on SDA one byte at a time. The number of data bytes sent by MCF8329HS depends on the DLEN field in the control word.
 - a. While sending data bytes, the LSB byte is sent first. Refer to Section 7.6.2.4 for more details.
 - b. 16-bit/32-bit Read – The data from the address mentioned in control word is sent back to the controller.
 - c. 64-bit Read – 64-bit is treated as two successive 32-bit reads. The address mentioned in control word is taken as Addr_1. Addr_2 is internally calculated by MCF8329HS by incrementing Addr_1 by 0x2. A total of 8 data bytes are sent by MCF8329HS. The first 4 bytes (sent in LSB first) are read from Addr_1 and the next 4 bytes are read from Addr_2.
 - d. ACK in orange boxes correspond to acknowledgments sent by the controller to MCF8329HS that the previous byte has been received and next byte can be sent.
6. If CRC is enabled in the control word, then MCF8329HS sends an additional CRC byte at the end. Controller has to read the CRC byte and then send the last ACK (in orange). CRC is calculated for the entire packet (Target ID + W bit, Control Word, Target ID + R bit, Data Bytes).
7. I²C Stop condition from the controller to terminate the transaction.

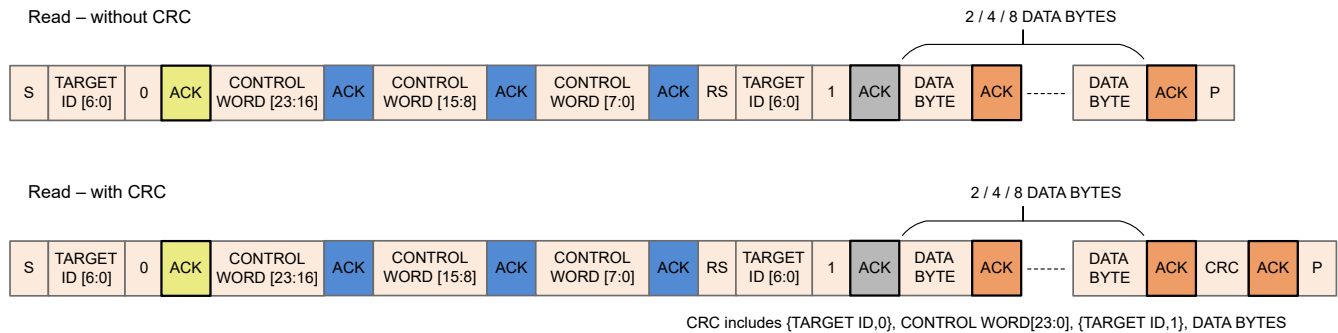

Figure 7-56. I²C Read Transaction Sequence

7.6.2.4 Examples of I²C Communication Protocol Packets

All values used in this example section are in hex format. I²C target ID used in the examples is 0x01.

Example for 32-bit Write Operation: Address – 0x00000080, Data – 0x1234ABCD, CRC Byte – 0x45 (Sample value; does not match with the actual CRC calculation)

Table 7-15. Example for 32-bit Write Operation Packet

Start Byte		Control Word 0				Control Word 1		Control Word 2	Data Bytes				CRC
Target ID	I ² C Write	OP_R/W	CRC_EN	DLEN	MEM_SEC	MEM_PAGE	MEM_ADDR	MEM_ADDR	DB0	DB1	DB2	DB3	CRC Byte
A6A0	W0	CW23	CW22	CW21-CW20	CW19-CW16	CW15-CW12	CW11-CW8	CW7-CW0	D7D0	D7D0	D7D0	D7D0	C7C0
0x01	0x0	0x0	0x1	0x1	0x0	0x0	0x0	0x80	0xCD	0xAB	0x34	0x12	0x45
0x02		0x50				0x00		0x80	0xCD	0xAB	0x34	0x12	0x45

Example for 64-bit Write Operation: Address - 0x00000080, Data Address 0x00000080 - Data 0x01234567, Data Address 0x00000082 – Data 0x89ABCDEF, CRC Byte – 0x45 (Sample value; does not match with the actual CRC calculation)

Table 7-16. Example for 64-bit Write Operation Packet

Start Byte		Control Word 0				Control Word 1			Control Word 2	Data Bytes	CRC
Target ID	I ² C Write	OP_R/W	CRC_EN	DLEN	MEM_SEC	MEM_PAGE	MEM_ADDR	MEM_ADDR	DB0 - DB7	CRC Byte	
A6A0	W0	CW23	CW22	CW21-CW20	CW19-CW16	CW15-CW12	CW11-CW8	CW7-CW0	[D7D0] x 8	C7C0	
0x01	0x0	0x0	0x1	0x2	0x0	0x0	0x0	0x80	0x67452301EFCDA89	0x45	
0x02	0x60				0x00			0x80	0x67452301EFCDA89	0x45	

Example for 32-bit Read Operation: Address – 0x00000080, Data – 0x1234ABCD, CRC Byte – 0x56 (Sample value; does not match with the actual CRC calculation)

Table 7-17. Example for 32-bit Read Operation Packet

Start Byte		Control Word 0				Control Word 1			Control Word 2	Start Byte	Byte 0	Byte 1	Byte 2	Byte 3	Byte 4
Target ID	I ² C Write	R/W	CRC_EN	DLEN	MEM_SEC	MEM_PAGE	MEM_ADDR	MEM_ADDR	Target ID	I ² C Read	DB0	DB1	DB2	DB3	CRC Byte
A6A0	W0	CW23	CW22	CW21-CW20	CW19-CW16	CW15-CW12	CW11-CW8	CW7-CW0	A6A0	W0	D7D0	D7D0	D7D0	D7D0	C7C0
0x01	0x0	0x1	0x1	0x1	0x0	0x0	0x0	0x80	0x01	0x1	0xCD	0xAB	0x34	0x12	0x56
0x02	0xD0				0x00			0x80	0x03	0xCD		0xAB	0x34	0x12	0x56

7.6.2.5 I²C Clock Stretching

The I²C peripheral in MCF8329HS implements clock stretching under certain conditions when there are pending I²C interrupts waiting to be processed. During clock stretching, MCF8329HS pulls SCL low and the I²C bus is unavailable for use by other devices. The following is a list of conditions under which clock stretching can occur:

- Start interrupt pending:** There are two scenarios when a start interrupt can result in clock stretching,
 - When target ID is a match, I²C peripheral in MCF8329HS raises a start interrupt request. Until this start interrupt request is processed, clock is stretched. Upon processing this request, clock is released and an ACK (marked in yellow or grey in [Figure 7-55](#) and [Figure 7-56](#)) is sent to the controller for continuing with the transaction.
 - If Start (followed by target ID match) for a new transaction is received when a receive interrupt from previous transaction is yet to be processed, clock is stretched until both the receive interrupt and start interrupt are processed in chronological order. This process maintains that previous transaction is executed correctly before initiating the next transaction.
- Receive interrupt pending:** When a receive interrupt is waiting to be processed and the receive register is full which occurs when two successive bytes (data or control) have been received by MCF8329HS (separated by one ACK shown as blue boxes in [Figure 7-55](#) and [Figure 7-56](#)) without the receive interrupt generated by the first byte being processed. Upon receive of second byte, clock is stretched until receive interrupt generated by the first byte is processed.
- Transmit buffer is empty:** In case of a transmit interrupt pending (to send data back to controller), if the transmit buffer is waiting to be populated with data to be read back to the controller, clock stretching is done until the transmit buffer is populated with requested data. After the buffer is populated, clock is released and data is sent to controller.

Note

I²C clock stretching is timed out after approximately 5ms by MCF8329HS to allow I²C bus access for other devices on the same bus.

7.6.2.6 CRC Byte Calculation

An 8-bit CCIT polynomial ($x^8 + x^2 + x + 1$) and CRC initial value 0xFF is used for CRC computation.

CRC Calculation in Write Operation: When the external MCU writes to MCF8329HS, if the CRC is enabled, the external MCU has to compute an 8-bit CRC byte and add the CRC byte at the end of the data. MCF8329HS computes CRC using the same polynomial internally and if there is a mismatch, the write request is discarded. Input data for CRC calculation by external MCU for write operation are listed below:

1. Target ID + write bit.
2. Control word – 3 bytes
3. Data bytes – 2/4/8 bytes

CRC Calculation in Read Operation: When the external MCU reads from MCF8329HS, if the CRC is enabled, MCF8329HS sends the CRC byte at the end of the data. The CRC computation in read operation involves the start byte, control words sent by external MCU along with data bytes sent by MCF8329HS. Input data for CRC calculation by external MCU to verify the data sent by MCF8329HS are listed below :

1. Target ID + write bit
2. Control word – 3 bytes
3. Target ID + read bit
4. Data bytes – 2/4/8 bytes

8 EEPROM (Non-Volatile) Register Map

8.1 Algorithm_Configuration Registers

Table 8-1 lists the memory-mapped registers for the Algorithm_Configuration registers. All register offset addresses not listed in Table 8-1 should be considered as reserved locations and the register contents should not be modified.

Table 8-1. ALGORITHM_CONFIGURATION Registers

Offset	Acronym	Register Name	Section
80h	ISD_CONFIG	ISD Configuration	Section 8.1.1
82h	REV_DRIVE_CONFIG	Reverse Drive Configuration	Section 8.1.2
84h	MOTOR_STARTUP1	Motor Startup Configuration1	Section 8.1.3
86h	MOTOR_STARTUP2	Motor Startup Configuration2	Section 8.1.4
88h	CLOSED_LOOP1	Close Loop Configuration1	Section 8.1.5
8Ah	CLOSED_LOOP2	Close Loop Configuration2	Section 8.1.6
8Ch	CLOSED_LOOP3	Close Loop Configuration3	Section 8.1.7
8Eh	CLOSED_LOOP4	Close Loop Configuration4	Section 8.1.8
94h	REF_PROFILES1	Reference Profile Configuration1	Section 8.1.9
96h	REF_PROFILES2	Reference Profile Configuration2	Section 8.1.10
98h	REF_PROFILES3	Reference Profile Configuration3	Section 8.1.11
9Ah	REF_PROFILES4	Reference Profile Configuration4	Section 8.1.12
9Ch	REF_PROFILES5	Reference Profile Configuration5	Section 8.1.13
9Eh	REF_PROFILES6	Reference Profile Configuration6	Section 8.1.14

Complex bit access types are encoded to fit into small table cells. Table 8-2 shows the codes that are used for access types in this section.

Table 8-2. Algorithm_Configuration Access Type Codes

Access Type	Code	Description
Read Type		
R	R	Read
Write Type		
W	W	Write
Reset or Default Value		
-n		Value after reset or the default value

8.1.1 ISD_CONFIG Register (Offset = 80h) [Reset = 0000000h]

ISD_CONFIG is shown in Figure 8-1 and described in Table 8-3.

Return to the [Summary Table](#).

Register to configure initial speed detect settings

Figure 8-1. ISD_CONFIG Register

31	30	29	28	27	26	25	24	
PARITY	ISD_EN	BRAKE_EN	HIZ_EN	RVS_DR_EN	RESYNC_EN	FW_DRV_RESYN_THR		
R-0h	R/W-0h	R/W-0h	R/W-0h	R/W-0h	R/W-0h	R/W-0h		
23	22	21	20	19	18	17	16	
FW_DRV_RESYN_THR		ISD_BEMF_FILE_ENABLE	SINGLE_SHUNT_BLANKING_TIME				BRK_TIME	

Figure 8-1. ISD_CONFIG Register (continued)

R/W-0h	R/W-0h	R/W-0h	R/W-0h
15	14	13	12
BRK_TIME		HIZ_TIME	
R/W-0h		R/W-0h	
7	6	5	4
STAT_DETECT_THR		REV_DRV_HANDOFF_THR	
R/W-0h		R/W-0h	
3	2	1	0
REV_DRV_OPEN_LOOP_CURRENT		R/W-0h	
R/W-0h		R/W-0h	

Table 8-3. ISD_CONFIG Register Field Descriptions

Bit	Field	Type	Reset	Description
31	PARITY	R	0h	Parity bit
30	ISD_EN	R/W	0h	ISD enable during MSS 0h = Disable 1h = Enable
29	BRAKE_EN	R/W	0h	Brake enable during MSS 0h = Disable 1h = Enable
28	HIZ_EN	R/W	0h	Hi-Z enable during MSS 0h = Disable 1h = Enable
27	RVS_DR_EN	R/W	0h	Reverse drive operation enable during MSS 0h = Disable 1h = Enable
26	RESYNC_EN	R/W	0h	Resynchronization enable during MSS 0h = Disable 1h = Enable
25-22	FW_DRV_RESYN_THR	R/W	0h	Minimum speed threshold for resynchronize to closed loop (% of MAX_SPEED) 0h = 5% 1h = 10% 2h = 15% 3h = 20% 4h = 25% 5h = 30% 6h = 35% 7h = 40% 8h = 45% 9h = 50% Ah = Not Applicable Bh = Not Applicable Ch = Not Applicable Dh = Not Applicable Eh = Not Applicable Fh = Not Applicable
21	ISD_BEMF_FILT_ENABLER	R/W	0h	BEMF filter enable during ISD 0h = Disable 1h = Enable

Table 8-3. ISD_CONFIG Register Field Descriptions (continued)

Bit	Field	Type	Reset	Description
20-17	SINGLE_SHUNT_BLANKING_TIME	R/W	0h	Blanking time before current sampling from the PWM edge 0h = 0.25µs 1h = 0.5µs 2h = 0.75µs 3h = 1µs 4h = 1.25µs 5h = 1.5µs 6h = 1.75µs 7h = 2µs 8h = 2.25µs 9h = 2.5µs Ah = 2.75µs Bh = 3µs Ch = 3.5µs Dh = 4µs Eh = 5µs Fh = 6µs
16-13	BRK_TIME	R/W	0h	Brake time during MSS 0h = 10ms 1h = 50ms 2h = 100ms 3h = 200ms 4h = 300ms 5h = 400ms 6h = 500ms 7h = 750ms 8h = 1s 9h = 2s Ah = 3s Bh = 4s Ch = 5s Dh = 7.5s Eh = 10s Fh = 15s
12-9	HIZ_TIME	R/W	0h	Hi-Z time during MSS 0h = 10ms 1h = 50ms 2h = 100ms 3h = 200ms 4h = 300ms 5h = 400ms 6h = 500ms 7h = 750ms 8h = 1s 9h = 2s Ah = 3s Bh = 4s Ch = 5s Dh = 7.5s Eh = 10s Fh = 15s
8-6	STAT_DETECT_THR	R/W	0h	BEMF threshold to detect if motor is stationary 0h = 100mV 1h = 150mV 2h = 200mV 3h = 500mV 4h = 1000mV 5h = 1500mV 6h = 2000mV 7h = 3000mV

Table 8-3. ISD_CONFIG Register Field Descriptions (continued)

Bit	Field	Type	Reset	Description
5-3	REV_DRV_HANDOFF_THR	R/W	0h	Speed threshold for transitioning to open-loop during reverse drive (% of MAX_SPEED) 0h = 5% 1h = 10% 2h = 15% 3h = 20% 4h = 25% 5h = 30% 6h = 40% 7h = 50%
2-0	REV_DRV_OPEN_LOOP_CURRENT	R/W	0h	Open loop current limit during reverse drive (% of BASE_CURRENT) 0h = 5% 1h = 10% 2h = 15% 3h = 20% 4h = 25% 5h = 30% 6h = 40% 7h = 50%

8.1.2 REV_DRIVE_CONFIG Register (Offset = 82h) [Reset = 0000000h]

REV_DRIVE_CONFIG is shown in [Figure 8-2](#) and described in [Table 8-4](#).

Return to the [Summary Table](#).

Register to configure reverse drive settings

Figure 8-2. REV_DRIVE_CONFIG Register

31	30	29	28	27	26	25	24
PARITY	REV_DRV_OPEN_LOOP_ACCEL_A1				BUS_CURRENT_LIMIT_EN_MIN_VOLTAGE		
R-0h	R/W-0h				R/W-0h		
23	22	21	20	19	18	17	16
BUS_CURRENT_LIMIT_EN_MIN_VOLTAGE	ACTIVE_BRAKE_CURRENT_LIMIT			ACTIVE_BRAKE_KP			
R/W-0h	R/W-0h			R/W-0h			
15	14	13	12	11	10	9	8
ACTIVE_BRAKE_KP						ACTIVE_BRAKE_KI	
R/W-0h						R/W-0h	
7	6	5	4	3	2	1	0
ACTIVE_BRAKE_KI							
R/W-0h							

Table 8-4. REV_DRIVE_CONFIG Register Field Descriptions

Bit	Field	Type	Reset	Description
31	PARITY	R	0h	Parity bit

Table 8-4. REV_DRIVE_CONFIG Register Field Descriptions (continued)

Bit	Field	Type	Reset	Description
30-27	REV_DRV_OPEN_LOOP_ACCEL_A1	R/W	0h	Open loop acceleration coefficient A1 during reverse drive 0h = 0.1Hz/s 1h = 0.5Hz/s 2h = 1Hz/s 3h = 2.5Hz/s 4h = 5Hz/s 5h = 10Hz/s 6h = 25Hz/s 7h = 50Hz/s 8h = 75Hz/s 9h = 100Hz/s Ah = 250Hz/s Bh = 500Hz/s Ch = 750Hz/s Dh = 1000Hz/s Eh = 5000Hz/s Fh = 10000Hz/s
26-23	BUS_CURRENT_LIMIT_EN_MIN_VOLTAGE	R/W	0h	Minimum PVDD voltage below which bus current limit is enabled (Applicable only if CTRL_MODE = 1h or BUS_POWER_LIMIT_ENABLE = 1) 0h = Bus current Limit is disabled 1h = 9V 2h = 10V 3h = 11V 4h = 12V 5h = 18V 6h = 20V 7h = 22V 8h = 24V 9h = 30V Ah = 32V Bh = 34V Ch = 36V Dh = 40V Eh = 44V Fh = 48V
22-20	ACTIVE_BRAKE_CURRENT_LIMIT	R/W	0h	Bus current limit during active braking (% of BASE_CURRENT) 0h = 10% 1h = 20% 2h = 30% 3h = 40% 4h = 50% 5h = 60% 6h = 70% 7h = 80%
19-10	ACTIVE_BRAKE_KP	R/W	0h	10-bit value for active braking PI loop Kp. $K_p = \text{ACTIVE_BRAKE_KP} / 2^7$
9-0	ACTIVE_BRAKE_KI	R/W	0h	10-bit value for active braking PI loop Ki. $K_i = \text{ACTIVE_BRAKE_KI} / 2^9$

8.1.3 MOTOR_STARTUP1 Register (Offset = 84h) [Reset = 0000000h]

MOTOR_STARTUP1 is shown in [Figure 8-3](#) and described in [Table 8-5](#).

Return to the [Summary Table](#).

Register to configure motor startup settings1

Figure 8-3. MOTOR_STARTUP1 Register

31	30	29	28	27	26	25	24
PARITY	MTR_STARTUP		ALIGN_SLOW_RAMP_RATE			ALIGN_TIME	

Table 8-5. MOTOR_STARTUP1 Register Field Descriptions (continued)

Bit	Field	Type	Reset	Description
20-17	ALIGN_OR_SLOW_CURRENT_ILIMIT	R/W	0h	Align or slow first cycle current limit (% of BASE_CURRENT) 0h = 5% 1h = 10% 2h = 15% 3h = 20% 4h = 25% 5h = 30% 6h = 40% 7h = 45% 8h = 50% 9h = 55% Ah = 60% Bh = 65% Ch = 70% Dh = 75% Eh = 80% Fh = 85%
16-14	RESERVED	R	0h	Reserved
13-10	IPD_CURR_THR	R/W	0h	IPD current threshold (% of BASE_CURRENT) 0h = Not Applicable 1h = Not Applicable 2h = Not Applicable 3h = 20% 4h = 26.7% 5h = 33.3% 6h = 40% 7h = 46.7% 8h = 53.3% 9h = 60% Ah = 66.7% Bh = 73.3% Ch = 80% Dh = 86.7% Eh = 93.3% Fh = 100%
9-8	RESERVED	R	0h	Reserved
7-6	IPD_ADV_ANGLE	R/W	0h	IPD advance angle 0h = 0° 1h = 30° 2h = 60° 3h = 90°
5-4	IPD_REPEAT	R/W	0h	Number of times IPD is executed 0h = 1 time 1h = average of 2 times 2h = average of 3 times 3h = average of 4 times
3	RESERVED	R	0h	Reserved
2	IQ_RAMP_DOWN_EN	R/W	0h	Q-axis current ramp-down enable during open-loop to closed-loop transition 0h = Disable 1h = Enable
1	ACTIVE_BRAKE_EN	R/W	0h	Active braking enable during deceleration 0h = Disable 1h = Enable
0	RESERVED	R	0h	Reserved

8.1.4 MOTOR_STARTUP2 Register (Offset = 86h) [Reset = 0000000h]

MOTOR_STARTUP2 is shown in [Figure 8-4](#) and described in [Table 8-6](#).

Return to the [Summary Table](#).

Register to configure motor startup settings2

Figure 8-4. MOTOR_STARTUP2 Register

31	30	29	28	27	26	25	24
PARITY	OL_ILIMIT			OL_ACC_A1			
R-0h	R/W-0h			R/W-0h			
23	22	21	20	19	18	17	16
OL_ACC_A1	OL_ACC_A2			AUTO_HANDOFF_FF_EN	OPN_CL_HANDOFF_THR		
R/W-0h	R/W-0h			R/W-0h	R/W-0h		
15	14	13	12	11	10	9	8
OPN_CL_HANDOFF_THR			STANDBY_POWER		AUTO_HANDOFF_MIN_BEMF		
R/W-0h			R/W-0h		R/W-0h		
7	6	5	4	3	2	1	0
SLOW_FIRST_CYC_FREQ				RESERVED	THETA_ERROR_RAMP_RATE		
R/W-0h				R-0h	R/W-0h		

Table 8-6. MOTOR_STARTUP2 Register Field Descriptions

Bit	Field	Type	Reset	Description
31	PARITY	R	0h	Parity bit
30-27	OL_ILIMIT	R/W	0h	Open-loop current limit (% of BASE_CURRENT) 0h = 5% 1h = 10% 2h = 15% 3h = 20% 4h = 25% 5h = 30% 6h = 40% 7h = 45% 8h = 50% 9h = 55% Ah = 60% Bh = 65% Ch = 70% Dh = 75% Eh = 80% Fh = 85%
26-23	OL_ACC_A1	R/W	0h	Open loop acceleration coefficient A1 0h = 0.1Hz/s 1h = 0.5Hz/s 2h = 1Hz/s 3h = 2.5Hz/s 4h = 5Hz/s 5h = 10Hz/s 6h = 25Hz/s 7h = 50Hz/s 8h = 75Hz/s 9h = 100Hz/s Ah = 250Hz/s Bh = 500Hz/s Ch = 750Hz/s Dh = 1000Hz/s Eh = 5000Hz/s Fh = 10000Hz/s

Table 8-6. MOTOR_STARTUP2 Register Field Descriptions (continued)

Bit	Field	Type	Reset	Description
22-19	OL_ACC_A2	R/W	0h	Open loop acceleration coefficient A2 0h = 0Hz/s ² 1h = 0.5Hz/s ² 2h = 1Hz/s ² 3h = 2.5Hz/s ² 4h = 5Hz/s ² 5h = 10Hz/s ² 6h = 25Hz/s ² 7h = 50Hz/s ² 8h = 75Hz/s ² 9h = 100Hz/s ² Ah = 250Hz/s ² Bh = 500Hz/s ² Ch = 750Hz/s ² Dh = 1000Hz/s ² Eh = 5000Hz/s ² Fh = 10000Hz/s ²
18	AUTO_HANDOFF_EN	R/W	0h	Auto handoff enable for open loop to closed loop transition 0h = Disable 1h = Enable
17-13	OPN_CL_HANDOFF_THR	R/W	0h	Open-loop to closed-loop handoff threshold (% of MAX_SPEED) 0h = 1% 1h = 2% 2h = 3% 3h = 4% 4h = 5% 5h = 6% 6h = 7% 7h = 8% 8h = 9% 9h = 10% Ah = 11% Bh = 12% Ch = 13% Dh = 14% Eh = 15% Fh = 16% 10h = 17% 11h = 18% 12h = 19% 13h = 20% 14h = 22.5% 15h = 25% 16h = 27.5% 17h = 30% 18h = 32.5% 19h = 35% 1Ah = 37.5% 1Bh = 40% 1Ch = 42.5% 1Dh = 45% 1Eh = 47.5% 1Fh = 50%
12-11	STANDBY_POWER	R/W	0h	Standby board power consumption (when motor is not driven) 0h = 0.5W 1h = 1W 2h = 2W 3h = 4W

Table 8-6. MOTOR_STARTUP2 Register Field Descriptions (continued)

Bit	Field	Type	Reset	Description
10-8	AUTO_HANDOFF_MIN_BEMF	R/W	0h	Minimum BEMF threshold required for auto handoff 0h = 0mV 1h = 100mV 2h = 200mV 3h = 500mV 4h = 1000mV 5h = 2000mV 6h = 2500mV 7h = 3000mV
7-4	SLOW_FIRST_CYC_FREQ	R/W	0h	First cycle frequency in slow first cycle startup (% of MAX_SPEED) 0h = 0.1% 1h = 0.3% 2h = 0.5% 3h = 0.7% 4h = 1% 5h = 1.5% 6h = 2% 7h = 2.5% 8h = 3% 9h = 4% Ah = 5% Bh = 7.5% Ch = 10% Dh = 15% Eh = 20% Fh = 25%
3	RESERVED	R	0h	Reserved
2-0	THETA_ERROR_RAMP_RATE	R/W	0h	Ramp rate for reducing difference between estimated angle and open loop angle during open loop to closed loop transition 0h = 0.01deg/ms 1h = 0.05deg/ms 2h = 0.1deg/ms 3h = 0.2deg/ms 4h = 0.5deg/ms 5h = 1deg/ms 6h = 2deg/ms 7h = 4deg/ms

8.1.5 CLOSED_LOOP1 Register (Offset = 88h) [Reset = 0000000h]

CLOSED_LOOP1 is shown in [Figure 8-5](#) and described in [Table 8-7](#).

Return to the [Summary Table](#).

Register to configure close loop settings1

Figure 8-5. CLOSED_LOOP1 Register

31	30	29	28	27	26	25	24
PARITY	OVERMODULATION_ENABLE	CL_ACC				RESERVED	
R-0h	R/W-0h	R/W-0h				R-0h	
23	22	21	20	19	18	17	16
CL_DEC				PWM_FREQ_OUT			
R/W-0h				R/W-0h			
15	14	13	12	11	10	9	8
PWM_FREQ_OUT	ESTIMATOR_FILTER_EN	FG_SEL		FG_DIV			
R/W-0h	R/W-0h	R/W-0h		R/W-0h			

Figure 8-5. CLOSED_LOOP1 Register (continued)

7	6	5	4	3	2	1	0
FG_CONFIG	FG_BEMF_THR		AVS_EN	RESERVED	RESERVED	RESERVED	RESERVED
R/W-0h	R/W-0h		R/W-0h	R-0h	R-0h	R-0h	R-0h

Table 8-7. CLOSED_LOOP1 Register Field Descriptions

Bit	Field	Type	Reset	Description
31	PARITY	R	0h	Parity bit
30	OVERMODULATION_ENABLE	R/W	0h	Over-modulation enable 0h = Disable 1h = Enable
29-25	CL_ACC	R/W	0h	Closed loop acceleration Speed control (Hz/s) Power control (W/s) Current control (0.1A/s) Modulation index control(0.01% modulation index/s) 0h = 0.5 1h = 1 2h = 2.5 3h = 5 4h = 7.5 5h = 10 6h = 20 7h = 40 8h = 60 9h = 80 Ah = 100 Bh = 200 Ch = 300 Dh = 400 Eh = 500 Fh = 600 10h = 700 11h = 800 12h = 1000 13h = 1250 14h = 1500 15h = 2000 16h = 2500 17h = 3000 18h = 4000 19h = 5000 1Ah = 6000 1Bh = 8000 1Ch = 10000 1Dh = 20000 1Eh = 40000 1Fh = No limit
24	RESERVED	R	0h	Reserved

Table 8-7. CLOSED_LOOP1 Register Field Descriptions (continued)

Bit	Field	Type	Reset	Description
23-19	CL_DEC	R/W	0h	Closed loop deceleration Speed control (Hz/s) Power control (W/s) Current control (0.1A/s) Modulation index control(0.01% modulation index/s) 0h = 0.5 1h = 1 2h = 2.5 3h = 5 4h = 7.5 5h = 10 6h = 20 7h = 40 8h = 60 9h = 80 Ah = 100 Bh = 200 Ch = 300 Dh = 400 Eh = 500 Fh = 600 10h = 700 11h = 800 12h = 1000 13h = 1250 14h = 1500 15h = 2000 16h = 2500 17h = 3000 18h = 4000 19h = 5000 1Ah = 6000 1Bh = 8000 1Ch = 10000 1Dh = 20000 1Eh = 40000 1Fh = No limit
18-15	PWM_FREQ_OUT	R/W	0h	PWM output frequency 0h = 10kHz 1h = 15kHz 2h = 20kHz 3h = 25kHz 4h = 30kHz 5h = 35kHz 6h = 40kHz 7h = 45kHz 8h = 50kHz 9h = 55kHz Ah = 60kHz Bh = 65kHz Ch = 70kHz Dh = 75kHz Eh = 80kHz Fh = Not Applicable
14	ESTIMATOR_FILT_EN	R/W	0h	Estimator filter enable (Note: May introduce control response delay) 0h = Disable 1h = Enable
13-12	FG_SEL	R/W	0h	Configure motor states when speed feedback is available on FG 0h = Output FG in ISD, open loop and closed loop 1h = Output FG in only closed loop 2h = Output FG in open loop for the first try 3h = Not Defined

Table 8-7. CLOSED_LOOP1 Register Field Descriptions (continued)

Bit	Field	Type	Reset	Description
11-8	FG_DIV	R/W	0h	FG division factor 0h = Commutation cycle, 3x of electrical 1h = Divide by 1 (2-pole motor mechanical speed) 2h = Divide by 2 (4-pole motor mechanical speed) 3h = Divide by 3 (6-pole motor mechanical speed) 4h = Divide by 4 (8-pole motor mechanical speed) 5h = Divide by 5 (10-pole motor mechanical speed) 6h = Divide by 6 (12-pole motor mechanical speed) 7h = Divide by 7 (14-pole motor mechanical speed) 8h = Divide by 8 (16-pole motor mechanical speed) 9h = Divide by 9 (18-pole motor mechanical speed) Ah = Divide by 10 (20-pole motor mechanical speed) Bh = Divide by 11 (22-pole motor mechanical speed) Ch = Divide by 12 (24-pole motor mechanical speed) Dh = Divide by 13 (26-pole motor mechanical speed) Eh = Divide by 14 (28-pole motor mechanical speed) Fh = Divide by 15 (30-pole motor mechanical speed)
7	FG_CONFIG	R/W	0h	FG output configuration 0h = FG active as long as motor is driven 1h = FG active till BEMF drops below BEMF threshold defined by FG_BEMF_THR
6-4	FG_BEMF_THR	R/W	0h	BEMF threshold above which speed feedback information is available on FG, calculated as voltage at SHx pin divided by voltage gain(refer BUS_VOLT). 0h = ±1mV 1h = ±2mV 2h = ±5mV 3h = ±10mV 4h = ±20mV 5h = ±30mV 6h = Not Applicable 7h = Not Applicable
3	AVS_EN	R/W	0h	AVS enable 0h = Disable 1h = Enable
2	RESERVED	R	0h	Reserved
1	RESERVED	R	0h	Reserved
0	RESERVED	R	0h	Reserved

8.1.6 CLOSED_LOOP2 Register (Offset = 8Ah) [Reset = 0000000h]

CLOSED_LOOP2 is shown in [Figure 8-6](#) and described in [Table 8-8](#).

Return to the [Summary Table](#).

Register to configure close loop settings2

Figure 8-6. CLOSED_LOOP2 Register

31	30	29	28	27	26	25	24
PARITY	RESERVED	MTR_STOP		MTR_STOP_BRK_TIME			
R-0h	R-0h	R/W-0h		R/W-0h			
23	22	21	20	19	18	17	16
ACT_SPIN_THR				BRAKE_SPEED_THRESHOLD			
R/W-0h				R/W-0h			
15	14	13	12	11	10	9	8
MOTOR_RES							
R/W-0h							

Figure 8-6. CLOSED_LOOP2 Register (continued)

7	6	5	4	3	2	1	0
MOTOR_IND							
R/W-0h							

Table 8-8. CLOSED_LOOP2 Register Field Descriptions

Bit	Field	Type	Reset	Description
31	PARITY	R	0h	Parity bit
30	RESERVED	R	0h	Reserved
29-28	MTR_STOP	R/W	0h	Motor stop mode 0h = Hi-Z 1h = Low side braking 2h = Active spin down 3h = Reserved
27-24	MTR_STOP_BRK_TIME	R/W	0h	Brake time during motor stop 0h = 10ms 1h = 50ms 2h = 100ms 3h = 200ms 4h = 300ms 5h = 400ms 6h = 500ms 7h = 750ms 8h = 1s 9h = 2s Ah = 3s Bh = 4s Ch = 5s Dh = 7.5s Eh = 10s Fh = 15s
23-20	ACT_SPIN_THR	R/W	0h	Active spin-down speed threshold (% of MAX_SPEED) 0h = 100% 1h = 90% 2h = 80% 3h = 70% 4h = 60% 5h = 50% 6h = 45% 7h = 40% 8h = 35% 9h = 30% Ah = 25% Bh = 20% Ch = 15% Dh = 10% Eh = Not Applicable Fh = Not Applicable

Table 8-8. CLOSED_LOOP2 Register Field Descriptions (continued)

Bit	Field	Type	Reset	Description
19-16	BRAKE_SPEED_THRES HOLD	R/W	0h	Speed threshold below which brake is applied for BRAKE pin and Motor stop mode (Low side Braking) (% of MAX_SPEED) 0h = 100% 1h = 90% 2h = 80% 3h = 70% 4h = 60% 5h = 50% 6h = 45% 7h = 40% 8h = 35% 9h = 30% Ah = 25% Bh = 20% Ch = 15% Dh = 10% Eh = Not Applicable Fh = Not Applicable
15-8	MOTOR_RES	R/W	0h	Motor phase resistance
7-0	MOTOR_IND	R/W	0h	Motor phase inductance

8.1.7 CLOSED_LOOP3 Register (Offset = 8Ch) [Reset = 0000000h]

CLOSED_LOOP3 is shown in [Figure 8-7](#) and described in [Table 8-9](#).

Return to the [Summary Table](#).

Register to configure close loop settings3

Figure 8-7. CLOSED_LOOP3 Register

31	30	29	28	27	26	25	24
PARITY		MOTOR_BEMF_CONST					
R-0h		R/W-0h					
23	22	21	20	19	18	17	16
MOTOR_BEMF_CONST		CURR_LOOP_KP					
R/W-0h		R/W-0h					
15	14	13	12	11	10	9	8
CURR_LOOP_KP			CURR_LOOP_KI				
R/W-0h			R/W-0h				
7	6	5	4	3	2	1	0
CURR_LOOP_KI				SPD_LOOP_KP			
R/W-0h				R/W-0h			

Table 8-9. CLOSED_LOOP3 Register Field Descriptions

Bit	Field	Type	Reset	Description
31	PARITY	R	0h	Parity bit
30-23	MOTOR_BEMF_CONST	R/W	0h	Motor BEMF constant
22-13	CURR_LOOP_KP	R/W	0h	10-bit Kp value for Q-axis and D-axis current PI loop. CURR_LOOP_KP is divided in 2 sections - SCALE(9:8) and VALUE(7:0). Kp = VALUE / 10^SCALE Set to 0 for auto calculation of current Kp and Ki

Table 8-9. CLOSED_LOOP3 Register Field Descriptions (continued)

Bit	Field	Type	Reset	Description
12-3	CURR_LOOP_KI	R/W	0h	10-bit Ki value for Q-axis and D-axis current PI loop. CURR_LOOP_KI is divided in 2 sections - SCALE(9:8) and VALUE(7:0). $K_i = 1000 \times \text{VALUE} / 10^{\text{SCALE}}$ Set to 0 for auto calculation of current Kp and Ki
2-0	SPD_LOOP_KP	R/W	0h	3MSB bits for speed loop/power loop Kp. SPD_LOOP_KP is divided in 2 sections - SCALE(9:8) and VALUE(7:0). $K_p = 0.01 \times \text{VALUE} / 10^{\text{SCALE}}$.

8.1.8 CLOSED_LOOP4 Register (Offset = 8Eh) [Reset = 0000000h]

CLOSED_LOOP4 is shown in [Figure 8-8](#) and described in [Table 8-10](#).

Return to the [Summary Table](#).

Register to configure close loop settings4

Figure 8-8. CLOSED_LOOP4 Register

31	30	29	28	27	26	25	24
PARITY		SPD_LOOP_KP					
R-0h		R/W-0h					
23	22	21	20	19	18	17	16
SPD_LOOP_KI							
R/W-0h							
15	14	13	12	11	10	9	8
SPD_LOOP_KI		MAX_SPEED					
R/W-0h		R/W-0h					
7	6	5	4	3	2	1	0
MAX_SPEED							
R/W-0h							

Table 8-10. CLOSED_LOOP4 Register Field Descriptions

Bit	Field	Type	Reset	Description
31	PARITY	R	0h	Parity bit
30-24	SPD_LOOP_KP	R/W	0h	7LSB bits for speed loop/power loop Kp. SPD_LOOP_KP is divided in 2 sections - SCALE(10:9) and VALUE(8:0). $K_p = 0.01 \times \text{VALUE} / 10^{\text{SCALE}}$.
23-14	SPD_LOOP_KI	R/W	0h	10 bit value for speed loop/power loop Ki. SPD_LOOP_KI is divided in 2 sections - SCALE(9:8) and VALUE(7:0). $K_i = 0.1 \times \text{VALUE} / 10^{\text{SCALE}}$.
13-0	MAX_SPEED	R/W	0h	Maximum motor speed in electrical Hz = MAX_SPEED/4 For example, if MAX_SPEED is 0x7D0(2000d), then maximum motor speed (Hz) is 2000/4 = 500Hz

8.1.9 REF_PROFILES1 Register (Offset = 94h) [Reset = 0000000h]

REF_PROFILES1 is shown in [Figure 8-9](#) and described in [Table 8-11](#).

Return to the [Summary Table](#).

Register to configure reference profile1

Figure 8-9. REF_PROFILES1 Register

31	30	29	28	27	26	25	24
PARITY	REF_PROFILE_CONFIG			DUTY_ON1			
R-0h	R/W-0h			R/W-0h			
23	22	21	20	19	18	17	16
DUTY_ON1			DUTY_OFF1				
R/W-0h			R/W-0h				
15	14	13	12	11	10	9	8
DUTY_OFF1			DUTY_CLAMP1				
R/W-0h			R/W-0h				
7	6	5	4	3	2	1	0
DUTY_CLAMP1			DUTY_A				
R/W-0h			R/W-0h				

Table 8-11. REF_PROFILES1 Register Field Descriptions

Bit	Field	Type	Reset	Description
31	PARITY	R	0h	Parity bit
30-29	REF_PROFILE_CONFIG	R/W	0h	Reference profile mode configuration 0h = Reference mode 1h = Linear mode 2h = Staircase mode 3h = Forward Reverse mode
28-21	DUTY_ON1	R/W	0h	Duty_ON1 Configuration Turn On duty cycle (%) = $\{(DUTY_ON1/256) \times 100\}$
20-13	DUTY_OFF1	R/W	0h	Duty_OFF1 Configuration Turn Off duty cycle (%) = $\{(DUTY_OFF1/256) \times 100\}$
12-5	DUTY_CLAMP1	R/W	0h	Duty_CLAMP1 Configuration duty cycle for clamping (%) = $\{(DUTY_CLAMP1/256) \times 100\}$
4-0	DUTY_A	R/W	0h	5MSB bits for Duty Cycle A

8.1.10 REF_PROFILES2 Register (Offset = 96h) [Reset = 0000000h]

REF_PROFILES2 is shown in [Figure 8-10](#) and described in [Table 8-12](#).

Return to the [Summary Table](#).

Register to configure reference profile2

Figure 8-10. REF_PROFILES2 Register

31	30	29	28	27	26	25	24
PARITY	DUTY_A			DUTY_B			
R-0h	R/W-0h			R/W-0h			
23	22	21	20	19	18	17	16
DUTY_B			DUTY_C				
R/W-0h			R/W-0h				
15	14	13	12	11	10	9	8
DUTY_C			DUTY_D				
R/W-0h			R/W-0h				

Figure 8-10. REF_PROFILES2 Register (continued)

7	6	5	4	3	2	1	0
DUTY_D				DUTY_E			
R/W-0h				R/W-0h			

Table 8-12. REF_PROFILES2 Register Field Descriptions

Bit	Field	Type	Reset	Description
31	PARITY	R	0h	Parity bit
30-28	DUTY_A	R/W	0h	3LSB bits for Duty Cycle A Configuration Duty Cycle A (%) = $\{(DUTY_A/256) \times 100\}$
27-20	DUTY_B	R/W	0h	Duty_B Configuration Duty cycle B (%) = $\{(DUTY_B/256) \times 100\}$
19-12	DUTY_C	R/W	0h	Duty_C Configuration Duty cycle C (%) = $\{(DUTY_C/256) \times 100\}$
11-4	DUTY_D	R/W	0h	Duty_D Configuration Duty cycle D (%) = $\{(DUTY_D/256) \times 100\}$
3-0	DUTY_E	R/W	0h	4MSB bits for Duty Cycle E

8.1.11 REF_PROFILES3 Register (Offset = 98h) [Reset = 0000000h]

REF_PROFILES3 is shown in [Figure 8-11](#) and described in [Table 8-13](#).

Return to the [Summary Table](#).

Register to configure reference profile3

Figure 8-11. REF_PROFILES3 Register

31	30	29	28	27	26	25	24
PARITY		DUTY_E			DUTY_ON2		
R-0h		R/W-0h			R/W-0h		
23	22	21	20	19	18	17	16
DUTY_ON2				DUTY_OFF2			
R/W-0h				R/W-0h			
15	14	13	12	11	10	9	8
DUTY_OFF2				DUTY_CLAMP2			
R/W-0h				R/W-0h			
7	6	5	4	3	2	1	0
DUTY_CLAMP2				DUTY_HYS		RESERVED	
R/W-0h				R/W-0h		R-0h	

Table 8-13. REF_PROFILES3 Register Field Descriptions

Bit	Field	Type	Reset	Description
31	PARITY	R	0h	Parity bit
30-27	DUTY_E	R/W	0h	4LSB bits for Duty Cycle E Configuration Duty cycle E (%) = $\{(DUTY_E/256) \times 100\}$
26-19	DUTY_ON2	R/W	0h	Duty_ON2 Configuration Turn On duty cycle (%) = $\{(DUTY_ON2/256) \times 100\}$
18-11	DUTY_OFF2	R/W	0h	Duty_OFF2 Configuration Turn Off duty cycle (%) = $\{(DUTY_OFF2/256) \times 100\}$
10-3	DUTY_CLAMP2	R/W	0h	Duty_CLAMP2 Configuration Duty cycle for clamping (%) = $\{(DUTY_CLAMP2/256) \times 100\}$

Table 8-13. REF_PROFILES3 Register Field Descriptions (continued)

Bit	Field	Type	Reset	Description
2-1	DUTY_HYS	R/W	0h	Input duty hysteresis 0h = 0% 1h = 1% 2h = 2% 3h = 3%
0	RESERVED	R	0h	Reserved

8.1.12 REF_PROFILES4 Register (Offset = 9Ah) [Reset = 0000000h]

REF_PROFILES4 is shown in [Figure 8-12](#) and described in [Table 8-14](#).

Return to the [Summary Table](#).

Register to configure reference profile4

Figure 8-12. REF_PROFILES4 Register

31	30	29	28	27	26	25	24
PARITY	REF_OFF1						
R-0h	R/W-0h						
23	22	21	20	19	18	17	16
REF_OFF1	REF_CLAMP1						
R/W-0h	R/W-0h						
15	14	13	12	11	10	9	8
REF_CLAMP1	REF_A						
R/W-0h	R/W-0h						
7	6	5	4	3	2	1	0
REF_A	REF_B						
R/W-0h	R/W-0h						

Table 8-14. REF_PROFILES4 Register Field Descriptions

Bit	Field	Type	Reset	Description
31	PARITY	R	0h	Parity bit
30-23	REF_OFF1	R/W	0h	Turn off ref Configuration Turn off reference (% of Maximum Reference) = $\{(REF_OFF1/256) \times 100\}$
22-15	REF_CLAMP1	R/W	0h	Ref Clamp1 Configuration Clamp ref (% of Maximum Reference) = $\{(REF_CLAMP1/256) \times 100\}$
14-7	REF_A	R/W	0h	Ref A configuration Ref A (% of Maximum Reference) = $\{(REF_A/256) \times 100\}$
6-0	REF_B	R/W	0h	7MSB of REF_B configuration

8.1.13 REF_PROFILES5 Register (Offset = 9Ch) [Reset = 0000000h]

REF_PROFILES5 is shown in [Figure 8-13](#) and described in [Table 8-15](#).

Return to the [Summary Table](#).

Register to configure reference profile5

Figure 8-13. REF_PROFILES5 Register

31	30	29	28	27	26	25	24
----	----	----	----	----	----	----	----

Figure 8-13. REF_PROFILES5 Register (continued)

PARITY	REF_B	REF_C					
R-0h	R/W-0h	R/W-0h					
23	22	21	20	19	18	17	16
REF_C		REF_D					
R/W-0h		R/W-0h					
15	14	13	12	11	10	9	8
REF_D		REF_E					
R/W-0h		R/W-0h					
7	6	5	4	3	2	1	0
REF_E		MIN_DUTY		MIXED_MODE_CONFIG		DUTY_COMMAND_FILTER	RESERVED
R/W-0h		R/W-0h		R/W-0h		R/W-0h	R-0h

Table 8-15. REF_PROFILES5 Register Field Descriptions

Bit	Field	Type	Reset	Description
31	PARITY	R	0h	Parity bit
30	REF_B	R/W	0h	1LSB of REF_B configuration Ref B (% of Maximum Reference) = $\{(REF_B/256) \times 100\}$
29-22	REF_C	R/W	0h	Ref C configuration Ref C (% of Maximum Reference) = $\{(REF_C/256) \times 100\}$
21-14	REF_D	R/W	0h	Ref D configuration Ref D (% of Maximum Reference) = $\{(REF_D/256) \times 100\}$
13-6	REF_E	R/W	0h	Ref E Configuration Ref E (% of Maximum Reference) = $\{(REF_E/256) \times 100\}$
5-4	MIN_DUTY	R/W	0h	Minimum input duty threshold above which motor start (Applicable only if REF_PROFILE_CONFIG = 0h) 0h = 1% 1h = 3% 2h = 5% 3h = 10%
3-2	MIXED_MODE_CONFIG	R/W	0h	Mixed control mode configuration (Applicable only if REF_PROFILE_CONFIG = 1h or REF_PROFILE_CONFIG = 2h) 0h = User defined reference modes throughout the input duty range 1h = Modulation index control if input duty > DUTY_C + DUTY_HYST; configured CTRL_MODE if input duty < DUTY_C - DUTY_HYST 2h = configured CTRL_MODE if input duty > DUTY_C + DUTY_HYST; Modulation index control if input duty < DUTY_C - DUTY_HYST 3h = Not Applicable
1	DUTY_COMMAND_FILTER	R/W	0h	Input duty filter 0h = Filter on input duty is disabled 1h = Filter on input duty is enabled (0.4%)
0	RESERVED	R	0h	Reserved

8.1.14 REF_PROFILES6 Register (Offset = 9Eh) [Reset = 0000000h]

REF_PROFILES6 is shown in [Figure 8-14](#) and described in [Table 8-16](#).

Return to the [Summary Table](#).

Register to configure reference profile6

Figure 8-14. REF_PROFILES6 Register

31	30	29	28	27	26	25	24
PARITY	REF_OFF2						
R-0h R/W-0h							
23	22	21	20	19	18	17	16
REF_OFF2	REF_CLAMP2						
R/W-0h R/W-0h							
15	14	13	12	11	10	9	8
REF_CLAMP2	HALL_ANGLE_REF						RESERVED
R/W-0h R/W-0h R-0h							
7	6	5	4	3	2	1	0
RESERVED							
R-0h							

Table 8-16. REF_PROFILES6 Register Field Descriptions

Bit	Field	Type	Reset	Description
31	PARITY	R	0h	Parity bit
30-23	REF_OFF2	R/W	0h	Turn off Ref Configuration Turn off Ref (% of Maximum Reference) = $\{(REF_OFF2/256) \times 100\}$
22-15	REF_CLAMP2	R/W	0h	Clamp Ref Configuration Clamp Ref (% of Maximum Reference) = $\{(REF_CLAMP2/256) \times 100\}$
14-9	HALL_ANGLE_REF	R/W	0h	Hall sensor angle reference for offset calibration (degrees = $HALL_ANGLE_REF \times 360/63$)
8-0	RESERVED	R	0h	Reserved

8.2 Fault_Configuration Registers

Table 8-17 lists the memory-mapped registers for the Fault_Configuration registers. All register offset addresses not listed in Table 8-17 should be considered as reserved locations and the register contents should not be modified.

Table 8-17. FAULT_CONFIGURATION Registers

Offset	Acronym	Register Name	Section
90h	FAULT_CONFIG1	Fault Configuration1	Section 8.2.1
92h	FAULT_CONFIG2	Fault Configuration2	Section 8.2.2

Complex bit access types are encoded to fit into small table cells. Table 8-18 shows the codes that are used for access types in this section.

Table 8-18. Fault_Configuration Access Type Codes

Access Type	Code	Description
Read Type		
R	R	Read
Write Type		
W	W	Write
Reset or Default Value		
-n		Value after reset or the default value

8.2.1 FAULT_CONFIG1 Register (Offset = 90h) [Reset = 0000000h]

FAULT_CONFIG1 is shown in Figure 8-15 and described in Table 8-19.

Return to the [Summary Table](#).

Register to configure fault settings1

Figure 8-15. FAULT_CONFIG1 Register

31	30	29	28	27	26	25	24
PARITY	ILIMIT			HW_LOCK_ILIMIT			
R-0h	R/W-0h			R/W-0h			
23	22	21	20	19	18	17	16
HW_LOCK_ILIMIT	LOCK_ILIMIT			EFP_FAULT_MODE	LOCK_ILIMIT_MODE		
R/W-0h	R/W-0h			R/W-0h	R/W-0h		
15	14	13	12	11	10	9	8
LOCK_ILIMIT_MODE	LOCK_ILIMIT_DEG			LCK_RETRY			
R/W-0h	R/W-0h			R/W-0h			
7	6	5	4	3	2	1	0
LCK_RETRY	I2C_CRC_ERR_MODE	MTR_LCK_MODE		MIN_VM_MODE	MAX_VM_MODE	SATURATION_FLAGS_EN	
R/W-0h	R/W-0h	R/W-0h		R/W-0h	R/W-0h	R/W-0h	

Table 8-19. FAULT_CONFIG1 Register Field Descriptions

Bit	Field	Type	Reset	Description
31	PARITY	R	0h	Parity bit

Table 8-19. FAULT_CONFIG1 Register Field Descriptions (continued)

Bit	Field	Type	Reset	Description
30-27	ILIMIT	R/W	0h	Phase current peak limit (% of BASE_CURRENT) 0h = 5% 1h = 10% 2h = 15% 3h = 20% 4h = 25% 5h = 30% 6h = 40% 7h = 45% 8h = 50% 9h = 55% Ah = 60% Bh = 65% Ch = 70% Dh = 75% Eh = 80% Fh = 85%
26-23	HW_LOCK_ILIMIT	R/W	0h	Comparator based lock detection current limit (% of BASE_CURRENT) 0h = 0% 1h = 6.7% 2h = 13.3% 3h = 20% 4h = 26.7% 5h = 33.3% 6h = 40% 7h = 46.7% 8h = 53.3% 9h = 60% Ah = 66.7% Bh = 73.3% Ch = 80% Dh = 86.7% Eh = 93.3% Fh = 100%
22-19	LOCK_ILIMIT	R/W	0h	ADC based lock detection current limit (% of BASE_CURRENT) 0h = 10% 1h = 15% 2h = 20% 3h = 25% 4h = 30% 5h = 40% 6h = 50% 7h = 55% 8h = 60% 9h = 65% Ah = 70% Bh = 75% Ch = 80% Dh = 85% Eh = 90% Fh = 95%
18	EFP_FAULT_MODE	R/W	0h	EEPROM error fault mode 0h = EEPROM fault causes latched fault; nFAULT is active; Gate driver is tristated 1h = EEPROM fault causes report only but no action is taken; nFAULT is active

Table 8-19. FAULT_CONFIG1 Register Field Descriptions (continued)

Bit	Field	Type	Reset	Description
17-15	LOCK_ILIMIT_MODE	R/W	0h	<p>Lock detection current limit fault mode</p> <p>0h = Ilimit lock detection causes latched fault; nFAULT active; Gate driver is tristated</p> <p>1h = Ilimit lock detection causes latched fault; nFAULT active; Gate driver is in low side brake mode (All low side FETs are turned ON)</p> <p>2h = Ilimit lock detection causes latched fault; nFAULT active; Gate driver is in low side brake mode (All low side FETs are turned ON)</p> <p>3h = Fault automatically cleared after LCK_RETRY time. Number of retries limited to AUTO_RETRY_TIMES. If number of retries exceed AUTO_RETRY_TIMES, fault is latched; Gate driver is tristated; nFAULT active</p> <p>4h = Fault automatically cleared for AUTO_RETRY_TIMES after LCK_RETRY time; Gate driver is in low side brake mode (All low side FETs are turned ON); nFAULT active</p> <p>5h = Fault automatically cleared after LCK_RETRY time. Number of retries limited to AUTO_RETRY_TIMES. If number of retries exceed AUTO_RETRY_TIMES, fault is latched; Gate driver is in low side brake mode (All low side FETs are turned ON); nFAULT active</p> <p>6h = Ilimit lock detection current limit is in report only but no action is taken; nFAULT active</p> <p>7h = ILIMIT LOCK is disabled</p>
14-11	LOCK_ILIMIT_DEG	R/W	0h	<p>Lock detection current limit fault deglitch time</p> <p>0h = No deglitch</p> <p>1h = 0.1ms</p> <p>2h = 0.2ms</p> <p>3h = 0.5ms</p> <p>4h = 1ms</p> <p>5h = 2.5ms</p> <p>6h = 5ms</p> <p>7h = 7.5ms</p> <p>8h = 10ms</p> <p>9h = 25ms</p> <p>Ah = 50ms</p> <p>Bh = 75ms</p> <p>Ch = 100ms</p> <p>Dh = 200ms</p> <p>Eh = 500ms</p> <p>Fh = 1000ms</p>
10-7	LCK_RETRY	R/W	0h	<p>Lock detection fault retry time</p> <p>0h = 300ms</p> <p>1h = 500ms</p> <p>2h = 1s</p> <p>3h = 2s</p> <p>4h = 3s</p> <p>5h = 4s</p> <p>6h = 5s</p> <p>7h = 6s</p> <p>8h = 7s</p> <p>9h = 8s</p> <p>Ah = 9s</p> <p>Bh = 10s</p> <p>Ch = 11s</p> <p>Dh = 12s</p> <p>Eh = 13s</p> <p>Fh = 14s</p>
6	I2C_CRC_ERR_MODE	R/W	0h	<p>I2C CRC error fault mode</p> <p>0h = CRC error on I2C causes latched fault; nFAULT is active; Gate driver is tristated</p> <p>1h = CRC error on I2C causes report only but no action is taken; nFAULT is active</p>

Table 8-19. FAULT_CONFIG1 Register Field Descriptions (continued)

Bit	Field	Type	Reset	Description
5-3	MTR_LCK_MODE	R/W	0h	Motor lock fault mode 0h = Motor lock detection causes latched fault; nFAULT active; Gate driver is tristated 1h = Motor lock detection causes latched fault; nFAULT active; Gate driver is in low side brake mode (All low side FETs are turned ON) 2h = Motor lock detection causes latched fault; nFAULT active; Gate driver is in low side brake mode (All low side FETs are turned ON) 3h = Fault automatically cleared after LCK_RETRY time. Number of retries limited to AUTO_RETRY_TIMES. If number of retries exceed AUTO_RETRY_TIMES, fault is latched; Gate driver is tristated; nFAULT active 4h = Fault automatically cleared for AUTO_RETRY_TIMES after LCK_RETRY time; Gate driver is in low side brake mode (All low side FETs are turned ON); nFAULT active 5h = Fault automatically cleared after LCK_RETRY time. Number of retries limited to AUTO_RETRY_TIMES. If number of retries exceed AUTO_RETRY_TIMES, fault is latched; Gate driver is in low side brake mode (All low side FETs are turned ON); nFAULT active 6h = Motor lock detection current limit is in report only but no action is taken; nFAULT active 7h = MTR LOCK is disabled
2	MIN_VM_MODE	R/W	0h	PVDD undervoltage fault recovery mode 0h = PVDD under voltage fault causes latched fault; nFAULT is active; Gate driver is tristated 1h = PVDD under voltage fault clears automatically if the PVDD voltage is more than (MIN_VM_MOTOR + VOLTAGE_HYSTERESIS); Gate driver is tristated; nFAULT active
1	MAX_VM_MODE	R/W	0h	PVDD overvoltage fault recovery mode 0h = PVDD over voltage fault causes latched fault; nFAULT is active; Gate driver is tristated 1h = PVDD over voltage fault clears automatically if the PVDD voltage is less than (MAX_VM_MOTOR - VOLTAGE_HYSTERESIS); Gate driver is tristated; nFAULT active
0	SATURATION_FLAGS_EN	R/W	0h	Current and speed loop saturation indication enable 0h = Disable 1h = Enable

8.2.2 FAULT_CONFIG2 Register (Offset = 92h) [Reset = 0000000h]

FAULT_CONFIG2 is shown in [Figure 8-16](#) and described in [Table 8-20](#).

Return to the [Summary Table](#).

Register to configure fault settings2

Figure 8-16. FAULT_CONFIG2 Register

31	30	29	28	27	26	25	24
PARITY	LOCK1_EN	LOCK2_EN	LOCK3_EN	LOCK_ABN_SPEED		ABNORMAL_BEMF_THR	
R-0h	R/W-0h	R/W-0h	R/W-0h	R/W-0h		R/W-0h	
23	22	21	20	19	18	17	16
ABNORMAL_BEMF_THR		NO_MTR_THR			HW_LOCK_ILIMIT_MODE		
R/W-0h		R/W-0h			R/W-0h		
15	14	13	12	11	10	9	8
HW_LOCK_ILIMIT_DEG			VOLTAGE_HYSTERESIS		MIN_VM_MOTOR		
R/W-0h			R/W-0h		R/W-0h		
7	6	5	4	3	2	1	0

Figure 8-16. FAULT_CONFIG2 Register (continued)

MIN_VM_MOTOR	MAX_VM_MOTOR	AUTO_RETRY_TIMES
R/W-0h	R/W-0h	R/W-0h

Table 8-20. FAULT_CONFIG2 Register Field Descriptions

Bit	Field	Type	Reset	Description
31	PARITY	R	0h	Parity bit
30	LOCK1_EN	R/W	0h	Lock 1 (abnormal speed fault) enable 0h = Disable 1h = Enable
29	LOCK2_EN	R/W	0h	Lock 2 (abnormal BEMF fault) enable 0h = Disable 1h = Enable
28	LOCK3_EN	R/W	0h	Lock 3 (no motor fault) enable 0h = Disable 1h = Enable
27-25	LOCK_ABN_SPEED	R/W	0h	Abnormal speed lock detection threshold (% of MAX_SPEED) 0h = 130% 1h = 140% 2h = 150% 3h = 160% 4h = 170% 5h = 180% 6h = 190% 7h = 200%
24-22	ABNORMAL_BEMF_THR	R/W	0h	Abnormal BEMF lock detection threshold (% of expected Back-EMF) Expected Back-EMF = MOTOR_BEMF_CONST × Estimated speed in Hz 0h = 40% 1h = 45% 2h = 50% 3h = 55% 4h = 60% 5h = 65% 6h = 67.5% 7h = 70%
21-19	NO_MTR_THR	R/W	0h	No motor fault condition is true if the motor phase current is less than NO_MTR_THR (% of BASE_CURRENT) 0h = 1% 1h = 2% 2h = 3% 3h = 4% 4h = 5% 5h = 7.5% 6h = 10% 7h = 20%

Table 8-20. FAULT_CONFIG2 Register Field Descriptions (continued)

Bit	Field	Type	Reset	Description
18-16	HW_LOCK_ILIMIT_MODE	R/W	0h	Hardware lock detection fault mode 0h = Hardware Ilimit lock detection causes latched fault; nFAULT active; Gate driver is tristated 1h = Hardware Ilimit lock detection causes latched fault; nFAULT active; Gate driver is in low side brake mode (All low side FETs are turned ON) 2h = Hardware Ilimit lock detection causes latched fault; nFAULT active; Gate driver is in low side brake mode (All low side FETs are turned ON) 3h = Fault automatically cleared after LCK_RETRY time. Number of retries limited to AUTO_RETRY_TIMES. If number of retries exceed AUTO_RETRY_TIMES, fault is latched; Gate driver is tristated; nFAULT active 4h = Fault automatically cleared for AUTO_RETRY_TIMES after LCK_RETRY time; Gate driver is in low side brake mode (All low side FETs are turned ON); nFAULT active 5h = Fault automatically cleared after LCK_RETRY time. Number of retries limited to AUTO_RETRY_TIMES. If number of retries exceed AUTO_RETRY_TIMES, fault is latched; Gate driver is in low side brake mode (All low side FETs are turned ON); nFAULT active 6h = Hardware Ilimit lock detection current limit is in report only but no action is taken; nFAULT active 7h = HARDWARE ILIMIT LOCK is disabled
15-13	HW_LOCK_ILIMIT_DEG	R/W	0h	Hardware lock detection current limit deglitch time 0h = Not Applicable 1h = Not Applicable 2h = 2µs 3h = 3µs 4h = 4µs 5h = 5µs 6h = 6µs 7h = 7µs
12-11	VOLTAGE_HYSTERESIS	R/W	0h	Hysteresis for PVDD overvoltage and undervoltage faults. Fault triggered at threshold, cleared at threshold ± hysteresis (+ for UV, - for OV) 0h = 1V 1h = 1.5V 2h = 2V 3h = 3V
10-7	MIN_VM_MOTOR	R/W	0h	PVDD undervoltage fault threshold (minimum DC bus voltage for running motor) 0h = No Limit 1h = 6V 2h = 7V 3h = 8V 4h = 9V 5h = 12V 6h = 14V 7h = 16V 8h = 18V 9h = 20V Ah = 24V Bh = 26V Ch = 28V Dh = 30V Eh = 32V Fh = 36V

Table 8-20. FAULT_CONFIG2 Register Field Descriptions (continued)

Bit	Field	Type	Reset	Description
6-3	MAX_VM_MOTOR	R/W	0h	PVDD overvoltage fault threshold (maximum DC bus voltage for running motor) 0h = No Limit 1h = 16V 2h = 18V 3h = 20V 4h = 22V 5h = 26V 6h = 28V 7h = 32V 8h = 34V 9h = 36V Ah = 38V Bh = 40V Ch = 44V Dh = 48V Eh = 54V Fh = 58V
2-0	AUTO_RETRY_TIMES	R/W	0h	Automatic fault retry attempts. This is used only if any of the fault mode is configured as "retry" 0h = No Limit 1h = 2 2h = 3 3h = 5 4h = 7 5h = 10 6h = 15 7h = 20

8.3 Hardware_Configuration Registers

Table 8-21 lists the memory-mapped registers for the Hardware_Configuration registers. All register offset addresses not listed in Table 8-21 should be considered as reserved locations and the register contents should not be modified.

Table 8-21. HARDWARE_CONFIGURATION Registers

Offset	Acronym	Register Name	Section
A4h	PIN_CONFIG	Hardware Pin Configuration	Section 8.3.1
A6h	DEVICE_CONFIG1	Device configuration1	Section 8.3.2
A8h	DEVICE_CONFIG2	Device configuration2	Section 8.3.3
AAh	PERI_CONFIG1	Peripheral Configuration1	Section 8.3.4
ACh	GD_CONFIG1	Gate Driver Configuration1	Section 8.3.5
AEh	GD_CONFIG2	Gate Driver Configuration2	Section 8.3.6

Complex bit access types are encoded to fit into small table cells. Table 8-22 shows the codes that are used for access types in this section.

Table 8-22. Hardware_Configuration Access Type Codes

Access Type	Code	Description
Read Type		
R	R	Read
Write Type		
W	W	Write
Reset or Default Value		
-n		Value after reset or the default value

8.3.1 PIN_CONFIG Register (Offset = A4h) [Reset = 0000000h]

PIN_CONFIG is shown in Figure 8-17 and described in Table 8-23.

Return to the [Summary Table](#).

Register to configure hardware pins

Figure 8-17. PIN_CONFIG Register

31	30	29	28	27	26	25	24
PARITY	FLUX_WEAKENING_CURRENT_RATIO			LEAD_ANGLE			
R-0h	R/W-0h			R/W-0h			
23	22	21	20	19	18	17	16
LEAD_ANGLE		MAX_POWER					
R/W-0h		R/W-0h					
15	14	13	12	11	10	9	8
MAX_POWER					FG_IDLE_CONFIG		FG_FAULT_CONFIG
R/W-0h					R/W-0h		R/W-0h
7	6	5	4	3	2	1	0
FG_FAULT_CONFIG	HALL_SNS_ST ARTUP_EN	HALL_EN	RESERVED	BRAKE_INPUT		SPEED_MODE	
R/W-0h	R/W-0h	R/W-0h	R-0h	R/W-0h		R/W-0h	

Figure 8-17. PIN_CONFIG Register (continued)

Table 8-23. PIN_CONFIG Register Field Descriptions

Bit	Field	Type	Reset	Description
31	PARITY	R	0h	Parity bit
30-28	FLUX_WEAKENING_CURRENT_RATIO	R/W	0h	Maximum flux weakening current reference (% of ILIMIT) 0h = Circular current limit 1h = 80% 2h = 70% 3h = 60% 4h = 50% 5h = 40% 6h = 30% 7h = 20%
27-22	LEAD_ANGLE	R/W	0h	Lead angle. In Modulation index control, positive value indicates the applied voltage is leading the BEMF, negative value indicates applied voltage is lagging the BEMF. In other modes, positive means positive id reference, negative means negative id reference Lead angle (degrees) 0- 31 = 1.5 × LEAD_ANGLE 32 - 63 = 1.5 × (LEAD_ANGLE -64)
21-11	MAX_POWER	R/W	0h	Maximum power (Watts) 0- 1023 = 1 × MAX_POWER 1024 - 2047 = 2 × (MAX_POWER -1024) + 1024
10-9	FG_IDLE_CONFIG	R/W	0h	FG configuration during motor idle state 0h = FG is set by last driven state 1h = FG is Hi-Z (Externally pulled up) 2h = FG is pulled to Low 3h = FG is Hi-Z (Externally pulled up)
8-7	FG_FAULT_CONFIG	R/W	0h	FG configuration during fault state. BEMF threshold defined by FG_BEMF_THR if FG_CONFIG 1 0h = FG is pulled to Low 1h = FG is Hi-Z (Externally pulled up) 2h = FG reports fault type as a unique duty cycle at 1Hz 3h = FG active till BEMF drops below BEMF threshold defined by FG_BEMF_THR if FG_CONFIG is 1
6	HALL_SNS_STARTUP_ENABLE	R/W	0h	Hall sensor-based motor startup enable 0h = Disable 1h = Enable
5	HALL_EN	R/W	0h	Hall sensor input enable 0h = Disable 1h = Enable
4	RESERVED	R	0h	Reserved
3-2	BRAKE_INPUT	R/W	0h	Brake pin mode 0h = Hardware pin BRAKE 1h = Override pin and brake according to BRAKE_PIN_MODE 2h = Override pin and do not brake / align 3h = Hardware pin BRAKE
1-0	SPEED_MODE	R/W	0h	Configure reference command mode from speed/wake pin 0h = Analog mode 1h = Controlled by duty cycle of SPEED input pin 2h = Register override mode 3h = Controlled by frequency of SPEED input pin

8.3.2 DEVICE_CONFIG1 Register (Offset = A6h) [Reset = 000XXX0h]

DEVICE_CONFIG1 is shown in [Figure 8-18](#) and described in [Table 8-24](#).

Return to the [Summary Table](#).

Register to configure device

Figure 8-18. DEVICE_CONFIG1 Register

31	30	29	28	27	26	25	24
PARITY	MTPA_EN	DAC_SOX_ANA_CONFIG		RESERVED	I2C_TARGET_ADDR		
R-0h	R/W-0h	R/W-0h		R-0h	R/W-0h		
23	22	21	20	19	18	17	16
I2C_TARGET_ADDR				EEPROM_LOCK_KEY			
R/W-0h				R/W-XXXh			
15	14	13	12	11	10	9	8
EEPROM_LOCK_KEY							
R/W-XXXh							
7	6	5	4	3	2	1	0
EEPROM_LOCK_KEY			SLEW_RATE_I2C_PINS		PULLUP_ENABLE	BUS_VOLT	
R/W-XXXh			R/W-0h		R/W-0h	R/W-0h	

Table 8-24. DEVICE_CONFIG1 Register Field Descriptions

Bit	Field	Type	Reset	Description
31	PARITY	R	0h	Parity bit
30	MTPA_EN	R/W	0h	Maximum Torque Per Ampere (MTPA) operation enable 0h = Disable 1h = Enable
29-28	DAC_SOX_ANA_CONFIG	R/W	0h	DACOUT/SOx/SPEED_ANA pin configuration 0h = DACOUT 1h = CSA_OUT 2h = ANA_ON_PIN 3h = CSA_OUT
27	RESERVED	R	0h	Reserved
26-20	I2C_TARGET_ADDR	R/W	0h	I2C target address
19-5	EEPROM_LOCK_KEY	R/W	0h	EEPROM lock access key. This value when read will always show 0
4-3	SLEW_RATE_I2C_PINS	R/W	0h	I2C pins slew rate configuration 0h = 4.8mA 1h = 3.9mA 2h = 1.86mA 3h = 30.8mA
2	PULLUP_ENABLE	R/W	0h	Internal pull-up to AVDD enable for nFAULT and FG pins 0h = Disable 1h = Enable
1-0	BUS_VOLT	R/W	0h	Maximum PVDD voltage configuration. Voltage gain = 20V/V, BUS_VOLT = 60 Voltage gain = 10V/V, BUS_VOLT = 30 Voltage gain = 5V/V, BUS_VOLT = 15 0h = 15V 1h = 30V 2h = 60V 3h = Not defined

8.3.3 DEVICE_CONFIG2 Register (Offset = A8h) [Reset = 00000000h]

DEVICE_CONFIG2 is shown in [Figure 8-19](#) and described in [Table 8-25](#).

Return to the [Summary Table](#).

Register to configure device

Figure 8-19. DEVICE_CONFIG2 Register

31	30	29	28	27	26	25	24
PARITY		INPUT_MAXIMUM_FREQ					
R-0h		R/W-0h					
23	22	21	20	19	18	17	16
INPUT_MAXIMUM_FREQ							
R/W-0h							
15	14	13	12	11	10	9	8
SLEEP_ENTRY_TIME		LIMP_HOME_EN	DYNAMIC_VOLTAGE_GAIN_EN	DEV_MODE	PWM_DITHER_DEPTH		EXT_CLK_EN
R/W-0h		R/W-0h	R/W-0h	R/W-0h	R/W-0h		R/W-0h
7	6	5	4	3	2	1	0
EXT_CLK_CONFIG			EXT_WD_EN	EXT_WD_CONFIG		EXT_WD_INPUT_MODE	EXT_WD_FAULT_MODE
R/W-0h			R/W-0h	R/W-0h		R/W-0h	R/W-0h

Table 8-25. DEVICE_CONFIG2 Register Field Descriptions

Bit	Field	Type	Reset	Description
31	PARITY	R	0h	Parity bit
30-16	INPUT_MAXIMUM_FREQ	R/W	0h	Speed pin input frequency configuration for frequency control mode that corresponds to 100% duty cycle Input duty cycle = Input frequency / INPUT_MAXIMUM_FREQ
15-14	SLEEP_ENTRY_TIME	R/W	0h	Sleep command detection time. (Refer Table: Conditions to Enter or Exit Sleep Modes) 0h = 50µs 1h = 200µs 2h = 20ms 3h = 200ms
13	LIMP_HOME_EN	R/W	0h	Limp home mode enable 0h = Disable 1h = Enable
12	DYNAMIC_VOLTAGE_GAIN_EN	R/W	0h	Dynamic voltage gain adjustment enable 0h = Disable 1h = Enable
11	DEV_MODE	R/W	0h	Device mode select 0h = Standby mode 1h = Sleep mode
10-9	PWM_DITHER_DEPTH	R/W	0h	PWM dither depth 0h = PWM dither disabled 1h = 5% 2h = 7.5% 3h = 10%
8	EXT_CLK_EN	R/W	0h	External clock mode enable 0h = Disable 1h = Enable

Table 8-25. DEVICE_CONFIG2 Register Field Descriptions (continued)

Bit	Field	Type	Reset	Description
7-5	EXT_CLK_CONFIG	R/W	0h	External clock frequency 0h = 8kHz 1h = 16kHz 2h = 32kHz 3h = 64kHz 4h = 128kHz 5h = 256kHz 6h = 512kHz 7h = 1024kHz
4	EXT_WD_EN	R/W	0h	External watchdog enable 0h = Disable 1h = Enable
3-2	EXT_WD_CONFIG	R/W	0h	Time between watchdog tickles 0h = 1s 1h = 2s 2h = 5s 3h = 10s
1	EXT_WD_INPUT_MODE	R/W	0h	External watchdog input source 0h = Watchdog tickle over I2C 1h = Not Applicable
0	EXT_WD_FAULT_MODE	R/W	0h	External watchdog fault mode 0h = External watchdog fault causes report only but no action is taken; nFAULT is active 1h = External watchdog fault causes latched fault; nFAULT is active; Gate driver is tristated

8.3.4 PERI_CONFIG1 Register (Offset = AAh) [Reset = 4000000h]

PERI_CONFIG1 is shown in [Figure 8-20](#) and described in [Table 8-26](#).

Return to the [Summary Table](#).

Register to peripheral1

Figure 8-20. PERI_CONFIG1 Register

31	30	29	28	27	26	25	24
PARITY	SPREAD_SPE CTRUM_MODU LATION_DIS	DIG_DEAD_TIME				CLOCK_FREQUENCY	
R-0h	R/W-1h	R/W-0h				R/W-0h	
23	22	21	20	19	18	17	16
VDC_FILTER	BUS_POWER LIMIT_ENABLE	DIR_INPUT		DIR_CHANGE_ MODE	SPEED_LIMIT_ ENABLE	RESERVED	
R/W-0h	R/W-0h	R/W-0h		R/W-0h	R/W-0h	R/W-0h	R-0h
15	14	13	12	11	10	9	8
ACTIVE_BRAKE_SPEED_DELTA_LIMIT_ENTRY			PWM_DITHER_ MODE	PWM_DITHER_STEP		SPEED_RANG E_SEL	NO_MTR_FLT_ CLOSEDLOOP_ DIS
R/W-0h			R/W-0h	R/W-0h		R/W-0h	R/W-0h
7	6	5	4	3	2	1	0
FLUX_WEAKENING_REFEREN CE		CTRL_MODE		SALIENCY_PERCENTAGE			
R/W-0h		R/W-0h		R/W-0h			

Table 8-26. PERI_CONFIG1 Register Field Descriptions

Bit	Field	Type	Reset	Description
31	PARITY	R	0h	Parity bit
30	SPREAD_SPECTRUM_MODULATION_DIS	R/W	1h	Spread Spectrum Modulation (SSM) disable 0h = SSM is enabled 1h = SSM is disabled
29-26	DIG_DEAD_TIME	R/W	0h	PWM dead time configuration 0h = Not Applicable 1h = Not Applicable 2h = 100ns 3h = 150ns 4h = 200ns 5h = 250ns 6h = 300ns 7h = 350ns 8h = 400ns 9h = 450ns Ah = 500ns Bh = 600ns Ch = 700ns Dh = 800ns Eh = 900ns Fh = 1000ns
25-24	CLOCK_FREQUENCY	R/W	0h	System clock frequency configuration 0h = High 1h = Medium 2h = Low 3h = Reserved
23-22	VDC_FILTER	R/W	0h	PVDD voltage filter coefficient 0h = Disable 1h = Enable with default filter cut-off frequency 2h = Enable with filter cut-off frequency 100Hz 3h = Enable with filter cut-off frequency 1000Hz
21	BUS_POWER_LIMIT_ENABLE	R/W	0h	Bus power limit enable (Limits input DC bus power to MAX_POWER except if CTRL_MODE = 1h) 0h = Disable 1h = Enable
20-19	DIR_INPUT	R/W	0h	Direction (DIR) pin override 0h = Hardware Pin DIR 1h = Override DIR pin with clockwise rotation OUTA-OUTB-OUTC 2h = Override DIR pin with counter clockwise rotation OUTA-OUTC-OUTB 3h = Hardware Pin DIR
18	DIR_CHANGE_MODE	R/W	0h	Response to direction change command (Refer Figure: Motor Starting-up Flow) 0h = Follow motor stop options and ISD routine on detecting DIR change 1h = Change the direction through reverse drive while continuously driving the motor
17	SPEED_LIMIT_ENABLE	R/W	0h	Motor speed limit enable (Limits motor speed to MAX_SPEED except if CTRL_MODE = 0h) 0h = Disable 1h = Enable
16	RESERVED	R	0h	Reserved

Table 8-26. PERI_CONFIG1 Register Field Descriptions (continued)

Bit	Field	Type	Reset	Description
15-13	ACTIVE_BRAKE_SPEED_DELTA_LIMIT_ENTRY	R/W	0h	Difference between final speed and present speed below which active braking will be applied (% of MAX_SPEED) 0h = 20% 1h = 30% 2h = 40% 3h = 50% 4h = 60% 5h = 70% 6h = 80% 7h = 90%
12	PWM_DITHER_MODE	R/W	0h	PWM dither mode 0h = Triangular mode 1h = Random mode
11-10	PWM_DITHER_STEP	R/W	0h	PWM dither step 0h = 1 1h = 2 2h = 5 3h = 10
9	SPEED_RANGE_SEL	R/W	0h	Frequency range selection for PWM duty mode reference input (SPEED_MODE = 1h) 0h = 325Hz to 100kHz speed PWM input 1h = 10Hz to 325Hz speed PWM input
8	NO_MTR_FLT_CLOSEDLOOP_DIS	R/W	0h	No motor fault detection enable in closed-loop 0h = Enable No motor fault in closed loop if LOCK2_EN is set to 0x1 1h = Disable No Motor fault in closed loop
7-6	FLUX_WEAKENING_REFERENCE	R/W	0h	Modulation index reference to be tracked in flux weakening mode 0h = 70% 1h = 80% 2h = 90% 3h = 95%
5-4	CTRL_MODE	R/W	0h	Control mode 0h = Speed control 1h = Power control 2h = Current control 3h = Modulation index control
3-0	SALIENCY_PERCENTAGE	R/W	0h	Motor saliency in percentage calculated as $((L_q - L_d) \times 100) / (4 \times (L_q + L_d))$ Example: $L_q = 2\text{mH}$ and $L_d = 1\text{mH}$ then SALIENCY_PERCENTAGE = $100/12 = 8.33$ (Configure 8)

8.3.5 GD_CONFIG1 Register (Offset = ACh) [Reset = 0000000h]

GD_CONFIG1 is shown in [Figure 8-21](#) and described in [Table 8-27](#).

Return to the [Summary Table](#).

Register to configure gated driver settings1

Figure 8-21. GD_CONFIG1 Register

31	30	29	28	27	26	25	24
PARITY	RESERVED					BST_CHRG_TIME	
R-0h	R-0h					R/W-0h	
23	22	21	20	19	18	17	16
SNS_FLT_MOD_E	VDS_FLT_MOD_E	BST_UV_MOD_E	GVDD_UV_MODAL	AVDD_VOL_SE_L	RESERVED	RESERVED	DIS_BST_FLT
R/W-0h	R/W-0h	R/W-0h	R/W-0h	R/W-0h	R-0h	R-0h	R/W-0h
15	14	13	12	11	10	9	8

Figure 8-21. GD_CONFIG1 Register (continued)

OTS_AUTO_RECOVERY	RESERVED				DIS_SNS_FLT	DIS_VDS_FLT
R/W-0h	R-0h				R/W-0h	R/W-0h
7	6	5	4	3	2	1 0
RESERVED	SEL_VDS_LVL			RESERVED	CSA_GAIN	
R-0h	R/W-0h			R-0h	R/W-0h	

Table 8-27. GD_CONFIG1 Register Field Descriptions

Bit	Field	Type	Reset	Description
31	PARITY	R	0h	Parity bit
30-26	RESERVED	R	0h	Reserved
25-24	BST_CHRG_TIME	R/W	0h	Bootstrap capacitor charging time 0h = 0ms 1h = 3ms 2h = 6ms 3h = 12ms
23	SNS_FLT_MODE	R/W	0h	Current sense overcurrent fault mode 0h = Current sense overcurrent fault causes latched fault; nFAULT active; Gate driver is tristated 1h = Fault automatically cleared after LCK_RETRY time. Number of retries limited to AUTO_RETRY_TIMES. If number of retries exceed AUTO_RETRY_TIMES, fault is latched; Gate driver is tristated; nFAULT active
22	VDS_FLT_MODE	R/W	0h	VDS overcurrent fault response mode 0h = VDS overcurrent fault causes latched fault; nFAULT active; Gate driver is tristated 1h = Fault automatically cleared after LCK_RETRY time. Number of retries limited to AUTO_RETRY_TIMES. If number of retries exceed AUTO_RETRY_TIMES, fault is latched; Gate driver is tristated; nFAULT active
21	BST_UV_MODE	R/W	0h	Bootstrap undervoltage fault mode 0h = Bootstrap undervoltage fault causes latched fault; nFAULT active; Gate driver is tristated 1h = Fault automatically cleared after LCK_RETRY time. Number of retries limited to AUTO_RETRY_TIMES. If number of retries exceed AUTO_RETRY_TIMES, fault is latched; Gate driver is tristated; nFAULT active
20	GVDD_UV_MODE	R/W	0h	GVDD undervoltage fault mode 0h = GVDD undervoltage fault causes latched fault; nFAULT active; Gate driver is tristated 1h = Fault automatically cleared after LCK_RETRY time. Number of retries limited to AUTO_RETRY_TIMES. If number of retries exceed AUTO_RETRY_TIMES, fault is latched; Gate driver is tristated; nFAULT active
19	AVDD_VOL_SEL	R/W	0h	AVDD voltage level selection 0h = 3.3V 1h = 5V
18	RESERVED	R	0h	Reserved
17	RESERVED	R	0h	Reserved
16	DIS_BST_FLT	R/W	0h	Bootstrap fault detection disable 0h = Enable BST fault 1h = Disable BST fault
15	OTS_AUTO_RECOVERY	R/W	0h	Over-temperature shutdown (OTS) auto recovery enable 0h = OTS fault causes latched fault; nFAULT active; Gate driver is tristated 1h = OTS fault clears automatically if (TJ < TOTSD – THYS); Gate driver is tristated; nFAULT active
14-10	RESERVED	R	0h	Reserved

Table 8-27. GD_CONFIG1 Register Field Descriptions (continued)

Bit	Field	Type	Reset	Description
9	DIS_SNS_FLT	R/W	0h	Current sense fault detection disable 0h = Enable SNS OCP fault 1h = Disable SNS OCP fault
8	DIS_VDS_FLT	R/W	0h	VDS fault detection disable 0h = Enable VDS fault 1h = Disable VDS fault
7	RESERVED	R	0h	Reserved
6-3	SEL_VDS_LVL	R/W	0h	VDS overcurrent protection threshold 0h = 0.06V 1h = 0.12V 2h = 0.18V 3h = 0.24V 4h = 0.3V 5h = 0.36V 6h = 0.42V 7h = 0.48V 8h = 0.6V 9h = 0.8V Ah = 1V Bh = 1.2V Ch = 1.4V Dh = 1.6V Eh = 1.8V Fh = 2V
2	RESERVED	R	0h	Reserved
1-0	CSA_GAIN	R/W	0h	Current Sense Amplifier (CSA) gain 0h = 5V/V 1h = 10V/V 2h = 20V/V 3h = 40V/V

8.3.6 GD_CONFIG2 Register (Offset = AEh) [Reset = 0000000h]

GD_CONFIG2 is shown in [Figure 8-22](#) and described in [Table 8-28](#).

Return to the [Summary Table](#).

Register to configure gated driver settings2

Figure 8-22. GD_CONFIG2 Register

31	30	29	28	27	26	25	24
PARITY	RESERVED						
R-0h				R-0h			
23	22	21	20	19	18	17	16
RESERVED							
R-0h							
15	14	13	12	11	10	9	8
RESERVED	BASE_CURRENT						
R-0h				R/W-0h			
7	6	5	4	3	2	1	0
BASE_CURRENT							
R/W-0h							

Table 8-28. GD_CONFIG2 Register Field Descriptions

Bit	Field	Type	Reset	Description
31	PARITY	R	0h	Parity bit
30-15	RESERVED	R	0h	Reserved
14-0	BASE_CURRENT	R/W	0h	Base current calculated based on gain settings Base current in Ampere = $1.5 / (RSENSE \times CSA_GAIN)$ BASE_CURRENT = Base current in Ampere \times 32768/1200 Example: for 30A, enter $30 \times 32768 / 1200 = 820$

8.4 Internal_Algorithm_Configuration Registers

Table 8-29 lists the memory-mapped registers for the Internal_Algorithm_Configuration registers. All register offset addresses not listed in Table 8-29 should be considered as reserved locations and the register contents should not be modified.

Table 8-29. INTERNAL_ALGORITHM_CONFIGURATION Registers

Offset	Acronym	Register Name	Section
A0h	INT_ALGO_1	Internal Algorithm Configuration1	Section 8.4.1
A2h	INT_ALGO_2	Internal Algorithm Configuration2	Section 8.4.2

Complex bit access types are encoded to fit into small table cells. Table 8-30 shows the codes that are used for access types in this section.

Table 8-30. Internal_Algorithm_Configuration Access Type Codes

Access Type	Code	Description
Read Type		
R	R	Read
Write Type		
W	W	Write
Reset or Default Value		
-n		Value after reset or the default value

8.4.1 INT_ALGO_1 Register (Offset = A0h) [Reset = 0000000h]

INT_ALGO_1 is shown in Figure 8-23 and described in Table 8-31.

Return to the [Summary Table](#).

Register to configure internal algorithm parameters1

Figure 8-23. INT_ALGO_1 Register

31	30	29	28	27	26	25	24
PARITY	ABNORMAL_BEMF_PERSISTENT_TIME		SPEED_PIN_GLITCH_FILTER		FAST_ISD_EN	ISD_STOP_TIME	
R-0h	R/W-0h		R/W-0h		R/W-0h	R/W-0h	
23	22	21	20	19	18	17	16
ISD_RUN_TIME		ISD_TIMEOUT		DRY_RUN_TDEG			DRY_RUN_ILIM_FIFTY_PERCENT_SPEED
R/W-0h		R/W-0h		R/W-0h			R/W-0h
15	14	13	12	11	10	9	8
DRY_RUN_ILIM_FIFTY_PERCENT_SPEED			DRY_RUN_ILIM				
R/W-0h			R/W-0h				
7	6	5	4	3	2	1	0
DRY_RUN_SPEED_THR		DRY_RUN_ILIM_MODE	DRY_RUN_MODE		REV_DRV_OPEN_LOOP_DEC		
R/W-0h		R/W-0h	R/W-0h		R/W-0h		

Table 8-31. INT_ALGO_1 Register Field Descriptions

Bit	Field	Type	Reset	Description
31	PARITY	R	0h	Parity bit
30-29	ABNORMAL_BEMF_PERSISTENT_TIME	R/W	0h	Deglitch time for abnormal BEMF fault detection 0h = 2 electrical cycles 1h = 500ms 2h = 1000ms 3h = 2000ms
28-27	SPEED_PIN_GLITCH_FILTER	R/W	0h	Glitch filter applied on SPEED/WAKE pin(Applicable when SPEED_MODE = 1h or SPEED_MODE =3h) 0h = No Glitch Filter 1h = 0.2µs 2h = 0.5µs 3h = 1.0µs
26	FAST_ISD_EN	R/W	0h	Fast speed detection enable during ISD 0h = Disable 1h = Enable
25-24	ISD_STOP_TIME	R/W	0h	Persistence time for declaring motor has stopped during ISD 0h = 1ms 1h = 5ms 2h = 50ms 3h = 100ms
23-22	ISD_RUN_TIME	R/W	0h	Persistence time for declaring motor is running during ISD 0h = 1ms 1h = 5ms 2h = 50ms 3h = 100ms
21-20	ISD_TIMEOUT	R/W	0h	Timeout in case ISD is unable to reliably detect speed or direction 0h = 500ms 1h = 750ms 2h = 1000ms 3h = 2000ms
19-17	DRY_RUN_TDEG	R/W	0h	Dry run fault detection deglitch time 0h = 10s 1h = 30s 2h = 1 min 3h = 2 min 4h = 3 min 5h = 5 min 6h = 10 min 7h = 15 min
16-13	DRY_RUN_ILIM_FIFTY_PERCENT_SPEED	R/W	0h	Current limit threshold for dry run detection at 50% of maximum speed (% of ILIMIT) 0h = 5% 1h = 7.5% 2h = 10% 3h = 12.5% 4h = 15% 5h = 17.5% 6h = 20% 7h = 22.5% 8h = 25% 9h = 27.5% Ah = 30% Bh = 32.5% Ch = 35% Dh = 40% Eh = 45% Fh = 50%

Table 8-31. INT_ALGO_1 Register Field Descriptions (continued)

Bit	Field	Type	Reset	Description
12-8	DRY_RUN_ILIM	R/W	0h	Current limit threshold for dry run detection (% of ILIMIT) 0h = 2.5% 1h = 5% 2h = 7.5% 3h = 10% 4h = 12.5% 5h = 15% 6h = 17.5% 7h = 20% 8h = 22.5% 9h = 25% Ah = 27.5% Bh = 30% Ch = 32.5% Dh = 35% Eh = 37.5% Fh = 40% 10h = 42.5% 11h = 45% 12h = 47.5% 13h = 50% 14h = 52.5% 15h = 55% 16h = 57.5% 17h = 60% 18h = 62.5% 19h = 65% 1Ah = 67.5% 1Bh = 70% 1Ch = 72.5% 1Dh = 75% 1Eh = 77.5% 1Fh = 80%
7-6	DRY_RUN_SPEED_THR	R/W	0h	Minimum speed threshold above which enable bit is active for dry run detection (% of MAX_SPEED) 0h = 25% 1h = 40% 2h = 50% 3h = 60%
5	DRY_RUN_ILIM_MODE	R/W	0h	Dry run detection current limit mode 0h = Current limit threshold is constant 1h = Current limit threshold varies with speed
4-3	DRY_RUN_MODE	R/W	0h	Dry run detection fault response mode 0h = Dry run detection is disabled 1h = Dry run detection fault is in report only but no action is taken; nFAULT active 2h = Fault automatically cleared after LCK_RETRY time. Number of retries limited to AUTO_RETRY_TIMES. If number of retries exceed AUTO_RETRY_TIMES, fault is latched; Gate driver is tristated; nFAULT active 3h = Dry run detection fault causes latched fault; nFAULT active; Gate driver is tristated
2-0	REV_DRV_OPEN_LOOP_DEC	R/W	0h	Open-loop deceleration rate in reverse drive (% of open-loop acceleration) 0h = 50% 1h = 60% 2h = 70% 3h = 80% 4h = 90% 5h = 100% 6h = 125% 7h = 150%

8.4.2 INT_ALGO_2 Register (Offset = A2h) [Reset = 0000000h]

INT_ALGO_2 is shown in [Figure 8-24](#) and described in [Table 8-32](#).

Return to the [Summary Table](#).

Register to configure internal algorithm parameters2

Figure 8-24. INT_ALGO_2 Register

31	30	29	28	27	26	25	24
PARITY		FLUX_WEAKENING_KP					
R-0h		R/W-0h					
23	22	21	20	19	18	17	16
FLUX_WEAKENING_KP			FLUX_WEAKENING_KI				
R/W-0h			R/W-0h				
15	14	13	12	11	10	9	8
FLUX_WEAKENING_KI				FLUX_WEAKENING_EN		CL_SLOW_ACC	
R/W-0h				R/W-0h		R/W-0h	
7	6	5	4	3	2	1	0
CL_SLOW_ACC		ACTIVE_BRAKE_BUS_CURRENT_SLEW_RATE			EEPROM_LOCK_MODE		DYNAMIC_SAMPLING_EN
R/W-0h		R/W-0h			R/W-0h		R/W-0h

Table 8-32. INT_ALGO_2 Register Field Descriptions

Bit	Field	Type	Reset	Description
31	PARITY	R	0h	Parity bit
30-21	FLUX_WEAKENING_KP	R/W	0h	10-bit value for flux weakening Kp FLUX_WEAKENING_KP is divided in 2 sections - SCALE(9:8) and VALUE(7:0) $K_p = 0.1 \times \text{VALUE} / 10^{\text{SCALE}}$.
20-11	FLUX_WEAKENING_KI	R/W	0h	10-bit value for flux weakening Ki FLUX_WEAKENING_KI is divided in 2 sections - SCALE(9:8) and VALUE(7:0) $K_i = 10.0 \times \text{VALUE} / 10^{\text{SCALE}}$.
10	FLUX_WEAKENING_EN	R/W	0h	Flux weakening enable 0h = Disable 1h = Enable

Table 8-32. INT_ALGO_2 Register Field Descriptions (continued)

Bit	Field	Type	Reset	Description
9-6	CL_SLOW_ACC	R/W	0h	Closed loop acceleration when estimator is not yet fully aligned (Applicable only if CTRL_MODE = 0h) and acceleration/deacceleration during BUS_POWER_LIMIT_ENABLE = 1h or SPEED_LIMIT_ENABLE = 1h Speed control (Hz/s) Power control (W/s) Current control (0.1A/s) Modulation index control(0.01% modulation index/s) 0h = 0.1 1h = 1 2h = 2 3h = 3 4h = 5 5h = 10 6h = 20 7h = 30 8h = 40 9h = 50 Ah = 100 Bh = 200 Ch = 500 Dh = 750 Eh = 1000 Fh = 2000
5-3	ACTIVE_BRAKE_BUS_CURRENT_SLEW_RATE	R/W	0h	Active braking bus current slew rate 0h = 10A/s 1h = 50A/s 2h = 100A/s 3h = 250A/s 4h = 500A/s 5h = 1000A/s 6h = 5000A/s 7h = No Limit
2-1	EEPROM_LOCK_MODE	R/W	0h	EEPROM access lock mode 0h = EEPROM read and write allowed without a valid EEPROM_LOCK_KEY 1h = EEPROM read and write allowed with a valid EEPROM_LOCK_KEY 2h = EEPROM read allowed with a valid EEPROM_LOCK_KEY, write is locked permanently 3h = EEPROM read and write is locked permanently
0	DYNAMIC_SAMPLING_ENABLE	R/W	0h	Dynamic sampling enable 0h = Dynamic sampling is disabled 1h = Dynamic sampling is enabled

9 RAM (Volatile) Register Map

9.1 Fault_Status Registers

Table 9-1 lists the memory-mapped registers for the Fault_Status registers. All register offset addresses not listed in Table 9-1 should be considered as reserved locations and the register contents should not be modified.

Table 9-1. FAULT_STATUS Registers

Offset	Acronym	Register Name	Section
0h	GATE_DRIVER_FAULT_STATUS	Fault Status Register	Section 9.1.1
2h	CONTROLLER_FAULT_STATUS	Fault Status Register	Section 9.1.2
24Ch	EEPROM_FAULT_STATUS	EEPROM Fault Status Register	Section 9.1.3

Complex bit access types are encoded to fit into small table cells. Table 9-2 shows the codes that are used for access types in this section.

Table 9-2. Fault_Status Access Type Codes

Access Type	Code	Description
Read Type		
R	R	Read
Reset or Default Value		
-n		Value after reset or the default value

9.1.1 GATE_DRIVER_FAULT_STATUS Register (Offset = 0h) [Reset = 0000000h]

GATE_DRIVER_FAULT_STATUS is shown in Figure 9-1 and described in Table 9-3.

Return to the [Summary Table](#).

Status of various gate driver faults

Figure 9-1. GATE_DRIVER_FAULT_STATUS Register

31	30	29	28	27	26	25	24
DRIVER_FAULT	RESERVED	OTS_FAULT	OCP_VDS_FAULT	OCP_SNS_FAULT	BST_UV_FAULT	GVDD_UV_FLT	DRV_OFF
R-0h	R-0h	R-0h	R-0h	R-0h	R-0h	R-0h	R-0h
23	22	21	20	19	18	17	16
RESERVED							
R-0h							
15	14	13	12	11	10	9	8
RESERVED							
R-0h							
7	6	5	4	3	2	1	0
RESERVED	VDS_LC_FAULT	VDS_LB_FAULT	VDS_LA_FAULT	RESERVED	VDS_HC_FAULT	VDS_HB_FAULT	VDS_HA_FAULT
R-0h	R-0h	R-0h	R-0h	R-0h	R-0h	R-0h	R-0h

Table 9-3. GATE_DRIVER_FAULT_STATUS Register Field Descriptions

Bit	Field	Type	Reset	Description
31	DRIVER_FAULT	R	0h	Indicates the logical OR of driver fault registers 0h = No Gate Driver fault condition is detected 1h = Gate Driver fault condition is detected
30	RESERVED	R	0h	Reserved

Table 9-3. GATE_DRIVER_FAULT_STATUS Register Field Descriptions (continued)

Bit	Field	Type	Reset	Description
29	OTS_FAULT	R	0h	Overtemperature fault 0h = No overtemperature warning / shutdown is detected 1h = Overtemperature warning / shutdown is detected
28	OCP_VDS_FAULT	R	0h	Overcurrent VDS fault status 0h = No VDS fault condition is detected 1h = VDS fault condition is detected
27	OCP_SNS_FAULT	R	0h	Overcurrent sense fault status 0h = No overcurrent sense fault condition is detected 1h = Overcurrent sense fault condition is detected
26	BST_UV_FAULT	R	0h	Bootstrap undervoltage protection status 0h = No BST undervoltage fault condition is detected 1h = BST undervoltage fault condition is detected
25	GVDD_UV_FLT	R	0h	GVDD undervoltage fault status 0h = No GVDD undervoltage fault condition is detected 1h = GVDD undervoltage fault condition is detected
24	DRV_OFF	R	0h	DRV off status 0h = DRV is ON 1h = DRVOff state detected
23-7	RESERVED	R	0h	Reserved
6	VDS_LC_FAULT	R	0h	VDS fault status on low-side switch of OUTC 0h = No VDS fault detected on low-side switch of OUTC 1h = VDS fault detected on low-side switch of OUTC
5	VDS_LB_FAULT	R	0h	VDS fault status on low-side switch of OUTB 0h = No VDS fault detected on low-side switch of OUTB 1h = VDS fault detected on low-side switch of OUTB
4	VDS_LA_FAULT	R	0h	VDS fault status on low-side switch of OUTA 0h = No VDS fault detected on low-side switch of OUTA 1h = VDS fault detected on low-side switch of OUTA
3	RESERVED	R	0h	Reserved
2	VDS_HC_FAULT	R	0h	VDS fault status on high-side switch of OUTC 0h = No VDS fault detected on high-side switch of OUTC 1h = VDS fault detected on high-side switch of OUTC
1	VDS_HB_FAULT	R	0h	VDS fault status on high-side switch of OUTB 0h = No VDS fault detected on high-side switch of OUTB 1h = VDS fault detected on high-side switch of OUTB
0	VDS_HA_FAULT	R	0h	VDS fault status on high-side switch of OUTA 0h = No VDS fault detected on high-side switch of OUTA 1h = VDS fault detected on high-side switch of OUTA

9.1.2 CONTROLLER_FAULT_STATUS Register (Offset = 2h) [Reset = 0000000h]

CONTROLLER_FAULT_STATUS is shown in [Figure 9-2](#) and described in [Table 9-4](#).

Return to the [Summary Table](#).

Status of various controller faults

Figure 9-2. CONTROLLER_FAULT_STATUS Register

31	30	29	28	27	26	25	24
CONTROLLER_FAULT	RESERVED	RESERVED	RESERVED	NO_MTR_PHA_SE_C	NO_MTR_PHA_SE_B	NO_MTR_PHA_SE_A	MPET_BEMF_FAULT
R-0h	R-0h	R-0h	R-0h	R-0h	R-0h	R-0h	R-0h
23	22	21	20	19	18	17	16
ABN_SPEED	ABN_BEMF	NO_MTR	MTR_LCK	LOCK_LIMIT	HW_LOCK_LIMIT	DCBUS_UNDE R_VOLTAGE	DCBUS_OVER_VOLTAGE

Figure 9-2. CONTROLLER_FAULT_STATUS Register (continued)

R-0h	R-0h	R-0h	R-0h	R-0h	R-0h	R-0h	R-0h
15	14	13	12	11	10	9	8
SPEED_LOOP_SATURATION	CURRENT_LOOP_SATURATION	MAX_SPEED_SATURATION	BUS_POWER_LIMIT_SATURATION	EEPROM_WRITE_LOCK_SET	EEPROM_READ_LOCK_SET	DRY_RUN_DETECTION_STATUS	RESERVED
R-0h	R-0h	R-0h	R-0h	R-0h	R-0h	R-0h	R-0h
7	6	5	4	3	2	1	0
RESERVED	I2C_CRC_FAULT_STATUS	EEPROM_ERR_STATUS	BOOT_STL_FAULT	WATCHDOG_FAULT	CPU_RESET_FAULT_STATUS	WWDT_FAULT_STATUS	RESERVED
R-0h	R-0h	R-0h	R-0h	R-0h	R-0h	R-0h	R-0h

Table 9-4. CONTROLLER_FAULT_STATUS Register Field Descriptions

Bit	Field	Type	Reset	Description
31	CONTROLLER_FAULT	R	0h	Indicates the logical OR of controller fault status registers
30	RESERVED	R	0h	Reserved
29	RESERVED	R	0h	Reserved
28	RESERVED	R	0h	Reserved
27	NO_MTR_PHASE_C	R	0h	Indicates loss of Phase C causes no motor fault
26	NO_MTR_PHASE_B	R	0h	Indicates loss of Phase B causes no motor fault
25	NO_MTR_PHASE_A	R	0h	Indicates loss of Phase A causes no motor fault
24	MPET_BEMF_FAULT	R	0h	Indicates an error during BEMF constant measurement
23	ABN_SPEED	R	0h	Indicates abnormal speed motor lock condition
22	ABN_BEMF	R	0h	Indicates abnormal BEMF motor lock condition
21	NO_MTR	R	0h	Indicates no motor (loss of phase) fault
20	MTR_LCK	R	0h	Indicates when one of the motor lock (abnormal BEMF/speed, no motor) is triggered
19	LOCK_LIMIT	R	0h	Indicates Lock limit fault
18	HW_LOCK_LIMIT	R	0h	Indicates Hardware lock limit fault
17	DCBUS_UNDER_VOLTAGE	R	0h	Indicates configurable under voltage fault on PVDD
16	DCBUS_OVER_VOLTAGE	R	0h	Indicates configurable over voltage fault on PVDD
15	SPEED_LOOP_SATURATION	R	0h	Indicates speed loop saturation
14	CURRENT_LOOP_SATURATION	R	0h	Indicates current loop saturation
13	MAX_SPEED_SATURATION	R	0h	Indicates maximum speed limit saturation
12	BUS_POWER_LIMIT_SATURATION	R	0h	Indicates maximum (input DC bus) power limit saturation
11	EEPROM_WRITE_LOCK_SET	R	0h	Indicates EEPROM write lock is set
10	EEPROM_READ_LOCK_SET	R	0h	Indicates EEPROM read lock is set
9	DRY_RUN_DETECTION_STATUS	R	0h	Indicates dry run detection
8-7	RESERVED	R	0h	Reserved
6	I2C_CRC_FAULT_STATUS	R	0h	Indicates CRC fault in I2C packet
5	EEPROM_ERR_STATUS	R	0h	Indicates error in EEPROM

Table 9-4. CONTROLLER_FAULT_STATUS Register Field Descriptions (continued)

Bit	Field	Type	Reset	Description
4	BOOT_STL_FAULT	R	0h	Indicates self test fault during boot-up (applicable to MCF8329HSULIREER only)
3	WATCHDOG_FAULT	R	0h	indicates Watchdog fault
2	CPU_RESET_FAULT_ST ATUS	R	0h	Indicates unexpected CPU reset fault (applicable to MCF8329HSULIREER only)
1	WWDT_FAULT_STATUS	R	0h	Indicates windowed watchdog reset fault (applicable to MCF8329HSULIREER only)
0	RESERVED	R	0h	Reserved

9.1.3 EEPROM_FAULT_STATUS Register (Offset = 24Ch) [Reset = 0000h]

EEPROM_FAULT_STATUS is shown in [Figure 9-3](#) and described in [Table 9-5](#).

Return to the [Summary Table](#).

EEPROM Fault Status Register

Figure 9-3. EEPROM_FAULT_STATUS Register

15	14	13	12	11	10	9	8
RESERVED							
R-0h							
7	6	5	4	3	2	1	0
RESERVED			EEPROM_CRC _FLT_STS	RESERVED	EEPROM_PARI TY_FLT_STS	RESERVED	RESERVED
R-0h			R-0h	R-0h	R-0h	R-0h	R-0h

Table 9-5. EEPROM_FAULT_STATUS Register Field Descriptions

Bit	Field	Type	Reset	Description
15-5	RESERVED	R	0h	Reserved
4	EEPROM_CRC_FLT_STS	R	0h	EEPROM CRC error fault status 0h = EEPROM CRC Error fault condition is not detected 1h = EEPROM CRC Error fault condition is detected
3	RESERVED	R	0h	Reserved
2	EEPROM_PARITY_FLT_S TS	R	0h	EEPROM parity error fault status 0h = EEPROM Parity error fault condition is not detected 1h = EEPROM Parity error fault condition is detected
1	RESERVED	R	0h	Reserved
0	RESERVED	R	0h	Reserved

9.2 System_Status Registers

Table 9-6 lists the memory-mapped registers for the System_Status registers. All register offset addresses not listed in Table 9-6 should be considered as reserved locations and the register contents should not be modified.

Table 9-6. SYSTEM_STATUS Registers

Offset	Acronym	Register Name	Section
E4h	ALGO_STATUS	System Status Register	Section 9.2.1
E6h	MTR_PARAMS	System Status Register	Section 9.2.2
E8h	ALGO_STATUS_MPET	System Status Register	Section 9.2.3

Complex bit access types are encoded to fit into small table cells. Table 9-7 shows the codes that are used for access types in this section.

Table 9-7. System_Status Access Type Codes

Access Type	Code	Description
Read Type		
R	R	Read
Reset or Default Value		
-n		Value after reset or the default value

9.2.1 ALGO_STATUS Register (Offset = E4h) [Reset = 0000000h]

ALGO_STATUS is shown in Figure 9-4 and described in Table 9-8.

Return to the [Summary Table](#).

Status of various system and algorithm parameters

Figure 9-4. ALGO_STATUS Register

31	30	29	28	27	26	25	24
VOLT_MAG							
R-0h							
23	22	21	20	19	18	17	16
VOLT_MAG							
R-0h							
15	14	13	12	11	10	9	8
DUTY_CMD							
R-0h							
7	6	5	4	3	2	1	0
DUTY_CMD				RESERVED	SYS_ENABLE_FLAG	RESERVED	
R-0h				R-0h	R-0h	R-0h	

Table 9-8. ALGO_STATUS Register Field Descriptions

Bit	Field	Type	Reset	Description
31-16	VOLT_MAG	R	0h	16-bit value indicating the applied modulation index. Modulation index applied = (VOLT_MAG * 100 / 32768)%
15-4	DUTY_CMD	R	0h	12-bit value indicating input duty command in PWM/analog/frequency mode DUTY_CMD (%) = (DUTY_CMD/4095 * 100)%.

Table 9-8. ALGO_STATUS Register Field Descriptions (continued)

Bit	Field	Type	Reset	Description
3	RESERVED	R	0h	Reserved
2	SYS_ENABLE_FLAG	R	0h	1 indicates GUI can control the register 0 indicates GUI is still copying default parameters from shadow memory
1-0	RESERVED	R	0h	Reserved

9.2.2 MTR_PARAMS Register (Offset = E6h) [Reset = 0000000h]

MTR_PARAMS is shown in [Figure 9-5](#) and described in [Table 9-9](#).

Return to the [Summary Table](#).

Status of various motor parameters

Figure 9-5. MTR_PARAMS Register

31	30	29	28	27	26	25	24	23	22	21	20	19	18	17	16
RESERVED								MOTOR_BEMF_CONST							
R-0h								R-0h							
15	14	13	12	11	10	9	8	7	6	5	4	3	2	1	0
RESERVED								RESERVED							
R-0h								R-0h							

Table 9-9. MTR_PARAMS Register Field Descriptions

Bit	Field	Type	Reset	Description
31-24	RESERVED	R	0h	Reserved
23-16	MOTOR_BEMF_CONST	R	0h	8-bit value indicating measured BEMF constant
15-8	RESERVED	R	0h	Reserved
7-0	RESERVED	R	0h	Reserved

9.2.3 ALGO_STATUS_MPET Register (Offset = E8h) [Reset = 0000000h]

ALGO_STATUS_MPET is shown in [Figure 9-6](#) and described in [Table 9-10](#).

Return to the [Summary Table](#).

Status of various MPET parameters

Figure 9-6. ALGO_STATUS_MPET Register

31	30	29	28	27	26	25	24
RESERVED	RESERVED	MPET_KE_STA TUS	MPET_MECH_ STATUS	RESERVED			
R-0h	R-0h	R-0h	R-0h	R-0h			
23	22	21	20	19	18	17	16
RESERVED							
R-0h							
15	14	13	12	11	10	9	8
RESERVED							
R-0h							
7	6	5	4	3	2	1	0
RESERVED							

Figure 9-6. ALGO_STATUS_MPET Register (continued)

R-0h

Table 9-10. ALGO_STATUS_MPET Register Field Descriptions

Bit	Field	Type	Reset	Description
31	RESERVED	R	0h	Reserved
30	RESERVED	R	0h	Reserved
29	MPET_KE_STATUS	R	0h	Indicates status of BEMF constant measurement 0h = Measurement of motor BEMF constant during MPET routine is not completed if BEMF constant measurement is initiated during MPET 1h = Measurement of motor BEMF constant during MPET routine is completed
28	MPET_MECH_STATUS	R	0h	Indicates status of mechanical parameter measurement 0h = Auto Calculation of Speed loop Kp, Ki values during MPET routine is not completed if mechanical parameters measurement(speed loop Kp, Ki values) is initiated during MPET 1h = Auto Calculation of Speed loop Kp, Ki values during MPET routine is completed
27-24	RESERVED	R	0h	Reserved
23-0	RESERVED	R	0h	Reserved

9.3 Algorithm_Control Registers

Table 9-11 lists the memory-mapped registers for the Algorithm_Control registers. All register offset addresses not listed in Table 9-11 should be considered as reserved locations and the register contents should not be modified.

Table 9-11. ALGORITHM_CONTROL Registers

Offset	Acronym	Register Name	Section
ECh	ALGO_DEBUG1	Algorithm Control Register	Section 9.3.1
Eh	ALGO_DEBUG2	Algorithm Control Register	Section 9.3.2
F0h	CURRENT_PI	Current PI Controller used	Section 9.3.3
F2h	SPEED_PI	Speed PI controller used	Section 9.3.4
F4h	DAC_1	DAC1 Control Register	Section 9.3.5
F6h	EEPROM_SECURITY	EEPROM Security Control Register	Section 9.3.6

Complex bit access types are encoded to fit into small table cells. Table 9-12 shows the codes that are used for access types in this section.

Table 9-12. Algorithm_Control Access Type Codes

Access Type	Code	Description
Read Type		
R	R	Read
Write Type		
W	W	Write
Reset or Default Value		
-n		Value after reset or the default value

9.3.1 ALGO_DEBUG1 Register (Offset = ECh) [Reset = 0000000h]

ALGO_DEBUG1 is shown in Figure 9-7 and described in Table 9-13.

Return to the [Summary Table](#).

Algorithm control register for debug

Figure 9-7. ALGO_DEBUG1 Register

31		30		29		28		27		26		25		24	
OVERRIDE		DIGITAL_SPEED_CTRL													
R/W-0h		R/W-0h													
23		22		21		20		19		18		17		16	
DIGITAL_SPEED_CTRL															
R/W-0h															
15		14		13		12		11		10		9		8	
CLOSED_LOO P_DIS	FORCE_ALIGN _EN	RESERVED	FORCE_IPD_E N	FORCE_ISD_E N	RESERVED	RESERVED									
R/W-0h	R/W-0h	R-0h	R/W-0h	R/W-0h	R-0h	R-0h									
7		6		5		4		3		2		1		0	
RESERVED															
R-0h															

Table 9-13. ALGO_DEBUG1 Register Field Descriptions

Bit	Field	Type	Reset	Description
31	OVERRIDE	R/W	0h	Use to control the reference input mode. If OVERRIDE = 0x1, reference command can be written by the user through I2C interface irrespective of SPEED_MODE setting. 0h = Reference input mode based on SPEED_MODE 1h = Reference input mode is Register override mode by using DIGITAL_SPEED_CTRL
30-16	DIGITAL_SPEED_CTRL	R/W	0h	Reference input when OVERRIDE is set 0x1 or SPEED_MODE is set to 0x2. Reference input = (DIGITAL_SPEED_CTRL/32768 *100)%
15	CLOSED_LOOP_DIS	R/W	0h	Use to disable closed loop 0h = Enable Closed Loop 1h = Disable Closed loop, motor commutation in open loop
14	FORCE_ALIGN_EN	R/W	0h	Force align state enable 0h = Disable Force Align state, device comes out of align state if MTR_STARTUP is selected as ALIGN or DOUBLE ALIGN 1h = Enable Force Align state, device stays in align state if MTR_STARTUP is selected as ALIGN or DOUBLE ALIGN
13	RESERVED	R	0h	Reserved
12	FORCE_IPD_EN	R/W	0h	Force IPD enable 0h = Disable Force IPD state, device comes out of IPD state if MTR_STARTUP is selected as IPD 1h = Enable Force IPD state, device stays in IPD state if MTR_STARTUP is selected as IPD
11	FORCE_ISD_EN	R/W	0h	Force ISD enable 0h = Disable Force ISD state, device comes out of ISD state if ISD_EN is set 1h = Enable Force ISD state, device stays in ISD state if ISD_EN is set
10	RESERVED	R	0h	Reserved
9-0	RESERVED	R	0h	Reserved

9.3.2 ALGO_DEBUG2 Register (Offset = EEh) [Reset = 0000000h]

ALGO_DEBUG2 is shown in [Figure 9-8](#) and described in [Table 9-14](#).

Return to the [Summary Table](#).

Algorithm control register for debug

Figure 9-8. ALGO_DEBUG2 Register

31	30	29	28	27	26	25	24
RESERVED	RESERVED			RESERVED	CURRENT_LO OP_DIS	FORCE_VD_CURRENT_LOOP_ DIS	
R-0h	R-0h			R-0h	R/W-0h	R/W-0h	
23	22	21	20	19	18	17	16
FORCE_VD_CURRENT_LOOP_DIS							
R/W-0h							
15	14	13	12	11	10	9	8
FORCE_VQ_CURRENT_LOOP_DIS							
R/W-0h							
7	6	5	4	3	2	1	0
FORCE_VQ_CURRENT_LOOP_ DIS	MPET_CMD	RESERVED	RESERVED	MPET_KE	MPET_MECH	MPET_WRITE_ SHADOW	
R/W-0h	R/W-0h	R-0h	R-0h	R/W-0h	R/W-0h	R/W-0h	

Figure 9-8. ALGO_DEBUG2 Register (continued)

Table 9-14. ALGO_DEBUG2 Register Field Descriptions

Bit	Field	Type	Reset	Description
31	RESERVED	R	0h	Reserved
30-28	RESERVED	R	0h	Reserved
27	RESERVED	R	0h	Reserved
26	CURRENT_LOOP_DIS	R/W	0h	Use to control FORCE_VD_CURRENT_LOOP_DIS and FORCE_VQ_CURRENT_LOOP_DIS. If CURRENT_LOOP_DIS = '1', Current loop and speed loop are disabled 0h = Enable Current Loop 1h = Disable Current Loop
25-16	FORCE_VD_CURRENT_LOOP_DIS	R/W	0h	Sets Vd when current loop and speed loop are disabled If CURRENT_LOOP_DIS = 0b1, then Vd is control using FORCE_VD_CURRENT_LOOP_DIS $mdRef = (FORCE_VD_CURRENT_LOOP_DIS / 500)$ if $FORCE_VD_CURRENT_LOOP_DIS < 500$ $(FORCE_VD_CURRENT_LOOP_DIS - 1024) / 500$ if $FORCE_VD_CURRENT_LOOP_DIS > 524$ Valid values: 0 to 500 and 524 to 1024
15-6	FORCE_VQ_CURRENT_LOOP_DIS	R/W	0h	Sets Vq when current loop and speed loop are disabled If CURRENT_LOOP_DIS = 0b1, then Vq is control using FORCE_VQ_CURRENT_LOOP_DIS $mqRef = (FORCE_VQ_CURRENT_LOOP_DIS / 500)$ if $FORCE_VQ_CURRENT_LOOP_DIS < 500$ $(FORCE_VQ_CURRENT_LOOP_DIS - 1024) / 500$ if $FORCE_VQ_CURRENT_LOOP_DIS > 524$ Valid values: 0 to 500 and 524 to 1024
5	MPET_CMD	R/W	0h	Initiates motor parameter measurement routine when set to 1
4	RESERVED	R	0h	Reserved
3	RESERVED	R	0h	Reserved
2	MPET_KE	R/W	0h	Enables motor BEMF constant measurement during motor parameter measurement routine 0h = Disables Motor BEMF constant measurement during motor parameter measurement routine 1h = Enable Motor BEMF constant measurement during motor parameter measurement routine
1	MPET_MECH	R/W	0h	Enables motor mechanical parameter measurement during motor parameter measurement routine 0h = Disables Motor mechanical parameter measurement during motor parameter measurement routine 1h = Enable Motor mechanical parameter measurement during motor parameter measurement routine
0	MPET_WRITE_SHADOW	R/W	0h	Write measured parameters to shadow register when set to 0x1

9.3.3 CURRENT_PI Register (Offset = F0h) [Reset = 0000000h]

CURRENT_PI is shown in [Figure 9-9](#) and described in [Table 9-15](#).

Return to the [Summary Table](#).

Current PI controller used

Figure 9-9. CURRENT_PI Register

31	30	29	28	27	26	25	24	23	22	21	20	19	18	17	16	15	14	13	12	11	10	9	8	7	6	5	4	3	2	1	0
CURRENT_LOOP_KI																CURRENT_LOOP_KP															
R-0h																R-0h															

Table 9-15. CURRENT_PI Register Field Descriptions

Bit	Field	Type	Reset	Description
31-16	CURRENT_LOOP_KI	R	0h	10 bit value for current loop Ki Same Scaling as CURR_LOOP_KI
15-0	CURRENT_LOOP_KP	R	0h	10 bit value for current loop Kp Same Scaling as CURR_LOOP_KP

9.3.4 SPEED_PI Register (Offset = F2h) [Reset = 0000000h]

SPEED_PI is shown in [Figure 9-10](#) and described in [Table 9-16](#).

Return to the [Summary Table](#).

Speed PI controller used

Figure 9-10. SPEED_PI Register

31	30	29	28	27	26	25	24	23	22	21	20	19	18	17	16	15	14	13	12	11	10	9	8	7	6	5	4	3	2	1	0
SPEED_LOOP_KI																SPEED_LOOP_KP															
R-0h																R-0h															

Table 9-16. SPEED_PI Register Field Descriptions

Bit	Field	Type	Reset	Description
31-16	SPEED_LOOP_KI	R	0h	10 bit value for Speed loop Ki Same Scaling as SPD_LOOP_KI
15-0	SPEED_LOOP_KP	R	0h	10 bit value for Speed loop Kp Same Scaling as SPD_LOOP_KP

9.3.5 DAC_1 Register (Offset = F4h) [Reset = 0000000h]

DAC_1 is shown in [Figure 9-11](#) and described in [Table 9-17](#).

Return to the [Summary Table](#).

DAC1 Control Register

Figure 9-11. DAC_1 Register

31	30	29	28	27	26	25	24	RESERVED									
R-0h																	
23	22	21	20	19	18	17	16	RESERVED				DACOUT1_ENUM_SCALING				DACOUT1_SCALING	
R-0h				R/W-0h								R/W-0h					
15	14	13	12	11	10	9	8	DACOUT1_SCALING				DACOUT1_UNI POLAR		DACOUT1_VAR_ADDR			
R/W-0h				R/W-0h				R/W-0h									
7	6	5	4	3	2	1	0	DACOUT1_VAR_ADDR									
R/W-0h																	

Table 9-17. DAC_1 Register Field Descriptions

Bit	Field	Type	Reset	Description
31-21	RESERVED	R	0h	Reserved

Table 9-17. DAC_1 Register Field Descriptions (continued)

Bit	Field	Type	Reset	Description
20-17	DACOUT1_ENUM_SCALING	R/W	0h	Multiplication factor for DACOUT1 Algorithm variable extracted from the address contained in DACOUT1_VAR_ADDR multiplied with $2^{\text{DACOUT1_ENUM_SCALING}}$. DACOUT1_ENUM_SCALING comes into effect only if DACOUT1_SCALING is 0x0
16-13	DACOUT1_SCALING	R/W	0h	Scaling factor for DACOUT1 Algorithm Variable extracted from the address contained in DACOUT1_VAR_ADDR scaled with DACOUT1_SCALING. Actual voltage depends on DACOUT1_UNIPOLAR. If DACOUT1_UNIPOLAR = 0x1, Actual Value= ((DAC voltage*Per-unit base value))/((3* DACOUT1_SCALING)) If DACOUT1_UNIPOLAR = 0x0, Actual Value= (((DAC voltage-1.5)*Per-unit base value))/((1.5* DACOUT1_SCALING)) Per-unit current base is 0.0375/Rsense (Rsense is current sense resistor in Ohms) A, Per-unit speed base is MAX_SPEED in Hz, Per-unit voltage base for DC Bus voltage is 60V, Per-unit voltage base for phase voltages is 60V/Sqrt(3) Note: For currents recommended DACOUT1_SCALING is 2/8, for voltages 8/8 and for speed information 7/8 0h = Treated as Enum with max value being 31 1h = 1 / 8 2h = 2 / 8 3h = 3 / 8 4h = 4 / 8 5h = 5 / 8 6h = 6 / 8 7h = 7 / 8 8h = 8 / 8 9h = 9 / 8 Ah = 10 / 8 Bh = 11 / 8 Ch = 12 / 8 Dh = 13 / 8 Eh = 14 / 8 Fh = 15 / 8
12	DACOUT1_UNIPOLAR	R/W	0h	Configures output of DACOUT1 If DACOUT2_UNIPOLAR = 0x1, Actual Value= ((DAC2 voltage*Per-unit base value))/((3* DACOUT2_SCALING)) If DACOUT2_UNIPOLAR = 0x0, Actual Value= (((DAC2 voltage-1.5)*Per-unit base value))/((1.5* DACOUT2_SCALING)) Per-unit current base is 0.0375/Rsense (Rsense is current sense resistor in Ohms) A, Per-unit speed base is MAX_SPEED in Hz, Per-unit voltage base for DC Bus voltage is 60V, Per-unit voltage base for phase voltages is 60V/Sqrt(3) Note: For currents recommended DACOUT1_SCALING is 2/8, for voltages 8/8 and for speed information 7/8 0h = Bipolar (Offset of 1.5V) 1h = Unipolar (No Offset)
11-0	DACOUT1_VAR_ADDR	R/W	0h	12-bit address of variable to be monitored

9.3.6 EEPROM_SECURITY Register (Offset = F6h) [Reset = 0000h]

EEPROM_SECURITY is shown in [Figure 9-12](#) and described in [Table 9-18](#).

Return to the [Summary Table](#).

EEPROM Security Control Register

Figure 9-12. EEPROM_SECURITY Register

15	14	13	12	11	10	9	8
RESERVED		USER_EEPROM_KEY					

Figure 9-12. EEPROM_SECURITY Register (continued)

R-0h							R/W-0h
7	6	5	4	3	2	1	0
USER_EEPROM_KEY							
R/W-0h							

Table 9-18. EEPROM_SECURITY Register Field Descriptions

Bit	Field	Type	Reset	Description
15	RESERVED	R	0h	Reserved
14-0	USER_EEPROM_KEY	R/W	0h	User input key to unlock EEPROM for read/writes. Value in EEPROM_LOCK_KEY must be written here for unlocking EEPROM

9.4 Device_Control Registers

Table 9-19 lists the memory-mapped registers for the Device_Control registers. All register offset addresses not listed in Table 9-19 should be considered as reserved locations and the register contents should not be modified.

Table 9-19. DEVICE_CONTROL Registers

Offset	Acronym	Register Name	Section
EAh	ALGO_CTRL1	Device Control Register	Section 9.4.1

Complex bit access types are encoded to fit into small table cells. Table 9-20 shows the codes that are used for access types in this section.

Table 9-20. Device_Control Access Type Codes

Access Type	Code	Description
Read Type		
R	R	Read
Write Type		
W	W	Write
Reset or Default Value		
-n		Value after reset or the default value

9.4.1 ALGO_CTRL1 Register (Offset = EAh) [Reset = 0000000h]

ALGO_CTRL1 is shown in Figure 9-13 and described in Table 9-21.

Return to the [Summary Table](#).

Control settings

Figure 9-13. ALGO_CTRL1 Register

31	30	29	28	27	26	25	24
EEPROM_WRT	EEPROM_READ	CLR_FLT	CLR_FLT_RETRY_COUNT	EEPROM_WRITE_ACCESS_KEY			
R/W-0h	R/W-0h	W-0h	W-0h	R/W-0h			
23	22	21	20	19	18	17	16
EEPROM_WRITE_ACCESS_KEY				RESERVED			
R/W-0h				R-0h			
15	14	13	12	11	10	9	8
RESERVED					WATCHDOG_TICKLE	STL_CMD	STL_KEY
R-0h					W-0h	R/W-0h	R/W-0h
7	6	5	4	3	2	1	0
STL_KEY						RESERVED	
R/W-0h						R-0h	

Table 9-21. ALGO_CTRL1 Register Field Descriptions

Bit	Field	Type	Reset	Description
31	EEPROM_WRT	R/W	0h	Write the configuration from RAM/shadow to EEPROM
30	EEPROM_READ	R/W	0h	Read the default configuration from EEPROM to RAM/shadow
29	CLR_FLT	W	0h	Clears all faults

Table 9-21. ALGO_CTRL1 Register Field Descriptions (continued)

Bit	Field	Type	Reset	Description
28	CLR_FLT_RETRY_COUNT	W	0h	Clears automatic fault retry count
27-20	EEPROM_WRITE_ACCESS_KEY	R/W	0h	EEPROM write access key (0xA5)
19-11	RESERVED	R	0h	Reserved
10	WATCHDOG_TICKLE	W	0h	RAM bit to tickle watchdog in I2C mode. 0x1 should be written to this bit by external controller every EXT_WDT_CFG. Device will reset this bit to 0x0.
9	STL_CMD	R/W	0h	Command to initiate self test (applicable to MCF8329HSULIREER only)
8-1	STL_KEY	R/W	0h	Key(0xBE) to initiate self test on demand (applicable to MCF8329HSULIREER only)
0	RESERVED	R	0h	Reserved

9.5 Algorithm_Variables Registers

Table 9-22 lists the memory-mapped registers for the Algorithm_Variables registers. All register offset addresses not listed in Table 9-22 should be considered as reserved locations and the register contents should not be modified.

Table 9-22. ALGORITHM_VARIABLES Registers

Offset	Acronym	Register Name	Section
18Ch	ALGORITHM_STATE	Current Algorithm State Register	Section 9.5.1
190h	FG_SPEED_FDBK	FG Speed Feedback Register	Section 9.5.2
192h	HALL_SPEED_FDBK	Hall Input Speed Feedback Register	Section 9.5.3
42Eh	BUS_CURRENT	Calculated DC Bus Current Register	Section 9.5.4
460h	PHASE_CURRENT_A	Measured Current on Phase A Register	Section 9.5.5
462h	PHASE_CURRENT_B	Measured Current on Phase B Register	Section 9.5.6
464h	PHASE_CURRENT_C	Measured Current on Phase C Register	Section 9.5.7
479h	CSA_GAIN_FEEDBACK	CSA Gain Register	Section 9.5.8
47Dh	VOLTAGE_GAIN_FEEDBACK	Voltage Gain Register	Section 9.5.9
482h	PVDD_VOLTAGE	PVDD Voltage Register	Section 9.5.10
48Ah	PHASE_VOLTAGE_VA	Phase A Voltage Register	Section 9.5.11
48Ch	PHASE_VOLTAGE_VB	Phase B Voltage Register	Section 9.5.12
48Eh	PHASE_VOLTAGE_VC	Phase C Voltage Register	Section 9.5.13
4D8h	SIN_COMMUTATION_ANGLE	Sine of Commutation Angle	Section 9.5.14
4DAh	COS_COMMUTATION_ANGLE	Cosine of Commutation Angle	Section 9.5.15
504h	IALPHA	IALPHA Current Register	Section 9.5.16
506h	IBETA	IBETA Current Register	Section 9.5.17
508h	VALPHA	VALPHA Voltage Register	Section 9.5.18
50Ah	VBETA	VBETA Voltage Register	Section 9.5.19
514h	ID	Measured d-axis Current Register	Section 9.5.20
516h	IQ	Measured q-axis Current Register	Section 9.5.21
518h	VD	VD Voltage Register	Section 9.5.22
51Ah	VQ	VQ Voltage Register	Section 9.5.23
54Ch	IQ_REF_ROTOR_ALIGN	Align Current Reference	Section 9.5.24
560h	SPEED_REF_OPEN_LOOP	Open Loop Speed Register	Section 9.5.25
56Eh	IQ_REF_OPEN_LOOP	Open Loop Current Reference	Section 9.5.26
5EEh	SPEED_REF_CLOSED_LOOP	Speed Reference Register	Section 9.5.27
628h	POWER_FEED_BACK	Power Feedback	Section 9.5.28
630h	ID_REF_CLOSED_LOOP	Reference for d-axis Current loop Register	Section 9.5.29
632h	IQ_REF_CLOSED_LOOP	Reference q-axis for Current loop Register	Section 9.5.30
6F0h	ISD_STATE	ISD State Register	Section 9.5.31
6FAh	ISD_SPEED	ISD Speed Register	Section 9.5.32
724h	IPD_STATE	IPD State Register	Section 9.5.33
746h	IPD_ANGLE	Calculated IPD Angle Register	Section 9.5.34
772h	ED	Estimated BEMF EQ Register	Section 9.5.35
774h	EQ	Estimated BEMF ED Register	Section 9.5.36
784h	SPEED_FDBK	Speed Feedback Register	Section 9.5.37
788h	THETA_EST	Estimated rotor Position Register	Section 9.5.38

Complex bit access types are encoded to fit into small table cells. [Table 9-23](#) shows the codes that are used for access types in this section.

Table 9-23. Algorithm_Variables Access Type Codes

Access Type	Code	Description
Read Type		
R	R	Read
Reset or Default Value		
-n		Value after reset or the default value

9.5.1 ALGORITHM_STATE Register (Offset = 18Ch) [Reset = 0000h]

ALGORITHM_STATE is shown in [Figure 9-14](#) and described in [Table 9-24](#).

Return to the [Summary Table](#).

Current Algorithm State Register

Figure 9-14. ALGORITHM_STATE Register

15	14	13	12	11	10	9	8
ALGORITHM_STATE							
R-0h							
7	6	5	4	3	2	1	0
ALGORITHM_STATE							
R-0h							

Table 9-24. ALGORITHM_STATE Register Field Descriptions

Bit	Field	Type	Reset	Description
15-0	ALGORITHM_STATE	R	0h	16-bit value indicating current state of device 00h = MOTOR_IDLE 01h = MOTOR_ISD 02h = MOTOR_TRISTATE 03h = MOTOR_BRAKE_ON_START 04h = MOTOR_IPD 05h = MOTOR_SLOW_FIRST_CYCLE 06h = MOTOR_ALIGN 07h = MOTOR_OPEN_LOOP 08h = MOTOR_CLOSED_LOOP_UNALIGNED 09h = MOTOR_CLOSED_LOOP_ALIGNED 0Ah = MOTOR_CLOSED_LOOP_ACTIVE_BRAKING 0Bh = MOTOR_SOFT_STOP 0Ch = RESEREVED 0Dh = MOTOR_BRAKE_ON_STOP 0Eh = MOTOR_FAULT 0Fh = MOTOR_MPET_MOTOR_STOP_CHECK 10h = MOTOR_MPET_MOTOR_STOP_WAIT 11h = MOTOR_MPET_MOTOR_BRAKE 12h = MOTOR_MPET_ALGORITHM_PARAMETERS_INIT 13h = RESEREVED 14h = MOTOR_MPET_KE_MEASURE 15h = MOTOR_MPET_STALL_CURRENT_MEASURE 16h = MOTOR_MPET_TORQUE_MODE 17h = MOTOR_MPET_DONE 18h = MOTOR_MPET_FAULT

9.5.2 FG_SPEED_FDBK Register (Offset = 190h) [Reset = 0000000h]

FG_SPEED_FDBK is shown in [Figure 9-15](#) and described in [Table 9-25](#).

Return to the [Summary Table](#).

Speed Feedback from FG

Figure 9-15. FG_SPEED_FDBK Register

31	30	29	28	27	26	25	24	23	22	21	20	19	18	17	16	15	14	13	12	11	10	9	8	7	6	5	4	3	2	1	0
FG_SPEED_FDBK																															
R-0h																															

Table 9-25. FG_SPEED_FDBK Register Field Descriptions

Bit	Field	Type	Reset	Description
31-0	FG_SPEED_FDBK	R	0h	32-bit value indicating absolute (unsigned) value of estimated motor speed based on FG Estimated motor speed (in Hz) = (FG_SPEED_FDBK / 2 ²⁷) * MAX_SPEED (in Hz)

9.5.3 HALL_SPEED_FDBK Register (Offset = 192h) [Reset = 0000000h]

HALL_SPEED_FDBK is shown in [Figure 9-16](#) and described in [Table 9-26](#).

Return to the [Summary Table](#).

Speed Feedback based on Hall Input

Figure 9-16. HALL_SPEED_FDBK Register

31	30	29	28	27	26	25	24	23	22	21	20	19	18	17	16	15	14	13	12	11	10	9	8	7	6	5	4	3	2	1	0
HALL_SPEED_FDBK																															
R-0h																															

Table 9-26. HALL_SPEED_FDBK Register Field Descriptions

Bit	Field	Type	Reset	Description
31-0	HALL_SPEED_FDBK	R	0h	32-bit value indicating absolute (unsigned) value of estimated motor speed based on Hall Input Estimated motor speed (in Hz) = (HALL_SPEED_FDBK / 2 ²⁷) * MAX_SPEED (in Hz)

9.5.4 BUS_CURRENT Register (Offset = 42Eh) [Reset = 0000000h]

BUS_CURRENT is shown in [Figure 9-17](#) and described in [Table 9-27](#).

Return to the [Summary Table](#).

Calculated Supply Current Register

Figure 9-17. BUS_CURRENT Register

31	30	29	28	27	26	25	24	23	22	21	20	19	18	17	16	15	14	13	12	11	10	9	8	7	6	5	4	3	2	1	0
BUS_CURRENT																															
R-0h																															

Table 9-27. BUS_CURRENT Register Field Descriptions

Bit	Field	Type	Reset	Description
31-0	BUS_CURRENT	R	0h	32-bit signed value indicating DC bus current. Negative value represented in two's complement DC bus current (in Amps) = (BUS_CURRENT / 2 ²⁷) * Per-unit current base Per-unit current base is 0.0375/Rsense (Rsense is current sense resistor in Ohms) A

9.5.5 PHASE_CURRENT_A Register (Offset = 460h) [Reset = 0000000h]

PHASE_CURRENT_A is shown in [Figure 9-18](#) and described in [Table 9-28](#).

Return to the [Summary Table](#).

Measured current on Phase A Register

Figure 9-18. PHASE_CURRENT_A Register

31	30	29	28	27	26	25	24	23	22	21	20	19	18	17	16	15	14	13	12	11	10	9	8	7	6	5	4	3	2	1	0
PHASE_CURRENT_A																															
R-0h																															

Table 9-28. PHASE_CURRENT_A Register Field Descriptions

Bit	Field	Type	Reset	Description
31-0	PHASE_CURRENT_A	R	0h	32-bit signed value indicating measured continuous Phase A current. Negative value represented in two's complement Phase A current (in Amps) = (PHASE_CURRENT_A / 2 ²⁷) * Per-unit current base Per-unit current base is 0.0375/Rsense (Rsense is current sense resistor in Ohms) A

9.5.6 PHASE_CURRENT_B Register (Offset = 462h) [Reset = 0000000h]

PHASE_CURRENT_B is shown in [Figure 9-19](#) and described in [Table 9-29](#).

Return to the [Summary Table](#).

Measured current on Phase B Register

Figure 9-19. PHASE_CURRENT_B Register

31	30	29	28	27	26	25	24	23	22	21	20	19	18	17	16	15	14	13	12	11	10	9	8	7	6	5	4	3	2	1	0
PHASE_CURRENT_B																															
R-0h																															

Table 9-29. PHASE_CURRENT_B Register Field Descriptions

Bit	Field	Type	Reset	Description
31-0	PHASE_CURRENT_B	R	0h	32-bit signed value indicating measured continuous Phase B current. Negative value represented in two's complement Phase B current (in Amps) = (PHASE_CURRENT_B / 2 ²⁷) * Per-unit current base Per-unit current base is 0.0375/Rsense (Rsense is current sense resistor in Ohms) A

9.5.7 PHASE_CURRENT_C Register (Offset = 464h) [Reset = 0000000h]

PHASE_CURRENT_C is shown in [Figure 9-20](#) and described in [Table 9-30](#).

Return to the [Summary Table](#).

Measured current on Phase C Register

Figure 9-20. PHASE_CURRENT_C Register

31	30	29	28	27	26	25	24	23	22	21	20	19	18	17	16	15	14	13	12	11	10	9	8	7	6	5	4	3	2	1	0
PHASE_CURRENT_C																															
R-0h																															

Table 9-30. PHASE_CURRENT_C Register Field Descriptions

Bit	Field	Type	Reset	Description
31-0	PHASE_CURRENT_C	R	0h	32-bit signed value indicating measured continuous Phase C current. Negative value represented in two's complement Phase C current (in Amps) = (PHASE_CURRENT_C / 2 ²⁷) * Per-unit current base Per-unit current base is 0.0375/Rsense (Rsense is current sense resistor in Ohms) A

9.5.8 CSA_GAIN_FEEDBACK Register (Offset = 479h) [Reset = 0000h]

CSA_GAIN_FEEDBACK is shown in [Figure 9-21](#) and described in [Table 9-31](#).

Return to the [Summary Table](#).

CSA Gain Register

Figure 9-21. CSA_GAIN_FEEDBACK Register

15	14	13	12	11	10	9	8
CSA_GAIN_FEEDBACK							
R-0h							
7	6	5	4	3	2	1	0
CSA_GAIN_FEEDBACK							
R-0h							

Table 9-31. CSA_GAIN_FEEDBACK Register Field Descriptions

Bit	Field	Type	Reset	Description
15-0	CSA_GAIN_FEEDBACK	R	0h	16-bit value indicating the current sense gain 0h = 40V/V 1h = 20V/V 2h = 10V/V 3h = 5V/V

9.5.9 VOLTAGE_GAIN_FEEDBACK Register (Offset = 47Dh) [Reset = 0000h]

VOLTAGE_GAIN_FEEDBACK is shown in [Figure 9-22](#) and described in [Table 9-32](#).

Return to the [Summary Table](#).

Voltage Gain Register

Figure 9-22. VOLTAGE_GAIN_FEEDBACK Register

15	14	13	12	11	10	9	8
VOLTAGE_GAIN_FEEDBACK							
R-0h							
7	6	5	4	3	2	1	0

Figure 9-22. VOLTAGE_GAIN_FEEDBACK Register (continued)

VOLTAGE_GAIN_FEEDBACK
R-0h

Table 9-32. VOLTAGE_GAIN_FEEDBACK Register Field Descriptions

Bit	Field	Type	Reset	Description
15-0	VOLTAGE_GAIN_FEEDBACK	R	0h	16-bit value indicating the voltage gain 0h = 60V 1h = 30V 2h = 15V

9.5.10 PVDD_VOLTAGE Register (Offset = 482h) [Reset = 0000000h]

PVDD_VOLTAGE is shown in [Figure 9-23](#) and described in [Table 9-33](#).

Return to the [Summary Table](#).

Supply voltage register

Figure 9-23. PVDD_VOLTAGE Register

31 30 29 28 27 26 25 24 23 22 21 20 19 18 17 16 15 14 13 12 11 10 9 8 7 6 5 4 3 2 1 0
PVDD_VOLTAGE
R-0h

Table 9-33. PVDD_VOLTAGE Register Field Descriptions

Bit	Field	Type	Reset	Description
31-0	PVDD_VOLTAGE	R	0h	32-bit value indicating PVDD voltage DC Bus Voltage (in Volts) = PVDD_VOLTAGE * 60 / 2 ²⁷

9.5.11 PHASE_VOLTAGE_VA Register (Offset = 48Ah) [Reset = 0000000h]

PHASE_VOLTAGE_VA is shown in [Figure 9-24](#) and described in [Table 9-34](#).

Return to the [Summary Table](#).

Phase A Voltage Register

Figure 9-24. PHASE_VOLTAGE_VA Register

31 30 29 28 27 26 25 24 23 22 21 20 19 18 17 16 15 14 13 12 11 10 9 8 7 6 5 4 3 2 1 0
PHASE_VOLTAGE_VA
R-0h

Table 9-34. PHASE_VOLTAGE_VA Register Field Descriptions

Bit	Field	Type	Reset	Description
31-0	PHASE_VOLTAGE_VA	R	0h	32-bit signed value indicating measured A phase voltage during ISD. Negative value represented in two's complement Phase A voltage (in Volts) = PHASE_VOLTAGE_VA * 60 / (sqrt(3) * 2 ²⁷)

9.5.12 PHASE_VOLTAGE_VB Register (Offset = 48Ch) [Reset = 0000000h]

PHASE_VOLTAGE_VB is shown in [Figure 9-25](#) and described in [Table 9-35](#).

Return to the [Summary Table](#).

Phase B Voltage Register

Figure 9-25. PHASE_VOLTAGE_VB Register

31	30	29	28	27	26	25	24	23	22	21	20	19	18	17	16	15	14	13	12	11	10	9	8	7	6	5	4	3	2	1	0
PHASE_VOLTAGE_VB																															
R-0h																															

Table 9-35. PHASE_VOLTAGE_VB Register Field Descriptions

Bit	Field	Type	Reset	Description
31-0	PHASE_VOLTAGE_VB	R	0h	32-bit signed value indicating measured B phase voltage during ISD. Negative value represented in two's complement. Phase B voltage (in Volts) = PHASE_VOLTAGE_VB * 60 / (sqrt(3) * 2 ²⁷)

9.5.13 PHASE_VOLTAGE_VC Register (Offset = 48Eh) [Reset = 0000000h]

PHASE_VOLTAGE_VC is shown in [Figure 9-26](#) and described in [Table 9-36](#).

Return to the [Summary Table](#).

Phase C Voltage Register

Figure 9-26. PHASE_VOLTAGE_VC Register

31	30	29	28	27	26	25	24	23	22	21	20	19	18	17	16	15	14	13	12	11	10	9	8	7	6	5	4	3	2	1	0
PHASE_VOLTAGE_VC																															
R-0h																															

Table 9-36. PHASE_VOLTAGE_VC Register Field Descriptions

Bit	Field	Type	Reset	Description
31-0	PHASE_VOLTAGE_VC	R	0h	32-bit signed value indicating measured C phase voltage during ISD. Negative value represented in two's complement Phase C voltage (in Volts) = PHASE_VOLTAGE_VC * 60 / (sqrt(3) * 2 ²⁷)

9.5.14 SIN_COMMUTATION_ANGLE Register (Offset = 4D8h) [Reset = 0000000h]

SIN_COMMUTATION_ANGLE is shown in [Figure 9-27](#) and described in [Table 9-37](#).

Return to the [Summary Table](#).

Sine of Commutation Angle

Figure 9-27. SIN_COMMUTATION_ANGLE Register

31	30	29	28	27	26	25	24	23	22	21	20	19	18	17	16	15	14	13	12	11	10	9	8	7	6	5	4	3	2	1	0
SIN_COMMUTATION_ANGLE																															
R-0h																															

Table 9-37. SIN_COMMUTATION_ANGLE Register Field Descriptions

Bit	Field	Type	Reset	Description
31-0	SIN_COMMUTATION_ANGLE	R	0h	32-bit signed value indicating sine of rotor Angle. Negative value represented in two's complement $\sin(\text{rotor angle}) = (\text{SIN_COMMUTATION_ANGLE} / 2^{27})$

9.5.15 COS_COMMUTATION_ANGLE Register (Offset = 4DAh) [Reset = 0000000h]

COS_COMMUTATION_ANGLE is shown in [Figure 9-28](#) and described in [Table 9-38](#).

Return to the [Summary Table](#).

Cosine of Commutation Angle

Figure 9-28. COS_COMMUTATION_ANGLE Register

31	30	29	28	27	26	25	24	23	22	21	20	19	18	17	16	15	14	13	12	11	10	9	8	7	6	5	4	3	2	1	0
COS_COMMUTATION_ANGLE																															
R-0h																															

Table 9-38. COS_COMMUTATION_ANGLE Register Field Descriptions

Bit	Field	Type	Reset	Description
31-0	COS_COMMUTATION_ANGLE	R	0h	32-bit signed value indicating cosine of rotor angle. Negative value represented in two's complement $\cos(\text{rotor angle}) = (\text{COS_COMMUTATION_ANGLE} / 2^{27})$

9.5.16 IALPHA Register (Offset = 504h) [Reset = 0000000h]

IALPHA is shown in [Figure 9-29](#) and described in [Table 9-39](#).

Return to the [Summary Table](#).

IALPHA Current Register

Figure 9-29. IALPHA Register

31	30	29	28	27	26	25	24	23	22	21	20	19	18	17	16	15	14	13	12	11	10	9	8	7	6	5	4	3	2	1	0
IALPHA																															
R-0h																															

Table 9-39. IALPHA Register Field Descriptions

Bit	Field	Type	Reset	Description
31-0	IALPHA	R	0h	32-bit signed value indicating phase current in alpha- beta domain. Negative value represented in two's complement $I_{\text{Alpha}} (\text{in Amps}) = (\text{IALPHA} / 2^{27}) * \text{Per-unit current base}$ Per-unit current base is 0.0375/Rsense (Rsense is current sense resistor in Ohms) A

9.5.17 IBETA Register (Offset = 506h) [Reset = 0000000h]

IBETA is shown in [Figure 9-30](#) and described in [Table 9-40](#).

Return to the [Summary Table](#).

IBETA Current Register

Figure 9-30. IBETA Register

31	30	29	28	27	26	25	24	23	22	21	20	19	18	17	16	15	14	13	12	11	10	9	8	7	6	5	4	3	2	1	0
IBETA																															
R-0h																															

Table 9-40. IBETA Register Field Descriptions

Bit	Field	Type	Reset	Description
31-0	IBETA	R	0h	32-bit signed value indicating phase current in alpha- beta domain. Negative value represented in two's complement $I_{\text{Beta}} (\text{in Amps}) = (\text{IBETA} / 2^{27}) * \text{Per-unit current base}$ Per-unit current base is 0.0375/Rsense (Rsense is current sense resistor in Ohms) A

9.5.18 VALPHA Register (Offset = 508h) [Reset = 0000000h]

VALPHA is shown in [Figure 9-31](#) and described in [Table 9-41](#).

Return to the [Summary Table](#).

VALPHA Voltage Register

Figure 9-31. VALPHA Register

31	30	29	28	27	26	25	24	23	22	21	20	19	18	17	16	15	14	13	12	11	10	9	8	7	6	5	4	3	2	1	0
VALPHA																															
R-0h																															

Table 9-41. VALPHA Register Field Descriptions

Bit	Field	Type	Reset	Description
31-0	VALPHA	R	0h	32-bit signed value indicating applied phase voltage in alpha-beta domain $V_{Alpha} \text{ (in Volts)} = (VALPHA / 2^{27}) * 60 / \text{sqrt}(3)$

9.5.19 VBETA Register (Offset = 50Ah) [Reset = 0000000h]

VBETA is shown in [Figure 9-32](#) and described in [Table 9-42](#).

Return to the [Summary Table](#).

VBETA Voltage Register

Figure 9-32. VBETA Register

31	30	29	28	27	26	25	24	23	22	21	20	19	18	17	16	15	14	13	12	11	10	9	8	7	6	5	4	3	2	1	0
VBETA																															
R-0h																															

Table 9-42. VBETA Register Field Descriptions

Bit	Field	Type	Reset	Description
31-0	VBETA	R	0h	32-bit signed value indicating applied phase voltage in alpha-beta domain. Negative value represented in two's complement $V_{Beta} \text{ (in Volts)} = (VBETA / 2^{27}) * 60 / \text{sqrt}(3)$

9.5.20 ID Register (Offset = 514h) [Reset = 0000000h]

ID is shown in [Figure 9-33](#) and described in [Table 9-43](#).

Return to the [Summary Table](#).

Measured d-axis Current Register

Figure 9-33. ID Register

31	30	29	28	27	26	25	24	23	22	21	20	19	18	17	16	15	14	13	12	11	10	9	8	7	6	5	4	3	2	1	0
ID																															
R-0h																															

Table 9-43. ID Register Field Descriptions

Bit	Field	Type	Reset	Description
31-0	ID	R	0h	32-bit signed value indicating d-axis(flux component) phase current in d-q domain. Negative value represented in two's complement Flux component phase current (in Amps) = $(ID / 2^{27}) * \text{Per-unit current base}$ Per-unit current base is 0.0375/Rsense (Rsense is current sense resistor in Ohms) A

9.5.21 IQ Register (Offset = 516h) [Reset = 0000000h]

IQ is shown in [Figure 9-34](#) and described in [Table 9-44](#).

Return to the [Summary Table](#).

Measured q-axis Current Register

Figure 9-34. IQ Register

31	30	29	28	27	26	25	24	23	22	21	20	19	18	17	16	15	14	13	12	11	10	9	8	7	6	5	4	3	2	1	0
IQ																															
R-0h																															

Table 9-44. IQ Register Field Descriptions

Bit	Field	Type	Reset	Description
31-0	IQ	R	0h	32-bit signed value indicating q-axis(torque component) phase current in d-q domain. Negative value represented in two's complement Torque component phase current (in Amps) = $(IQ / 2^{27}) * \text{Per-unit current base}$ Per-unit current base is 0.0375/Rsense (Rsense is current sense resistor in Ohms) A

9.5.22 VD Register (Offset = 518h) [Reset = 0000000h]

VD is shown in [Figure 9-35](#) and described in [Table 9-45](#).

Return to the [Summary Table](#).

VD Voltage Register

Figure 9-35. VD Register

31	30	29	28	27	26	25	24	23	22	21	20	19	18	17	16	15	14	13	12	11	10	9	8	7	6	5	4	3	2	1	0
VD																															
R-0h																															

Table 9-45. VD Register Field Descriptions

Bit	Field	Type	Reset	Description
31-0	VD	R	0h	32-bit signed value indicating applied phase voltage in d-q domain. Negative value represented in two's complement V_d (in Volts) = $(VD / 2^{27}) * 60 / \text{sqrt}(3)$

9.5.23 VQ Register (Offset = 51Ah) [Reset = 0000000h]

VQ is shown in [Figure 9-36](#) and described in [Table 9-46](#).

Return to the [Summary Table](#).

VQ Voltage Register

Figure 9-36. VQ Register

31	30	29	28	27	26	25	24	23	22	21	20	19	18	17	16	15	14	13	12	11	10	9	8	7	6	5	4	3	2	1	0
VQ																															
R-0h																															

Table 9-46. VQ Register Field Descriptions

Bit	Field	Type	Reset	Description
31-0	VQ	R	0h	32-bit signed value indicating applied phase voltage in d-q domain. Negative value represented in two's complement Vq (in Volts) = (VQ / 2 ²⁷) * 60 / sqrt(3)

9.5.24 IQ_REF_ROTATOR_ALIGN Register (Offset = 54Ch) [Reset = 00000000h]

IQ_REF_ROTATOR_ALIGN is shown in Figure 9-37 and described in Table 9-47.

Return to the [Summary Table](#).

Align Current Reference

Figure 9-37. IQ_REF_ROTATOR_ALIGN Register

31	30	29	28	27	26	25	24	23	22	21	20	19	18	17	16	15	14	13	12	11	10	9	8	7	6	5	4	3	2	1	0
IQ_REF_ROTATOR_ALIGN																															
R-0h																															

Table 9-47. IQ_REF_ROTATOR_ALIGN Register Field Descriptions

Bit	Field	Type	Reset	Description
31-0	IQ_REF_ROTATOR_ALIGN	R	0h	32-bit signed value indicating current reference during align state. Negative value represented in two's complement Current reference during Align State (in Amps) = (IQ_REF_ROTATOR_ALIGN / 2 ²⁷) * Per-unit current base Per-unit current base is 0.0375/Rsense (Rsense is current sense resistor in Ohms) A

9.5.25 SPEED_REF_OPEN_LOOP Register (Offset = 560h) [Reset = 00000000h]

SPEED_REF_OPEN_LOOP is shown in Figure 9-38 and described in Table 9-48.

Return to the [Summary Table](#).

Speed at which motor transitions to close loop

Figure 9-38. SPEED_REF_OPEN_LOOP Register

31	30	29	28	27	26	25	24	23	22	21	20	19	18	17	16	15	14	13	12	11	10	9	8	7	6	5	4	3	2	1	0
SPEED_REF_OPEN_LOOP																															
R-0h																															

Table 9-48. SPEED_REF_OPEN_LOOP Register Field Descriptions

Bit	Field	Type	Reset	Description
31-0	SPEED_REF_OPEN_LOOP	R	0h	32-bit signed value indicating open loop speed reference. Negative value represented in two's complement Speed reference during Open loop (in Hz) = (SPEED_REF_OPEN_LOOP / 2 ²⁷) * MAX_SPEED (in Hz)

9.5.26 IQ_REF_OPEN_LOOP Register (Offset = 56Eh) [Reset = 0000000h]

IQ_REF_OPEN_LOOP is shown in [Figure 9-39](#) and described in [Table 9-49](#).

Return to the [Summary Table](#).

Open Loop Current Reference

Figure 9-39. IQ_REF_OPEN_LOOP Register

31	30	29	28	27	26	25	24	23	22	21	20	19	18	17	16	15	14	13	12	11	10	9	8	7	6	5	4	3	2	1	0
IQ_REF_OPEN_LOOP																															
R-0h																															

Table 9-49. IQ_REF_OPEN_LOOP Register Field Descriptions

Bit	Field	Type	Reset	Description
31-0	IQ_REF_OPEN_LOOP	R	0h	32-bit signed value indicating current reference during open loop. Negative value represented in two's complement Current reference during Open loop (in Amps) = $(IQ_REF_OPEN_LOOP / 2^{27}) * \text{Per-unit current base}$ Per-unit current base is 0.0375/Rsense (Rsense is current sense resistor in Ohms) A

9.5.27 SPEED_REF_CLOSED_LOOP Register (Offset = 5EEh) [Reset = 0000000h]

SPEED_REF_CLOSED_LOOP is shown in [Figure 9-40](#) and described in [Table 9-50](#).

Return to the [Summary Table](#).

Speed Reference Register

Figure 9-40. SPEED_REF_CLOSED_LOOP Register

31	30	29	28	27	26	25	24	23	22	21	20	19	18	17	16	15	14	13	12	11	10	9	8	7	6	5	4	3	2	1	0
SPEED_REF_CLOSED_LOOP																															
R-0h																															

Table 9-50. SPEED_REF_CLOSED_LOOP Register Field Descriptions

Bit	Field	Type	Reset	Description
31-0	SPEED_REF_CLOSED_LOOP	R	0h	32-bit signed value indicating reference for closed loop. Negative value represented in two's complement. In speed control mode, speed reference in closed loop (in Hz) = $(SPEED_REF_CLOSED_LOOP / 2^{27}) * MAX_SPEED$ (in Hz). In power mode, power reference in closed loop (in Watts) = $(SPEED_REF_CLOSED_LOOP / 2^{27}) * MAX_POWER$ (in Watts) In current mode, Iq current reference in closed loop (in Amps) = $(SPEED_REF_CLOSED_LOOP / 2^{27}) * ILIMIT$ (in Amps)

9.5.28 POWER_FEED_BACK Register (Offset = 628h) [Reset = 0000000h]

POWER_FEED_BACK is shown in [Figure 9-41](#) and described in [Table 9-51](#).

Return to the [Summary Table](#).

Power Feedback

Figure 9-41. POWER_FEED_BACK Register

31	30	29	28	27	26	25	24	23	22	21	20	19	18	17	16	15	14	13	12	11	10	9	8	7	6	5	4	3	2	1	0
POWER_FEED_BACK																															
R-0h																															

Table 9-51. POWER_FEED_BACK Register Field Descriptions

Bit	Field	Type	Reset	Description
31-0	POWER_FEED_BACK	R	0h	32-bit signed value indicating power consumption. Negative value represented in two's complement Power Consumption (in Watts) = (POWER_FEED_BACK / 2 ²⁷) * Per-unit power base Per-unit power base is (2.25/Rsense (Rsense is current sense resistor in Ohms)) in watts

9.5.29 ID_REF_CLOSED_LOOP Register (Offset = 630h) [Reset = 00000000h]

ID_REF_CLOSED_LOOP is shown in [Figure 9-42](#) and described in [Table 9-52](#).

Return to the [Summary Table](#).

Reference for Current Loop Register

Figure 9-42. ID_REF_CLOSED_LOOP Register

31	30	29	28	27	26	25	24	23	22	21	20	19	18	17	16	15	14	13	12	11	10	9	8	7	6	5	4	3	2	1	0
ID_REF_CLOSED_LOOP																															
R-0h																															

Table 9-52. ID_REF_CLOSED_LOOP Register Field Descriptions

Bit	Field	Type	Reset	Description
31-0	ID_REF_CLOSED_LOOP	R	0h	32-bit signed value indicating d-axis(flux component) phase current reference in closed loop . Negative value represented in two's complement Flux component phase current reference in closed loop (in Amps) = (ID / 2 ²⁷) * Per-unit current base Per-unit current base is 0.0375/Rsense (Rsense is current sense resistor in Ohms) A

9.5.30 IQ_REF_CLOSED_LOOP Register (Offset = 632h) [Reset = 00000000h]

IQ_REF_CLOSED_LOOP is shown in [Figure 9-43](#) and described in [Table 9-53](#).

Return to the [Summary Table](#).

Reference for Current Loop Register

Figure 9-43. IQ_REF_CLOSED_LOOP Register

31	30	29	28	27	26	25	24	23	22	21	20	19	18	17	16	15	14	13	12	11	10	9	8	7	6	5	4	3	2	1	0
IQ_REF_CLOSED_LOOP																															
R-0h																															

Table 9-53. IQ_REF_CLOSED_LOOP Register Field Descriptions

Bit	Field	Type	Reset	Description
31-0	IQ_REF_CLOSED_LOOP	R	0h	32-bit signed value indicating q-axis(torque component) phase current reference in closed loop. Negative value represented in two's complement Torque component phase current reference in closed loop (in Amps) = (IQ / 2 ²⁷) * Per-unit current base Per-unit current base is 0.0375/Rsense (Rsense is current sense resistor in Ohms) A

9.5.31 ISD_STATE Register (Offset = 6F0h) [Reset = 0000h]

 ISD_STATE is shown in [Figure 9-44](#) and described in [Table 9-54](#).

 Return to the [Summary Table](#).

ISD state Register

Figure 9-44. ISD_STATE Register

15	14	13	12	11	10	9	8
ISD_STATE							
R-0h							
7	6	5	4	3	2	1	0
ISD_STATE							
R-0h							

Table 9-54. ISD_STATE Register Field Descriptions

Bit	Field	Type	Reset	Description
15-0	ISD_STATE	R	0h	16-bit value indicating current ISD state 0h = ISD_INIT 1h = ISD_MOTOR_STOP_CHECK 2h = ISD_ESTIM_INIT 3h = ISD_RUN_MOTOR_CHECK 4h = ISD_MOTOR_DIRECTION_CHECK 5h = ISD_COMPLETE 6h = ISD_FAULT

9.5.32 ISD_SPEED Register (Offset = 6FAh) [Reset = 0000000h]

 ISD_SPEED is shown in [Figure 9-45](#) and described in [Table 9-55](#).

 Return to the [Summary Table](#).

ISD Speed Register

Figure 9-45. ISD_SPEED Register

31	30	29	28	27	26	25	24	23	22	21	20	19	18	17	16	15	14	13	12	11	10	9	8	7	6	5	4	3	2	1	0
ISD_SPEED																															
R-0h																															

Table 9-55. ISD_SPEED Register Field Descriptions

Bit	Field	Type	Reset	Description
31-0	ISD_SPEED	R	0h	32-bit value indicating calculated absolute speed during ISD state Speed estimated during ISD (in Hz) = (ISD_SPEED / 2 ²⁷) * MAX_SPEED (in Hz)

9.5.33 IPD_STATE Register (Offset = 724h) [Reset = 0000h]

 IPD_STATE is shown in [Figure 9-46](#) and described in [Table 9-56](#).

 Return to the [Summary Table](#).

IPD state Register

Figure 9-46. IPD_STATE Register

15	14	13	12	11	10	9	8
IPD_STATE							

Figure 9-46. IPD_STATE Register (continued)

R-0h							
7	6	5	4	3	2	1	0
IPD_STATE							
R-0h							

Table 9-56. IPD_STATE Register Field Descriptions

Bit	Field	Type	Reset	Description
15-0	IPD_STATE	R	0h	16-bit value indicating current IPD state 0h = IPD_INIT 1h = IPD_VECTOR_CONFIG 2h = IPD_RUN 3h = IPD_SLOW_RISE_CLOCK 4h = IPD_SLOW_FALL_CLOCK 5h = IPD_WAIT_CURRENT_DECAY 6h = IPD_GET_TIMES 7h = IPD_SET_NEXT_VECTOR 8h = IPD_CALC_SECTOR_RISE 9h = IPD_CALC_ROTOR_POSITION Ah = IPD_CALC_ANGLE Bh = IPD_COMPLETE Ch = IPD_FAULT

9.5.34 IPD_ANGLE Register (Offset = 746h) [Reset = 00000000h]

IPD_ANGLE is shown in [Figure 9-47](#) and described in [Table 9-57](#).

Return to the [Summary Table](#).

Calculated IPD Angle Register

Figure 9-47. IPD_ANGLE Register

31	30	29	28	27	26	25	24	23	22	21	20	19	18	17	16	15	14	13	12	11	10	9	8	7	6	5	4	3	2	1	0
IPD_ANGLE																															
R-0h																															

Table 9-57. IPD_ANGLE Register Field Descriptions

Bit	Field	Type	Reset	Description
31-0	IPD_ANGLE	R	0h	32-bit signed value indicating measured IPD angle. Negative value represented in two's complement IPD Angle (in degrees) = (IPD_ANGLE / 2 ²⁷) * 360

9.5.35 ED Register (Offset = 772h) [Reset = 00000000h]

ED is shown in [Figure 9-48](#) and described in [Table 9-58](#).

Return to the [Summary Table](#).

Estimated BEMF EQ Register

Figure 9-48. ED Register

31	30	29	28	27	26	25	24	23	22	21	20	19	18	17	16	15	14	13	12	11	10	9	8	7	6	5	4	3	2	1	0
ED																															
R-0h																															

Table 9-58. ED Register Field Descriptions

Bit	Field	Type	Reset	Description
31-0	ED	R	0h	32-bit signed value indicating estimated Back EMF along the D-Axis (Ed). Negative value represented in two's complement Ed (in Volts) = (ED / 2 ²⁷) * 60 / sqrt(3)

9.5.36 EQ Register (Offset = 774h) [Reset = 0000000h]

EQ is shown in [Figure 9-49](#) and described in [Table 9-59](#).

Return to the [Summary Table](#).

Estimated BEMF ED Register

Figure 9-49. EQ Register

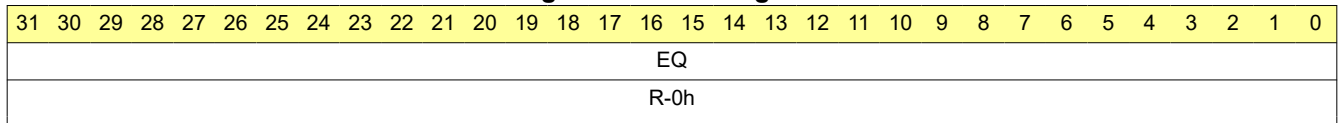

Table 9-59. EQ Register Field Descriptions

Bit	Field	Type	Reset	Description
31-0	EQ	R	0h	32-bit signed value indicating estimated Back EMF along the Q-Axis (Eq). Negative value represented in two's complement. Eq (in Volts) = (EQ / 2 ²⁷) * 60 / sqrt(3)

9.5.37 SPEED_FDBK Register (Offset = 784h) [Reset = 0000000h]

SPEED_FDBK is shown in [Figure 9-50](#) and described in [Table 9-60](#).

Return to the [Summary Table](#).

Speed Feedback Register

Figure 9-50. SPEED_FDBK Register

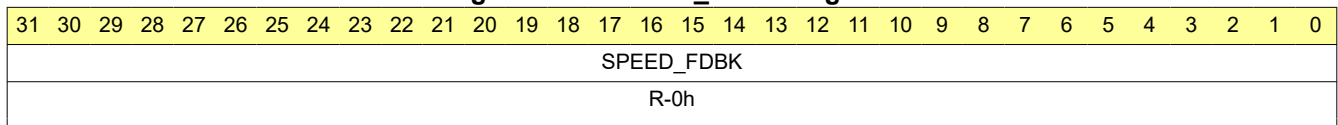

Table 9-60. SPEED_FDBK Register Field Descriptions

Bit	Field	Type	Reset	Description
31-0	SPEED_FDBK	R	0h	32-bit signed value indicating estimated motor speed. Negative value represented in two's complement Estimated motor speed (in Hz) = (SPEED_FDBK / 2 ²⁷) * MAX_SPEED (in Hz)

9.5.38 THETA_EST Register (Offset = 788h) [Reset = 0000000h]

THETA_EST is shown in [Figure 9-51](#) and described in [Table 9-61](#).

Return to the [Summary Table](#).

Estimated rotor Position Register

Figure 9-51. THETA_EST Register

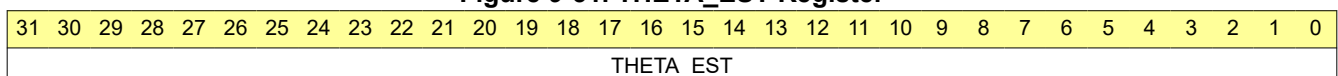

Figure 9-51. THETA_EST Register (continued)

R-0h

Table 9-61. THETA_EST Register Field Descriptions

Bit	Field	Type	Reset	Description
31-0	THETA_EST	R	0h	32-bit signed value indicating estimated rotor angle. Angle should be modulo 360 degrees. For example if the estimated Angle value 380 degrees then it means $380\%360 = 20$ degrees Estimated rotor Angle (in degrees) = $(\text{THETA_EST} / 2^{27}) * 360$

10 Application and Implementation

Note

Information in the following applications sections is not part of the TI component specification, and TI does not warrant its accuracy or completeness. TI's customers are responsible for determining suitability of components for their purposes. Customers should validate and test their design implementation to confirm system functionality

10.1 Application Information

The MCF8329HS is used in 3-phase sensorless motor control applications such as cordless vacuum cleaners, HVAC blowers and ventilators, appliance fans, pumps and medical CPAP blowers.

10.2 Typical Applications

[Figure 10-1](#) shows the typical schematic of MCF8329HS. [Table 7-1](#) shows the recommended values of the external components for the driver.

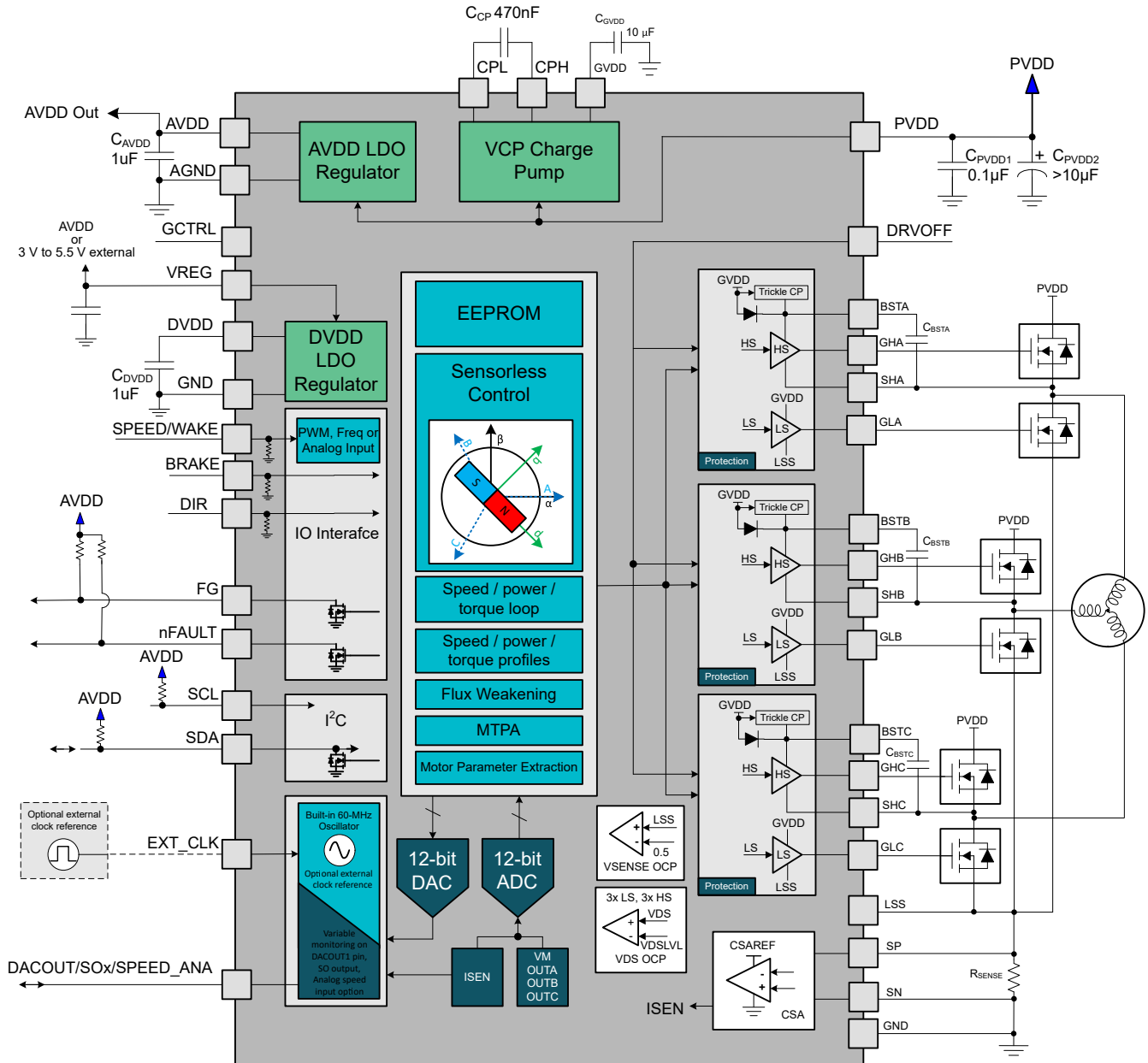

Figure 10-1. Typical schematic of MCF8329HS

Detailed Design Procedure

Table below lists the example input parameters for the system design.

Table 10-1. Design parameters

DESIGN PARAMETERS	REFERENCE	EXAMPLE VALUE
Supply voltage	V_{PVDD}	24V
Motor peak current	I_{PEAK}	20A
PWM Frequency	f_{PWM}	20kHz
MOSFET VDS Slew Rate	SR	120V/us
MOSFET input gate capacitance	Q_G	54 nC
MOSFET input gate capacitance	Q_{GD}	14nC

Table 10-1. Design parameters (continued)

DESIGN PARAMETERS	REFERENCE	EXAMPLE VALUE
Dead time	t_{dead}	200ns
Overcurrent protection	I_{OCP}	30A

Bootstrap Capacitor and GVDD Capacitor Selection

The bootstrap capacitor must be sized to maintain the bootstrap voltage above the undervoltage lockout for normal operation. Equation 14 calculates the maximum allowable voltage drop across the bootstrap capacitor:

$$\Delta V_{BSTX} = V_{GVDD} - V_{BOOTD} - V_{BSTUV} \quad (14)$$

$$\Delta V_{BSTX} = 12V - 0.85V - 4.45V = 6.7V$$

where

- V_{GVDD} is the supply voltage of the gate drive
- V_{BOOTD} is the forward voltage drop of the bootstrap diode
- V_{BSTUV} is the threshold of the bootstrap undervoltage lockout

In the example, allowed voltage drop across bootstrap capacitor is 6.7V. TI generally recommends that ripple voltage on both the bootstrap capacitor and GVDD capacitor are minimized as much as possible. Many of commercial, industrial, and automotive applications use ripple value between 0.5V to 1V.

The total charge needed per switching cycle can be estimated with Equation 15:

$$Q_{TOT} = Q_G + \frac{I_{LBS_TRAN}}{f_{SW}} \quad (15)$$

$$Q_{TOT} = 54nC + 115\mu A / 20kHz = 54nC + 5.8nC = 59.8nC$$

where

- Q_G is the total MOSFET gate charge
- I_{LBS_TRAN} is the bootstrap pin leakage current
- f_{SW} is the PWM frequency

The minimum bootstrap capacitor can then be estimated as below assuming 1V of ΔV_{BSTX} :

$$C_{BST_MIN} = Q_{TOT} / \Delta V_{BSTX} \quad (16)$$

$$C_{BST_MIN} = 59.8nC / 1V = 59.8nF$$

The calculated value of minimum bootstrap capacitor is 59.8nF. Note that, this value of capacitance is needed at full bias voltage. In practice, the value of the bootstrap capacitor must be greater than calculated value to allow for situations where the power stage can skip pulse due to various transient conditions. TI recommends to use a 100nF bootstrap capacitor in this example. TI recommends to include enough margin and place the bootstrap capacitor as close to the BSTx and SHx pins as possible.

$$C_{GVDD} \geq 10 \times C_{BSTX} \quad (17)$$

$$C_{GVDD} = 10 * 100nF = 1\mu F$$

For this example application, choose a 1 μ F C_{GVDD} capacitor. Choose a capacitor with a voltage rating at least twice the maximum voltage that the capacitor is exposed to because most ceramic capacitors lose significant capacitance when biased. This value also improves the long-term reliability of the system.

Note

For higher power system requiring 100% duty cycle support for longer duration TI recommends to use C_{BSTx} of $\geq 1\mu F$ and C_{GVDD} of $\geq 10\mu F$.

10.2.1 Selection of External MOSFET for VREG Power Supply

The MCF8329HS device provides option to drive external MOSFET (using GCTRL pin) which can act as regulator to power internal digital circuitry through VREG pin, as explained in [Section 7.3.4.3](#). Select the external MOSFET to make sure that the VREG pin voltage is between 2.2V to 5.5V across operating conditions. As an example calculation, use [Equation 18](#) for the MOSFET selection to get a minimum VREG pin voltage of 2.4V at a minimum GCTRL pin voltage of 4.9V ($V_{GCTRL(min)} - V_{VREG(min)} = 2.5V$). Use [Equation 19](#) to ensure that the maximum voltage at VREG pin is less than 5.5V at maximum GCTRL pin voltage.

$$V_{GS(th)_{max}} + V_{PVDD} \left(\frac{C_{GD}}{C_{GD} + C_{GCTRL}} \right) + (1.3 \times I_{GATE_LEAK} \times 10^6) < 2.5 V \tag{18}$$

$$V_{GCTRL(max)} - V_{GS(th)_{min}} < 5.5 V \tag{19}$$

where,

$V_{GS(th)_{max}}$ is the maximum gate to source threshold voltage of the external MOSFET across operating condition

$V_{GS(th)_{min}}$ is the minimum gate to source threshold voltage of the external MOSFET across operating condition

V_{PVDD} is the voltage at the drain of the external MOSFET

C_{GD} is the gate to drain capacitance of the external MOSFET

C_{GCTRL} is the capacitance connected between GCTRL pin and GND

I_{GATE_LEAK} is the maximum gate leakage of the external MOSFET

$V_{GCTRL(max)}$ is the maximum voltage at GCTRL pin

The external MOSFET has to be selected so that the GCTRL pin voltage does not peak more than 0.5V from operating maximum value of GCTRL pin voltage and use [Equation 20](#) for the MOSFET selection.

$$V_{PVDD} \left(\frac{C_{GD}}{C_{GD} + C_{GCTRL}} \right) + (1.3 \times I_{GATE_LEAK} \times 10^6) < 0.5 V \tag{20}$$

Table 10-2. Example External MOSFET

Part Number	V _{DS} (V)	Max V _{GS(TH)} (V)	C _{ISS} (pF)	GCTRL-GND Cap (nF)	GCTRL Start up time (ms)
CSD18534Q5A	60	2.3	1770	2	20

Gate Drive Current

Selecting an appropriate gate drive current is essential when turning on or off power MOSFETs gates to switch motor current. The amount of gate drive current and input capacitance of the MOSFETs determines the drain-to-source voltage slew rate (V_{DS}). Gate drive current can be sourced from GVDD into the MOSFET gate (I_{SOURCE}) or sunk from the MOSFET gate into SHx or LSS (I_{SINK}).

Using too high of a gate drive current can turn on MOSFETs too quickly which can cause excessive ringing, dV/dt coupling, or cross-conduction from switching large amounts of current. If parasitic inductances and capacitances exist in the system, voltage spiking or ringing can occur which can damage the MOSFETs or the MCF8329HS device.

Conversely, using too low of a gate drive current causes long V_{DS} slew rates. Turning on the MOSFETs too slowly can heat up the MOSFETs due to $R_{DS,on}$ switching losses.

The relationship between gate drive current I_{GATE} , MOSFET gate-to-drain charge Q_{GD} , and V_{DS} slew rate switching time $t_{rise,fall}$ are described by the following equations:

$$SR_{DS} = \frac{V_{DS}}{t_{rise,fall}} \quad (21)$$

$$I_{GATE} = \frac{Q_{gd}}{t_{rise,fall}} \quad (22)$$

Ti recommends to evaluate at lower gate drive currents and increase gate drive current settings to avoid damage from unintended operation during initial evaluation.

Gate Resistor Selection

The slew rate of the SHx connection will be dependent on the rate at which the gate of the external MOSFETs is controlled. The pull-up/pull-down strength of MCF8329HS is fixed internally, hence the slew rate of gate voltage can be controlled with an external series gate resistor. In some applications, the gate charge of the MOSFET, which is the load on gate driver device, is significantly larger than the gate driver peak output current capability. In such applications, external gate resistors can limit the peak output current of the gate driver. External gate resistors are also used to dampen ringing and noise.

The specific parameters of the MOSFET, system voltage, and board parasitics will all affect the final SHx slew rate, so generally selecting an optimal value or configuration of external gate resistor is an iterative process.

To lower the gate drive current, a series resistor R_{GATE} can be placed on the gate drive outputs to control the current for the source and sink current paths. A single gate resistor will have the same gate path for source and sink gate current, so larger R_{GATE} values will yield similar SHx slew rates. Note that gate drive current varies by PVDD voltage, junction temperature, and process variation of the device.

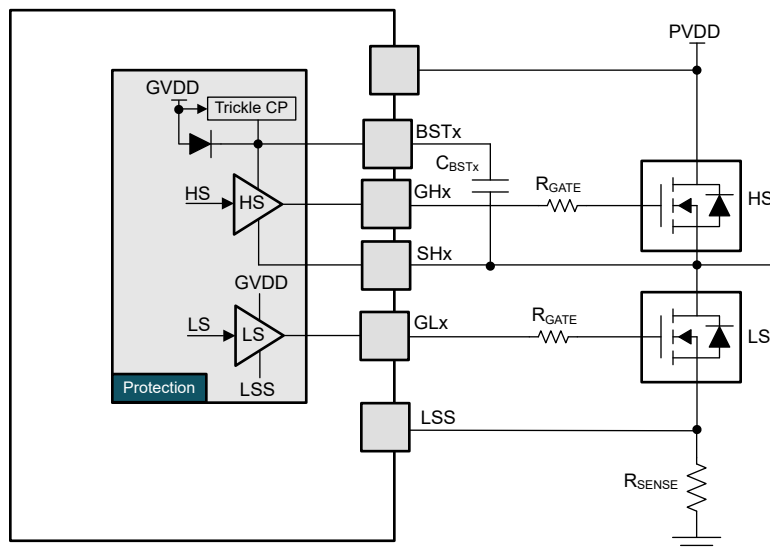

Figure 10-2. Gate driver outputs with series resistors

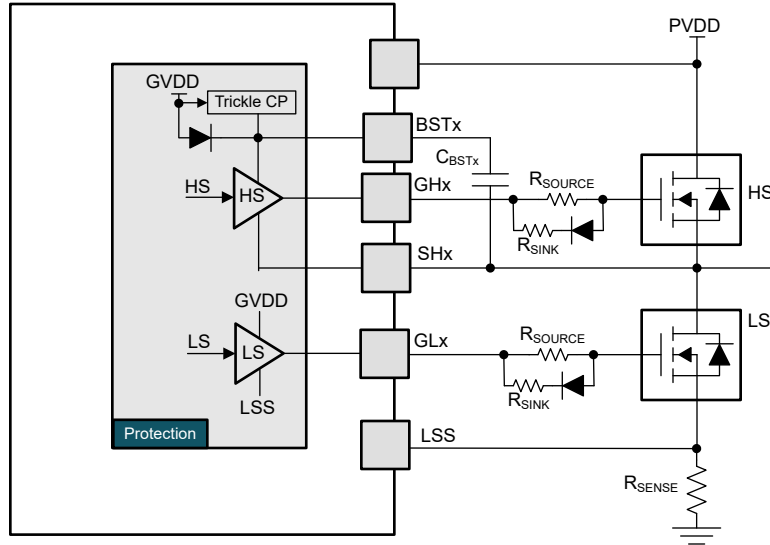

Figure 10-3. Gate driver outputs with separate source and sink current paths

Typically, it is recommended to have the sink current be twice the source current to implement a strong pull-down from gate to the source to ensure the MOSFET stays off while the opposite FET is switching. This can be implemented discretely by providing a separate path through a resistor for the source and sink currents by placing a diode and sink resistor (R_{SINK}) in parallel to the source resistor (R_{SOURCE}). Using the same value of source and sink resistors results in half the equivalent resistance for the sink path. This yields twice the gate drive sink current compared to the source current, and SHx will slew twice as fast when turning off the MOSFET.

System Considerations in High Power Designs

Higher power system designs can require design and application considerations that are not regarded in lower power system designs. It is important to combat the volatile nature of higher power systems by implementing troubleshooting guidelines, external components and circuits, driver product features, or layout techniques. For more information, please visit the [System Design Considerations for High-Power Motor Driver Applications](#) application note.

Capacitor Voltage Ratings

Use capacitors with voltage ratings that are 2x the supply voltage (PVDD, GVDD, AVDD, etc). Capacitors can experience up to half the rated capacitance due to poor DC voltage rating performance.

For example, since the bootstrap voltage is around 12 to 13V with respect to SHx (BSTx-SHx) then the BSTx-SHx capacitor must be rated for 25V or greater.

External Power Stage Components

External components in the power stage are not required by design but are helpful in suppressing transients, managing inductor coil energy, mitigating supply pumping, dampening phase ringing, or providing strong gate-to-source pulldown paths. These components are used for system tuning and debuggability so the BLDC motor system is robust while avoiding damage to the MCF8329HS device or external MOSFETs.

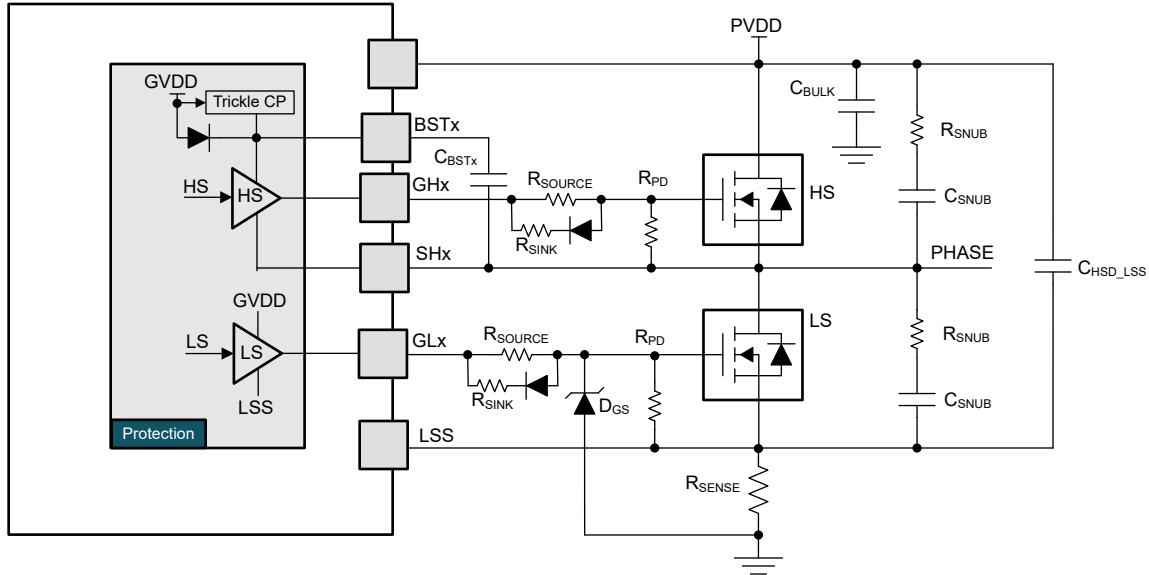

Figure 10-4. Optional external power stage components

Some examples of issues and external components that can resolve those issues are found in table below.

Table 10-3. Common issues and resolutions for power stage debugging

Issue	Resolution	Components
Gate drive current required is too large, resulting in very fast MOSFET V_{DS} slew rate	Series resistors required for gate drive current adjustability	0-100 Ω series resistors (R_{GATE}/R_{SOURCE}) at gate driver outputs (GHx/GLx), optional sink resistor (R_{SINK}) and diode in parallel with gate resistor for adjustable sink current
Ringing at phase's switch node (SHx) resulting in high EMI emissions	RC snubbers placed in parallel to each HS/LS MOSFET to dampen oscillations	Resistor (R_{SNUB}) and Capacitor (C_{SNUB}) placed parallel to the MOSFET, calculate RC values based on ringing frequency using Proper RC Snubber Design for Motor Drivers
Negative transients at low-side source (LSS) below minimum specification	HS drain to LS source capacitor to suppress negative bouncing	0.01 μ F-1 μ F, PVDD-rated capacitor from PVDD-LSS (C_{HSD_LSS}) placed near LS MOSFET's source
Negative transient at low-side gate (GLx) below minimum specification	Gate-to-ground Zener diode to clamp negative voltage	GVDD voltage rated Zener diode (D_{GS}) with anode connected to GND and cathode connected to GLx
Extra protection required to maintain MOSFET is turned off if gate drive signals are Hi-Z	External gate-to-source pulldown resistors (after series gate resistors)	10k Ω to 100k Ω resistor (R_{PD}) connected from gate to source for each MOSFET

10.3 UL Recognized Component: MCF8329HSULIREER

10.3.1 IEC 60730 Functional Safety System (applicable for MCF8329HSULIREER only)

Figure 10-5 shows the block diagram of a IEC 60730 functional safety system with MCF8329HSULIREER.

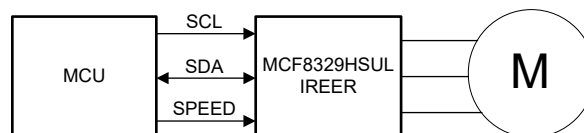

Figure 10-5. IEC 60730 Functional Safety System with MCF8329HSULIREER

An external MCU is needed to communicate with MCF8329HSULIREER over I²C interface to initiate self test sequence, read fault status, report faults to main system controller etc., The reference input command (like speed reference) can be either set using SPEED pin or I²C interface depending on end use requirement. The following points should be considered by end user while designing IEC 60730 functional safety system with MCF8329HSULIREER,

- Suitability of the protective and Class B functions shall be determined in the end use application.
- Built in Self Test (BIST) is the responsibility of the end use application. End use application should initiate BIST sequence over I²C communication with MCF8329HSULIREER; suitability shall be determined in the end use. Refer to [Section 10.3.2](#) for BIST (also known as Self Test Library, STL) initiation procedure.
- Pin level faults were assessed as part of UL recognition. Suitability of the reaction of these faults in the end use application shall be repeated by end user.
- End of manufacturing line routine tests for the protective/Class B function shall be implemented at the end application location.

10.3.2 IEC 60730 Self Test Library (available only in MCF8329HSULIREER)

MCF8329HSULIREER has an integrated Self Test Library (STL) to check the health of critical peripherals used in current and voltage sensing, digital logic and memory during power-up as well as motor operation - an unintended condition/operation detected during these self-tests result in a latched fault with specific fault information provided in CONTROLLER_FAULT_STATUS register.

The self tests performed during power-up can also be initiated by the user. The procedure to initiate self test is as follows,

1. Self test should be initiated only when the device is in idle mode (motor is not driven by the device); hence, stop the motor by issuing a zero reference command. Read ALGORITHM_STATE (from 0x18E) variable to ensure the device is in idle state (read back value should be 0x0) or in fault state (read back value should be 0xE).
2. Write 0x0000037C to ALGO_CTRL1 (at 0xEA) register to initiate self test sequence; initiation of self test sequence results in device reset.
3. Wait for 500ms for the self test sequence to be completed.
4. Read the CONTROLLER_FAULT_STATUS (at 0xE2) register to ensure there was no fault during self test sequence.
5. In case of fault during self test sequence, issue another self test command to check if device recovers. In case of persistent faults, perform a power recycle to check if device recovers; if fault persists or device is unresponsive, the device (critical peripherals, digital logic or memory) may not work as expected.

10.4 Power Supply Recommendations

The MCF8329HS is designed to operate from an input voltage supply (PVDD) range from 4.5V to 60V. A 10µF and 0.1µF ceramic capacitor rated for PVDD must be placed as close to the device as possible. In addition, a bulk capacitor must be included on the PVDD pin but can be shared with the bulk bypass capacitance for the external power MOSFETs. Additional bulk capacitance is required to bypass the external half-bridge MOSFETs and should be sized according to the application requirements.

10.4.1 Bulk Capacitance

Having an appropriate local bulk capacitance is an important factor in motor drive system design. Designs generally benefit in having more bulk capacitance, while the disadvantages are increased cost and physical size.

The amount of local capacitance needed depends on a variety of factors, including:

- The highest current required by the motor system
- The capacitance and current capability of the power supply
- The amount of parasitic inductance between the power supply and motor system
- The acceptable voltage ripple
- The type of motor used (brushed DC, brushless DC, stepper)
- The motor braking method

The inductance between the power supply and the motor drive system limits the rate at which current can change from the power supply. If the local bulk capacitance is too small, the system responds to excessive current demands or dumps from the motor with a change in PVDD voltage. When adequate bulk capacitance is used, the PVDD voltage remains stable and high current can be quickly supplied.

The data sheet generally provides a recommended value, but system-level testing is required to determine the appropriate bulk capacitor. The voltage rating for bulk capacitors needs to be higher than the operating voltage, to provide margin for cases when the motor transfers energy to the supply.

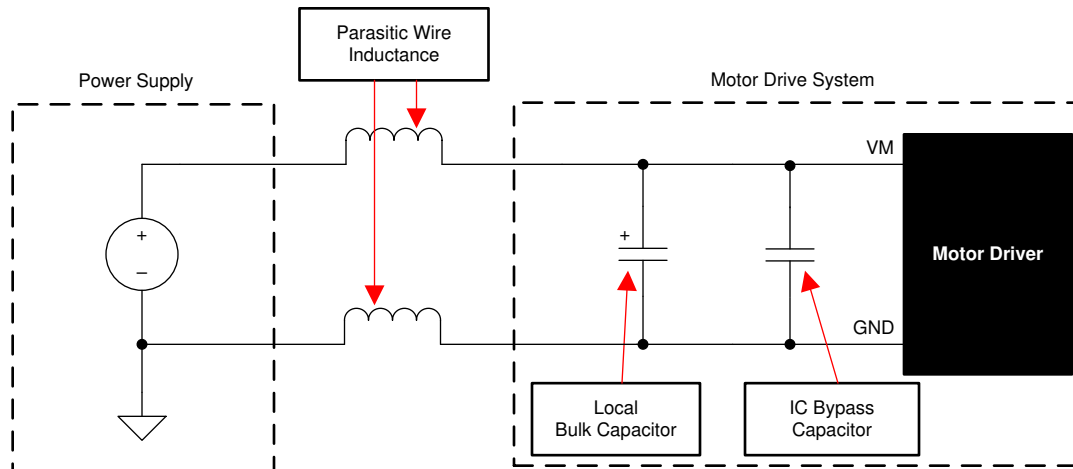

Figure 10-6. Example Setup of Motor Drive System With External Power Supply

10.5 Layout

10.5.1 Layout Guidelines

Bypass the PVDD pin to the GND pin using a low-ESR ceramic bypass capacitor with a recommended value of 0.1 μ F. Place this capacitor as close to the PVDD pin as possible with a thick trace or ground plane connected to the GND pin. Additionally, bypass the PVDD pin using a bulk capacitor rated for PVDD. This component can be electrolytic. This capacitance must be at least 10 μ F.

Additional bulk capacitance is required to bypass the high current path on the external MOSFETs. This bulk capacitance should be placed such that it minimizes the length of any high current paths through the external MOSFETs. The connecting metal traces should be as wide as possible, with numerous vias connecting PCB layers. These practices minimize inductance and let the bulk capacitor deliver high current.

Place a low-ESR ceramic capacitor between the CPL and CPH pins. This capacitor should be 470nF, rated for PVDD, and be of type X7R.

The bootstrap capacitors (BSTx-SHx) should be placed closely to device pins to minimize loop inductance for the gate drive paths.

Bypass the AVDD pin to the AGND pin with a 1 μ F or 2.2 μ F low-ESR ceramic capacitor rated for 10V and of type X7R. Place this capacitor as close to the pin as possible and minimize the path from the capacitor to the AGND pin.

Bypass the DVDD pin to the GND pin with a 1 μ F or 2.2 μ F low-ESR ceramic capacitor rated for 10V and of type X7R. Place this capacitor as close to the pin as possible and minimize the path from the capacitor to the DGND pin.

AVDD and DVDD capacitors should have an effective capacitance between 0.5 μ F and 2.8 μ F after operating voltage (AVDD or DVDD) and temperature derating.

Minimize the loop length for the high-side and low-side gate drivers. The high-side loop is from the GHx pin of the device to the high-side power MOSFET gate, then follows the high-side MOSFET source back to the SHx

pin. The low-side loop is from the GLx pin of the device to the low-side power MOSFET gate, then follows the low-side MOSFET source back to the GND pin.

When designing higher power systems, physics in the PCB layout can cause parasitic inductance, capacitance, and impedance that deter the performance of the system. Understanding the parasitic that are present in a higher power motor drive system can help designers mitigate their effects through good PCB layout. For more information, please visit the [System Design Considerations for High-Power Motor Driver Applications](#) and [Best Practices for Board Layout of Motor Drivers](#) application notes.

Gate drive traces (BSTx, GHx, SHx, GLx, LSS) should be at least 15-20mil wide and as short as possible to the MOSFET gates to minimize parasitic inductance and impedance. This helps supply large gate drive currents, turn MOSFETs on efficiently, and improves VGS and VDS monitoring. Ensure that the shunt resistor selected to monitor the low-side current from LSS to GND, is wide to minimize inductance introduced at the low-side source LSS.

Ensure grounds are connected through net-ties or wide resistors to reduce voltage offsets and maintain gate driver performance. The device thermal pad should be soldered to the PCB top-layer ground plane. Multiple vias should be used to connect to a large bottom-layer ground plane. The use of large metal planes and multiple vias helps dissipate the heat that is generated in the device. To improve thermal performance, maximize the ground area that is connected to the thermal pad ground across all possible layers of the PCB. Using thick copper pours can lower the junction-to-air thermal resistance and improve thermal dissipation from the die surface.

10.5.2 Layout Example

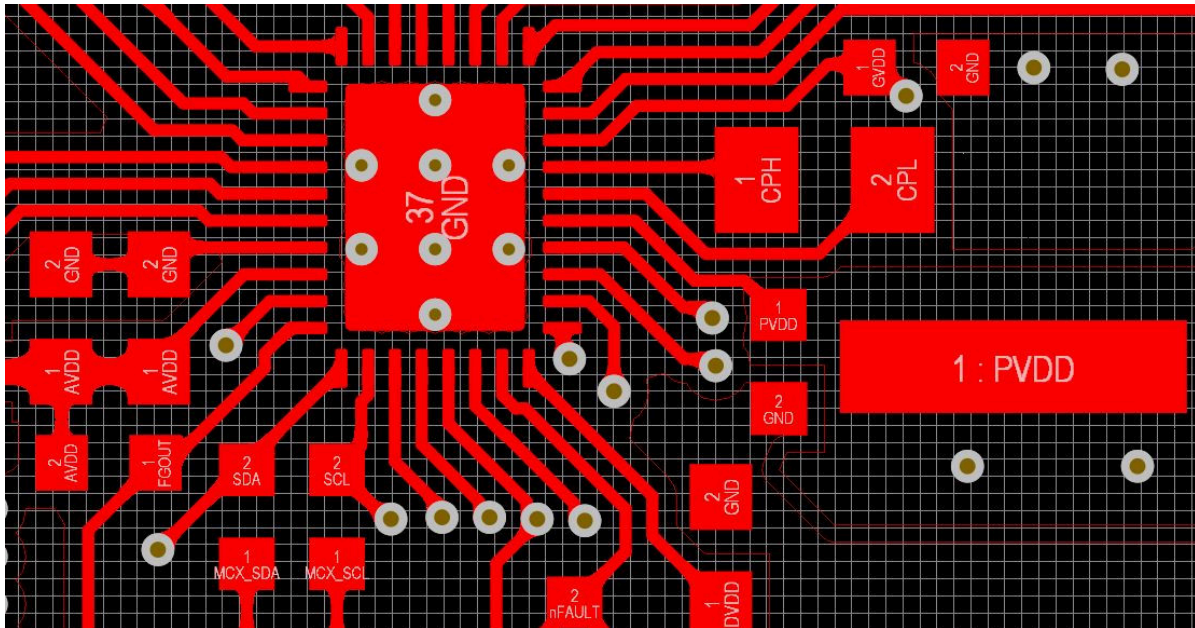

Figure 10-7. Layout example of MCF8329HS device

10.5.3 Thermal Considerations

The MCF8329HS has thermal shutdown (TSD) as previously described. A die temperature in excess of 150°C (minimally) disables the device until the temperature drops to a safe level.

Any tendency of the device to enter thermal shutdown is an indication of excessive power dissipation, insufficient heat-sinking, or too high an ambient temperature.

10.5.3.1 Power Dissipation

The MCF8329HS integrates a variety of circuits that contribute to total power losses. These power losses include standby power losses, GVDD power losses, AVDD power losses, DVDD power losses. At start-up and fault conditions, this current is much higher than normal running current; remember to take these peak currents and their duration into consideration. The maximum amount of power that the device can dissipate depends on ambient temperature and heat-sinking.

11 Device and Documentation Support

11.1 Documentation Support

11.1.1 Related Documentation

- Refer to the application note [Power Delivery in Cordless Power Tools Using DRV8329](#)
- Refer to the application note [System Design Considerations for High-Power Motor Driver Applications](#)
- Refer to the E2E FAQ [How to Conduct a BLDC Schematic Review and Debug](#)
- Refer to the application note [Best Practices for Board Layout of Motor Drivers](#)
- Refer to the application note [QFN and SON PCB Attachment](#)
- Refer to the application note [Cut-Off Switch in High-Current Motor-Drive Applications](#)

11.2 Support Resources

[TI E2E™ support forums](#) are an engineer's go-to source for fast, verified answers and design help — straight from the experts. Search existing answers or ask your own question to get the quick design help you need.

Linked content is provided "AS IS" by the respective contributors. They do not constitute TI specifications and do not necessarily reflect TI's views; see TI's [Terms of Use](#).

11.3 Trademarks

TI E2E™ is a trademark of Texas Instruments.
All trademarks are the property of their respective owners.

11.4 Electrostatic Discharge Caution



This integrated circuit can be damaged by ESD. Texas Instruments recommends that all integrated circuits be handled with appropriate precautions. Failure to observe proper handling and installation procedures can cause damage.

ESD damage can range from subtle performance degradation to complete device failure. Precision integrated circuits may be more susceptible to damage because very small parametric changes could cause the device not to meet its published specifications.

11.5 Glossary

[TI Glossary](#) This glossary lists and explains terms, acronyms, and definitions.

12 Revision History

NOTE: Page numbers for previous revisions may differ from page numbers in the current version.

Changes from Revision * (November 2025) to Revision A (March 2026)	Page
• Removed <i>Recirculation Mode</i> section.....	65
• Removed <i>IPD Faults</i> section.....	79

IMPORTANT NOTICE AND DISCLAIMER

TI PROVIDES TECHNICAL AND RELIABILITY DATA (INCLUDING DATASHEETS), DESIGN RESOURCES (INCLUDING REFERENCE DESIGNS), APPLICATION OR OTHER DESIGN ADVICE, WEB TOOLS, SAFETY INFORMATION, AND OTHER RESOURCES "AS IS" AND WITH ALL FAULTS, AND DISCLAIMS ALL WARRANTIES, EXPRESS AND IMPLIED, INCLUDING WITHOUT LIMITATION ANY IMPLIED WARRANTIES OF MERCHANTABILITY, FITNESS FOR A PARTICULAR PURPOSE OR NON-INFRINGEMENT OF THIRD PARTY INTELLECTUAL PROPERTY RIGHTS.

These resources are intended for skilled developers designing with TI products. You are solely responsible for (1) selecting the appropriate TI products for your application, (2) designing, validating and testing your application, and (3) ensuring your application meets applicable standards, and any other safety, security, regulatory or other requirements.

These resources are subject to change without notice. TI grants you permission to use these resources only for development of an application that uses the TI products described in the resource. Other reproduction and display of these resources is prohibited. No license is granted to any other TI intellectual property right or to any third party intellectual property right. TI disclaims responsibility for, and you fully indemnify TI and its representatives against any claims, damages, costs, losses, and liabilities arising out of your use of these resources.

TI's products are provided subject to [TI's Terms of Sale](#), [TI's General Quality Guidelines](#), or other applicable terms available either on ti.com or provided in conjunction with such TI products. TI's provision of these resources does not expand or otherwise alter TI's applicable warranties or warranty disclaimers for TI products. Unless TI explicitly designates a product as custom or customer-specified, TI products are standard, catalog, general purpose devices.

TI objects to and rejects any additional or different terms you may propose.

Copyright © 2026, Texas Instruments Incorporated

Last updated 10/2025