

SN65HVS885 34-V Digital-Input Serializer for 5-V Systems

1 Features

- Eight Digital Sensor Inputs
 - High Input Voltage up to 34 V
 - Selectable Debounce Filters From 0 ms to 3 ms
 - Flexible Input Current-Limited – 0.2 mA to 5.2 mA
 - Field Inputs Protected to 15-kV ESD
- Single 5-V Supply
- Output Drivers for External Status LEDs
- Cascadable for More Inputs in Multiples of Eight
- SPI-Compatible Interface
- Overtemperature Indicator

2 Applications

- Industrial PCs
- Digital I/O Cards
- High Channel Count Digital Input Modules
- Decentralized I/O Modules

3 Description

The SN65HVS885 is an eight channel, digital-input serializer for high-channel density digital input modules in industrial and building automation. Operating from a 5-V supply the device accepts field input voltages of up to 34 V. In combination with galvanic isolators the device completes the interface between the high voltage signals on the field-side and the low-voltage signals on the controller side. Inputs signals are current limited and then validated by internal debounce filters.

With the addition of few external components, the input switching characteristic can be configured in accordance with IEC61131-2 for Type 1, 2 and 3 sensor switches.

Upon the application of load and clock signals, input data is latched in parallel into the shift register and afterwards clocked out serially.

Cascading of multiple devices is possible by connecting the serial output of the leading device with the serial input of the following device, enabling the design of high-channel count input modules. Multiple devices can be cascaded through a single serial port, reducing both the isolation channels and controller inputs required.

Input status can be visually indicated via constant current LED outputs. The current limit on the inputs is set by a single, external, precision resistor. An on-chip temperature sensor provides diagnostic information for graceful shutdown and system safety.

The SN65HVS885 is available in a 28-pin PWP PowerPAD™ package, allowing for efficient heat dissipation. The device is specified for operation at temperatures from –40°C to 125°C.

Device Information⁽¹⁾

PART NUMBER	PACKAGE	BODY SIZE (NOM)
SN65HVS885	HTSSOP (28)	9.70 mm x 4.40 mm

(1) For all available packages, see the orderable addendum at the end of the datasheet.

Simplified I/O Structure

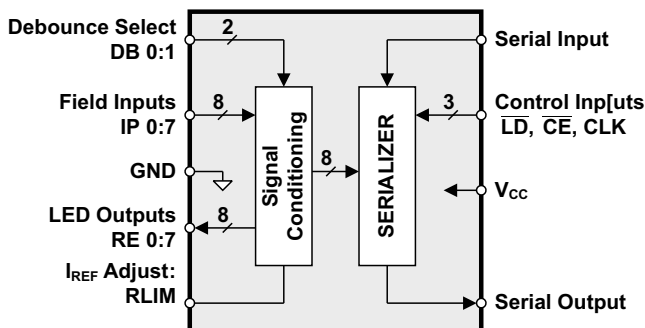

Table of Contents

1 Features	1	8.1 Overview	9
2 Applications	1	8.2 Functional Block Diagram	9
3 Description	1	8.3 Feature Description	10
4 Revision History	2	8.4 Device Functional Modes	12
5 Pin Configuration and Functions	3	9 Application and Implementation	13
6 Specifications	4	9.1 Application Information	13
6.1 Absolute Maximum Ratings	4	9.2 Typical Application	16
6.2 ESD Ratings	4	10 Power Supply Recommendations	19
6.3 Recommended Operating Conditions	4	11 Layout	19
6.4 Thermal Information	4	11.1 Layout Guidelines	19
6.5 Electrical Characteristics	5	11.2 Layout Example	19
6.6 Timing Requirements	5	12 Device and Documentation Support	20
6.7 Switching Characteristics	6	12.1 Community Resources	20
6.8 Typical Characteristics	7	12.2 Trademarks	20
7 Parameter Measurement Information	8	12.3 Electrostatic Discharge Caution	20
7.1 Waveforms	8	12.4 Glossary	20
7.2 Signal Conventions	8	13 Mechanical, Packaging, and Orderable Information	20
8 Detailed Description	9		

4 Revision History

NOTE: Page numbers for previous revisions may differ from page numbers in the current version.

Changes from Original (January 2009) to Revision A

Page

- Added *Pin Configuration and Functions* section, *ESD Ratings* table, *Feature Description* section, *Device Functional Modes*, *Application and Implementation* section, *Power Supply Recommendations* section, *Layout* section, *Device and Documentation Support* section, and *Mechanical, Packaging, and Orderable Information* section **1**

5 Pin Configuration and Functions

PWP Package
28-Pin HTSSOP With Exposed Thermal Pad
Top View

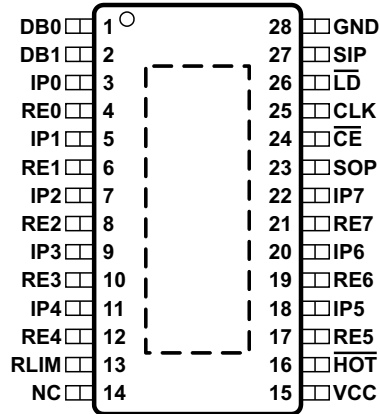

Pin Functions

PIN		DESCRIPTION
NAME	NO.	
CE	24	Clock Enable Input
CLK	25	Serial Clock Input
DB0	1	Debounce select inputs
DB1	2	
GND	28	Device Ground
HOT	16	Over-Temperature Flag
IPx	3, 5, 7, 9, 11, 18, 20, 22	Input Channel x
LD	26	Load Pulse Input
NC	14	Not Connected
REx	4, 6, 8, 10, 12, 17, 19, 21	Return Path x (LED drive)
RLIM	13	Current Limiting Resistor
SIP	27	Serial Data Input
SOP	23	Serial Data Output
VCC	15	5 V Device Supply

6 Specifications

6.1 Absolute Maximum Ratings

 over operating free-air temperature range (unless otherwise noted) ⁽¹⁾

			MIN	MAX	UNIT
V _{CC}	Device power input	V _{CC}	-0.5	6	V
V _{IPx}	Field digital inputs	IPx	-0.3	36	V
V _{ID}	Voltage at any logic input	DB0, DB1, CLK, SIP, \overline{CE} , \overline{LD}	-0.5	6	V
I _O	Output current	\overline{HOT} , SOP	-8	8	mA
P _{TOT}	Continuous total power dissipation		See Thermal Information		
T _J	Junction temperature			170	°C
T _{stg}	Storage temperature			150	°C

- (1) Stresses beyond those listed under "absolute maximum ratings" may cause permanent damage to the device. These are stress ratings only, and functional operation of the device at these or any other conditions beyond those indicated under "recommended operating conditions" is not implied. Exposure to absolute-maximum-rated conditions for extended periods may affect device reliability.

6.2 ESD Ratings

			VALUE	UNIT	
V _(ESD)	Electrostatic discharge	Human body model (HBM), per ANSI/ESDA/JEDEC JS-001 ⁽¹⁾	All pins	±4000	V
			IPx	±15000	
		Charged-device model (CDM), per JEDEC specification JESD22-C101 ⁽²⁾		±1000	
		Machine model (MM) ⁽³⁾		±100	

- (1) JEDEC document JEP155 states that 500-V HBM allows safe manufacturing with a standard ESD control process.
 (2) JEDEC document JEP157 states that 250-V CDM allows safe manufacturing with a standard ESD control process.
 (3) JEDEC Standard 22, Method A115-A

6.3 Recommended Operating Conditions

		MIN	NOM	MAX	UNIT
V _{CC}	Device supply voltage	4.5	5	5.5	V
V _{IPL}	Field input low-state input voltage	0		4	V
V _{IPH}	Field input high-state input voltage	5.5		34	V
V _{IL}	Logic low-state input voltage	0		0.8	V
V _{IH}	Logic high-state input voltage	2.0		5.5	V
R _{LIM}	Current limiter resistor	17	25	500	kΩ
f _{IP} ⁽¹⁾	Input data rate	0		1	Mbps
T _A	Device	-40		125	°C
T _J	Junction Temperature			150	°C

- (1) Maximum data rate corresponds to 0 ms debounce time, (DB0 = open, DB1 = GND), and R_{IN} = 0 Ω

6.4 Thermal Information

THERMAL METRIC ⁽¹⁾			SN65HVS885	UNIT
			5	
			PWP (HTSSOP) 28 PINS	
R _{θJA}	Junction-to-ambient thermal resistance	High-K thermal resistance	35	°C/W
R _{θJC(top)}	Junction-to-case (top) thermal resistance		4.27	°C/W
R _{θJB}	Junction-to-board thermal resistance		15	°C/W
ψ _{JT}	Junction-to-top characterization parameter		0.6	°C/W
ψ _{JB}	Junction-to-board characterization parameter		15.9	°C/W

- (1) For more information about traditional and new thermal metrics, see the *Semiconductor and IC Package Thermal Metrics* application report, [SPRA953](#).

Thermal Information (continued)

THERMAL METRIC ⁽¹⁾	SN65HVS885	UNIT
	5	
	PWP (HTSSOP) 28 PINS	
R _{θJC(bot)} Junction-to-case (bottom) thermal resistance	2.4	°C/W

6.5 Electrical Characteristics

over full-range of recommended operating conditions (unless otherwise noted) all voltages measured against device ground, see [Figure 9](#)

PARAMETER	TERMINAL	TEST CONDITIONS	MIN	TYP	MAX	UNIT
FIELD INPUTS						
V _{TH-(IP)} Low-level device input threshold voltage	IP0–IP7	R _{LIM} = 25 kΩ	4	4.3		V
V _{TH+(IP)} High-level device input threshold voltage			5.2	5.5		V
V _{HYS(IP)} Device input hysteresis			0.9			V
V _{TH-(IN)} Low-level field input threshold voltage	Measured at field side of R _{IN}	4.5 V < V _{CC} < 5.5 V, R _{IN} = 1.2 kΩ ± 5%, R _{LIM} = 25 kΩ, T _A ≤ 125°C	6	8.4		V
V _{TH+(IN)} High-level field input threshold voltage			9.4	10		V
V _{HYS(IN)} Field input hysteresis			1			V
R _{IP} Input resistance	IP0–IP7	3 V < V _{IPx} < 6 V, R _{LIM} = 25 kΩ	0.2	0.63	1.1	kΩ
I _{IP-LIM} Input current limit	IP0–IP7	R _{LIM} = 25 kΩ	3.15	3.6	4	mA
t _{DB} Debounce times of input channels	IP0–IP7	DB0 = open, DB1 = GND		0		ms
		DB0 = GND, DB1 = open		1		
		DB0 = DB1 = open		3		
I _{RE-on} RE on-state current	RE0–RE7	R _{LIM} = 25 kΩ, RE _X = GND	2.8	3.15	3.5	mA
DEVICE SUPPLY						
I _{CC(VCC)} Supply current	V _{CC}	IP0 to IP7 = 24V, RE _X = GND, All logic inputs open		6.5	10	mA
LOGIC INPUTS AND OUTPUTS						
V _{OL} Logic low-level output voltage	SOP, $\overline{\text{HOT}}$	I _{OL} = 20 μA			0.4	V
V _{OH} Logic high-level output voltage		I _{OH} = –20 μA	4			V
I _{IL} Logic input leakage current	DB0, DB1, SIP, $\overline{\text{LD}}$, CE, CLK		–50		50	μA
T _{OVER} Over-temperature indication				150		°C
T _{SHDN} Shutdown temperature				170		°C
POWER DISSIPATION						
P _D Power Dissipation		V _{CC} = 5 V, R _{IN} = 0Ω, R _{LIM} = 25 kΩ, RE0 – RE7 = GND, f _{CLK} = 100 MHz		1100		mW
		IP0-IP7 = 34 V				
		IP0-IP7 = 24 V				
		IP0-IP7 = 20 V				
		IP0-IP7 = 12 V				

6.6 Timing Requirements

over operating free-air temperature range (unless otherwise noted)

			MIN	NOM	MAX	UNIT
t _{W1}	CLK pulse width	See Figure 6	4			ns
t _{W2}	$\overline{\text{LD}}$ pulse width	See Figure 4	6			ns

Timing Requirements (continued)

over operating free-air temperature range (unless otherwise noted)

			MIN	NOM	MAX	UNIT
t_{SU1}	SIP to CLK setup time	See Figure 7	4			ns
t_{H1}	SIP to CLK hold time	See Figure 7	2			ns
t_{SU2}	Falling edge to rising edge (\overline{CE} to CLK) setup time	See Figure 8	4			ns
t_{REC}	\overline{LD} to CLK recovery time	See Figure 5	2			ns
f_{CLK}	Clock pulse frequency	See Figure 6	DC		100	MHz

6.7 Switching Characteristics

over operating free-air temperature range (unless otherwise noted)

PARAMETER		TEST CONDITIONS	MIN	TYP	MAX	UNIT
t_{PLH1}, t_{PHL1}	CLK to SOP	$C_L = 15$ pF, see Figure 6			10	ns
t_{PLH2}, t_{PHL2}	\overline{LD} to SOP	$C_L = 15$ pF, see Figure 4			14	ns
t_r, t_f	Rise and fall times	$C_L = 15$ pF, see Figure 6			6	ns

6.8 Typical Characteristics

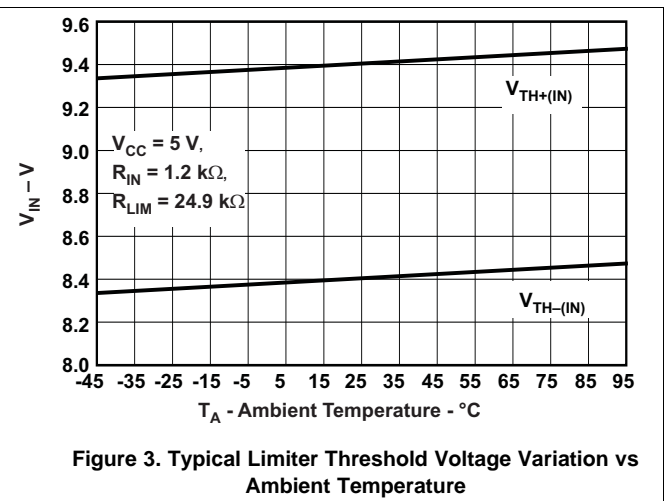
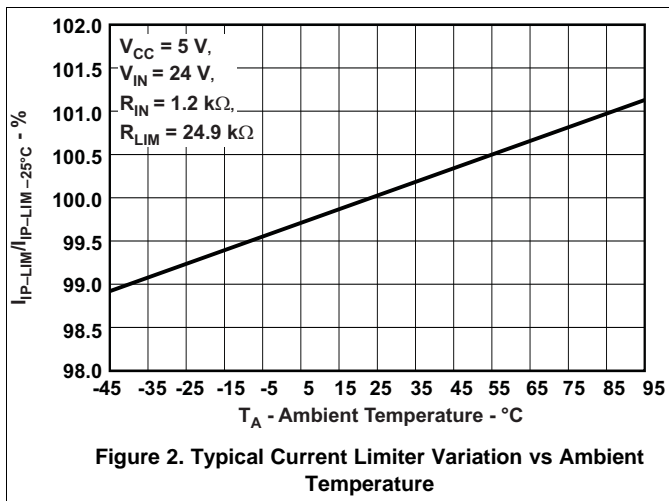
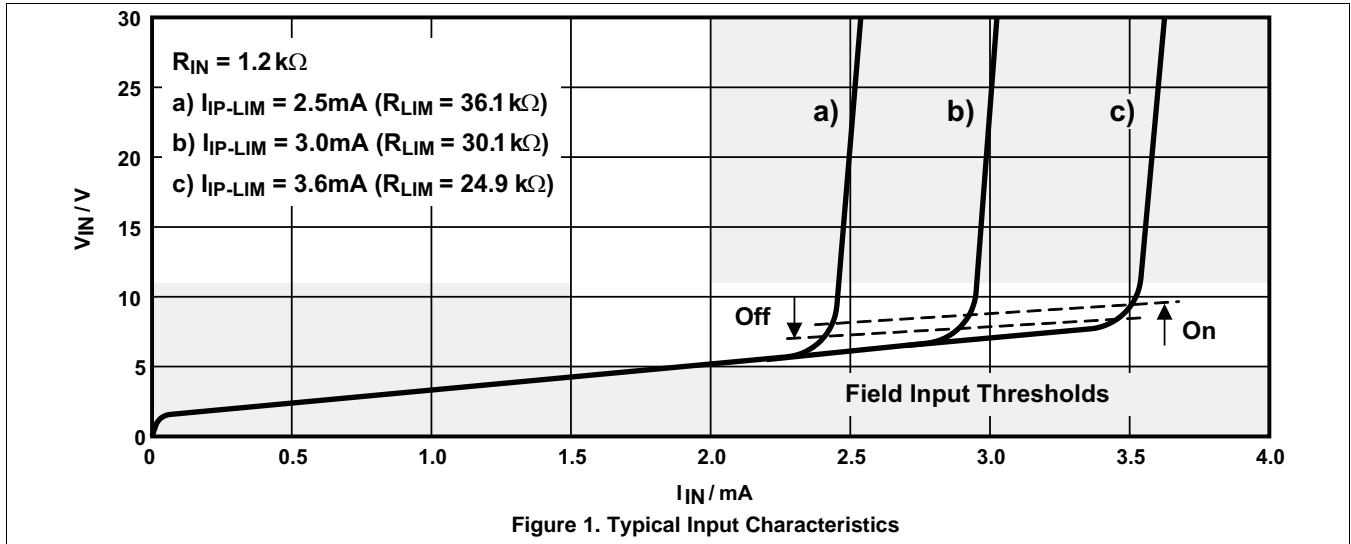

7 Parameter Measurement Information

7.1 Waveforms

For the complete serial interface timing, refer to [Figure 17](#).

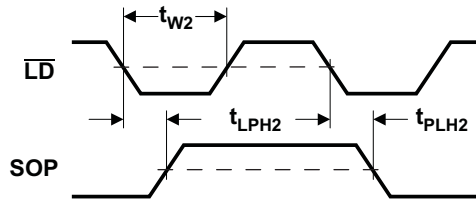

Figure 4. Parallel – Load Mode

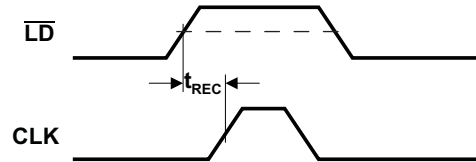

Figure 5. Serial – Shift Mode

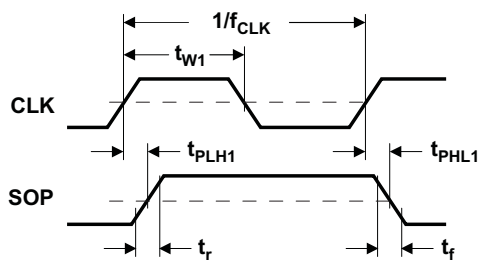

Figure 6. Serial – Shift Mode

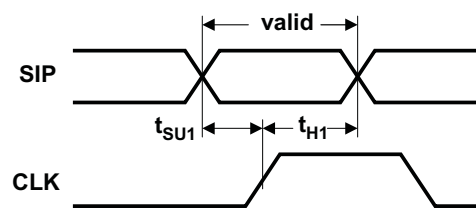

Figure 7. Serial – Shift Mode

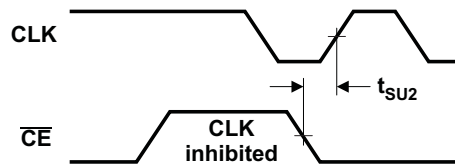

Figure 8. Serial – Shift Mode

7.2 Signal Conventions

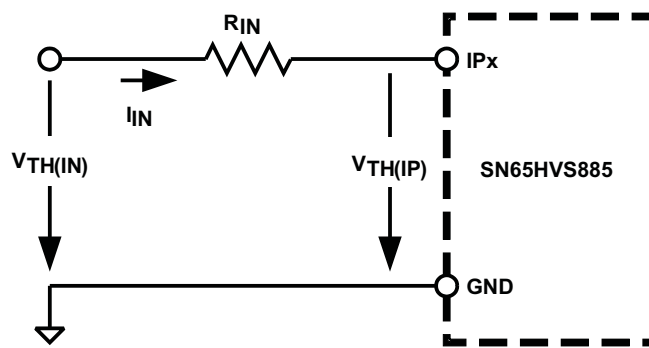

Figure 9. On/Off Threshold Voltage Measurements

8 Detailed Description

8.1 Overview

The SN65HVS885 is an 8 channel, digital input serializer which operates from a 5 V supply and accepts digital inputs of up to 34 V on the 8 channels (IP0-IP7). The device provides a serially shifted digital output with reduced voltage ranges of 0-5 V for applications in industrial and building automation systems. The SN65HVS885 meets JEDEC standards for ESD protection (refer to [ESD Ratings](#)), and is SPI compatible for interfacing with standard microcontrollers. The serializer operates in 2 fundamental modes: Load Mode and Shift mode. In Load mode, information from the field inputs is allowed to latch into the shift register. In Shift mode, the information stored in the parallel shift register can be serially shifted to the serial output (SOP). A detailed description of the functional modes is available in the [Device Functional Modes](#) section.

8.2 Functional Block Diagram

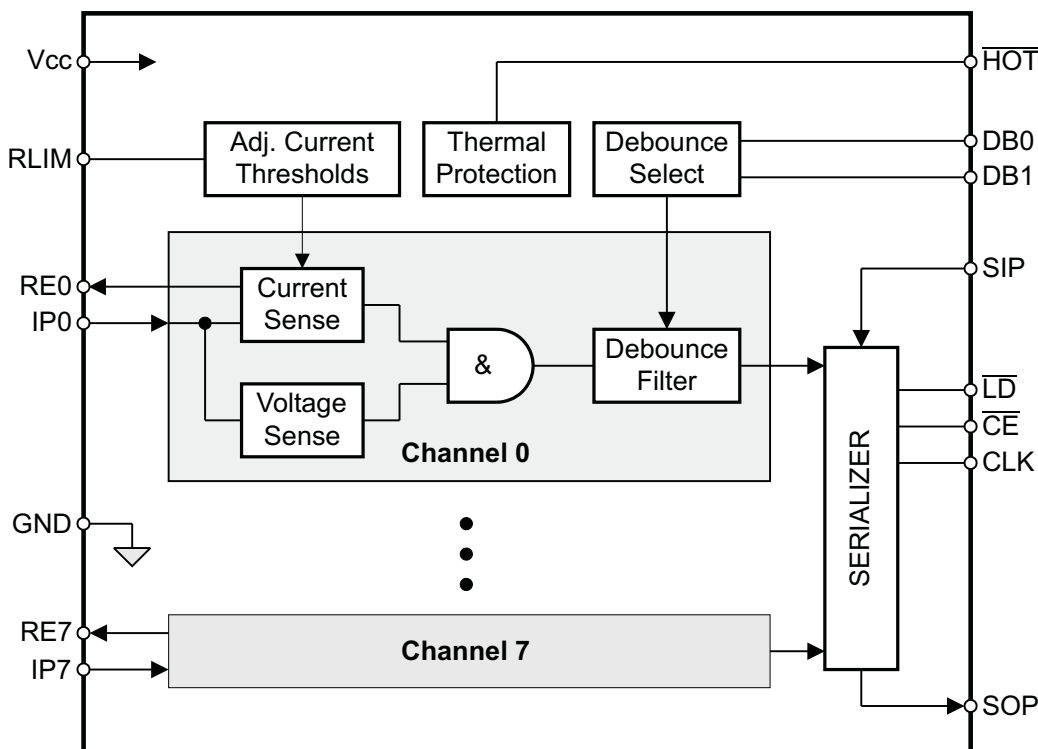

8.3 Feature Description

8.3.1 Digital Inputs

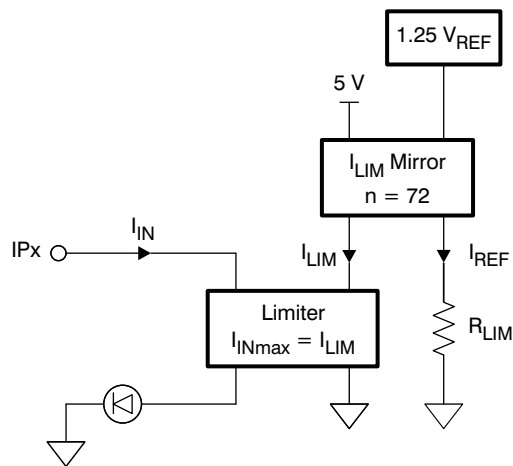

Figure 10. Digital Input Stage

Each digital input operates as a controlled current sink limiting the input current to a maximum value of I_{LIM} . The current limit is derived from the reference current via $I_{LIM} = n \times I_{REF}$, and I_{REF} is determined by $I_{REF} = V_{REF}/R_{LIM}$. Thus, changing the current limit requires the change of R_{LIM} to a different value via: $R_{LIM} = n \times V_{REF}/I_{LIM}$.

Inserting the actual values for n and V_{REF} gives: $R_{LIM} = 90 \text{ V} / I_{LIM}$.

While the device is specified for a current limit of **3.6 mA**, (via $R_{LIM} = 25 \text{ k}\Omega$), it is easy to lower the current limit to further reduce the power consumption. For example, for a current limit of **2.5 mA** simply calculate:

$$R_{LIM} = \frac{90 \text{ V}}{I_{LIM}} = \frac{90 \text{ V}}{2.5 \text{ mA}} = 36 \text{ k}\Omega \quad (1)$$

8.3.2 Debounce Filter

The HVS885 applies a simple analog/digital filtering technique to remove unintended signal transitions due to contact bounce or other mechanical effects. Any new input (either low or high) must be present for the duration of the selected debounce time to be latched into the shift register as a valid state.

The logic signal levels at the control inputs, DB0 and DB1 of the internal Debounce-Select logic determine the different debounce times listed in the following truth table.

Table 1. Debounce Times

DB1	DB0	FUNCTION
Open	Open	3 ms delay
Open	GND	1 ms delay
GND	Open	0 ms delay (Filter bypassed)
GND	GND	Reserved

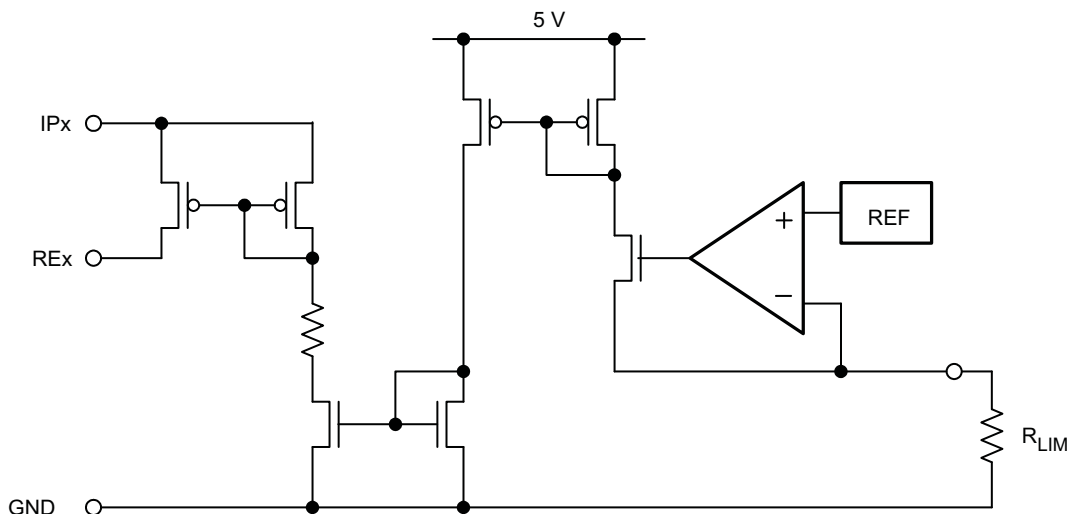

Figure 11. Equivalent Input Diagram

8.3.3 Shift Register

The conversion from parallel input to serial output data is performed by an eight-channel, parallel-in serial-out shift register. Parallel-in access is provided by the internal inputs, PIP0–PIP7, that are enabled by a low level at the load input (\overline{LD}). When clocked, the latched input data shift towards the serial output (SOP). The shift register also provides a clock-enable function.

Clocking is accomplished by a low-to-high transition of the clock (CLK) input while \overline{LD} is held high and the clock enable (CE) input is held low. Parallel loading is inhibited when \overline{LD} is held high. The parallel inputs to the register are enabled while \overline{LD} is low independently of the levels of the CLK, CE, or serial (SIP) inputs.

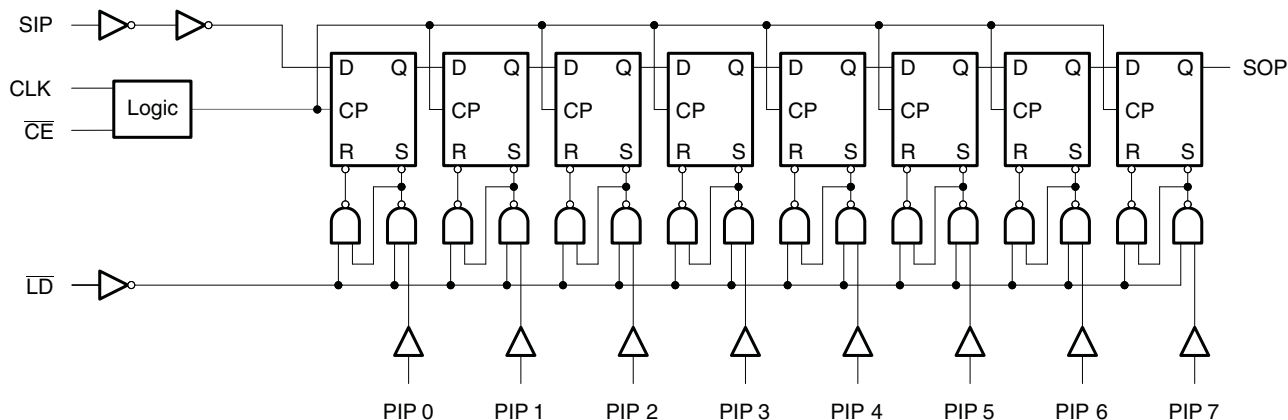

Figure 12. Shift Register Logic Structure

Table 2. Function Table

INPUTS			FUNCTION
\overline{LD}	CLK	\overline{CE}	
L	X	X	Parallel load
H	X	H	No change
H	↑	L	Shift ⁽¹⁾

(1) Shift = content of each internal register shifts towards serial outputs. Data at SIP is shifted into first register.

8.3.4 Temperature Sensor

An on-chip temperature sensor monitors the device temperature and signals a fault condition if the temperature exceeds a first trip point at 150°C by pulling the $\overline{\text{HOT}}$ output low. If the junction temperature continues to rise, passing a second trip point at 170 °C, all device outputs assume high impedance state.

A special condition occurs when the chip temperature exceeds the second temperature trip point due to an output short; the $\overline{\text{HOT}}$ output buffer becomes high impedance, thus separating the buffer from the external circuitry. An internal 100-k Ω pulldown resistor, connecting the $\overline{\text{HOT}}$ -pin to ground, is used as a "cooling down" resistor, which continues to provide a logic low level to the external circuitry.

8.4 Device Functional Modes

The 2 functional modes of operation are Load mode and Shift mode. Load mode enables information from the field inputs to latch into the shift register. To enter load mode, the $\overline{\text{LD}}$ pin must be held low, and the device will remain in load mode regardless of the CLK, $\overline{\text{CE}}$, or serial (SIP) input levels. A high level at the $\overline{\text{LD}}$ pin switches the device into Shift mode. When the device is in Shift mode, a low level at the $\overline{\text{CE}}$ pin will cause the data stored in the parallel shift register to be serially shifted to the serial output (SOP) on the rising edge of CLK. A high level at the $\overline{\text{CE}}$ pin inhibits the serial shifting, which is demonstrated in [Figure 17](#). After 8 consecutive CLK pulses, the serial output (SOP) will remain at the level of the serial input (SIP) which is internally pulled to logic high. A logic high at the $\overline{\text{CE}}$ pin is required to signify the end of the serial data output. In the case of a daisy chained configuration, the serial output (SOP) of the SN65HVS885 can be connected to the serial input (SIP) of a following device, and additional clock pulses are required to shift the additional data out of the chain. The number of consecutive clock pulses will equal 8 times the number of devices in the chain. See [Figure 18](#) for an example of a cascaded chain of 4x SN65HVS885.

9 Application and Implementation

NOTE

Information in the following applications sections is not part of the TI component specification, and TI does not warrant its accuracy or completeness. TI's customers are responsible for determining suitability of components for their purposes. Customers should validate and test their design implementation to confirm system functionality.

9.1 Application Information

9.1.1 System-Level EMC

The SN65HVS885 is designed to operate reliably in harsh industrial environments. At a system level, the device is tested according to several international electromagnetic compatibility (EMC) standards.

In addition to the device internal ESD structures, external protection circuitry shown in Figure 13, can be used to absorb as much energy from burst- and surge-transients as possible.

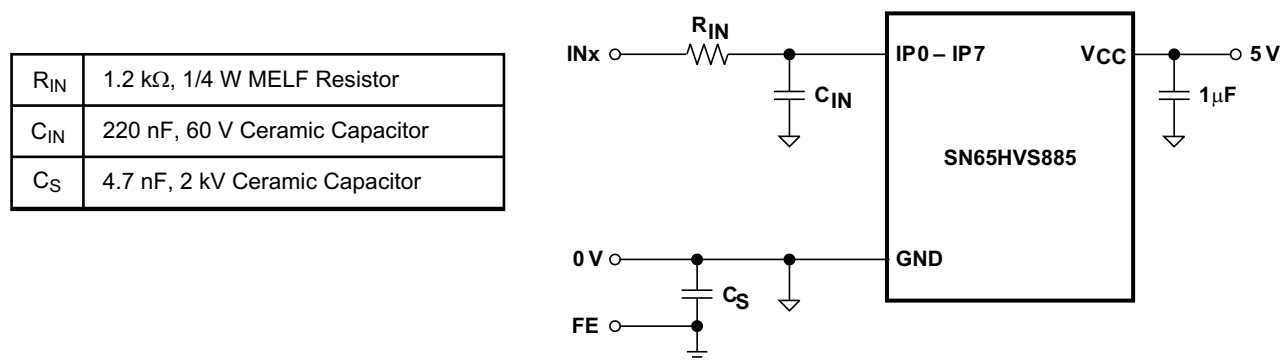

Figure 13. Typical EMC Protection Circuitry for Supply and Signal Inputs

9.1.2 Input Channel Switching Characteristics

The input stage of the HVS885 is so designed, that for an input resistor $R_{IN} = 1.2 \text{ k}\Omega$ the trip point for signaling an ON-condition is at 9.4 V at 3.6 mA. This trip point satisfies the switching requirements of IEC61131-2 Type 1 and Type 3 switches.

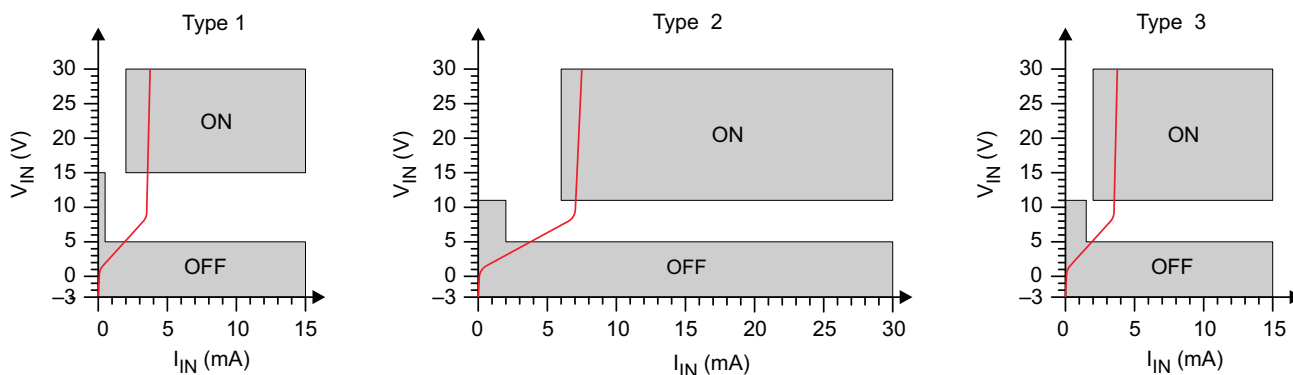

Figure 14. Switching Characteristics for IEC61131-2 Type 1, 2, and 3 Proximity Switches

For a Type 2 switch application, two inputs are connected in parallel. The current limiters then add to a total maximum current of 7.2 mA. While the return-path (RE-pin), of one input might be used to drive an indicator LED, the RE-pin of the other input channel should be connected to ground (GND).

Application Information (continued)

Paralleling input channels reduces the number of available input channels from an octal Type 1 or Type 3 input to a quad Type 2 input device. Note, that in this configuration output data of an input channel is represented by two shift register bits.

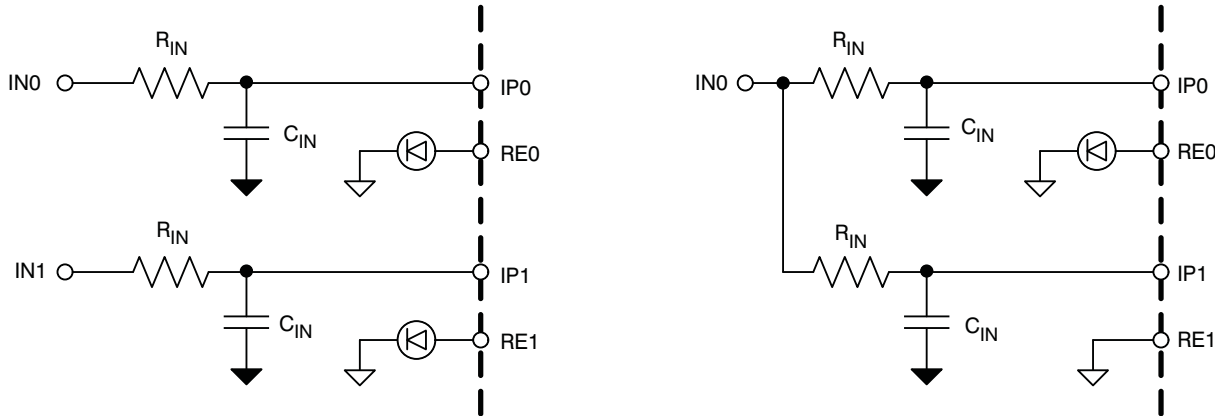

Figure 15. Paralleling Two Type 1 or Type 3 Inputs Into One Type 2 Input

9.1.3 Digital Interface Timing

The digital interface of the SN65HVS885 is SPI compatible and interfaces, isolated or non-isolated, to a wide variety of standard micro controllers.

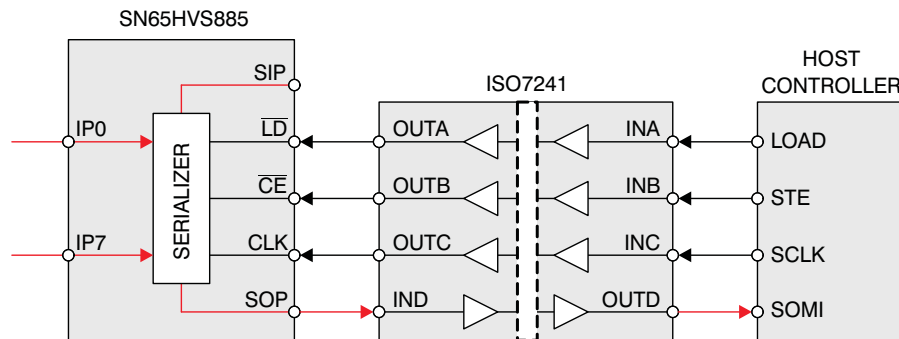

Figure 16. Simple Isolation of the Shift Register Interface

Upon a low-level at the load input, \overline{LD} , the information of the field inputs, IP0 to IP7 is latched into the shift register. Taking \overline{LD} high again blocks the parallel inputs of the shift register from the field inputs. A low-level at the clock-enable input, \overline{CE} , enables the clock signal, CLK, to serially shift the data to the serial output, SOP. Data is clocked at the rising edge of CLK. Thus after eight consecutive clock cycles all field input data have been clocked out of the shift register and the information of the serial input, SIP, appears at the serial output, SOP.

Application Information (continued)

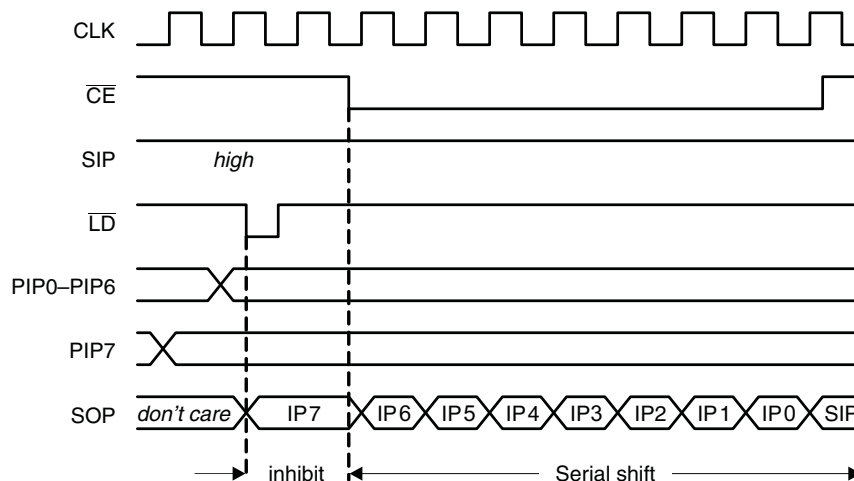

Figure 17. Interface Timing for Parallel-Load and Serial-Shift Operation of the Shift Register

9.1.4 Cascading for High Channel Count Input Modules

Designing high-channel count modules require cascading multiple SN65HVS885 devices. Simply connect the serial output (SOP) of a leading device with the serial input (SIP) of a following device without changing the processor interface.

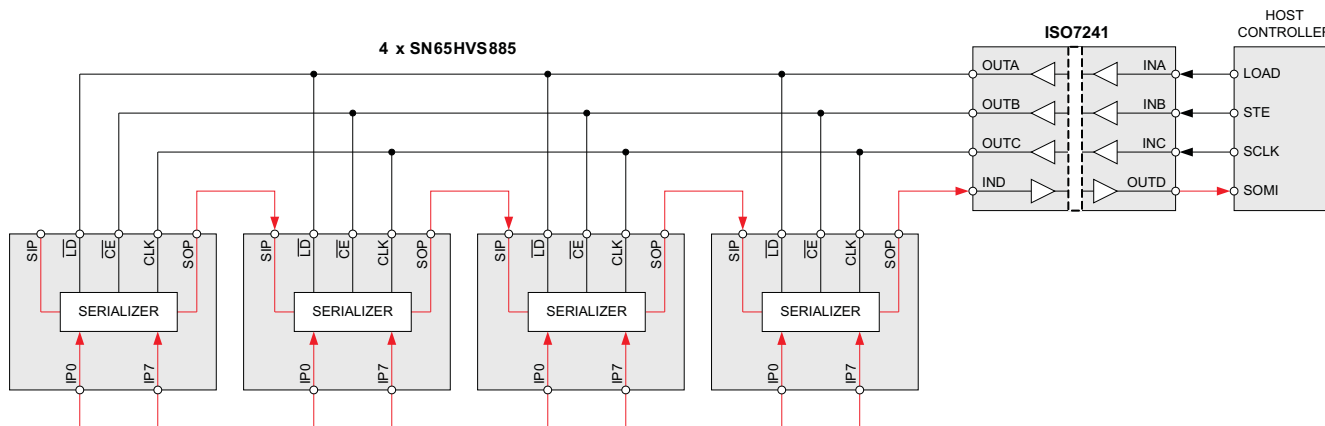

Figure 18. Cascading Four SN65HVS885 for a 32-Channel Input Module

9.2 Typical Application

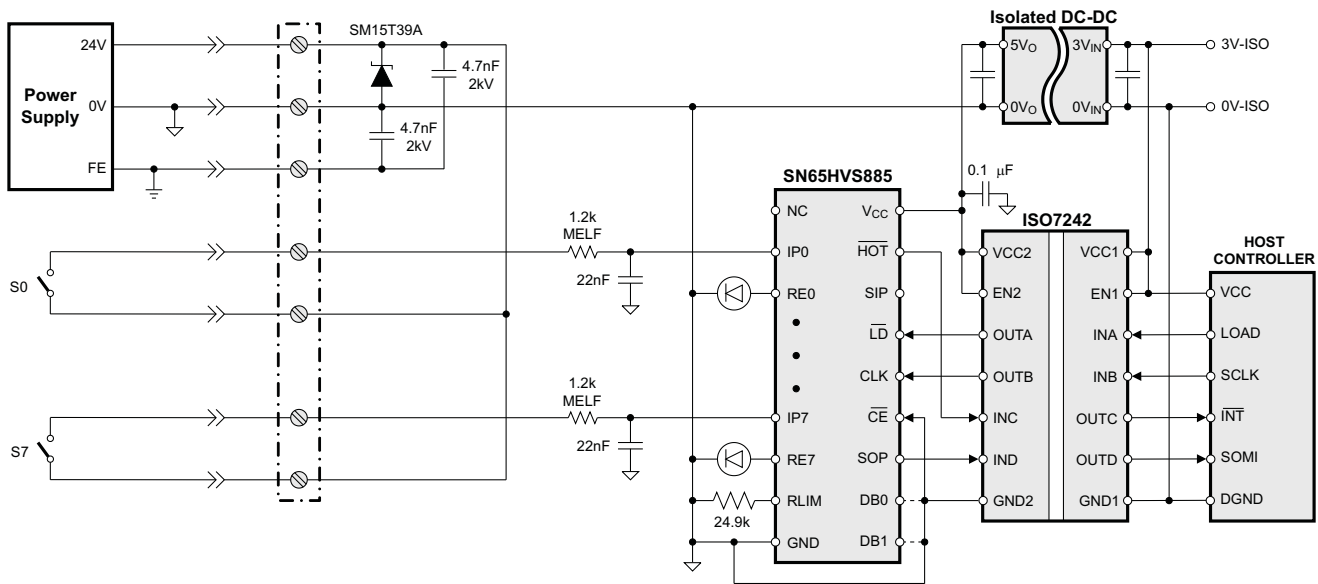

Figure 19. Typical Digital Input Module Application

9.2.1 Design Requirements

The simplified schematic in [Figure 19](#) demonstrates a typical application of the SN65HVS885 for sensing the state of digital switches with 24-V high logic levels. In this application, a 3.3-V host controller must receive the state of 8 switches as a serial input, while remaining isolated from the high voltage power supply.

9.2.2 Detailed Design Procedure

9.2.2.1 Input Stage

Selection of the current limiting resistor R_{LIM} sets the input current limit I_{LIM} for the device. *Digital Inputs* includes necessary equations for choosing the limiting resistor.

The On/Off voltage thresholds at the device pin $V_{TH(IP+)}$ and $V_{TH(IP-)}$ are fixed to 5.2 V and 4.3 V respectively, however the On/Off voltage thresholds of the field input $V_{TH(IN+)}$ and $V_{TH(IN-)}$ are determined by the value of the series resistor R_{IN} placed between the field input and the device. The threshold voltage $V_{TH(IN+)}$ is determined with the following equation:

$$V_{TH(IN+)} = I_{IN} \times R_{IN} + V_{TH(IP+)} \quad (2)$$

Substituting [Equation 1](#) from section 8.3.1, and solving for R_{IN} produces an equation for R_{IN} given a desired on-threshold.

$$R_{IN} = \frac{(V_{TH(IN+)} - 5.2V) \times R_{LIM}}{90V} \quad (3)$$

The following equation can be used to calculate the off-threshold voltage given a value for R_{IN}

$$V_{TH(IN-)} = \frac{90V \times R_{IN}}{R_{LIM}} + V_{TH(IP-)} \quad (4)$$

[Figure 20](#) contains an example input characteristic:

Typical Application (continued)

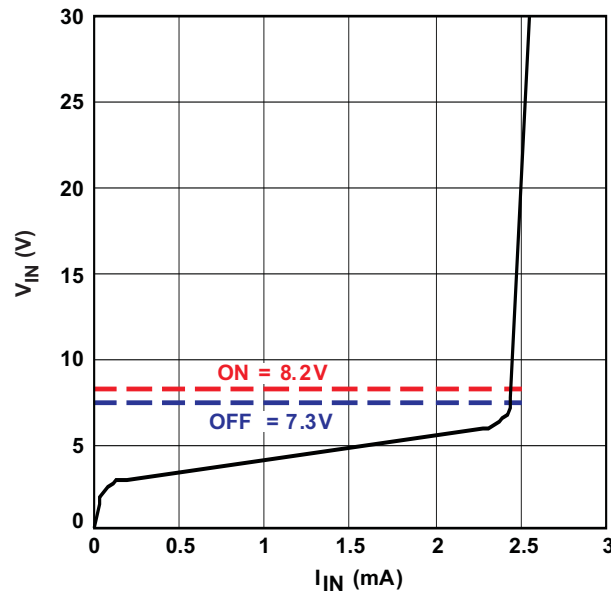

Figure 20. SN65HVS885 Example Input Characteristic

9.2.2.2 Setting Debounce Time

The logic signals at the DB0 and DB1 pins determine the denounce times for the device according to the table in section 6.5. The DB0 and DB1 pins are internally pulled high. Connecting the pins to GND in different configurations allows for selection of 0, 1, or 3ms debounce times. In noisy environments, it is recommended that unused DB pins should be connected externally to a 5 V supply.

9.2.2.3 Using the HOT Indicator

The HOT pin can be used as a visual health indicator for the device. To use the HOT pin as a health indicator, a green LED can be connected (with a series resistor) between the HOT pin and ground. If the device exceeds recommended operating temperature, the LED will turn off. Alternatively, the HOT pin can be connected to the MCU to trigger an interrupt if temperature limits are exceeded.

9.2.2.4 Example: High-Voltage Sensing Application

For the high-voltage sensing application in Figure 19, inputs from each switch (S0-S7) are connected to the 8 parallel inputs (IP0-IP7) of the SN65HVS885 through 1.2kΩ MELF resistors. Small capacitors (22nF) are tied to ground at each input to provide noise protection for the signals. A resistor is added between the R_{LIM} pin and GND to provide a device current limit according to the equation $I_{LIM} = 90 \text{ V} / R_{LIM}$. In this example, with a 24.9kΩ resistor, the current limit for the device is set to 3.6mA. LEDs are placed between pins RE0-RE7 to allow for external status observation of the parallel inputs. Finally the SN65HVS885 is connected through a digital isolation device to the host controller to provide galvanic isolation to the external interfaces and to allow for communication between the 5 V SN65HVS885 logic and the 3.3-V host controller. The host controller manages mode switching and clocking of the SN65HVS885 through the digital isolation device.

Typical Application (continued)

9.2.3 Application Curve

The application traces acquired in [Figure 21](#) demonstrate typical behavior for the SN65HVD885. The trace names in descending order are: Clock Signal (CE), Clock Enable Input (CE), Load Pulse Input (LD), and Serial Data Output (SOP).

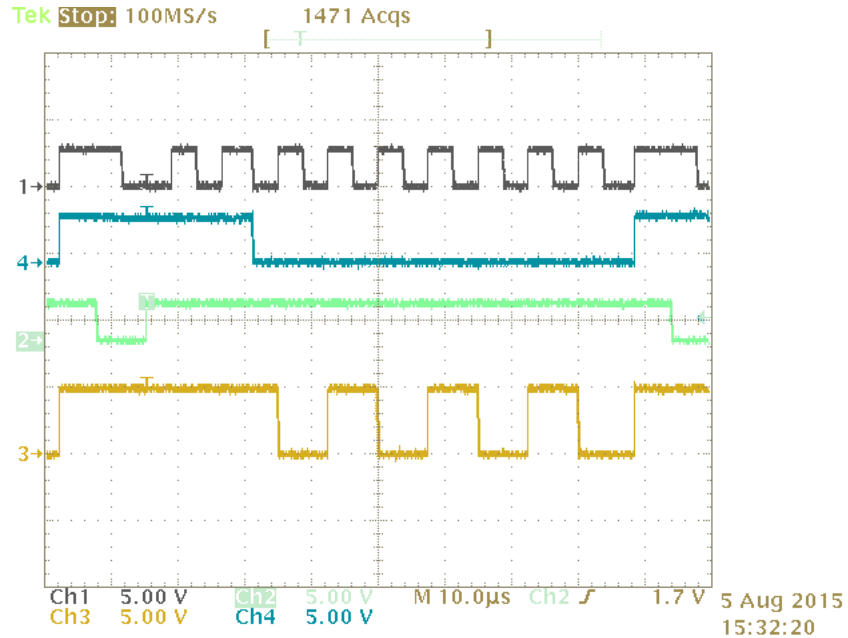

Figure 21. SN65HVD885 Application Measurements

10 Power Supply Recommendations

The SN65HVD885 operates within a recommended supply voltage range from 4.5 V to 5.5 V. A 0.1 μF or larger capacitor should be placed between V_{CC} and ground to improve power supply noise immunity. A current limiting resistor can be used to reduce overall power consumption as described in [Digital Inputs](#). The high voltage parallel field inputs can accept voltages ranging from 0 V to 34 V, however all other inputs must remain between 0 V to 5 V. Refer to the [Recommended Operating Conditions](#) table for more detailed voltage suggestions. High voltage field inputs should be buffered as shown in [Figure 19](#) to improve input noise immunity.

11 Layout

11.1 Layout Guidelines

1. Place series MELF resistors between the field inputs and the device input pins.
2. Place small ~ 22 nF capacitors close to the field input pins to reduce noise.
3. Place a supply buffering 0.1- μF capacitor around as close to the V_{CC} pin as possible.

11.2 Layout Example

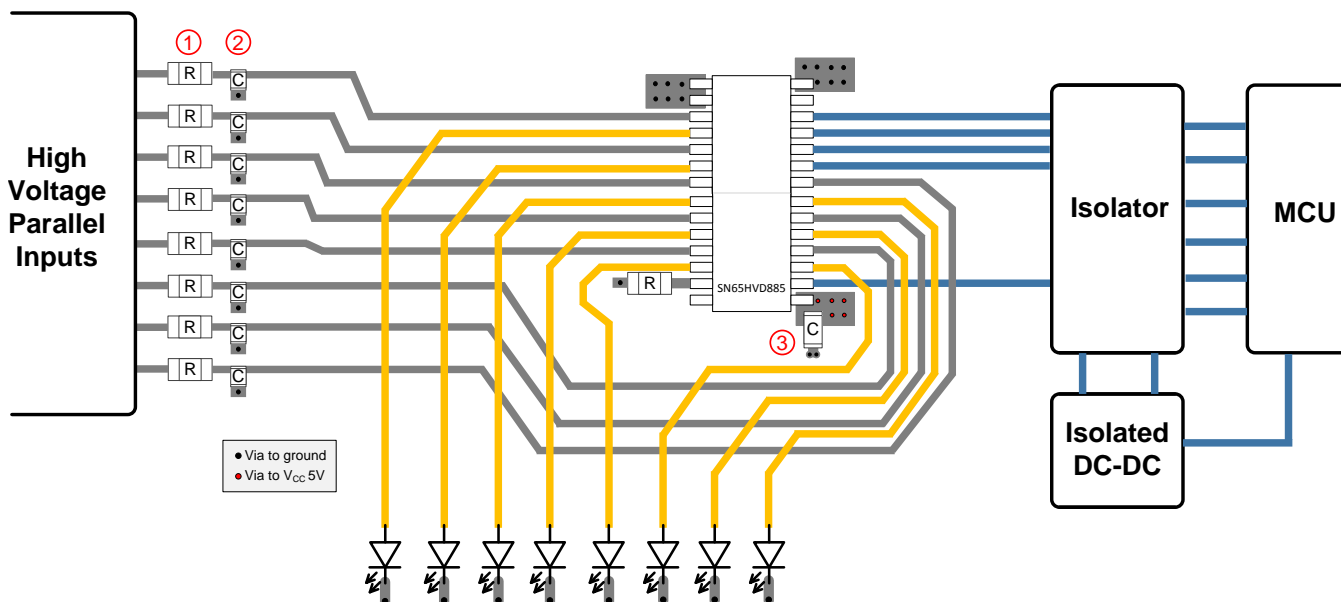

12 Device and Documentation Support

12.1 Community Resources

The following links connect to TI community resources. Linked contents are provided "AS IS" by the respective contributors. They do not constitute TI specifications and do not necessarily reflect TI's views; see TI's [Terms of Use](#).

TI E2E™ Online Community *TI's Engineer-to-Engineer (E2E) Community*. Created to foster collaboration among engineers. At e2e.ti.com, you can ask questions, share knowledge, explore ideas and help solve problems with fellow engineers.

Design Support *TI's Design Support* Quickly find helpful E2E forums along with design support tools and contact information for technical support.

12.2 Trademarks

PowerPAD, E2E are trademarks of Texas Instruments.
All other trademarks are the property of their respective owners.

12.3 Electrostatic Discharge Caution



These devices have limited built-in ESD protection. The leads should be shorted together or the device placed in conductive foam during storage or handling to prevent electrostatic damage to the MOS gates.

12.4 Glossary

[SLYZ022](#) — *TI Glossary*.

This glossary lists and explains terms, acronyms, and definitions.

13 Mechanical, Packaging, and Orderable Information

The following pages include mechanical, packaging, and orderable information. This information is the most current data available for the designated devices. This data is subject to change without notice and revision of this document. For browser-based versions of this data sheet, refer to the left-hand navigation.

PACKAGING INFORMATION

Orderable part number	Status (1)	Material type (2)	Package Pins	Package qty Carrier	RoHS (3)	Lead finish/ Ball material (4)	MSL rating/ Peak reflow (5)	Op temp (°C)	Part marking (6)
SN65HVS885PWPR	Active	Production	HTSSOP (PWP) 28	2000 LARGE T&R	Yes	NIPDAU	Level-2-260C-1 YEAR	-40 to 125	HVS885
SN65HVS885PWPR.A	Active	Production	HTSSOP (PWP) 28	2000 LARGE T&R	Yes	NIPDAU	Level-2-260C-1 YEAR	-40 to 125	HVS885

(1) **Status:** For more details on status, see our [product life cycle](#).

(2) **Material type:** When designated, preproduction parts are prototypes/experimental devices, and are not yet approved or released for full production. Testing and final process, including without limitation quality assurance, reliability performance testing, and/or process qualification, may not yet be complete, and this item is subject to further changes or possible discontinuation. If available for ordering, purchases will be subject to an additional waiver at checkout, and are intended for early internal evaluation purposes only. These items are sold without warranties of any kind.

(3) **RoHS values:** Yes, No, RoHS Exempt. See the [TI RoHS Statement](#) for additional information and value definition.

(4) **Lead finish/Ball material:** Parts may have multiple material finish options. Finish options are separated by a vertical ruled line. Lead finish/Ball material values may wrap to two lines if the finish value exceeds the maximum column width.

(5) **MSL rating/Peak reflow:** The moisture sensitivity level ratings and peak solder (reflow) temperatures. In the event that a part has multiple moisture sensitivity ratings, only the lowest level per JEDEC standards is shown. Refer to the shipping label for the actual reflow temperature that will be used to mount the part to the printed circuit board.

(6) **Part marking:** There may be an additional marking, which relates to the logo, the lot trace code information, or the environmental category of the part.

Multiple part markings will be inside parentheses. Only one part marking contained in parentheses and separated by a "~" will appear on a part. If a line is indented then it is a continuation of the previous line and the two combined represent the entire part marking for that device.

Important Information and Disclaimer:The information provided on this page represents TI's knowledge and belief as of the date that it is provided. TI bases its knowledge and belief on information provided by third parties, and makes no representation or warranty as to the accuracy of such information. Efforts are underway to better integrate information from third parties. TI has taken and continues to take reasonable steps to provide representative and accurate information but may not have conducted destructive testing or chemical analysis on incoming materials and chemicals. TI and TI suppliers consider certain information to be proprietary, and thus CAS numbers and other limited information may not be available for release.

In no event shall TI's liability arising out of such information exceed the total purchase price of the TI part(s) at issue in this document sold by TI to Customer on an annual basis.

TAPE AND REEL INFORMATION

QUADRANT ASSIGNMENTS FOR PIN 1 ORIENTATION IN TAPE

*All dimensions are nominal

Device	Package Type	Package Drawing	Pins	SPQ	Reel Diameter (mm)	Reel Width W1 (mm)	A0 (mm)	B0 (mm)	K0 (mm)	P1 (mm)	W (mm)	Pin1 Quadrant
SN65HVS885PWPR	HTSSOP	PWP	28	2000	330.0	16.4	6.9	10.2	1.8	12.0	16.0	Q1

TAPE AND REEL BOX DIMENSIONS

*All dimensions are nominal

Device	Package Type	Package Drawing	Pins	SPQ	Length (mm)	Width (mm)	Height (mm)
SN65HVS885PWPR	HTSSOP	PWP	28	2000	350.0	350.0	43.0

GENERIC PACKAGE VIEW

PWP 28

PowerPAD™ TSSOP - 1.2 mm max height

4.4 x 9.7, 0.65 mm pitch

SMALL OUTLINE PACKAGE

This image is a representation of the package family, actual package may vary.
Refer to the product data sheet for package details.

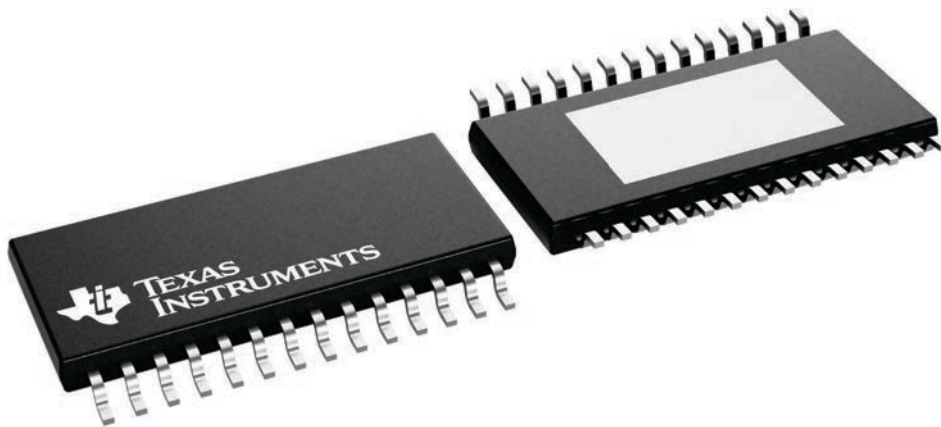

4224765/B

MECHANICAL DATA

PWP (R-PDSO-G28)

PowerPAD™ PLASTIC SMALL OUTLINE



- NOTES:
- All linear dimensions are in millimeters.
 - This drawing is subject to change without notice.
 - Body dimensions do not include mold flash or protrusions. Mold flash and protrusion shall not exceed 0.15 per side.
 - This package is designed to be soldered to a thermal pad on the board. Refer to Technical Brief, PowerPad Thermally Enhanced Package, Texas Instruments Literature No. SLMA002 for information regarding recommended board layout. This document is available at www.ti.com <<http://www.ti.com>>.
 - See the additional figure in the Product Data Sheet for details regarding the exposed thermal pad features and dimensions.
 - Falls within JEDEC MO-153

PowerPAD is a trademark of Texas Instruments.

THERMAL PAD MECHANICAL DATA

PWP (R-PDSO-G28) PowerPAD™ SMALL PLASTIC OUTLINE

THERMAL INFORMATION

This PowerPAD™ package incorporates an exposed thermal pad that is designed to be attached to a printed circuit board (PCB). The thermal pad must be soldered directly to the PCB. After soldering, the PCB can be used as a heatsink. In addition, through the use of thermal vias, the thermal pad can be attached directly to the appropriate copper plane shown in the electrical schematic for the device, or alternatively, can be attached to a special heatsink structure designed into the PCB. This design optimizes the heat transfer from the integrated circuit (IC).

For additional information on the PowerPAD package and how to take advantage of its heat dissipating abilities, refer to Technical Brief, PowerPAD Thermally Enhanced Package, Texas Instruments Literature No. SLMA002 and Application Brief, PowerPAD Made Easy, Texas Instruments Literature No. SLMA004. Both documents are available at www.ti.com.

The exposed thermal pad dimensions for this package are shown in the following illustration.



Top View

Exposed Thermal Pad Dimensions

4206332-33/AO 01/16

NOTE: A. All linear dimensions are in millimeters

B. Exposed tie strap features may not be present.

PowerPAD is a trademark of Texas Instruments

PWP (R-PDSO-G28)

PowerPAD™ PLASTIC SMALL OUTLINE

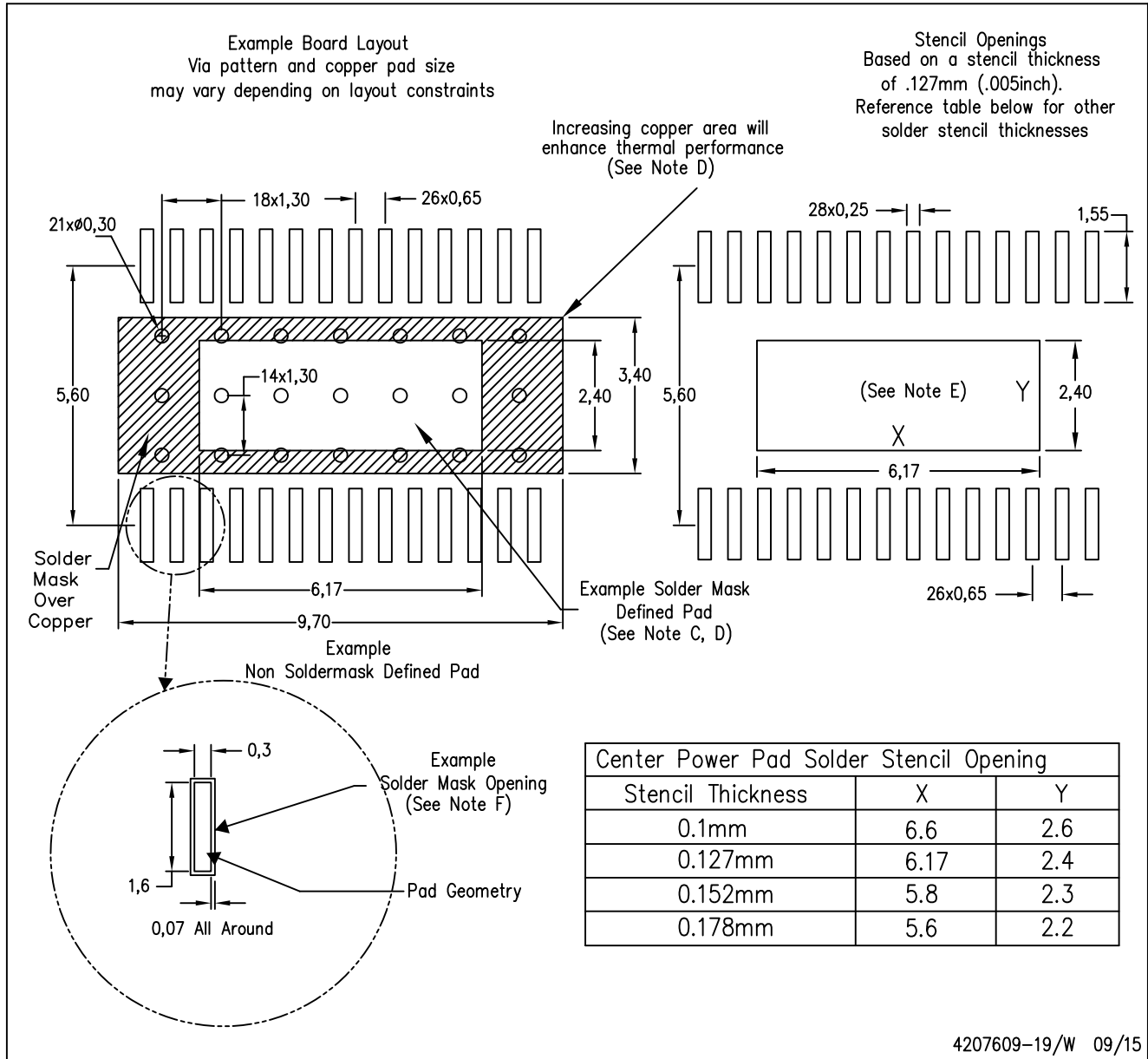

- NOTES:
- All linear dimensions are in millimeters.
 - This drawing is subject to change without notice.
 - Customers should place a note on the circuit board fabrication drawing not to alter the center solder mask defined pad.
 - This package is designed to be soldered to a thermal pad on the board. Refer to Technical Brief, PowerPad Thermally Enhanced Package, Texas Instruments Literature No. SLMA002, SLMA004, and also the Product Data Sheets.
 - For specific thermal information, via requirements, and recommended board layout. These documents are available at www.ti.com <<http://www.ti.com>>. Publication IPC-7351 is recommended for alternate designs. Laser cutting apertures with trapezoidal walls and also rounding corners will offer better paste release. Customers should contact their board assembly site for stencil design recommendations. Example stencil design based on a 50% volumetric metal load solder paste. Refer to IPC-7525 for other stencil
 - Customers should contact their board fabrication site for solder mask tolerances between and around signal pads.

IMPORTANT NOTICE AND DISCLAIMER

TI PROVIDES TECHNICAL AND RELIABILITY DATA (INCLUDING DATASHEETS), DESIGN RESOURCES (INCLUDING REFERENCE DESIGNS), APPLICATION OR OTHER DESIGN ADVICE, WEB TOOLS, SAFETY INFORMATION, AND OTHER RESOURCES "AS IS" AND WITH ALL FAULTS, AND DISCLAIMS ALL WARRANTIES, EXPRESS AND IMPLIED, INCLUDING WITHOUT LIMITATION ANY IMPLIED WARRANTIES OF MERCHANTABILITY, FITNESS FOR A PARTICULAR PURPOSE OR NON-INFRINGEMENT OF THIRD PARTY INTELLECTUAL PROPERTY RIGHTS.

These resources are intended for skilled developers designing with TI products. You are solely responsible for (1) selecting the appropriate TI products for your application, (2) designing, validating and testing your application, and (3) ensuring your application meets applicable standards, and any other safety, security, regulatory or other requirements.

These resources are subject to change without notice. TI grants you permission to use these resources only for development of an application that uses the TI products described in the resource. Other reproduction and display of these resources is prohibited. No license is granted to any other TI intellectual property right or to any third party intellectual property right. TI disclaims responsibility for, and you fully indemnify TI and its representatives against any claims, damages, costs, losses, and liabilities arising out of your use of these resources.

TI's products are provided subject to [TI's Terms of Sale](#), [TI's General Quality Guidelines](#), or other applicable terms available either on ti.com or provided in conjunction with such TI products. TI's provision of these resources does not expand or otherwise alter TI's applicable warranties or warranty disclaimers for TI products. Unless TI explicitly designates a product as custom or customer-specified, TI products are standard, catalog, general purpose devices.

TI objects to and rejects any additional or different terms you may propose.

Copyright © 2025, Texas Instruments Incorporated

Last updated 10/2025