

SN74AVC2T45 2-Bit, Dual Supply, Bus Transceiver with Configurable Level-Shifting and Translation

1 Features

- Available in the Texas Instruments NanoFree™ Package
- V_{CC} Isolation Feature: If Either V_{CC} Input Is at GND, Both Ports Are in the High-Impedance State
- Dual Supply Rail Design
- I/Os Are 4.6V Over Voltage Tolerant
- I_{off} Supports Partial-Power-Down Mode Operation
- Max Data Rates
 - 500Mbps (1.8V to 3.3V)
 - 320Mbps (<1.8V to 3.3V)
 - 320Mbps (Level-Shifting to 2.5V or 1.8V)
 - 280Mbps (Level-Shifting to 1.5V)
 - 240Mbps (Level-Shifting to 1.2V)
- Latch-Up Performance Exceeds 100mA Per JESD 78, Class II
- ESD Protection Exceeds JESD 22

2 Applications

- Smartphones
- Servers
- Desktop PCs and notebooks
- Other portable devices

3 Description

This 2-bit non-inverting bus transceiver uses two separate configurable power-supply rails. The A ports are designed to track V_{CCA} and accepts any supply voltage from 1.2V to 3.6V. The B ports are designed to track V_{CCB} and accepts any supply voltage from 1.2V to 3.6V. This allows for universal low-voltage bidirectional translation and level-shifting between any of the 1.2V, 1.5V, 1.8V, 2.5V, and 3.3V voltage nodes.

The SN74AVC2T45 is designed for asynchronous communication between two data buses. The logic levels of the direction-control (DIR pin) input activate either the B-port outputs or the A-port outputs. The device transmits data from the A bus to the B bus when the B-port outputs are activated and from the B bus to the A bus when the A-port outputs are activated. The input circuitry on both A and B ports always is active and must have a logic HIGH or LOW level applied to prevent excess leakage current on the internal CMOS structure.

Package Information

PART NUMBER	PACKAGE ⁽¹⁾	BODY SIZE (NOM)
SN74AVC2T45DCT	DCT, (SSOP, 8)	2.95mm × 2.80mm
SN74AVC2T45DCU	DCU (VSSOP, 8)	2.30mm × 2.00mm
SN74AVC2T45YZP	YZP (DSBGA, 8)	1.89mm × 0.89mm
SN74AVC2T45DDF	DDF (SOT-23, 8)	2.90mm × 1.60mm

(1) For all available packages, see Section 11.

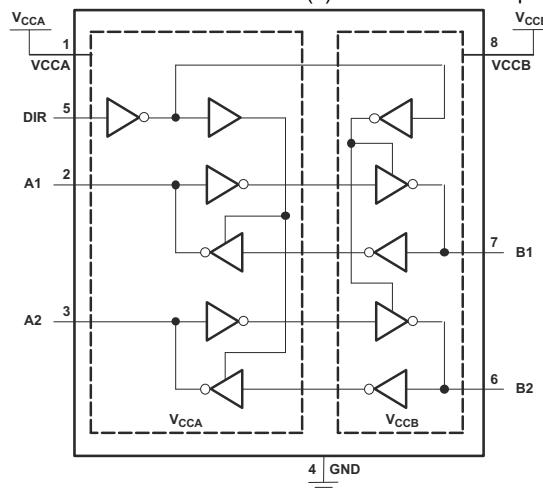

A. Pin numbers are for the DCT and DCU packages only.

Logic Diagram (Positive Logic)



Table of Contents

1 Features	1	7.1 Overview.....	13
2 Applications	1	7.2 Functional Block Diagram.....	13
3 Description	1	7.3 Feature Description.....	14
4 Pin Configuration and Functions	3	7.4 Device Functional Modes.....	14
Pin Functions.....	3	8 Application and Implementation	15
5 Specifications	4	8.1 Application Information.....	15
5.1 Absolute Maximum Ratings.....	4	8.2 Typical Applications.....	15
5.2 ESD Ratings.....	4	8.3 Power Supply Recommendations.....	17
5.3 Recommended Operating Conditions.....	5	8.4 Layout.....	18
5.4 Thermal Information.....	6	9 Device and Documentation Support	19
5.5 Electrical Characteristics.....	6	9.1 Documentation Support.....	19
5.6 Switching Characteristics: $V_{CCA} = 1.2V$	7	9.2 Receiving Notification of Documentation Updates....	19
5.7 Switching Characteristics: $V_{CCA} = 1.5V \pm 0.1V$	7	9.3 Support Resources.....	19
5.8 Switching Characteristics: $V_{CCA} = 1.8V \pm 0.15V$	8	9.4 Trademarks.....	19
5.9 Switching Characteristics: $V_{CCA} = 2.5V \pm 0.2V$	8	9.5 Electrostatic Discharge Caution.....	19
5.10 Switching Characteristics: $V_{CCA} = 3.3V \pm 0.3V$	9	9.6 Glossary.....	19
5.11 Operating Characteristics.....	9	10 Revision History	19
5.12 Typical Characteristics.....	10	11 Mechanical, Packaging, and Orderable Information	20
6 Parameter Measurement Information	12		
7 Detailed Description	13		

4 Pin Configuration and Functions

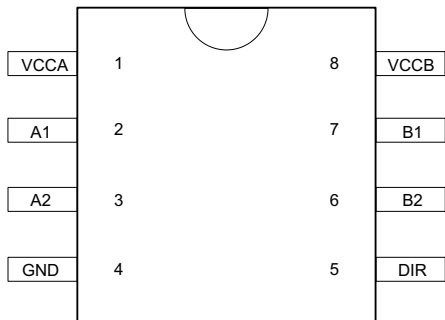

Figure 4-1. DCT or DCU Package 8-Pin SM8 or VSSOP Top View

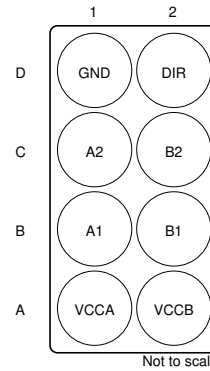

Figure 4-2. YZP Package 8-Pin DSBGA Bottom View

Pin Functions

NAME	PIN		TYPE ⁽¹⁾	DESCRIPTION
	NO. (SM8, VSSOP)	NO. (DSBGA)		
VCCA	1	A1	—	Supply Voltage A
VCCB	8	A2	—	Supply Voltage B
GND	4	D1	—	Ground
A1	2	B1	I/O	Output or input depending on state of DIR. Output level depends on V_{CCA} .
A2	3	C1	I/O	Output or input depending on state of DIR. Output level depends on V_{CCA} .
B1	7	B2	I/O	Output or input depending on state of DIR. Output level depends on V_{CCB} .
B2	6	C2	I/O	Output or input depending on state of DIR. Output level depends on V_{CCB} .
DIR	5	D2	I	Direction Pin, Connect to GND or to VCCA

(1) I = Input; O = Output; I/O = Input or Output

5 Specifications

5.1 Absolute Maximum Ratings

over operating free-air temperature range (unless otherwise noted)⁽¹⁾

		MIN	MAX	UNIT	
V_{CCA} V_{CCB}	Supply voltage	-0.5	4.6	V	
V_I	Input voltage ⁽²⁾	IO ports (A port)	-0.5	4.6	V
		IO ports (B port)	-0.5	4.6	
		Control inputs	-0.5	4.6	
V_O	Voltage applied to any output in the high-impedance or power-off state ⁽²⁾	A port	-0.5	4.6	V
		B port	-0.5	4.6	
V_O	Voltage applied to any output in the high or low state ^{(2) (3)}	A port	-0.5	$V_{CCA} + 0.5$	V
		B port	-0.5	$V_{CCB} + 0.5$	
I_{IK}	Input clamp current	$V_I < 0$	-50	mA	
I_{OK}	Output clamp current	$V_O < 0$	-50	mA	
I_O	Continuous output current		±50	mA	
	Continuous current through V_{CCA} , V_{CCB} , or GND		±100	mA	
T_J	Junction temperature		150	°C	
T_{stg}	Storage temperature	-65	150	°C	

(1) Operation outside the *Absolute Maximum Ratings* may cause permanent device damage. *Absolute Maximum Ratings* do not imply functional operation of the device at these or any other conditions beyond those listed under *Recommended Operating Conditions*.

If used outside the *Recommended Operating Conditions* but within the *Absolute Maximum Ratings*, the device may not be fully functional, and this may affect device reliability, functionality, performance, and shorten the device lifetime.

(2) The input negative-voltage and output voltage ratings can be exceeded if the input and output current ratings are observed.

(3) The output positive-voltage rating can be exceeded up to 4.6 V maximum if the output current ratings are observed.

5.2 ESD Ratings

		VALUE	UNIT
$V_{(ESD)}$	Electrostatic discharge	Human body model (HBM), per ANSI/ESDA/JEDEC JS-001 ⁽¹⁾	±8000
		Charged-device model (CDM), per JEDEC specification JESD22-C101 ⁽²⁾	±1000
		Machine Model (MM), Per JEDEC specification JESD22-A115-A	±200

(1) JEDEC document JEP155 states that 500V HBM allows safe manufacturing with a standard ESD control process.

(2) JEDEC document JEP157 states that 250V CDM allows safe manufacturing with a standard ESD control process.

5.3 Recommended Operating Conditions

 See ⁽³⁾ ⁽⁴⁾ ⁽⁵⁾

		$V_{CCI}^{(1)}$	$V_{CCO}^{(2)}$	MIN	MAX	UNIT
V_{CCA}	Supply voltage			1.2	3.6	V
V_{CCB}	Supply voltage			1.2	3.6	V
V_{IH}	High-level input voltage	Data inputs ⁽⁴⁾	1.2V to 1.95V	$V_{CCI}^{(1)} \times 0.65$		V
			1.95V to 2.7V	1.6		
			2.7V to 3.6V	2		
V_{IL}	Low-level input voltage	Data inputs ⁽⁴⁾	1.2V to 1.95V	$V_{CCI}^{(1)} \times 0.35$		V
			1.95V to 2.7V	0.7		
			2.7V to 3.6V	0.8		
V_{IH}	High-level input voltage	DIR (referenced to V_{CCA}) ⁽⁵⁾	1.2V to 1.95V	$V_{CCA} \times 0.65$		V
			1.95V to 2.7V	1.6		
			2.7V to 3.6V	2		
V_{IL}	Low-level input voltage	DIR (referenced to V_{CCA}) ⁽⁵⁾	1.2V to 1.95V	$V_{CCA} \times 0.35$		V
			1.95V to 2.7V	0.7		
			2.7V to 3.6V	0.8		
V_I	Input voltage			0	3.6	V
V_O	Output voltage	Active state		0	$V_{CCO}^{(2)}$	V
		3-state		0	3.6	
I_{OH}	High-level output current		1.2V	-3		mA
			1.4V to 1.6V	-6		
			1.65V to 1.95V	-8		
			2.3V to 2.7V	-9		
			3V to 3.6V	-12		
I_{OL}	Low-level output current		1.2V	3		mA
			1.4V to 1.6V	6		
			1.65V to 1.95V	8		
			2.3V to 2.7V	9		
			3V to 3.6V	12		
$\Delta t/\Delta v$	Input transition rise or fall rate				5	ns/V
T_A	Operating free-air temperature			-40	85	°C

(1) V_{CCI} is the voltage associated with the input port supply V_{CCA} or V_{CCB} .

(2) V_{CCO} is the voltage associated with the output port supply V_{CCA} or V_{CCB} .

(3) All unused data inputs of the device must be held at V_{CCI} or GND to provide proper device operation. See [Implications of Slow or Floating CMOS Inputs](#).

(4) For V_{CCI} values not specified in the data sheet, $V_{IH} \text{ min} = V_{CCI} \times 0.7V$, $V_{IL} \text{ max} = V_{CCI} \times 0.3V$.

(5) For V_{CCI} values not specified in the data sheet, $V_{IH} \text{ min} = V_{CCA} \times 0.7V$, $V_{IL} \text{ max} = V_{CCA} \times 0.3V$.

5.4 Thermal Information

THERMAL METRIC ⁽¹⁾		SN74AVC2T45				UNIT
		DCT (SM8)	DCU (VSSOP)	DDF (SOT-23)	YZP (DSBGA)	
		8 PINS	8 PINS	8 PINS	8 PINS	
R _{θJA}	Junction-to-ambient thermal resistance	183.1	246.9	203.2	105.8	°C/W
R _{θJC(top)}	Junction-to-case (top) thermal resistance	101.5	95.2	121.5	1.6	°C/W
R _{θJB}	Junction-to-board thermal resistance	111.0	158.4	99.8	10.8	°C/W
ψ _{JT}	Junction-to-top characterization parameter	27.6	34.1	21.4	3.1	°C/W
ψ _{JB}	Junction-to-board characterization parameter	109.2	157.5	99.5	10.8	°C/W

(1) For more information about traditional and new thermal metrics, see the [Semiconductor and IC Package Thermal Metrics](#) application note.

5.5 Electrical Characteristics

over recommended operating free-air temperature range (unless otherwise noted)^{(1) (2)}

PARAMETER	TEST CONDITIONS	V _{CCA}	V _{CCB}	T _A = 25°C			-40°C to +85°C		UNIT
				MIN	TYP	MAX	MIN	MAX	
V _{OH} ⁽³⁾	I _{OH} = -100μA	V _I = V _{IH}	1.2V to 3.6V	1.2V to 3.6V			V _{CCO} - 0.2V		V
	I _{OH} = -3mA		1.2V	1.2V	0.95				
	I _{OH} = -6mA		1.4V	1.4V		1.05			
	I _{OH} = -8mA		1.65V	1.65V		1.2			
	I _{OH} = -9mA		2.3V	2.3V		1.75			
	I _{OH} = -12mA		3V	3V		2.3			
V _{OL} ⁽³⁾	I _{OL} = 100μA	V _I = V _{IL}	1.2V to 3.6V	1.2V to 3.6V			0.2		V
	I _{OL} = 3mA		1.2V	1.2V	0.25				
	I _{OL} = 6mA		1.4V	1.4V		0.35			
	I _{OL} = 8mA		1.65V	1.65V		0.45			
	I _{OL} = 9mA		2.3V	2.3V		0.55			
	I _{OL} = 12mA		3V	3V		0.7			
I _I	DIR	V _I = V _{CCA} or GND	1.2V to 3.6V	1.2V to 3.6V	±0.025	±0.25	±1		μA
I _{off}	A port	V _I or V _O = 0 to 3.6V	0V	0 to 3.6V	±0.1	±1	±5		μA
	B port		0 to 3.6V	0V	±0.1	±1	±5		
I _{OZ} ⁽³⁾	B port	V _O = V _{CCO} or GND, V _I = V _{CCI} or GND	0V	3.6V	±0.5	±2.5	±5		μA
	A port		3.6V	0V	±0.5	±2.5	±5		
I _{CCA} ⁽³⁾		V _I = V _{CCI} or GND, I _O = 0	1.2V to 3.6V	1.2V to 3.6V			10		μA
			0V	3.6V			-2		
			3.6V	0V			10		
I _{CCB} ⁽³⁾		V _I = V _{CCI} or GND, I _O = 0	1.2V to 3.6V	1.2V to 3.6V			10		μA
			0V	3.6V			10		
			3.6V	0V			-2		
I _{CCA} + I _{CCB} (see Table 5-1)		V _I = V _{CCI} or GND, I _O = 0	1.2V to 3.6V	1.2V to 3.6V			20		μA
C _I	Control inputs	V _I = 3.3V or GND	3.3V	3.3V	2.5				pF
C _{io}	A or B port	V _O = 3.3V or GND	3.3V	3.3V	6				pF

(1) V_{CCO} is the voltage associated with the output port supply V_{CCA} or V_{CCB}.

(2) V_{CCI} is the voltage associated with the input port supply V_{CCA} or V_{CCB}.

(3) V_{OH}: Output High Voltage; V_{OL}: Output Low Voltage; I_{OZ}: Hi-Z Output Current; I_{CCA}: Supply A Current; I_{CCB}: Supply B Current

5.6 Switching Characteristics: $V_{CCA} = 1.2V$

over recommended operating free-air temperature range, $V_{CCA} = 1.2V$ (see [Figure 6-1](#))

PARAMETER	FROM (INPUT)	TO (OUTPUT)	$V_{CCB} = 1.2V$	$V_{CCB} = 1.5V$	$V_{CCB} = 1.8V$	$V_{CCB} = 2.5V$	$V_{CCB} = 3.3V$	UNIT
			TYP	TYP	TYP	TYP	TYP	
$t_{PLH}^{(2)}$	A	B	3.1	2.6	2.4	2.2	2.2	ns
$t_{PHL}^{(2)}$			3.1	2.6	2.4	2.2	2.2	
$t_{PLH}^{(2)}$	B	A	3.4	3.1	3	2.9	2.9	ns
$t_{PHL}^{(2)}$			3.4	3.1	3	2.9	2.9	
$t_{PHZ}^{(2)}$	DIR	A	5.2	5.2	5.1	5	4.8	ns
$t_{PLZ}^{(2)}$			5.2	5.2	5.1	5	4.8	
$t_{PHZ}^{(2)}$	DIR	B	5	4	3.8	2.8	3.2	ns
$t_{PLZ}^{(2)}$			5	4	3.8	2.8	3.2	
$t_{PZH}^{(2)(1)}$	DIR	A	8.4	7.1	6.8	5.7	6.1	ns
$t_{PZL}^{(2)(1)}$			8.4	7.1	6.8	5.7	6.1	
$t_{PZH}^{(2)(1)}$	DIR	B	8.3	7.8	7.5	7.2	7	ns
$t_{PZL}^{(2)(1)}$			8.3	7.8	7.5	7.2	7	

(1) The enable time is a calculated value, derived using the formula shown in the [Section 8.2.2.1](#) section.

(2) t_{PLH} : Low-to-high Propagation Delay; t_{PHL} : High-to-Low Propagation Delay; t_{PHZ} : High-to-Hi-Z Propagation Delay; t_{PLZ} : Low-to-Hi-Z Propagation Delay; t_{PZH} : Hi-Z-to-High Propagation Delay; t_{PZL} : Hi-Z-to-Low Propagation Delay

5.7 Switching Characteristics: $V_{CCA} = 1.5V \pm 0.1V$

over recommended operating free-air temperature range, $V_{CCA} = 1.5V \pm 0.1V$ (see [Figure 6-1](#))

PARAMETER	FROM (INPUT)	TO (OUTPUT)	$V_{CCB} = 1.2V$	$V_{CCB} = 1.5V \pm 0.1V$		$V_{CCB} = 1.8V \pm 0.15V$		$V_{CCB} = 2.5V \pm 0.2V$		$V_{CCB} = 3.3V \pm 0.3V$		UNIT
			TYP	MIN	MAX	MIN	MAX	MIN	MAX	MIN	MAX	
$t_{PLH}^{(2)}$	A	B	2.8	0.7	5.4	0.5	4.6	0.4	3.7	0.3	3.5	ns
$t_{PHL}^{(2)}$			2.8	0.7	5.4	0.5	4.6	0.4	3.7	0.3	3.5	
$t_{PLH}^{(2)}$	B	A	2.7	0.8	5.4	0.7	5.2	0.6	4.9	0.5	4.7	ns
$t_{PHL}^{(2)}$			2.7	0.8	5.4	0.7	5.2	0.6	4.9	0.5	4.7	
$t_{PHZ}^{(2)}$	DIR	A	3.9	1.3	8.5	1.3	7.8	1.1	7.7	1.4	7.6	ns
$t_{PLZ}^{(2)}$			3.9	1.3	8.5	1.3	7.8	1.1	7.7	1.4	7.6	
$t_{PHZ}^{(2)}$	DIR	B	4.7	1.1	7	1.4	6.9	1.2	6.9	1.7	7.1	ns
$t_{PLZ}^{(2)}$			4.7	1.1	7	1.4	6.9	1.2	6.9	1.7	7.1	
$t_{PZH}^{(2)(1)}$	DIR	A	7.4		12.4		12.1		11.8		11.8	ns
$t_{PZL}^{(2)(1)}$			7.4		12.4		12.1		11.8		11.8	
$t_{PZH}^{(2)(1)}$	DIR	B	6.7		13.9		12.4		11.4		11.1	ns
$t_{PZL}^{(2)(1)}$			6.7		13.9		12.4		11.4		11.1	

(1) The enable time is a calculated value, derived using the formula shown in the [Section 8.2.2.1](#) section.

(2) t_{PLH} : Low-to-high Propagation Delay; t_{PHL} : High-to-Low Propagation Delay; t_{PHZ} : High-to-Hi-Z Propagation Delay; t_{PLZ} : Low-to-Hi-Z Propagation Delay; t_{PZH} : Hi-Z-to-High Propagation Delay; t_{PZL} : Hi-Z-to-Low Propagation Delay

5.8 Switching Characteristics: $V_{CCA} = 1.8V \pm 0.15V$

over recommended operating free-air temperature range, $V_{CCA} = 1.8V \pm 0.15V$ (see [Figure 6-1](#))

PARAMETER	FROM (INPUT)	TO (OUTPUT)	$V_{CCB} = 1.2V$	$V_{CCB} = 1.5V \pm 0.1V$		$V_{CCB} = 1.8V \pm 0.15V$		$V_{CCB} = 2.5V \pm 0.2V$		$V_{CCB} = 3.3V \pm 0.3V$		UNIT
			TYP	MIN	MAX	MIN	MAX	MIN	MAX	MIN	MAX	
$t_{PLH}^{(2)}$	A	B	2.7	0.5	5.2	0.4	4.3	0.2	3.4	0.2	3.1	ns
$t_{PHL}^{(2)}$			2.7	0.5	5.2	0.4	4.3	0.2	3.4	0.2	3.1	
$t_{PLH}^{(2)}$	B	A	2.4	0.7	4.7	0.5	4.4	0.5	4	0.4	3.8	ns
$t_{PHL}^{(2)}$			2.4	0.7	4.7	0.5	4.4	0.5	4	0.4	3.8	
$t_{PHZ}^{(2)}$	DIR	A	3.7	1.3	8.1	0.7	6.9	1.4	5.3	1.1	5.2	ns
$t_{PLZ}^{(2)}$			3.7	1.3	8.1	0.7	6.9	1.4	5.3	1.1	5.2	
$t_{PHZ}^{(2)}$	DIR	B	4.4	1.3	5.8	1.3	5.9	0.8	5.7	1.5	5.9	ns
$t_{PLZ}^{(2)}$			4.4	1.3	5.8	1.3	5.9	0.8	5.7	1.5	5.9	
$t_{PZH}^{(2)(1)}$	DIR	A	6.8		10.5		10.3		9.7		9.7	ns
$t_{PZL}^{(2)(1)}$			6.8		10.5		10.3		9.7		9.7	
$t_{PZH}^{(2)(1)}$	DIR	B	6.4		13.3		11.2		8.7		8.3	ns
$t_{PZL}^{(2)(1)}$			6.4		13.3		11.2		8.7		8.3	

(1) The enable time is a calculated value, derived using the formula shown in the [Section 8.2.2.2.1](#) section.

(2) t_{PLH} : Low-to-high Propagation Delay; t_{PHL} : High-to-Low Propagation Delay; t_{PHZ} : High-to-Hi-Z Propagation Delay; t_{PLZ} : Low-to-Hi-Z Propagation Delay; t_{PZH} : Hi-Z-to-High Propagation Delay; t_{PZL} : Hi-Z-to-Low Propagation Delay

5.9 Switching Characteristics: $V_{CCA} = 2.5V \pm 0.2V$

over recommended operating free-air temperature range, $V_{CCA} = 2.5V \pm 0.2V$ (see [Figure 6-1](#))

PARAMETER	FROM (INPUT)	TO (OUTPUT)	$V_{CCB} = 1.2V$	$V_{CCB} = 1.5V \pm 0.1V$		$V_{CCB} = 1.8V \pm 0.15V$		$V_{CCB} = 2.5V \pm 0.2V$		$V_{CCB} = 3.3V \pm 0.3V$		UNIT
			TYP	MIN	MAX	MIN	MAX	MIN	MAX	MIN	MAX	
$t_{PLH}^{(2)}$	A	B	2.6	0.4	4.9	0.2	4	0.2	3	0.2	2.6	ns
$t_{PHL}^{(2)}$			2.6	0.4	4.9	0.2	4	0.2	3	0.2	2.6	
$t_{PLH}^{(2)}$	B	A	2.1	0.6	3.8	0.5	3.4	0.4	3	0.3	2.8	ns
$t_{PHL}^{(2)}$			2.1	0.6	3.8	0.5	3.4	0.4	3	0.3	2.8	
$t_{PHZ}^{(2)}$	DIR	A	2.4	0.7	7.9	0.8	6.4	0.8	5	0.5	4.3	ns
$t_{PLZ}^{(2)}$			2.4	0.7	7.9	0.8	6.4	0.8	5	0.5	4.3	
$t_{PHZ}^{(2)}$	DIR	B	3.8	1	4.3	0.6	4.3	0.5	4.2	1.1	4.1	ns
$t_{PLZ}^{(2)}$			3.8	1	4.3	0.6	4.3	0.5	4.2	1.1	4.1	
$t_{PZH}^{(2)(1)}$	DIR	A	5.9		8.5		7.7		7.2		6.9	ns
$t_{PZL}^{(2)(1)}$			5.9		8.5		7.7		7.2		6.9	
$t_{PZH}^{(2)(1)}$	DIR	B	5		12.8		10.4		8		6.9	ns
$t_{PZL}^{(2)(1)}$			5		12.8		10.4		8		6.9	

(1) The enable time is a calculated value, derived using the formula shown in the [Section 8.2.2.2.1](#) section.

(2) t_{PLH} : Low-to-high Propagation Delay; t_{PHL} : High-to-Low Propagation Delay; t_{PHZ} : High-to-Hi-Z Propagation Delay; t_{PLZ} : Low-to-Hi-Z Propagation Delay; t_{PZH} : Hi-Z-to-High Propagation Delay; t_{PZL} : Hi-Z-to-Low Propagation Delay

5.10 Switching Characteristics: $V_{CCA} = 3.3V \pm 0.3V$

over recommended operating free-air temperature range, $V_{CCA} = 3.3V \pm 0.3V$ (see Figure 6-1)

PARAMETER	FROM (INPUT)	TO (OUTPUT)	$V_{CCB} = 1.2V$	$V_{CCB} = 1.5V \pm 0.1V$		$V_{CCB} = 1.8V \pm 0.15V$		$V_{CCB} = 2.5V \pm 0.2V$		$V_{CCB} = 3.3V \pm 0.3V$		UNIT
			TYP	MIN	MAX	MIN	MAX	MIN	MAX	MIN	MAX	
$t_{PLH}^{(2)}$	A	B	2.5	0.3	4.7	0.2	3.8	0.2	2.8	0.2	2.4	ns
$t_{PHL}^{(2)}$			2.5	0.3	4.7	0.2	3.8	0.2	2.8	0.2	2.4	
$t_{PLH}^{(2)}$	B	A	2.1	0.6	3.6	0.4	3.1	0.3	2.6	0.3	2.4	ns
$t_{PHL}^{(2)}$			2.1	0.6	3.6	0.4	3.1	0.3	2.6	0.3	2.4	
$t_{PHZ}^{(2)}$	DIR	A	2.9	1.1	8	1	6.5	1.3	4.7	1.2	4	ns
$t_{PLZ}^{(2)}$			2.9	1.1	8	1	6.5	1.3	4.7	1.2	4	
$t_{PHZ}^{(2)}$	DIR	B	3.4	0.5	6.6	0.3	5.6	0.3	4.6	1.1	4.2	ns
$t_{PLZ}^{(2)}$			3.4	0.5	6.6	0.3	5.6	0.3	4.6	1.1	4.2	
$t_{PZH}^{(2)(1)}$	DIR	A	5.5		10.2		8.7		7.2		6.6	ns
$t_{PZL}^{(2)(1)}$			5.5		10.2		8.7		7.2		6.6	
$t_{PZH}^{(2)(1)}$	DIR	B	5.4		12.7		10.3		7.5		6.4	ns
$t_{PZL}^{(2)(1)}$			5.4		12.7		10.3		7.5		6.4	

- (1) The enable time is a calculated value, derived using the formula shown in the section
(2) t_{PLH} : Low-to-high Propagation Delay; t_{PHL} : High-to-Low Propagation Delay; t_{PHZ} : High-to-Hi-Z Propagation Delay; t_{PLZ} : Low-to-Hi-Z Propagation Delay; t_{PZH} : Hi-Z-to-High Propagation Delay; t_{PZL} : Hi-Z-to-Low Propagation Delay

5.11 Operating Characteristics

$T_A = 25^\circ C$

PARAMETER		TEST CONDITIONS	$V_{CCA} = V_{CCB} = 1.2V$	$V_{CCA} = V_{CCB} = 1.5V$	$V_{CCA} = V_{CCB} = 1.8V$	$V_{CCA} = V_{CCB} = 2.5V$	$V_{CCA} = V_{CCB} = 3.3V$	UNIT
			TYP	TYP	TYP	TYP	TYP	
$C_{pdA}^{(1)}$	A-port input, B-port output	$C_L = 0,$ $f = 10MHz,$ $t_r^{(2)} = t_f^{(2)} = 1ns$	3	3	3	3	4	pF
	B-port input, A-port output		12	13	13	14	15	
$C_{pdB}^{(1)}$	A-port input, B-port output	$C_L = 0,$ $f = 10MHz,$ $t_r^{(2)} = t_f^{(2)} = 1ns$	12	13	13	14	15	pF
	B-port input, A-port output		3	3	3	3	4	

- (1) Power-dissipation capacitance per transceiver
(2) t_r : Rise time; t_f : Fall time

5.12 Typical Characteristics

Table 5-1. Typical Total Static Power Consumption ($I_{CCA} + I_{CCB}$)

V_{CCB}	V_{CCA}						UNIT
	0V	1.2V	1.5V	1.8V	2.5V	3.3V	
0V	0	<0.5	<0.5	<0.5	<0.5	<0.5	μA
1.2V	<0.5	<1	<1	<1	<1	1	
1.5V	<0.5	<1	<1	<1	<1	1	
1.8V	<0.5	<1	<1	<1	<1	<1	
2.5V	<0.5	1	<1	<1	<1	<1	
3.3V	<0.5	1	<1	<1	<1	<1	

5.12.1 Typical Propagation Delay (A to B) vs Load Capacitance, $T_A = 25^\circ\text{C}$, $V_{CCA} = 1.2\text{V}$

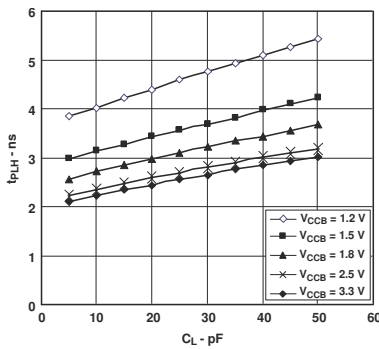

Figure 5-1. Typical A-to-B Propagation Delay, Low to High

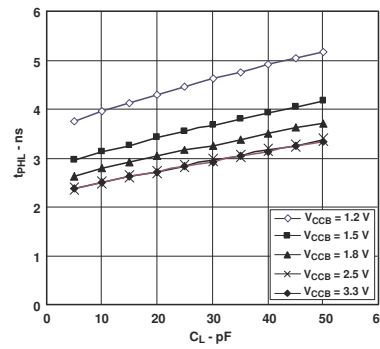

Figure 5-2. Typical A-to-B Propagation Delay, High to Low

5.12.2 Typical Propagation Delay (A to B) vs Load Capacitance, $T_A = 25^\circ\text{C}$, $V_{CCA} = 1.5\text{V}$

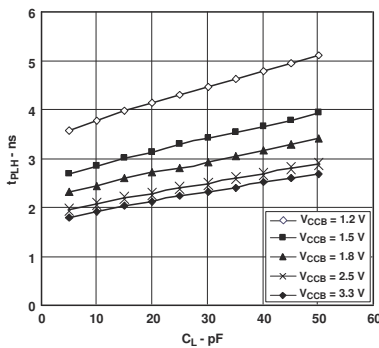

Figure 5-3. Typical A-to-B Propagation Delay, Low to High

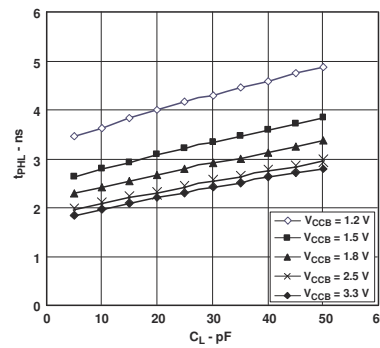

Figure 5-4. Typical A-to-B Propagation Delay, High to Low

5.12.3 Typical Propagation Delay (A-to-B) vs Load Capacitance, $T_A = 25^\circ\text{C}$, $V_{CCA} = 1.8\text{V}$

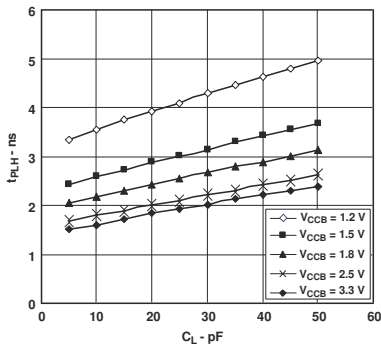

Figure 5-5. Typical A-to-B Propagation Delay, Low to High

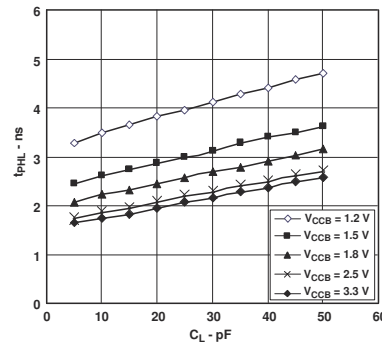

Figure 5-6. Typical A-to-B Propagation Delay, High to Low

5.12.4 Typical Propagation Delay (A to B) vs Load Capacitance, $T_A = 25^\circ\text{C}$, $V_{CCA} = 2.5\text{V}$

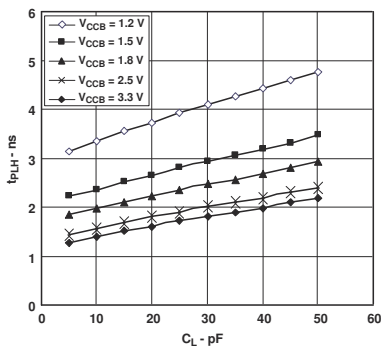

Figure 5-7. Typical A-to-B Propagation Delay, Low to High

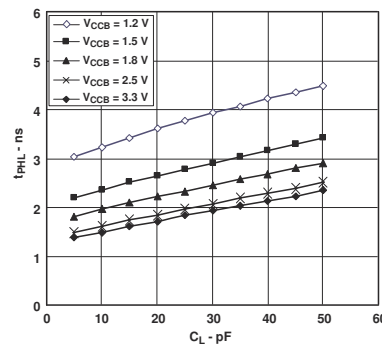

Figure 5-8. Typical A-to-B Propagation Delay, High to Low

5.12.5 Typical Propagation Delay (A to B) vs Load Capacitance, $T_A = 25^\circ\text{C}$, $V_{CCA} = 3.3\text{V}$

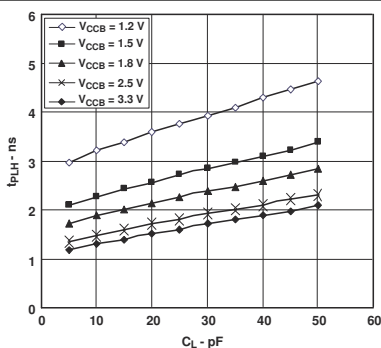

Figure 5-9. Typical A-to-B Propagation Delay, Low to High

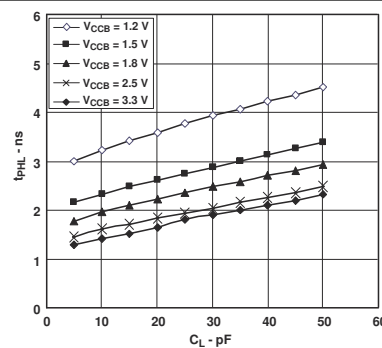
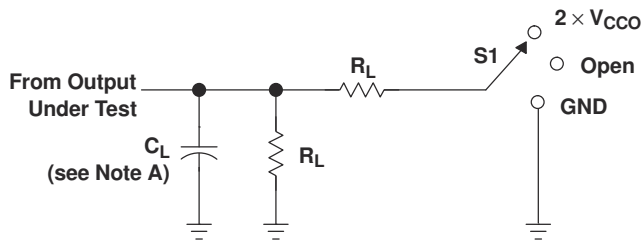

Figure 5-10. Typical A-to-B Propagation Delay, High to Low

6 Parameter Measurement Information



LOAD CIRCUIT

TEST	S1
t_{pd}	Open
t_{PLZ}/t_{PZL}	$2 \times V_{CCO}$
t_{PHZ}/t_{PZH}	GND

V_{CCO}	C_L	R_L	V_{TP}
1.2 V	15 pF	2 k Ω	0.1 V
1.5 V \pm 0.1 V	15 pF	2 k Ω	0.1 V
1.8 V \pm 0.15 V	15 pF	2 k Ω	0.15 V
2.5 V \pm 0.2 V	15 pF	2 k Ω	0.15 V
3.3 V \pm 0.3 V	15 pF	2 k Ω	0.3 V

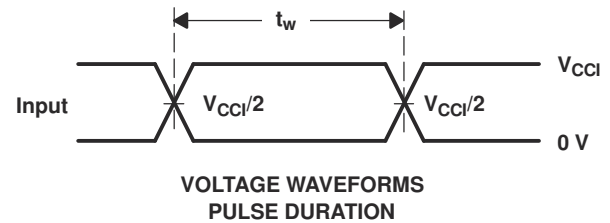

VOLTAGE WAVEFORMS
PULSE DURATION

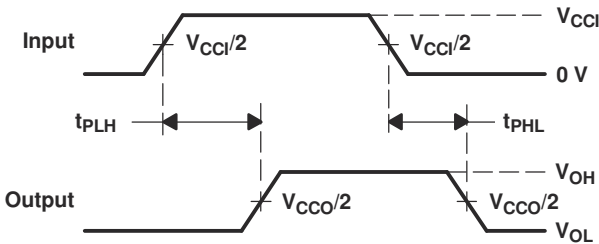

VOLTAGE WAVEFORMS
PROPAGATION DELAY TIMES

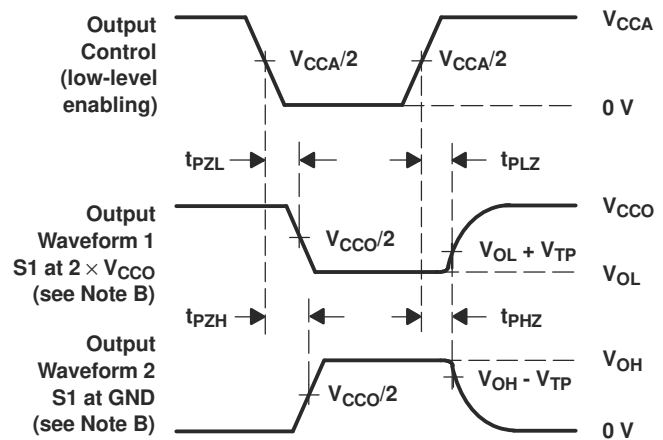

VOLTAGE WAVEFORMS
ENABLE AND DISABLE TIMES

- NOTES:
- A. C_L includes probe and jig capacitance.
 - B. Waveform 1 is for an output with internal conditions such that the output is low, except when disabled by the output control. Waveform 2 is for an output with internal conditions such that the output is high, except when disabled by the output control.
 - C. All input pulses are supplied by generators having the following characteristics: $PRR \leq 10$ MHz, $Z_O = 50 \Omega$, $dv/dt \geq 1$ V/ns.
 - D. The outputs are measured one at a time, with one transition per measurement.
 - E. t_{PLZ} and t_{PHZ} are the same as t_{dis} .
 - F. t_{PZL} and t_{PZH} are the same as t_{en} .
 - G. t_{PLH} and t_{PHL} are the same as t_{pd} .
 - H. V_{CC1} is the V_{CC} associated with the input port.
 - I. V_{CCO} is the V_{CC} associated with the output port.

Figure 6-1. Load Circuit and Voltage Waveforms

7 Detailed Description

7.1 Overview

This dual-bit noninverting bus transceiver uses two separate configurable power-supply rails. The A port is designed to track V_{CCA} and accepts any supply voltage from 1.2V to 3.6V. The B port is designed to track V_{CCB} and accepts any supply voltage from 1.2V to 3.6V. This allows for universal low-voltage bidirectional translation and level-shifting between any of the 1.2V, 1.5V, 1.8V, 2.5V, and 3.3V voltage nodes.

The device is designed for asynchronous communication between two data buses. The logic levels of the direction-control (DIR) input activate either the B-port outputs or the A-port outputs. The device transmits data from the A bus to the B bus when the B-port outputs are activated and from the B bus to the A bus when the A-port outputs are activated. The input circuitry on both A and B ports always is active and must have a logic HIGH or LOW level applied to prevent excess internal leakage of the CMOS.

The device is designed so that the DIR input is powered by supply voltage from V_{CCA} .

This device is fully specified for partial-power-down applications using off output current (I_{off}). The I_{off} circuitry disables the outputs, preventing damaging current backflow through the device when powered down.

The V_{CC} isolation feature makes sure that if either VCC input is at GND, both ports are put in a high-impedance state. This action prevents a false high or low logic being presented at the output.

NanoFree package technology is a major breakthrough in IC packaging concepts, using the die as the package.

7.2 Functional Block Diagram

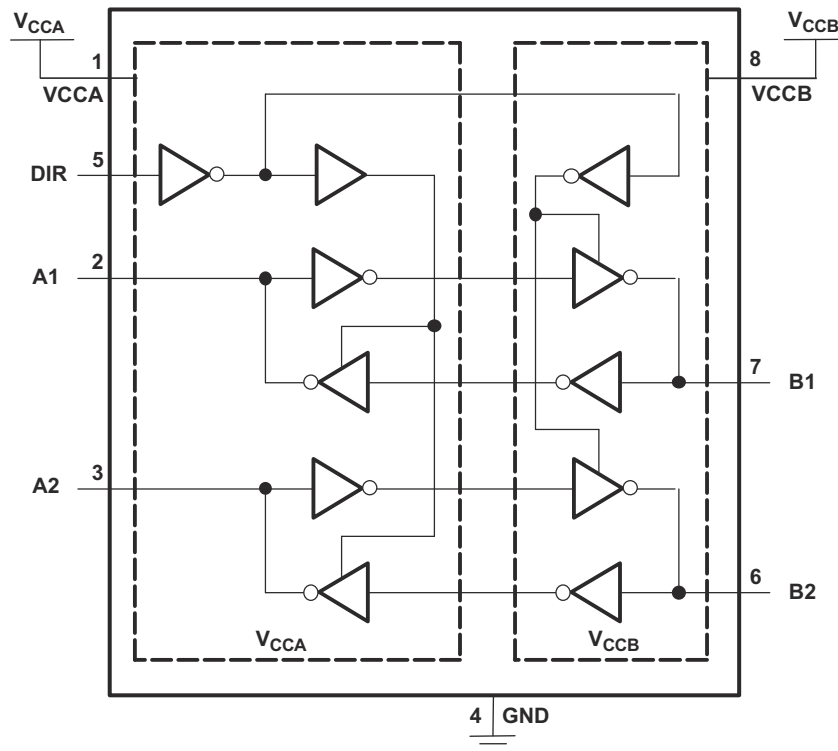

Pin numbers are for the DCT and DCU packages only.

7.3 Feature Description

7.3.1 VCC Isolation

The V_{CC} isolation feature make sure that if either V_{CCA} or V_{CCB} are at GND, both ports are in a high-impedance state (I_{OZ} shown in [Electrical Characteristics](#)). This action prevents false logic levels from being presented to either bus.

7.3.2 2-Rail Design

Fully configurable 2-rail design allows each port to operate over the full 1.2V to 3.6V power-supply range.

7.3.3 IO Ports are 4.6-V Tolerant

The IO ports are up to 4.6 V tolerant.

7.3.4 Partial-Power-Down Mode

This device is fully specified for partial-power-down applications using off output current (I_{off}). The I_{off} circuitry disables the outputs, preventing damaging current backflow through the device when the device is powered down.

7.4 Device Functional Modes

[Table 7-1](#) shows the functional modes of the SN74AVC2T45-Q1.

**Table 7-1. Function Table
(Each Transceiver)**

INPUT DIR	OPERATION
L	B data to A bus
H	A data to B bus

8 Application and Implementation

Note

Information in the following applications sections is not part of the TI component specification, and TI does not warrant its accuracy or completeness. TI's customers are responsible for determining suitability of components for their purposes. Customers should validate and test their design implementation to confirm system functionality.

8.1 Application Information

The SN74AVC2T45 is used to shift IO voltage levels from one voltage domain to another. Bus A and bus B have independent power supplies, and a direction pin is used to control the direction of data flow. Unused data ports must not be floating; tie the unused port input and output to ground directly.

8.2 Typical Applications

8.2.1 Unidirectional Logic Level-Shifting Application

Figure 8-1 is an example circuit of the SN74AVC2T45 used in a unidirectional logic level-shifting application.

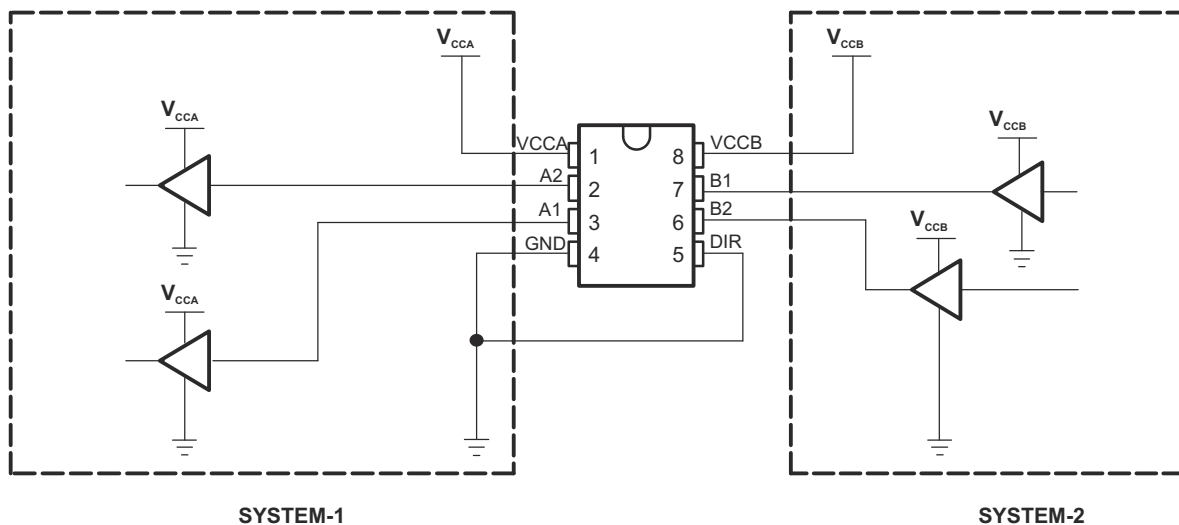

Figure 8-1. Unidirectional Logic Level-Shifting Application

8.2.1.1 Design Requirements

Table 8-1 lists the pins and pin descriptions of the SN74AVC2T45 connections with SYSTEM-1 and SYSTEM-2.

Table 8-1. SN74AVC2T45 Pin Connections With SYSTEM-1 and SYSTEM-2

PIN	NAME	DESCRIPTION
1	VCCA	SYSTEM-1 supply voltage (1.2V to 3.6V)
2	A1	Output level depends on V_{CCA} .
3	A2	Output level depends on V_{CCA} .
4	GND	Device GND
5	DIR	The GND (low-level) determines B-port to A-port direction.
6	B2	Input threshold value depends on V_{CCB} .
7	B1	Input threshold value depends on V_{CCB} .
8	VCCB	SYSTEM-2 supply voltage (1.2V to 3.6V)

SN74AVC2T45

SCES531N – DECEMBER 2003 – REVISED FEBRUARY 2025

8.2.1.2 Detailed Design Procedure

This device uses drivers which are enabled depending on the state of the DIR pin. The designer must know the intended flow of data and take care not to violate any of the high or low logic levels. Unused data inputs must not be floating, as this can cause excessive internal leakage on the input CMOS structure. Make sure to tie any unused input and output ports directly to ground.

8.2.1.3 Application Curve

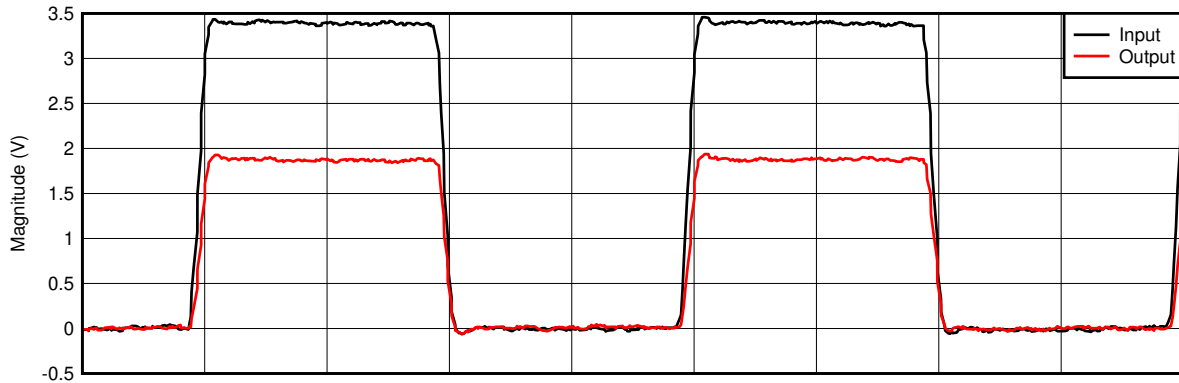

D001

Figure 8-2. 3.3 V to 1.8 V Level-Shifting With 1-MHz Square Wave

8.2.2 Bidirectional Logic Level-Shifting Application

Figure 8-3 shows the SN74AVC2T45 used in a bidirectional logic level-shifting application.

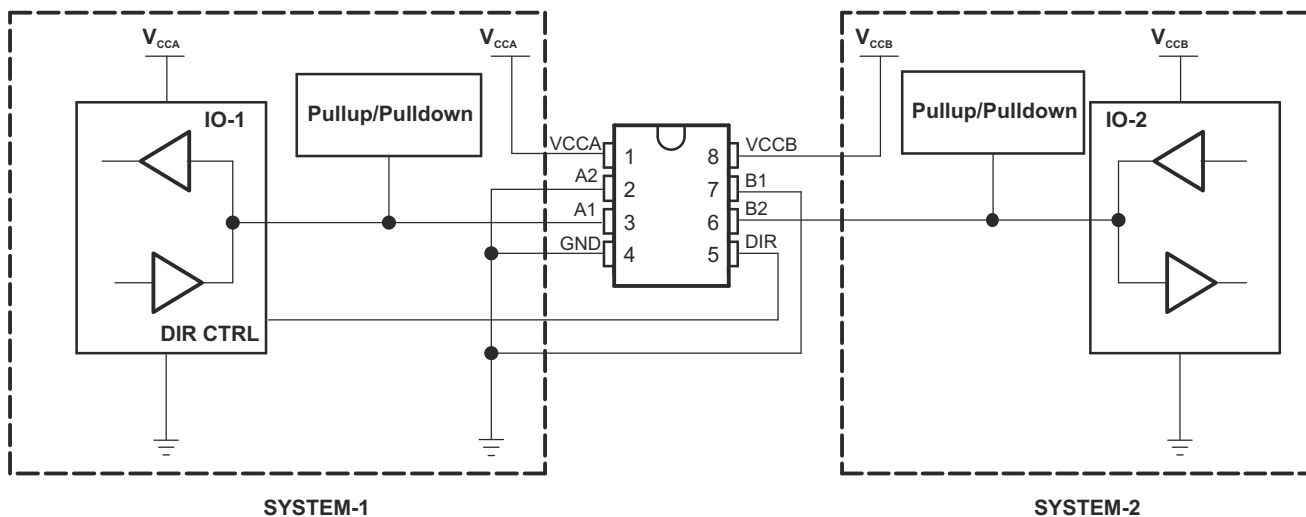

Figure 8-3. Bidirectional Logic Level-Shifting Application

8.2.2.1 Design Requirements

The SN74AVC2T45 does not have an output-enable (OE) pin, the system designer must take precautions to avoid bus contention between SYSTEM-1 and SYSTEM-2 when changing directions.

8.2.2.2 Detailed Design Procedure

Table 8-2 shows a sequence that illustrates data transmission from SYSTEM-1 to SYSTEM-2 and then from SYSTEM-2 to SYSTEM-1.

Table 8-2. Data Transmission Sequence

STATE	DIR CTRL	IO-1	IO-2	DESCRIPTION
1	H	Output	Input	SYSTEM-1 data to SYSTEM-2
2	H	Hi-Z	Hi-Z	SYSTEM-2 is getting ready to send data to SYSTEM-1. IO-1 and IO-2 are disabled. The bus-line state depends on pullup or pulldown. ⁽¹⁾
3	L	Hi-Z	Hi-Z	DIR bit is flipped. IO-1 and IO-2 still are disabled. The bus-line state depends on pullup or pulldown. ⁽¹⁾
4	L	Input	Output	SYSTEM-2 data to SYSTEM-1

(1) SYSTEM-1 and SYSTEM-2 must use the same conditions, that is, both pullup or both pulldown.

8.2.2.2.1 Enable Times

Calculate the enable times for the SN74AVC2T45 using the following formulas:

- $t_{PZH} \text{ (DIR to A)} = t_{PLZ} \text{ (DIR to B)} + t_{PLH} \text{ (B to A)}$
- $t_{PZL} \text{ (DIR to A)} = t_{PHZ} \text{ (DIR to B)} + t_{PHL} \text{ (B to A)}$
- $t_{PZH} \text{ (DIR to B)} = t_{PLZ} \text{ (DIR to A)} + t_{PLH} \text{ (A to B)}$
- $t_{PZL} \text{ (DIR to B)} = t_{PHZ} \text{ (DIR to A)} + t_{PHL} \text{ (A to B)}$

In a bidirectional application, these enable times provide the maximum delay from the time the DIR bit is switched until an output is expected. For example, if the SN74AVC2T45 initially is transmitting from A to B, then the DIR bit is switched; the B port of the device must be disabled before presenting the device with an input. After the B port has been disabled, an input signal applied to the port appears on the corresponding A port after the specified propagation delay.

8.3 Power Supply Recommendations

A proper power-up sequence must always be followed to avoid excessive current on the supply pin, bus contention, oscillations, or other anomalies. To guard against such power-up problems, take the following precautions:

1. Connect ground before any supply voltage is applied.
2. Power up V_{CCA} .
3. V_{CCB} can be ramped up along with or after V_{CCA} .

8.4 Layout

8.4.1 Layout Guidelines

To verify the reliability of the device, follow common printed-circuit board layout guidelines.

- Bypass capacitors can be used on power supplies. Place the capacitors as close as possible to the VCCA, VCCB pin and GND pin.
- Short trace lengths can be used to avoid excessive loading.

8.4.2 Layout Example

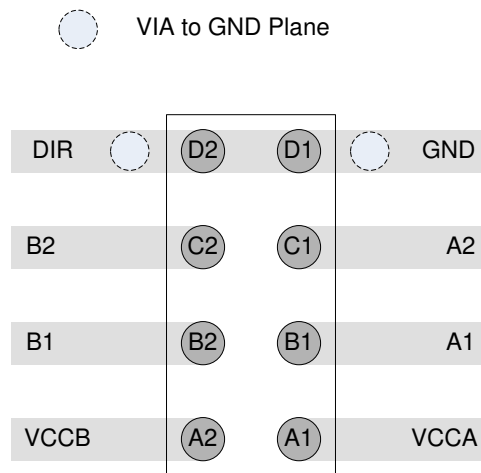

Figure 8-4. Layout Example for YZP Package

9 Device and Documentation Support

9.1 Documentation Support

9.1.1 Related Documentation

For related documentation see the following:

- Texas Instruments, [Implications of Slow or Floating CMOS Inputs](#)

9.2 Receiving Notification of Documentation Updates

To receive notification of documentation updates, navigate to the device product folder on ti.com. Click on *Notifications* to register and receive a weekly digest of any product information that has changed. For change details, review the revision history included in any revised document.

9.3 Support Resources

[TI E2E™ support forums](#) are an engineer's go-to source for fast, verified answers and design help — straight from the experts. Search existing answers or ask your own question to get the quick design help you need.

Linked content is provided "AS IS" by the respective contributors. They do not constitute TI specifications and do not necessarily reflect TI's views; see TI's [Terms of Use](#).

9.4 Trademarks

NanoFree™ is a trademark of Texas Instruments.

TI E2E™ is a trademark of Texas Instruments.

All trademarks are the property of their respective owners.

9.5 Electrostatic Discharge Caution



This integrated circuit can be damaged by ESD. Texas Instruments recommends that all integrated circuits be handled with appropriate precautions. Failure to observe proper handling and installation procedures can cause damage.

ESD damage can range from subtle performance degradation to complete device failure. Precision integrated circuits may be more susceptible to damage because very small parametric changes could cause the device not to meet its published specifications.

9.6 Glossary

[TI Glossary](#) This glossary lists and explains terms, acronyms, and definitions.

10 Revision History

NOTE: Page numbers for previous revisions may differ from page numbers in the current version.

Changes from Revision M (September 2024) to Revision N (February 2025) Page

- | | |
|--|---|
| • Updated DCT and DDF <i>Thermal Information</i> | 6 |
|--|---|

Changes from Revision L (May 2017) to Revision M (September 2024) Page

- | | |
|--|----|
| • Updated the numbering format for tables, figures, and cross-references throughout the document..... | 1 |
| • Added DDF package..... | 1 |
| • Deleted the <i>Community Resources</i> section | 19 |
| • Added the <i>Support Resources, Receiving Notification of Documentation Updates, Electrostatic Discharge Statement, and Glossary</i> sections..... | 19 |

Changes from Revision K (April 2015) to Revision L (May 2017)	Page
• Changed data sheet title.....	1
• Changed YZP package pinout diagram to bottom view.....	3
• Added Type column to <i>Pin Functions</i> table	3
• Added Junction temperature, T_J	4

Changes from Revision J (June 2007) to Revision K (April 2015)	Page
• Added <i>Pin Configuration and Functions</i> section, <i>ESD Ratings</i> table, <i>Feature Description</i> section, <i>Device Functional Modes</i> , <i>Application and Implementation</i> section, <i>Power Supply Recommendations</i> section, <i>Layout</i> section, <i>Device and Documentation Support</i> section, and <i>Mechanical, Packaging, and Orderable Information</i> section	1

11 Mechanical, Packaging, and Orderable Information

The following pages include mechanical, packaging, and orderable information. This information is the most current data available for the designated devices. This data is subject to change without notice and revision of this document. For browser-based versions of this data sheet, refer to the left-hand navigation.

PACKAGING INFORMATION

Orderable part number	Status (1)	Material type (2)	Package Pins	Package qty Carrier	RoHS (3)	Lead finish/ Ball material (4)	MSL rating/ Peak reflow (5)	Op temp (°C)	Part marking (6)
SN74AVC2T45DCTR	Active	Production	SSOP (DCT) 8	3000 LARGE T&R	Yes	NIPDAU SN	Level-1-260C-UNLIM	-40 to 85	DT2 Z
SN74AVC2T45DCTR.A	Active	Production	SSOP (DCT) 8	3000 LARGE T&R	Yes	NIPDAU	Level-1-260C-UNLIM	-40 to 85	DT2 Z
SN74AVC2T45DCTR.B	Active	Production	SSOP (DCT) 8	3000 LARGE T&R	Yes	NIPDAU	Level-1-260C-UNLIM	-40 to 85	DT2 Z
SN74AVC2T45DCTRE4	Active	Production	SSOP (DCT) 8	3000 LARGE T&R	Yes	NIPDAU	Level-1-260C-UNLIM	-40 to 85	DT2 Z
SN74AVC2T45DCTRG4	Active	Production	SSOP (DCT) 8	3000 LARGE T&R	Yes	NIPDAU	Level-1-260C-UNLIM	-40 to 125	DT2 Z
SN74AVC2T45DCTRG4.A	Active	Production	SSOP (DCT) 8	3000 LARGE T&R	Yes	NIPDAU	Level-1-260C-UNLIM	-40 to 125	DT2 Z
SN74AVC2T45DCTRG4.B	Active	Production	SSOP (DCT) 8	3000 LARGE T&R	Yes	NIPDAU	Level-1-260C-UNLIM	-40 to 125	DT2 Z
SN74AVC2T45DCTT	Active	Production	SSOP (DCT) 8	250 SMALL T&R	Yes	NIPDAU	Level-1-260C-UNLIM	-40 to 85	DT2 Z
SN74AVC2T45DCTT.B	Active	Production	SSOP (DCT) 8	250 SMALL T&R	Yes	NIPDAU	Level-1-260C-UNLIM	-40 to 85	DT2 Z
SN74AVC2T45DCUR	Active	Production	VSSOP (DCU) 8	3000 LARGE T&R	Yes	NIPDAU SN	Level-1-260C-UNLIM	-40 to 85	(DT2R, T2) DZ
SN74AVC2T45DCUR.A	Active	Production	VSSOP (DCU) 8	3000 LARGE T&R	Yes	SN	Level-1-260C-UNLIM	-40 to 85	(DT2R, T2) DZ
SN74AVC2T45DCUR.B	Active	Production	VSSOP (DCU) 8	3000 LARGE T&R	Yes	SN	Level-1-260C-UNLIM	-40 to 85	(DT2R, T2) DZ
SN74AVC2T45DCURG4	Active	Production	VSSOP (DCU) 8	3000 LARGE T&R	Yes	NIPDAU	Level-1-260C-UNLIM	-40 to 85	DT2R
SN74AVC2T45DCURG4.A	Active	Production	VSSOP (DCU) 8	3000 LARGE T&R	Yes	NIPDAU	Level-1-260C-UNLIM	-40 to 85	DT2R
SN74AVC2T45DCURG4.B	Active	Production	VSSOP (DCU) 8	3000 LARGE T&R	Yes	NIPDAU	Level-1-260C-UNLIM	-40 to 85	DT2R
SN74AVC2T45DCUT	Active	Production	VSSOP (DCU) 8	250 SMALL T&R	Yes	NIPDAU	Level-1-260C-UNLIM	-40 to 85	DT2R
SN74AVC2T45DCUT.B	Active	Production	VSSOP (DCU) 8	250 SMALL T&R	Yes	NIPDAU	Level-1-260C-UNLIM	-40 to 85	DT2R
SN74AVC2T45DCUTG4	Active	Production	VSSOP (DCU) 8	250 SMALL T&R	Yes	NIPDAU	Level-1-260C-UNLIM	-40 to 85	DT2R
SN74AVC2T45DCUTG4.B	Active	Production	VSSOP (DCU) 8	250 SMALL T&R	Yes	NIPDAU	Level-1-260C-UNLIM	-40 to 85	DT2R
SN74AVC2T45DDFR	Active	Production	SOT-23-THIN (DDF) 8	3000 LARGE T&R	Yes	SN	Level-1-260C-UNLIM	-40 to 125	A2T45

Orderable part number	Status (1)	Material type (2)	Package Pins	Package qty Carrier	RoHS (3)	Lead finish/ Ball material (4)	MSL rating/ Peak reflow (5)	Op temp (°C)	Part marking (6)
SN74AVC2T45DDFR.A	Active	Production	SOT-23-THIN (DDF) 8	3000 LARGE T&R	Yes	SN	Level-1-260C-UNLIM	-40 to 125	A2T45
SN74AVC2T45YZPR	Active	Production	DSBGA (YZP) 8	3000 LARGE T&R	Yes	SNAGCU	Level-1-260C-UNLIM	-40 to 85	TDN
SN74AVC2T45YZPR.B	Active	Production	DSBGA (YZP) 8	3000 LARGE T&R	Yes	SNAGCU	Level-1-260C-UNLIM	-40 to 85	TDN

(1) **Status:** For more details on status, see our [product life cycle](#).

(2) **Material type:** When designated, preproduction parts are prototypes/experimental devices, and are not yet approved or released for full production. Testing and final process, including without limitation quality assurance, reliability performance testing, and/or process qualification, may not yet be complete, and this item is subject to further changes or possible discontinuation. If available for ordering, purchases will be subject to an additional waiver at checkout, and are intended for early internal evaluation purposes only. These items are sold without warranties of any kind.

(3) **RoHS values:** Yes, No, RoHS Exempt. See the [TI RoHS Statement](#) for additional information and value definition.

(4) **Lead finish/Ball material:** Parts may have multiple material finish options. Finish options are separated by a vertical ruled line. Lead finish/Ball material values may wrap to two lines if the finish value exceeds the maximum column width.

(5) **MSL rating/Peak reflow:** The moisture sensitivity level ratings and peak solder (reflow) temperatures. In the event that a part has multiple moisture sensitivity ratings, only the lowest level per JEDEC standards is shown. Refer to the shipping label for the actual reflow temperature that will be used to mount the part to the printed circuit board.

(6) **Part marking:** There may be an additional marking, which relates to the logo, the lot trace code information, or the environmental category of the part.

Multiple part markings will be inside parentheses. Only one part marking contained in parentheses and separated by a "-" will appear on a part. If a line is indented then it is a continuation of the previous line and the two combined represent the entire part marking for that device.

Important Information and Disclaimer: The information provided on this page represents TI's knowledge and belief as of the date that it is provided. TI bases its knowledge and belief on information provided by third parties, and makes no representation or warranty as to the accuracy of such information. Efforts are underway to better integrate information from third parties. TI has taken and continues to take reasonable steps to provide representative and accurate information but may not have conducted destructive testing or chemical analysis on incoming materials and chemicals. TI and TI suppliers consider certain information to be proprietary, and thus CAS numbers and other limited information may not be available for release.

In no event shall TI's liability arising out of such information exceed the total purchase price of the TI part(s) at issue in this document sold by TI to Customer on an annual basis.

OTHER QUALIFIED VERSIONS OF SN74AVC2T45 :

- Automotive : [SN74AVC2T45-Q1](#)

NOTE: Qualified Version Definitions:

- Automotive - Q100 devices qualified for high-reliability automotive applications targeting zero defects

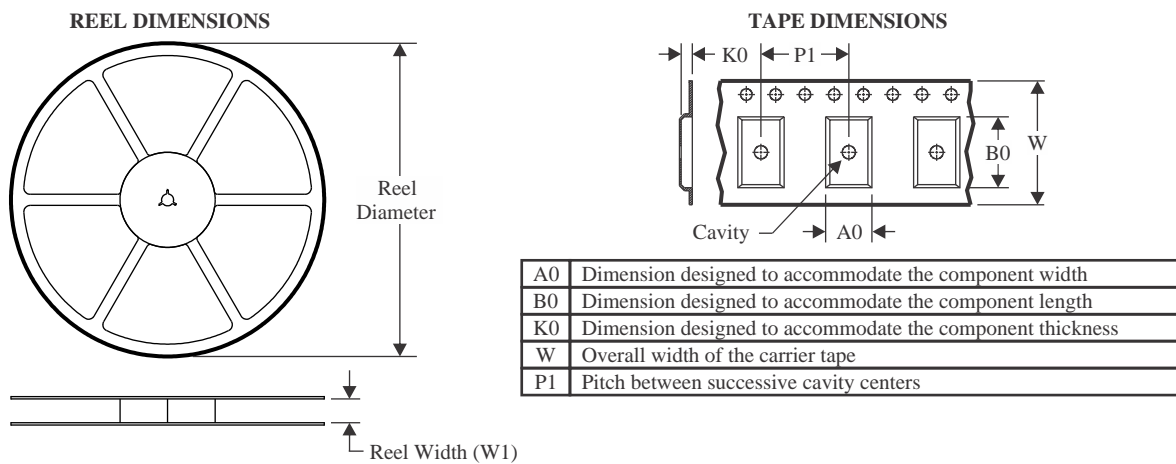
TAPE AND REEL INFORMATION

QUADRANT ASSIGNMENTS FOR PIN 1 ORIENTATION IN TAPE



*All dimensions are nominal

Device	Package Type	Package Drawing	Pins	SPQ	Reel Diameter (mm)	Reel Width W1 (mm)	A0 (mm)	B0 (mm)	K0 (mm)	P1 (mm)	W (mm)	Pin1 Quadrant
SN74AVC2T45DCTR	SSOP	DCT	8	3000	180.0	12.4	3.15	4.35	1.55	4.0	12.0	Q3
SN74AVC2T45DCTRG4	SSOP	DCT	8	3000	180.0	13.0	3.35	4.5	1.55	4.0	12.0	Q3
SN74AVC2T45DCTT	SSOP	DCT	8	250	180.0	13.0	3.35	4.5	1.55	4.0	12.0	Q3
SN74AVC2T45DCUR	VSSOP	DCU	8	3000	180.0	9.0	2.25	3.4	1.0	4.0	8.0	Q3
SN74AVC2T45DCURG4	VSSOP	DCU	8	3000	180.0	8.4	2.25	3.35	1.05	4.0	8.0	Q3
SN74AVC2T45DCUTG4	VSSOP	DCU	8	250	180.0	8.4	2.25	3.35	1.05	4.0	8.0	Q3
SN74AVC2T45DDFR	SOT-23-THIN	DDF	8	3000	180.0	8.4	3.2	3.1	1.25	4.0	8.0	Q3
SN74AVC2T45YZPR	DSBGA	YZP	8	3000	178.0	9.2	1.02	2.02	0.63	4.0	8.0	Q1

TAPE AND REEL BOX DIMENSIONS

*All dimensions are nominal

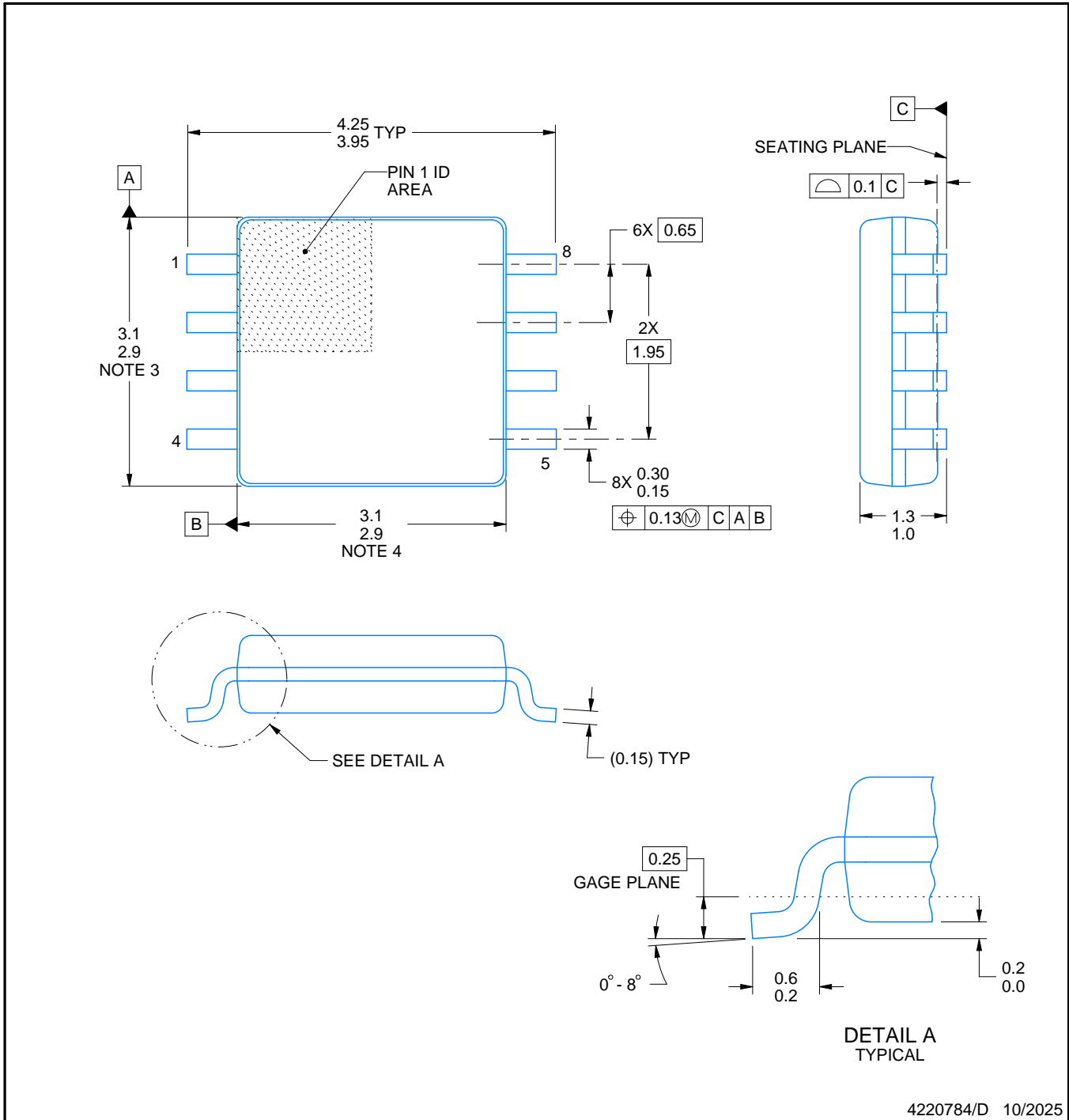
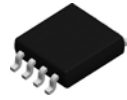
Device	Package Type	Package Drawing	Pins	SPQ	Length (mm)	Width (mm)	Height (mm)
SN74AVC2T45DCTR	SSOP	DCT	8	3000	190.0	190.0	30.0
SN74AVC2T45DCTRG4	SSOP	DCT	8	3000	182.0	182.0	20.0
SN74AVC2T45DCTT	SSOP	DCT	8	250	182.0	182.0	20.0
SN74AVC2T45DCUR	VSSOP	DCU	8	3000	182.0	182.0	20.0
SN74AVC2T45DCURG4	VSSOP	DCU	8	3000	202.0	201.0	28.0
SN74AVC2T45DCUTG4	VSSOP	DCU	8	250	202.0	201.0	28.0
SN74AVC2T45DDFR	SOT-23-THIN	DDF	8	3000	210.0	185.0	35.0
SN74AVC2T45YZPR	DSBGA	YZP	8	3000	220.0	220.0	35.0



4220784/D 10/2025

NOTES:

1. All linear dimensions are in millimeters. Dimensions in parenthesis are for reference only. Dimensioning and tolerancing per ASME Y14.5M.
2. This drawing is subject to change without notice.
3. This dimension does not include mold flash, protrusions, or gate burrs. Mold flash, protrusions, or gate burrs shall not exceed 0.15 mm per side.
4. This dimension does not include interlead flash. Interlead flash shall not exceed 0.25 mm per side.

EXAMPLE BOARD LAYOUT

DCT0008A

SSOP - 1.3 mm max height

SMALL OUTLINE PACKAGE

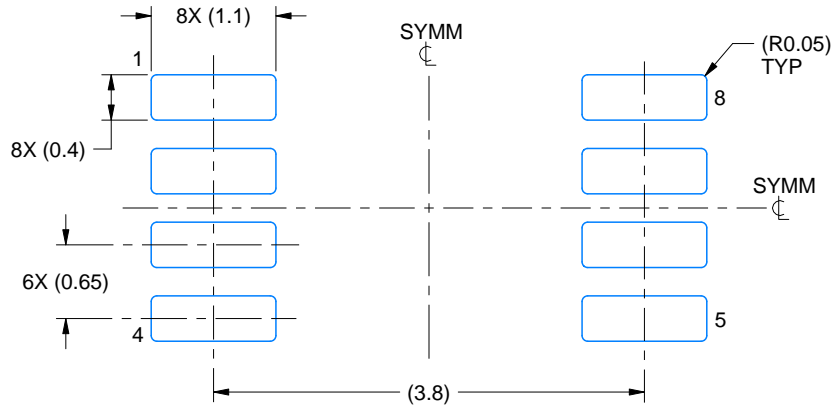

LAND PATTERN EXAMPLE
EXPOSED METAL SHOWN
SCALE:15X

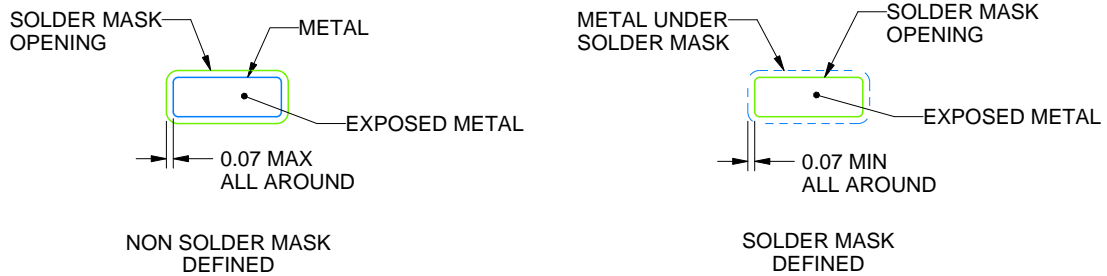

SOLDER MASK DETAILS

4220784/D 10/2025

NOTES: (continued)

- 5. Publication IPC-7351 may have alternate designs.
- 6. Solder mask tolerances between and around signal pads can vary based on board fabrication site.

EXAMPLE STENCIL DESIGN

DCT0008A

SSOP - 1.3 mm max height

SMALL OUTLINE PACKAGE

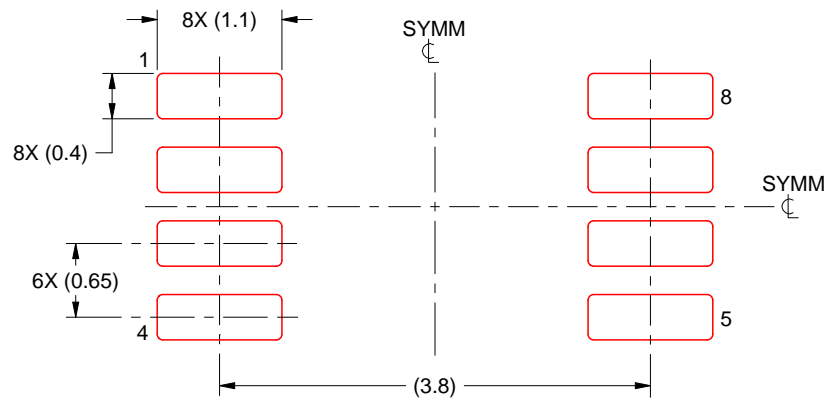

SOLDER PASTE EXAMPLE
BASED ON 0.125 mm THICK STENCIL
SCALE:15X

4220784/D 10/2025

NOTES: (continued)

7. Laser cutting apertures with trapezoidal walls and rounded corners may offer better paste release. IPC-7525 may have alternate design recommendations.
8. Board assembly site may have different recommendations for stencil design.

DCU0008A



PACKAGE OUTLINE

VSSOP - 0.9 mm max height

SMALL OUTLINE PACKAGE

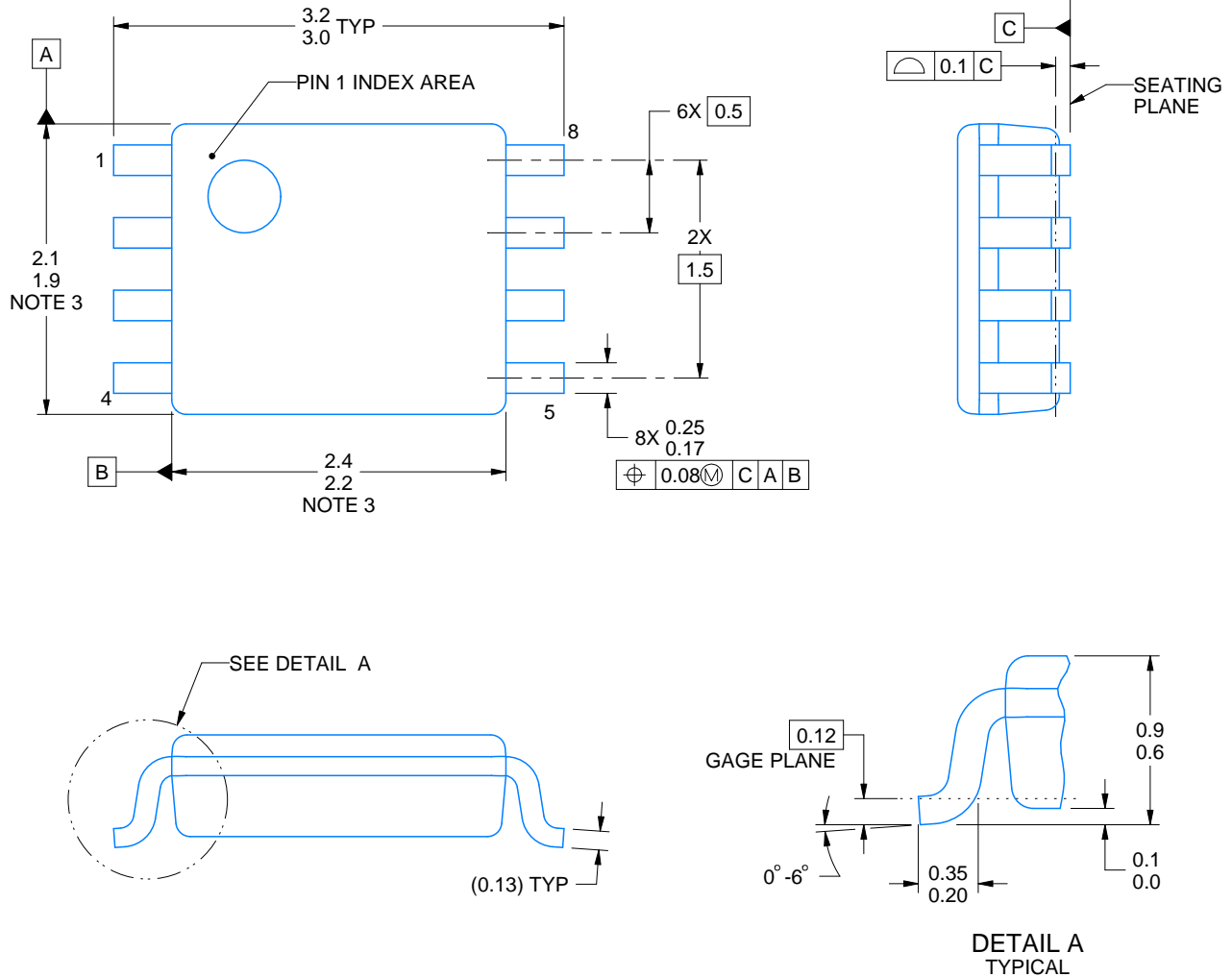

4225266/A 09/2014

NOTES:

1. All linear dimensions are in millimeters. Any dimensions in parenthesis are for reference only. Dimensioning and tolerancing per ASME Y14.5M.
2. This drawing is subject to change without notice.
3. This dimension does not include mold flash, protrusions, or gate burrs. Mold flash, protrusions, or gate burrs shall not exceed 0.15 mm per side.
4. Reference JEDEC registration MO-187 variation CA.

EXAMPLE BOARD LAYOUT

DCU0008A

VSSOP - 0.9 mm max height

SMALL OUTLINE PACKAGE

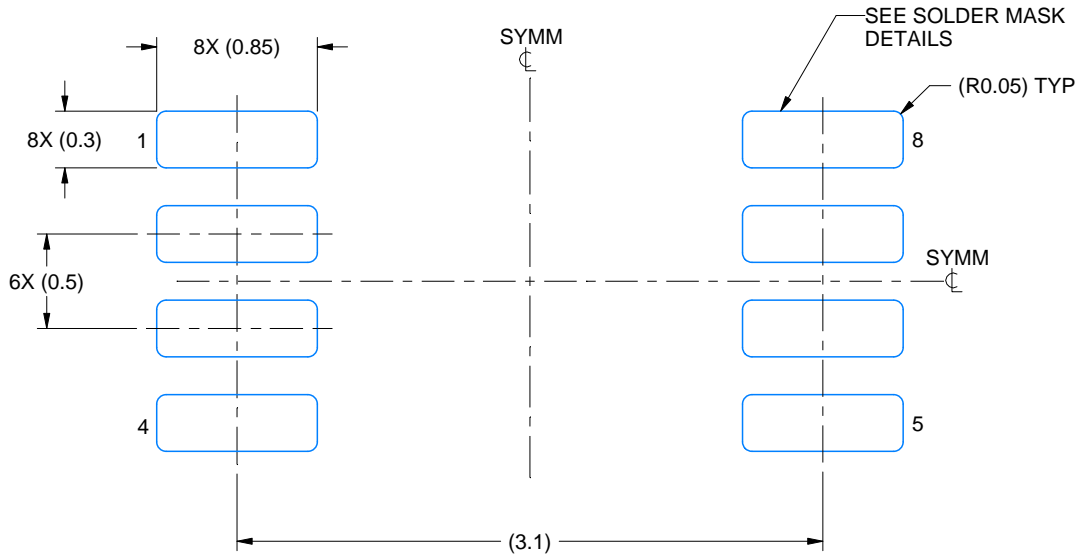

LAND PATTERN EXAMPLE
EXPOSED METAL SHOWN
SCALE: 25X



4225266/A 09/2014

NOTES: (continued)

- 5. Publication IPC-7351 may have alternate designs.
- 6. Solder mask tolerances between and around signal pads can vary based on board fabrication site.

EXAMPLE STENCIL DESIGN

DCU0008A

VSSOP - 0.9 mm max height

SMALL OUTLINE PACKAGE



SOLDER PASTE EXAMPLE
BASED ON 0.125 mm THICK STENCIL
SCALE: 25X

4225266/A 09/2014

NOTES: (continued)

7. Laser cutting apertures with trapezoidal walls and rounded corners may offer better paste release. IPC-7525 may have alternate design recommendations.
8. Board assembly site may have different recommendations for stencil design.

EXAMPLE BOARD LAYOUT

DDF0008A

SOT-23-THIN - 1.1 mm max height

PLASTIC SMALL OUTLINE

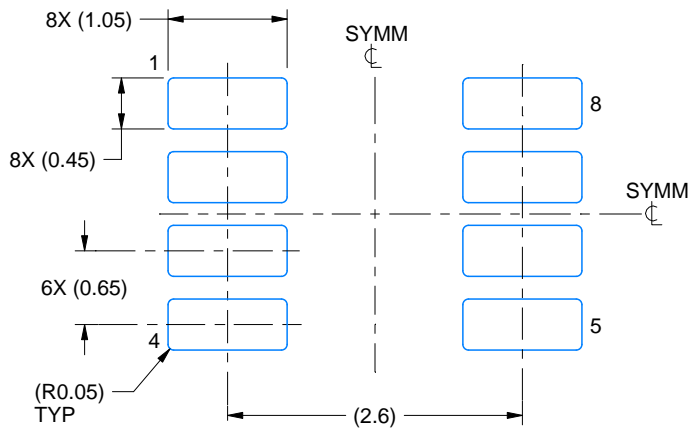

LAND PATTERN EXAMPLE
EXPOSED METAL SHOWN
SCALE:15X

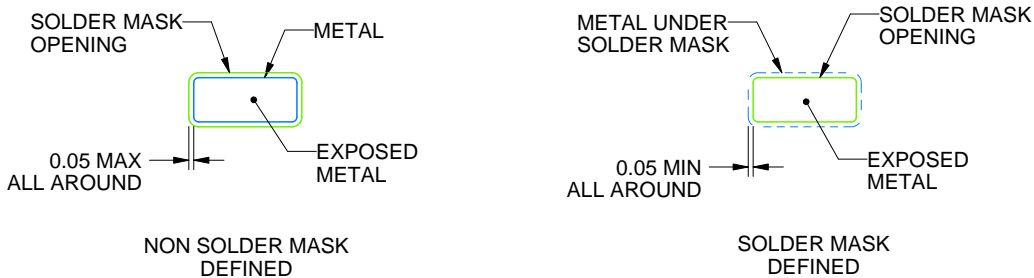

SOLDER MASK DETAILS

4222047/E 07/2024

NOTES: (continued)

- 4. Publication IPC-7351 may have alternate designs.
- 5. Solder mask tolerances between and around signal pads can vary based on board fabrication site.

EXAMPLE STENCIL DESIGN

DDF0008A

SOT-23-THIN - 1.1 mm max height

PLASTIC SMALL OUTLINE



SOLDER PASTE EXAMPLE
BASED ON 0.125 mm THICK STENCIL
SCALE:15X

4222047/E 07/2024

NOTES: (continued)

6. Laser cutting apertures with trapezoidal walls and rounded corners may offer better paste release. IPC-7525 may have alternate design recommendations.
7. Board assembly site may have different recommendations for stencil design.

YZP0008

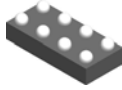

PACKAGE OUTLINE

DSBGA - 0.5 mm max height

DIE SIZE BALL GRID ARRAY

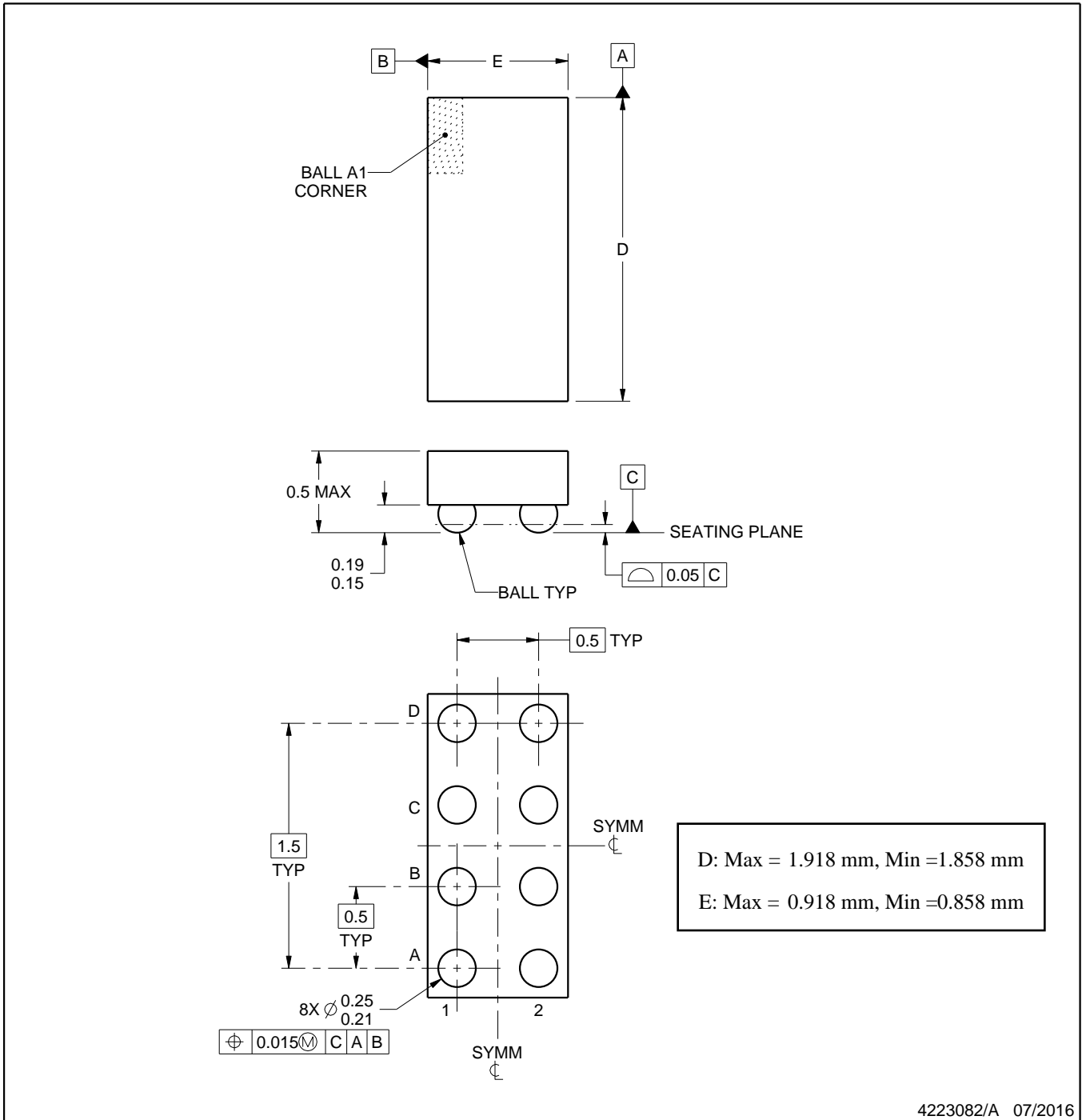

NOTES:

1. All linear dimensions are in millimeters. Any dimensions in parenthesis are for reference only. Dimensioning and tolerancing per ASME Y14.5M.
2. This drawing is subject to change without notice.

EXAMPLE BOARD LAYOUT

YZP0008

DSBGA - 0.5 mm max height

DIE SIZE BALL GRID ARRAY

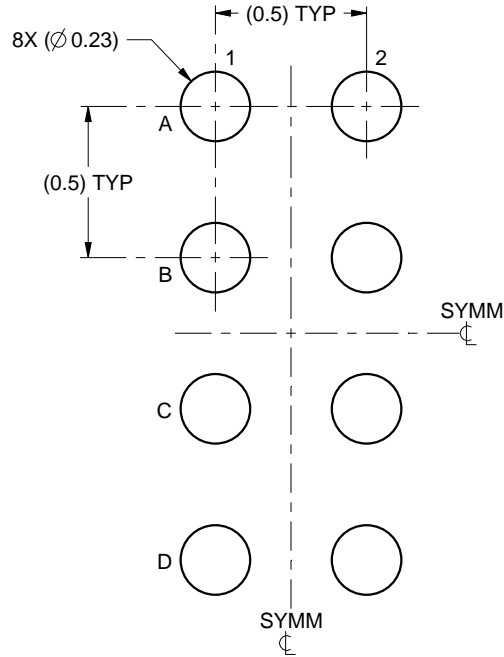

LAND PATTERN EXAMPLE
SCALE:40X

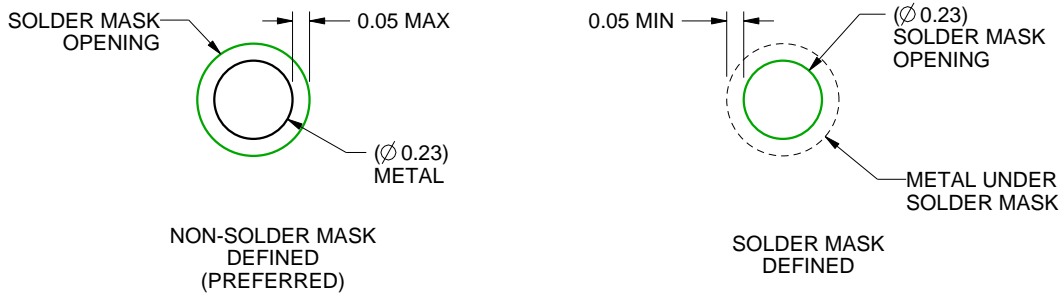

SOLDER MASK DETAILS
NOT TO SCALE

4223082/A 07/2016

NOTES: (continued)

3. Final dimensions may vary due to manufacturing tolerance considerations and also routing constraints. For more information, see Texas Instruments literature number SNVA009 (www.ti.com/lit/snva009).

EXAMPLE STENCIL DESIGN

YZP0008

DSBGA - 0.5 mm max height

DIE SIZE BALL GRID ARRAY

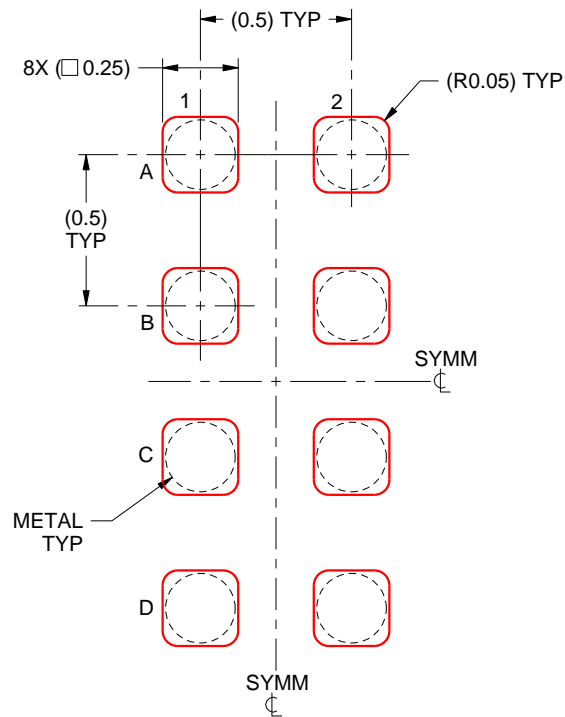

SOLDER PASTE EXAMPLE
BASED ON 0.1 mm THICK STENCIL
SCALE:40X

4223082/A 07/2016

NOTES: (continued)

4. Laser cutting apertures with trapezoidal walls and rounded corners may offer better paste release.

IMPORTANT NOTICE AND DISCLAIMER

TI PROVIDES TECHNICAL AND RELIABILITY DATA (INCLUDING DATASHEETS), DESIGN RESOURCES (INCLUDING REFERENCE DESIGNS), APPLICATION OR OTHER DESIGN ADVICE, WEB TOOLS, SAFETY INFORMATION, AND OTHER RESOURCES "AS IS" AND WITH ALL FAULTS, AND DISCLAIMS ALL WARRANTIES, EXPRESS AND IMPLIED, INCLUDING WITHOUT LIMITATION ANY IMPLIED WARRANTIES OF MERCHANTABILITY, FITNESS FOR A PARTICULAR PURPOSE OR NON-INFRINGEMENT OF THIRD PARTY INTELLECTUAL PROPERTY RIGHTS.

These resources are intended for skilled developers designing with TI products. You are solely responsible for (1) selecting the appropriate TI products for your application, (2) designing, validating and testing your application, and (3) ensuring your application meets applicable standards, and any other safety, security, regulatory or other requirements.

These resources are subject to change without notice. TI grants you permission to use these resources only for development of an application that uses the TI products described in the resource. Other reproduction and display of these resources is prohibited. No license is granted to any other TI intellectual property right or to any third party intellectual property right. TI disclaims responsibility for, and you fully indemnify TI and its representatives against any claims, damages, costs, losses, and liabilities arising out of your use of these resources.

TI's products are provided subject to [TI's Terms of Sale](#), [TI's General Quality Guidelines](#), or other applicable terms available either on [ti.com](#) or provided in conjunction with such TI products. TI's provision of these resources does not expand or otherwise alter TI's applicable warranties or warranty disclaimers for TI products. Unless TI explicitly designates a product as custom or customer-specified, TI products are standard, catalog, general purpose devices.

TI objects to and rejects any additional or different terms you may propose.

Copyright © 2026, Texas Instruments Incorporated

Last updated 10/2025