

SN54F245, SN74F245 OCTAL BUS TRANSCEIVERS WITH 3-STATE OUTPUTS

SDFS010A – MARCH 1987 – REVISED OCTOBER 1993

- 3-State Outputs Drive Bus Lines Directly
- Package Options Include Plastic Small-Outline (SOIC) and Shrink Small-Outline (SSOP) Packages, Ceramic Chip Carriers, and Plastic and Ceramic DIPs

description

These octal bus transceivers are designed for asynchronous communication between data buses. The devices transmit data from the A bus to the B bus or from the B bus to the A bus depending upon the logic level at the direction-control (DIR) input. The output enable (\overline{OE}) input can be used to disable the device so the buses are effectively isolated.

The SN74F245 is available in TI's shrink small-outline package (DB), which provides the same I/O pin count and functionality of standard small-outline packages in less than half the printed-circuit-board area.

The SN54F245 is characterized for operation over the full military temperature range of -55°C to 125°C . The SN74F245 is characterized for operation from 0°C to 70°C .

SN54F245 . . . J PACKAGE
SN74F245 . . . DB, DW, OR N PACKAGE
(TOP VIEW)

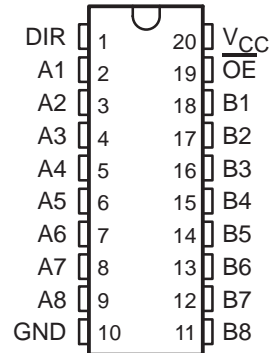

SN54F245 . . . FK PACKAGE
(TOP VIEW)

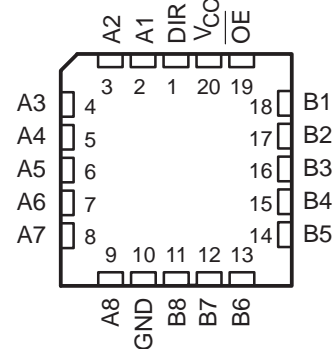

FUNCTION TABLE

INPUTS		OPERATION
\overline{OE}	DIR	
L	L	B data to A bus
L	H	A data to B bus
H	X	Isolation

SN54F245, SN74F245 OCTAL BUS TRANSCEIVERS WITH 3-STATE OUTPUTS

SDFS010A – MARCH 1987 – REVISED OCTOBER 1993

logic symbol†

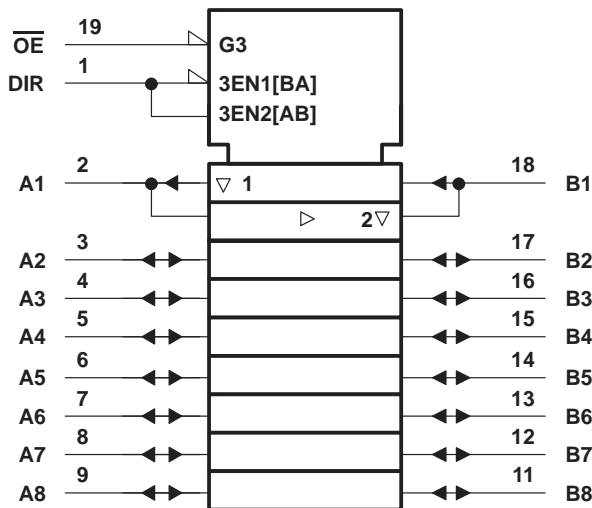

logic diagram (positive logic)

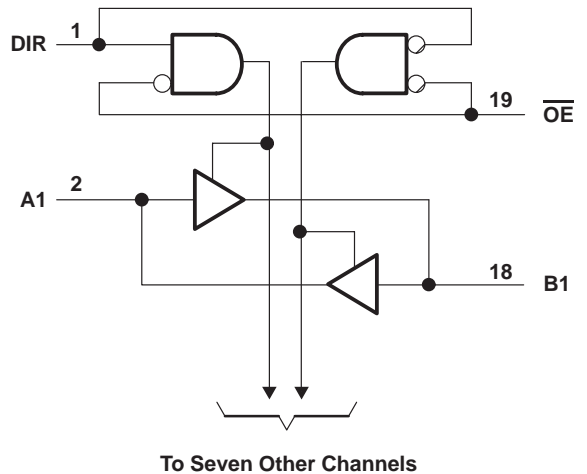

† This symbol is in accordance with ANSI/IEEE Std 91-1984 and IEC Publication 617-12.

absolute maximum ratings over operating free-air temperature range (unless otherwise noted)‡

Supply voltage range, V_{CC}	-0.5 V to 7 V
Input voltage range, V_I (except I/O ports) (see Note 1)	-1.2 V to 7 V
Input current range	-30 mA to 5 mA
Voltage range applied to any output in the disabled or power-off state	-0.5 V to 5.5 V
Voltage range applied to any output in the high state	-0.5 V to V_{CC}
Current into any output in the low state: SN54F245 (A1 thru A8)	40 mA
SN54F245 (B1 thru B8)	96 mA
SN74F245 (A1 thru A8)	48 mA
SN74F245 (B1 thru B8)	128 mA
Operating free-air temperature range: SN54F245	-55°C to 125°C
SN74F245	0°C to 70°C
Storage temperature range	-65°C to 150°C

‡ Stresses beyond those listed under "absolute maximum ratings" may cause permanent damage to the device. These are stress ratings only and functional operation of the device at these or any other conditions beyond those indicated under "recommended operating conditions" is not implied. Exposure to absolute-maximum-rated conditions for extended periods may affect device reliability.

NOTE 1: The input voltage ratings may be exceeded provided the input current ratings are observed.

SN54F245, SN74F245 OCTAL BUS TRANSCEIVERS WITH 3-STATE OUTPUTS

SDFS010A – MARCH 1987 – REVISED OCTOBER 1993

recommended operating conditions

		SN54F245			SN74F245			UNIT
		MIN	NOM	MAX	MIN	NOM	MAX	
V_{CC}	Supply voltage	4.5	5	5.5	4.5	5	5.5	V
V_{IH}	High-level input voltage	2			2			V
V_{IL}	Low-level input voltage			0.8			0.8	V
I_{IK}	Input clamp current			-18			-18	mA
I_{OH}	High-level output current	A1 thru A8		-3	-3		mA	
		B1 thru B8		-12	-15			
I_{OL}	Low-level output current	A1 thru A8		20	24		mA	
		B1 thru B8		48	64			
T_A	Operating free-air temperature	-55		125	0		70	°C

electrical characteristics over recommended operating free-air temperature range (unless otherwise noted)

PARAMETER		TEST CONDITIONS		SN54F245		SN74F245		UNIT
				MIN	TYP†	MAX	MIN	
V_{IK}		$V_{CC} = 4.5\text{ V}$, $I_I = -18\text{ mA}$			-1.2		-1.2	V
V_{OH}	A1 thru A8	$V_{CC} = 4.5\text{ V}$	$I_{OH} = -1\text{ mA}$	2.5	3.4	2.5	3.4	V
			$I_{OH} = -3\text{ mA}$	2.4	3.3	2.4	3.3	
	B1 thru B8	$V_{CC} = 4.5\text{ V}$	$I_{OH} = -12\text{ mA}$	2	3.2			
			$I_{OH} = -15\text{ mA}$			2	3.1	
Any output		$V_{CC} = 4.75\text{ V}$,	$I_{OH} = -1\text{ mA to } -3\text{ mA}$			2.7		
V_{OL}	A1 thru A8	$V_{CC} = 4.5\text{ V}$	$I_{OL} = 20\text{ mA}$		0.3	0.5		V
			$I_{OL} = 24\text{ mA}$				0.35	
	B1 thru B8	$V_{CC} = 4.5\text{ V}$	$I_{OL} = 48\text{ mA}$		0.38	0.55		
			$I_{OL} = 64\text{ mA}$				0.42	
I_I	A and B	$V_{CC} = 5.5\text{ V}$	$V_I = 5.5\text{ V}$			1	1	mA
	DIR, \overline{OE}		$V_I = 7\text{ V}$			0.1	0.1	
I_{IH}^\ddagger	A and B	$V_{CC} = 5.5\text{ V}$,	$V_I = 2.7\text{ V}$			70	70	μA
	DIR, \overline{OE}					20	20	
I_{IL}^\ddagger	A and B	$V_{CC} = 5.5\text{ V}$,	$V_I = 0.5\text{ V}$			-0.65	-0.65	mA
	DIR, \overline{OE}					-1.2	-1.2	
I_{OS}^\S	A1 thru A8	$V_{CC} = 5.5\text{ V}$,	$V_O = 0$	-60	-150	-60	-150	mA
	B1 thru B8			-100	-225	-100	-225	
I_{CC}	$V_{CC} = 5.5\text{ V}$		Outputs high	70	90	70	90	mA
			Outputs low	95	120	95	120	
			Outputs disabled	85	110	85	110	

† All typical values are at $V_{CC} = 5\text{ V}$, $T_A = 25^\circ\text{C}$.

‡ For I/O ports, the parameters I_{IH} and I_{IL} include the off-state output current.

§ Not more than one output should be shorted at a time, and the duration of the short circuit should not exceed one second.



SN54F245, SN74F245
OCTAL BUS TRANSCEIVERS
WITH 3-STATE OUTPUTS

SDFS010A – MARCH 1987 – REVISED OCTOBER 1993

switching characteristics (see Note 2)

PARAMETER	FROM (INPUT)	TO (OUTPUT)	V _{CC} = 5 V, C _L = 50 pF, R _L = 500 Ω, T _A = 25°C			V _{CC} = 4.5 V to 5.5 V, C _L = 50 pF, R _L = 500 Ω, T _A = MIN to MAX†				UNIT
			'F245			SN54F245		SN74F245		
			MIN	TYP	MAX	MIN	MAX	MIN	MAX	
t _{PLH}	A or B	B or A	1.7	3.8	6	1.2	7.5	1.7	7	ns
t _{PHL}			1.7	4.2	6	1.2	7.5	1.7	7	
t _{PZH}	$\overline{\text{OE}}$	A or B	2.2	4.9	7	1.7	9	2.2	8	ns
t _{PZL}			2.7	5.6	8	2.2	10	2.7	9	
t _{PHZ}	$\overline{\text{OE}}$	A or B	2.2	4.6	6.5	1.7	9	2.2	7.5	ns
t _{PLZ}			1.2	4.6	6.5	1.2	10	1.2	7.5	

† For conditions shown as MIN or MAX, use the appropriate value specified under recommended operating conditions.

NOTE 2: Load circuits and waveforms are shown in Section 1.

PACKAGING INFORMATION

Orderable part number	Status (1)	Material type (2)	Package Pins	Package qty Carrier	RoHS (3)	Lead finish/ Ball material (4)	MSL rating/ Peak reflow (5)	Op temp (°C)	Part marking (6)
85511012A	NRND	Production	LCCC (FK) 20	55 TUBE	No	SNPB	N/A for Pkg Type	-55 to 125	85511012A SNJ54F 245FK
8551101RA	Active	Production	CDIP (J) 20	20 TUBE	No	SNPB	N/A for Pkg Type	-55 to 125	8551101RA SNJ54F245J
8551101SA	Active	Production	CFP (W) 20	25 TUBE	No	SNPB	N/A for Pkg Type	-55 to 125	8551101SA SNJ54F245W
JM38510/34803B2A	Active	Production	LCCC (FK) 20	55 TUBE	No	SNPB	N/A for Pkg Type	-55 to 125	JM38510/ 34803B2A
JM38510/34803B2A.A	Active	Production	LCCC (FK) 20	55 TUBE	No	SNPB	N/A for Pkg Type	-55 to 125	JM38510/ 34803B2A
JM38510/34803BRA	Active	Production	CDIP (J) 20	20 TUBE	No	SNPB	N/A for Pkg Type	-55 to 125	JM38510/ 34803BRA
JM38510/34803BRA.A	Active	Production	CDIP (J) 20	20 TUBE	No	SNPB	N/A for Pkg Type	-55 to 125	JM38510/ 34803BRA
JM38510/34803BSA	Active	Production	CFP (W) 20	25 TUBE	No	SNPB	N/A for Pkg Type	-55 to 125	JM38510/ 34803BSA
JM38510/34803BSA.A	Active	Production	CFP (W) 20	25 TUBE	No	SNPB	N/A for Pkg Type	-55 to 125	JM38510/ 34803BSA
M38510/34803B2A	Active	Production	LCCC (FK) 20	55 TUBE	No	SNPB	N/A for Pkg Type	-55 to 125	JM38510/ 34803B2A
M38510/34803BRA	Active	Production	CDIP (J) 20	20 TUBE	No	SNPB	N/A for Pkg Type	-55 to 125	JM38510/ 34803BRA
M38510/34803BSA	Active	Production	CFP (W) 20	25 TUBE	No	SNPB	N/A for Pkg Type	-55 to 125	JM38510/ 34803BSA
SN54F245J	Active	Production	CDIP (J) 20	20 TUBE	No	SNPB	N/A for Pkg Type	-55 to 125	SN54F245J
SN54F245J.A	Active	Production	CDIP (J) 20	20 TUBE	No	SNPB	N/A for Pkg Type	-55 to 125	SN54F245J
SN74F245DBR	Active	Production	SSOP (DB) 20	2000 LARGE T&R	Yes	NIPDAU	Level-1-260C-UNLIM	0 to 70	F245
SN74F245DBR.A	Active	Production	SSOP (DB) 20	2000 LARGE T&R	Yes	NIPDAU	Level-1-260C-UNLIM	0 to 70	F245
SN74F245DW	Obsolete	Production	SOIC (DW) 20	-	-	Call TI	Call TI	0 to 70	F245
SN74F245DWR	Active	Production	SOIC (DW) 20	2000 LARGE T&R	Yes	NIPDAU	Level-1-260C-UNLIM	0 to 70	F245
SN74F245DWR.A	Active	Production	SOIC (DW) 20	2000 LARGE T&R	Yes	NIPDAU	Level-1-260C-UNLIM	0 to 70	F245

Orderable part number	Status (1)	Material type (2)	Package Pins	Package qty Carrier	RoHS (3)	Lead finish/ Ball material (4)	MSL rating/ Peak reflow (5)	Op temp (°C)	Part marking (6)
SN74F245N	Active	Production	PDIP (N) 20	20 TUBE	Yes	NIPDAU	N/A for Pkg Type	0 to 70	SN74F245N
SN74F245N.A	Active	Production	PDIP (N) 20	20 TUBE	Yes	NIPDAU	N/A for Pkg Type	0 to 70	SN74F245N
SN74F245NE4	Active	Production	PDIP (N) 20	20 TUBE	Yes	NIPDAU	N/A for Pkg Type	0 to 70	SN74F245N
SN74F245NSR	Active	Production	SOP (NS) 20	2000 LARGE T&R	Yes	NIPDAU	Level-1-260C-UNLIM	0 to 70	74F245
SN74F245NSR.A	Active	Production	SOP (NS) 20	2000 LARGE T&R	Yes	NIPDAU	Level-1-260C-UNLIM	0 to 70	74F245
SNJ54F245FK	NRND	Production	LCCC (FK) 20	55 TUBE	No	SNPB	N/A for Pkg Type	-55 to 125	85511012A SNJ54F 245FK
SNJ54F245FK.A	NRND	Production	LCCC (FK) 20	55 TUBE	No	SNPB	N/A for Pkg Type	-55 to 125	85511012A SNJ54F 245FK
SNJ54F245J	Active	Production	CDIP (J) 20	20 TUBE	No	SNPB	N/A for Pkg Type	-55 to 125	8551101RA SNJ54F245J
SNJ54F245J.A	Active	Production	CDIP (J) 20	20 TUBE	No	SNPB	N/A for Pkg Type	-55 to 125	8551101RA SNJ54F245J
SNJ54F245W	Active	Production	CFP (W) 20	25 TUBE	No	SNPB	N/A for Pkg Type	-55 to 125	8551101SA SNJ54F245W
SNJ54F245W.A	Active	Production	CFP (W) 20	25 TUBE	No	SNPB	N/A for Pkg Type	-55 to 125	8551101SA SNJ54F245W

(1) **Status:** For more details on status, see our [product life cycle](#).

(2) **Material type:** When designated, preproduction parts are prototypes/experimental devices, and are not yet approved or released for full production. Testing and final process, including without limitation quality assurance, reliability performance testing, and/or process qualification, may not yet be complete, and this item is subject to further changes or possible discontinuation. If available for ordering, purchases will be subject to an additional waiver at checkout, and are intended for early internal evaluation purposes only. These items are sold without warranties of any kind.

(3) **RoHS values:** Yes, No, RoHS Exempt. See the [TI RoHS Statement](#) for additional information and value definition.

(4) **Lead finish/Ball material:** Parts may have multiple material finish options. Finish options are separated by a vertical ruled line. Lead finish/Ball material values may wrap to two lines if the finish value exceeds the maximum column width.

(5) **MSL rating/Peak reflow:** The moisture sensitivity level ratings and peak solder (reflow) temperatures. In the event that a part has multiple moisture sensitivity ratings, only the lowest level per JEDEC standards is shown. Refer to the shipping label for the actual reflow temperature that will be used to mount the part to the printed circuit board.

(6) Part marking: There may be an additional marking, which relates to the logo, the lot trace code information, or the environmental category of the part.

Multiple part markings will be inside parentheses. Only one part marking contained in parentheses and separated by a "-" will appear on a part. If a line is indented then it is a continuation of the previous line and the two combined represent the entire part marking for that device.

Important Information and Disclaimer:The information provided on this page represents TI's knowledge and belief as of the date that it is provided. TI bases its knowledge and belief on information provided by third parties, and makes no representation or warranty as to the accuracy of such information. Efforts are underway to better integrate information from third parties. TI has taken and continues to take reasonable steps to provide representative and accurate information but may not have conducted destructive testing or chemical analysis on incoming materials and chemicals. TI and TI suppliers consider certain information to be proprietary, and thus CAS numbers and other limited information may not be available for release.

In no event shall TI's liability arising out of such information exceed the total purchase price of the TI part(s) at issue in this document sold by TI to Customer on an annual basis.

OTHER QUALIFIED VERSIONS OF SN54F245, SN74F245 :

- Catalog : [SN74F245](#)
- Military : [SN54F245](#)

NOTE: Qualified Version Definitions:

- Catalog - TI's standard catalog product
- Military - QML certified for Military and Defense Applications

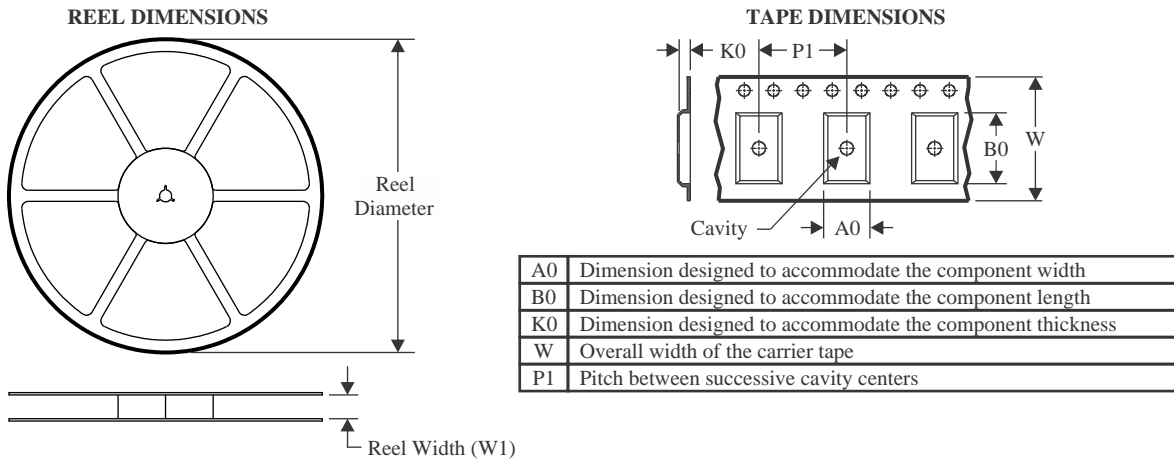
TAPE AND REEL INFORMATION

QUADRANT ASSIGNMENTS FOR PIN 1 ORIENTATION IN TAPE



*All dimensions are nominal

Device	Package Type	Package Drawing	Pins	SPQ	Reel Diameter (mm)	Reel Width W1 (mm)	A0 (mm)	B0 (mm)	K0 (mm)	P1 (mm)	W (mm)	Pin1 Quadrant
SN74F245DBR	SSOP	DB	20	2000	330.0	16.4	8.2	7.5	2.5	12.0	16.0	Q1
SN74F245DWR	SOIC	DW	20	2000	330.0	24.4	10.8	13.3	2.7	12.0	24.0	Q1
SN74F245NSR	SOP	NS	20	2000	330.0	24.4	8.4	13.0	2.5	12.0	24.0	Q1

TAPE AND REEL BOX DIMENSIONS

*All dimensions are nominal

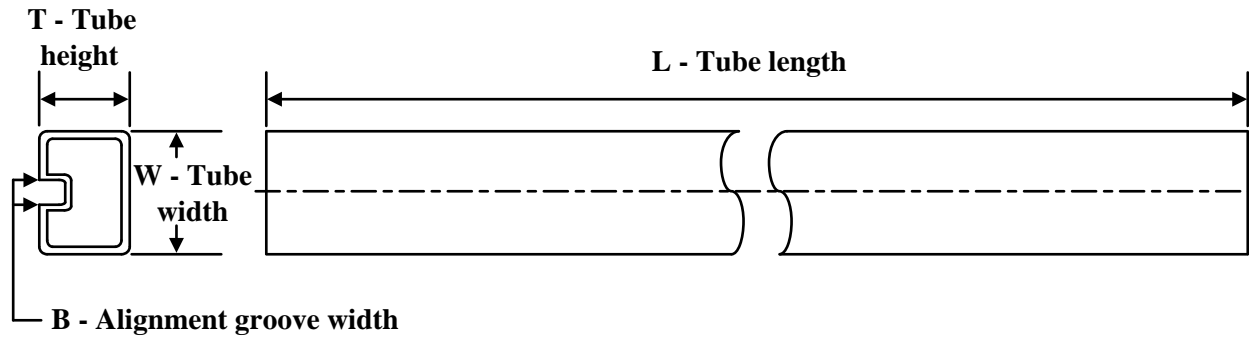
Device	Package Type	Package Drawing	Pins	SPQ	Length (mm)	Width (mm)	Height (mm)
SN74F245DBR	SSOP	DB	20	2000	353.0	353.0	32.0
SN74F245DWR	SOIC	DW	20	2000	356.0	356.0	45.0
SN74F245NSR	SOP	NS	20	2000	356.0	356.0	45.0

TUBE

*All dimensions are nominal

Device	Package Name	Package Type	Pins	SPQ	L (mm)	W (mm)	T (μm)	B (mm)
85511012A	FK	LCCC	20	55	506.98	12.06	2030	NA
8551101SA	W	CFP	20	25	506.98	26.16	6220	NA
JM38510/34803B2A	FK	LCCC	20	55	506.98	12.06	2030	NA
JM38510/34803B2A.A	FK	LCCC	20	55	506.98	12.06	2030	NA
JM38510/34803BSA	W	CFP	20	25	506.98	26.16	6220	NA
JM38510/34803BSA.A	W	CFP	20	25	506.98	26.16	6220	NA
M38510/34803B2A	FK	LCCC	20	55	506.98	12.06	2030	NA
M38510/34803BSA	W	CFP	20	25	506.98	26.16	6220	NA
SN74F245N	N	PDIP	20	20	506	13.97	11230	4.32
SN74F245N.A	N	PDIP	20	20	506	13.97	11230	4.32
SN74F245NE4	N	PDIP	20	20	506	13.97	11230	4.32
SNJ54F245FK	FK	LCCC	20	55	506.98	12.06	2030	NA
SNJ54F245FK.A	FK	LCCC	20	55	506.98	12.06	2030	NA
SNJ54F245W	W	CFP	20	25	506.98	26.16	6220	NA
SNJ54F245W.A	W	CFP	20	25	506.98	26.16	6220	NA

W (R-GDFP-F20)

CERAMIC DUAL FLATPACK



- NOTES:
- A. All linear dimensions are in inches (millimeters).
 - B. This drawing is subject to change without notice.
 - C. This package can be hermetically sealed with a ceramic lid using glass frit.
 - D. Index point is provided on cap for terminal identification only.
 - E. Falls within Mil-Std 1835 GDFP2-F20

J (R-GDIP-T**)

14 LEADS SHOWN

CERAMIC DUAL IN-LINE PACKAGE



DIM \ PINS **	14	16	18	20
A	0.300 (7,62) BSC	0.300 (7,62) BSC	0.300 (7,62) BSC	0.300 (7,62) BSC
B MAX	0.785 (19,94)	.840 (21,34)	0.960 (24,38)	1.060 (26,92)
B MIN	—	—	—	—
C MAX	0.300 (7,62)	0.300 (7,62)	0.310 (7,87)	0.300 (7,62)
C MIN	0.245 (6,22)	0.245 (6,22)	0.220 (5,59)	0.245 (6,22)



4040083/F 03/03

- NOTES:
- All linear dimensions are in inches (millimeters).
 - This drawing is subject to change without notice.
 - This package is hermetically sealed with a ceramic lid using glass frit.
 - Index point is provided on cap for terminal identification only on press ceramic glass frit seal only.
 - Falls within MIL STD 1835 GDIP1-T14, GDIP1-T16, GDIP1-T18 and GDIP1-T20.

GENERIC PACKAGE VIEW

FK 20

LCCC - 2.03 mm max height

8.89 x 8.89, 1.27 mm pitch

LEADLESS CERAMIC CHIP CARRIER

This image is a representation of the package family, actual package may vary.
Refer to the product data sheet for package details.



4229370VA\

N (R-PDIP-T**)

PLASTIC DUAL-IN-LINE PACKAGE

16 PINS SHOWN



- NOTES:
- A. All linear dimensions are in inches (millimeters).
 - B. This drawing is subject to change without notice.
 - Falls within JEDEC MS-001, except 18 and 20 pin minimum body length (Dim A).
 - The 20 pin end lead shoulder width is a vendor option, either half or full width.

DW0020A



PACKAGE OUTLINE

SOIC - 2.65 mm max height

SOIC



4220724/A 05/2016

NOTES:

1. All linear dimensions are in millimeters. Dimensions in parenthesis are for reference only. Dimensioning and tolerancing per ASME Y14.5M.
2. This drawing is subject to change without notice.
3. This dimension does not include mold flash, protrusions, or gate burrs. Mold flash, protrusions, or gate burrs shall not exceed 0.15 mm per side.
4. This dimension does not include interlead flash. Interlead flash shall not exceed 0.43 mm per side.
5. Reference JEDEC registration MS-013.

EXAMPLE BOARD LAYOUT

DW0020A

SOIC - 2.65 mm max height

SOIC



LAND PATTERN EXAMPLE
SCALE:6X



SOLDER MASK DETAILS

4220724/A 05/2016

NOTES: (continued)

- 6. Publication IPC-7351 may have alternate designs.
- 7. Solder mask tolerances between and around signal pads can vary based on board fabrication site.

EXAMPLE STENCIL DESIGN

DW0020A

SOIC - 2.65 mm max height

SOIC



SOLDER PASTE EXAMPLE
BASED ON 0.125 mm THICK STENCIL
SCALE:6X

4220724/A 05/2016

NOTES: (continued)

8. Laser cutting apertures with trapezoidal walls and rounded corners may offer better paste release. IPC-7525 may have alternate design recommendations.
9. Board assembly site may have different recommendations for stencil design.

DB0020A



PACKAGE OUTLINE

SSOP - 2 mm max height

SMALL OUTLINE PACKAGE



4214851/B 08/2019

NOTES:

1. All linear dimensions are in millimeters. Any dimensions in parenthesis are for reference only. Dimensioning and tolerancing per ASME Y14.5M.
2. This drawing is subject to change without notice.
3. This dimension does not include mold flash, protrusions, or gate burrs. Mold flash, protrusions, or gate burrs shall not exceed 0.15 mm per side.
4. This dimension does not include interlead flash. Interlead flash shall not exceed 0.25 mm per side.
5. Reference JEDEC registration MO-150.

EXAMPLE BOARD LAYOUT

DB0020A

SSOP - 2 mm max height

SMALL OUTLINE PACKAGE



LAND PATTERN EXAMPLE
EXPOSED METAL SHOWN
SCALE: 10X

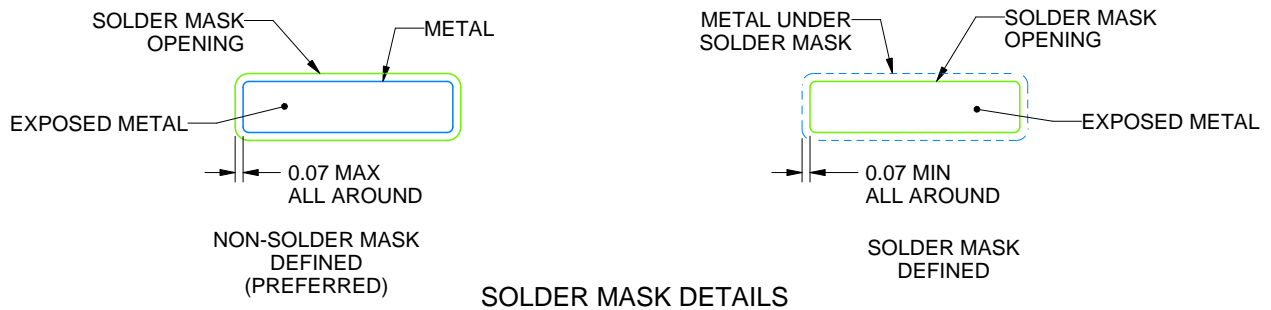

4214851/B 08/2019

NOTES: (continued)

- 6. Publication IPC-7351 may have alternate designs.
- 7. Solder mask tolerances between and around signal pads can vary based on board fabrication site.

EXAMPLE STENCIL DESIGN

DB0020A

SSOP - 2 mm max height

SMALL OUTLINE PACKAGE



SOLDER PASTE EXAMPLE
BASED ON 0.125 mm THICK STENCIL
SCALE: 10X

4214851/B 08/2019

NOTES: (continued)

8. Laser cutting apertures with trapezoidal walls and rounded corners may offer better paste release. IPC-7525 may have alternate design recommendations.
9. Board assembly site may have different recommendations for stencil design.

MECHANICAL DATA

NS (R-PDSO-G**)

PLASTIC SMALL-OUTLINE PACKAGE

14-PINS SHOWN



- NOTES:
- A. All linear dimensions are in millimeters.
 - B. This drawing is subject to change without notice.
 - C. Body dimensions do not include mold flash or protrusion, not to exceed 0,15.

IMPORTANT NOTICE AND DISCLAIMER

TI PROVIDES TECHNICAL AND RELIABILITY DATA (INCLUDING DATASHEETS), DESIGN RESOURCES (INCLUDING REFERENCE DESIGNS), APPLICATION OR OTHER DESIGN ADVICE, WEB TOOLS, SAFETY INFORMATION, AND OTHER RESOURCES "AS IS" AND WITH ALL FAULTS, AND DISCLAIMS ALL WARRANTIES, EXPRESS AND IMPLIED, INCLUDING WITHOUT LIMITATION ANY IMPLIED WARRANTIES OF MERCHANTABILITY, FITNESS FOR A PARTICULAR PURPOSE OR NON-INFRINGEMENT OF THIRD PARTY INTELLECTUAL PROPERTY RIGHTS.

These resources are intended for skilled developers designing with TI products. You are solely responsible for (1) selecting the appropriate TI products for your application, (2) designing, validating and testing your application, and (3) ensuring your application meets applicable standards, and any other safety, security, regulatory or other requirements.

These resources are subject to change without notice. TI grants you permission to use these resources only for development of an application that uses the TI products described in the resource. Other reproduction and display of these resources is prohibited. No license is granted to any other TI intellectual property right or to any third party intellectual property right. TI disclaims responsibility for, and you fully indemnify TI and its representatives against any claims, damages, costs, losses, and liabilities arising out of your use of these resources.

TI's products are provided subject to [TI's Terms of Sale](#), [TI's General Quality Guidelines](#), or other applicable terms available either on ti.com or provided in conjunction with such TI products. TI's provision of these resources does not expand or otherwise alter TI's applicable warranties or warranty disclaimers for TI products. Unless TI explicitly designates a product as custom or customer-specified, TI products are standard, catalog, general purpose devices.

TI objects to and rejects any additional or different terms you may propose.

Copyright © 2026, Texas Instruments Incorporated

Last updated 10/2025