

SRC419x 192-kHz Stereo Asynchronous Sample-Rate Converters

1 Features

- Automatic Sensing of the Input-to-Output Sampling Ratio
- Wide Input-to-Output Sampling Range: 16:1 to 1:16
- Supports Input and Output Sampling Rates Up to 212 kHz
- Dynamic Range: 144 dB (–60-dBFS Input, BW = 20 Hz to $f_s/2$, A-Weighted)
- THD+N: –140 dB (0-dBFS Input, BW = 20 Hz to $f_s/2$)
- Attenuates Sampling and Reference Clock Jitter
- High-Performance, Linear-Phase Digital Filtering with Stop Band Attenuation Greater than 140 dB
- Flexible Audio Serial Ports:
 - Master or Slave-Mode Operation
 - Supports I²S, Left-Justified, Right-Justified, and TDM Data Formats
 - Supports 16, 18, 20, or 24-Bit Audio Data
 - TDM Mode Allows Daisy-Chaining of up to Eight Devices
- Supports 24-, 20-, 18-, or 16-Bit Input and Output Data: All Output Data is Dithered from the Internal 28-Bit Data Path
- Low Group Delay Option for Interpolation Filter
- Direct Downsampling Option for Decimation Filter (SRC4193 Only)
- SPI Port Provides Access to Internal Control Registers (SRC4193 Only)
- Soft Mute Function
- Bypass Mode
- Programmable Digital Output Attenuation (SRC4193 Only); 256 Steps: 0 dB to –127.5 dB, 0.5-dB/step
- Power Down Mode
- Operates From a Single 3.3-V Power Supply
- Small 28-Pin SSOP Package
- Pin Compatible with the AD1896 (SRC4192 Only)

2 Applications

- Digital Mixing Consoles
- Digital Audio Workstations
- Audio Distribution Systems
- Broadcast Studio Equipment
- High-End A/V Receivers
- General Digital Audio Processing

3 Description

The SRC4192 and SRC4193 devices are asynchronous, sample-rate converters designed for professional and broadcast audio applications. The SRC4192 and SRC4193 devices combine a wide input-to-output sampling ratio with outstanding dynamic range and ultra-low distortion. Input and output serial ports support standard audio formats, as well as a Time Division Multiplexed (TDM) mode. Flexible audio interfaces allow the SRC4192 and SRC4193 devices to connect to a wide range of audio data converters, digital audio receivers and transmitters, and digital signal processors.

The SRC4192 device is a standalone, pin-programmed device, with control pins for mode, data format, mute, bypass, and low group-delay functions. The SRC4193 device is a software-controlled device featuring a serial peripheral interface (SPI) port, which is utilized to program all functions through the internal control registers.

The SRC4192 and SRC4193 devices can operate from a single 3.3-V power supply. A separate digital I/O supply (V_{IO}) operates over the 1.65-V to 3.6-V supply range, allowing greater flexibility when interfacing to current and future generation signal processors and logic devices. Both devices are available in a 28-pin SSOP package.

Device Information⁽¹⁾

PART NUMBER	PACKAGE	BODY SIZE (NOM)
SRC4192	SSOP (28)	5.30 mm x 10.20 mm
SRC4193		

(1) For all available packages, see the orderable addendum at the end of the data sheet.

Simplified Application Diagram

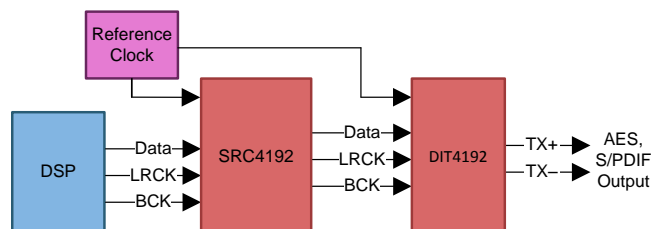

Table of Contents

1 Features 1 2 Applications 1 3 Description 1 4 Revision History 2 5 Pin Configuration and Functions 3 6 Specifications 4 6.1 Absolute Maximum Ratings 4 6.2 ESD Ratings 4 6.3 Recommended Operating Conditions 4 6.4 Thermal Information 5 6.5 Electrical Characteristics 5 6.6 Switching Characteristics 6 6.7 Typical Characteristics 7 7 Detailed Description 18 7.1 Overview 18 7.2 Functional Block Diagram 19 7.3 Feature Description 19	7.4 Device Functional Modes 24 7.5 Register Maps 25 8 Application and Implementation 28 8.1 Application Information 28 8.2 Typical Application 31 9 Power Supply Recommendations 33 10 Layout 33 10.1 Layout Guidelines 33 10.2 Layout Example 35 11 Device and Documentation Support 37 11.1 Documentation Support 37 11.2 Related Links 37 11.3 Community Resources 37 11.4 Trademarks 37 11.5 Electrostatic Discharge Caution 37 11.6 Glossary 37 12 Mechanical, Packaging, and Orderable Information 37
--	--

4 Revision History

NOTE: Page numbers for previous revisions may differ from page numbers in the current version.

Changes from Revision B (September 2007) to Revision C	Page
<ul style="list-style-type: none"> • Added <i>ESD Ratings</i> table, <i>Feature Description</i> section, <i>Device Functional Modes</i>, <i>Application and Implementation</i> section, <i>Power Supply Recommendations</i> section, <i>Layout</i> section, <i>Device and Documentation Support</i> section, and <i>Mechanical, Packaging, and Orderable Information</i> section. 	1

Changes from Revision A (July 2003) to Revision B	Page
<ul style="list-style-type: none"> • Added U.S. patent number to note (1) U.S. Patent No. 7,262,716. 	1

5 Pin Configuration and Functions

SRC4192 DB Package
28-Pin SSOP
Top View

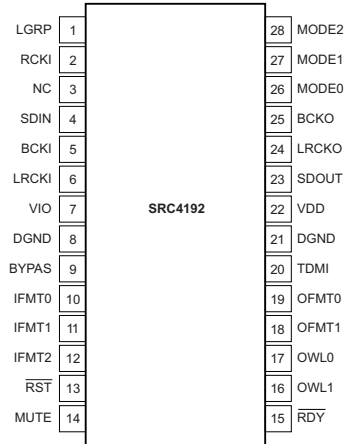

SRC4193 DB Package
28-Pin SSOP
Top View

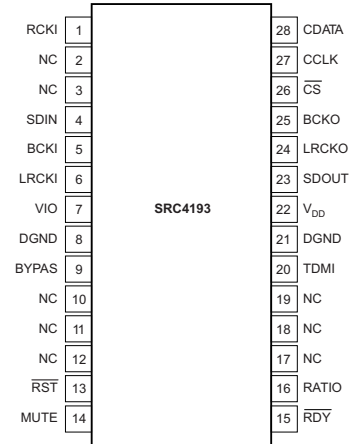

Pin Functions

NAME	PIN		I/O	DESCRIPTION
	SRC4192	SRC4193		
BCKI	5	5	I	Input port bit clock I/O
BCKO	25	25	O	Output port bit clock I/O
BYPAS	9	9	I	ASRC bypass control input (Active High)
CCLK	—	27	I	SPI port data clock input
CDATA	—	28	I	SPI port serial data input
CS	—	26	I	SPI port chip select input (Active Low)
DGND	8, 21	8, 21	—	Digital ground
IFMT0	10	—	I	Input port data format control input
IFMT1	11	—	I	Input port data format control input
IFMT2	12	—	I	Input port data format control input
LGRP	1	—	I	Low group delay control input (active high)
LRCKI	6	6	I	Input port left/right word clock I/O
LRCKO	24	24	O	Output port left/right word clock I/O
MODE0	26	—	I	Serial port mode control input
MODE1	27	—	I	Serial port mode control input
MODE2	28	—	I	Serial port mode control input
MUTE	14	14	I	Output mute control input (active high)
NC	3	2,3,10,11,12, 17,18,19	—	No connection
OFMT0	19	—	I	Output port data format control input
OFMT1	18	—	I	Output port data format control input
OWL0	17	—	I	Output port data word length control input
OWL1	16	—	I	Output port data word length control input
RATIO	—	16	O	Input-to-output ratio flag output Low output denotes output rate lower than input rate. High output denotes output rate higher than input rate.
RCKI	2	1	I	Reference Clock Input
RDY	15	15	O	ASRC Ready Status Output (Active Low)

Pin Functions (continued)

PIN			I/O	DESCRIPTION
NAME	SRC4192	SRC4193		
$\overline{\text{RST}}$	13	13	I	Reset Input (Active Low)
SDIN	4	4	I	Audio Serial Data Input
SDOUT	23	23	O	Audio Serial Data Output
TDMI	20	20	I	TDM Data Input (Connect to DGND when not in use)
V _{DD}	22	22	I	Digital Core Supply, 3.3 V
V _{IO}	7	7	I	Digital I/O Supply, 1.65 V to V _{DD}

6 Specifications

6.1 Absolute Maximum Ratings

over operating free-air temperature range (unless otherwise noted) ⁽¹⁾

		MIN	MAX	UNIT
Supply Voltage	V _{DD}	-0.3	4	V
	V _{IO}	-0.3	4	
Digital Input Voltage		-0.3	4	
Operating Temperature		-45	85	°C
Storage temperature, T _{stg}		-65	150	°C

- (1) Stresses beyond those listed under *Absolute Maximum Ratings* may cause permanent damage to the device. These are stress ratings only, which do not imply functional operation of the device at these or any other conditions beyond those indicated under *Recommended Operating Conditions*. Exposure to absolute-maximum-rated conditions for extended periods may affect device reliability.

6.2 ESD Ratings

		VALUE	UNIT
V _(ESD) Electrostatic discharge	Human-body model (HBM), per ANSI/ESDA/JEDEC JS-001 ⁽¹⁾	±3000	V
	Charged-device model (CDM), per JEDEC specification JESD22-C101 ⁽²⁾	±1500	

- (1) JEDEC document JEP155 states that 500-V HBM allows safe manufacturing with a standard ESD control process.

- (2) JEDEC document JEP157 states that 250-V CDM allows safe manufacturing with a standard ESD control process.

6.3 Recommended Operating Conditions

over operating free-air temperature range (unless otherwise noted)

		MIN	NOM	MAX	UNIT
Supply voltage	V _{DD}	3	3.3	3.6	V
	V _{IO} 1.8 V	1.65	1.8	1.95	
	V _{IO} 3.3 V	3	3.3	3.6	
Operating temperature		-45		85	°C

6.4 Thermal Information

THERMAL METRIC ⁽¹⁾		SRC4192 SRC4193	UNIT
		DB (SSOP)	
		28 PINS	
R _{θJA}	Junction-to-ambient thermal resistance	78.6	°C/W
R _{θJC(top)}	Junction-to-case (top) thermal resistance	38.1	°C/W
R _{θJB}	Junction-to-board thermal resistance	39.3	°C/W
Ψ _{JT}	Junction-to-top characterization parameter	7.1	°C/W
Ψ _{JB}	Junction-to-board characterization parameter	38.9	°C/W
R _{θJC(bot)}	Junction-to-case (bottom) thermal resistance	N/A	°C/W

(1) For more information about traditional and new thermal metrics, see the *Semiconductor and IC Package Thermal Metrics* application report, [SPRA953](#).

6.5 Electrical Characteristics

All parameters specified with T_A = 25°C, V_{DD} = 3.3 V, and V_{IO} = 3.3 V, unless otherwise noted.

PARAMETER	TEST CONDITIONS	MIN	TYP	MAX	UNIT
DYNAMIC PERFORMANCE⁽¹⁾					
Resolution			24		Bits
f _{SIN} Input sampling frequency		4		212	kHz
f _{SOUT} Output sampling frequency		4		212	kHz
Input: output sampling ratio	Upsampling			1:16	
	Downsampling			16:1	
Dynamic range	44.1 kHz; 48 kHz	BW = 20 Hz to f _{SOUT} /2, -60-dBFS Input f _{IN} = 1 kHz, Unweighted (add 3 dB to spec for A-weighted result)		140	dB
	48 kHz; 44.1 kHz			140	
	48 kHz; 96 kHz			140	
	44.1 kHz; 192 kHz			138	
	96 kHz; 48 kHz			141	
	192 kHz; 12 kHz			141	
	192 kHz; 32 kHz			141	
	192 kHz; 48 kHz			141	
	32 kHz; 48 kHz			140	
12 kHz; 192 kHz		138			
Total harmonic distortion + noise	44.1 kHz; 48 kHz	BW = 20 Hz to f _{SOUT} /2, 0-dBFS Input f _{IN} = 1 kHz, Unweighted		-140	dB
	48 kHz; 44.1 kHz			-140	
	48 kHz; 96 kHz			-140	
	44.1 kHz; 192 kHz			-137	
	96 kHz; 48 kHz			-140	
	192 kHz; 12 kHz			-140	
	192 kHz; 32 kHz			-141	
	192 kHz; 48 kHz			-141	
	32 kHz; 48 kHz			-140	
12 kHz; 192 kHz		-137			
Interchannel gain mismatch			0		dB
Interchannel phase deviation			0		°
Digital attenuation	Minimum	SRC4193 Only		0	dB
	Maximum			-127.5	
	Step Size			0.5	
Mute attenuation	24-Bit Word Length, A-weighted			-144	dB
DIGITAL INTERPOLATION FILTER CHARACTERISTICS					
Passband			0.4535 × f _{SIN}		Hz
Passband ripple				±0.007	dB
Transition band		0.4535 × f _{SIN}		0.5465 × f _{SIN}	Hz
Stop band		0.5465 × f _{SIN}			Hz
Stop band attenuation				-144	dB

(1) Dynamic performance measured with an Audio Precision System Two Cascade or Cascade Plus.

Electrical Characteristics (continued)

All parameters specified with $T_A = 25^\circ\text{C}$, $V_{DD} = 3.3\text{ V}$, and $V_{IO} = 3.3\text{ V}$, unless otherwise noted.

PARAMETER	TEST CONDITIONS	MIN	TYP	MAX	UNIT
Normal group delay (LGRP = 0)	Decimation Filter On (DFLT = 0)		102.53125/ f_{SIN}		s
	Decimation Filter Off (DFLT = 1)		102/ f_{SIN}		
Low group delay (LGRP = 1)	Decimation Filter On (DFLT = 0)		70.53125/ f_{SIN}		s
	Decimation Filter Off (DFLT = 1)		70/ f_{SIN}		
DIGITAL DECIMATION FILTER CHARACTERISTICS					
Passband				0.4535 × f_{SOUT}	Hz
Passband ripple				±0.008	dB
Transition band		0.4535 × f_{SOUT}		0.5465 × f_{SOUT}	Hz
Stop band		0.5465 × f_{SOUT}			Hz
Stop band attenuation		-143			dB
Group delay – decimation filter	DFLT = 0 for SRC4193		36.46875/ f_{SOUT}		s
Direct downsampling	SRC4193 only, DFLT = 1		0		s
DIGITAL I/O CHARACTERISTICS					
V_{IH} High-level input voltage		0.7 × V_{IO}		V_{IO}	V
V_{IL} Low-level input voltage		0		0.3 × V_{IO}	V
I_{IH} High-level input current			0.5	10	μA
I_{IL} Low-level input current			0.5	10	μA
V_{OH} High-level output voltage	$I_{\text{O}} = -4\text{ mA}$	0.8 × V_{IO}		V_{IO}	V
V_{OL} Low-level output voltage	$I_{\text{O}} = +4\text{ mA}$	0		0.2 × V_{IO}	V
C_{IN} Input Capacitance			3		pF
POWER SUPPLIES					
Operating voltage, V_{DD}		3	3.3	3.6	V
Operating voltage, V_{IO}		1.65	3.3	3.6	
Supply current, I_{DD} , power down	$V_{\text{DD}} = 3.3\text{ V}$, $V_{\text{IO}} = 3.3\text{ V}$, $\overline{\text{RST}} = 0$, No Clocks			100	μA
	SRC4193 only, $V_{\text{DD}} = 3.3\text{ V}$, $V_{\text{IO}} = 3.3\text{ V}$, PDN Bit = 0, No Clocks		5		mA
Supply current, I_{DD} , dynamic	$V_{\text{DD}} = 3.3\text{ V}$, $V_{\text{IO}} = 3.3\text{ V}$, $f_{\text{SIN}} = f_{\text{SOUT}} = 192\text{ kHz}$		66		mA
Supply current, I_{IO} , power down	$V_{\text{DD}} = 3.3\text{ V}$, $V_{\text{IO}} = 3.3\text{ V}$, $\overline{\text{RST}} = 0$, No Clocks			100	μA
	SRC4193 only, $V_{\text{DD}} = 3.3\text{ V}$, $V_{\text{IO}} = 3.3\text{ V}$, PDN Bit = 0, No Clocks		21		
Supply current, I_{IO} , dynamic	$V_{\text{DD}} = 3.3\text{ V}$, $V_{\text{IO}} = 3.3\text{ V}$, $f_{\text{SIN}} = f_{\text{SOUT}} = 192\text{ kHz}$		2		mA
Total power dissipation, P_{D} , power down	$V_{\text{DD}} = 3.3\text{ V}$, $V_{\text{IO}} = 3.3\text{ V}$, $\overline{\text{RST}} = 0$, No Clocks			660	μW
	SRC4193 only, $V_{\text{DD}} = 3.3\text{ V}$, $V_{\text{IO}} = 3.3\text{ V}$, PDN Bit = 0, No Clocks		16.6		mW
Total power dissipation, P_{D} , dynamic	$V_{\text{DD}} = 3.3\text{ V}$, $V_{\text{IO}} = 3.3\text{ V}$, $f_{\text{SIN}} = f_{\text{SOUT}} = 192\text{ kHz}$		225		mW

6.6 Switching Characteristics

over operating free-air temperature range (unless otherwise noted)

PARAMETER	TEST CONDITIONS	MIN	TYP	MAX	UNIT
REFERENCE CLOCK TIMING					
RCKI frequency	$f_{\text{SMIN}} = \min(f_{\text{SIN}}, f_{\text{SOUT}})$, $f_{\text{SMAX}} = \max(f_{\text{SIN}}, f_{\text{SOUT}})$	128 × f_{SMIN}		50	MHz
t_{RCKIP} RCKI period		20		1/(128 × f_{SMIN})	ns
t_{RCKIH} RCKI pulsewidth high		0.4 × t_{RCKIP}			ns
t_{RCKIL} RCKI pulsewidth low		0.4 × t_{RCKIP}			ns
RESET TIMING					
t_{RSTL} $\overline{\text{RST}}$ pulse width low		500			ns
Delay following $\overline{\text{RST}}$ rising edge	SRC4193 only	500			μs
INPUT SERIAL PORT TIMING					
t_{LRIS} LRCKI to BCKI setup time		10			ns
t_{SIH} BCKI pulsewidth high		10			ns

Switching Characteristics (continued)

over operating free-air temperature range (unless otherwise noted)

PARAMETER	TEST CONDITIONS	MIN	TYP	MAX	UNIT
t_{SIL}	BCKI pulsewidth low	10			ns
t_{LDIS}	SDIN data setup time	10			ns
t_{LDIH}	SDIN data hold time	10			ns
OUTPUT SERIAL PORT TIMING					
t_{DOPD}	SDOUT data delay time			10	ns
t_{DOH}	SDOUT data hold time	2			ns
t_{SOH}	BCKO pulsewidth high	10			ns
t_{SOL}	BCKO pulsewidth low	5			ns
TDM MODE TIMING					
t_{LROS}	LRCKO setup time	10			ns
t_{LROH}	LRCKO hold time	10			ns
t_{TDMS}	TDMI data setup time	10			ns
t_{TDMH}	TDMI data hold time	10			ns
SPI TIMING					
	CCLK frequency			25	MHz
t_{CDS}	CDATA setup time	12			ns
t_{CDH}	CDATA hold time	8			ns
t_{CSCR}	\overline{CS} falling to CCLK rising	15			ns
t_{CFCS}	CCLK falling to \overline{CS} rising	12			ns

6.7 Typical Characteristics

At $T_A = 25^\circ\text{C}$, $V_{DD} = 3.3\text{ V}$, and $V_{IO} = 3.3\text{ V}$, unless otherwise noted.

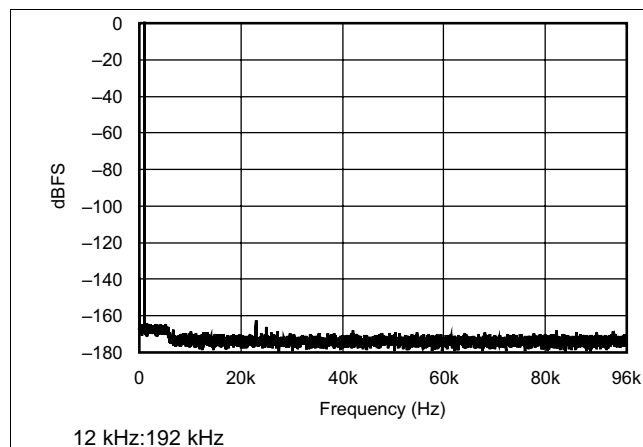

Figure 1. FFT With 1-kHz Input Tone at 0 dBFS

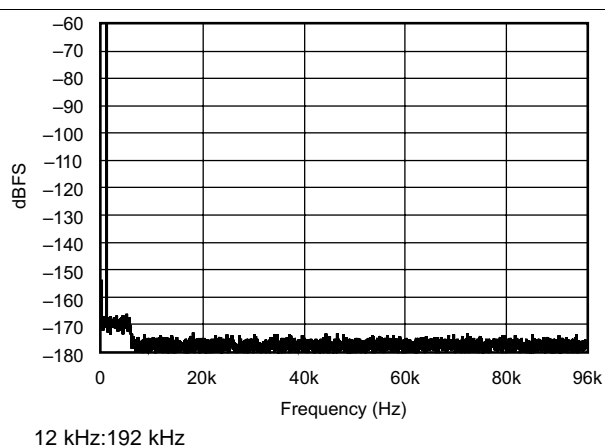
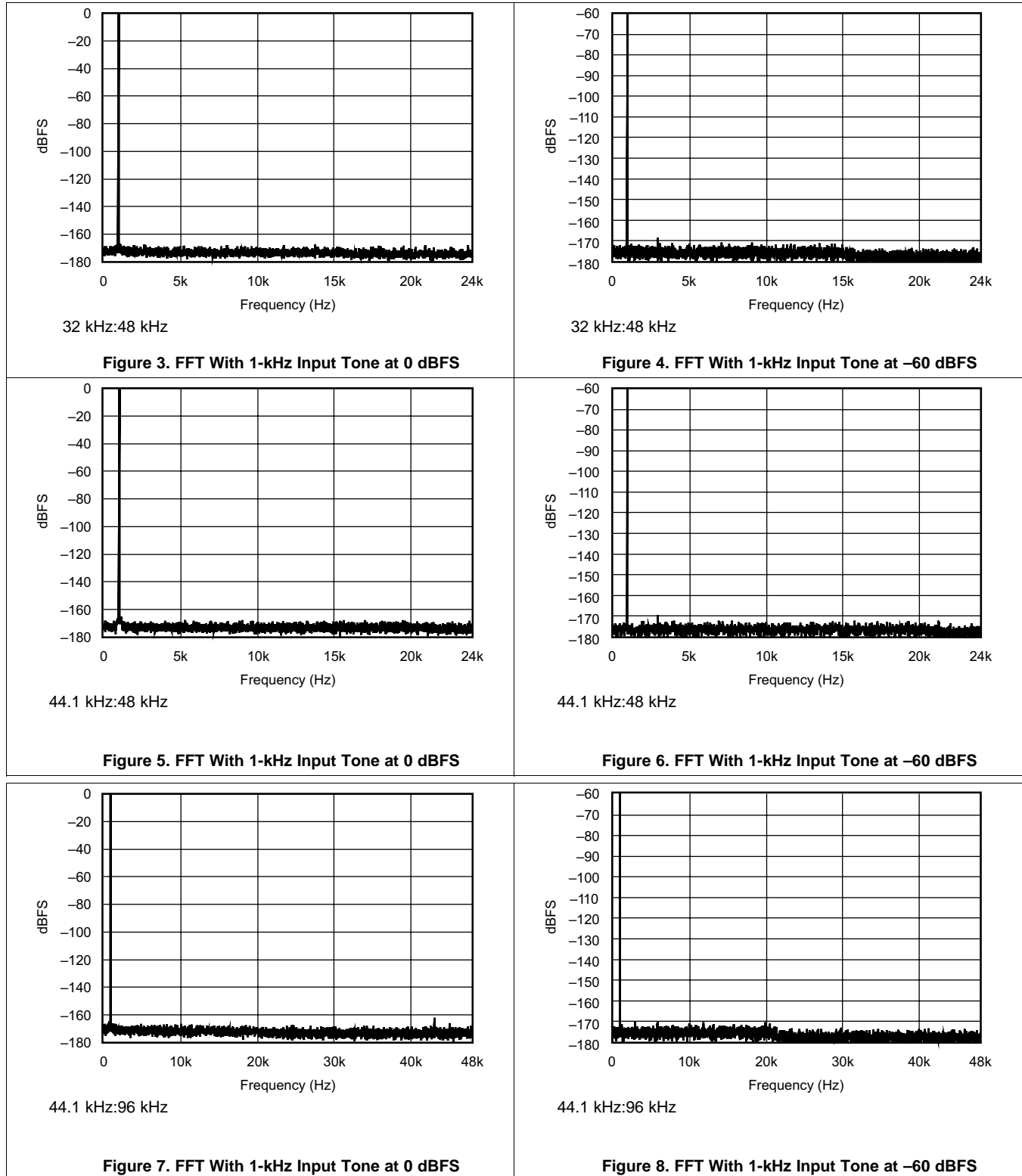

Figure 2. FFT With 1-kHz Input Tone at -60 dBFS

Typical Characteristics (continued)

At $T_A = 25^\circ\text{C}$, $V_{DD} = 3.3\text{ V}$, and $V_{IO} = 3.3\text{ V}$, unless otherwise noted.



Typical Characteristics (continued)

At $T_A = 25^\circ\text{C}$, $V_{DD} = 3.3\text{ V}$, and $V_{IO} = 3.3\text{ V}$, unless otherwise noted.

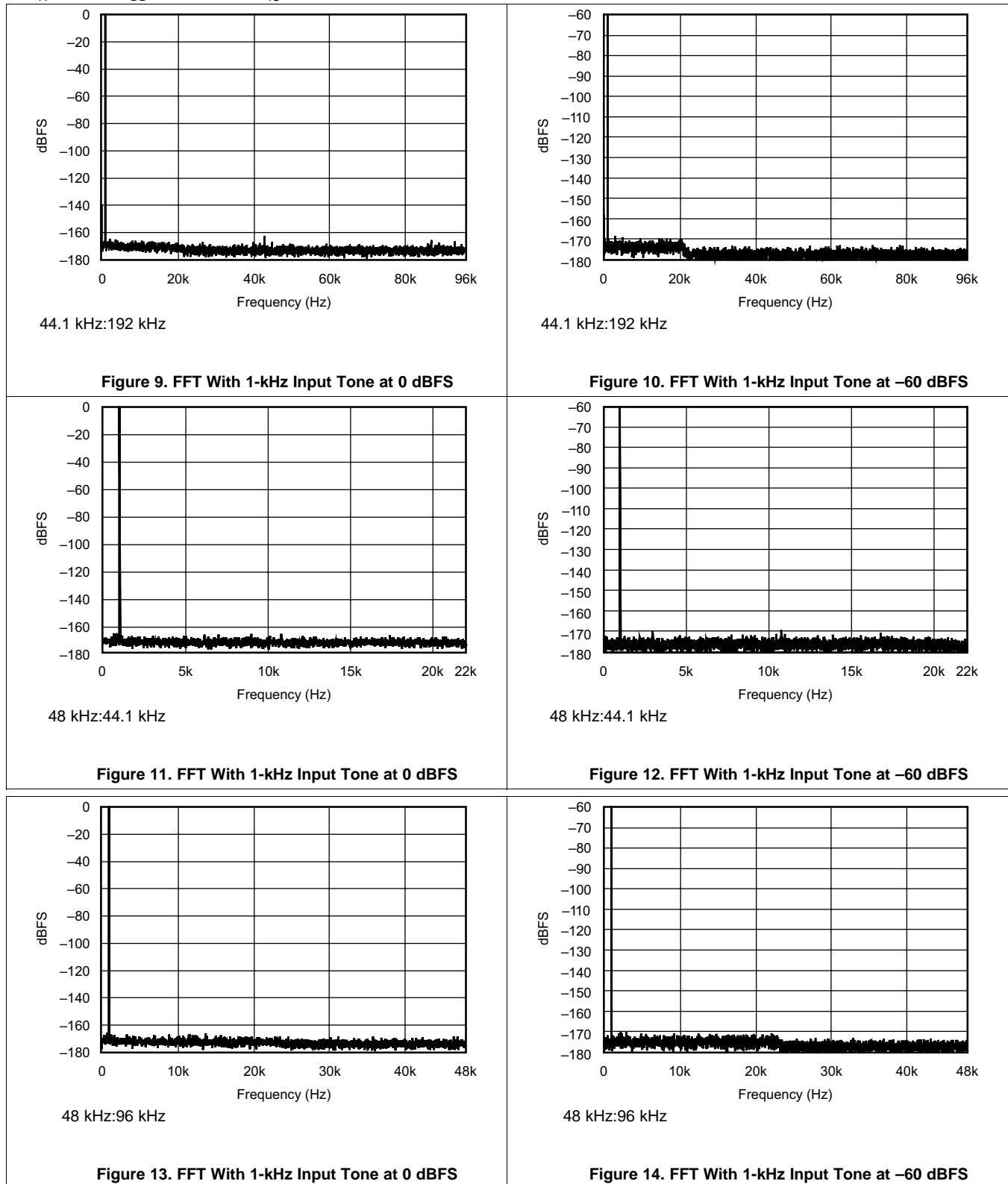

Typical Characteristics (continued)

At $T_A = 25^\circ\text{C}$, $V_{DD} = 3.3\text{ V}$, and $V_{IO} = 3.3\text{ V}$, unless otherwise noted.

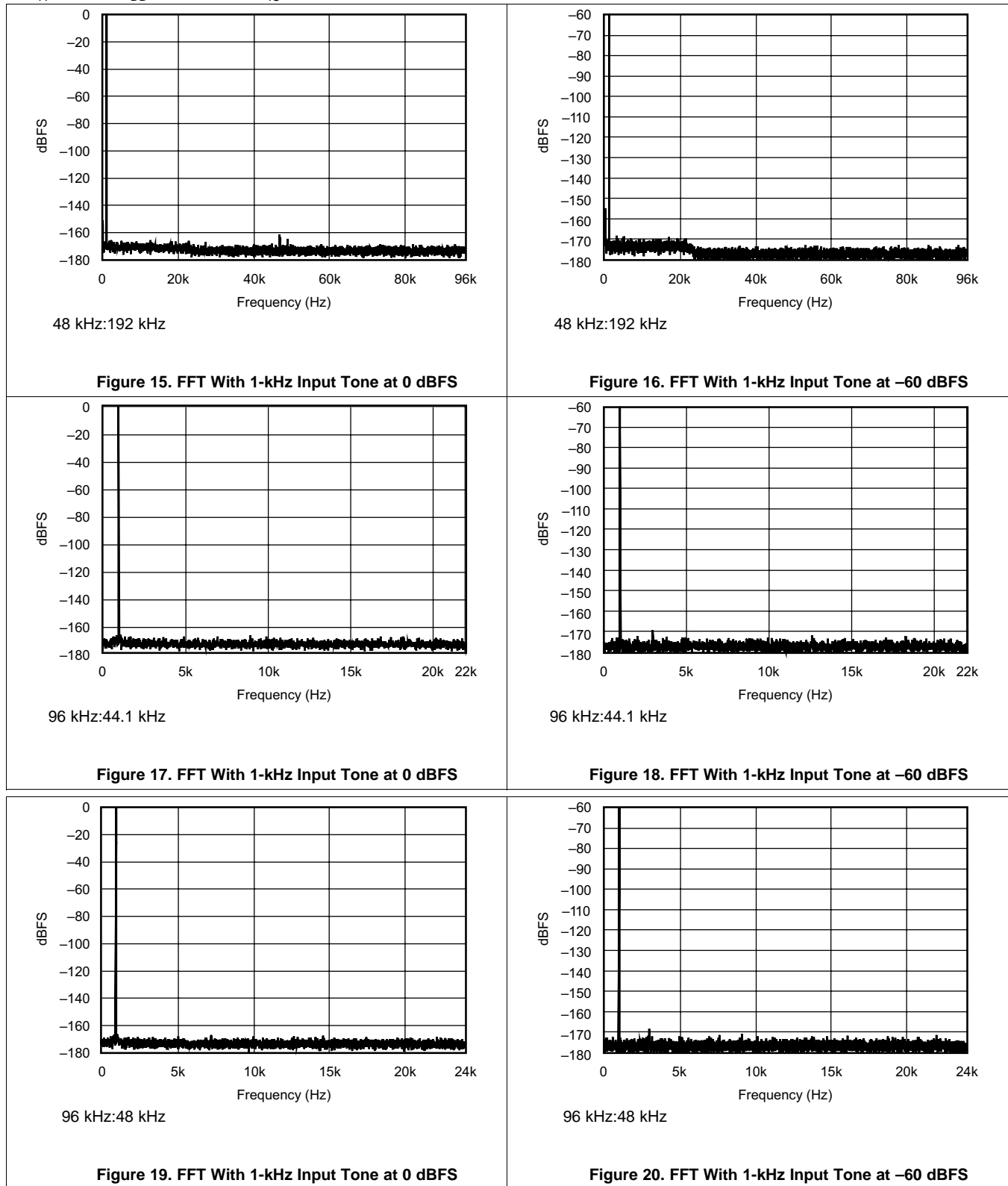

Typical Characteristics (continued)

At $T_A = 25^\circ\text{C}$, $V_{DD} = 3.3\text{ V}$, and $V_{IO} = 3.3\text{ V}$, unless otherwise noted.

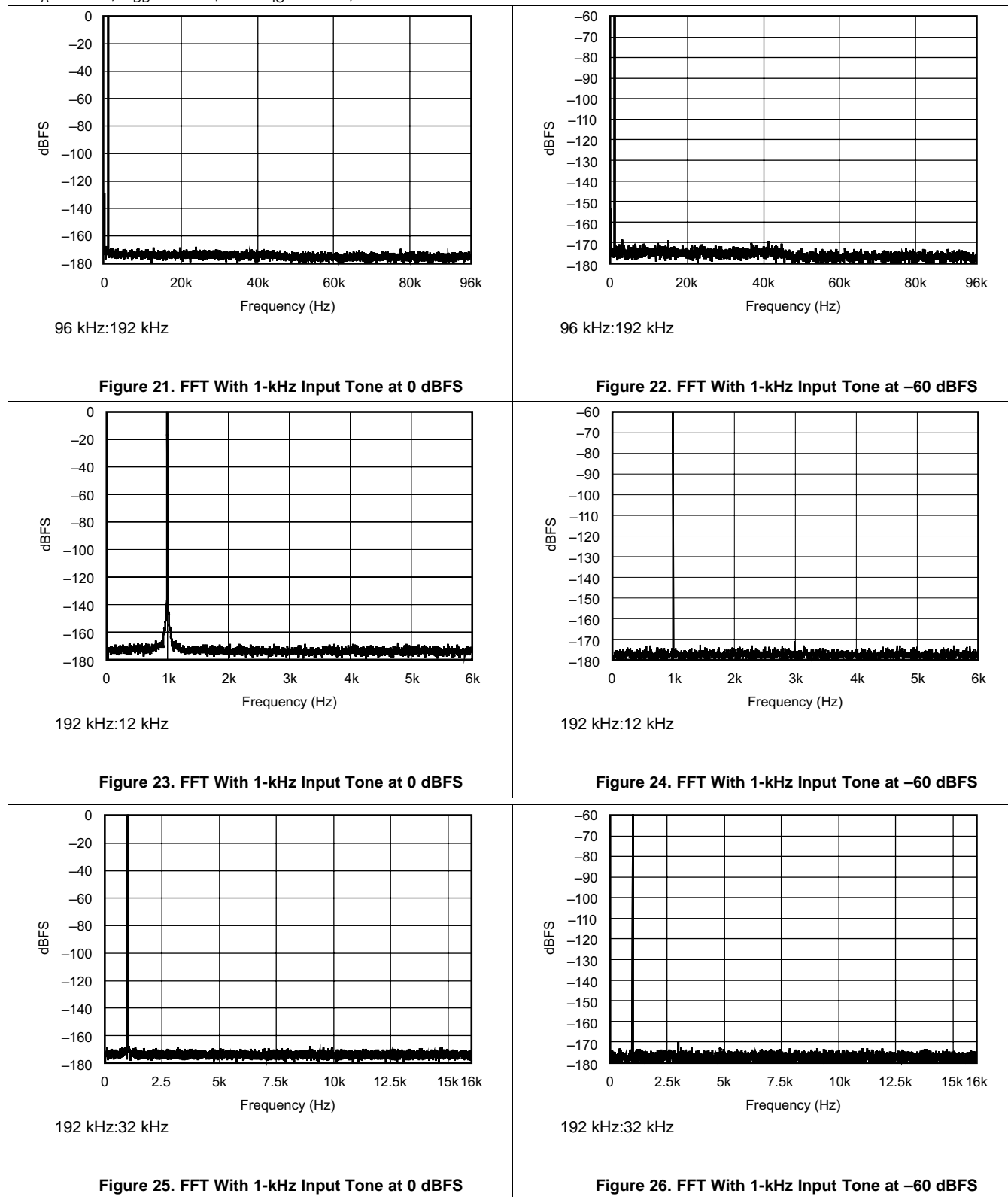

Typical Characteristics (continued)

At $T_A = 25^\circ\text{C}$, $V_{DD} = 3.3\text{ V}$, and $V_{IO} = 3.3\text{ V}$, unless otherwise noted.

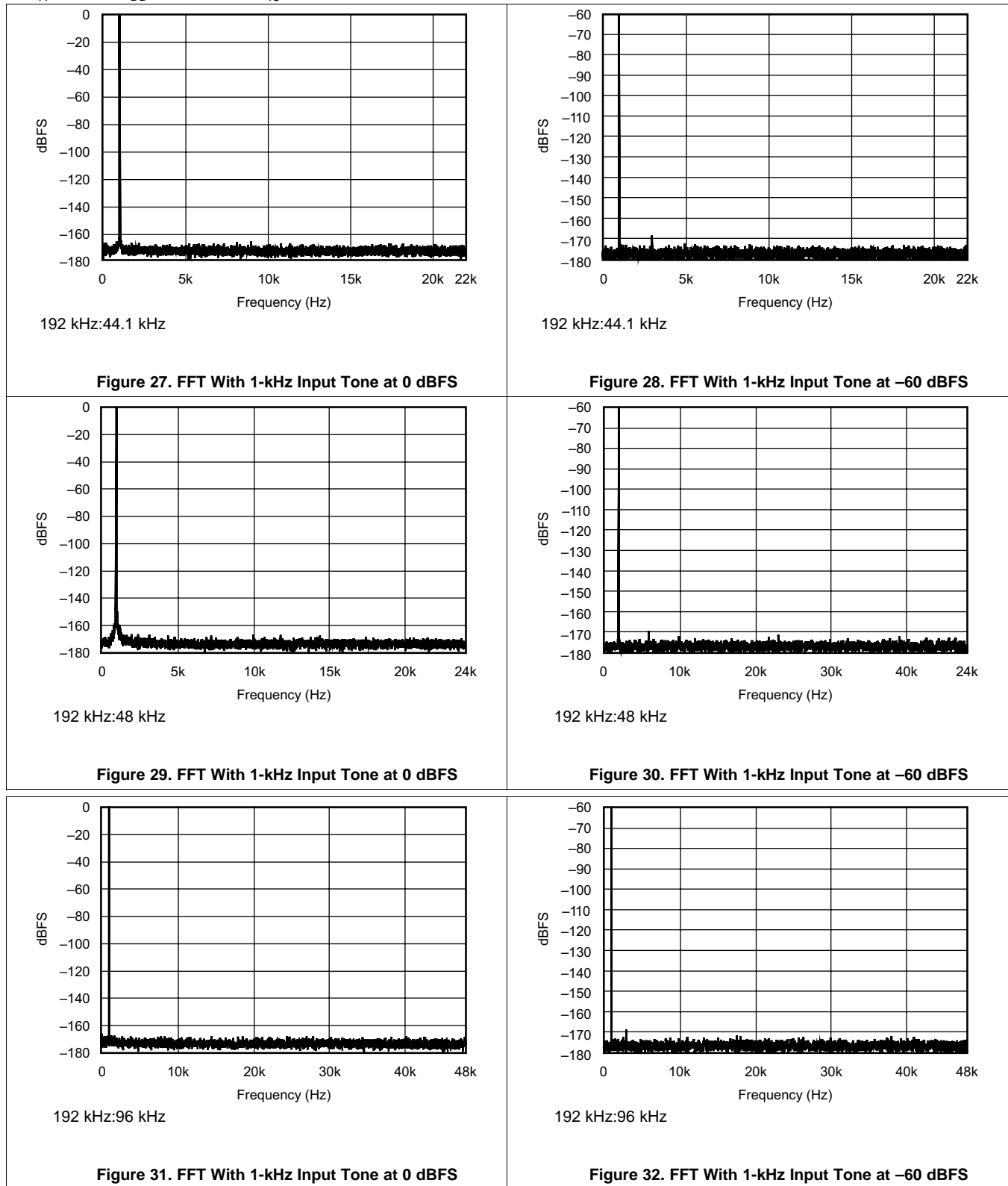

Typical Characteristics (continued)

At $T_A = 25^\circ\text{C}$, $V_{DD} = 3.3\text{ V}$, and $V_{IO} = 3.3\text{ V}$, unless otherwise noted.

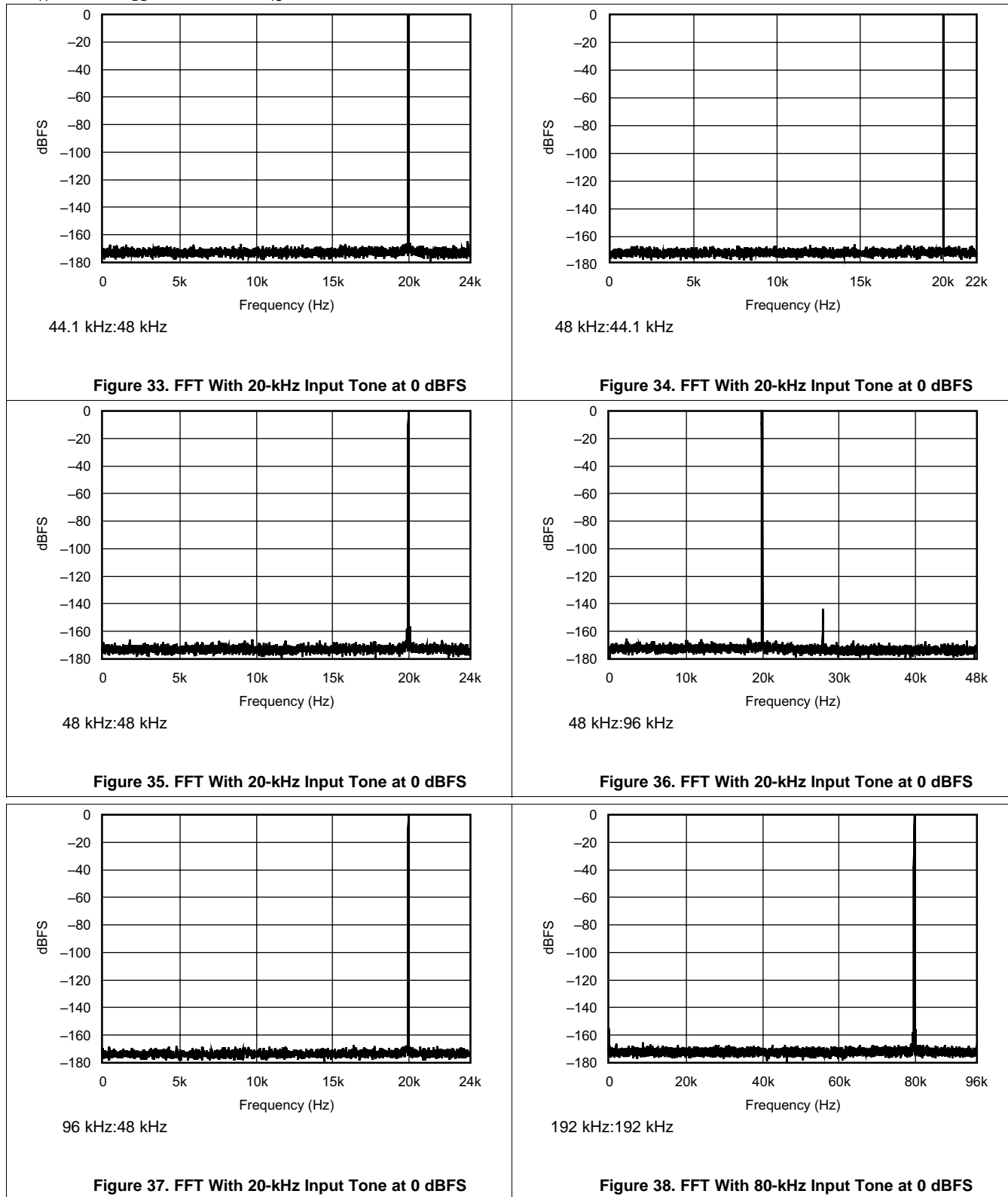

Typical Characteristics (continued)

At $T_A = 25^\circ\text{C}$, $V_{DD} = 3.3\text{ V}$, and $V_{IO} = 3.3\text{ V}$, unless otherwise noted.

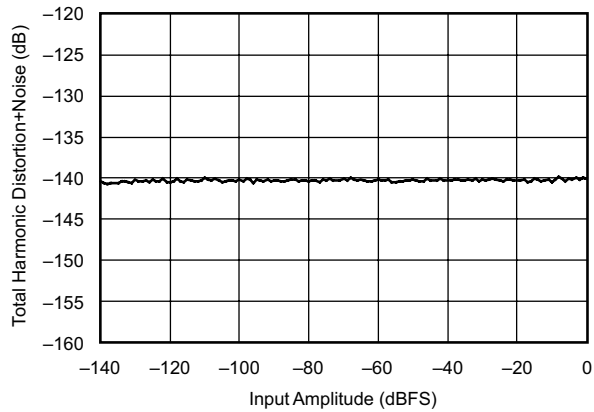

44.1 kHz:48 kHz

Figure 39. THD+N vs Input Amplitude $f_{IN} = 1\text{ kHz}$

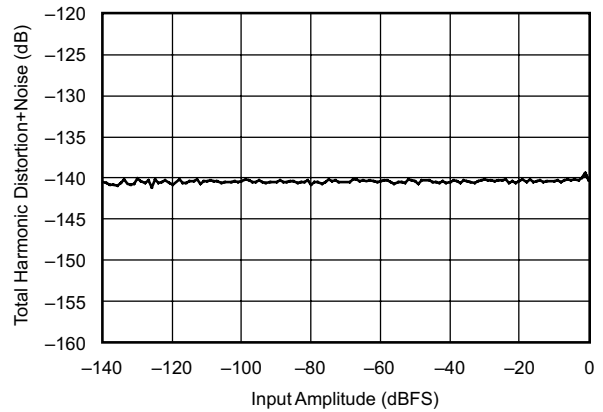

48 kHz:44.1 kHz

Figure 40. THD+N vs Input Amplitude $f_{IN} = 1\text{ kHz}$

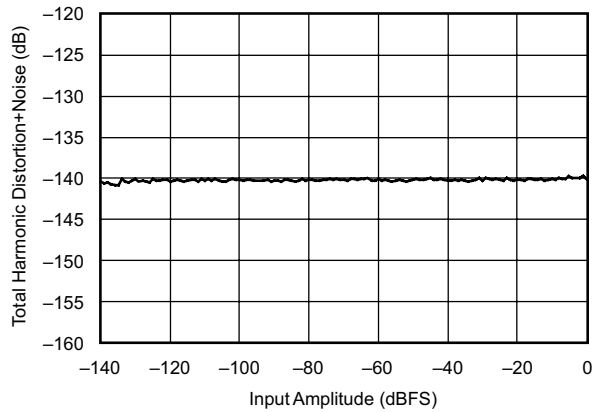

48 kHz:96 kHz

Figure 41. THD+N vs Input Amplitude $f_{IN} = 1\text{ kHz}$

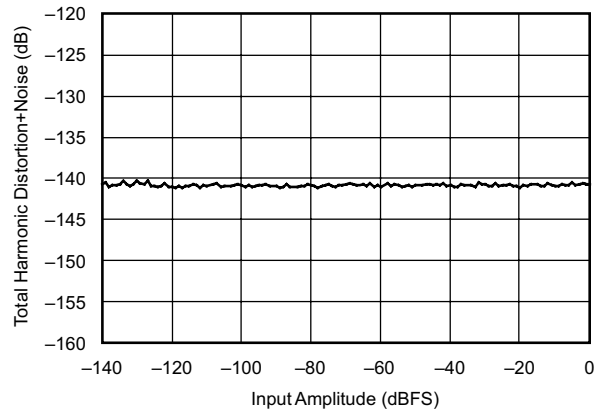

96 kHz:48 kHz

Figure 42. THD+N vs Input Amplitude $f_{IN} = 1\text{ kHz}$

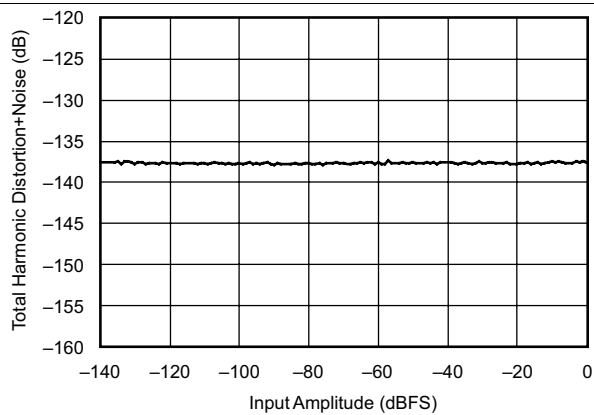

44.1 kHz:192 kHz

Figure 43. THD+N vs Input Amplitude $f_{IN} = 1\text{ kHz}$

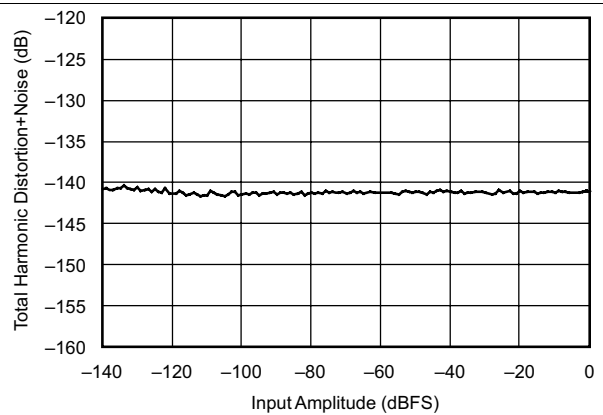

192 kHz:48 kHz

Figure 44. THD+N vs Input Amplitude $f_{IN} = 1\text{ kHz}$

Typical Characteristics (continued)

At $T_A = 25^\circ\text{C}$, $V_{DD} = 3.3\text{ V}$, and $V_{IO} = 3.3\text{ V}$, unless otherwise noted.

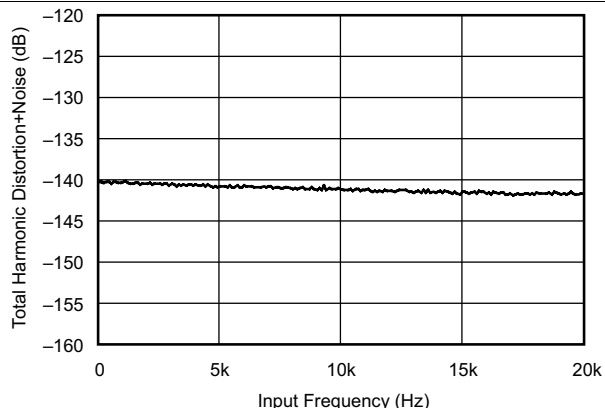

44.1 kHz:48 kHz

Figure 45. THD+N vs Input Frequency, 0-dBFS Input

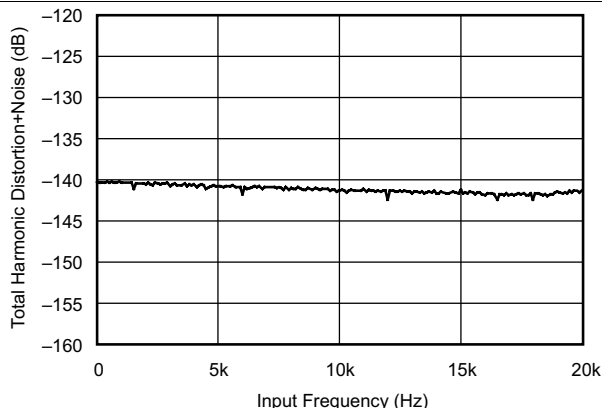

48 kHz:44.1 kHz

Figure 46. THD+N vs Input Frequency, 0-dBFS Input

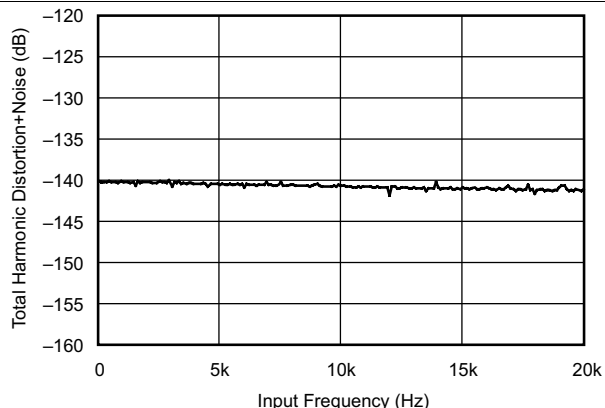

48 kHz:96 kHz

Figure 47. THD+N vs Input Frequency, 0-dBFS Input

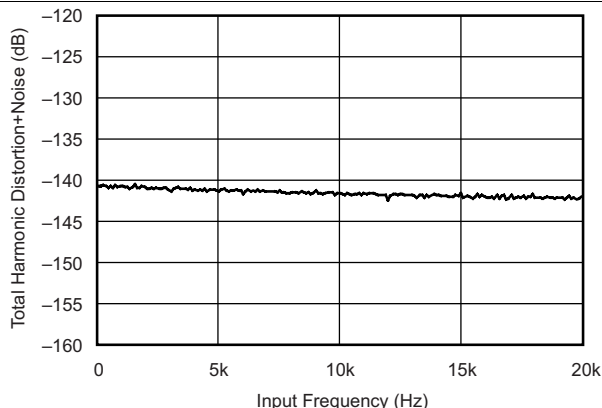

96 kHz:48 kHz

Figure 48. THD+N vs Input Frequency, 0-dBFS Input

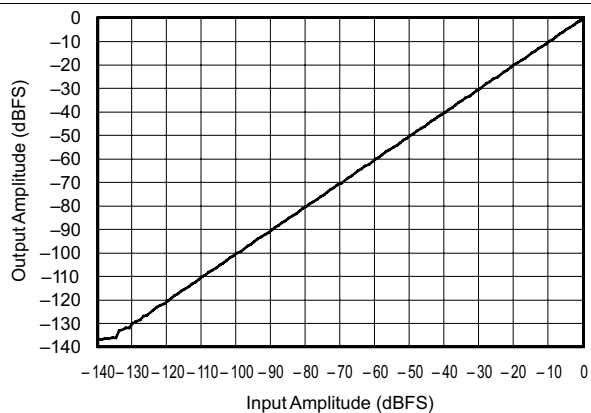

44.1 kHz:48 kHz

Figure 49. Linearity With $f_{IN} = 200\text{ Hz}$

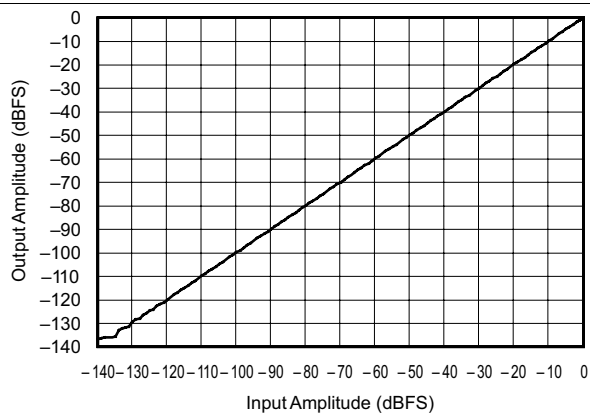

48 kHz:44.1 kHz

Figure 50. Linearity With $f_{IN} = 200\text{ Hz}$

Typical Characteristics (continued)

At $T_A = 25^\circ\text{C}$, $V_{DD} = 3.3\text{ V}$, and $V_{IO} = 3.3\text{ V}$, unless otherwise noted.

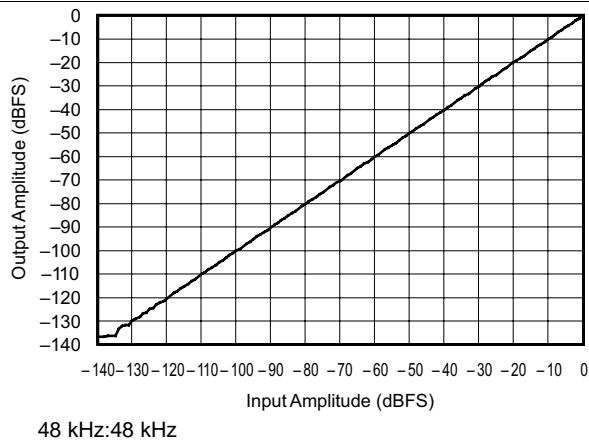

Figure 51. Linearity With $f_{IN} = 200\text{ Hz}$

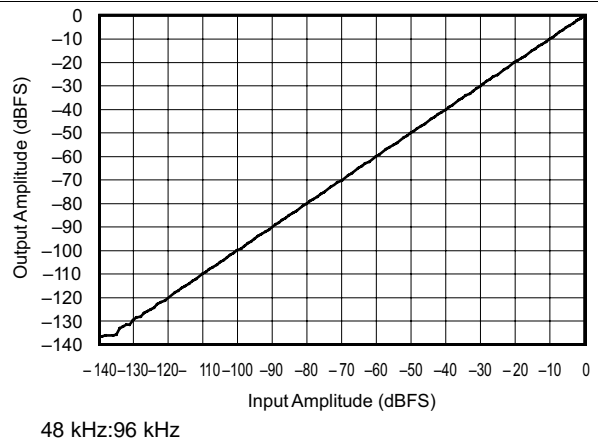

Figure 52. Linearity With $f_{IN} = 200\text{ Hz}$

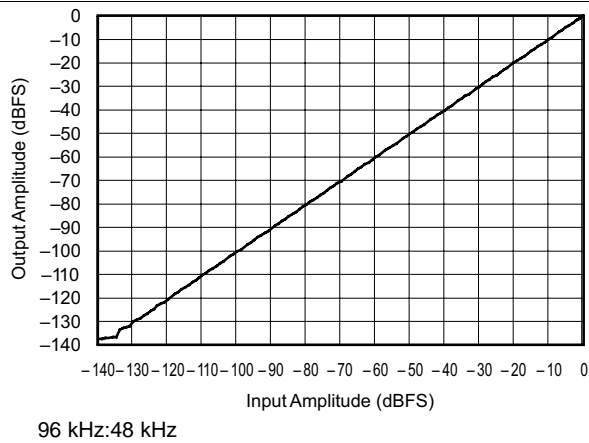

Figure 53. Linearity With $f_{IN} = 200\text{ Hz}$

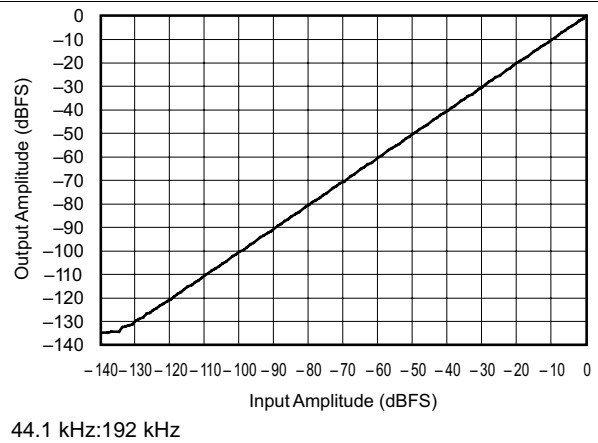

Figure 54. Linearity With $f_{IN} = 200\text{ Hz}$

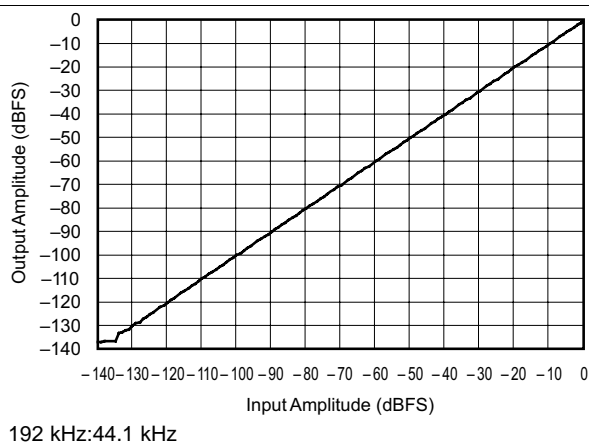

Figure 55. Linearity With $f_{IN} = 200\text{ Hz}$

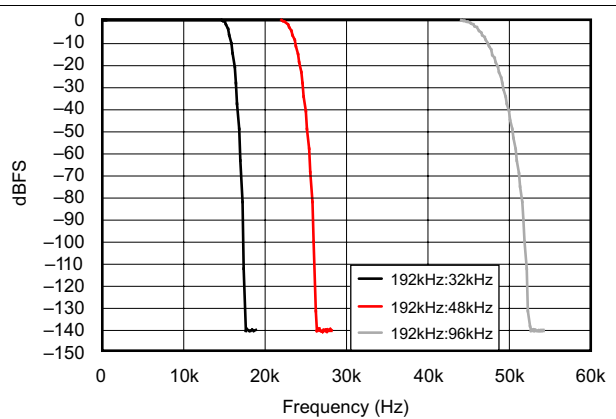
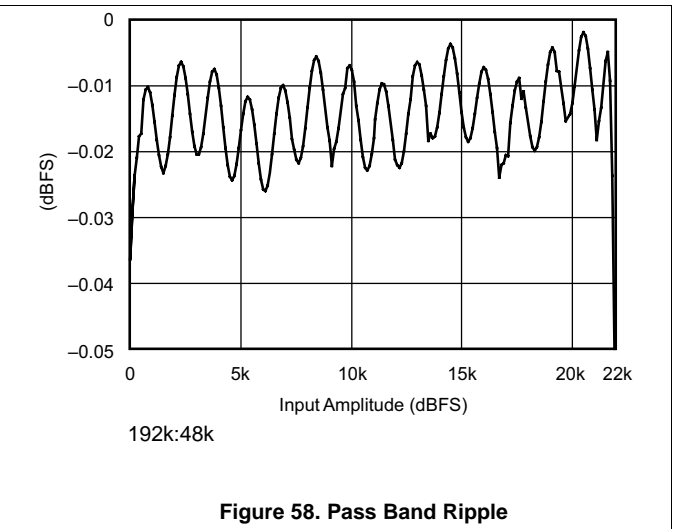
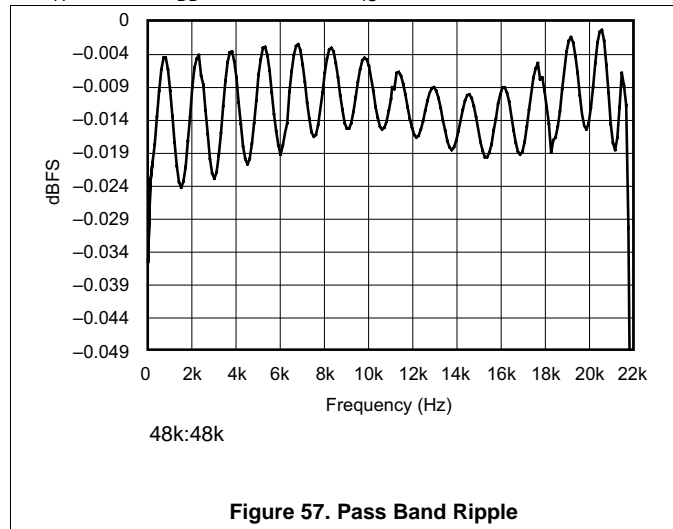

Figure 56. Frequency Response With 0-dBFS Input

Typical Characteristics (continued)

At $T_A = 25^\circ\text{C}$, $V_{DD} = 3.3\text{ V}$, and $V_{IO} = 3.3\text{ V}$, unless otherwise noted.



7 Detailed Description

7.1 Overview

The SRC4192 and SRC4193 devices are asynchronous, sample-rate converters (ASRC) designed for professional audio applications. Operation at input and output sampling frequencies up to 212 kHz is supported, with an input and output sampling ratio range of 16:1 to 1:16. Excellent dynamic range and Total Harmonic Distortion + Noise (THD+N) are achieved by employing high-performance, linear-phase digital filtering with image rejection better than 140 dB. Digital filtering options allow for lower group-delay processing. These include a low group-delay option for the interpolation and resampler function, as well as a direct down-sampling option for the decimation function (SRC4193 device only).

The audio input and output ports support standard audio data formats, as well as a TDM interface mode. Word lengths of 24-, 20-, 18-, and 16-bits are supported. Both ports may operate in slave mode, deriving their word and bit clocks from external input and output devices. Alternatively, one port may operate in master mode while the other remains in slave mode. In master mode, the LRCK and BCK clocks are derived from the reference clock input, RCKI. The flexible configuration of the input and output ports allows connection to a wide variety of audio data converters, interface devices, digital signal processors, and programmable logic.

A bypass mode is included, which allows audio data to be passed directly from the input port to the output port, bypassing the ASRC function. The bypass option is useful for passing through encoded or compressed audio data, or nonaudio control or status data.

A soft mute function is available on both the SRC4192 and SRC4193 devices. Digital output attenuation is available only for the SRC4193 device. Both soft mute and digital attenuation functions provide artifact-free operation, while allowing muting or level adjustment of the audio output signal. The mute attenuation is typically –144 dB, while the digital attenuation control is adjustable from 0 dB to –127.5 dB in 0.5-dB steps.

The SRC4193 device includes a three-wire SPI port to access on-chip control registers for configuration of internal functions. The port can be easily interfaced to microprocessors or digital signal processors with synchronous serial port peripherals.

Functional Block Diagram shows a functional block diagram of the SRC4192 and SRC4193 devices. Audio data is received at the input port, clocked by either the audio data source in slave mode, or by the SRC419x in master mode. The output-port data is clocked by either the audio data source in slave mode, or by the SRC419x in master mode. The input data is passed through interpolation filters which up-sample the data, which is then passed on to the resampler. The rate estimator compares the input and output sampling frequencies by comparing LRCKI, LRCKO, and a reference clock. The results include an offset for the FIFO pointer and the coefficients needed for re-sampling function.

The output of the resampler is passed on to either the decimation filter or direct down-sampler function. The decimation filter performs down-sampling and anti-alias filtering functions, and is required when the output sampling frequency is lower than the input-sampling frequency. The direct down-sampler function does not provide any filtering, and may be used in cases when aliasing is not an issue. This includes the case when the output sampling frequency is equal to or greater than the input sampling frequency. The advantage of direct down-sampling is a significant reduction in the group delay associated with the decimation filter, allowing lower latency sample rate conversion. The direct down-sampler function is available only for the SRC4193 device.

7.2 Functional Block Diagram

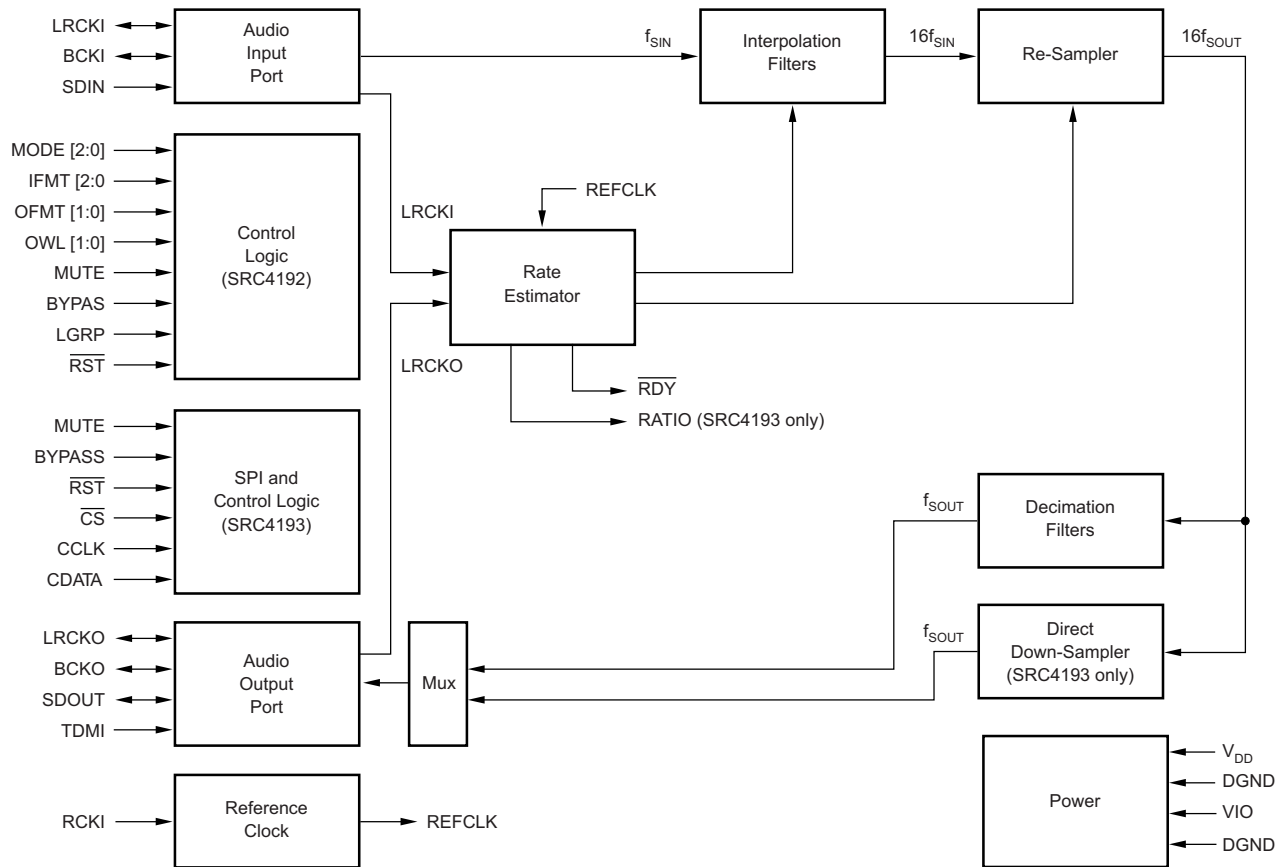

7.3 Feature Description

7.3.1 Input Port Operation

The audio input port is a three-wire synchronous serial interface that can operate in either slave or master mode. The SDIN input (pin 4) is the serial audio data input. Audio data is input at this pin in one of three standard audio data formats: Philips I²S, Left-Justified, or Right-Justified. The audio data word length may be up to 24-bits for I²S and Left-Justified formats, while the Right-Justified format supports 16-, 18-, 20-, or 24-bit data. The data formats are shown in [Figure 59](#), while critical timing parameters are shown in [Figure 60](#) and listed in [Electrical Characteristics](#).

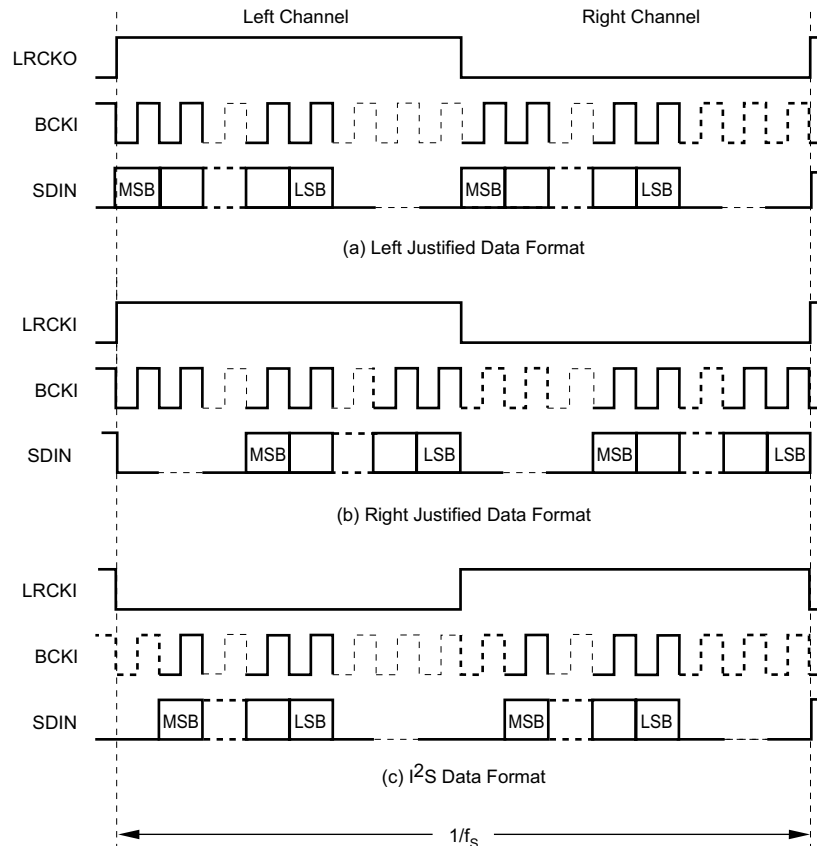
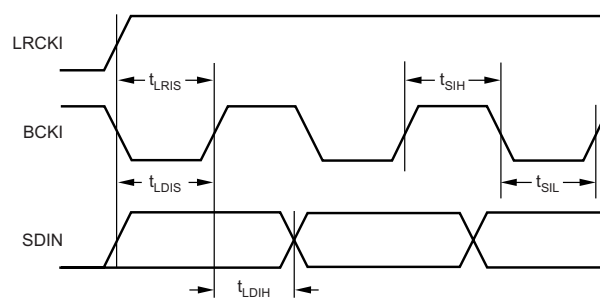
Feature Description (continued)

Figure 59. Input Data Formats

Figure 60. Input Port Timing

The bit clock is either an input or output at BCKI (pin 5). In slave mode, BCKI is configured as an input pin, and may operate at rates from $32f_s$ to $128f_s$, with a minimum of one clock cycle per data bit. In master mode, BCKI operates at a fixed rate of $64f_s$.

The left/right word clock, LRCKI (pin 6), may be configured as an input or output pin. In slave mode, LRCKI is an input pin, while in master mode LRCKI is an output pin. In either case, the clock rate is equal to f_s , the input sampling frequency. The LRCKI duty cycle is fixed to 50% for master mode operation.

Table 1 shows data format selection for the input port. For the SRC4192, the IFMT0 (pin 10), IFMT1 (pin 11), and IFMT2 (pin 12) inputs are used to set the input port data format. For the SRC4193, the IFMT[2:0] bits in Control Register 3 are used to select the data format.

Feature Description (continued)

Table 1. Input Port Data Format Selection

IFMT2	IFMT1	IFMT0	INPUT PORT DATA FORMAT
0	0	0	24-Bit Left Justified
0	0	1	24-Bit I ² S
0	1	0	Unused
0	1	1	Unused
1	0	0	16-Bit Right Justified
1	0	1	18-Bit Right Justified
1	1	0	20-Bit Right Justified
1	1	1	24-Bit Right Justified

7.3.2 Output Port Operation

The audio output port is a four-wire synchronous serial interface that can operate in either Slave or Master mode. The SDO_{OUT} output (pin 23) is the serial audio data output. Audio data is output at this pin in one of four data formats: Philips I²S, Left-Justified, Right-Justified, or TDM. The audio data word length may be 16-, 18-, 20-, or 24-bits. For all word lengths, the data is triangular PDF dithered from the internal 28-bit data path. The data formats (with the exception of TDM mode) are shown in Figure 61, while critical timing parameters are shown in Figure 62 and listed in *Electrical Characteristics*. The TDM format and timing are shown in Figure 72 and Figure 73, respectively, while examples of standard TDM configurations are shown in Figure 74 and Figure 75

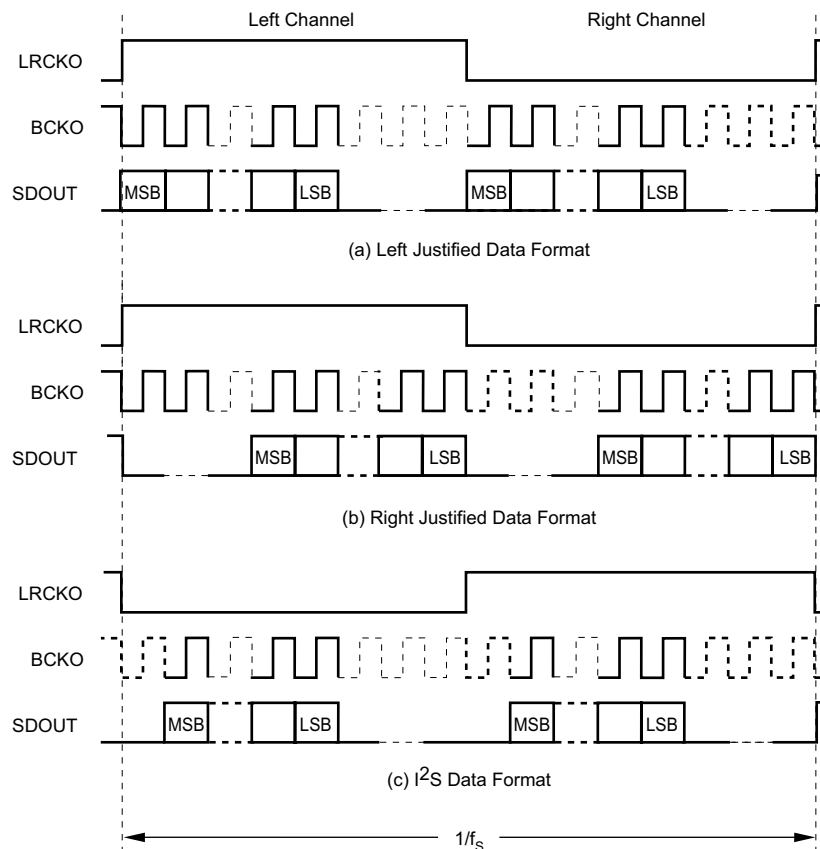
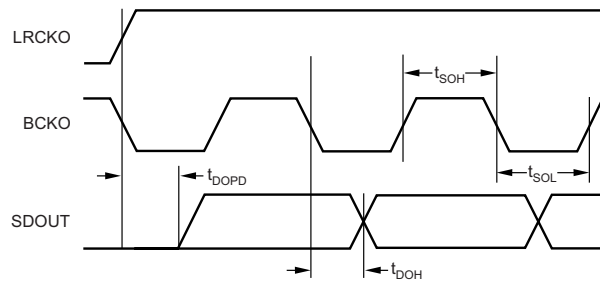

Figure 61. Output Data Formats

Figure 62. Output Port Timing

The bit clock is either input or output at BCKO (pin 25). In Slave mode, BCKO is configured as an input pin, and can operate at rates from $32f_s$ to $128f_s$, with a minimum of one clock cycle for each data bit. The exception is the TDM mode, where the BCKO must operate at $N \times 64f_s$, where N is equal to the number of SRC4192 or SRC4193 devices included on the TDM interface. In master mode, BCKO operates at a fixed rate of $64f_s$ for all data formats except TDM, where BCKO operates at the reference clock (RCKI) frequency. Additional information regarding TDM mode operation is included in [Application and Implementation](#).

The left/right word clock, LRCKO (pin 24), can be configured as an input or output pin. In slave mode, LRCKO is an input pin, while in master mode it is an output pin. In either case, the clock rate is equal to f_s , the output sampling frequency. The clock duty cycle is fixed to 50% for I²S, Left-Justified, and Right-Justified formats in master mode. The LRCKO pulse width is fixed to 32 BCKO cycles for the TDM format in master mode.

[Table 2](#) illustrates data format selection for the output port. For the SRC4192, the OFMT0 (pin 19), OFMT1 (pin 18), OWL0 (pin 17), and OWL1 (pin 16) inputs are used to set the output port data format and word length. For the SRC4193, the OFMT[1:0] and OWL[1:0] bits in Control Register 3 are used to select the data format and word length.

Table 2. Output Port Data Format Selection

OFMT1	OFMT0	OUTPUT PORT DATA FORMAT
0	0	Left-Justified
0	1	I ² S
1	0	TDM
1	1	Right-Justified
OWL1	OWL0	OUTPUT PORT DATA WORD LENGTH
0	0	24-Bits
0	1	20-Bits
1	0	18-Bits
1	1	16-Bits

7.3.3 Soft Mute Function

The soft mute function of the SRC419x device is invoked by forcing the MUTE input (pin 14) high. For the SRC4193 device, the mute function may also be accessed using the MUTE bit in Control Register 1. The soft mute function slowly attenuates the output signal level down to all zeroes plus ± 1 LSB of dither. This provides an artifact-free muting of the audio output port.

7.3.4 Digital Attenuation (SRC4193 Only)

The SRC4193 device includes independent digital attenuation for the left and right audio channels. The attenuation ranges from 0 dB (or unity) to -127.5 dB in 0.5-dB steps. The attenuation settings are programmed using Control Registers 4 and 5, corresponding to the left and right channels, respectively.

The TRACK bit in Control Register 1 selects independent or tracking attenuation modes. When TRACK = 0, the left and right channels are controlled independently. When TRACK = 1, the attenuation setting for the left channel is also used for the right channel, and the right channel is said to track the left channel attenuation setting.

Byte 0 indicates the address of the control register to be written. The two most significant bits are set to 0, while the six least significant bits contain the control register address. Byte 1 is a don't care byte. This byte is included in the protocol to maintain compatibility with current and future Texas Instruments digital audio products, including the DIT4096 and DIT4192 digital audio transmitters. Byte 2 contains the 8-bit data for the control register addressed in Byte 0.

As shown in [Figure 63](#), a write sequence starts by bringing the \overline{CS} input low. Bytes 0, 1, and 2 are then written to program a single control register. Bringing the \overline{CS} input high after the third byte will write just one register. However, if \overline{CS} remains low after writing the first control byte, the port will autoincrement the address by 1, allowing successive addresses to be written. The address is automatically incremented by 1 after each byte is written, as long as the \overline{CS} input remains low. This is referred to as auto-increment operation, and is always enabled for the SPI port.

7.4 Device Functional Modes

7.4.1 Reset and Power Down Operation

The SRC419x device can be reset using the \overline{RST} input (pin 13). There is no internal power-on reset, so the user should force a reset sequence after power up to initialize the device. To force a reset, the reference clock input must be active, with an external clock source supplying a valid reference clock signal (refer to [Figure 80](#)). The user must assert \overline{RST} low for a minimum of 500 ns, and then bring \overline{RST} high again to force a reset. [Figure 65](#) shows the reset timing for the SRC419x device.

For the SRC4193, there is an additional 500 μ s delay after the \overline{RST} rising edge, due to internal logic requirements. The customer should wait at least 500 μ s after the \overline{RST} rising edge before attempting to write to the SPI port of the SRC4193 device.

The SRC419x device also supports a power-down mode. Power-down mode may be set by either holding the \overline{RST} input low (SRC4192 and SRC4193 devices), or by setting the PDN bit in Control Register 1 to zero (SRC4193 device only). The SRC4193 device will be in power-down mode by default after an external reset has been issued. To enable normal operation for the SRC4193, disable power down mode by writing a 1 to the PDN bit in Control Register 1.

When using the PDN bit in Control Register 1 to enable power-down mode for the SRC4193, the current state of the control registers is maintained through the power-down and power-up transition.

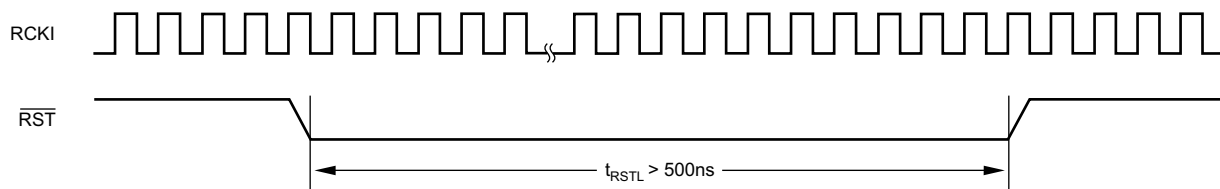

Figure 65. Reset Pulse Width Requirement

7.4.2 Audio Port Modes

The SRC4192 and SRC4193 devices both support seven serial-port modes, shown in [Table 3](#). For the SRC4192 device, the audio port mode is selected using the MODE0 (pin 26), MODE1 (pin 27), and MODE2 (pin 28) inputs. For the SRC4193 device, the mode is selected using the MODE[2:0] bits in Control Register 1. The default mode setting for the SRC4193 device is both input and output ports set to slave mode.

In slave mode, the port LRCK and BCK clocks are configured as inputs, and receive their clocks from an external audio device. In master mode, the LRCK and BCK clocks are configured as outputs, being derived from the reference clock input (RCKI). Only one port can be set to master mode at any given time, as indicated in [Table 3](#).

Table 3. Setting the Serial Port Modes

MODE2	MODE1	MODE0	SERIAL PORT MODE
0	0	0	Both Input and Output Ports are Slave mode
0	0	1	Output Port is Master mode with RCKI = 128 f _S
0	1	0	Output Port is Master mode with RCKI = 512 f _S

Device Functional Modes (continued)

Table 3. Setting the Serial Port Modes (continued)

MODE2	MODE1	MODE0	SERIAL PORT MODE
0	1	1	Output Port is Master mode with RCKI = 256 f _S
1	0	0	Both Input and Output Ports are Slave mode
1	0	1	Input Port is Master mode with RCKI = 128 f _S
1	1	0	Input Port is Master mode with RCKI = 512 f _S
1	1	1	Input Port is Master mode with RCKI = 256 f _S

7.4.3 Bypass Mode

The SRC419x device includes a bypass function, which routes the input port data directly to the output port bypassing the ASRC function. Bypass mode may be invoked by forcing the BYPAS input (pin 9) high for the devices. The bypass mode may also be accessed for the SRC4193 device using the BYPAS bit in Control Register 1. The BYPAS pin and control bit should be set to 0 for normal operation.

No dithering is applied to the output data in bypass mode, and the digital attenuation and mute functions are also unavailable.

7.5 Register Maps

7.5.1 Control Register Map (SRC4193 Device Only)

The control register map for the SRC4193 device is shown in [Table 4](#). Register 0 is reserved for factory use and defaults to all zeros upon reset. Avoid writing this register, as unexpected operation may result if Register 0 is programmed to an arbitrary value. Registers 1 through 5 contain control bits used to configure the internal functions of the SRC4193. All other register addresses are reserved and should not be used in customer applications.

Table 4. SRC4193 Device Control Register Map

Register Address (Dec/Hex)	D7 (MSB)	D6	D5	D4	D3	D2	D1	D0 (LSB)
0	0	0	0	0	0	0	0	0
1	$\overline{\text{PDN}}$	TRACK	0	MUTE	BYPAS	MODE2	MODE1	MODE0
2	0	0	0	0	0	0	DFLT	LGRP
3	OWL1	OWL0	OFMT1	OFMT0	0	IFMT2	IFMT1	IFMT0
4	AL7	AL6	AL5	AL4	AL3	AL2	AL1	AL0
5	AR7	AR6	AR5	AR4	AR3	AR2	AR1	AR0

7.5.1.1 System Control Register

Table 5. System Control Register Field Descriptions

Bit	Field	Description
7	PDN	Power Down Setting this bit to 0 sets the SRC4193 to the power-down state. All other register settings are preserved and the SPI port remains active. (Default) Setting this bit to 1 powers up the SRC4193 using the current register settings.
6	TRACK	Digital Attenuation Tracking 0 = Tracking Off: Attenuation for the Left and Right channels is controlled independently. (Default) 1 = Tracking On: Left channel attenuation setting is used for both channels.
5	Reserved	
4	MUTE	Output Soft Mute This bit is logically OR'd with the MUTE input (pin 14) 0 = Soft mute disabled (Default) 1 = Soft mute enabled with data attenuated to all 0s
3	BYPAS	Bypass Mode This bit is logically OR'd with the BYPAS input (pin 9) 0 = Bypass Mode disabled with normal ASRC operation. (Default) 1 = Bypass Mode enabled with data routed directly from the input port to the output port, bypassing the ARSC function.
2-0	MODEx	Audio Serial Port Mode See Table 3.

7.5.1.2 Filter Control Register

Figure 66. Filter Control Register

7	6	5	4	3	2	1	0
Reserved						DFLT	LGRP

LEGEND: R/W = Read/Write; R = Read only; -n = value after reset

Table 6. Filter Control Register Field Descriptions

Bit	Field	Description
7-2	Reserved	
1	DFLT	Decimation Filtering / Direct Down-Sampling The DFLT bit enables or disables the direct down-sampling function. 0 = Decimation filter enabled (default) (Must be used when f_{SOUT} is less than f_{SIN}) 1 = Direct down-sampling enabled without filtering. (May be enabled when f_{SOUT} is equal to or greater than f_{SIN})
0	LGRP	Low Group Delay This bit selects the number of input audio samples to be stored in the data buffer before the ASRC starts processing the audio data. 0 = Normal delay, 64 samples (default) 1 = Low delay, 32 samples

7.5.1.3 Audio Data Format Register

Figure 67. Audio Data Format Register

7	6	5	4	3	2	1	0
OWL1	OWL0	OFMT1	OFMT0	Reserved	IFMT2	IFMT1	IFMT0

LEGEND: R/W = Read/Write; R = Read only; -n = value after reset

Table 7. Audio Data Format Register Field Descriptions

Bit	Field	Description
7-6	OWLx	Output Port Data Word Length See Table 2 .
5-4	OFMTx	Output Port Data Format See Table 2 .
3	Reserved	
2-0	IFMTx	Input Port Data Format See Table 1 .

7.5.1.4 Digital Attenuation Register – Left Channel

Figure 68. Digital Attenuation Register – Left Channel

7	6	5	4	3	2	1	0
AL7	AL6	AL5	AL4	AL3	AL2	AL1	AL0

LEGEND: R/W = Read/Write; R = Read only; -n = value after reset

Table 8. Digital Attenuation Register – Left Channel Field Descriptions

Bit	Field	Description
7-0	ALx	Register defaults to 00 _{HEX} , or 0 dB (unity gain). Output Attenuation (dB) = $(-N \times 0.5)$, where $N = AL[7:0]_{DEC}$

7.5.1.5 Digital Attenuation Register – Right Channel

Figure 69. Digital Attenuation Register – Right Channel

7	6	5	4	3	2	1	0
AR7	AR6	AR5	AR4	AR3	AR2	AR1	AR0

LEGEND: R/W = Read/Write; R = Read only; -n = value after reset

Table 9. Digital Attenuation Register – Right Channel Field Descriptions

Bit	Field	Description
7-0	ARx	Register defaults to 00 _{HEX} , or 0 dB (unity gain). Output Attenuation (dB) = $(-N \times 0.5)$, where $N = AR[7:0]_{DEC}$ When the TRACK bit in Control Register 1 is set to 1, the Left Channel attenuation setting will be used for the Right Channel attenuation.

8 Application and Implementation

NOTE

Information in the following applications sections is not part of the TI component specification, and TI does not warrant its accuracy or completeness. TI's customers are responsible for determining suitability of components for their purposes. Customers should validate and test their design implementation to confirm system functionality.

8.1 Application Information

This section of the data sheet provides practical applications information for hardware and systems engineers designing the SRC4192 and SRC4193 devices into the end equipment.

8.1.1 Interfacing to Digital Audio Receivers and Transmitters

The input and output ports of the SRC4192 and SRC4193 devices are designed to interface to a variety of audio devices, including receivers and transmitters commonly used for AES/EBU, S/PDIF, and CP1201 communications.

Texas Instruments manufactures the DIR1703 digital audio interface receiver and DIT4096/4192 digital audio transmitters to address these applications.

Figure 70 shows interfacing the DIR1703 device to the input port of the SRC4192 or SRC4193 device. The DIR1703 device operates from a single 3.3-V supply, which requires the V_{IO} supply (pin 7) for the SRC4192 or SRC4193 device to be set to 3.3 V for interface compatibility.

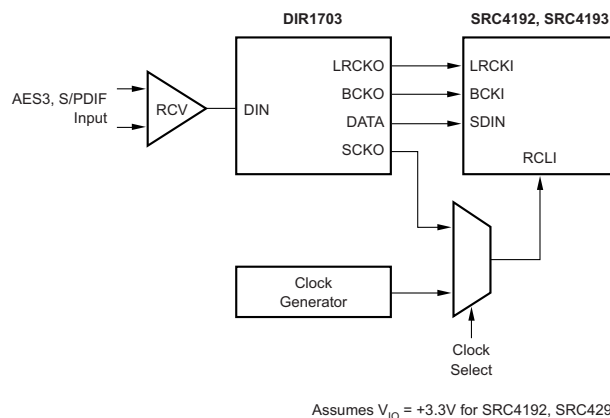
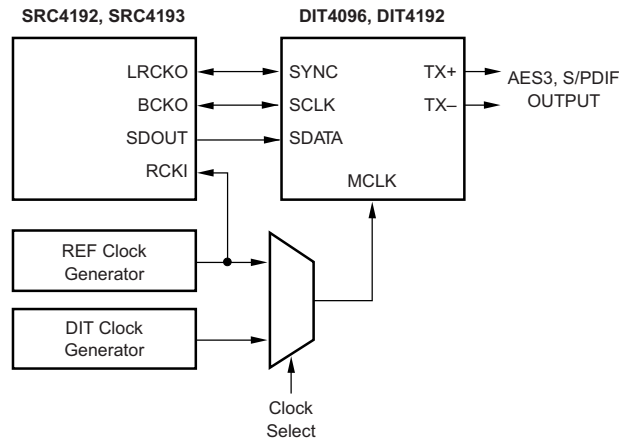

Figure 70. Interfacing the SRC4193 to the DIR1703 Digital Audio Interface Receiver

Figure 71 shows the interface between the output port of the SRC4192 or SRC4193 device and the audio serial port of the DIT4096 or DIT4192 device. Again, the V_{IO} supplies for both the SRC419x device and DIT4096/4192 device are set to 3.3 V for compatibility.

Application Information (continued)



Assumes $V_{IO} = +3.3V$ for SRC4192, SRC4293 and DIT4096, DIT4192

Figure 71. Interfacing the SRC4193 to the DIT4096/4192 Digital Audio Interface Transmitter

Like the output port of the SRC4192 or SRC4193 device, the audio serial port of the DIT4096 and DIT4192 device can be configured as a master or slave. In cases where the output port of the SRC419x device is set to master mode, use the reference clock source (RCKI) as the master clock source (MCLK) for the DIT4096/4192 device, to ensure that the transmitter is synchronized to the output port data of the SRC419x device.

8.1.2 TDM Applications

The SRC4192 and SRC4193 devices support a TDM output mode, which allows multiple devices to be daisy-chained together to create a serial frame. Each device occupies one subframe within a frame, and each sub-frame carries two channels (Left followed by Right). Each sub-frame is 64 bits long, with 32 bits allotted for each channel. The audio data for each channel is left justified within the allotted 32 bits. Figure 72 shows the TDM frame format, while Figure 73 shows TDM input timing parameters, which are listed in *Electrical Characteristics*.

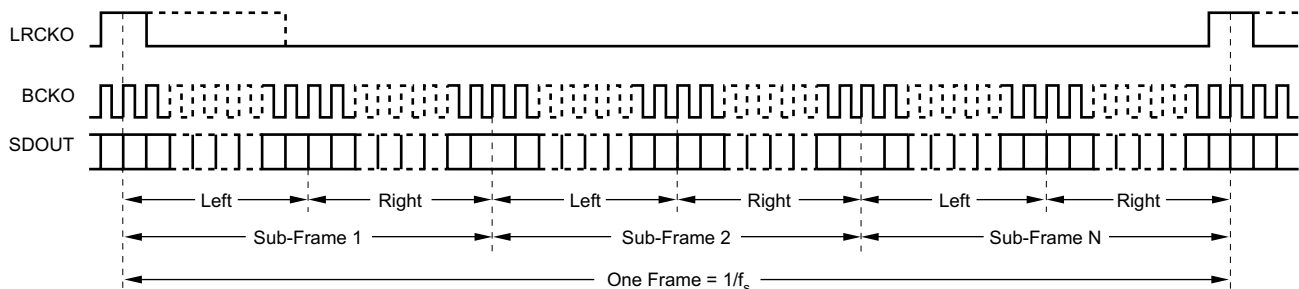

N = Number of Daisy-Chained Devices
 One Sub-Frame contains 64 bits, with 32 bits per channel.
 For each channel, the audio data is left justified, MSB first format, with the word length determined by the OWL[1:0] pins/bits.

Figure 72. TDM Frame Format

Application Information (continued)

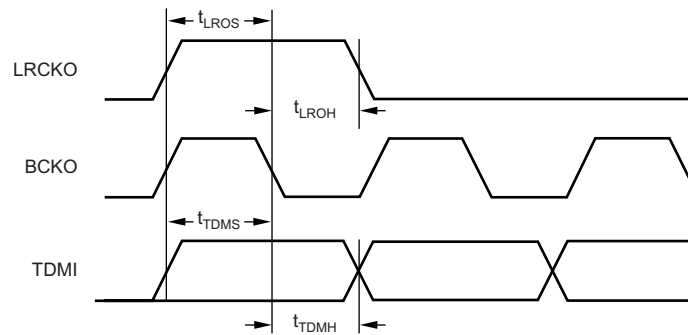

Figure 73. Input Timing for TDM Mode

The frame rate is equal to the output sampling frequency, f_s . The BCKO frequency for the TDM interface is $N \times 64f_s$, where N is the number of devices included in the daisy chain. For Master mode, the output BCKO frequency is fixed to the reference clock (RCKI) input frequency. The number of devices that can be daisy-chained in TDM mode is dependent upon the output sampling frequency and the BCKO frequency, leading to the following numerical relationship:

$$\text{Number of Daisy-Chained Devices} = (f_{\text{BCKO}} / f_s) / 64$$

where

- f_{BCKO} = Output Port Bit Clock (BCKO), 27.648-MHz maximum
- f_s = Output Port Sampling (or LRCKO) Frequency, 216-kHz maximum. (1)

This relationship holds true for both slave and master modes.

Figure 74 and Figure 75 show typical connection schemes for TDM mode. Although the TMS320C671x DSP device family is shown as the audio processing engine in these figures, other TI digital signal processors with a multi-channel buffered serial port (McBSPTM) may also function with this arrangement. Interfacing to processors from other manufacturers is also possible. Refer to Figure 62 in this data sheet, along with the equivalent serial port timing diagrams shown in the DSP data sheet, to determine compatibility.

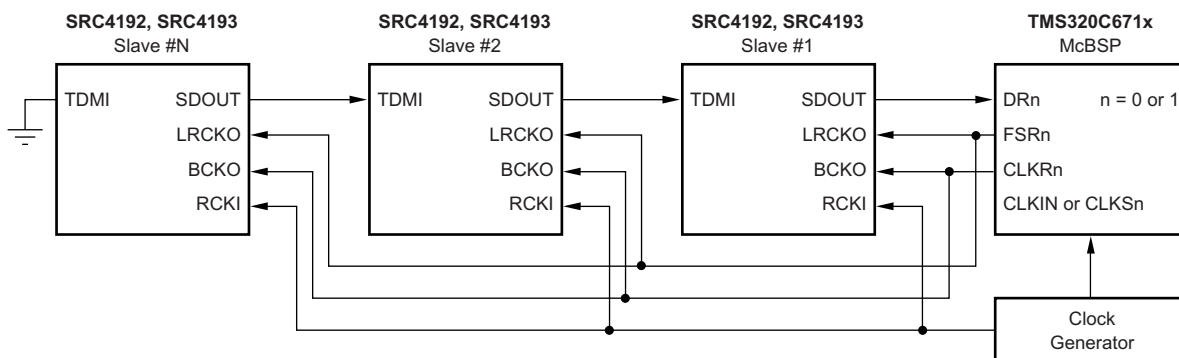

Figure 74. TDM Interface where all Devices are Slaves

Application Information (continued)

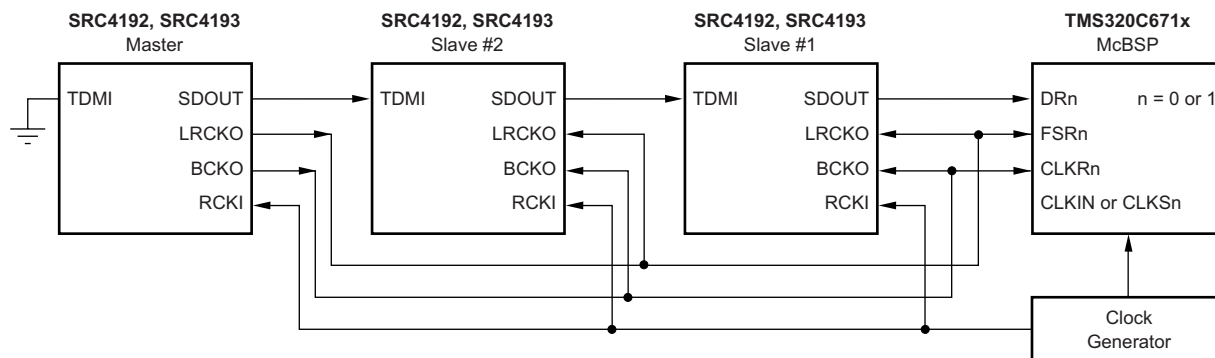

Figure 75. TDM Interface where one Device is Master to Multiple Slaves

8.2 Typical Application

Figure 76 and Figure 77 show typical connection diagrams for the SRC4192 and SRC4193 devices (respectively). Recommended values for power supply bypass capacitors are included. These capacitors should be placed as close to the IC package as possible.

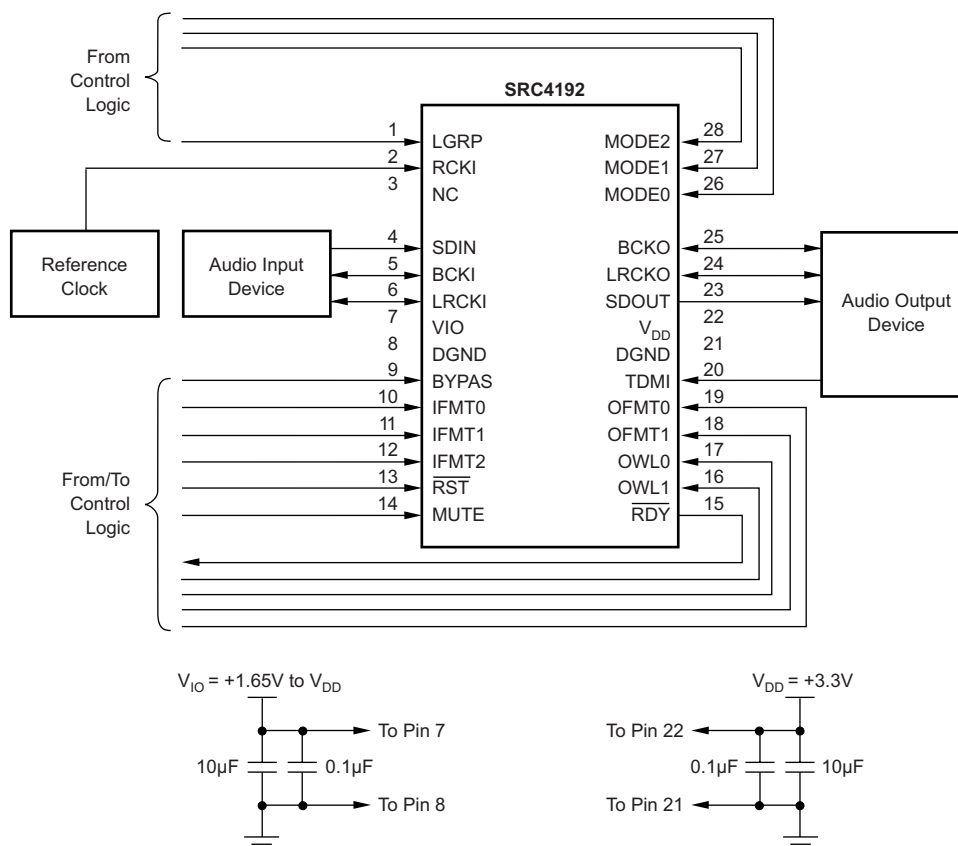
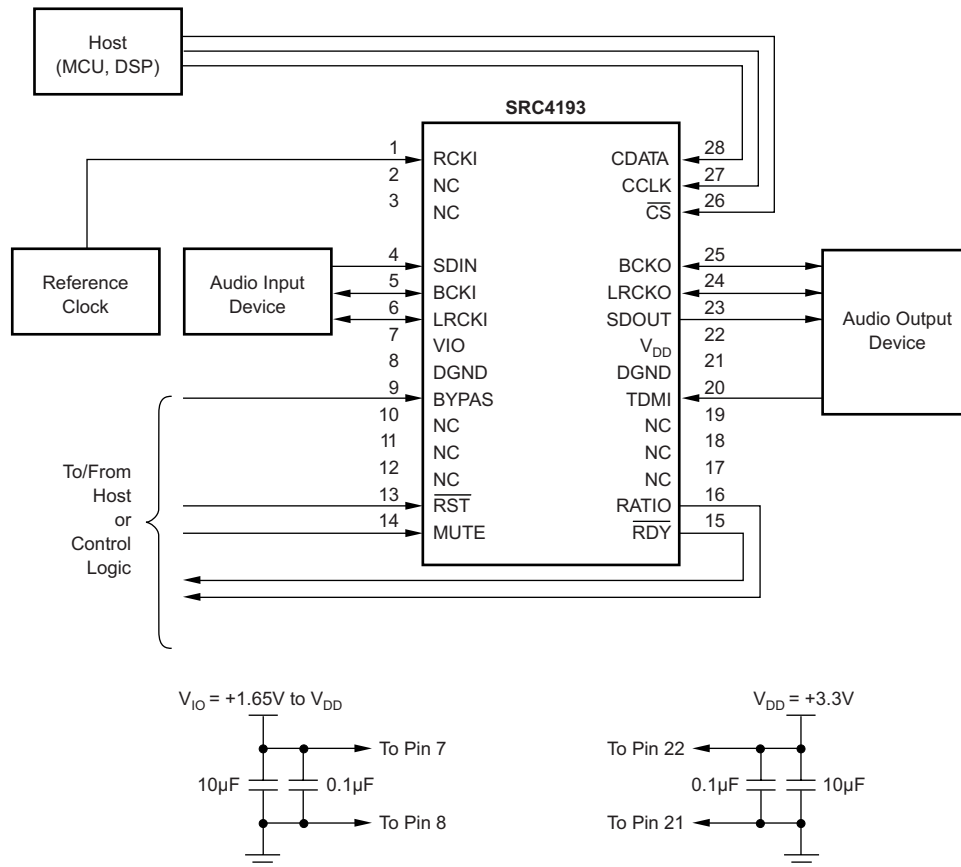

Figure 76. Typical Connection Diagram for the SRC4192

Typical Application (continued)

Figure 77. Typical Connection Diagram for the SRC4193
8.2.1 Design Requirements

The following lists design requirements:

- Control: Hardware, I²C, or SPI
- Audio input: PCM serial data
- Audio output: PCM serial data
- Reference clock

8.2.2 Detailed Design Procedure
8.2.2.1 Control Method

The SRC4192 is a hardware controlled device while the SRC4193 is a software controlled device. The SRC4192 control pins can be connected to V_{DD} or GND directly or by the GPIO of a host controller. The SRC4193 can communicate over a 3 wire SPI.

8.2.2.2 Audio Input and Output

The Audio input and output ports can handle 16, 18, 20, or 24 bit right justified PCM serial data as well as 24 bit I2S or left justified PCM serial data at up to a 212-kHz sampling rate. A TDM format is also available. Both input and output can operate in slave mode, or one can operate as master while the other operates as a slave. A 16:1 or 1:16 is the max ratio supported between the input and output audio sampling rates.

Typical Application (continued)

8.2.3 Application Curves

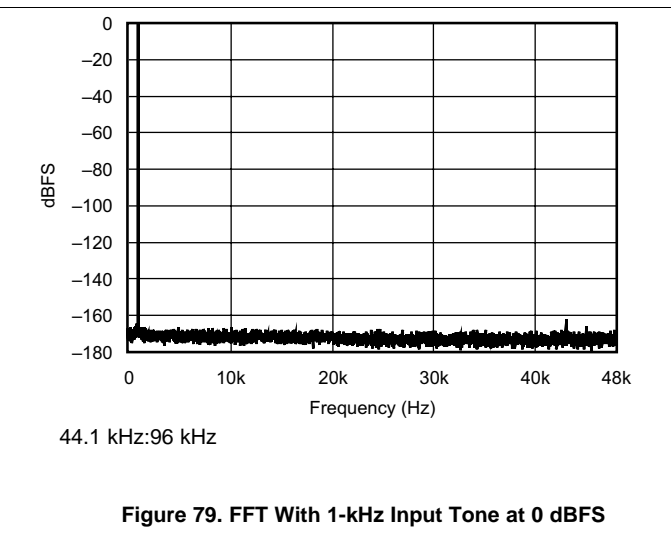
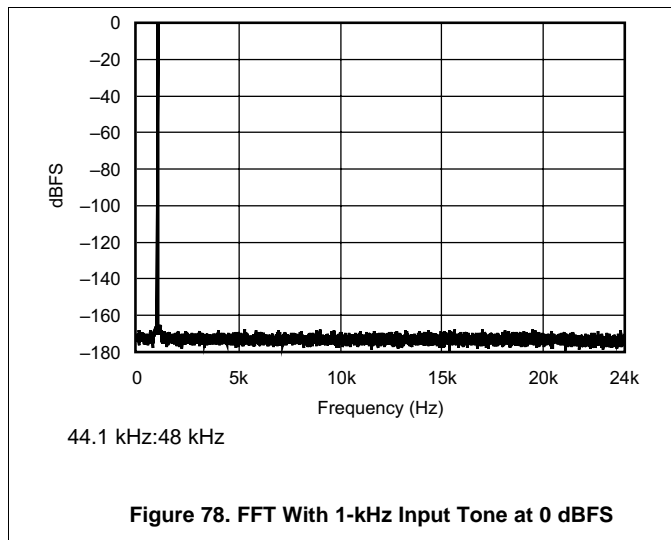

9 Power Supply Recommendations

To ensure compatibility, the VDD_IO and VDD_CORE supplies of the AD1896 device must be set to 3.3 V, while the V_{IO} and V_{DD} supplies of the SRC4192 device must be set to 3.3 V.

10 Layout

10.1 Layout Guidelines

10.1.1 Reference Clock

The SRC4192 and SRC4193 devices require a reference clock for operation. The reference clock is applied at the RCKI input (pin 1 for the SRC4193 device, pin 2 for the SRC4192 device). Figure 80 shows the reference clock connections and requirements for the SRC4192 and SRC4193 devices. The reference clock may operate at 128f_s, 256f_s, or 512f_s, where f_s are the input or output sampling frequency. The maximum external reference clock input frequency is 50 MHz.

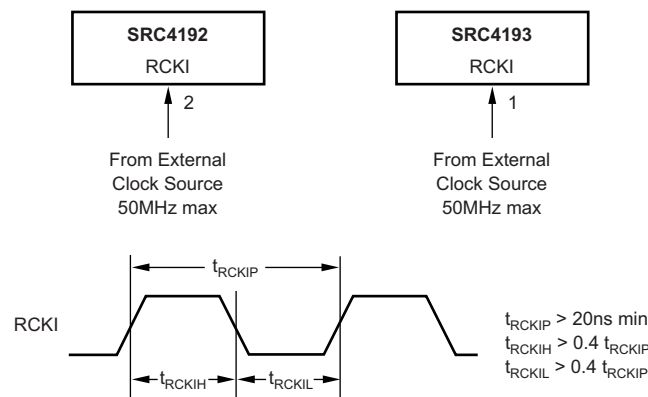

Figure 80. Reference Clock Input Connections and Timing Requirements

Layout Guidelines (continued)

10.1.2 Pin Compatibility With the Analog Devices AD1896 (SRC4192 Only)

The SRC4192 device is pin-and function-compatible with the AD1896 device when observing the guidelines indicated in the following paragraphs.

10.1.2.1 Crystal Oscillator

The SRC4192 does not have an on-chip crystal oscillator. An external reference clock is required at the RCKI input (pin 2).

10.1.2.2 Reference Clock Frequency

The reference clock input frequency for the SRC4192 must be no higher than 30 MHz, to match the master clock frequency specification of the AD1896 device. In addition, the SRC4192 device does not support the $768f_s$ reference clock rate.

10.1.2.3 Master Mode Maximum Sampling Frequency

When the input or output ports are set to master mode, the maximum sampling frequency must be limited to 96 kHz to support the AD1896 device specification. This is despite the fact that the SRC4192 device supports a maximum sampling frequency of 212 kHz in master mode. The user should consider building an option into their design to support the higher sampling frequency of the SRC4192 device.

10.1.2.4 Matched Phase Mode

Because of the internal architecture of the SRC4192 device, it does not require or support the matched phase mode of the AD1896 device. Given multiple SRC4192 devices, if all reference clock (RCKI) inputs are driven from the same clock source, the devices will be phase-matched.

10.2 Layout Example

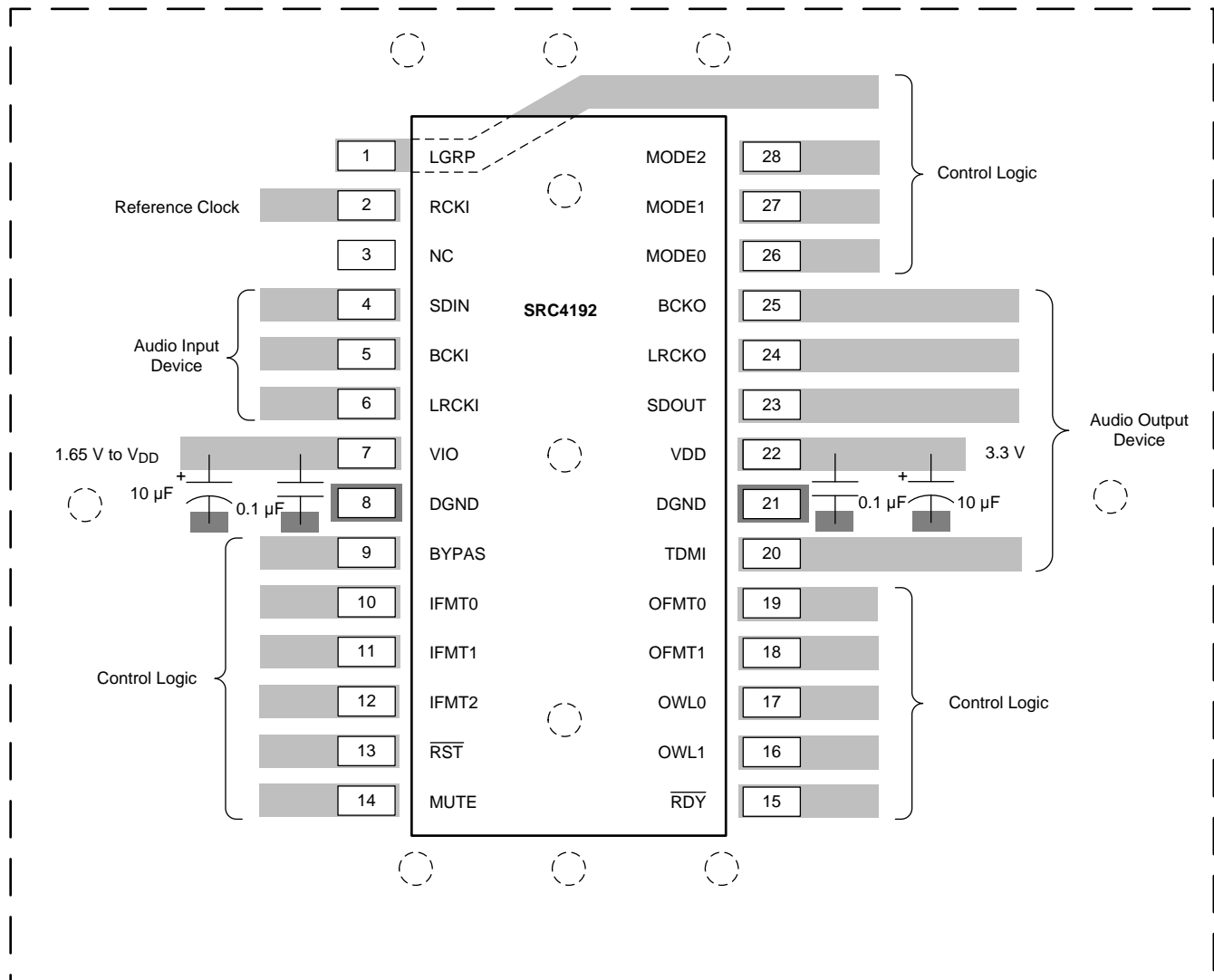

(1) TI recommends placing a top-layer ground pour for shielding around the SRC4192 device and connecting it to the lower main PCB-ground plane with multiple vias.

Figure 81. SRC4192 Layout Example

Layout Example (continued)

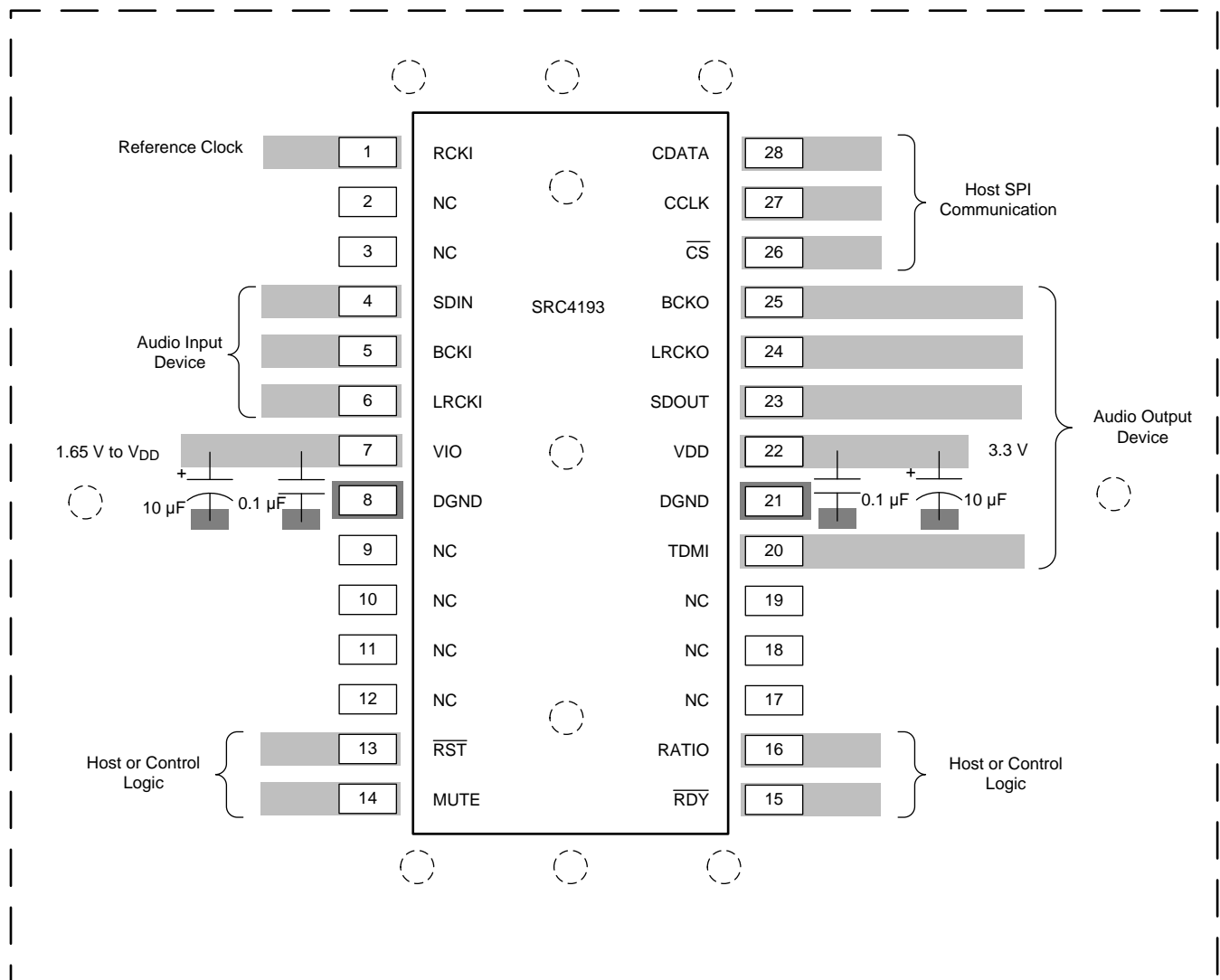

Top layer ground pour⁽¹⁾

Via to bottom ground plane

Top layer signal traces

Pad to top layer ground pour

(1) TI recommends placing a top-layer ground pour for shielding around the SRC4193 device and connecting it to the lower main PCB-ground plane with multiple vias.

Figure 82. SRC4193 Layout Example

11 Device and Documentation Support

11.1 Documentation Support

11.1.1 Related Documentation

For related documentation, see the following: *SRC4192EVM Evaluation Module*, [SBAU088](#)

11.2 Related Links

The table below lists quick access links. Categories include technical documents, support and community resources, tools and software, and quick access to sample or buy.

Table 10. Related Links

PARTS	PRODUCT FOLDER	SAMPLE & BUY	TECHNICAL DOCUMENTS	TOOLS & SOFTWARE	SUPPORT & COMMUNITY
SRC4192	Click here	Click here	Click here	Click here	Click here
SRC4193	Click here	Click here	Click here	Click here	Click here

11.3 Community Resources

The following links connect to TI community resources. Linked contents are provided "AS IS" by the respective contributors. They do not constitute TI specifications and do not necessarily reflect TI's views; see TI's [Terms of Use](#).

TI E2E™ Online Community *TI's Engineer-to-Engineer (E2E) Community*. Created to foster collaboration among engineers. At e2e.ti.com, you can ask questions, share knowledge, explore ideas and help solve problems with fellow engineers.

Design Support *TI's Design Support* Quickly find helpful E2E forums along with design support tools and contact information for technical support.

11.4 Trademarks

E2E is a trademark of Texas Instruments.
All other trademarks are the property of their respective owners.

11.5 Electrostatic Discharge Caution



These devices have limited built-in ESD protection. The leads should be shorted together or the device placed in conductive foam during storage or handling to prevent electrostatic damage to the MOS gates.

11.6 Glossary

[SLYZ022](#) — *TI Glossary*.

This glossary lists and explains terms, acronyms, and definitions.

12 Mechanical, Packaging, and Orderable Information

The following pages include mechanical, packaging, and orderable information. This information is the most current data available for the designated devices. This data is subject to change without notice and revision of this document. For browser-based versions of this data sheet, refer to the left-hand navigation.

PACKAGING INFORMATION

Orderable part number	Status (1)	Material type (2)	Package Pins	Package qty Carrier	RoHS (3)	Lead finish/ Ball material (4)	MSL rating/ Peak reflow (5)	Op temp (°C)	Part marking (6)
SRC4192IDB	Active	Production	SSOP (DB) 28	50 TUBE	Yes	NIPDAU	Level-1-260C-UNLIM	-40 to 85	SRC4192I
SRC4192IDB.A	Active	Production	SSOP (DB) 28	50 TUBE	Yes	NIPDAU	Level-1-260C-UNLIM	-40 to 85	SRC4192I
SRC4192IDBR	Active	Production	SSOP (DB) 28	2000 LARGE T&R	Yes	NIPDAU	Level-1-260C-UNLIM	-40 to 85	SRC4192I
SRC4192IDBR.A	Active	Production	SSOP (DB) 28	2000 LARGE T&R	Yes	NIPDAU	Level-1-260C-UNLIM	-40 to 85	SRC4192I
SRC4192IDBRG4	Active	Production	SSOP (DB) 28	2000 LARGE T&R	Yes	NIPDAU	Level-1-260C-UNLIM	-40 to 85	SRC4192I
SRC4193IDB	Active	Production	SSOP (DB) 28	50 TUBE	Yes	NIPDAU	Level-1-260C-UNLIM	-40 to 85	SRC4193I
SRC4193IDB.A	Active	Production	SSOP (DB) 28	50 TUBE	Yes	NIPDAU	Level-1-260C-UNLIM	-40 to 85	SRC4193I
SRC4193IDBR	Active	Production	SSOP (DB) 28	2000 LARGE T&R	Yes	NIPDAU	Level-1-260C-UNLIM	-40 to 85	SRC4193I
SRC4193IDBR.A	Active	Production	SSOP (DB) 28	2000 LARGE T&R	Yes	NIPDAU	Level-1-260C-UNLIM	-40 to 85	SRC4193I

(1) **Status:** For more details on status, see our [product life cycle](#).

(2) **Material type:** When designated, preproduction parts are prototypes/experimental devices, and are not yet approved or released for full production. Testing and final process, including without limitation quality assurance, reliability performance testing, and/or process qualification, may not yet be complete, and this item is subject to further changes or possible discontinuation. If available for ordering, purchases will be subject to an additional waiver at checkout, and are intended for early internal evaluation purposes only. These items are sold without warranties of any kind.

(3) **RoHS values:** Yes, No, RoHS Exempt. See the [TI RoHS Statement](#) for additional information and value definition.

(4) **Lead finish/Ball material:** Parts may have multiple material finish options. Finish options are separated by a vertical ruled line. Lead finish/Ball material values may wrap to two lines if the finish value exceeds the maximum column width.

(5) **MSL rating/Peak reflow:** The moisture sensitivity level ratings and peak solder (reflow) temperatures. In the event that a part has multiple moisture sensitivity ratings, only the lowest level per JEDEC standards is shown. Refer to the shipping label for the actual reflow temperature that will be used to mount the part to the printed circuit board.

(6) **Part marking:** There may be an additional marking, which relates to the logo, the lot trace code information, or the environmental category of the part.

Multiple part markings will be inside parentheses. Only one part marking contained in parentheses and separated by a "-" will appear on a part. If a line is indented then it is a continuation of the previous line and the two combined represent the entire part marking for that device.

Important Information and Disclaimer: The information provided on this page represents TI's knowledge and belief as of the date that it is provided. TI bases its knowledge and belief on information provided by third parties, and makes no representation or warranty as to the accuracy of such information. Efforts are underway to better integrate information from third parties. TI has taken and continues to take reasonable steps to provide representative

and accurate information but may not have conducted destructive testing or chemical analysis on incoming materials and chemicals. TI and TI suppliers consider certain information to be proprietary, and thus CAS numbers and other limited information may not be available for release.

In no event shall TI's liability arising out of such information exceed the total purchase price of the TI part(s) at issue in this document sold by TI to Customer on an annual basis.

TAPE AND REEL INFORMATION

QUADRANT ASSIGNMENTS FOR PIN 1 ORIENTATION IN TAPE



*All dimensions are nominal

Device	Package Type	Package Drawing	Pins	SPQ	Reel Diameter (mm)	Reel Width W1 (mm)	A0 (mm)	B0 (mm)	K0 (mm)	P1 (mm)	W (mm)	Pin1 Quadrant
SRC4192IDBR	SSOP	DB	28	2000	330.0	16.4	8.1	10.4	2.5	12.0	16.0	Q1
SRC4193IDBR	SSOP	DB	28	2000	330.0	16.4	8.1	10.4	2.5	12.0	16.0	Q1

TAPE AND REEL BOX DIMENSIONS

*All dimensions are nominal

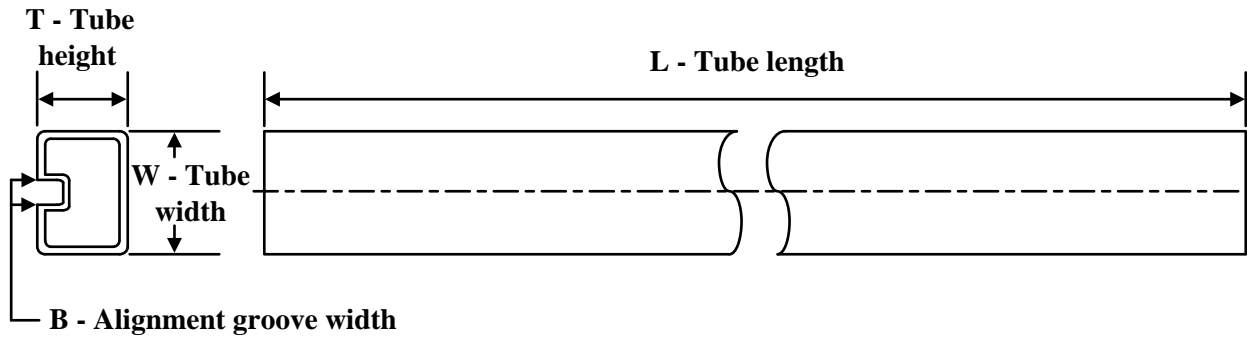
Device	Package Type	Package Drawing	Pins	SPQ	Length (mm)	Width (mm)	Height (mm)
SRC4192IDBR	SSOP	DB	28	2000	350.0	350.0	43.0
SRC4193IDBR	SSOP	DB	28	2000	350.0	350.0	43.0

TUBE

*All dimensions are nominal

Device	Package Name	Package Type	Pins	SPQ	L (mm)	W (mm)	T (μm)	B (mm)
SRC4192IDB	DB	SSOP	28	50	530	10.5	4000	4.1
SRC4192IDB	DB	SSOP	28	50	530	10.5	4000	4.1
SRC4192IDB.A	DB	SSOP	28	50	530	10.5	4000	4.1
SRC4192IDB.A	DB	SSOP	28	50	530	10.5	4000	4.1
SRC4192IDBR	DB	SSOP	28	2000	530	10.5	4000	4.1
SRC4192IDBR.A	DB	SSOP	28	2000	530	10.5	4000	4.1
SRC4192IDBRG4	DB	SSOP	28	2000	530	10.5	4000	4.1
SRC4193IDB	DB	SSOP	28	50	530	10.5	4000	4.1
SRC4193IDB	DB	SSOP	28	50	530	10.5	4000	4.1
SRC4193IDB.A	DB	SSOP	28	50	530	10.5	4000	4.1
SRC4193IDB.A	DB	SSOP	28	50	530	10.5	4000	4.1
SRC4193IDBR	DB	SSOP	28	2000	530	10.5	4000	4.1
SRC4193IDBR.A	DB	SSOP	28	2000	530	10.5	4000	4.1

DB0028A

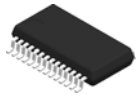

PACKAGE OUTLINE

SSOP - 2 mm max height

SMALL OUTLINE PACKAGE

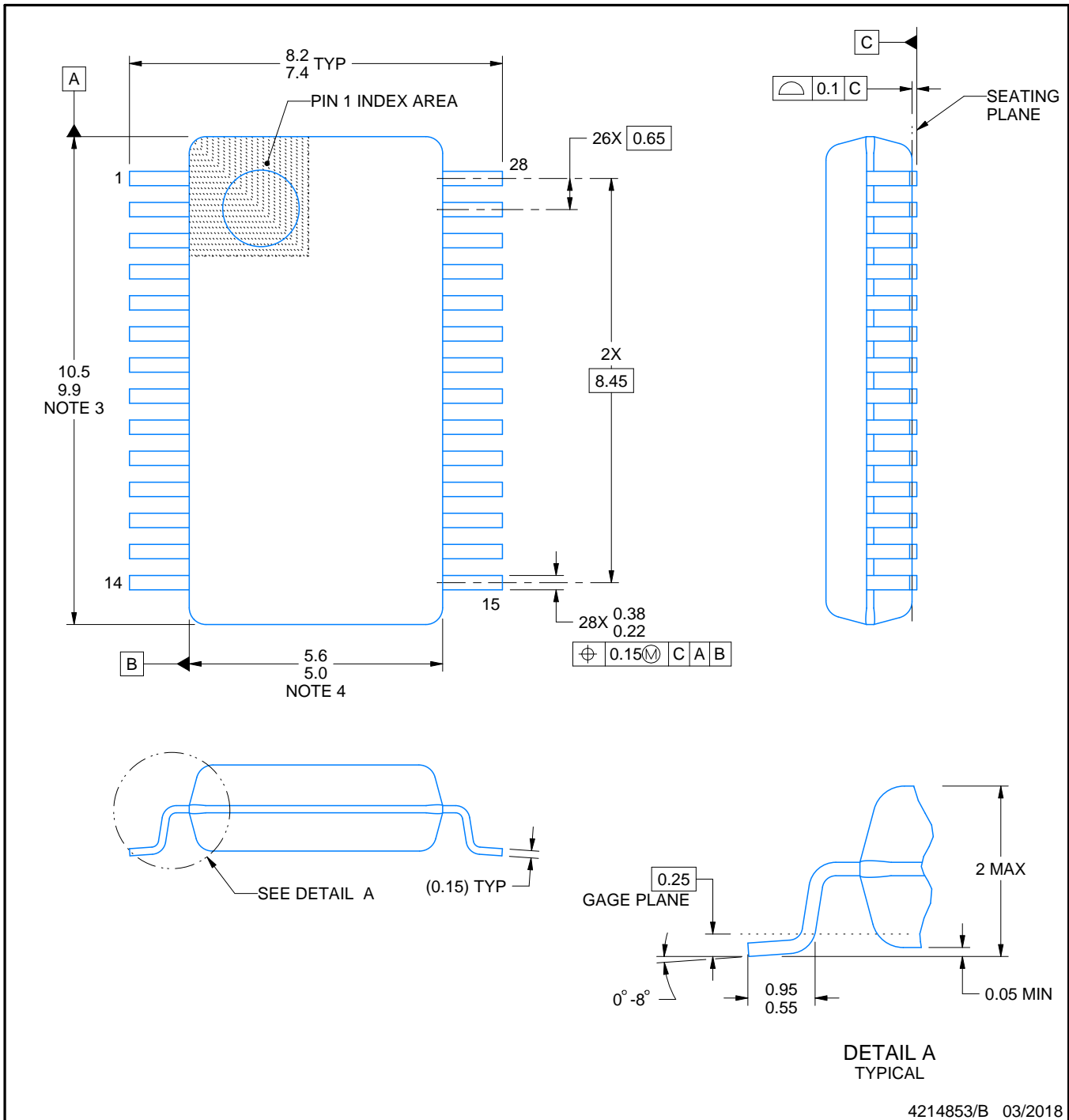

NOTES:

1. All linear dimensions are in millimeters. Any dimensions in parenthesis are for reference only. Dimensioning and tolerancing per ASME Y14.5M.
2. This drawing is subject to change without notice.
3. This dimension does not include mold flash, protrusions, or gate burrs. Mold flash, protrusions, or gate burrs shall not exceed 0.15 mm per side.
4. This dimension does not include interlead flash. Interlead flash shall not exceed 0.25 mm per side.
5. Reference JEDEC registration MO-150.

EXAMPLE BOARD LAYOUT

DB0028A

SSOP - 2 mm max height

SMALL OUTLINE PACKAGE

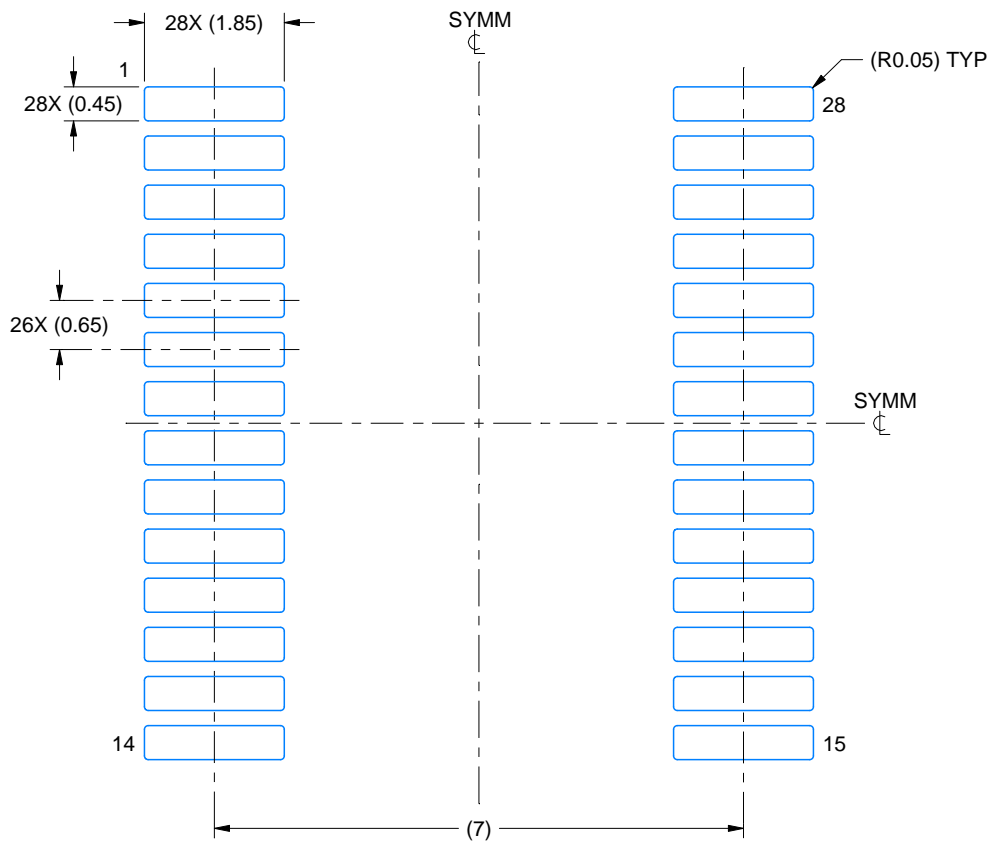

LAND PATTERN EXAMPLE
EXPOSED METAL SHOWN
SCALE: 10X

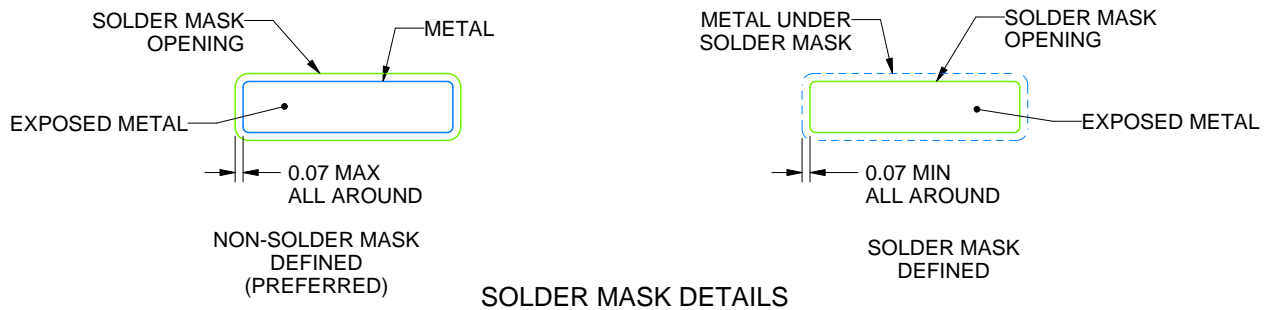

SOLDER MASK DETAILS

4214853/B 03/2018

NOTES: (continued)

- 6. Publication IPC-7351 may have alternate designs.
- 7. Solder mask tolerances between and around signal pads can vary based on board fabrication site.

EXAMPLE STENCIL DESIGN

DB0028A

SSOP - 2 mm max height

SMALL OUTLINE PACKAGE

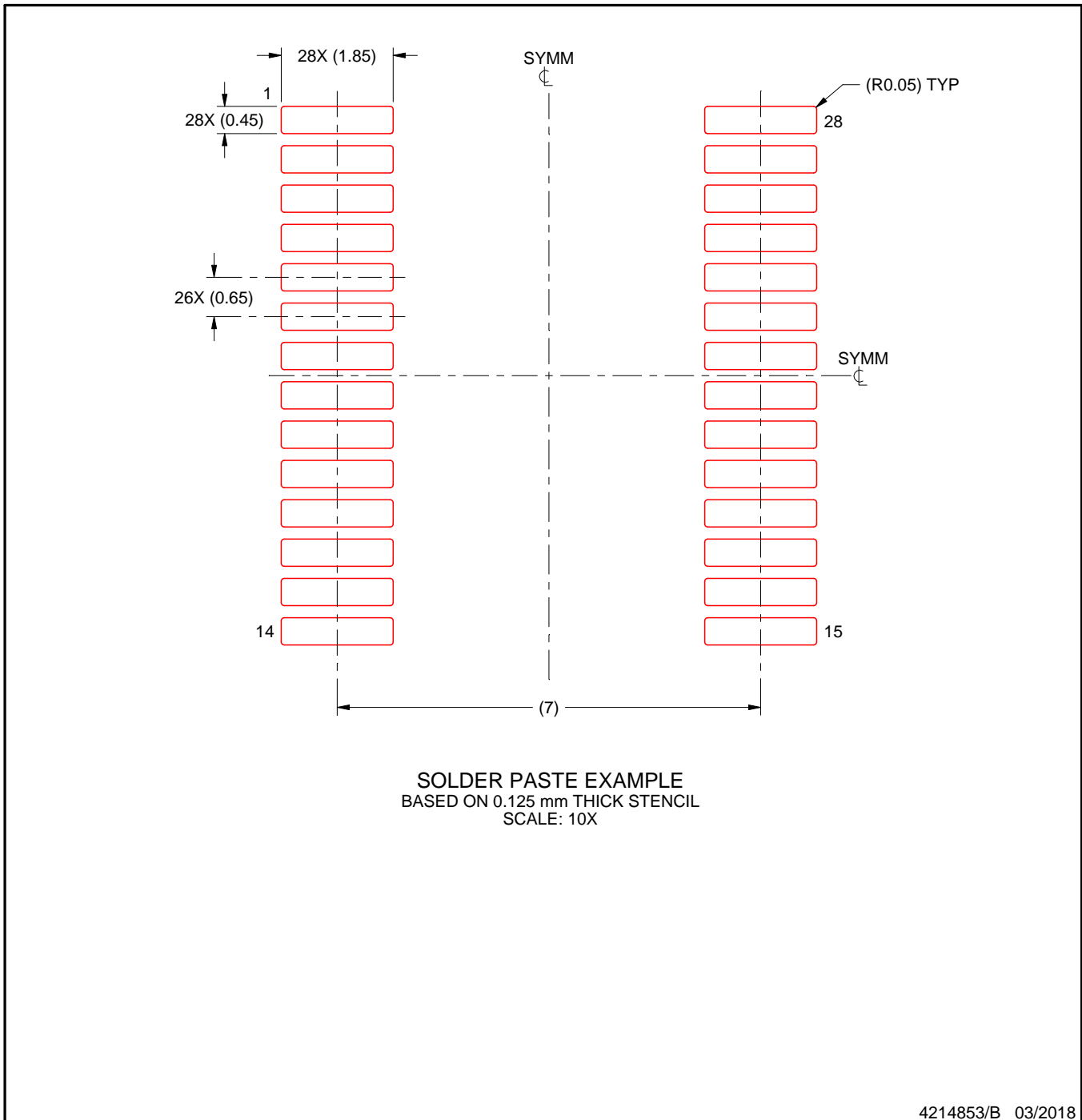

NOTES: (continued)

8. Laser cutting apertures with trapezoidal walls and rounded corners may offer better paste release. IPC-7525 may have alternate design recommendations.
9. Board assembly site may have different recommendations for stencil design.

IMPORTANT NOTICE AND DISCLAIMER

TI PROVIDES TECHNICAL AND RELIABILITY DATA (INCLUDING DATASHEETS), DESIGN RESOURCES (INCLUDING REFERENCE DESIGNS), APPLICATION OR OTHER DESIGN ADVICE, WEB TOOLS, SAFETY INFORMATION, AND OTHER RESOURCES "AS IS" AND WITH ALL FAULTS, AND DISCLAIMS ALL WARRANTIES, EXPRESS AND IMPLIED, INCLUDING WITHOUT LIMITATION ANY IMPLIED WARRANTIES OF MERCHANTABILITY, FITNESS FOR A PARTICULAR PURPOSE OR NON-INFRINGEMENT OF THIRD PARTY INTELLECTUAL PROPERTY RIGHTS.

These resources are intended for skilled developers designing with TI products. You are solely responsible for (1) selecting the appropriate TI products for your application, (2) designing, validating and testing your application, and (3) ensuring your application meets applicable standards, and any other safety, security, regulatory or other requirements.

These resources are subject to change without notice. TI grants you permission to use these resources only for development of an application that uses the TI products described in the resource. Other reproduction and display of these resources is prohibited. No license is granted to any other TI intellectual property right or to any third party intellectual property right. TI disclaims responsibility for, and you fully indemnify TI and its representatives against any claims, damages, costs, losses, and liabilities arising out of your use of these resources.

TI's products are provided subject to [TI's Terms of Sale](#), [TI's General Quality Guidelines](#), or other applicable terms available either on ti.com or provided in conjunction with such TI products. TI's provision of these resources does not expand or otherwise alter TI's applicable warranties or warranty disclaimers for TI products. Unless TI explicitly designates a product as custom or customer-specified, TI products are standard, catalog, general purpose devices.

TI objects to and rejects any additional or different terms you may propose.

Copyright © 2026, Texas Instruments Incorporated

Last updated 10/2025