

- Temperature Compensated
- Programmable Output Voltage
- Low Output Resistance
- Low Output Noise
- Sink Capability up to 100 mA

LP PACKAGE
(TOP VIEW)

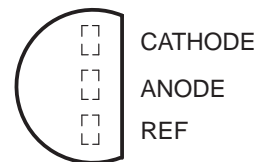

description/ordering information

The TL430 is a 3-terminal adjustable shunt regulator, featuring excellent temperature stability, wide operating current range, and low output noise. The output voltage can be set by two external resistors to any desired value between 3 V and 30 V. The TL430 can replace Zener diodes in many applications, providing improved performance.

The TL430C is characterized for operation from 0°C to 70°C.

ORDERING INFORMATION

T _A	PACKAGE†	ORDERABLE PART NUMBER	TOP-SIDE MARKING
0°C to 70°C	TO-226 / TO-92 (LP)	Bulk of 1000	TL430CLP
		Reel of 2000	TL430CLPR
			TL430C

† Package drawings, standard packing quantities, thermal data, symbolization, and PCB design guidelines are available at www.ti.com/sc/package.

symbol



Please be aware that an important notice concerning availability, standard warranty, and use in critical applications of Texas Instruments semiconductor products and disclaimers thereto appears at the end of this data sheet.

PRODUCTION DATA information is current as of publication date. Products conform to specifications per the terms of Texas Instruments standard warranty. Production processing does not necessarily include testing of all parameters.

**TEXAS
INSTRUMENTS**

POST OFFICE BOX 655303 • DALLAS, TEXAS 75265

Copyright © 2005, Texas Instruments Incorporated

TL430

ADJUSTABLE SHUNT REGULATORS

SLVS050D – JUNE 1976 – REVISED JANUARY 2005

absolute maximum ratings over operating free-air temperature range (unless otherwise noted)†

Regulator voltage (see Note 1)	30 V
Continuous regulator current	150 mA
Package thermal impedance, θ_{JA} (see Notes 2 and 3)	140°C/W
Operating virtual junction temperature, T_J	150°C
Lead temperature 1,6 mm (1/16 inch) from case for 10 seconds	260°C
Storage temperature range, T_{stg}	-65°C to 150°C

† Stresses beyond those listed under “absolute maximum ratings” may cause permanent damage to the device. These are stress ratings only, and functional operation of the device at these or any other conditions beyond those indicated under “recommended operating conditions” is not implied. Exposure to absolute-maximum-rated conditions for extended periods may affect device reliability.

NOTES: 1. All voltage values are with respect to the anode terminal.

- Maximum power dissipation is a function of $T_J(\max)$, θ_{JA} , and T_A . The maximum allowable power dissipation at any allowable ambient temperature is $P_D = (T_J(\max) - T_A)/\theta_{JA}$. Operating at the absolute maximum T_J of 150°C can impact reliability.
- The package thermal impedance is calculated in accordance with JESD 51-7.

recommended operating conditions

		MIN	MAX	UNIT
V_Z	Regulator voltage	V_{ref}	30	V
I_Z	Regulator current	2	100	mA
T_A	Operating free-air temperature range	TL430C		°C

electrical characteristics over recommended operating conditions, $T_A = 25^\circ\text{C}$ (unless otherwise noted)

PARAMETER	TEST FIGURE	TEST CONDITIONS	TL430C			UNIT
			MIN	TYP	MAX	
$V_{I(ref)}$	1	$V_Z = V_{I(ref)}$, $I_Z = 10\text{ mA}$	2.5	2.75	3	V
$\alpha V_{I(ref)}$	1	$V_Z = V_{I(ref)}$, $I_Z = 10\text{ mA}$, $T_A = 0^\circ\text{C}$ to 70°C	120			ppm/°C
$I_{I(ref)}$	2	$I_Z = 10\text{ mA}$, $R_1 = 10\text{ k}\Omega$, $R_2 = \infty$	3 10			μA
I_{ZK}	1	$V_Z = V_{I(ref)}$	0.5 2			mA
I_{ZK}	1	$V_Z = V_{I(ref)}$	50			mA
	2	$V_Z = 5\text{ V}$ to 30 V , See Note 4	100			
r_z	1	$V_Z = V_{I(ref)}$, $\Delta I_Z = (52 - 2)\text{ mA}$	1.5 3			Ω
V_n	2	$f = 0.1\text{ Hz}$ to 10 Hz	$V_Z = 3\text{ V}$			μV
			$V_Z = 12\text{ V}$			
			$V_Z = 30\text{ V}$			

NOTES: 4. The average power dissipation, $V_Z \cdot I_Z \cdot \text{duty cycle}$, must not exceed the maximum continuous rating in any 10-ms interval.

5. The regulator resistance for $V_Z > V_{I(ref)}$, r_z , is given by:

$$r_z' = r_z \left(1 + \frac{R_1}{R_2} \right)$$



PARAMETER MEASUREMENT INFORMATION

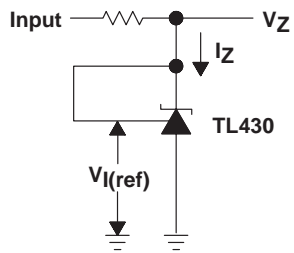
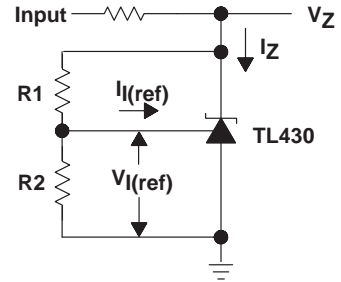

Figure 1. Test Circuit for $V_Z = V_{I(ref)}$



$$V_Z = V_{I(ref)} \left(1 + \frac{R1}{R2} \right) + I_{I(ref)} \times R1$$

Figure 2. Test Circuit for $V_Z > V_{I(ref)}$

TL430 ADJUSTABLE SHUNT REGULATORS

SLVS050D – JUNE 1976 – REVISED JANUARY 2005

TYPICAL CHARACTERISTICS

SMALL-SIGNAL REGULATOR IMPEDANCE
vs
FREQUENCY

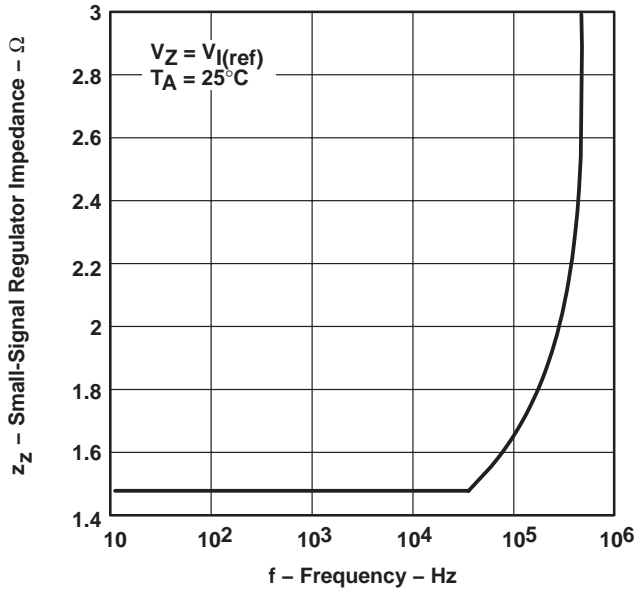

Figure 3

CATHODE CURRENT
vs
CATHODE VOLTAGE

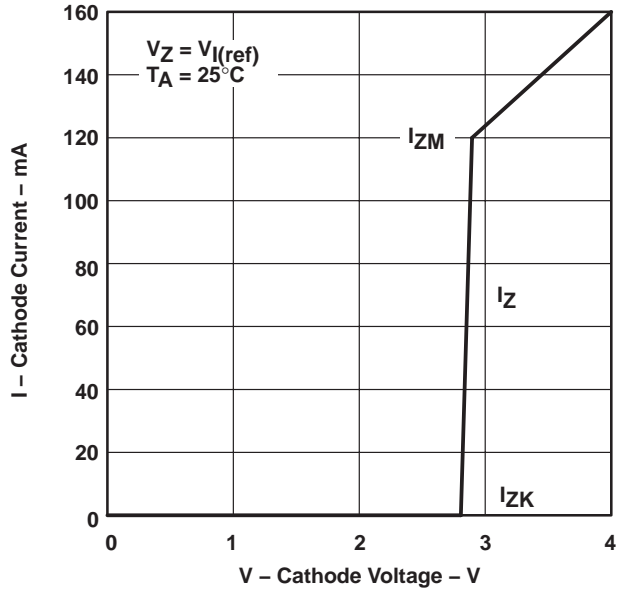
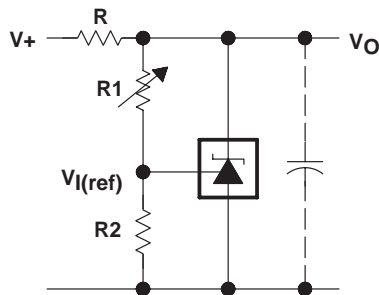

Figure 4

APPLICATION INFORMATION



$$V_O \approx \left(1 + \frac{R1}{R2}\right) V_{I(ref)}$$

Figure 5. Shunt Regulator

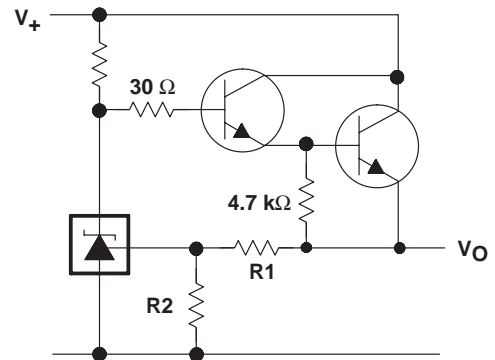

$$V_O \approx \left(1 + \frac{R1}{R2}\right) V_{I(ref)}$$

Figure 6. Series Regulator

APPLICATION INFORMATION

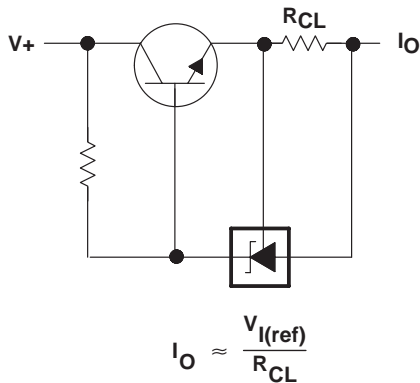
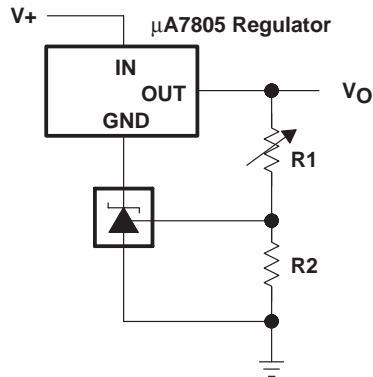

Figure 7. Current Limiter



$$V_O = \left(1 + \frac{R1}{R2}\right) V_{I(\text{ref})}$$

$$\text{Min } V_O = V_{I(\text{ref})} + 5V$$

Figure 8. Output Control of a 3-Terminal Fixed Regulator

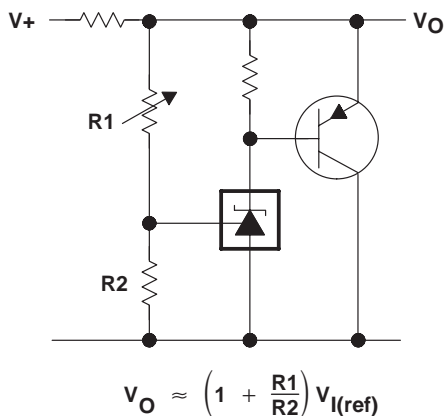

Figure 9. Higher-Current Applications

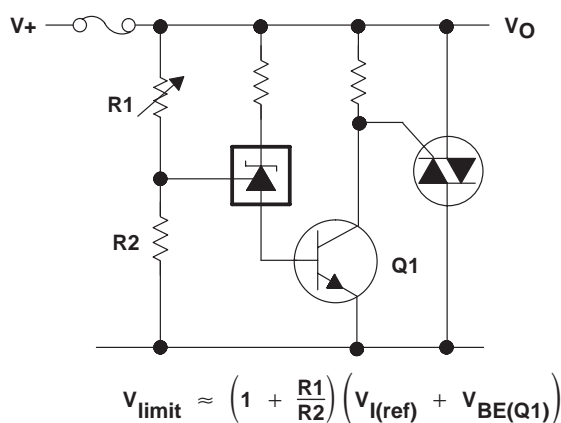

Figure 10. Crowbar

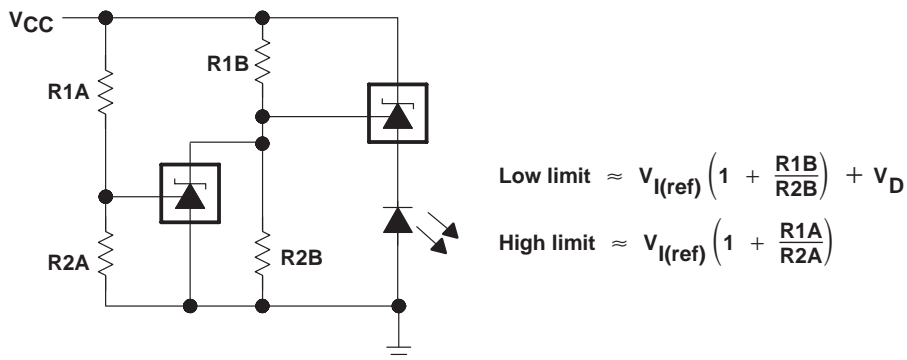

Figure 11. V_{CC} Monitor

PACKAGING INFORMATION

Orderable part number	Status (1)	Material type (2)	Package Pins	Package qty Carrier	RoHS (3)	Lead finish/ Ball material (4)	MSL rating/ Peak reflow (5)	Op temp (°C)	Part marking (6)
TL430CLP	Active	Production	TO-92 (LP) 3	1000 BULK	Yes	SN	N/A for Pkg Type	0 to 70	TL430C
TL430CLP.A	Active	Production	TO-92 (LP) 3	1000 BULK	Yes	SN	N/A for Pkg Type	0 to 70	TL430C

(1) **Status:** For more details on status, see our [product life cycle](#).

(2) **Material type:** When designated, preproduction parts are prototypes/experimental devices, and are not yet approved or released for full production. Testing and final process, including without limitation quality assurance, reliability performance testing, and/or process qualification, may not yet be complete, and this item is subject to further changes or possible discontinuation. If available for ordering, purchases will be subject to an additional waiver at checkout, and are intended for early internal evaluation purposes only. These items are sold without warranties of any kind.

(3) **RoHS values:** Yes, No, RoHS Exempt. See the [TI RoHS Statement](#) for additional information and value definition.

(4) **Lead finish/Ball material:** Parts may have multiple material finish options. Finish options are separated by a vertical ruled line. Lead finish/Ball material values may wrap to two lines if the finish value exceeds the maximum column width.

(5) **MSL rating/Peak reflow:** The moisture sensitivity level ratings and peak solder (reflow) temperatures. In the event that a part has multiple moisture sensitivity ratings, only the lowest level per JEDEC standards is shown. Refer to the shipping label for the actual reflow temperature that will be used to mount the part to the printed circuit board.

(6) **Part marking:** There may be an additional marking, which relates to the logo, the lot trace code information, or the environmental category of the part.

Multiple part markings will be inside parentheses. Only one part marking contained in parentheses and separated by a "~" will appear on a part. If a line is indented then it is a continuation of the previous line and the two combined represent the entire part marking for that device.

Important Information and Disclaimer:The information provided on this page represents TI's knowledge and belief as of the date that it is provided. TI bases its knowledge and belief on information provided by third parties, and makes no representation or warranty as to the accuracy of such information. Efforts are underway to better integrate information from third parties. TI has taken and continues to take reasonable steps to provide representative and accurate information but may not have conducted destructive testing or chemical analysis on incoming materials and chemicals. TI and TI suppliers consider certain information to be proprietary, and thus CAS numbers and other limited information may not be available for release.

In no event shall TI's liability arising out of such information exceed the total purchase price of the TI part(s) at issue in this document sold by TI to Customer on an annual basis.

LP0003A



PACKAGE OUTLINE

TO-92 - 5.34 mm max height

TO-92

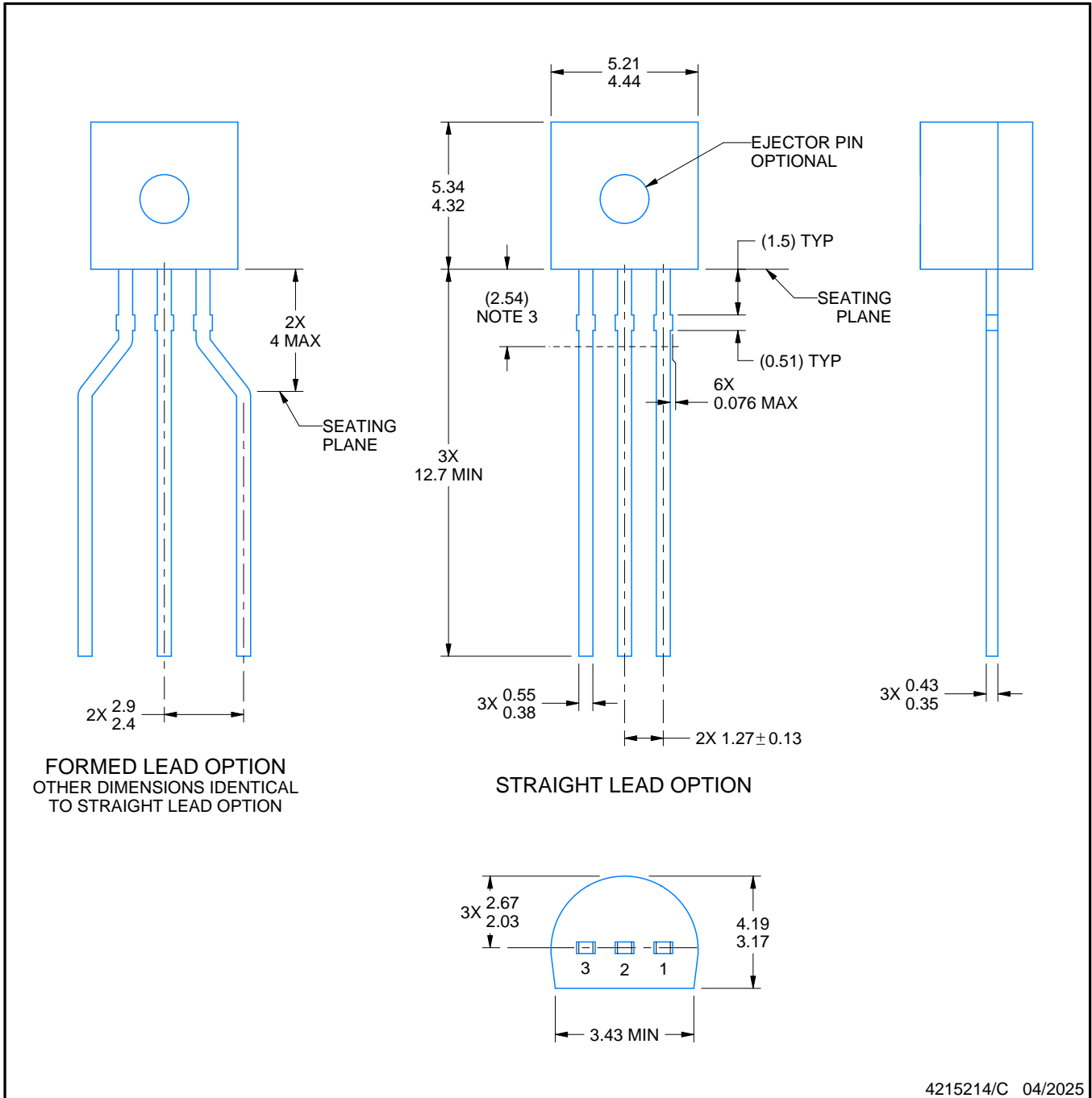

4215214/C 04/2025

NOTES:

1. All linear dimensions are in millimeters. Any dimensions in parenthesis are for reference only. Dimensioning and tolerancing per ASME Y14.5M.
2. This drawing is subject to change without notice.
3. Lead dimensions are not controlled within this area.
4. Reference JEDEC TO-226, variation AA.
5. Shipping method:
 - a. Straight lead option available in bulk pack only.
 - b. Formed lead option available in tape and reel or ammo pack.
 - c. Specific products can be offered in limited combinations of shipping medium and lead options.
 - d. Consult product folder for more information on available options.

EXAMPLE BOARD LAYOUT

LP0003A

TO-92 - 5.34 mm max height

TO-92

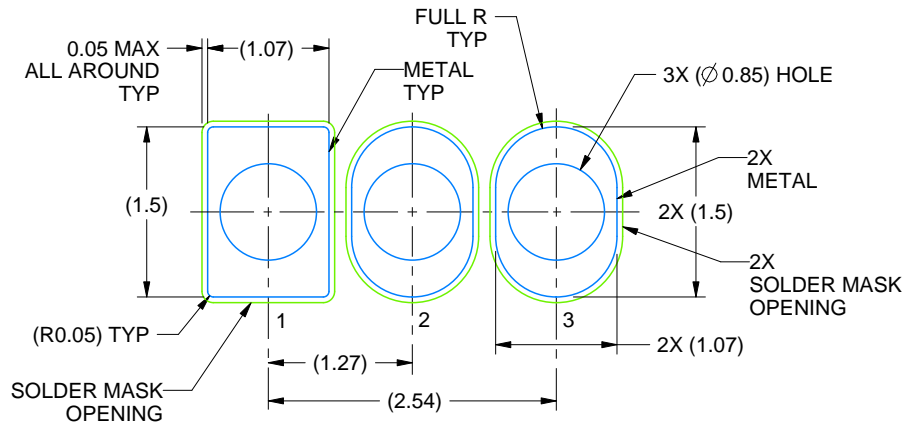

LAND PATTERN EXAMPLE
STRAIGHT LEAD OPTION
NON-SOLDER MASK DEFINED
SCALE:15X

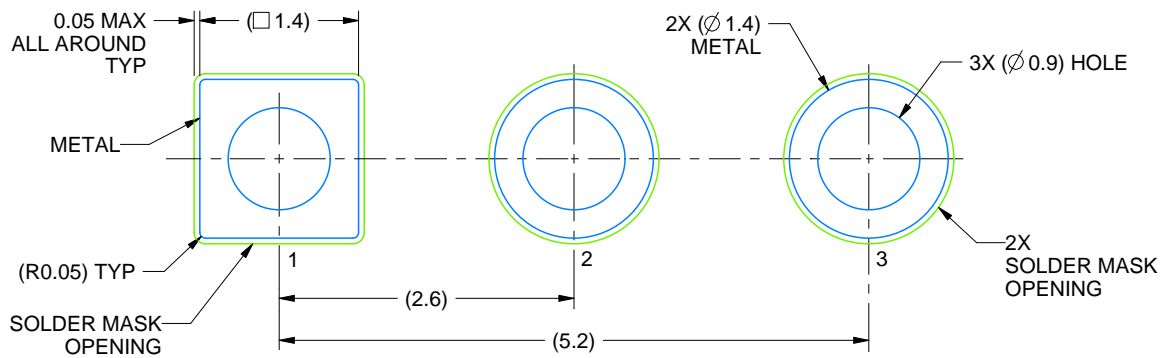

LAND PATTERN EXAMPLE
FORMED LEAD OPTION
NON-SOLDER MASK DEFINED
SCALE:15X

4215214/C 04/2025

TAPE SPECIFICATIONS

LP0003A

TO-92 - 5.34 mm max height

TO-92

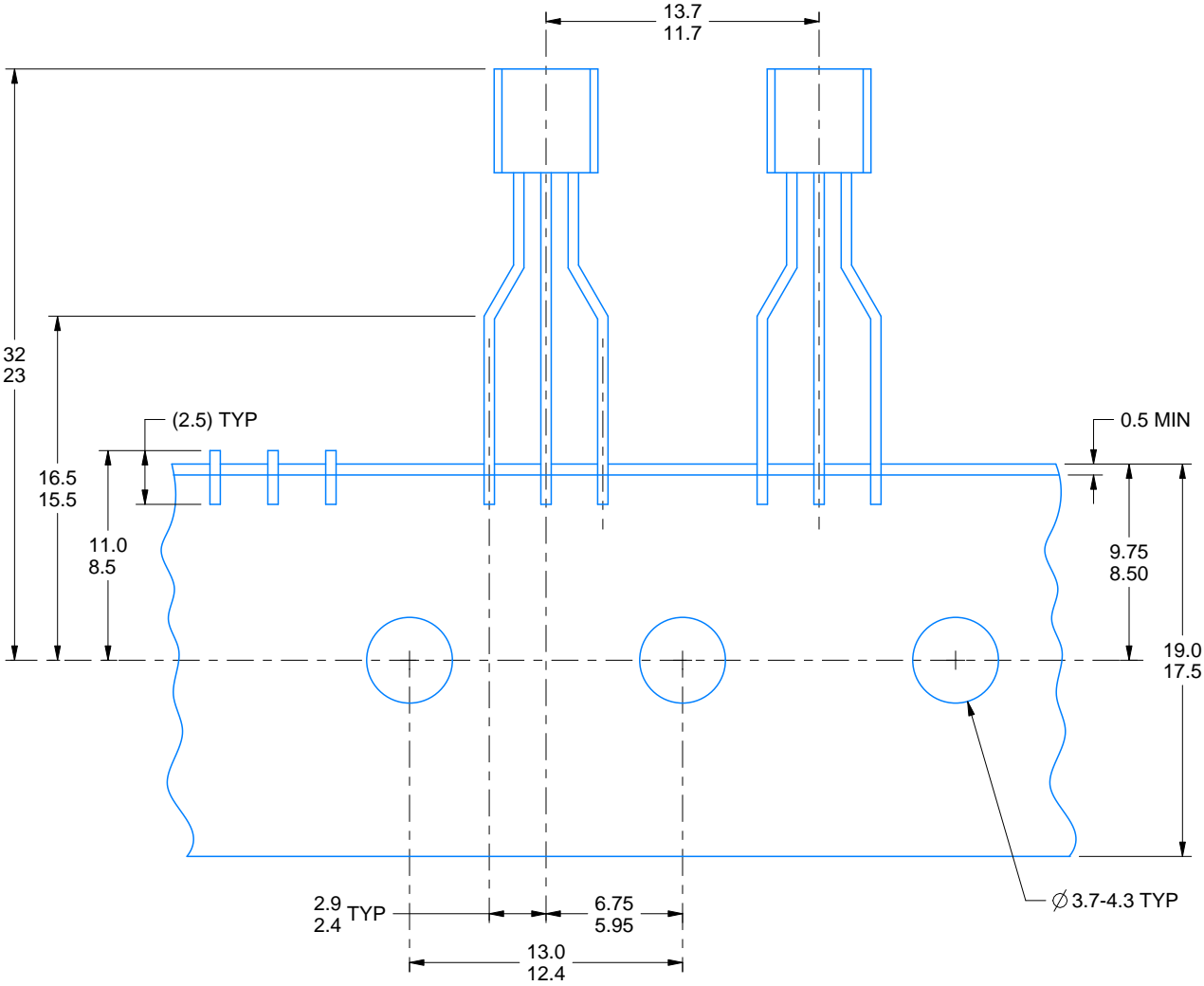

FOR FORMED LEAD OPTION PACKAGE

4215214/C 04/2025

IMPORTANT NOTICE AND DISCLAIMER

TI PROVIDES TECHNICAL AND RELIABILITY DATA (INCLUDING DATASHEETS), DESIGN RESOURCES (INCLUDING REFERENCE DESIGNS), APPLICATION OR OTHER DESIGN ADVICE, WEB TOOLS, SAFETY INFORMATION, AND OTHER RESOURCES "AS IS" AND WITH ALL FAULTS, AND DISCLAIMS ALL WARRANTIES, EXPRESS AND IMPLIED, INCLUDING WITHOUT LIMITATION ANY IMPLIED WARRANTIES OF MERCHANTABILITY, FITNESS FOR A PARTICULAR PURPOSE OR NON-INFRINGEMENT OF THIRD PARTY INTELLECTUAL PROPERTY RIGHTS.

These resources are intended for skilled developers designing with TI products. You are solely responsible for (1) selecting the appropriate TI products for your application, (2) designing, validating and testing your application, and (3) ensuring your application meets applicable standards, and any other safety, security, regulatory or other requirements.

These resources are subject to change without notice. TI grants you permission to use these resources only for development of an application that uses the TI products described in the resource. Other reproduction and display of these resources is prohibited. No license is granted to any other TI intellectual property right or to any third party intellectual property right. TI disclaims responsibility for, and you fully indemnify TI and its representatives against any claims, damages, costs, losses, and liabilities arising out of your use of these resources.

TI's products are provided subject to [TI's Terms of Sale](#), [TI's General Quality Guidelines](#), or other applicable terms available either on [ti.com](#) or provided in conjunction with such TI products. TI's provision of these resources does not expand or otherwise alter TI's applicable warranties or warranty disclaimers for TI products. Unless TI explicitly designates a product as custom or customer-specified, TI products are standard, catalog, general purpose devices.

TI objects to and rejects any additional or different terms you may propose.

Copyright © 2026, Texas Instruments Incorporated

Last updated 10/2025