

TLV840-Q1 Nano-Power Voltage Supervisor with Adjustable Reset Time Delay

1 Features

Qualified for automotive applications:

- AEC-Q100 qualified with the following results:
 - Device temperature grade 1: -40°C to $+125^{\circ}\text{C}$ ambient operating temperature
 - Device HBM ESD classification level 2
 - Device CDM ESD classification level C7B

Designed for high performance:

- Nano supply current : 120 nA (Typ)
- High accuracy: $\pm 0.5\%$ (Typ)
- Built-in hysteresis (V_{HYS}): 5% (Typ)
- Fixed threshold voltage ($V_{\text{IT-}}$): 0.8 V to 5.4 V

Designed for a wide range of applications:

- Operating voltage range : 0.7 V to 6 V
- Fixed ($V_{\text{IT-}}$) voltage: 0.8 V to 5.4 V in 0.1 V steps
- Programmable reset time delay (t_{D})
 - Min time delay: 40 μs (typ) without capacitor
- Active-low manual reset ($\overline{\text{MR}}$)

Multiple output topologies / Package type:

- Four output topologies ($\overline{\text{RESET}}$ / RESET):
 - TLV840MADL-Q1: open-drain, active-low
 - TLV840MAPL-Q1: push-pull, active-low
 - TLV840MADH-Q1: open-drain, active-high
 - TLV840MAPH-Q1: push-pull, active-high
- Package: SOT23-5 (DBV)

2 Applications

- [Surround view system, front camera](#)
- [Automotive gateway](#)
- [Radar ECU](#)
- [Automotive head unit](#)
- [ADAS controller](#)
- [Emergency call](#)
- [Telematics control unit](#)

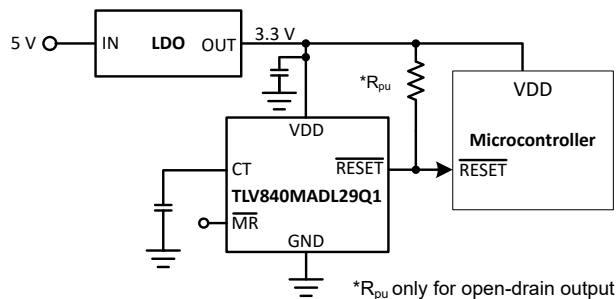

Typical Application Circuit

3 Description

The TLV840-Q1 device is a voltage supervisor or reset IC that can operate at wide input voltage levels from 0.7 V to 6 V while maintaining very low quiescent current across the whole VDD and temperature range. TLV840-Q1 offers the best combination of low power consumption, high accuracy and low propagation delay ($t_{\text{p_HL}} = 30 \mu\text{s}$ typical).

Reset output signal is asserted when the voltage at VDD drops below the negative voltage threshold ($V_{\text{IT-}}$). Reset signal is cleared when VDD rise above $V_{\text{IT-}}$ plus hysteresis (V_{HYS}) and the reset time delay (t_{D}) expires. Reset time delay can be programmed by connecting a capacitor between the CT pin and ground. For a minimum reset delay time the CT pin can be left floating. The TLV840-Q1, with its manual reset pin ($\overline{\text{MR}}$), offers program flexibility by forcing the system into a hard reset when the pin is asserted.

Additional features: Low power-on reset voltage (V_{POR}), built-in glitch immunity protection for VDD, built-in hysteresis, low open-drain output leakage current ($I_{\text{kg(OD)}}$). TLV840-Q1 is a perfect voltage monitoring solution for automotive applications and battery-powered / low-power applications.

Device Information

PART NUMBER	PACKAGE ⁽¹⁾	BODY SIZE (NOM)
TLV840-Q1	SOT-23 (5) (DBV)	2.90 mm × 1.60 mm

- (1) For package details, see the mechanical drawing addendum at the end of the data sheet.

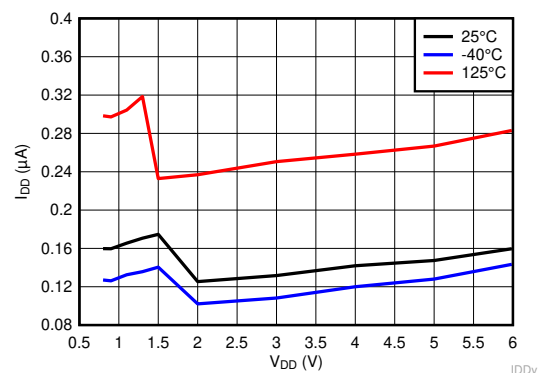

Typical Supply Current



Table of Contents

1 Features	1	8.2 Functional Block Diagram.....	12
2 Applications	1	8.3 Feature Description.....	12
3 Description	1	8.4 Device Functional Modes.....	17
4 Revision History	2	9 Application and Implementation	18
5 Device Comparison	3	9.1 Application Information.....	18
6 Pin Configuration and Functions	4	9.2 Typical Application.....	18
7 Specifications	5	10 Power Supply Recommendations	21
7.1 Absolute Maximum Ratings	5	11 Layout	22
7.2 ESD Ratings	5	11.1 Layout Guidelines.....	22
7.3 Recommended Operating Conditions	5	11.2 Layout Example.....	22
7.4 Thermal Information	5	12 Device and Documentation Support	23
7.5 Electrical Characteristics	6	12.1 Device Nomenclature.....	23
7.6 Timing Requirements	7	12.2 Receiving Notification of Documentation Updates..	24
7.7 Timing Diagrams	8	12.3 Support Resources.....	24
7.8 Typical Characteristics	10	12.4 Trademarks.....	24
8 Detailed Description	12	13 Mechanical, Packaging, and Orderable Information	24
8.1 Overview.....	12		

4 Revision History

Changes from Revision * (November 2020) to Revision A (April 2021)	Page
• RTM release.....	1

5 Device Comparison

Figure 5-1 shows the device naming nomenclature to compare the different device variants. See Section 12.1 for a more detailed explanation.

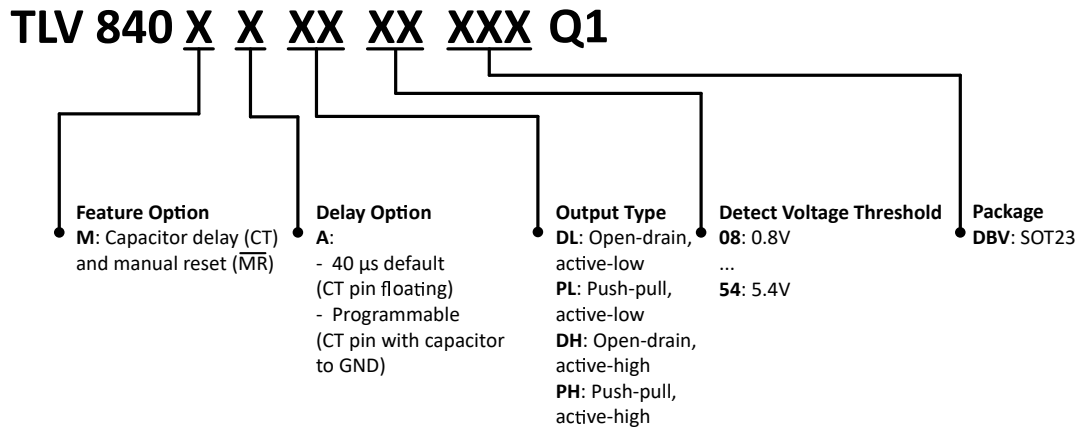
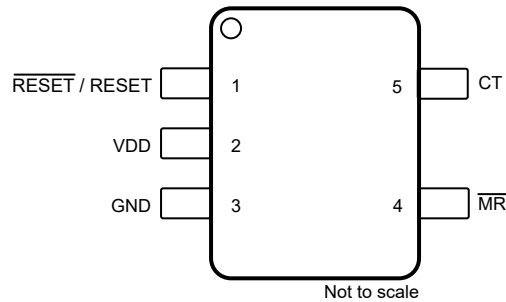

Figure 5-1. Device Naming Nomenclature

6 Pin Configuration and Functions



**Figure 6-1. Pin Configuration TLV840M-Q1
DBV Package 5-Pin SOT-23
TLV840M-Q1 Top View**

Table 6-1. Pin Functions

PIN NO.	PIN		I/O	DESCRIPTION
	TLV840MAxL-Q1	TLV840MAxH-Q1		
1	RESET	N/A	O	Active-Low Output Reset Signal: This pin is driven logic low when VDD voltage falls below the negative voltage threshold (V_{IT-}). RESET remains low (asserted) for the delay time period (t_D) after VDD voltage rises above $V_{IT+} = V_{IT-} + V_{HYS}$.
1	N/A	RESET	O	Active-High Output Reset Signal: This pin is driven logic high when VDD voltage falls below the negative voltage threshold (V_{IT-}). RESET remains high (asserted) for the delay time period (t_D) after VDD voltage rises above $V_{IT+} = V_{IT-} + V_{HYS}$.
2	VDD	VDD	I	Input Supply Voltage: TLV840-Q1 monitors VDD voltage
3	GND	GND	-	Ground
4	MR	MR	I	Manual Reset: Pull this pin to a logic low to assert a reset signal in the RESET output pin. After MR pin is left floating or pulls to logic high, the RESET output deasserts to the nominal state after the reset delay time (t_D) expires.
5	CT	CT	-	Capacitor Time Delay Pin: The CT pin offers a user-programmable delay time. Connect an external capacitor on this pin to adjust time delay. When not in use leave pin floating for the smallest fixed time delay.

7 Specifications

7.1 Absolute Maximum Ratings

over operating free-air temperature range, unless otherwise noted⁽¹⁾

		MIN	MAX	UNIT
Voltage	VDD	-0.3	6.5	V
Voltage	CT, $\overline{\text{MR}}$ ⁽²⁾ , $\overline{\text{RESET}}$ (TLV840MAPL), $\overline{\text{RESET}}$ (TLV840MAPH)	-0.3	$V_{\text{DD}}+0.3$ ⁽³⁾	V
	$\overline{\text{RESET}}$ (TLV840MADL)	-0.3	6.5	
Current	$\overline{\text{RESET}}$, RESET pin	-20	20	mA
Temperature ⁽⁴⁾	Operating ambient temperature, T_{A}	-40	125	°C
Temperature ⁽⁴⁾	Storage, T_{stg}	-65	150	

(1) Stresses beyond those listed under *Absolute Maximum Rating* may cause permanent damage to the device. These are stress ratings only, which do not imply functional operation of the device at these or any other conditions beyond those indicated under *Recommended Operating Condition*. Exposure to absolute-maximum-rated conditions for extended periods may affect device reliability.

(2) If the logic signal driving $\overline{\text{MR}}$ is less than VDD, then I_{DD} current increases based on voltage differential.

(3) The absolute maximum rating is (VDD + 0.3) V or 6.5 V, whichever is smaller

(4) As a result of the low dissipated power in this device, it is assumed that $T_{\text{J}} = T_{\text{A}}$.

7.2 ESD Ratings

			VALUE	UNIT
$V_{\text{(ESD)}}$	Electrostatic discharge	Human body model (HBM), per AEC Q100-002 ⁽¹⁾	±2000	V
		Charged device model (CDM), per AEC Q100-011	±750	

(1) AEC Q100-002 indicates that HBM stressing shall be in accordance with the ANSI/ESDA/JEDEC JS-001 specification.

7.3 Recommended Operating Conditions

over operating free-air temperature range (unless otherwise noted)

		MIN	NOM	MAX	UNIT
Voltage	VDD (TLV840MAXL)	0.7		6	V
	CT, $\overline{\text{RESET}}$ (TLV840MAXL), $\overline{\text{RESET}}$ (TLV840MAPH), $\overline{\text{MR}}$	0		6	
Current	$\overline{\text{RESET}}$ and RESET pin current	-5		5	mA
T_{A}	Operating ambient temperature	-40		125	°C

7.4 Thermal Information

THERMAL METRIC ⁽¹⁾		TLV840-Q1	UNIT
		DBV (SOT23-5)	
		5 PINS	
$R_{\theta\text{JA}}$	Junction-to-ambient thermal resistance	193.5	°C/W
$R_{\theta\text{JC(top)}}$	Junction-to-case (top) thermal resistance	117.9	°C/W
$R_{\theta\text{JB}}$	Junction-to-board thermal resistance	98.5	°C/W
Ψ_{JT}	Junction-to-top characterization parameter	43.4	°C/W
Ψ_{JB}	Junction-to-board characterization parameter	97.8	°C/W
$R_{\theta\text{JC(bot)}}$	Junction-to-case (bottom) thermal resistance	N/A	°C/W

(1) For more information about traditional and new thermal metrics, see the [Semiconductor and IC Package Thermal Metrics](#) application report.

7.5 Electrical Characteristics

At $0.7\text{ V} \leq V_{DD} \leq 6\text{ V}$, $CT = \overline{MR} = \text{Open}$, \overline{RESET} pull-up resistor ($R_{\text{pull-up}}$) = 100 k Ω to VDD, output reset load (C_{LOAD}) = 10 pF and over operating free-air temperature range -40°C to 125°C , unless otherwise noted. VDD ramp rate $\leq 100\text{ mV}/\mu\text{s}$. Typical values are at $T_A = 25^{\circ}\text{C}$

PARAMETER		TEST CONDITIONS	MIN	TYP	MAX	UNIT
COMMON PARAMETERS						
V_{DD}	Input supply voltage	TLV840MAXL	0.7		6	V
V_{IT-}	Negative-going input threshold accuracy (1)	$V_{IT-} = 0.8\text{ V to }1.7\text{ V}$	-2.5	± 0.5	2.5	%
		$V_{IT-} = 1.8\text{ V to }5.4\text{ V}$	-2	± 0.5	2	
V_{HYS}	Hysteresis on V_{IT-} pin		2.5	5	7	%
I_{DD}	Supply current into VDD pin (2)	$V_{DD} = 2\text{ V}; V_{IT-} = 0.8\text{ V to }1.8\text{ V}$		0.12	1.0	μA
		$V_{DD} = 6\text{ V}; V_{IT-} = 0.8\text{ V to }5.4\text{ V}$		0.15	1.2	
V_{MR_L}	Manual reset logic low input (2)				$0.3V_{DD}$	V
V_{MR_H}	Manual reset logic high input (2)		$0.7V_{DD}$			V
R_{MR}	Manual reset internal pull-up resistance			100		k Ω
R_{CT}	CT pin internal resistance			500		k Ω
TLV840MADL (Open-drain active-low)						
V_{POR}	Power on Reset Voltage (3)	$V_{OL(max)} = 300\text{ mV}$ $I_{OUT(Sink)} = 15\text{ }\mu\text{A}$			700	mV
V_{OL}	Low level output voltage	$V_{DD} = 0.7\text{ V}, 0.8\text{ V} \leq V_{IT-} \leq 1.5\text{ V}$ $I_{OUT(Sink)} = 15\text{ }\mu\text{A}$			300	mV
		$V_{DD} = 1.5\text{ V}, 1.6\text{ V} \leq V_{IT-} \leq 3.3\text{ V}$ $I_{OUT(Sink)} = 500\text{ }\mu\text{A}$			300	
		$V_{DD} = 3.3\text{ V}, 3.4\text{ V} \leq V_{IT-} \leq 5.5\text{ V}$ $I_{OUT(Sink)} = 2\text{ mA}$			300	
$I_{lkg(OD)}$	Open-Drain output leakage current	$V_{DD} = V_{PULLUP} = 6\text{ V}$ $T_A = -40^{\circ}\text{C to }85^{\circ}\text{C}$		10	100	nA
		$V_{DD} = V_{PULLUP} = 6\text{ V}$		10	350	nA
TLV840MAPL (Push-pull active-low)						
V_{POR}	Power on Reset Voltage (3)	$V_{OL(max)} = 300\text{ mV}$ $I_{OUT(Sink)} = 15\text{ }\mu\text{A}$			700	mV
V_{OL}	Low level output voltage	$V_{DD} = 0.7\text{ V}, 0.8\text{ V} \leq V_{IT-} \leq 1.5\text{ V}$ $I_{OUT(Sink)} = 15\text{ }\mu\text{A}$			300	mV
		$V_{DD} = 1.5\text{ V}, 1.6\text{ V} \leq V_{IT-} \leq 3.3\text{ V}$ $I_{OUT(Sink)} = 500\text{ }\mu\text{A}$			300	
		$V_{DD} = 3.3\text{ V}, 3.4\text{ V} \leq V_{IT-} \leq 5.5\text{ V}$ $I_{OUT(Sink)} = 2\text{ mA}$			300	
V_{OH}	High level output voltage	$V_{DD} = 1.8\text{ V}, 0.8\text{ V} \leq V_{IT-} \leq 1.4\text{ V}$ $I_{OUT(Source)} = 500\text{ }\mu\text{A}$	$0.8V_{DD}$			V
		$V_{DD} = 3.3\text{ V}, 1.5\text{ V} \leq V_{IT-} \leq 3.0\text{ V}$ $I_{OUT(Source)} = 500\text{ }\mu\text{A}$	$0.8V_{DD}$			
		$V_{DD} = 6\text{ V}, 3.1\text{ V} \leq V_{IT-} \leq 5.5\text{ V}$ $I_{OUT(Source)} = 2\text{ mA}$	$0.8V_{DD}$			

7.5 Electrical Characteristics (continued)

At $0.7\text{ V} \leq V_{DD} \leq 6\text{ V}$, $CT = \overline{MR} = \text{Open}$, \overline{RESET} pull-up resistor ($R_{\text{pull-up}}$) = 100 k Ω to VDD, output reset load (C_{LOAD}) = 10 pF and over operating free-air temperature range -40°C to 125°C , unless otherwise noted. VDD ramp rate $\leq 100\text{ mV}/\mu\text{s}$. Typical values are at $T_A = 25^{\circ}\text{C}$

PARAMETER		TEST CONDITIONS	MIN	TYP	MAX	UNIT
TLV840MAPH (Push-pull active-high)						
V_{POR}	Power on Reset Voltage ⁽³⁾	$V_{\text{OH(min)}} = 0.8V_{\text{DD}}$ $I_{\text{OUT(SOURCE)}} = 15\text{ }\mu\text{A}$			900	mV
V_{OL}	Low level output voltage	VDD=3.3 V $0.8\text{ V} \leq V_{\text{IT-}} \leq 3.0\text{ V}$ $I_{\text{OUT(SINK)}} = 500\text{ }\mu\text{A}$			300	mV
		VDD=6 V $3.1\text{ V} \leq V_{\text{IT-}} \leq 5.5\text{ V}$ $I_{\text{OUT(SINK)}} = 2\text{ mA}$			300	mV
V_{OH}	High level output voltage	VDD = 0.9 V $1\text{ V} \leq V_{\text{IT-}} \leq 1.5\text{ V}$ $I_{\text{OUT(SINK)}} = 15\text{ }\mu\text{A}$	0.8V _{DD}			V
		VDD=1.5 V $1.6\text{ V} \leq V_{\text{IT-}} \leq 3.3\text{ V}$ $I_{\text{OUT(SINK)}} = 500\text{ }\mu\text{A}$	0.8V _{DD}			V
		VDD=3.3 V $3.4\text{ V} \leq V_{\text{IT-}} \leq 5.5\text{ V}$ $I_{\text{OUT(SINK)}} = 2\text{ mA}$	0.8V _{DD}			V

- $V_{\text{IT-}}$ threshold voltage range from 0.8 V to 5.4 V (for DL, PL versions) in 100 mV steps
- If the logic signal driving \overline{MR} is less than VDD, then I_{DD} current increases based on voltage differential
- V_{POR} is the minimum V_{DD} voltage level for a controlled output state

7.6 Timing Requirements

At $0.7\text{ V} \leq V_{DD} \leq 6\text{ V}$, $CT = \overline{MR} = \text{Open}$, \overline{RESET} pull-up resistor ($R_{\text{pull-up}}$) = 100 k Ω to VDD, output reset load (C_{LOAD}) = 10 pF and over operating free-air temperature range -40°C to 125°C , unless otherwise noted. VDD ramp rate $\leq 100\text{ mV}/\mu\text{s}$. Typical values are at $T_A = 25^{\circ}\text{C}$

PARAMETER		TEST CONDITIONS	MIN	TYP	MAX	UNIT
$t_{\text{P_HL}}$	Propagation detect delay for VDD falling below $V_{\text{IT-}}$	$V_{\text{DD}} : (V_{\text{IT+}} + 10\%) \text{ to } (V_{\text{IT-}} - 10\%)$ ⁽¹⁾		30	50	μs
t_{D}	Reset time delay	CT pin = Open or NC ($V_{\text{IT-}} - 10\%$) to ($V_{\text{IT+}} + 10\%$)		40	80	μs
		CT pin = 10 nF		6.2		ms
		CT pin = 1 μF		619		ms
$t_{\text{GI_VIT-}}$	Glitch immunity $V_{\text{IT-}}$	5% $V_{\text{IT-}}$ overdrive ⁽²⁾		10		μs
t_{STRT}	Startup Delay ⁽³⁾	CT pin = Open or NC			300	μs
$t_{\text{MR_PW}}$	\overline{MR} pin pulse duration to assert reset ⁽⁴⁾			500		ns
$t_{\text{MR_RES}}$	Propagation delay from \overline{MR} low to reset assertion	$V_{\text{DD}} = 3.3\text{ V}$, $\overline{MR} = V_{\text{MR_H}}$ to $V_{\text{MR_L}}$		1		μs
$t_{\text{MR_TD}}$	Delay from \overline{MR} release to reset deassert	$V_{\text{DD}} = 3.3\text{ V}$, $\overline{MR} = V_{\text{MR_L}}$ to $V_{\text{MR_H}}$		t_{D}		ms

- $t_{\text{P_HL}}$ measured from threshold trip point ($V_{\text{IT-}}$) to \overline{RESET} assert. $V_{\text{IT+}} = V_{\text{IT-}} + V_{\text{HYS}}$
- Overdrive % = $[(V_{\text{DD}}/V_{\text{IT-}}) - 1] \times 100\%$
- When VDD starts from less than the specified minimum V_{DD} and then exceeds $V_{\text{IT-}}$, reset is release after the startup delay (t_{STRT}), a capacitor at CT pin will add t_{D} delay to t_{STRT} time
- Refer section on [Manual Reset Input](#) for min pulse width needed on \overline{MR} pin

7.7 Timing Diagrams

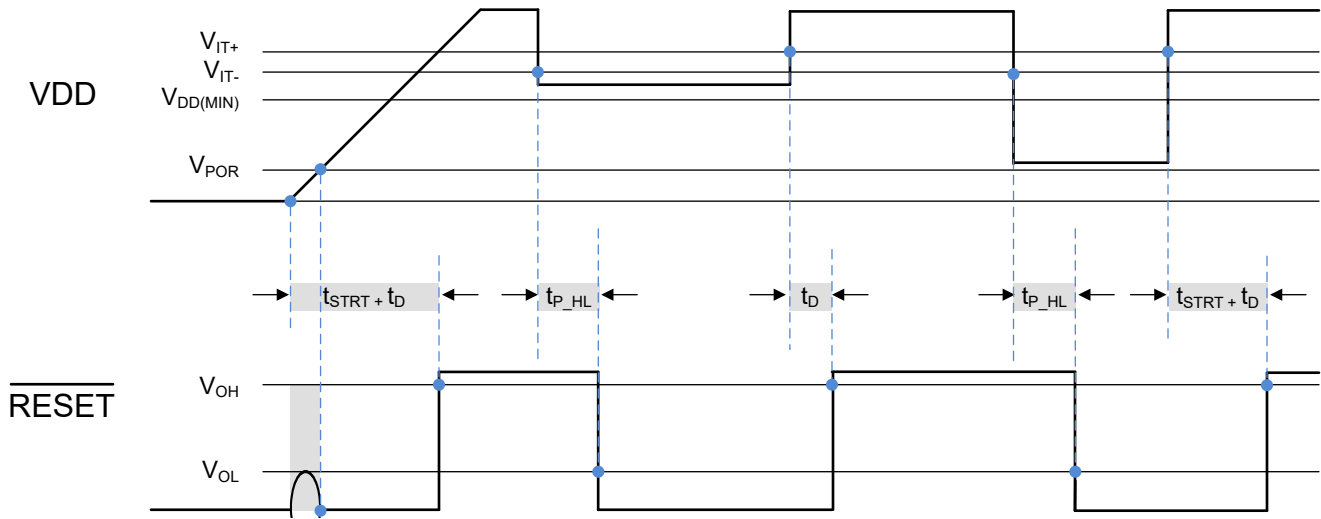

(1) $t_{D (no\ cap)}$ is included in t_{STRT} time delay. If t_D delay is programmed by an external capacitor connected to CT pin then t_D programmed time will be added to the startup time, V_{DD} slew rate = 100 mV / μ s.

(2) Open-Drain timing diagram where \overline{RESET} is pulled up to VDD via an external pull-up resistor

(3) \overline{RESET} output is undefined when V_{DD} is < V_{POR}

Figure 7-1. Timing Diagram TLV840MADL-Q1 (Open-Drain Active-Low)

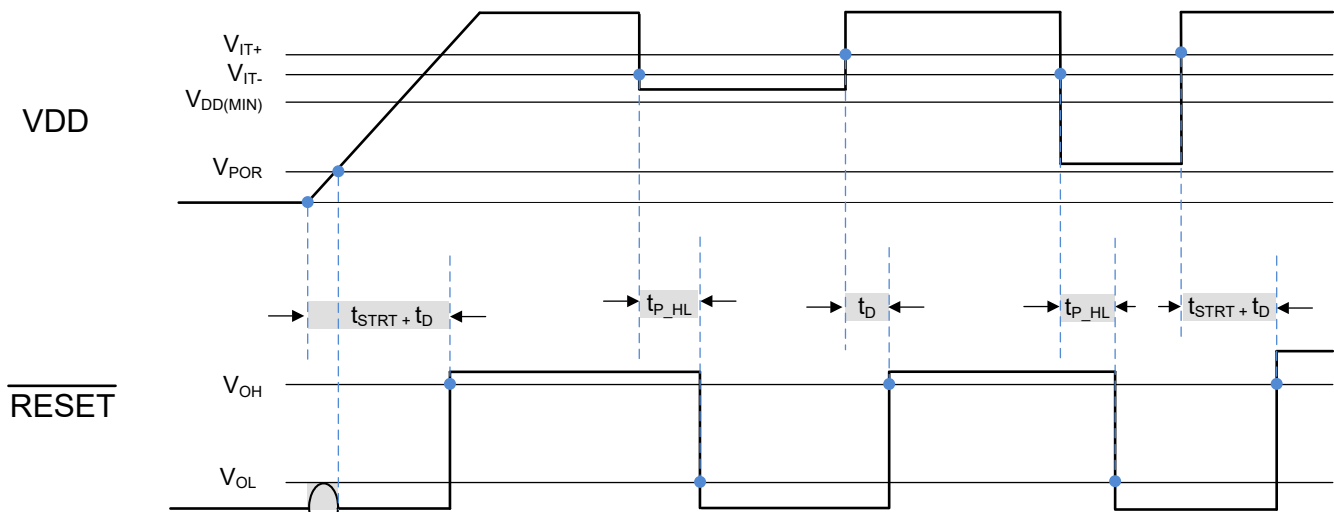

(4) $t_{D (no\ cap)}$ is included in t_{STRT} time delay. If t_D delay is programmed by an external capacitor connected to CT pin then t_D programmed time will be added to the startup time, V_{DD} slew rate = 100 mV / μ s.

(5) \overline{RESET} output is undefined when V_{DD} is < V_{POR} and limited to V_{OL} for V_{DD} slew rate = 100 mV / μ S

Figure 7-2. Timing Diagram TLV840MAPL-Q1 (Push-Pull Active-Low)

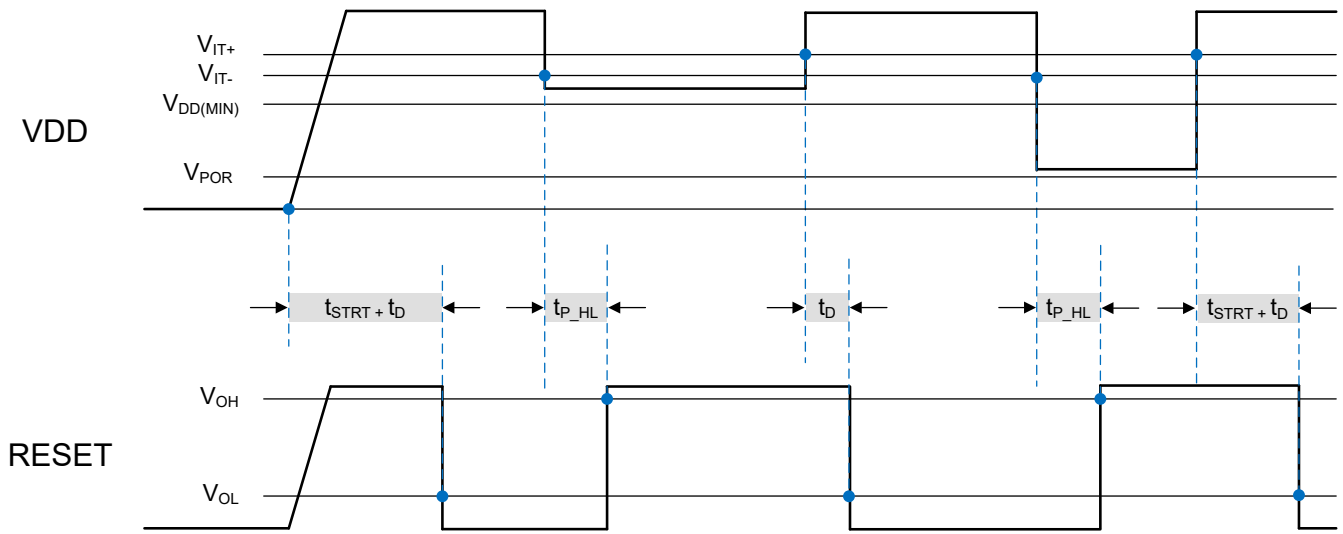

(6) $t_{D (no\ cap)}$ is included in t_{STRT} time delay. If t_D delay is programmed by an external capacitor connected to CT pin then t_D programmed time will be added to the startup time, VDD slew rate = 100 mV / μ s.

Figure 7-3. Timing Diagram TLV840MAPH-Q1 (Push-Pull Active-High)

7.8 Typical Characteristics

Typical characteristics show the typical performance of the TLV840-Q1 device. Test conditions are $T_A = 25^\circ\text{C}$, $V_{DD} = 3.3\text{ V}$, $R_{\text{Pull-Up}} = 100\text{ k}\Omega$, $C_{\text{LOAD}} = 50\text{ pF}$, unless otherwise noted.

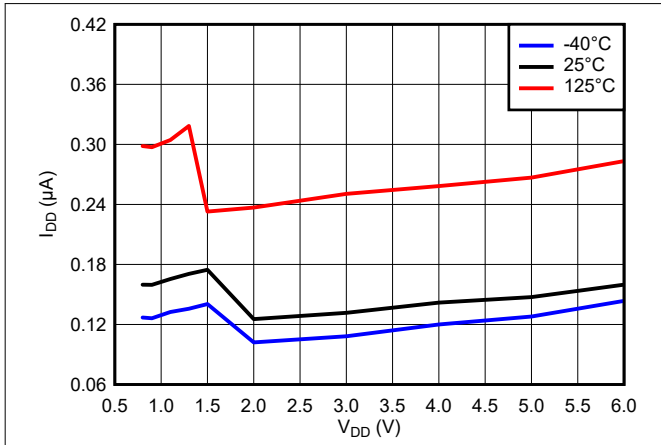

Figure 7-4. Supply Current vs Supply Voltage

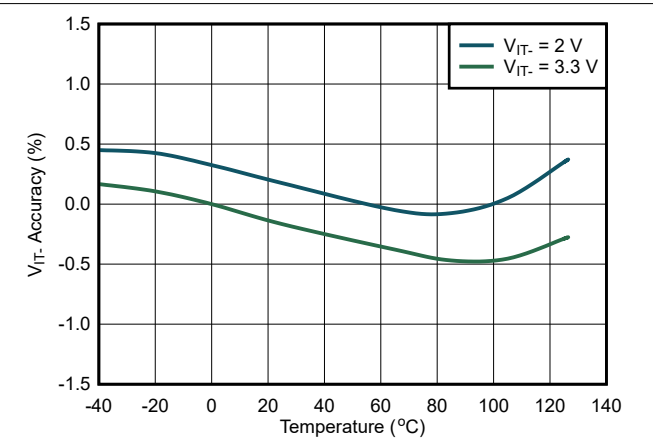

Figure 7-5. V_{IT-} Accuracy vs Temperature

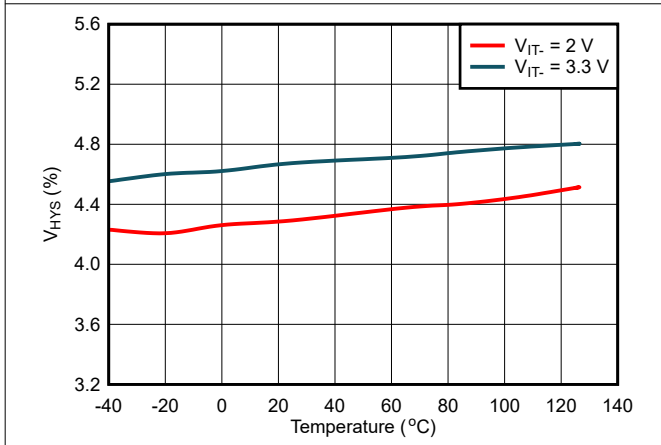

Figure 7-6. V_{HYS} vs Temperature

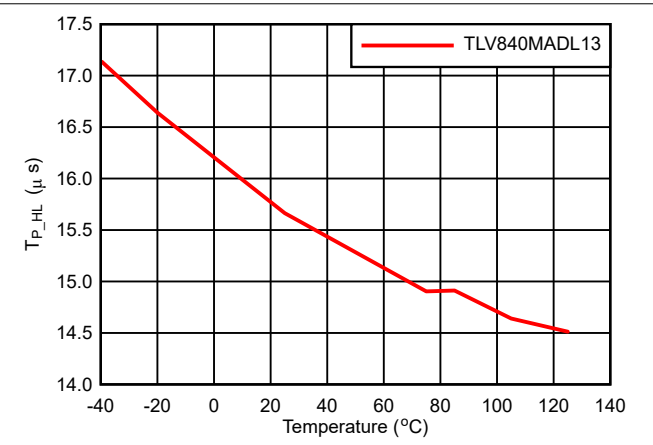

Figure 7-7. Propagation Delay vs Temperature

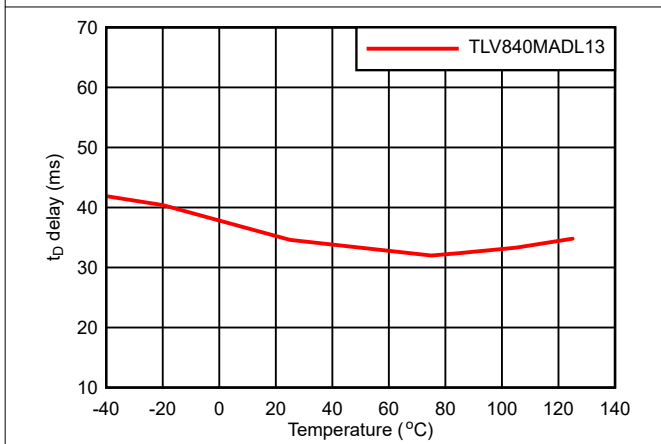

Figure 7-8. Reset Time Delay vs Temperature

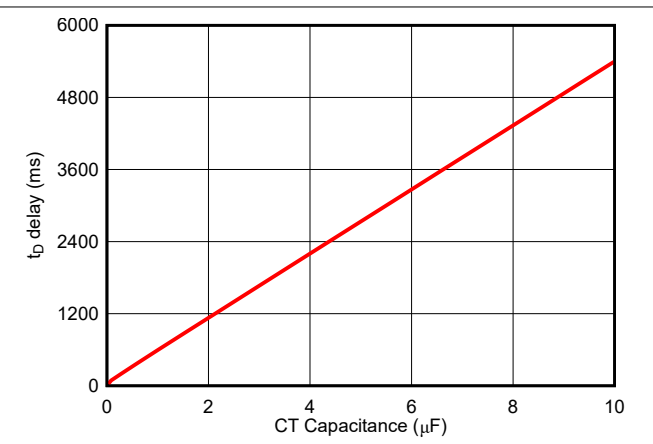
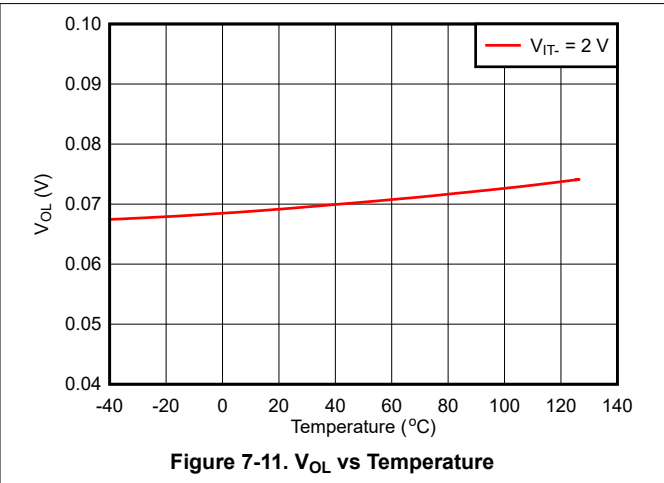
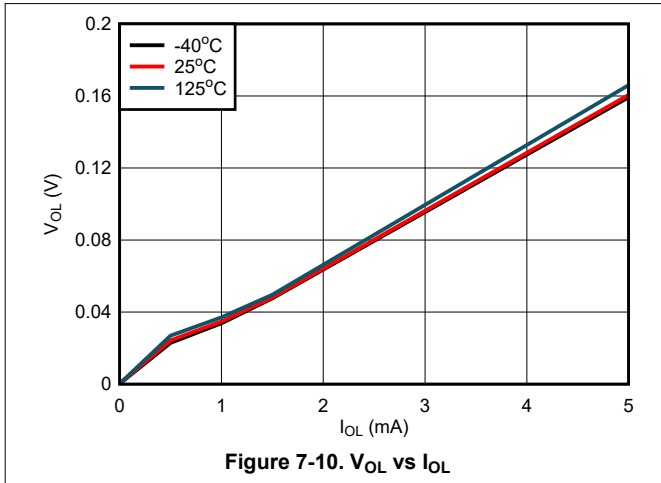

Figure 7-9. Reset Time Delay vs C_T Capacitance

7.8 Typical Characteristics (continued)

Typical characteristics show the typical performance of the TLV840-Q1 device. Test conditions are $T_A = 25^\circ\text{C}$, $V_{DD} = 3.3\text{ V}$, $R_{\text{Pull-Up}} = 100\text{ k}\Omega$, $C_{\text{LOAD}} = 50\text{ pF}$, unless otherwise noted.



8 Detailed Description

8.1 Overview

The TLV840-Q1 is a family of nano-quiescent current voltage detectors with fixed threshold voltage. TLV840-Q1 features include programmable reset time delay using external capacitor, active-low manual reset, 0.5% typical monitor threshold accuracy with hysteresis and glitch immunity.

Fixed negative threshold voltages (V_{IT-}) can be factory set from 0.8 V to 5.4 V. TLV840-Q1 is available in SOT-23 5-pin industry standard package.

8.2 Functional Block Diagram

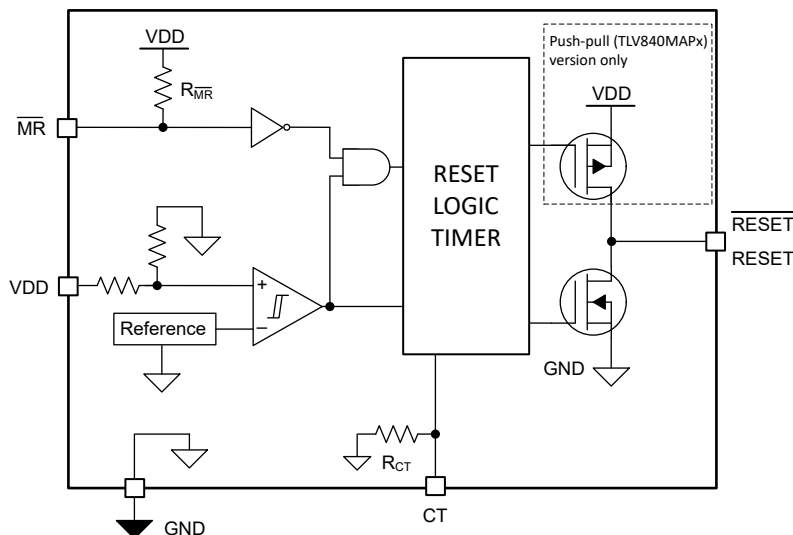

8.3 Feature Description

8.3.1 Input Voltage (VDD)

VDD pin is monitored by the internal comparator to indicate when VDD falls below the fixed threshold voltage. VDD also functions as the supply for the internal bandgap, internal regulator, state machine, buffers and other control logic blocks. Good design practice involve placing a 0.1 μF to 1 μF bypass capacitor at VDD input for noisy applications to ensure enough charge is available for the device to power up correctly.

8.3.1.1 VDD Hysteresis

The internal comparator has built-in hysteresis to avoid erroneous output reset release. If the voltage at the VDD pin falls below V_{IT-} , the output reset is asserted. When the voltage at the VDD pin goes above V_{IT-} plus hysteresis (V_{HYS}) the output reset is deasserted after t_D delay.

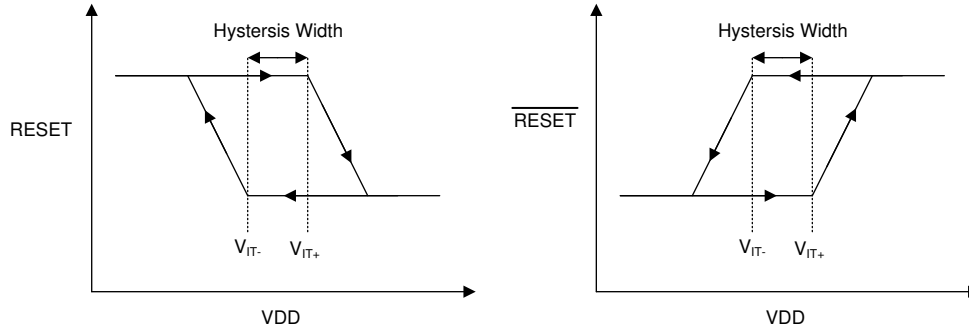

Figure 8-1. Hysteresis Diagram

8.3.1.2 VDD Transient Immunity

The TLV840-Q1 is immune to quick voltage transients or excursion on VDD. Sensitivity to transients depends on both pulse duration (t_{GI_VIT-}) found in Section 7.6 and overdrive. Overdrive is defined by how much VDD deviates from the specified threshold. Threshold overdrive is calculated as a percent of the threshold in question, as shown in Equation 1.

$$\text{Overdrive} = | [(V_{DD} / V_{IT-}) - 1] \times 100\% | \quad (1)$$

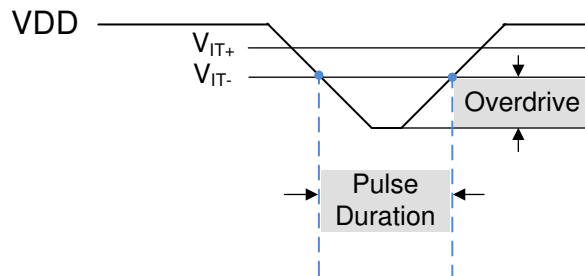

Figure 8-2. Overdrive vs Pulse Duration

8.3.2 User-Programmable Reset Time Delay

The reset time delay can be set to a minimum value of 80 μs by leaving the CT pin floating, or a maximum value of approximately 6.2 seconds by connecting 10 μF delay capacitor. The reset time delay (t_D) can be programmed by connecting a capacitor no larger than 10 μF between CT pin and GND.

The relationship between external capacitor (C_{CT}) in μF at CT pin and the time delay (t_D) in seconds is given by Equation 2.

$$t_{D(\text{typ})} = -\ln(0.29) \times R_{CT} \times C_{CT} + t_{D(\text{no cap})} \quad (2)$$

Equation 3 solves for external capacitor (μF) by plugging R_{CT} and t_D (CT pin = Open) given in Section 7.5 section:

$$C_{CT} = (t_D - 80 \mu\text{s}) \div 618937 \quad (3)$$

The reset delay varies according to three variables: the external capacitor (C_{CT}), CT pin internal resistance (R_{CT}) provided in Section 7.5, and a constant. The minimum and maximum variance due to the constant is shown in Equation 4 and Equation 5:

$$t_{D(\text{min})} = -\ln(0.37) \times R_{CT(\text{min})} \times C_{CT_EXT(\text{min})} + t_{D(\text{no cap})} \quad (4)$$

$$t_{D(\text{max})} = -\ln(0.25) \times R_{CT(\text{max})} \times C_{CT_EXT(\text{max})} + t_{D(\text{no cap})} \quad (5)$$

The recommended maximum delay capacitor for the TLV840-Q1 is limited to 10 μF as this ensures there is enough time for the capacitor to fully discharge when the reset condition occurs. When a voltage fault occurs, the previously charged up capacitor discharges, and if the monitored voltage returns from the fault condition before the delay capacitor discharges completely, the reset delay will be shorter than expected because the delay capacitor will begin charging from a voltage above zero. Larger delay capacitors can be used so long as the capacitor has enough time to fully discharge during the duration of the voltage fault. The amount of time required to discharge the delay capacitor relative to the reset delay increases as VDD overdrive increases as shown in Figure 8-3. From the graph below, to ensure the CT capacitor is fully discharged, the time period or duration of the voltage fault needs to be greater than 10% of the programmed reset time delay.

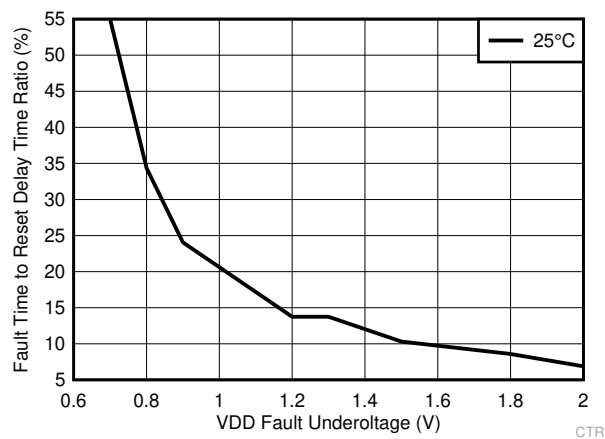

Figure 8-3. C_{CT} Discharge Time During Fault Condition ($V_{IT} = 2 \text{ V}$, $C_{CT} = 1 \mu\text{F}$)

8.3.3 Manual Reset ($\overline{\text{MR}}$) Input

The manual reset ($\overline{\text{MR}}$) input allows a processor GPIO or other logic circuits to initiate a reset. A logic low on $\overline{\text{MR}}$ with pulse duration longer than $t_{\overline{\text{MR_PW}}}$ will cause the reset output to assert. After $\overline{\text{MR}}$ returns to a logic high ($V_{\overline{\text{MR_H}}}$) and VDD is above $V_{\text{IT+}}$, reset is deasserted after the user programmed reset time delay (t_{D}) expires.

The minimum duration for which $\overline{\text{MR}}$ is held under $V_{\overline{\text{MR_L}}}$ must be at least 1% of $t_{\overline{\text{MR_ID}}}$. Otherwise, the effective reset delay will be shorter roughly by the difference between 1% of $t_{\overline{\text{MR_ID}}}$ and the actual $\overline{\text{MR}}$ pulse width. For large capacitor based delays this difference could be noticeable unless care is taken to lengthen the $\overline{\text{MR}}$ pulse width.

$\overline{\text{MR}}$ is internally connected to VDD through a pull-up resistor $R_{\overline{\text{MR}}}$ shown in Section 8.2. If the logic signal controlling $\overline{\text{MR}}$ is less than VDD, then additional current flows from VDD into $\overline{\text{MR}}$ internally. For minimum current consumption, drive $\overline{\text{MR}}$ to either VDD or GND. $V_{\overline{\text{MR}}}$ should not be higher than VDD voltage.

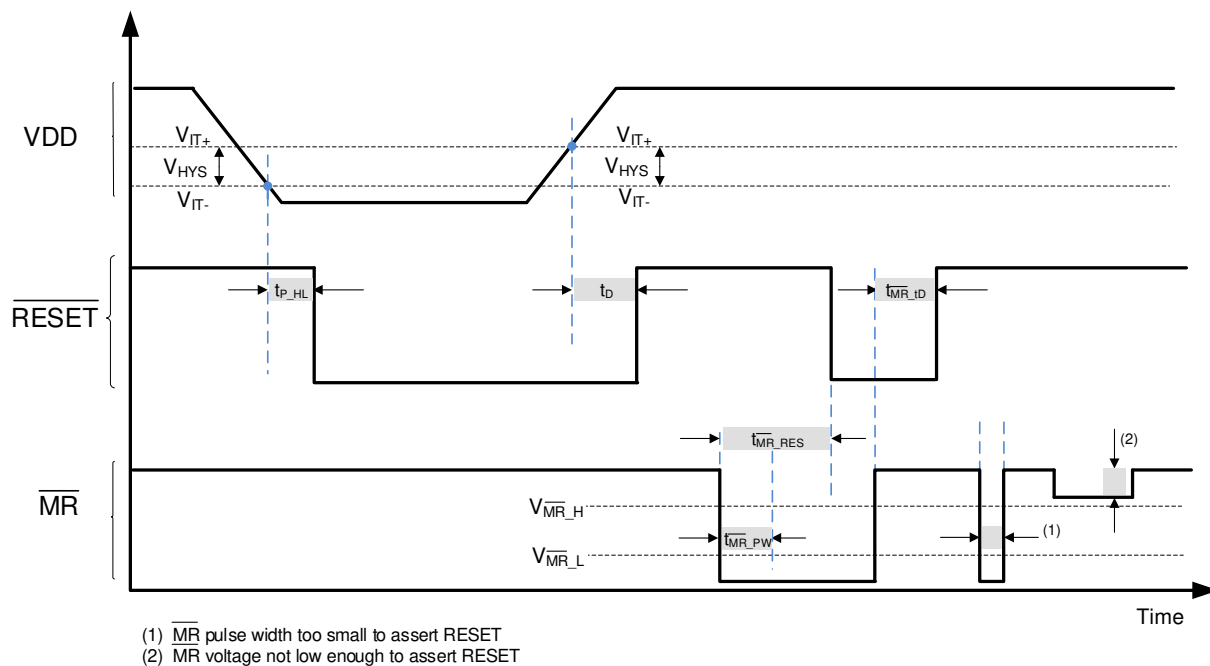

Figure 8-4. Timing Diagram $\overline{\text{MR}}$ and $\overline{\text{RESET}}$

8.3.4 Output Logic

8.3.4.1 RESE \overline{T} Output, Active-Low

RESE \overline{T} (Active-Low) applies to TLV840DL-Q1 (Open-Drain) and TLV840PL-Q1 (Push-Pull) hence the "L" in the device name. RESE \overline{T} remains high (deasserted) as long as VDD is above the negative threshold (V_{IT-}) and the MR pin is floating or above V_{MR_H} . If VDD falls below the negative threshold (V_{IT-}) or if MR is driven low, then RESE \overline{T} is asserted.

When MR is again logic high or floating and VDD rise above V_{IT+} , the delay circuit will hold RESE \overline{T} low for the specified reset time delay (t_D). When the reset time delay has elapsed, the RESE \overline{T} pin goes back to logic high voltage (V_{OH}).

The TLV840DL-Q1 (Open-Drain) version, denoted with "D" in the device name, requires an external pull-up resistor to hold RESE \overline{T} pin high. Connect the external pull-up resistor to the desired pull-up voltage source and RESE \overline{T} can be pulled up to any voltage up to 6.5 V independent of the VDD voltage. To ensure proper voltage levels, give some consideration when choosing the pull-up resistor values. The external pull-up resistor value determines the actual V_{OL} , the output capacitive loading, and the output leakage current ($I_{lk(OD)}$).

The Push-Pull variants (TLV840PL-Q1 and TLV840PH-Q1), denoted with "P" in the device name, does not require an external pull-up resistor.

8.3.4.2 RESE \overline{T} Output, Active-High

RESE \overline{T} (Active-High), denoted with no bar above the pin label, applies to TLV840DH-Q1 (Open-Drain) and TLV840PH-Q1 push-pull active-high version, hence the "H" in the device name. RESE \overline{T} remains low (deasserted) as long as VDD is above the negative threshold (V_{IT-}) and the MR pin is floating or above V_{MR_H} . If VDD falls below the negative threshold (V_{IT-}) or if MR is driven low, then RESE \overline{T} is asserted driving the RESE \overline{T} pin to high voltage (V_{OH}).

When MR is again logic high or floating and VDD rise above V_{IT+} the delay circuit will hold RESE \overline{T} high for the specified reset time delay (t_D). When the reset time delay has elapsed, the RESE \overline{T} pin goes back to logic low voltage (V_{OL}).

The TLV840DH-Q1 (Open-Drain) version, denoted with "D" in the device name, requires an external pull-up resistor to hold RESE \overline{T} pin high. Connect the external pull-up resistor to the desired pull-up voltage source and RESE \overline{T} can be pulled up to any voltage up to 6.5 V independent of the VDD voltage. To ensure proper voltage levels, give some consideration when choosing the pull-up resistor values. The external pull-up resistor value determines the actual V_{OL} , the output capacitive loading, and the output leakage current ($I_{lk(OD)}$).

The Push-Pull variants (TLV840PL-Q1 and TLV840PH-Q1), denoted with "P" in the device name, does not require an external pull-up resistor.

8.4 Device Functional Modes

Table 8-1 summarizes the various functional modes of the device. Logic high is represented by "H" and logic low is represented by "L".

Table 8-1. Truth Table

VDD	MR	RESET	RESET
$V_{DD} < V_{POR}$	Ignored	Undefined	Undefined
$V_{POR} < V_{DD} < V_{IT-}$	Ignored	H	L
$V_{DD} \geq V_{IT-}$	L	H	L
$V_{DD} \geq V_{IT-}$	H	L	H
$V_{DD} \geq V_{IT-}$	Floating	L	H

8.4.1 Normal Operation ($V_{DD} > V_{POR}$)

When VDD is greater than V_{POR} , the reset signal is determined by the voltage on the VDD pin with respect to the trip point (V_{IT-}).

- \overline{MR} high: the reset signal corresponds to VDD with respect to the threshold voltage.
- \overline{MR} low: in this mode, the reset is asserted regardless of the threshold voltage.

8.4.2 Below Power-On-Reset ($V_{DD} < V_{POR}$)

When the voltage on VDD is lower than V_{POR} , the device does not have enough bias voltage to internally pull the asserted output low or high and reset voltage level is undefined.

9 Application and Implementation

Note

Information in the following applications sections is not part of the TI component specification, and TI does not warrant its accuracy or completeness. TI's customers are responsible for determining suitability of components for their purposes. Customers should validate and test their design implementation to confirm system functionality.

9.1 Application Information

The following sections describe in detail how to properly use this device, depending on the requirements of the final application.

9.2 Typical Application

9.2.1 Design 1: Dual Rail Monitoring with Power-up Sequencing

A typical application for the TLV840-Q1 is voltage rail monitoring and power-up sequencing as shown in Figure 9-1. The TLV840-Q1 can be used to monitor any rail above 0.9 V. In this design application, two TLV840-Q1 devices monitor two separate voltage rails and sequences the rails upon power-up. The TLV840MAPL29-Q1 is used to monitor the 3.3-V main power rail and the TLV840MADL10-Q1 is used to monitor the 1.2-V rail provided by the LDO for other system peripherals. The $\overline{\text{RESET}}$ output of the TLV840MAPL29-Q1 is connected to the enable (EN) input of the LDO. A reset event is initiated on either voltage supervisor when the VDD voltage is less than V_{IT} . For a system-wide reset event, both $\overline{\text{MR}}$ pins are tied to the $\overline{\text{SYS_RST}}$. For the purpose of this application, the design detail on $\overline{\text{MR}}$ are not covered. For more information on the function of $\overline{\text{MR}}$, please see Section 8.3.3

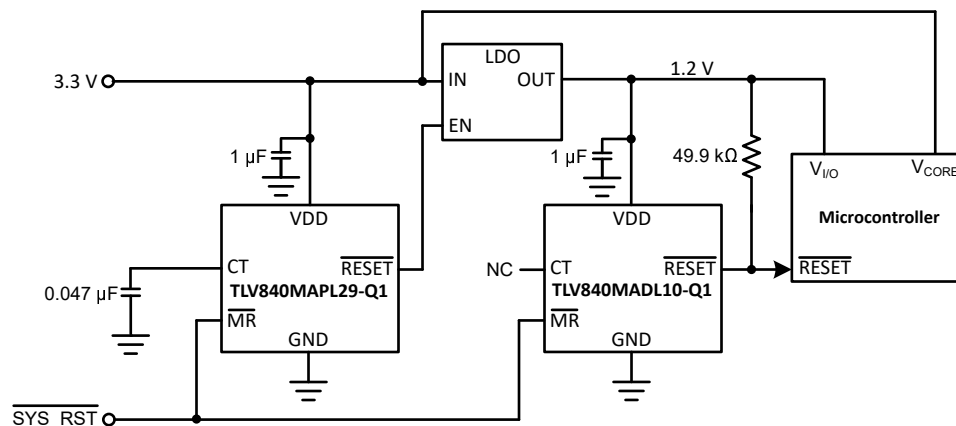

Figure 9-1. TLV840-Q1 Voltage Rail Monitor and Power-Up Sequencer Design Block Diagram

9.2.1.1 Design Requirements

This design requires voltage supervision on two separate rails: 3.3-V and 1.2-V rails. The voltage rail needs to sequence upon power up with the 3.3-V rail coming up first followed by the 1.2-V rail at least 25 ms after.

PARAMETER	DESIGN REQUIREMENT	DESIGN RESULT
Two Rail Voltage Supervision	Monitor 3.3-V and 1.2-V rails	Two TLV840-Q1 devices provide voltage monitoring with 1% accuracy with device options available in 0.1 V variations
Voltage Rail Sequencing	Power up the 3.3-V rail first followed by 1.2-V rail 25 ms after	The CT capacitor on TLV840MAPL29-Q1 is set to 0.047 μF for a reset time delay of 29 ms typical
Maximum device current consumption	1 μA	Each TLV840-Q1 requires 120 nA typical

9.2.1.2 Detailed Design Procedure

The primary constraint for this application is choosing the correct device to monitor the supply voltage of the microprocessor. The TLV840-Q1 can monitor any voltage between 0.8 V and 5.4 V. Depending on how far away from the nominal voltage rail the user wants the voltage supervisor to trigger determines the correct voltage supervisor variant to choose. In this example, the first TLV840-Q1 triggers when the 3.3-V rail falls to 2.9 V. The second TLV840-Q1 triggers a reset when the 1.2-V rail falls to 0.9 V. The secondary constraint for this application is the reset time delay that must be at least 25 ms to allow the microprocessor, and all other devices using the 3.3-V rail, enough time to startup correctly before the 1.2-V rail is enabled via the LDO. Because a minimum time is required, the user must account for capacitor tolerance. For applications with ambient temperatures ranging from -40°C to $+125^{\circ}\text{C}$, C_{CT} can be calculated using R_{CT} and solving for C_{CT} in Equation 2. Solving Equation 2 for 25 ms gives a minimum capacitor value of 0.0403 μF which is rounded up to a standard value 0.047 μF to account for capacitor tolerance.

A 1 μF decoupling capacitor is connected to the VDD pin as a good analog design practice. The pull-up resistor is only required for the Open-Drain device variants and is calculated to ensure that V_{OL} does not exceed max limit given the I_{sink} possible at the expected supply voltage. In this design example nominal VDD is 1.2 V but dropping to 0.9 V. In Section 7.5, max V_{OL} provides 15 μA I_{sink} for 0.7 V VDD, which is the closest voltage to this design example. Using 15 μA of I_{sink} and 300 mV max V_{OL} , gives us 40 k Ω for the pull-up resistor. Any value higher than 40 k Ω would ensure that V_{OL} will not exceed 300 mV max specification.

9.2.1.3 Application Curves



Figure 9-2. Startup Sequence Highlighting the Delay Between 3.3 V and 1.2 V Rails

9.2.2 Application Curve: Adjusting Output Reset Delay on TLV840EVM

These application curves are taken with the TLV840EVM and they display a change in reset delay time with different capacitor values. The output reset delay time was designed with the ease of programability for the customer. [Figure 9-3](#) displays an output reset delay time of 57.6 μs with no capacitor on the CT pin. [Figure 9-4](#) and [Figure 9-5](#) have output reset delay times of 5.42 ms and 56.8 ms, respectively. Both the output delay times and capacitors used resulted in an order of magnitude difference. Please see the [TLV840EVM User Guide](#) for more information.

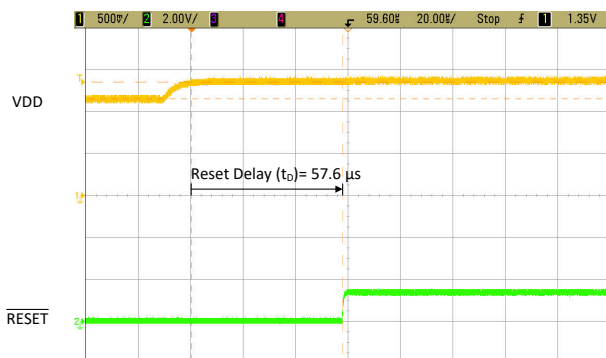

Figure 9-3. TLV840EVM RESET Time Delay (t_D) with No Capacitor

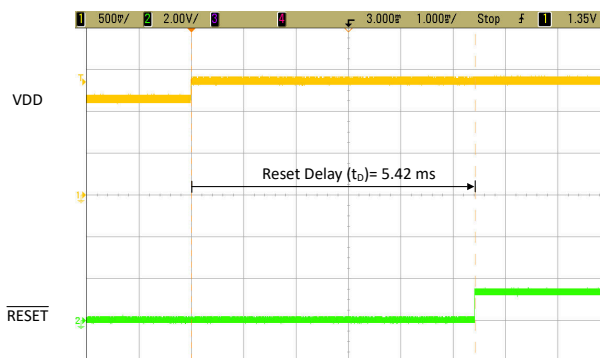

Figure 9-4. TLV840EVM RESET Time Delay (t_D) with 0.01- μF Capacitor

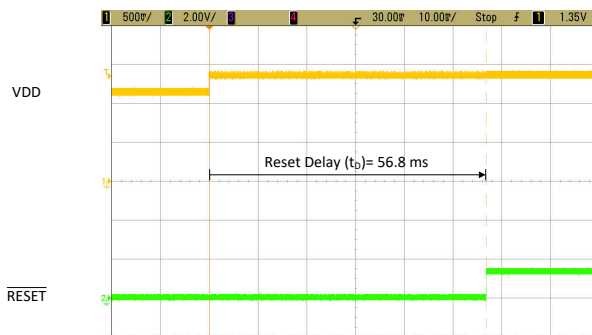

Figure 9-5. TLV840EVM RESET Time Delay (t_D) with 0.1- μF Capacitor

10 Power Supply Recommendations

The TLV840 is designed to operate from an input supply with a voltage range between 0.7 V and 6 V. TI recommends an input supply capacitor between the VDD pin and GND pin. This device has a 6.5 V absolute maximum rating on the VDD pin. If the voltage supply providing power to VDD is susceptible to any large voltage transient that can exceed 6.5 V, additional precautions must be taken.

11 Layout

11.1 Layout Guidelines

Make sure that the connection to the VDD pin is low impedance. Good analog design practice recommends placing a minimum 0.1 μF ceramic capacitor as near as possible to the VDD pin. If a capacitor is not connected to the CT pin, then minimize parasitic capacitance on this pin so the rest time delay is not adversely affected.

- Make sure that the connection to the VDD pin is low impedance. Good analog design practice is to place a > 0.1 μF ceramic capacitor as near as possible to the VDD pin.
- If a C_{CT} capacitor is used, place these components as close as possible to the CT pin. If the CT pin is left unconnected, make sure to minimize the amount of parasitic capacitance on the pin to < 5 pF.
- Place the pull-up resistors on $\overline{\text{RESET}}$ pin as close to the pin as possible.

11.2 Layout Example

The layout example in shows how the TLV840DL-Q1 is laid out on a printed circuit board (PCB) with a user-defined delay.

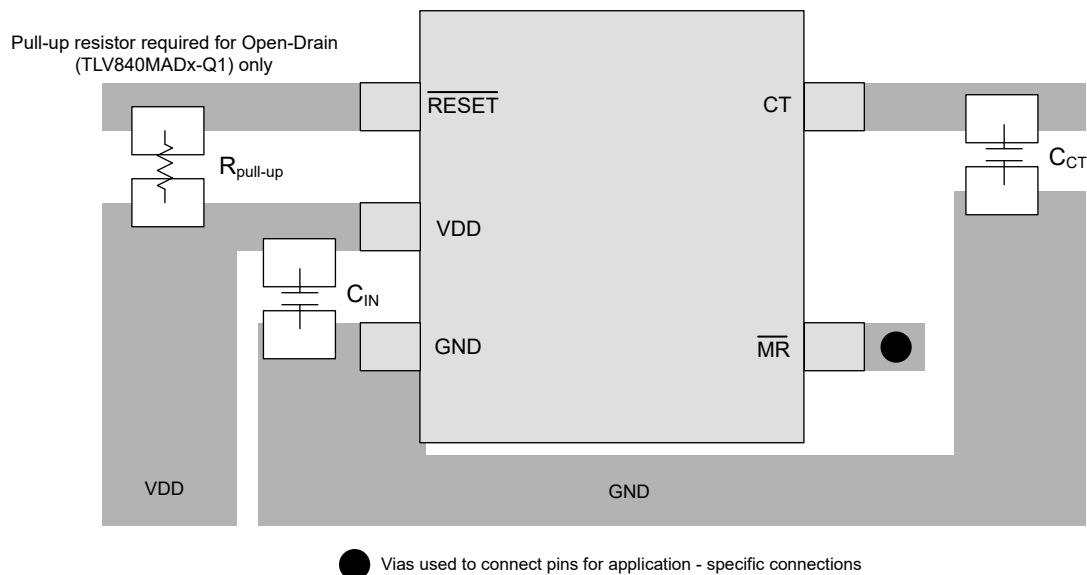

Figure 11-1. TLV840M-Q1 Recommended Layout

12 Device and Documentation Support

12.1 Device Nomenclature

Table 12-1 shows how to decode the function of the device based on its part number

Table 12-1. Device Naming Convention

DESCRIPTION	NOMENCLATURE	VALUE
Generic Part number	TLV840	TLV840
Feature Option	M 1	Manual Reset option in addition to CT pin
Delay Option	A	40 μ s (Default internal reset time delay)
Variant code (Output Topology)	DL	Open-Drain, Active-Low
	PL	Push-Pull, Active-Low
	DH	Open-Drain, Active-High
	PH	Push-Pull, Active-High
Detect Voltage Option	## (two characters)	Example: 12 stands for 1.2 V threshold
Package	DBV	SOT23-5
Reel	R	Large Reel
Automotive Version	Q1	AEC-Q100

- Orderable part numbers with TLV840M-Q1 are only available with the delay option A. However, longer delays can be achieved through an external capacitor on the CT pin. Leaving the CT pin floating will result in typical 40 μ s delay feature option.

12.2 Receiving Notification of Documentation Updates

To receive notification of documentation updates, navigate to the device product folder on ti.com. In the upper right corner, click on *Alert me* to register and receive a weekly digest of any product information that has changed. For change details, review the revision history included in any revised document.

12.3 Support Resources

12.4 Trademarks

All trademarks are the property of their respective owners.

13 Mechanical, Packaging, and Orderable Information

The following pages include mechanical, packaging, and orderable information. This information is the most current data available for the designated devices. This data is subject to change without notice and revision of this document. For browser-based versions of this data sheet, refer to the left-hand navigation.

PACKAGING INFORMATION

Orderable part number	Status (1)	Material type (2)	Package Pins	Package qty Carrier	RoHS (3)	Lead finish/ Ball material (4)	MSL rating/ Peak reflow (5)	Op temp (°C)	Part marking (6)
TLV840MADL12DBVRQ1	Active	Production	SOT-23 (DBV) 5	3000 LARGE T&R	Yes	NIPDAU SN	Level-1-260C-UNLIM	-40 to 125	2HNF
TLV840MADL12DBVRQ1.A	Active	Production	SOT-23 (DBV) 5	3000 LARGE T&R	Yes	NIPDAU	Level-1-260C-UNLIM	-40 to 125	2HNF
TLV840MADL12DBVRQ1.B	Active	Production	SOT-23 (DBV) 5	3000 LARGE T&R	-	Call TI	Call TI	-40 to 125	
TLV840MADL22DBVRQ1	Active	Production	SOT-23 (DBV) 5	3000 LARGE T&R	Yes	NIPDAU SN	Level-1-260C-UNLIM	-40 to 125	2HOF
TLV840MADL22DBVRQ1.A	Active	Production	SOT-23 (DBV) 5	3000 LARGE T&R	Yes	SN	Level-1-260C-UNLIM	-40 to 125	2HOF
TLV840MADL22DBVRQ1.B	Active	Production	SOT-23 (DBV) 5	3000 LARGE T&R	-	Call TI	Call TI	-40 to 125	
TLV840MADL29DBVRQ1	Active	Production	SOT-23 (DBV) 5	3000 LARGE T&R	Yes	NIPDAU SN	Level-1-260C-UNLIM	-40 to 125	3OZF
TLV840MADL29DBVRQ1.A	Active	Production	SOT-23 (DBV) 5	3000 LARGE T&R	Yes	NIPDAU	Level-1-260C-UNLIM	-40 to 125	3OZF
TLV840MADL30DBVRQ1	Active	Production	SOT-23 (DBV) 5	3000 LARGE T&R	Yes	NIPDAU SN	Level-1-260C-UNLIM	-40 to 125	2HPF
TLV840MADL30DBVRQ1.A	Active	Production	SOT-23 (DBV) 5	3000 LARGE T&R	Yes	NIPDAU	Level-1-260C-UNLIM	-40 to 125	2HPF
TLV840MADL30DBVRQ1.B	Active	Production	SOT-23 (DBV) 5	3000 LARGE T&R	-	Call TI	Call TI	-40 to 125	
TLV840MADL31DBVRQ1	Active	Production	SOT-23 (DBV) 5	3000 LARGE T&R	Yes	NIPDAU SN	Level-1-260C-UNLIM	-40 to 125	2HMF
TLV840MADL31DBVRQ1.A	Active	Production	SOT-23 (DBV) 5	3000 LARGE T&R	Yes	NIPDAU	Level-1-260C-UNLIM	-40 to 125	2HMF
TLV840MADL32DBVRQ1	Active	Production	SOT-23 (DBV) 5	3000 LARGE T&R	Yes	NIPDAU SN	Level-1-260C-UNLIM	-40 to 125	2HQF
TLV840MADL32DBVRQ1.A	Active	Production	SOT-23 (DBV) 5	3000 LARGE T&R	Yes	NIPDAU	Level-1-260C-UNLIM	-40 to 125	2HQF
TLV840MADL32DBVRQ1.B	Active	Production	SOT-23 (DBV) 5	3000 LARGE T&R	-	Call TI	Call TI	-40 to 125	
TLV840MADL40DBVRQ1	Active	Production	SOT-23 (DBV) 5	3000 LARGE T&R	Yes	NIPDAU SN	Level-1-260C-UNLIM	-40 to 125	2HDF
TLV840MADL40DBVRQ1.A	Active	Production	SOT-23 (DBV) 5	3000 LARGE T&R	Yes	NIPDAU	Level-1-260C-UNLIM	-40 to 125	2HDF
TLV840MADL40DBVRQ1.B	Active	Production	SOT-23 (DBV) 5	3000 LARGE T&R	-	Call TI	Call TI	-40 to 125	
TLV840MAPH29DBVRQ1	Active	Production	SOT-23 (DBV) 5	3000 LARGE T&R	Yes	NIPDAU SN	Level-1-260C-UNLIM	-40 to 125	2INF
TLV840MAPH29DBVRQ1.A	Active	Production	SOT-23 (DBV) 5	3000 LARGE T&R	Yes	SN	Level-1-260C-UNLIM	-40 to 125	2INF
TLV840MAPH29DBVRQ1.B	Active	Production	SOT-23 (DBV) 5	3000 LARGE T&R	-	Call TI	Call TI	-40 to 125	
TLV840MAPL36DBVRQ1	Active	Production	SOT-23 (DBV) 5	3000 LARGE T&R	Yes	NIPDAU SN	Level-1-260C-UNLIM	-40 to 125	2HVF
TLV840MAPL36DBVRQ1.A	Active	Production	SOT-23 (DBV) 5	3000 LARGE T&R	Yes	NIPDAU	Level-1-260C-UNLIM	-40 to 125	2HVF
TLV840MAPL36DBVRQ1.B	Active	Production	SOT-23 (DBV) 5	3000 LARGE T&R	-	Call TI	Call TI	-40 to 125	

⁽¹⁾ **Status:** For more details on status, see our [product life cycle](#).

(2) **Material type:** When designated, preproduction parts are prototypes/experimental devices, and are not yet approved or released for full production. Testing and final process, including without limitation quality assurance, reliability performance testing, and/or process qualification, may not yet be complete, and this item is subject to further changes or possible discontinuation. If available for ordering, purchases will be subject to an additional waiver at checkout, and are intended for early internal evaluation purposes only. These items are sold without warranties of any kind.

(3) **RoHS values:** Yes, No, RoHS Exempt. See the [TI RoHS Statement](#) for additional information and value definition.

(4) **Lead finish/Ball material:** Parts may have multiple material finish options. Finish options are separated by a vertical ruled line. Lead finish/Ball material values may wrap to two lines if the finish value exceeds the maximum column width.

(5) **MSL rating/Peak reflow:** The moisture sensitivity level ratings and peak solder (reflow) temperatures. In the event that a part has multiple moisture sensitivity ratings, only the lowest level per JEDEC standards is shown. Refer to the shipping label for the actual reflow temperature that will be used to mount the part to the printed circuit board.

(6) **Part marking:** There may be an additional marking, which relates to the logo, the lot trace code information, or the environmental category of the part.

Multiple part markings will be inside parentheses. Only one part marking contained in parentheses and separated by a "~" will appear on a part. If a line is indented then it is a continuation of the previous line and the two combined represent the entire part marking for that device.

Important Information and Disclaimer: The information provided on this page represents TI's knowledge and belief as of the date that it is provided. TI bases its knowledge and belief on information provided by third parties, and makes no representation or warranty as to the accuracy of such information. Efforts are underway to better integrate information from third parties. TI has taken and continues to take reasonable steps to provide representative and accurate information but may not have conducted destructive testing or chemical analysis on incoming materials and chemicals. TI and TI suppliers consider certain information to be proprietary, and thus CAS numbers and other limited information may not be available for release.

In no event shall TI's liability arising out of such information exceed the total purchase price of the TI part(s) at issue in this document sold by TI to Customer on an annual basis.

OTHER QUALIFIED VERSIONS OF TLV840-Q1 :

- Catalog : [TLV840](#)

NOTE: Qualified Version Definitions:

- Catalog - TI's standard catalog product

TAPE AND REEL INFORMATION

QUADRANT ASSIGNMENTS FOR PIN 1 ORIENTATION IN TAPE

*All dimensions are nominal

Device	Package Type	Package Drawing	Pins	SPQ	Reel Diameter (mm)	Reel Width W1 (mm)	A0 (mm)	B0 (mm)	K0 (mm)	P1 (mm)	W (mm)	Pin1 Quadrant
TLV840MADL12DBVRQ1	SOT-23	DBV	5	3000	180.0	8.4	3.2	3.2	1.4	4.0	8.0	Q3
TLV840MADL22DBVRQ1	SOT-23	DBV	5	3000	180.0	8.4	3.2	3.2	1.4	4.0	8.0	Q3
TLV840MADL29DBVRQ1	SOT-23	DBV	5	3000	180.0	8.4	3.2	3.2	1.4	4.0	8.0	Q3
TLV840MADL30DBVRQ1	SOT-23	DBV	5	3000	180.0	8.4	3.2	3.2	1.4	4.0	8.0	Q3
TLV840MADL31DBVRQ1	SOT-23	DBV	5	3000	180.0	8.4	3.2	3.2	1.4	4.0	8.0	Q3
TLV840MADL32DBVRQ1	SOT-23	DBV	5	3000	180.0	8.4	3.2	3.2	1.4	4.0	8.0	Q3
TLV840MADL40DBVRQ1	SOT-23	DBV	5	3000	180.0	8.4	3.2	3.2	1.4	4.0	8.0	Q3
TLV840MAPH29DBVRQ1	SOT-23	DBV	5	3000	180.0	8.4	3.2	3.2	1.4	4.0	8.0	Q3
TLV840MAPL36DBVRQ1	SOT-23	DBV	5	3000	180.0	8.4	3.2	3.2	1.4	4.0	8.0	Q3
TLV840MAPL36DBVRQ1	SOT-23	DBV	5	3000	180.0	8.4	3.2	3.2	1.4	4.0	8.0	Q3

TAPE AND REEL BOX DIMENSIONS

*All dimensions are nominal

Device	Package Type	Package Drawing	Pins	SPQ	Length (mm)	Width (mm)	Height (mm)
TLV840MADL12DBVRQ1	SOT-23	DBV	5	3000	210.0	185.0	35.0
TLV840MADL22DBVRQ1	SOT-23	DBV	5	3000	210.0	185.0	35.0
TLV840MADL29DBVRQ1	SOT-23	DBV	5	3000	210.0	185.0	35.0
TLV840MADL30DBVRQ1	SOT-23	DBV	5	3000	210.0	185.0	35.0
TLV840MADL31DBVRQ1	SOT-23	DBV	5	3000	210.0	185.0	35.0
TLV840MADL32DBVRQ1	SOT-23	DBV	5	3000	210.0	185.0	35.0
TLV840MADL40DBVRQ1	SOT-23	DBV	5	3000	210.0	185.0	35.0
TLV840MAPH29DBVRQ1	SOT-23	DBV	5	3000	210.0	185.0	35.0
TLV840MAPL36DBVRQ1	SOT-23	DBV	5	3000	210.0	185.0	35.0
TLV840MAPL36DBVRQ1	SOT-23	DBV	5	3000	210.0	185.0	35.0

EXAMPLE BOARD LAYOUT

DBV0005A

SOT-23 - 1.45 mm max height

SMALL OUTLINE TRANSISTOR



LAND PATTERN EXAMPLE
EXPOSED METAL SHOWN
SCALE:15X



SOLDER MASK DETAILS

4214839/K 08/2024

NOTES: (continued)

- 6. Publication IPC-7351 may have alternate designs.
- 7. Solder mask tolerances between and around signal pads can vary based on board fabrication site.

EXAMPLE STENCIL DESIGN

DBV0005A

SOT-23 - 1.45 mm max height

SMALL OUTLINE TRANSISTOR



SOLDER PASTE EXAMPLE
BASED ON 0.125 mm THICK STENCIL
SCALE:15X

4214839/K 08/2024

NOTES: (continued)

8. Laser cutting apertures with trapezoidal walls and rounded corners may offer better paste release. IPC-7525 may have alternate design recommendations.
9. Board assembly site may have different recommendations for stencil design.

IMPORTANT NOTICE AND DISCLAIMER

TI PROVIDES TECHNICAL AND RELIABILITY DATA (INCLUDING DATASHEETS), DESIGN RESOURCES (INCLUDING REFERENCE DESIGNS), APPLICATION OR OTHER DESIGN ADVICE, WEB TOOLS, SAFETY INFORMATION, AND OTHER RESOURCES "AS IS" AND WITH ALL FAULTS, AND DISCLAIMS ALL WARRANTIES, EXPRESS AND IMPLIED, INCLUDING WITHOUT LIMITATION ANY IMPLIED WARRANTIES OF MERCHANTABILITY, FITNESS FOR A PARTICULAR PURPOSE OR NON-INFRINGEMENT OF THIRD PARTY INTELLECTUAL PROPERTY RIGHTS.

These resources are intended for skilled developers designing with TI products. You are solely responsible for (1) selecting the appropriate TI products for your application, (2) designing, validating and testing your application, and (3) ensuring your application meets applicable standards, and any other safety, security, regulatory or other requirements.

These resources are subject to change without notice. TI grants you permission to use these resources only for development of an application that uses the TI products described in the resource. Other reproduction and display of these resources is prohibited. No license is granted to any other TI intellectual property right or to any third party intellectual property right. TI disclaims responsibility for, and you fully indemnify TI and its representatives against any claims, damages, costs, losses, and liabilities arising out of your use of these resources.

TI's products are provided subject to [TI's Terms of Sale](#), [TI's General Quality Guidelines](#), or other applicable terms available either on [ti.com](#) or provided in conjunction with such TI products. TI's provision of these resources does not expand or otherwise alter TI's applicable warranties or warranty disclaimers for TI products. Unless TI explicitly designates a product as custom or customer-specified, TI products are standard, catalog, general purpose devices.

TI objects to and rejects any additional or different terms you may propose.

Copyright © 2026, Texas Instruments Incorporated

Last updated 10/2025