

TLV902xL-Q1 and TLV903xL-Q1 Precision, Self-Latching Comparator Family

1 Features

- Qualified for automotive applications
- AEC-Q100 qualified with the following results:
 - Device temperature grade 1: -40°C to 125°C ambient operating temperature range
 - Device HBM ESD classification level 2
 - Device CDM ESD classification level C6
- Output latch with falling-edge triggered clear
- Power-on Reset (POR) for known start-up
- Selectable start-up state:
 - Unlatched on power-up (L1 option)
 - Latched on power-up (L2 option)
- Supply range: 1.65V to 5.5V
- Precision input offset voltage: $300\mu\text{V}$
- Rail-to-rail inputs with fault tolerance
- Typical propagation delay: 110ns
- Low quiescent current: $22\mu\text{A}$ per channel
- Open-drain output option (TLV902xL-Q1)
- Push-pull output option (TLV903xL-Q1)

2 Applications

- [Telematics eCall](#)
- [Automotive head unit](#)
- [Instrument cluster](#)
- [On-board \(OBC\) and wireless chargers](#)

3 Description

The TLV902xL-Q1 and TLV903xL-Q1 are a family of Automotive grade single and dual channel latching comparators. The family also offers low input offset voltage, power on reset (POR), and fault-tolerant rail-to-rail inputs. These devices have an excellent speed-to-power combination with a propagation delay of 110ns with a quiescent supply current of only $22\mu\text{A}$ per channel.

The unique feature of the TLV90xxL-Q1 is the output latching capability. The output latches upon the first threshold crossing, allowing capture of an event or

error condition without the full attention of a system controller. This feature allows events to be captured at start up while the system controller is still initializing or busy with other tasks. The falling-edge triggered clear input allows system controller to reset the latch after performing any needed tasks and meets safety-critical requirements. The L1 and L2 options define power-up latching behavior.

These comparators also feature fault-tolerant inputs that can go up to 6V without damage with no output phase inversion. This feature makes this family of comparators designed for precision voltage monitoring in harsh, noisy environments.

The TLV902xL-Q1 have an open-drain output that can be pulled up below or beyond the supply voltage, designed for ORing multiple outputs or level translation. Latching occurs on the high to low output transition.

The TLV903xL-Q1 have a push-pull output stage capable of sinking and sourcing up to 85mA to drive a capacitive load such as a MOSFET gate. Latching occurs on the low to high output transition.

The family is specified for the automotive temperature range of -40°C to $+125^{\circ}\text{C}$ and are available in standard leaded and leadless packages.

Package Information

PART NUMBER	PACKAGE ⁽¹⁾	PACKAGE SIZE ⁽²⁾
TLV9020Lx-Q1,	DCL (SC-70, 6)	2mm × 2.1mm
TLV9030Lx-Q1 (Single)	DBV (SOT-23, 6) ⁽³⁾	2.9mm × 2.8mm
	DSE (WSON, 6) ⁽³⁾	1.5mm × 1.5mm
TLV9022Lx-Q1, TLV9032Lx-Q1 (Dual)	DGS (VSSOP, 10) ⁽³⁾	3mm × 4.9mm
	RUG (X2QFN, 10)	1.5mm × 2mm

(1) For more information, see [Section 10](#).

(2) The package size (length × width) is a nominal value and includes pins, where applicable.

(3) Product preview (not Production Data).

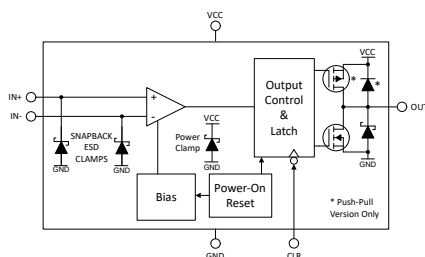

Simplified Block Diagram

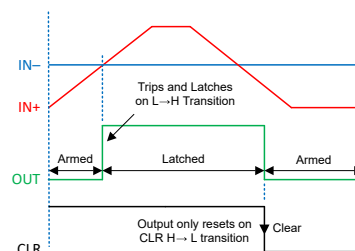

TLV903xL-Q1 Push-Pull Latching Response

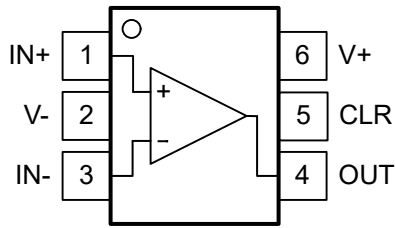

Table of Contents

1 Features	1	6.2 Functional Block Diagram.....	15
2 Applications	1	6.3 Feature Description.....	15
3 Description	1	6.4 Device Functional Modes.....	16
4 Pin Configuration and Functions	3	7 Application and Implementation	25
4.1 Pin Functions: TLV9020L-Q1 and TLV9030L-Q1 Single.....	3	7.1 Application Information.....	25
4.2 Pin Configurations: TLV9022L-Q1 and TLV9032L-Q1 Dual.....	4	7.2 Typical Applications.....	26
5 Specifications	5	7.3 Power Supply Recommendations.....	27
5.1 Absolute Maximum Ratings.....	5	7.4 Layout.....	27
5.2 ESD Ratings.....	5	8 Device and Documentation Support	28
5.3 Recommended Operating Conditions.....	5	8.1 Documentation Support.....	28
5.4 Thermal Information - Single.....	6	8.2 Receiving Notification of Documentation Updates....	28
5.5 Thermal Information - Dual.....	6	8.3 Support Resources.....	28
5.6 Electrical Characteristics.....	7	8.4 Trademarks.....	28
5.7 Switching Characteristics.....	8	8.5 Electrostatic Discharge Caution.....	28
5.8 Typical Characteristics.....	9	8.6 Glossary.....	28
6 Detailed Description	15	9 Revision History	28
6.1 Overview.....	15	10 Mechanical, Packaging, and Orderable Information	28

4 Pin Configuration and Functions

4.1 Pin Functions: TLV9020L-Q1 and TLV9030L-Q1 Single



**Figure 4-1. DCK and DBV Packages
 Standard *South East* Pinout with Clear Pin
 6-Pin SC-70 and SOT-23
 Top View**

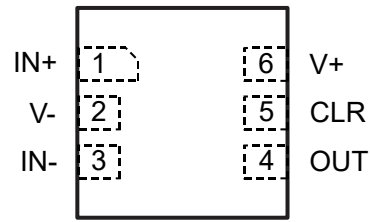

**Figure 4-2. DSE Package
 6-Pin WSON
 Top View**

Table 4-1. Pin Functions: TLV9020L-Q1 and TLV9030L-Q1

NAME	TLV9020L-Q1, TLV9030L-Q1			TYPE ⁽¹⁾	DESCRIPTION
	PINS	PINS	PINS		
	SC-70	SOT-23	WSON		
IN+	1	1	1	I	Non-inverting (+) input
V-	2	2	2	—	Negative supply voltage
IN-	3	3	3	I	Inverting (-) input
OUT	4	4	4	O	Output
CLR	5	5	5	I	Clear input - clears on falling edge
V+	6	6	6	—	Positive supply voltage

(1) Signal Types: I = Input, O = Output

4.2 Pin Configurations: TLV9022L-Q1 and TLV9032L-Q1 Dual

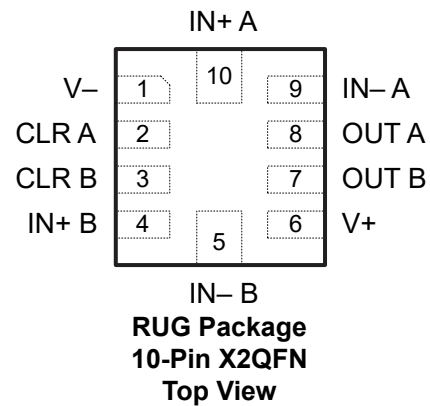
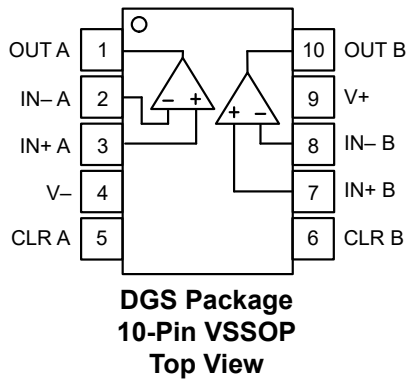

Table 4-2. Pin Functions: TLV9022L-Q1 and TLV9032L-Q1

NAME	TLV9022L-Q1, TLV9032L-Q1		TYPE ⁽¹⁾	DESCRIPTION
	PINS	PINS		
	VSSOP	X2QFN		
OUT A	1	8	O	Output of comparator A
IN- A	2	9	I	Inverting (-) input of comparator A
IN+ A	3	10	I	Non-Inverting (+) input of comparator A
V-	4	1	—	Negative supply voltage
CLR A	5	2	I	Clear input for comparator A - clears on falling edge
CLR B	6	3	I	Clear input for comparator B - clears on falling edge
IN+ B	7	4	I	Non-inverting (+) input of comparator B
IN- B	8	5	I	Inverting (-) input of comparator B
V+	9	6	—	Positive supply voltage
OUT B	10	7	O	Output of comparator B

(1) Signal Types: I = Input, O = Output

5 Specifications

5.1 Absolute Maximum Ratings

over operating free-air temperature range (unless otherwise noted)⁽¹⁾

	MIN	MAX	UNIT
Supply voltage: $V_S = (V+) - (V-)$	-0.3	6	V
Input pins (IN+, IN-, CLR) from (V-) ⁽²⁾	-0.3	6	V
Current into Input pins (IN+, IN-, CLR)	-10	10	mA
Output (OUT) from (V-) ⁽³⁾	-0.3	6	V
Output (OUT) (Open Drain) from (V-)	-0.3	(V+) + 0.3	V
Output short circuit duration ⁽⁴⁾		10	s
Junction temperature, T_J		150	°C
Storage temperature, T_{stg}	-65	150	°C

- (1) Operation outside the *Absolute Maximum Ratings* may cause permanent device damage. *Absolute Maximum Ratings* do not imply functional operation of the device at these or any other conditions beyond those listed under *Recommended Operating Conditions*. If used outside the *Recommended Operating Conditions* but within the *Absolute Maximum Ratings*, the device may not be fully functional, and this may affect device reliability, functionality, performance, and shorten the device lifetime.
- (2) Input terminals are diode-clamped to (V-). Input signals that can swing more than 0.3V beyond (V-) must be current-limited to 10mA or less. Additionally, Inputs (IN+, IN-, CLR) can be greater than (V+) and OUT as long as the voltage is within the -0.3V to 6V range
- (3) Output (OUT) for open drain can be greater than (V+)
- (4) Short-circuit to (V-) or (V+).

5.2 ESD Ratings

			VALUE	UNIT
$V_{(ESD)}$	Electrostatic discharge	Human-body model (HBM), per AEC Q100-002 ⁽¹⁾	±2000	V
		Charged-device model (CDM), per AEC Q100-0111	±1000	

- (1) AEC Q100-002 indicates that HBM stressing shall be in accordance with the ANSI/ESDA/JEDEC JS-001 specification.

5.3 Recommended Operating Conditions

over operating free-air temperature range (unless otherwise noted)

	MIN	MAX	UNIT
Supply voltage: $V_S = (V+) - (V-)$	1.65	5.5	V
Input voltage range (IN+, IN-, CLR) from (V-)	-0.2	5.5	V
Input common mode voltage range (IN+, IN-) from (V-)	-0.2	(V+) + 0.2	V
Output voltage range, open drain output, from (V-)	0	5.5	V
Output voltage range, push-pull output	(V-)	(V+)	V
Ambient Temperature, T_A	-40	125	°C

5.4 Thermal Information - Single

THERMAL METRIC ⁽¹⁾		TLV9020L-Q1, TLV9030-Q1			UNIT
		DBV (SOT-23)	DCK (SC-70)	DSE (WSON)	
		6 PINS	6 PINS	6 PINS	
R _{qJA}	Junction-to-ambient thermal resistance	181.2	210.5	-	°C/W
R _{qJC(top)}	Junction-to-case (top) thermal resistance	99.6	143.9	-	°C/W
R _{qJB}	Junction-to-board thermal resistance	63.1	64.7	-	°C/W
Y _{JT}	Junction-to-top characterization parameter	38.7	46.1	-	°C/W
Y _{JB}	Junction-to-board characterization parameter	62.9	64.5	-	°C/W
R _{qJC(bot)}	Junction-to-case (bottom) thermal resistance	-	-	-	°C/W

(1) For more information about traditional and new thermal metrics, see the [Semiconductor and IC Package Thermal Metrics](#) note.

5.5 Thermal Information - Dual

THERMAL METRIC ⁽¹⁾		TLV9022L-Q1, TLV9032-Q1		UNIT
		DGS (VSSOP)	RUG (X2QFN)	
		10 PINS	10 PINS	
R _{qJA}	Junction-to-ambient thermal resistance	-	222.8	°C/W
R _{qJC(top)}	Junction-to-case (top) thermal resistance	-	94.2	°C/W
R _{qJB}	Junction-to-board thermal resistance	-	147.1	°C/W
Y _{JT}	Junction-to-top characterization parameter	-	3.4	°C/W
Y _{JB}	Junction-to-board characterization parameter	-	146.4	°C/W
R _{qJC(bot)}	Junction-to-case (bottom) thermal resistance	-	-	°C/W

(1) For more information about traditional and new thermal metrics, see the [Semiconductor and IC Package Thermal Metrics](#) note.

5.6 Electrical Characteristics

For V_S (Total Supply Voltage) = $(V+) - (V-) = 5V$, $V_{CM} = (V-)$ at $T_A = 25^\circ C$ (Unless otherwise noted)

PARAMETER		TEST CONDITIONS	MIN	TYP	MAX	UNIT
OFFSET VOLTAGE						
V_T	Input threshold voltage	$V_S = 1.8V$ and $5V$	-1.75	± 0.3	1.75	mV
V_T	Input threshold voltage	$V_S = 1.8V$ and $5V$, $T_A = -40^\circ C$ to $+125^\circ C$	-2.25		2.25	
dV_T/dT	Input threshold voltage drift	$V_S = 1.8V$ and $5V$, $T_A = -40^\circ C$ to $+125^\circ C$		± 0.5		$\mu V/^\circ C$
POWER SUPPLY						
I_Q	Quiescent current per comparator	$V_S = 1.8V$ and $5V$, No Load, Output Low		22	30	μA
I_Q	Quiescent current per comparator	$V_S = 1.8V$ and $5V$, No Load, Output Low, $T_A = -40^\circ C$ to $+125^\circ C$			42	
V_{POR} (postive)	Power-On Reset Voltage			1.25		V
PSRR	Power-supply rejection ratio	$V_S = 1.8V$ to $5V$, $T_A = -40^\circ C$ to $+125^\circ C$ (push-pull only)	75	95		dB
PSRR	Power-supply rejection ratio	$V_S = 1.8V$ to $5V$, $T_A = -40^\circ C$ to $+125^\circ C$ (open drain only)	80	95		dB
INPUT BIAS CURRENT						
I_B	Input bias current	$V_{CM} = V_S/2$		5		pA
I_{OS}	Input offset current	$V_{CM} = V_S/2$		1		pA
INPUT CAPACITANCE						
C_{ID}	Input Capacitance, Differential	$V_{CM} = V_S/2$		2		pF
C_{IC}	Input Capacitance, Common Mode	$V_{CM} = V_S/2$		3		pF
INPUT VOLTAGE RANGE						
V_{IH_CLR}	Voltage input high threshold of CLR		1.2			V
V_{IL_CLR}	Voltage input low of threshold CLR				0.6	V
V_{CM_Range}	Common-mode voltage range	$V_S = 1.8V$ and $5V$, $T_A = -40^\circ C$ to $+125^\circ C$	$(V-) - 0.2$		$(V+) + 0.2$	V
CMRR	Common-mode rejection ratio	$V_S = 5V$, $(V-) - 0.2V < V_{CM} < (V+) + 0.2V$, $T_A = -40^\circ C$ to $+125^\circ C$	60	70		dB
CMRR	Common-mode rejection ratio	$V_S = 1.8V$, $(V-) - 0.2V < V_{CM} < (V+) + 0.2V$, $T_A = -40^\circ C$ to $+125^\circ C$	50	60		dB
OUTPUT						
V_{OL}	Voltage swing from (V-)	$I_{SINK} = 4mA$, $T_A = 25^\circ C$		75	125	mV
V_{OL}	Voltage swing from (V-)	$I_{SINK} = 4mA$, $T_A = -40^\circ C$ to $+125^\circ C$			175	mV
V_{OH}	Voltage swing from (V+)	$I_{SOURCE} = 4mA$, $T_A = 25^\circ C$ (push-pull only)		75	125	mV
V_{OH}	Voltage swing from (V+)	$I_{SOURCE} = 4mA$, $T_A = -40^\circ C$ to $+125^\circ C$ (push-pull only)			175	mV
I_{LKG}	Open-drain output leakage current	$V_{PULLUP} = (V+)$, $T_A = 25^\circ C$		100		pA
I_{SC}	Short-circuit current	$V_S = 5V$, Sinking	75	85		mA
I_{SC}	Short-circuit current	$V_S = 5V$, Sourcing (push-pull only)	75	85		mA

5.7 Switching Characteristics

$V_S = 5V$, $CLR = 5V_{PP}$, $V_L = 0V$, $V_H = 5V$, 2.5V DC offset, $V_{CM} = V_S/2$, $C_L = 15pF$ at $T_A = 25^\circ C$ (Unless otherwise noted)

PARAMETER		TEST CONDITIONS	MIN	TYP	MAX	UNIT
OUTPUT						
T_{PD-HL}	Propagation delay time, high-to-low, open-drain only	$V_{ID} = -100mV$, $CLR = 0V$, Delay from mid-point of input to mid-point of output, $R_P = 2.5K\Omega$		110		ns
T_{PD-LH}	Propagation delay time, low-to-high, push-pull only	$V_{ID} = +100mV$, $CLR = 0V$, Delay from mid-point of input to mid-point of output		125		ns
$T_{PD-CLR-F}$	Clear Fall to Latch Reset propagation delay time	$CLR = 1.8V$ to $5V$, Delay from CLR falling edge signal to unlatched output condition		25	70	ns
CLR_{Min}	Minimum Clear Hold Pulse time to register latch disable and transition output state	$CLR = 1.8V$ to $5V$, Minimum CLR pulse size required to register a change of state (latch reset) upon CLR falling edge	10			ns
T_{FALL}	5V Output Fall Time, 80% to 20%	$V_{ID} = -100mV$		3		ns
T_{RISE}	5V Output Rise Time, 20% to 80%	$V_{ID} = +100mV$, push-pull only		3		ns
POWER ON TIME						
P_{ON}	Power on-time			35		μs

5.8 Typical Characteristics

$T_A = 25^\circ\text{C}$, $V_S = 5\text{V}$, $R_{\text{PULLUP}} = 5.1\text{k}$ to 5V (push-pull only), $C_L = 15\text{pF}$, $V_{\text{CM}} = 0\text{V}$, $V_{\text{UNDERDRIVE}} = 100\text{mV}$, $V_{\text{OVERDRIVE}} = 100\text{mV}$ unless otherwise noted.

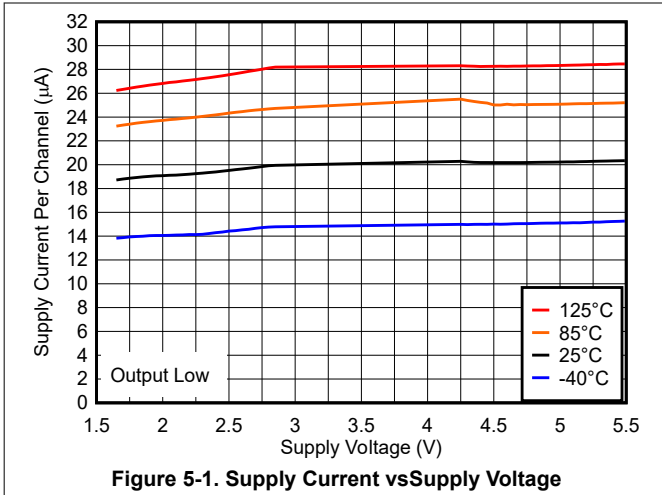

Figure 5-1. Supply Current vs Supply Voltage

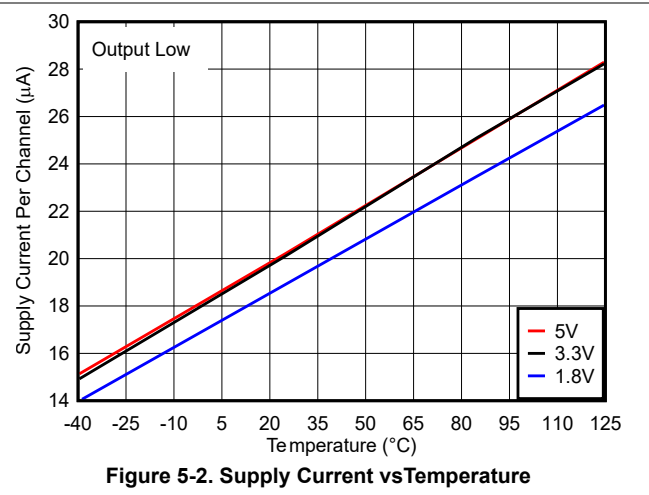

Figure 5-2. Supply Current vs Temperature

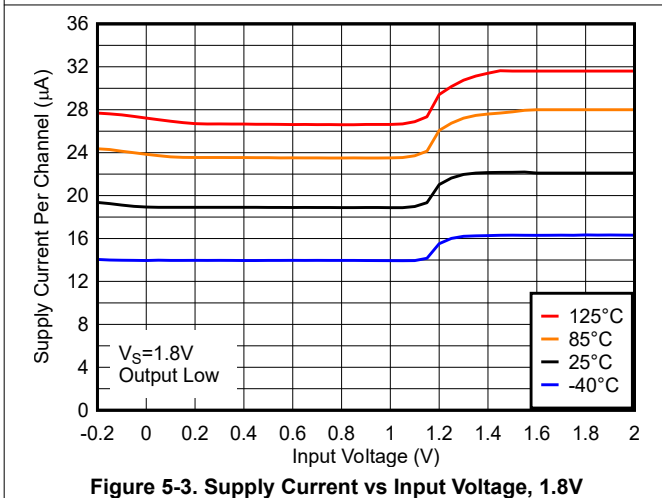

Figure 5-3. Supply Current vs Input Voltage, 1.8V

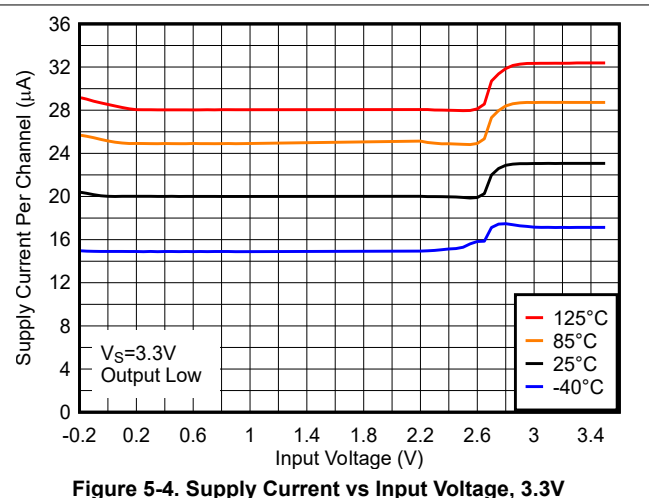

Figure 5-4. Supply Current vs Input Voltage, 3.3V

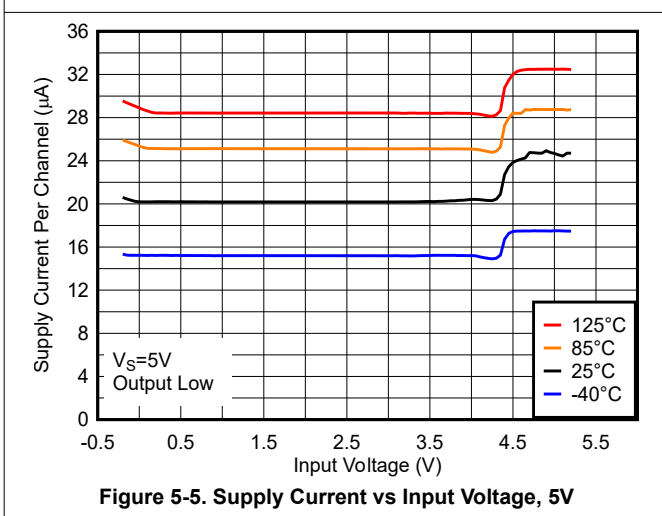

Figure 5-5. Supply Current vs Input Voltage, 5V

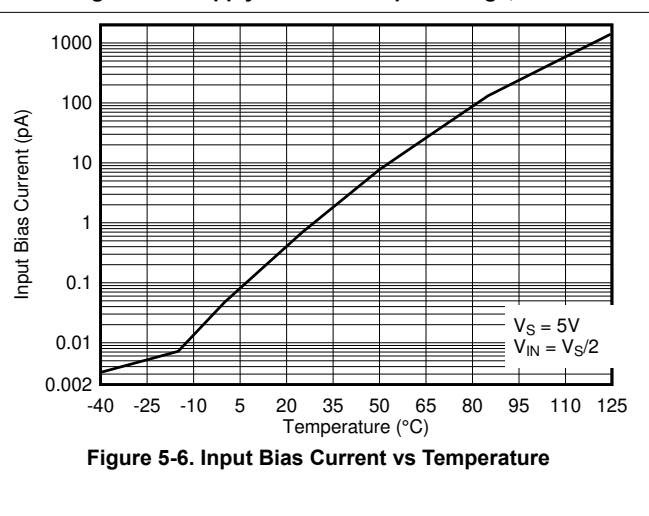

Figure 5-6. Input Bias Current vs Temperature

5.8 Typical Characteristics (continued)

$T_A = 25^\circ\text{C}$, $V_S = 5\text{V}$, $R_{\text{PULLUP}} = 5.1\text{k}$ to 5V (push-pull only), $C_L = 15\text{pF}$, $V_{\text{CM}} = 0\text{V}$, $V_{\text{UNDERDRIVE}} = 100\text{mV}$, $V_{\text{OVERDRIVE}} = 100\text{mV}$ unless otherwise noted.

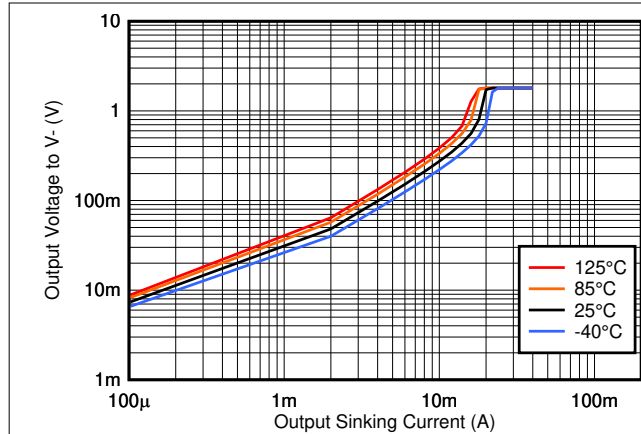

Figure 5-7. Output Sinking Current vs Output Voltage, 1.8V

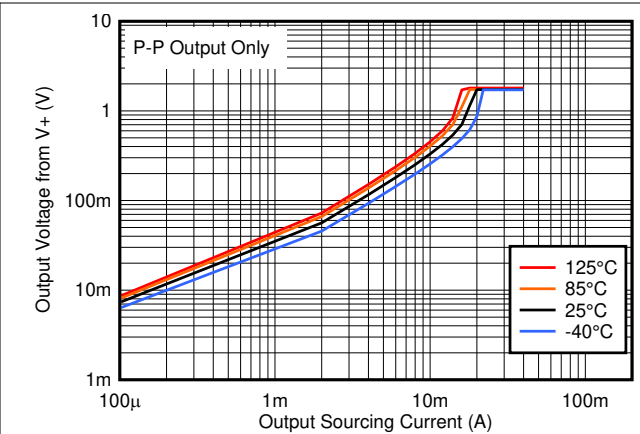

Figure 5-8. Output Sourcing Current vs Output Voltage, 1.8V

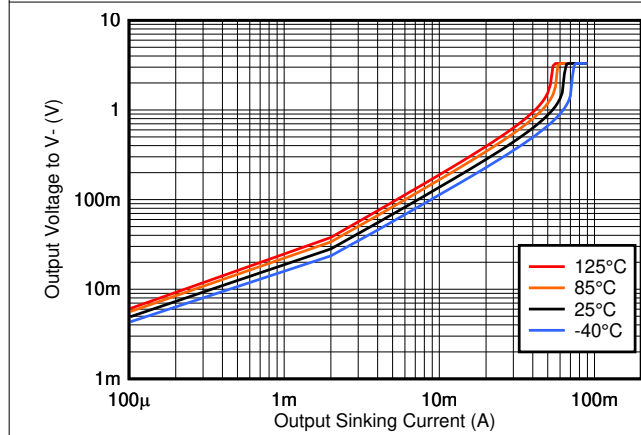

Figure 5-9. Output Sinking Current vs Output Voltage, 3.3V

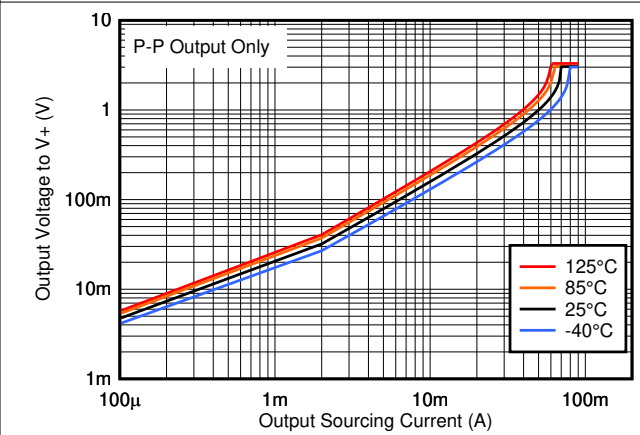

Figure 5-10. Output Sourcing Current vs Output Voltage, 3.3V

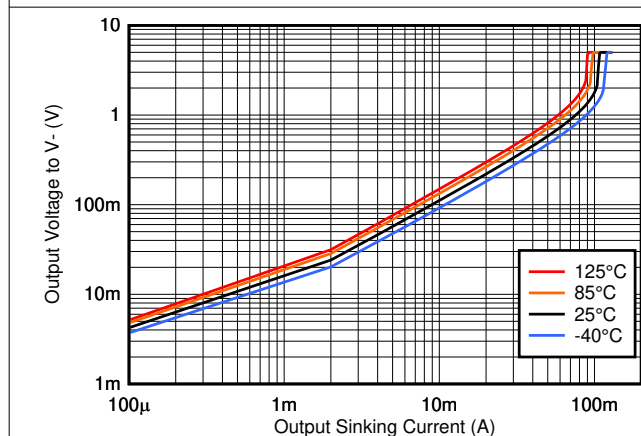

Figure 5-11. Output Sinking Current vs Output Voltage, 5V

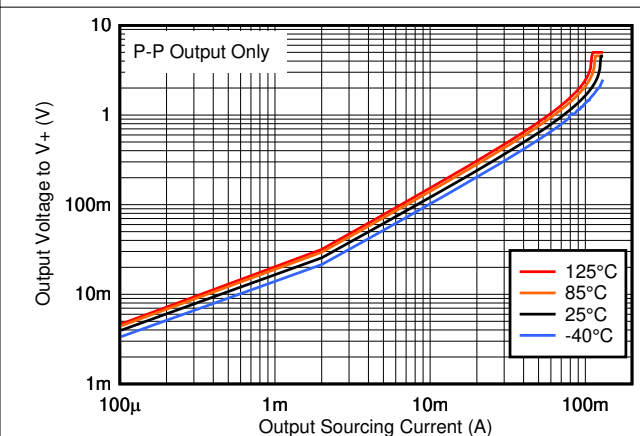

Figure 5-12. Output Sourcing Current vs Output Voltage, 5V

5.8 Typical Characteristics (continued)

$T_A = 25^\circ\text{C}$, $V_S = 5\text{V}$, $R_{\text{PULLUP}} = 5.1\text{k}$ to 5V (push-pull only), $C_L = 15\text{pF}$, $V_{\text{CM}} = 0\text{V}$, $V_{\text{UNDERDRIVE}} = 100\text{mV}$, $V_{\text{OVERDRIVE}} = 100\text{mV}$ unless otherwise noted.

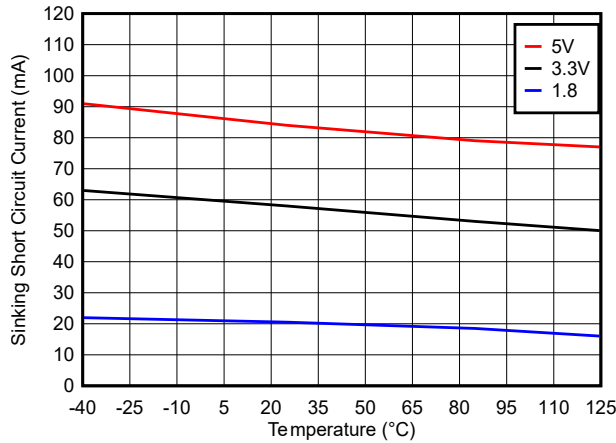

Figure 5-13. Sinking Short Circuit Current vs Temperature

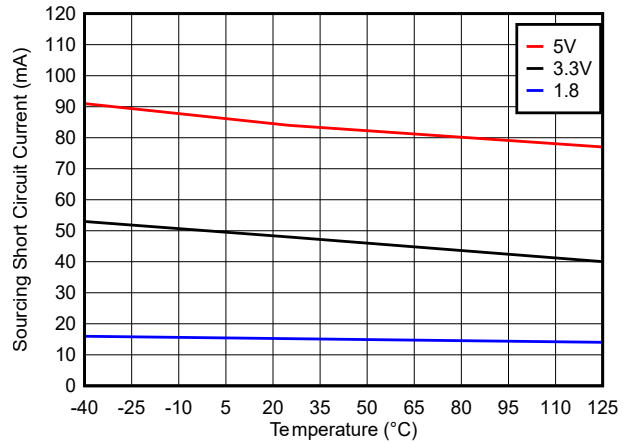

Figure 5-14. Sourcing Short Circuit Current vs Temperature

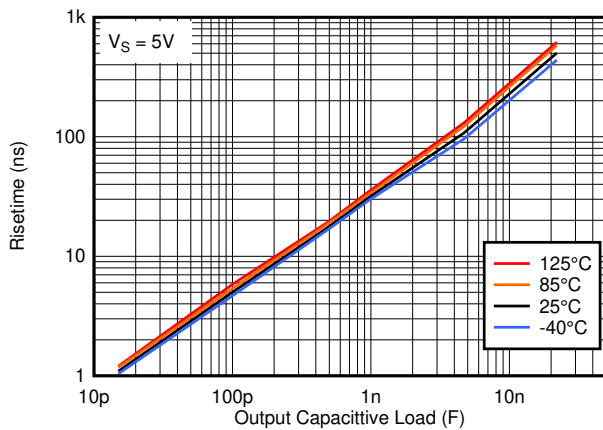

Figure 5-15. Risettime vs Capacitive Load

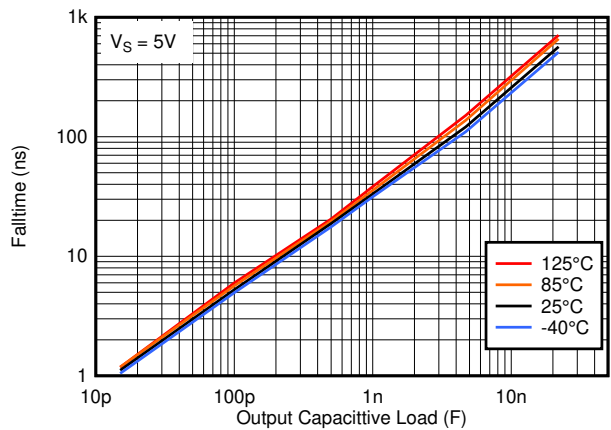

Figure 5-16. Falltime vs Capacitive Load

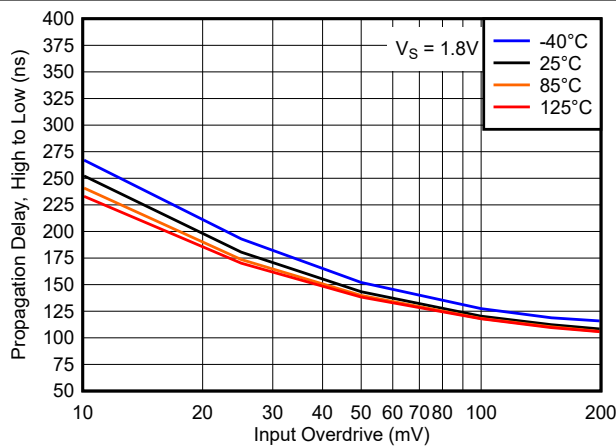

Figure 5-17. Propagation Delay, High to Low, 1.8V

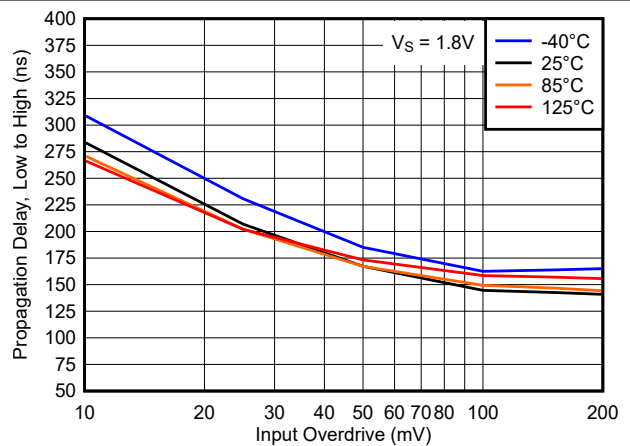

Figure 5-18. Propagation Delay, Low to High, 1.8V

5.8 Typical Characteristics (continued)

$T_A = 25^\circ\text{C}$, $V_S = 5\text{V}$, $R_{PULLUP} = 5.1\text{k}$ to 5V (push-pull only), $C_L = 15\text{pF}$, $V_{CM} = 0\text{V}$, $V_{UNDERDRIVE} = 100\text{mV}$, $V_{OVERDRIVE} = 100\text{mV}$ unless otherwise noted.

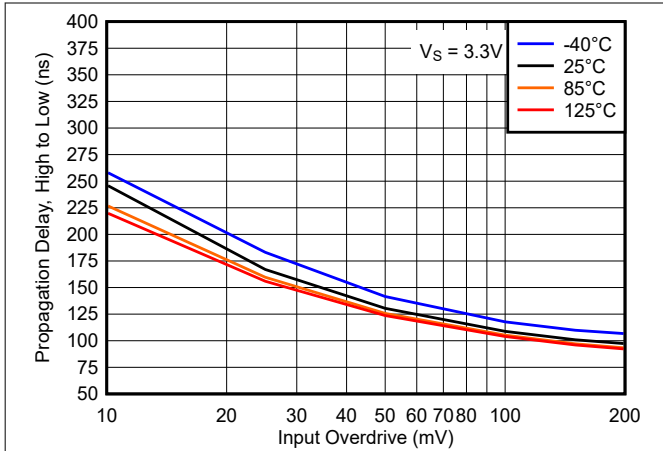

Figure 5-19. Propagation Delay, High to Low, 3.3V

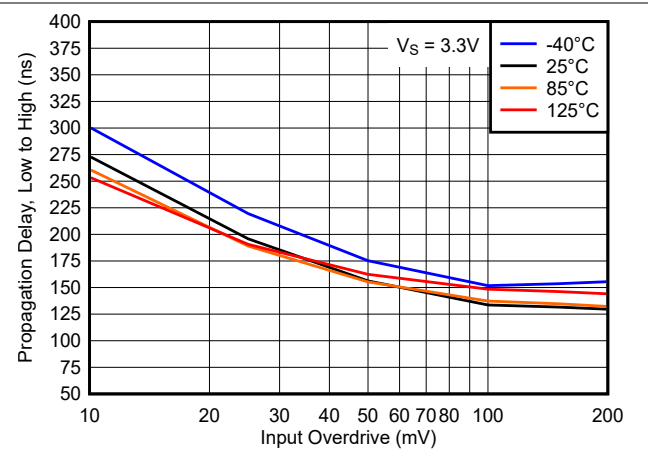

Figure 5-20. Propagation Delay, Low to High, 3.3V

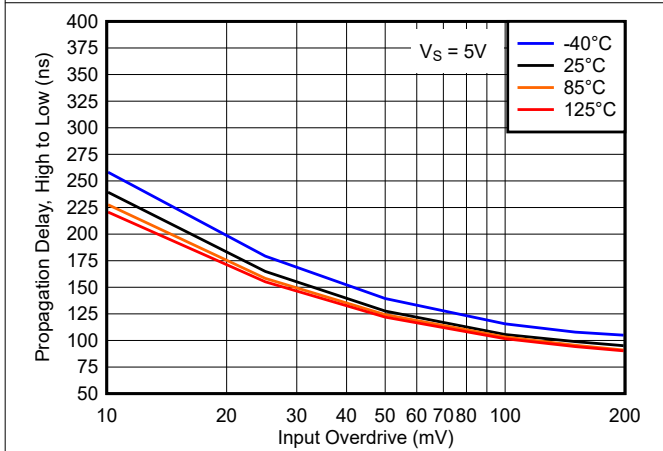

Figure 5-21. Propagation Delay, High to Low, 5V

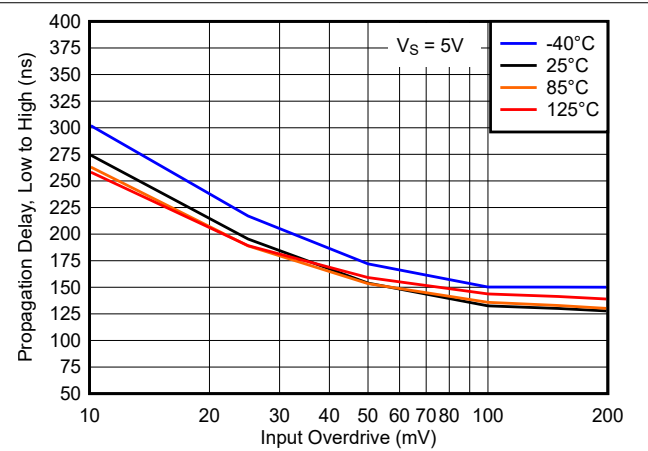

Figure 5-22. Propagation Delay, Low to High, 5V

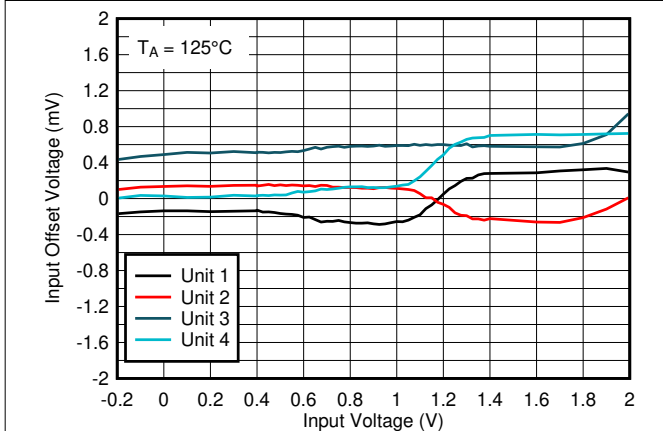

Figure 5-23. Offset Voltage vs Input Voltage at 125°C , 1.8V

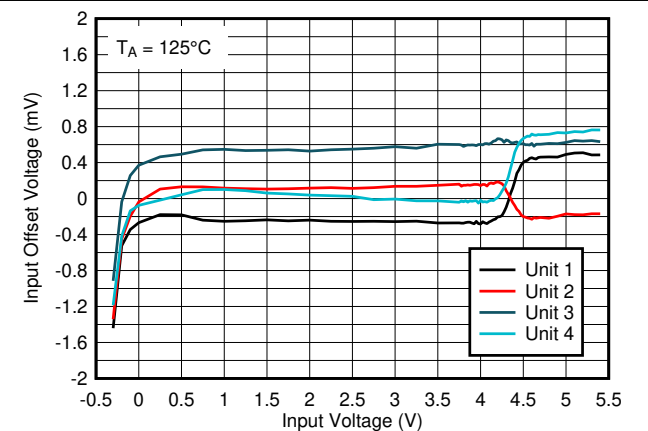

Figure 5-24. Offset Voltage vs Input Voltage at 125°C , 5V

5.8 Typical Characteristics (continued)

$T_A = 25^\circ\text{C}$, $V_S = 5\text{V}$, $R_{\text{PULLUP}} = 5.1\text{k}$ to 5V (push-pull only), $C_L = 15\text{pF}$, $V_{\text{CM}} = 0\text{V}$, $V_{\text{UNDERDRIVE}} = 100\text{mV}$, $V_{\text{OVERDRIVE}} = 100\text{mV}$ unless otherwise noted.

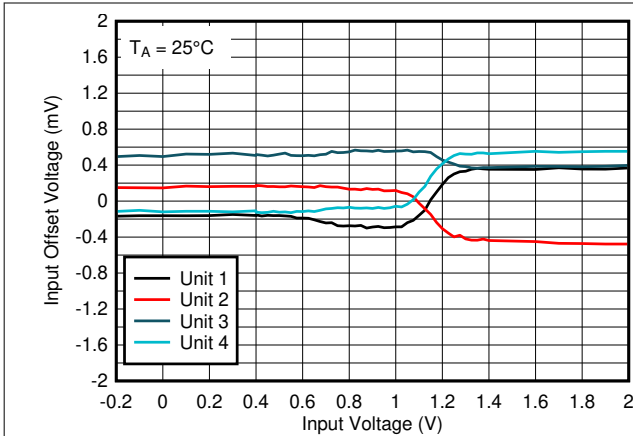

Figure 5-25. Offset Voltage vs Input Voltage at 25°C, 1.8V

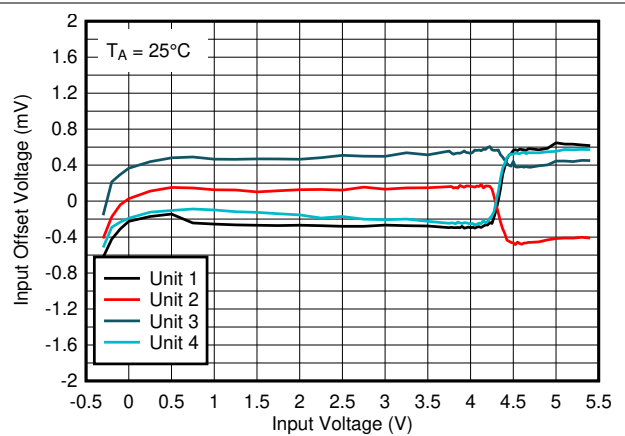

Figure 5-26. Offset Voltage vs Input Voltage at 25°C, 5V

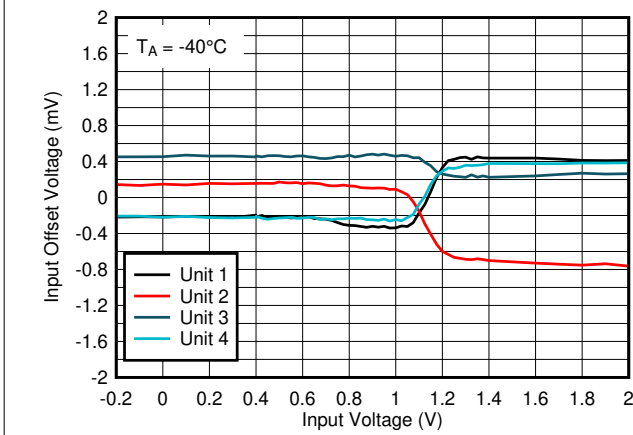

Figure 5-27. Offset Voltage vs Input Voltage at -40°C, 1.8V

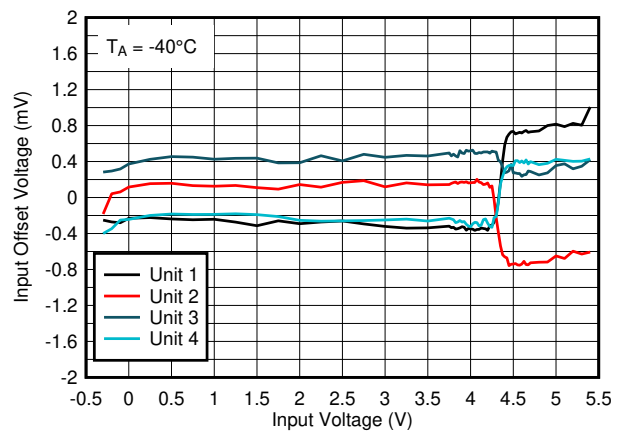

Figure 5-28. Offset Voltage vs Input Voltage at -40°C, 5V

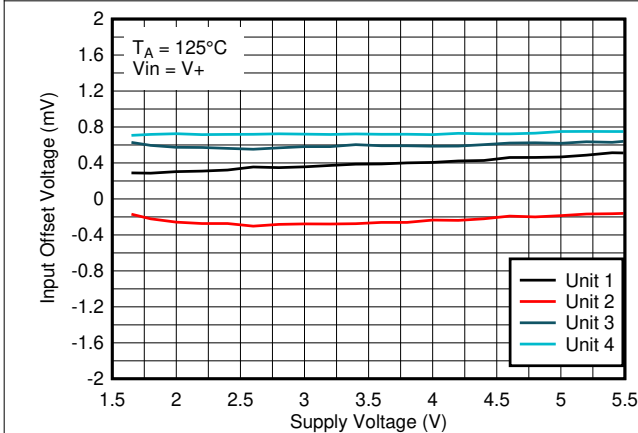

Figure 5-29. Offset Voltage vs Supply Voltage at 125°C, $V_{\text{IN}} = V^+$

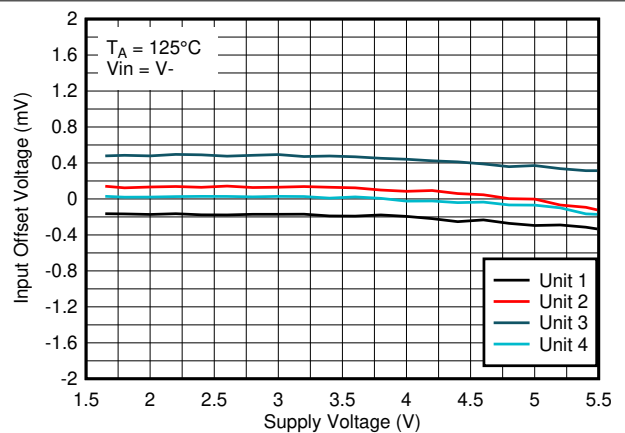

Figure 5-30. Offset Voltage vs Supply Voltage at 125°C, $V_{\text{IN}} = V^-$

5.8 Typical Characteristics (continued)

$T_A = 25^\circ\text{C}$, $V_S = 5\text{V}$, $R_{\text{PULLUP}} = 5.1\text{k}$ to 5V (push-pull only), $C_L = 15\text{pF}$, $V_{\text{CM}} = 0\text{V}$, $V_{\text{UNDERDRIVE}} = 100\text{mV}$, $V_{\text{OVERDRIVE}} = 100\text{mV}$ unless otherwise noted.

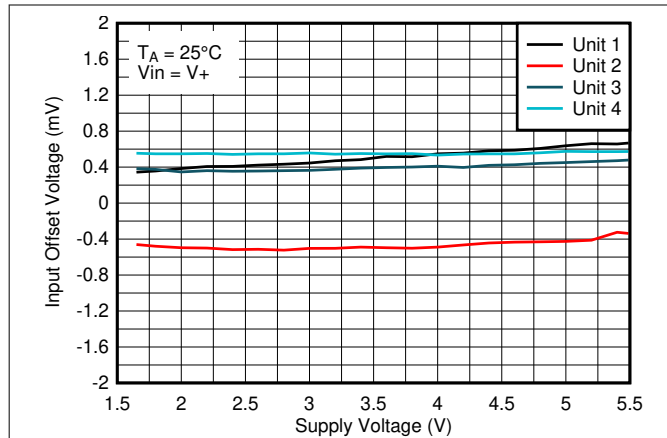

Figure 5-31. Offset Voltage vs Supply Voltage at 25°C , $V_{\text{IN}} = V+$

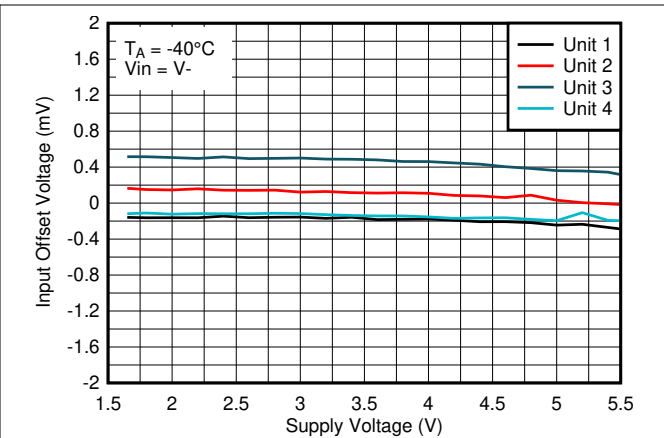

Figure 5-32. Offset Voltage vs Supply Voltage at 25°C , $V_{\text{IN}} = V-$

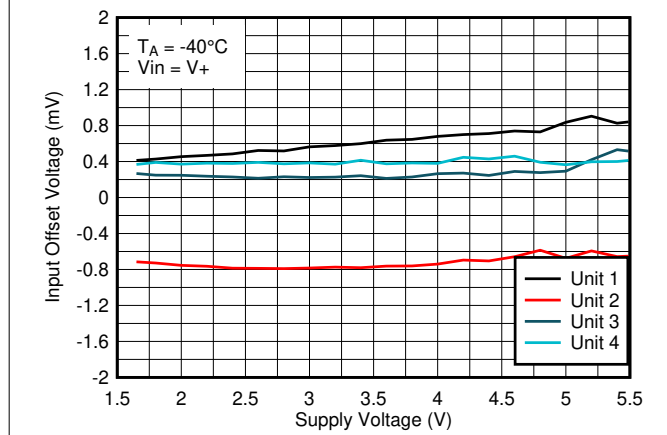

Figure 5-33. Offset Voltage vs Supply Voltage at -40°C , $V_{\text{IN}} = V+$

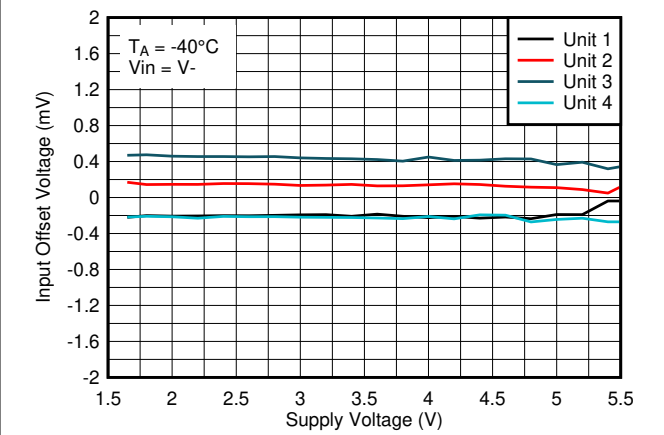

Figure 5-34. Offset Voltage vs Supply Voltage at -40°C , $V_{\text{IN}} = V-$

6 Detailed Description

6.1 Overview

The TLV902xL-Q1 and TLV903xL-Q1 are a family of single and dual channel latching comparators. The family offers low input offset voltage, power on reset (POR), fault-tolerant inputs and an excellent speed-to-power combination with a propagation delay of 110ns with a quiescent supply current of 22 μ A per channel.

6.2 Functional Block Diagram

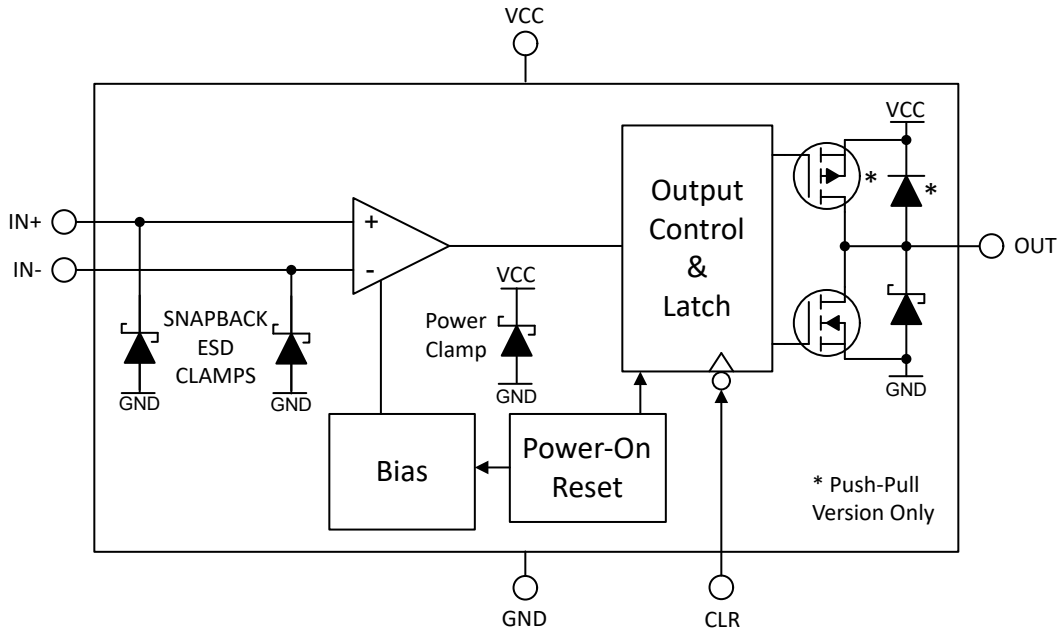

6.3 Feature Description

The unique feature of the TLV902xL-Q1 and TLV903xL-Q1 is the output latching capability. The output latches upon the first threshold crossing to allow capturing of an event or error condition without the full attention of a system controller. This allows events to be captured at start up while the system controller is still initializing. The system controller can reset the latch after performing any needed tasks. The user has the option of the output being un-latched at power-on ("L1" option), or latched at power-up ("L2" option).

These comparators also feature fault-tolerant inputs that can go up to 6V without damage with no output phase inversion. This makes this family of comparators designed for precision voltage monitoring in harsh, noisy environments.

6.4 Device Functional Modes

6.4.1 Outputs

6.4.1.1 TLV902xL-Q1 Open-Drain Output

The TLV902xL-Q1 features an open-drain (also commonly called open collector) sinking-only output stage enabling the output logic levels to be pulled up to any voltage up to 5.5V, independent of the comparator supply voltage (V_S). The open-drain output also allows logical ORing of multiple open drain outputs and logic level translation.

TI recommends setting the pull-up resistor current to between 100 μ A and 1mA. Lower pull-up resistor values helps decrease the rising edge rise time, but at the expense of increasing V_{OL} and higher power dissipation. The rise time is dependent on the time constant of the total pull-up resistance and total load capacitance. Large value pull-up resistors ($> 1M\Omega$) creates an exponential rising edge due to the RC time constant and increase the rise time.

Unused open drain outputs can be left floating, or can be tied to the V_- pin if floating pins are not allowed.

The open drain output protection is an ESD clamp between the output and V_- to allow the output to be pulled to a maximum voltage of 5.5V, even if the pullup voltage exceeds V_S .

6.4.1.2 TLV903xL-Q1 Push-Pull Output

The TLV903xL-Q1 features a push-pull output stage capable of both sinking and sourcing current. This feature allows driving loads such as LED's and MOSFET gates, as well as eliminating the need for a power-wasting external pullup resistor and provides symmetrical edge rates independent of capacitive load.

The push-pull output must never be connected to another output. Directly shorting the output to the opposite supply can result in thermal runaway and eventual device destruction. If output shorts are possible, TI recommends a series current limiting resistor to limit the power dissipation.

Unused push-pull outputs must be left floating, and never tied to a supply, or ground, or any another output.

The output protection consists of a ESD clamp between the output and V_- , and also between the output and V_+ , so the output must not exceed either supply rail.

6.4.2 Power-On Reset (POR)

The TLV90xx-Q1 has a internal Power-on-Reset (POR) circuit for known start-up or power-down conditions. While the power supply (V_S) is ramping up or ramping down, the POR circuitry is activated for up to 60 μ s (over temperature) after the minimum supply voltage threshold of V_{POR} is crossed (typically 1.25V), or immediately when the supply voltage drops below V_{POR} . During the POR period, the input conditions are ignored. When the supply voltage is equal to or greater than the minimum supply voltage, and after the delay period, the comparator output reflects the state of the differential input ("L1" option), or initially in a latched condition ("L2" option).

The input levels must be settled before the end of the POR period to prevent premature latching. Attention must be paid to the time constants of any filtering or RC components on the inputs (references, dividers, bypass capacitors, and so forth).

The open drain and push-pull output types have different POR and latch behaviors. The next section explains these differences.

6.4.2.1 TLV902xL-Q1 Open Drain Output POR Behavior

For the TLV902xL-Q1 open-drain output, the POR circuit keeps the output **high**, or high impedance ("HI-Z"), during the POR period (t_{on}).

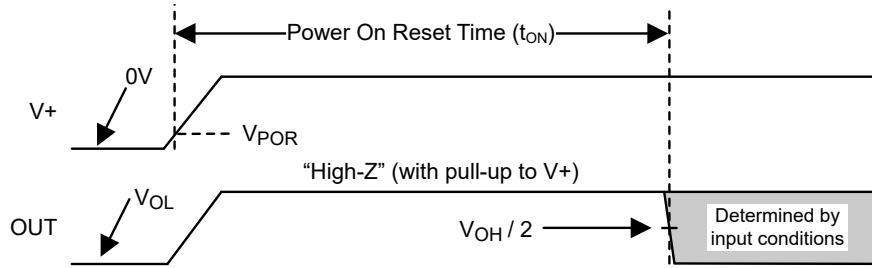

Figure 6-1. TLV902xL1-Q1 Power-On Reset Timing Diagram Example

The nature of an open collector output is that the output rises with the pull-up voltage during the POR period.

The TLV902xL2-Q1 option starts with the output **low** through POR then remains latched **low** post-POR until cleared.

6.4.2.2 TLV903xL-Q1 Push-Pull Output POR Behavior

For the TLV903xL1-Q1 push-pull output, the POR circuit keeps the output High-Z, neither sourcing or sinking current. The output can randomly "Float" between V+ and V- during the POR period (t_{ON}). A light pull-up (to V+) or pull-down (to V-) resistor can be used to prebias the output condition to prevent the output from floating.

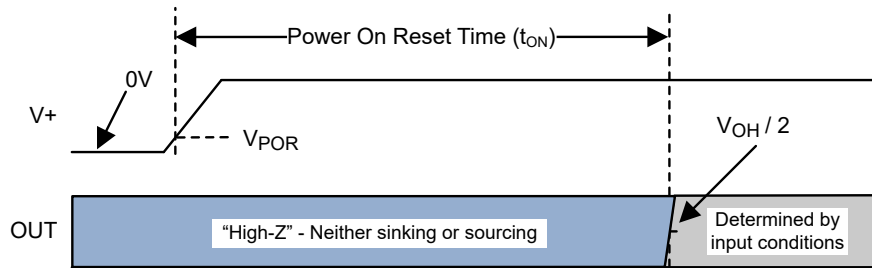

Figure 6-2. TLV903xL1-Q1 Power-On Reset Timing Diagram Example

The TLV903xL2-Q1 option starts with the output **high** (sourcing) through POR then latched **high** post-POR until cleared.

6.4.3 Output Latching

The TLV90xxL-Q1 has an output that latches upon the first input transition crossing through the input threshold after being armed. The output stays latched until the falling edge of the CLR pin.

The user has the option of the output being **un-latched at power-on** ("L1" option), or **latched at power-on** ("L2" option).

The latch behavior is different between the Open-Drain and Push-Pull output types. The behaviors are explained in the following sections.

6.4.3.1 "L1" and "L2" Power-On Options

The TLV90xxL-Q1 is available with two power-on options.

The "**L1**" option comes out of POR with the output in the **un-latched** state and is armed for the next latch event.

The "**L2**" option comes out of POR with the output held in the **latched** condition, and must be cleared by a high-to-low transition on the CLR pin to arm the comparator for the next latch event.

The Function Summary table below summarizes the behaviors.

Table 6-1. Function Summary

Device	Output Type	Output state during POR	Output State after POR	Armed output latches on:	Output Latch Condition
TLV902xL1-Q1	Open-Drain	High	Armed	H → L	Low
TLV902xL2-Q1	Open-Drain	Low	Latched Low	H → L	Low
TLV903xL1-Q1	Push-Pull	Hi-Z	Armed	L → H	High
TLV903xL2-Q1	Push-Pull	High	Latched High	L → H	High

See the following sections describing the latched state behavior for the different output types in detail.

6.4.3.2 TLV902xL1-Q1 Open-Drain Latch Behavior

The TLV902xL1-Q1 open-drain output is high during the **POR period**. After the POR period the latch is armed and **latches low** upon the first **high-to-low** output transition. The following is a summary of the latch operation.

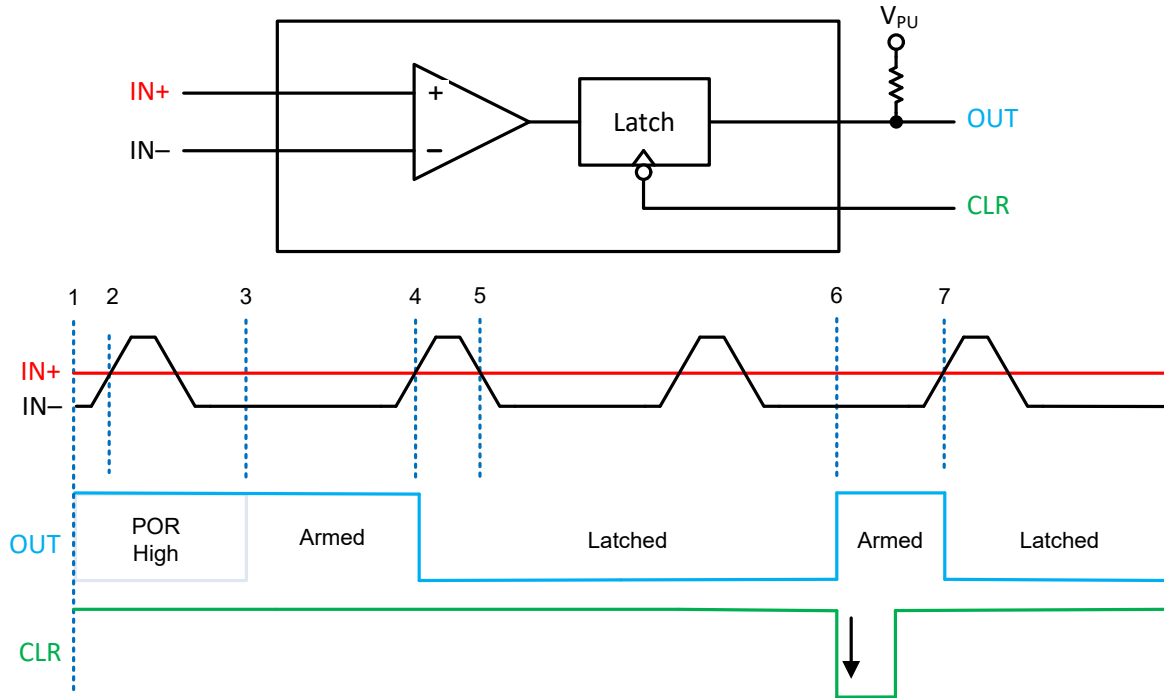

Figure 6-3. Open Drain Latch Timing Example (L1 option)

1. Output is high during the POR period at first power-up.
2. During POR period, input transition is ignored.
3. Following the POR period, comparator is armed and monitors inputs.
4. IN- now higher than IN+, setting output low and latching low.
5. IN+ greater than IN-, but output still remains low (latched).
6. CLR falling edge resets latch for next transition. IN+ > IN-, output remains high and armed for next input transition.
7. IN- > IN+, setting output low and latching again. Output remains latched even when IN+ > IN-.

6.4.3.3 TLV902xL2-Q1 Open-Drain Latch Behavior

The TLV902xL2-Q1 open-drain output latches **low** during the POR period. Following the POR period, the output is **latched low** and must be cleared with a **high-to-low** transition on the CLR pin. The following is a summary of the latch operation.

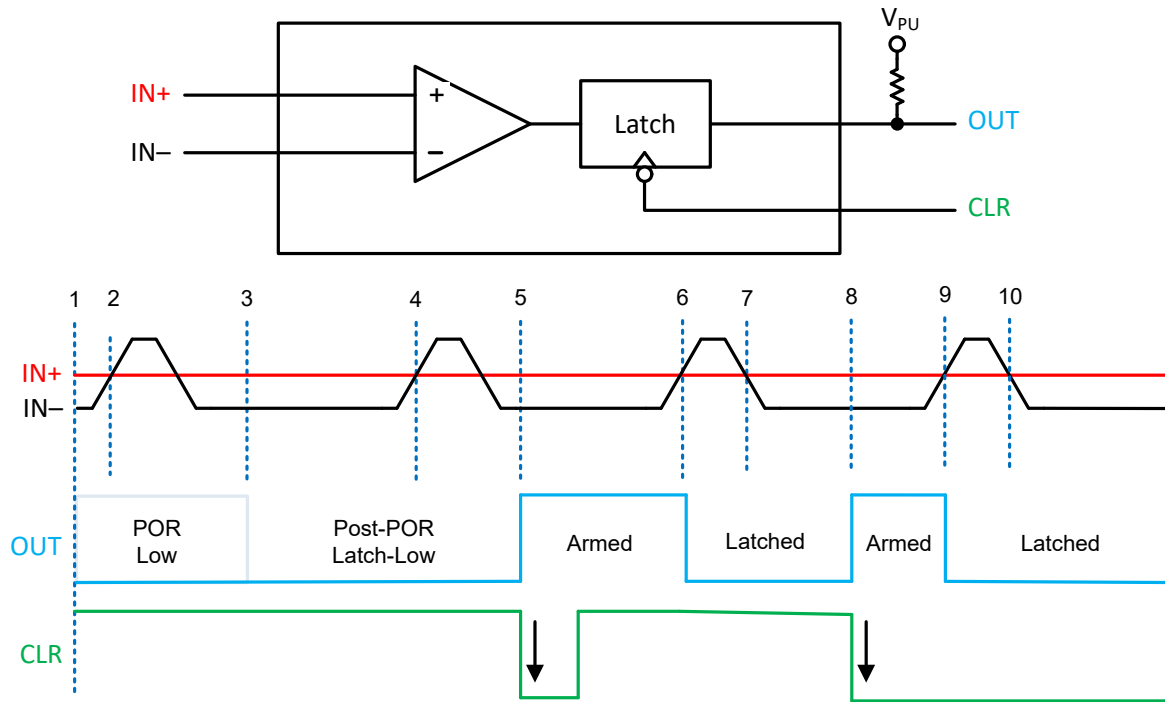

Figure 6-4. Open Drain Latch Timing Example (L2 option)

The following is a summary of the latch operation.

1. Output is low during the POR period following first power-on.
2. Input transition is ignored during POR period.
3. Following the POR period, the OUT stays latched low.
4. IN- passes IN+, but transition is ignored during latch.
5. CLR falling edge resets and arms latch awaiting next transition.
6. IN- > IN+, so OUT goes low and latches.
7. IN+ > IN-, but OUT remains latched low.
8. CLR falling edge resets and arms latch for next transition.
9. IN- crosses IN+, output goes low and latches again.
10. Output remains latched low even when IN+ > IN-.

6.4.3.4 TLV903xL1-Q1 Push-Pull Latch Behavior

The TLV903xL1-Q1 push-pull output is **High-Z** (neither sinking or sourcing current) during the **POR period**. Following the POR period, the latch is armed and **latches high** upon the first **low-to-high** output transition.

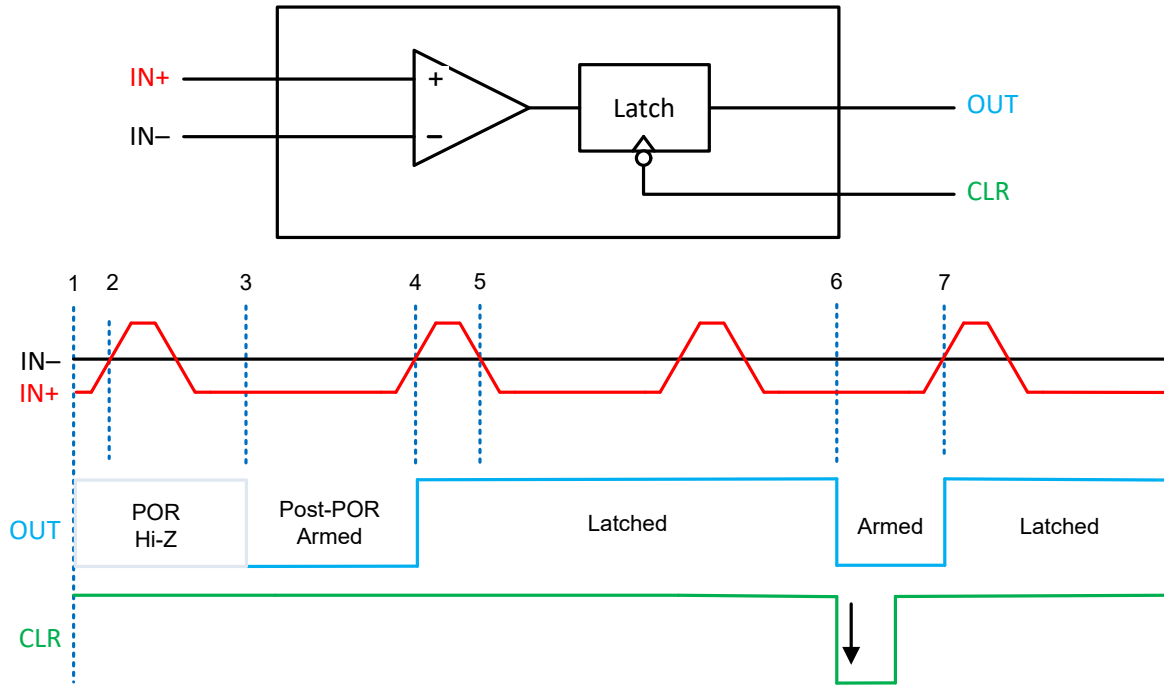

Figure 6-5. Push-Pull Latch Timing Example (L1 option)

The following is a summary of the latch operation.

1. Output is Hi-Z during the POR period at first power-up.
2. During POR period, input transition is ignored.
3. Following the POR period, comparator is armed and monitors inputs.
4. IN+ now higher than IN-, setting output high and latching high.
5. IN- greater than IN+, but output still remains high (latched).
6. CLR falling edge resets latch for next transition. IN- > IN+, output remains low and armed for next input transition.
7. IN+ > IN-, setting output high and latching again. Output remains latched even when IN- > IN+.

6.4.3.5 TLV903xL2-Q1 Push-Pull Latch Behavior

The TLV903xL2-Q1 push-pull output latches **high (sourcing current)** during the POR period. Following the POR period, the output is **latched high** and must be cleared by a high-to-low transition on the CLR pin.

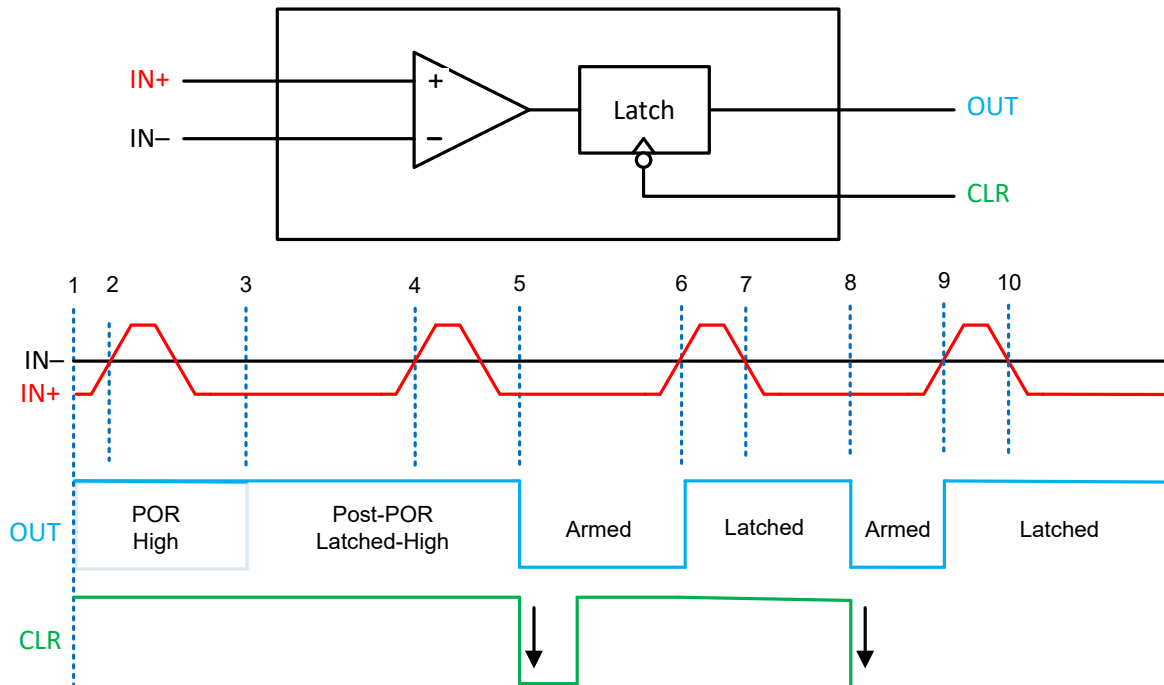

Figure 6-6. Push-Pull Latch Timing Example (L2 option)

The following is a summary of the latch operation.

1. Output is high during the POR period following first power-on.
2. Input transition is ignored during POR period.
3. Following the POR period, the OUT latches high.
4. IN+ passes IN-, but transition is ignored during latch.
5. CLR falling edge resets and arms latch awaiting next transition.
6. IN+ > IN-, so OUT goes high and latches.
7. IN- > IN+, but OUT remains latched high.
8. CLR falling edge resets and arms latch for next transition.
9. IN+ crosses IN-, output goes high and latches again.
10. Output remains latched high even when IN- > IN+.

6.4.3.6 Clear (CLR) Input

When CLR is high or low, and the comparator is not in a latched condition, the comparator is active ("armed") and responding to the input conditions, ready for the next qualifying condition to latch.

The CLR input only clears the output latch on the high-to-low (falling) edge of the CLR input. The comparator is then active (armed) after the clear until the next latch condition event.

Using the falling-edge to trigger the reset allows the CLR pin to be either a steady high or low, which prevents a hardware or software failure from locking-up the comparator and allows meeting safety-critical design requirements.

There can be a setup-time contention if the CLR pin is transitioning (falling) at the same time as the comparator output transitions. The output state is indeterminate during the CLR falling edge time. The recommendation is to make the CLR falling-edge as fast as possible to avoid this contention (<100ns fall time).

The CLR pin features a Failsafe, or "5V Compatible" input, accepting logic high levels up to 5V, independent of the comparator supply voltage. The logic high (VOH) threshold is 1.2V.

The CLR input also has a light 200nA active pull-down current to make sure that the CLR pin is low during start-up and the comparator is active. Even with this pull-down, floating the CLR input is not recommended.

6.4.4 Inputs

6.4.4.1 Rail to Rail Input

The TLV90xxL-Q1 input voltage range extends from 200mV below V_- to 200mV above V_+ . The differential input voltage (V_{ID}) can be any voltage within these limits. No phase-inversion of the comparator output occurs when the input pins exceed V_+ or V_- .

6.4.4.2 Fail-Safe Inputs

The TLV90xxL-Q1 inputs are fault tolerant up to 5.5V independent of V_S . Fault tolerant is defined as maintaining the same high input impedance when V_S is un-powered or within the recommended operating ranges.

The fault tolerant inputs can be any value between 0V and 5.5V, even while V_S is zero or ramping up or down. This feature avoids power sequencing issues as long as the input voltage range and supply voltage are within the maximum specified ranges. This is possible since the inputs are not clamped to V_+ and the input current maintains high impedance even when a higher voltage is applied to the inputs.

As long as one of the input pins remains within the valid input range, and the supply voltage is valid and not in POR, the output state is correct.

The following is a summary of input voltage excursions and the outcomes:

1. When both IN- and IN+ are within the specified input voltage range:
 - a. If IN- is higher than IN+ and the offset voltage, the output is low.
 - b. If IN- is lower than IN+ and the offset voltage, the output is high.
2. When IN- is higher than the specified input voltage range and IN+ is within the specified voltage range, the output is low.
3. When IN+ is higher than the specified input voltage range and IN- is within the specified input voltage range, the output is high.
4. When IN- and IN+ are both outside the specified input voltage range, the output is **indeterminate** (random). Do not operate in this region. The output can randomly flip.

Even with the fault tolerant feature, TI *strongly* recommends keeping the inputs within the specified input voltage range during normal system operation to maintain data sheet specifications. Operating outside the specified input range can cause changes in specifications such as propagation delay and input bias current, which can lead to unpredictable behavior.

6.4.4.3 Input Protection

The TLV90xxL-Q1 family incorporates internal ESD protection circuits on all pins. The inputs use a proprietary "snapback" type ESD clamp from each pin to V-. There is no "upper" ESD clamp to V+, which allows the input pins to exceed the supply voltage (V+). During an ESD event, the snapback diodes "short" and go low impedance to V- (like an SCR).

If the inputs are to be connected to a low impedance source, such as a power supply or buffered reference line, TI recommends adding a current-limiting resistor in series with the input to limit any transient currents if the clamps conduct due to transients. The current must be limited 10mA or less. This series resistance can be part of any resistive input dividers or networks.

The ESD diodes can not clamp on the upper voltages. The ESD clamps do not "hold" at a fixed maximum voltage like a Zener diode. If the inputs are connected to a source that can exceed 5.5V, then external clamping is required to prevent exceeding the maximum input voltage.

The input bias current is typically 5pA for input voltages between V+ and V-. Input bias current typically doubles for each 10°C temperature increase.

6.4.4.4 Internal Hysteresis

The TLV90xxL-Q1 does NOT have built-in hysteresis. The latching function negates the need for hysteresis as the output latches upon the first output transition. The reference level must be set to the desired threshold level, and the input signals well filtered to remove any noise or transients that can cause early triggering.

6.4.4.5 Unused Inputs

If a channel is not to be used, *do not* tie the inputs together. Due to the high equivalent bandwidth and low offset voltage, tying the inputs directly together can cause high frequency oscillations as the device triggers on the internal wideband noise. Instead, the inputs must be tied to any available voltage that resides within the specified input voltage range and provides a minimum of 50mV differential voltage. For example, one input can be grounded and the other input connected to a reference voltage, or even (V+).

7 Application and Implementation

Note

Information in the following applications sections is not part of the TI component specification, and TI does not warrant its accuracy or completeness. TI's customers are responsible for determining suitability of components for their purposes. Customers should validate and test their design implementation to confirm system functionality.

7.1 Application Information

7.1.1 Basic Comparator Definitions

7.1.1.1 Operation

The basic comparator compares the input voltage (V_{IN}) on one input to a reference voltage (V_{REF}) on the other input. In the [Figure 7-1](#) example below, if V_{IN} is less than V_{REF} , the output voltage (V_O) is logic low (V_{OL}). If V_{IN} is greater than V_{REF} , the output voltage (V_O) is at logic high (V_{OH}). [Table 7-1](#) summarizes the output conditions. The output logic can be inverted by simply swapping the input pins.

Table 7-1. Output Conditions

Inputs Condition	Output
$IN+ > IN-$	HIGH (V_{OH})
$IN+ = IN-$	Indeterminate
$IN+ < IN-$	LOW (V_{OL})

7.1.1.2 Propagation Delay

There is a delay between from when the input crosses the reference voltage and the output responds. This is called the Propagation Delay. Propagation delay can be different between high-to low and low-to-high input transitions. This is shown as t_{pLH} and t_{pHL} in [Figure 7-1](#) and is measured from the mid-point of the input to the midpoint of the output.

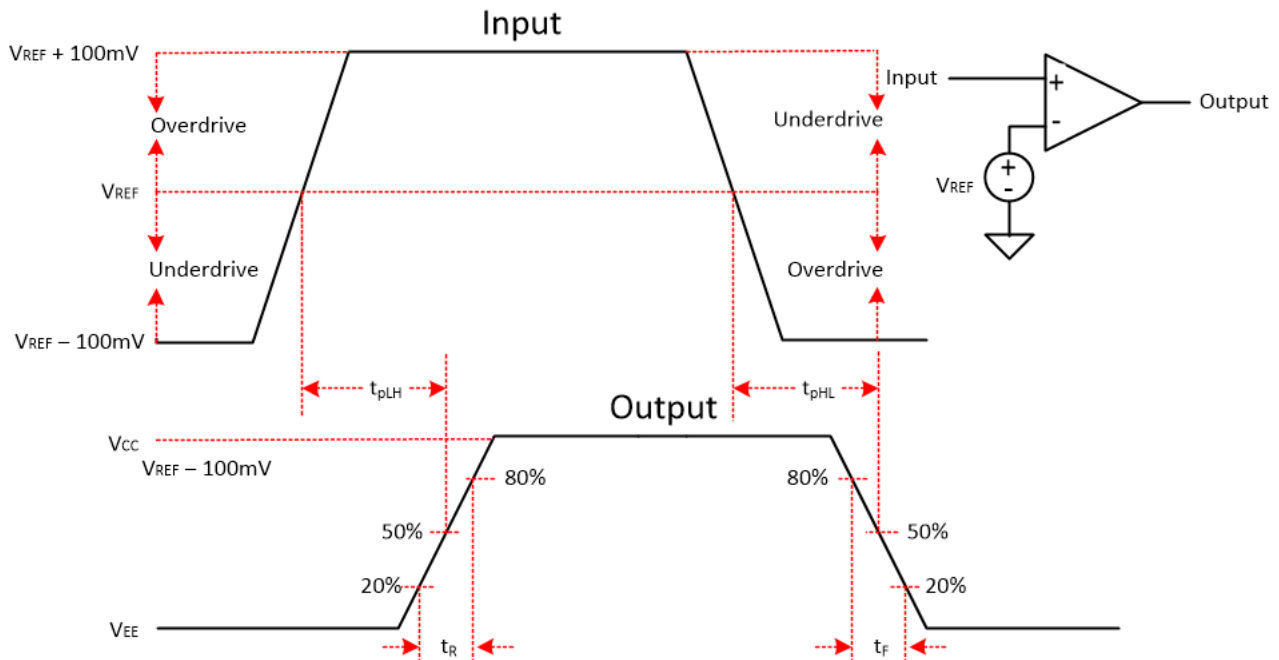

Figure 7-1. Comparator Timing Diagram

7.1.1.3 Overdrive Voltage

The overdrive voltage, V_{OD} , is the amount of input voltage beyond the reference voltage (and not the total input peak-to-peak voltage). The overdrive voltage is 100mV as shown in the [Figure 7-1](#) example. The overdrive voltage can influence the propagation delay (t_p). The smaller the overdrive voltage, the longer the propagation delay, particularly when $<100\text{mV}$. If the fastest speeds are desired, apply the highest amount of overdrive possible.

The risetime (t_r) and falltime (t_f) is the time from the 20% and 80% points of the output waveform.

7.2 Typical Applications

7.2.1 Window Comparator

Window comparators are commonly used to detect undervoltage and overvoltage conditions. [Figure 7-2](#) shows a simple window comparator circuit. Window comparators require open drain outputs (TLV902xL1-Q1) if the outputs are directly connected together.

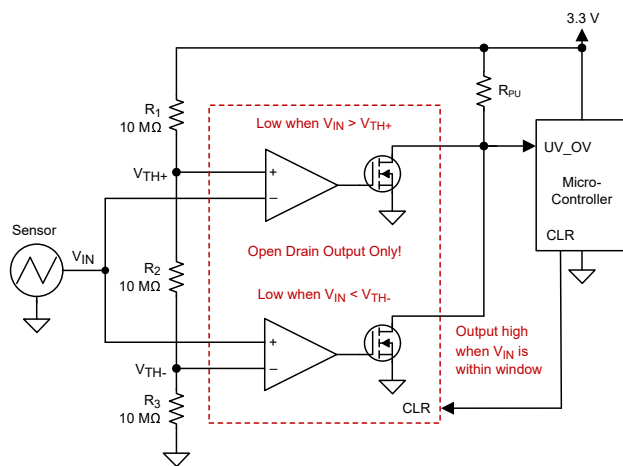

Figure 7-2. Window Comparator using TLV9022L1-Q1

7.2.1.1 Design Requirements

For this design, follow these design requirements:

- Latch (logic low output) when an input signal is less than 1.1V
- Latch (logic low output) when an input signal is greater than 2.2V
- Operate from a 3.3V power supply

7.2.1.2 Detailed Design Procedure

Configure the circuit as shown in [Figure 7-2](#). Make R1, R2 and R3 each 10MΩ resistors. These three resistors are used to create the positive and negative thresholds for the window comparator (V_{TH+} and V_{TH-}).

With each resistor being equal, V_{TH+} is 2.2V and V_{TH-} is 1.1V. Large resistor values such as 10MΩ are used to minimize power consumption. The resistor values can be recalculated to provide the desired trip point values.

The sensor output voltage is applied to the inverting and non-inverting inputs of the two comparators. Using two open-drain output comparators allows the two comparator outputs to be wire-ORed together.

The respective comparator outputs latches low when the sensor is less than 1.1V or greater than 2.2V. The respective comparator outputs are high when the sensor is in the range of 1.1V to 2.2V (within the "window"), as shown in [Figure 7-3](#).

The CLR pin must be toggled high to low to reset the output and arm the comparator.

7.2.1.3 Application Curve

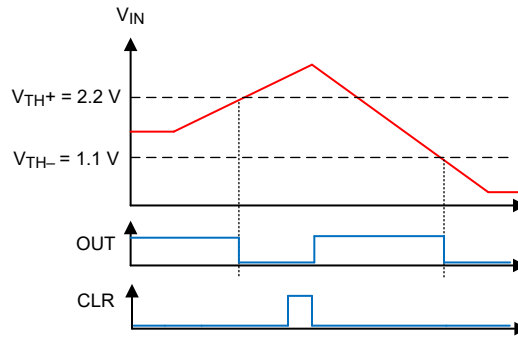

Figure 7-3. Window Comparator Results

For more information, please see [Window Comparator Circuit analog engineer's circuit](#).

7.3 Power Supply Recommendations

Due to the fast output edges, bypass capacitors are critical on the supply pin to prevent supply ringing and false triggers and oscillations. Bypass the supply directly at *each* device with a low ESR 0.1 μ F ceramic bypass capacitor directly between the (V+) pin and ground pins. Narrow peak currents are drawn during the output transition time, particularly for the push-pull output device. These narrow pulses can cause un-bypassed supply lines and poor grounds to ring, possibly causing variation that can eat into the input voltage range and create an inaccurate comparison or even oscillations.

The device can be powered from both "split" supplies ((V+) and (V-)), or "single" supplies ((V+) and GND), with GND applied to the (V-) pin. Input signals must stay within the recommended input range for either type. Note that with a "split" supply the output now swings "low" (V_{OL}) to (V-) potential and not GND.

7.4 Layout

7.4.1 Layout Guidelines

For accurate comparator applications, maintain a stable power supply with minimized noise and glitches. Output rise and fall times are in the tens of nanoseconds, and must be treated as high speed logic devices. The bypass capacitor must be as close to the supply pin as possible and connected to a solid ground plane, and preferably directly between the (V+) and GND pins.

Minimize coupling between outputs and inputs to prevent output oscillations. Do not run output and input traces in parallel unless there is a (V+) or GND trace between output to reduce coupling. When series resistance is added to inputs, place resistor close to the device. A low value (<100 Ω) resistor can also be added in series with the output to dampen any ringing or reflections on long, non-impedance controlled traces. For best edge shapes, controlled impedance traces with back-terminations must be used when routing long distances.

7.4.2 Layout Example

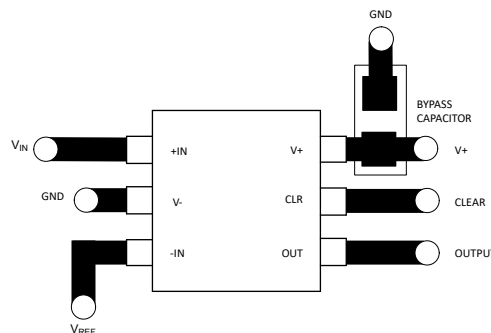

Figure 7-4. Single Layout Example

8 Device and Documentation Support

8.1 Documentation Support

8.1.1 Related Documentation

- Texas Instruments, [Analog Engineers Circuit Cookbook: Amplifiers \(see comparators section\) e-book](#)
- Texas Instruments, [A Quad of Independently Functioning Comparators](#) application note
- Texas Instruments, [Comparator With and Without Hysteresis Circuit](#) analog engineer's circuit
- Texas Instruments, [Comparator With Hysteresis](#) design guide
- Texas Instruments, [Inverting comparator with hysteresis circuit](#) application brief
- Texas Instruments, [Non-Inverting Comparator With Hysteresis Circuit](#) circuit design
- Texas Instruments, [Window Comparator Circuit](#) analog engineer's circuit
- Texas Instruments, [Window Comparator Reference Design](#) design guide

8.2 Receiving Notification of Documentation Updates

To receive notification of documentation updates, navigate to the device product folder on ti.com. Click on *Notifications* to register and receive a weekly digest of any product information that has changed. For change details, review the revision history included in any revised document.

8.3 Support Resources

[TI E2E™ support forums](#) are an engineer's go-to source for fast, verified answers and design help — straight from the experts. Search existing answers or ask your own question to get the quick design help you need.

Linked content is provided "AS IS" by the respective contributors. They do not constitute TI specifications and do not necessarily reflect TI's views; see TI's [Terms of Use](#).

8.4 Trademarks

TI E2E™ is a trademark of Texas Instruments.
All trademarks are the property of their respective owners.

8.5 Electrostatic Discharge Caution



This integrated circuit can be damaged by ESD. Texas Instruments recommends that all integrated circuits be handled with appropriate precautions. Failure to observe proper handling and installation procedures can cause damage.

ESD damage can range from subtle performance degradation to complete device failure. Precision integrated circuits may be more susceptible to damage because very small parametric changes could cause the device not to meet its published specifications.

8.6 Glossary

[TI Glossary](#) This glossary lists and explains terms, acronyms, and definitions.

9 Revision History

NOTE: Page numbers for previous revisions may differ from page numbers in the current version.

DATE	REVISION	NOTES
December 2025	*	Initial Release

10 Mechanical, Packaging, and Orderable Information

The following pages include mechanical, packaging, and orderable information. This information is the most current data available for the designated devices. This data is subject to change without notice and revision of this document. For browser-based versions of this data sheet, refer to the left-hand navigation.

PACKAGING INFORMATION

Orderable part number	Status (1)	Material type (2)	Package Pins	Package qty Carrier	RoHS (3)	Lead finish/ Ball material (4)	MSL rating/ Peak reflow (5)	Op temp (°C)	Part marking (6)
TLV9020L1QDCKRQ1	Active	Production	SC70 (DCK) 6	3000 LARGE T&R	-	SN	Level-1-260C-UNLIM	-40 to 125	3R9H
TLV9030L1QDCKRQ1	Active	Production	SC70 (DCK) 6	3000 LARGE T&R	Yes	SN	Level-1-260C-UNLIM	-40 to 125	3R8H

(1) **Status:** For more details on status, see our [product life cycle](#).

(2) **Material type:** When designated, preproduction parts are prototypes/experimental devices, and are not yet approved or released for full production. Testing and final process, including without limitation quality assurance, reliability performance testing, and/or process qualification, may not yet be complete, and this item is subject to further changes or possible discontinuation. If available for ordering, purchases will be subject to an additional waiver at checkout, and are intended for early internal evaluation purposes only. These items are sold without warranties of any kind.

(3) **RoHS values:** Yes, No, RoHS Exempt. See the [TI RoHS Statement](#) for additional information and value definition.

(4) **Lead finish/Ball material:** Parts may have multiple material finish options. Finish options are separated by a vertical ruled line. Lead finish/Ball material values may wrap to two lines if the finish value exceeds the maximum column width.

(5) **MSL rating/Peak reflow:** The moisture sensitivity level ratings and peak solder (reflow) temperatures. In the event that a part has multiple moisture sensitivity ratings, only the lowest level per JEDEC standards is shown. Refer to the shipping label for the actual reflow temperature that will be used to mount the part to the printed circuit board.

(6) **Part marking:** There may be an additional marking, which relates to the logo, the lot trace code information, or the environmental category of the part.

Multiple part markings will be inside parentheses. Only one part marking contained in parentheses and separated by a "~" will appear on a part. If a line is indented then it is a continuation of the previous line and the two combined represent the entire part marking for that device.

Important Information and Disclaimer:The information provided on this page represents TI's knowledge and belief as of the date that it is provided. TI bases its knowledge and belief on information provided by third parties, and makes no representation or warranty as to the accuracy of such information. Efforts are underway to better integrate information from third parties. TI has taken and continues to take reasonable steps to provide representative and accurate information but may not have conducted destructive testing or chemical analysis on incoming materials and chemicals. TI and TI suppliers consider certain information to be proprietary, and thus CAS numbers and other limited information may not be available for release.

In no event shall TI's liability arising out of such information exceed the total purchase price of the TI part(s) at issue in this document sold by TI to Customer on an annual basis.

OTHER QUALIFIED VERSIONS OF TLV9020L-Q1, TLV9030L-Q1 :

- Catalog : [TLV9020L](#), [TLV9030L](#)

NOTE: Qualified Version Definitions:

- Catalog - TI's standard catalog product

TAPE AND REEL INFORMATION

QUADRANT ASSIGNMENTS FOR PIN 1 ORIENTATION IN TAPE



*All dimensions are nominal

Device	Package Type	Package Drawing	Pins	SPQ	Reel Diameter (mm)	Reel Width W1 (mm)	A0 (mm)	B0 (mm)	K0 (mm)	P1 (mm)	W (mm)	Pin1 Quadrant
TLV9020L1QDCKRQ1	SC70	DCK	6	3000	180.0	8.4	2.3	2.55	1.2	4.0	8.0	Q3
TLV9030L1QDCKRQ1	SC70	DCK	6	3000	180.0	8.4	2.3	2.55	1.2	4.0	8.0	Q3

TAPE AND REEL BOX DIMENSIONS

*All dimensions are nominal

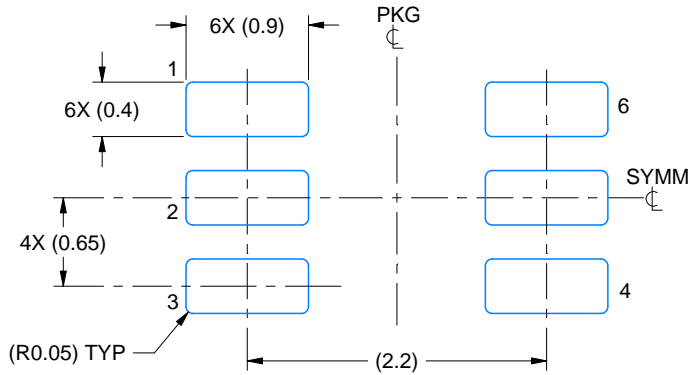
Device	Package Type	Package Drawing	Pins	SPQ	Length (mm)	Width (mm)	Height (mm)
TLV9020L1QDCKRQ1	SC70	DCK	6	3000	210.0	185.0	35.0
TLV9030L1QDCKRQ1	SC70	DCK	6	3000	210.0	185.0	35.0



LAND PATTERN EXAMPLE
EXPOSED METAL SHOWN
SCALE:18X

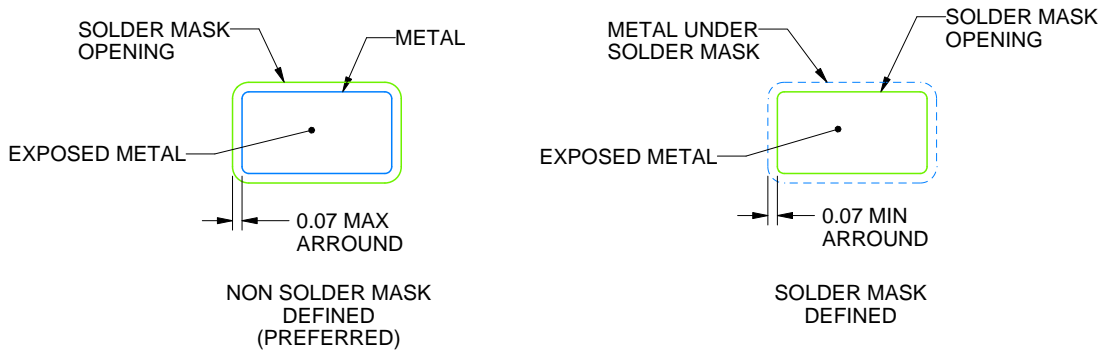

SOLDER MASK DETAILS

4214835/D 11/2024

NOTES: (continued)

- 5. Publication IPC-7351 may have alternate designs.
- 6. Solder mask tolerances between and around signal pads can vary based on board fabrication site.

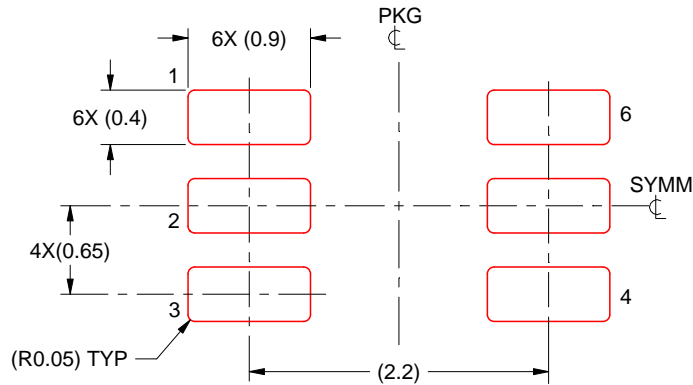

SOLDER PASTE EXAMPLE
BASED ON 0.125 THICK STENCIL
SCALE:18X

4214835/D 11/2024

NOTES: (continued)

7. Laser cutting apertures with trapezoidal walls and rounded corners may offer better paste release. IPC-7525 may have alternate design recommendations.
8. Board assembly site may have different recommendations for stencil design.

IMPORTANT NOTICE AND DISCLAIMER

TI PROVIDES TECHNICAL AND RELIABILITY DATA (INCLUDING DATASHEETS), DESIGN RESOURCES (INCLUDING REFERENCE DESIGNS), APPLICATION OR OTHER DESIGN ADVICE, WEB TOOLS, SAFETY INFORMATION, AND OTHER RESOURCES "AS IS" AND WITH ALL FAULTS, AND DISCLAIMS ALL WARRANTIES, EXPRESS AND IMPLIED, INCLUDING WITHOUT LIMITATION ANY IMPLIED WARRANTIES OF MERCHANTABILITY, FITNESS FOR A PARTICULAR PURPOSE OR NON-INFRINGEMENT OF THIRD PARTY INTELLECTUAL PROPERTY RIGHTS.

These resources are intended for skilled developers designing with TI products. You are solely responsible for (1) selecting the appropriate TI products for your application, (2) designing, validating and testing your application, and (3) ensuring your application meets applicable standards, and any other safety, security, regulatory or other requirements.

These resources are subject to change without notice. TI grants you permission to use these resources only for development of an application that uses the TI products described in the resource. Other reproduction and display of these resources is prohibited. No license is granted to any other TI intellectual property right or to any third party intellectual property right. TI disclaims responsibility for, and you fully indemnify TI and its representatives against any claims, damages, costs, losses, and liabilities arising out of your use of these resources.

TI's products are provided subject to [TI's Terms of Sale](#), [TI's General Quality Guidelines](#), or other applicable terms available either on ti.com or provided in conjunction with such TI products. TI's provision of these resources does not expand or otherwise alter TI's applicable warranties or warranty disclaimers for TI products. Unless TI explicitly designates a product as custom or customer-specified, TI products are standard, catalog, general purpose devices.

TI objects to and rejects any additional or different terms you may propose.

Copyright © 2026, Texas Instruments Incorporated

Last updated 10/2025