

# TMS320 SECOND GENERATION DIGITAL SIGNAL PROCESSORS

SPRS010B — MAY 1987 — REVISED NOVEMBER 1990

- 80-ns Instruction Cycle Time
- 544 Words of On-Chip Data RAM
- 4K Words of On-Chip Secure Program EPROM (TMS320E25)
- 4K Words of On-Chip Program ROM (TMS320C25)
- 128K Words of Data/Program Space
- 32-Bit ALU/Accumulator
- 16 × 16-Bit Multiplier With a 32-Bit Product
- Block Moves for Data/Program Management
- Repeat Instructions for Efficient Use of Program Space
- Serial Port for Direct Codec Interface
- Synchronization Input for Synchronous Multiprocessor Configurations
- Wait States for Communication to Slow Off-Chip Memories/Peripherals
- On-Chip Timer for Control Operations
- Single 5-V Supply
- Packaging: 68-Pin PGA, PLCC, and CER-QUAD
- 68-to-28 Pin Conversion Adapter Socket for EPROM Programming
- Commercial and Military Versions Available
- NMOS Technology:
  - TMS32020 ..... 200-ns cycle time
- CMOS Technology:
  - TMS320C25 ..... 100-ns cycle time
  - TMS320E25 ..... 100-ns cycle time
  - TMS320C25-50 ..... 80-ns cycle time

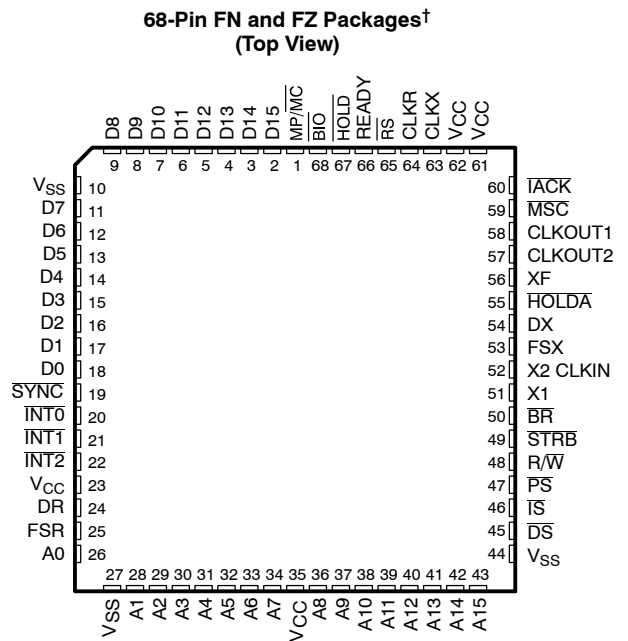
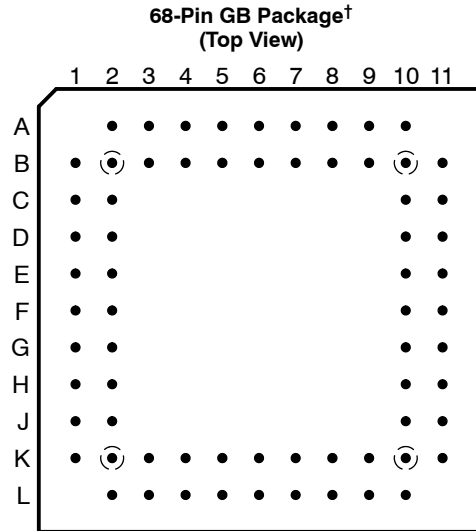

ADVANCE INFORMATION

## description

This data sheet provides complete design documentation for the second-generation devices of the TMS320 family. This facilitates the selection of the devices best suited for user applications by providing all specifications and special features for each TMS320 member. This data sheet is divided into four major sections: architecture, electrical specifications (NMOS and CMOS), timing diagrams, and mechanical data. In each of these sections, generic information is presented first, followed by specific device information. An index is provided for quick reference to specific information about a device.

ADVANCE INFORMATION concerns new products in the sampling or preproduction phase of development. Characteristic data and other specifications are subject to change without notice.



POST OFFICE BOX 1443 • HOUSTON, TEXAS 77001

Copyright © 1991, Texas Instruments Incorporated

# TMS320 SECOND GENERATION DIGITAL SIGNAL PROCESSORS

SPRS010B — MAY 1987 — REVISED NOVEMBER 1990

## PGA AND PLCC/CER-QUAD PIN ASSIGNMENTS

FUNCTION	PIN	FUNCTION	PIN	FUNCTION	PIN	FUNCTION	PIN	FUNCTION	PIN	FUNCTION	PIN
A0	K1/26	A12	K8/40	D2	E1/16	D14	A5/3	INT $\bar{2}$	H1/22	V <sub>CC</sub>	H2/23
A1	K2/28	A13	L9/41	D3	D2/15	D15	B6/2	$\bar{I\bar{S}}$	J11/46	V <sub>CC</sub>	L6/35
A2	L3/29	A14	K9/42	D4	D1/14	DR	J1/24	MP/ $\bar{M\bar{C}}$ <sup>†</sup>	A6/1	V <sub>SS</sub>	B1/10
A3	K3/30	A15	L10/43	D5	C2/13	$\bar{D\bar{S}}$	K10/45	$\bar{M\bar{S}\bar{C}}$	C10/59	V <sub>SS</sub>	K11/44
A4	L4/31	$\bar{B\bar{I}\bar{O}}$	B7/68	D6	C1/12	DX	E11/54	$\bar{P\bar{S}}$	J10/47	V <sub>SS</sub>	L2/27
A5	K4/32	$\bar{B\bar{R}}$	G11/50	D7	B2/11	FSR	J2/25	READY	B8/66	XF	D11/56
A6	L5/33	CLKOUT1	C11/58	D8	A2/9	FSX	F10/53	$\bar{R\bar{S}}$	A8/65	X1	G10/51
A7	K5/34	CLKOUT2	D10/57	D9	B3/8	HOLD	A7/67	R/ $\bar{W}$	H11/48	X2/CLKIN	F11/52
A8	K6/36	CLKR	B9/64	D10	A3/7	$\bar{H\bar{O}\bar{L}\bar{D}\bar{A}}$	E10/55	$\bar{S}\bar{T}\bar{R}\bar{B}$	H10/49		
A9	L7/37	CLKX	A9/63	D11	B4/6	$\bar{I\bar{A}\bar{C}\bar{K}}$	B11/60	$\bar{S}\bar{Y}\bar{N}\bar{C}$	F2/19		
A10	K7/38	D0	F1/18	D12	A4/5	INT $\bar{0}$	G1/20	V <sub>CC</sub>	A10/61		
A11	L8/39	D1	E2/17	D13	B5/4	INT $\bar{1}$	G2/21	V <sub>CC</sub>	B10/62		

<sup>†</sup> On the TMS32020, MP/ $\bar{M\bar{C}}$  must be connected to V<sub>CC</sub>.

SIGNALS	I/O/Z <sup>‡</sup>	DEFINITION
V <sub>CC</sub>	I	5-V supply pins
V <sub>SS</sub>	I	Ground pins
X1	O	Output from internal oscillator for crystal
X2/CLKIN	I	Input to internal oscillator from crystal or external clock
CLKOUT1	O	Master clock output (crystal or CLKIN frequency/4)
CLKOUT2	O	A second clock output signal
D15-D0	I/O/Z	16-bit data bus D15 (MSB) through D0 (LSB). Multiplexed between program, data, and I/O spaces.
A15-A0	O/Z	16-bit address bus A15 (MSB) through A0 (LSB)
$\bar{P\bar{S}}$ , $\bar{D\bar{S}}$ , $\bar{I\bar{S}}$	O/Z	Program, data, and I/O space select signals
R/ $\bar{W}$	O/Z	Read/write signal
$\bar{S}\bar{T}\bar{R}\bar{B}$	O/Z	Strobe signal
$\bar{R\bar{S}}$	I	Reset input
INT $\bar{2}$ -INT $\bar{0}$	I	External user interrupt inputs
MP/ $\bar{M\bar{C}}$	I	Microprocessor/microcomputer mode select pin
$\bar{M\bar{S}\bar{C}}$	O	Microstate complete signal
$\bar{I\bar{A}\bar{C}\bar{K}}$	O	Interrupt acknowledge signal
READY	I	Data ready input. Asserted by external logic when using slower devices to indicate that the current bus transaction is complete.
$\bar{B\bar{R}}$	O	Bus request signal. Asserted when the TMS320C2x requires access to an external global data memory space.
XF	O	External flag output (latched software-programmable signal)
HOLD	I	Hold input. When asserted, TMS320C2x goes into an idle mode and places the data, address, and control lines in the high impedance state.
$\bar{H\bar{O}\bar{L}\bar{D}\bar{A}}$	O	Hold acknowledge signal
$\bar{S}\bar{Y}\bar{N}\bar{C}$	I	Synchronization input
$\bar{B\bar{I}\bar{O}}$	I	Branch control input. Polled by BIOZ instruction.
DR	I	Serial data receive input
CLKR	I	Clock for receive input for serial port
FSR	I	Frame synchronization pulse for receive input
DX	O/Z	Serial data transmit output
CLKX	I	Clock for transmit output for serial port
FSX	I/O/Z	Frame synchronization pulse for transmit. Configuration as either an input or an output.

<sup>‡</sup> I/O/Z denotes input/output/high-impedance state.



## description

The TMS320 family of 16/32-bit single-chip digital signal processors combines the flexibility of a high-speed controller with the numerical capability of an array processor, thereby offering an inexpensive alternative to multichip bit-slice processors. The highly paralleled architecture and efficient instruction set provide speed and flexibility to produce a MOS microprocessor family that is capable of executing more than 12.5 MIPS (million instructions per section). The TMS320 family optimizes speed by implementing functions in hardware that other processors implement through microcode or software. This hardware-intensive approach provides the design engineer with processing power previously unavailable on a single chip.

The TMS320 family consists of three generations of digital signal processors. The first generation contains the TMS32010 and its spinoffs. The second generation includes the TMS32020, TMS320C25, and TMS320E25, which are described in this data sheet. The TMS320C30 is a floating-point DSP device designed for even higher performance. Many features are common among the TMS320 processors. Specific features are added in each processor to provide different cost/performance tradeoffs. Software compatibility is maintained throughout the family to protect the user's investment in architecture. Each processor has software and hardware tools to facilitate rapid design.

## introduction

The TMS32010, the first NMOS digital signal processor in the TMS320 family, was introduced in 1983. Its powerful instruction set, inherent flexibility, high-speed number-crunching capabilities, and innovative architecture have made this high-performance, cost-effective processor the ideal solution to many telecommunications, computer, commercial, industrial, and military applications. Since that time, the TMS320C10, a low-power CMOS version of the industry-standard TMS32010, and other spinoff devices have been added to the first generation of the TMS320 family.

The second generation of the TMS320 family (referred to as TMS320C2x) includes four members, the TMS32020, TMS320C25, TMS320C25-50, and TMS320E25. The architecture of these devices is based upon that of the TMS32010.

The **TMS32020**, processed in NMOS technology, is source-code compatible with the TMS32010 and in many applications is capable of two times the throughput of the first-generation devices. Its enhanced instruction set (109 instructions), large on-chip data memory (544 words), large memory spaces, on-chip serial port, and hardware timer make the TMS32020 a powerful addition to the TMS320 family.

The **TMS320C25** is the second member of the TMS320 second generation. It is processed in CMOS technology, is capable of an instruction cycle time of 100 ns, and is pin-for-pin and object-code compatible with the TMS32020. The TMS320C25's enhanced feature set greatly increases the functionality of the device over the TMS32020. Enhancements included 24 additional instructions (133 total), eight auxiliary registers, an eight-level hardware stack, 4K words of on-chip program ROM, a bit-reversed indexed-addressing mode, and the low-power dissipation inherent to the CMOS process. An extended-temperature range version (TMS320C25GBA) is also available.

The **TMS320C25-50** is a high-speed version of the TMS320C25. It is capable of an instruction cycle time of less than 80 ns. It is architecturally identical to the original 40-MHz version of the TMS320C25 and, thus, is pin-for-pin and object-code compatible with the TMS320C25.

The **TMS320E25** is identical to the TMS320C25, with the exception that the on-chip 4K-word program ROM is replaced with a 4K-word on-chip program EPROM. On-chip EPROM allows realtime code development and modification for immediate evaluation of system performance.

# TMS320 SECOND GENERATION DIGITAL SIGNAL PROCESSORS

SPRS010B — MAY 1987 — REVISED NOVEMBER 1990

## Key Features: TMS32020

- 200-ns Instruction Cycle Time
- 544 Words of On-Chip Data RAM
- 128K Words of Total Data/Program Memory Space
- Wait States for Communication to Slower Off-Chip Memories
- Source Code Compatible With the TMS320C1x
- Single-Cycle Multiply/Accumulate Instructions
- Repeat Instructions
- Global Data Memory Interface
- Block Moves for Data/Program Management
- Five Auxiliary Registers With Dedicated Arithmetic Unit
- Serial Port for Multiprocessing or Interfacing to Codecs, Serial Analog-to-Digital Converters, etc.

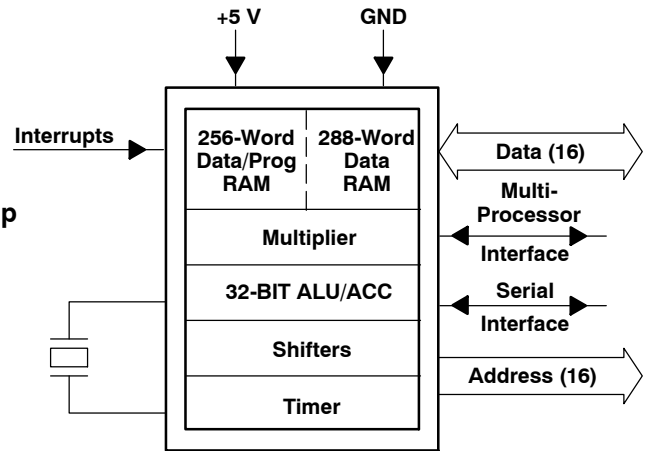

- On-Chip Clock Generator
- Single 5-V Supply
- NMOS Technology
- 68-Pin Grid Array (PGA) Package

## Key Features: TMS320C25, TMS320C25-50, TMS320E25

- 80-ns Instruction Cycle Time (TMS320C25-50)
- 100-ns Instruction Cycle Time (TMS320C25)
- 4K Words of On-Chip Secure Program EPROM (TMS320E25)
- 4K Words of On-Chip Program ROM (TMS320C25)
- 544 Words of On-Chip RAM
- 128K Words of Total Program/Data Memory Space
- Wait States for Communications to Slower Off-Chip Memories
- Object-Code Compatible With the TMS32020
- Source-Code Compatible With TMS320C1x
- 24 Additional Instructions to Support Adaptive Filtering, FFTs, and Extended-Precision Arithmetic
- Block Moves for Data/Program Management
- Single-Cycle Multiply/Accumulate Instructions
- Eight Auxiliary Registers With Dedicated Arithmetic Unit
- Bit-Reversed Indexed-Addressing Mode for Radix-2 FFTS
- Double-Buffered Serial Port

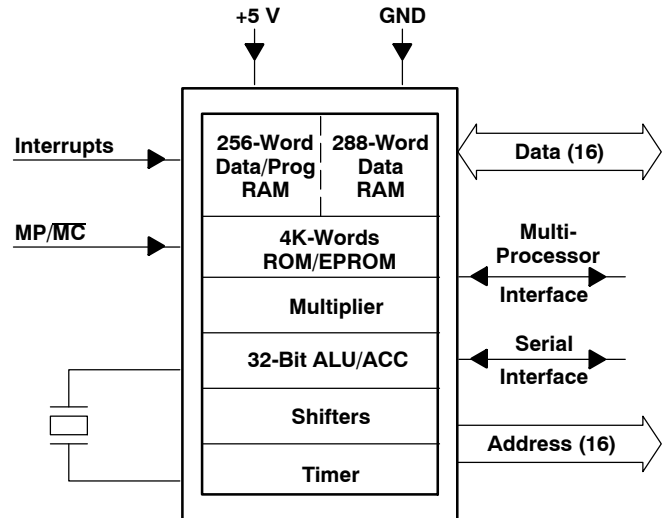

- On-Chip Clock Generator
- Single 5-V Supply
- Internal Security Mechanism (TMS320E25)
- 68-to-28 Pin Conversion Adapter Socket
- CMOS Technology
- 68-Pin Grid Array (PGA) Package (TMS320C25)
- 68-Lead Plastic Leaded Chip Carrier (PLCC) Package (TMS320C25, TMS320C25-50)
- 68-Lead CER-QUAD Package (TMS320E25)

Table 1 provides an overview of the second-generation TMS320 processors with comparisons of memory, I/O, cycle timing, power, package type, technology, and military support. For specific availability, contact the nearest TI Field Sales Office.

**Table 1. TMS320 Second-Generation Device Overview**

DEVICE	MEMORY				I/O†			TIMER	CYCLE TIME (ns)	TYP POWER (mW)	PACKAGE TYPE		
	ON-CHIP		OFF-CHIP		SER	PAR	DMA				PGA	PLCC	CER-QUAD
	RAM	ROM/EPROM	PROG	DATA									
TMS32020‡ (NMOS)	544	—	64K	64K	YES	16 × 16	YES	YES	200	1250	68	—	—
TMS320C25‡ (CMOS)	544	4K	64K	64K	YES	16 × 16	CON	YES	100	500	68	68	—
TMS320C25-50§ (CMOS)	544	4K	64K	64K	YES	16 × 16	CON	YES	80	500	—	68	—
TMS320E25§ (CMOS)	544	4K	64K	64K	YES	16 × 16	CON	YES	100	500	—	—	68

† SER = serial; PAR = parallel; DMA = direct memory access; CON = concurrent DMA.

‡ Military version available; contact nearest TI Field Sales Office for availability.

§ Military version planned; contact nearest TI Field Sales Office for details.

## architecture

The TMS320 family utilizes a modified Harvard architecture for speed and flexibility. In a strict Harvard architecture, program and data memory lie in two separate spaces, permitting a full overlap of instruction fetch and execution. The TMS320 family's modification of the Harvard architecture allows transfers between program and data spaces, thereby increasing the flexibility of the device. This modification permits coefficients stored in program memory to be read into the RAM, eliminating the need for a separate coefficient ROM. It also makes available immediate instructions and subroutines based on computed values.

Increased throughput on the TMS320C2x devices for many DSP applications is accomplished by means of single-cycle multiply/accumulate instructions with a data move option, up to eight auxiliary registers with a dedicated arithmetic unit, and faster I/O necessary for data-intensive signal processing.

The architectural design of the TMS320C2x emphasizes overall speed, communication, and flexibility in processor configuration. Control signals and instructions provide floating-point support, block-memory transfers, communication to slower off-chip devices, and multiprocessing implementations.

### 32-bit ALU/accumulator

The 32-bit Arithmetic Logic Unit (ALU) and accumulator perform a wide range of arithmetic and logical instructions, the majority of which execute in a single clock cycle. The ALU executes a variety of branch instructions dependent on the status of the ALU or a single bit in a word. These instructions provide the following capabilities:

- Branch to an address specified by the accumulator
- Normalize fixed-point numbers contained in the accumulator
- Test a specified bit of a word in data memory

One input to the ALU is always provided from the accumulator, and the other input may be provided from the Product Register (PR) of the multiplier or the input scaling shifter which has fetched data from the RAM on the data bus. After the ALU has performed the arithmetic or logical operations, the result is stored in the accumulator.

The 32-bit accumulator is split into two 16-bit segments for storage in data memory. Additional shifters at the output of the accumulator perform shifts while the data is being transferred to the data bus for storage. The contents of the accumulator remain unchanged.

# TMS320 SECOND GENERATION DIGITAL SIGNAL PROCESSORS

SPRS010B — MAY 1987 — REVISED NOVEMBER 1990

## functional block diagram (TMS320C2x)

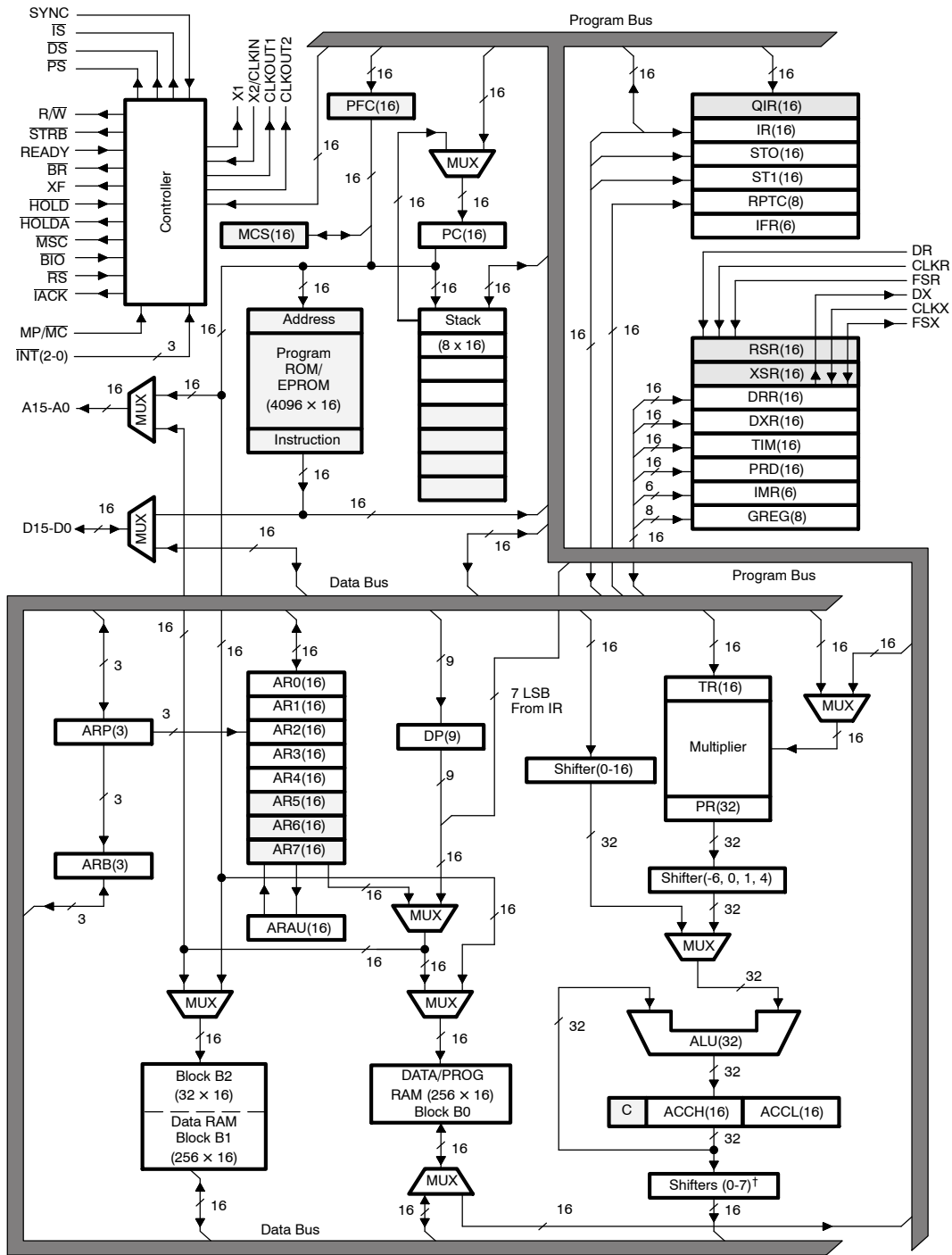

**LEGEND:**

- |   |                                  |   |
|---|----------------------------------|---|
| ACCH = Accumulator high                   | IFR = Interrupt flag register    | PC = Program counter                      |
| ACCL = Accumulator low                    | IMR = Interrupt mask register    | PFC = Prefetch counter                    |
| ALU = Arithmetic logic unit               | IR = Instruction register        | RPTC = Repeat instruction counter         |
| ARAU = Auxiliary register arithmetic unit | MCS = Microcall stack            | GREG = Global memory allocation register  |
| ARB = Auxiliary register pointer buffer   | QIR = Queue instruction register | RSR = Serial port receive shift register  |
| ARP = Auxiliary register pointer          | PR = Product register            | XSR = Serial port transmit shift register |
| DP = Data memory page pointer             | PRD = Period register for timer  | AR0-AR7 = Auxiliary registers             |
| DRR = Serial port data receive register   | TIM = Timer                      | ST0, ST1 = Status registers               |
| DXR = Serial port data transmit register  | TR = Temporary register          | C = Carry bit                             |

**scaling shifter**

The TMS320C2x scaling shifter has 16-bit input connected to the data bus and a 32-bit output connected to the ALU. The scaling shifter produces a left shift of 0 to 16 bits on the input data, as programmed in the instruction. The LSBs of the output are filled with zeroes, and the MSBs may be either filled with zeroes or sign-extended, depending upon the status programmed into the SXM (sign-extension mode) bit of status register ST1.

**16 × 16-bit parallel multiplier**

The 16 × 16-bit hardware multiplier is capable of computing a signed or unsigned 32-bit product in a single machine cycle. The multiplier has the following two associated registers.

- A 16-bit Temporary Register (TR) that holds one of the operands for the multiplier, and
- A 32-bit Product Register (PR) that holds the product.

Incorporated into the instruction set are single-cycle multiply/accumulate instructions that allow both operands to be processed simultaneously. The data for these operations may reside anywhere in internal or external memory, and can be transferred to the multiplier each cycle via the program and data buses.

Four product shift modes are available at the Product Register (PR) output that are useful when performing multiply/accumulate operations, fractional arithmetic, or justifying fractional products.

**timer**

The TMS320C2x provides a memory-mapped 16-bit timer for control operations. The on-chip timer (TIM) register is a down counter that is continuously clocked by CLKOUT1 on the TMS320C25. The timer is clocked by CLKOUT1/4 on the TMS32020. A timer interrupt (TINT) is generated every time the timer decrements to zero. The timer is reloaded with the value contained in the period (PRD) register within the next cycle after it reaches zero so that interrupts may be programmed to occur at regular intervals of  $PRD + 1$  cycles of CLKOUT 1 on the TMS320C25 or  $4 \times PRD \times CLKOUT 1$  cycles on the TMS32020.

**memory control**

The TMS320C2x provides a total of 544 16-bit words of on-chip data RAM, divided into three separate blocks (B0, B1, and B2). Of the 544 words, 288 words (blocks B1 and B2) are always data memory, and 256 words (block B0) are programmable as either data or program memory. A data memory size of 544 words allows the TMS320C2x to handle a data array of 512 words (256 words if on-chip RAM is used for program memory), while still leaving 32 locations for intermediate storage. When using block B0 as program memory, instructions can be downloaded from external program memory into on-chip RAM and then executed.

When using on-chip program RAM, ROM, EPROM, or high-speed external program memory, the TMS320C2x runs at full speed without wait states. However, the READY line can be used to interface the TMS320C2x to slower, less-expensive external memory. Downloading programs from slow off-chip memory to on-chip program RAM speeds processing while cutting system costs.

The TMS320C2x provides three separate address spaces for program memory, data memory, and I/O. The on-chip memory is mapped into either the 64K-word data memory or program memory space, depending upon the memory configuration (see Figure 1). The CNFD (configure block B0 as data memory) and CNFP (configure block B0 as program memory) instructions allow dynamic configuration of the memory maps through software. Regardless of the configuration, the user may still execute from external program memory.

The TMS320C2x has six registers that are mapped into the data memory space: a serial port data receive register, serial port data transmit register, timer register, period register, interrupt mask register, and global memory allocation register.

# TMS320 SECOND GENERATION DIGITAL SIGNAL PROCESSORS

SPRS010B — MAY 1987 — REVISED NOVEMBER 1990

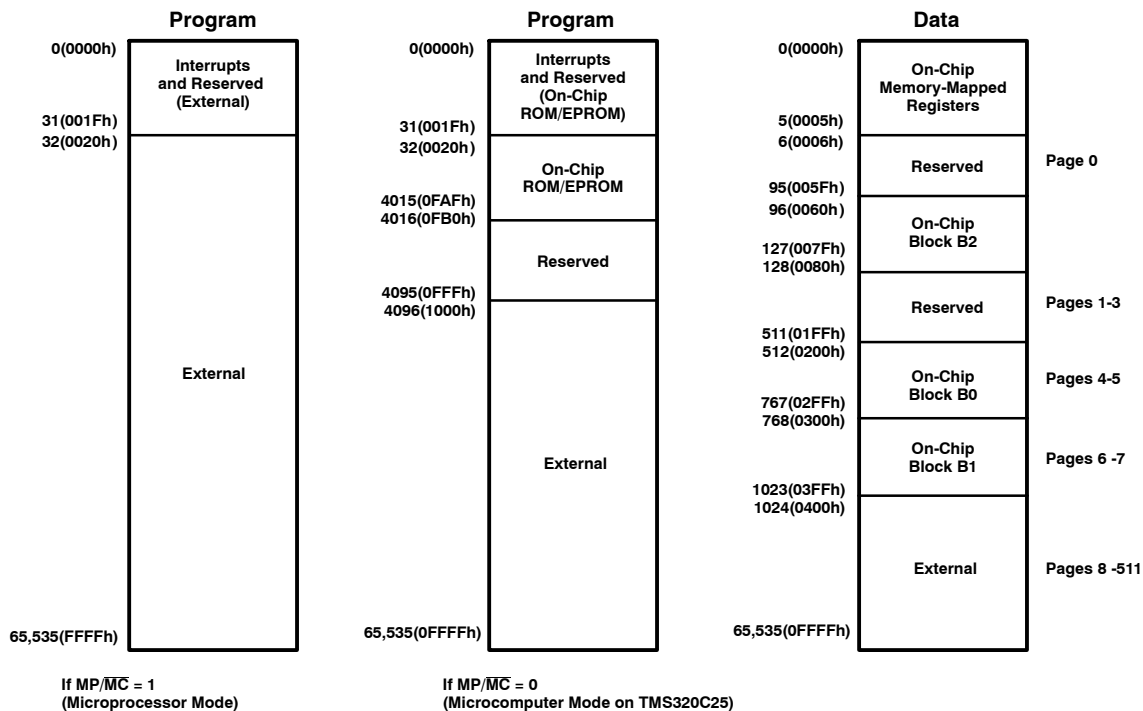

(a) Memory Maps After a CNFD Instruction

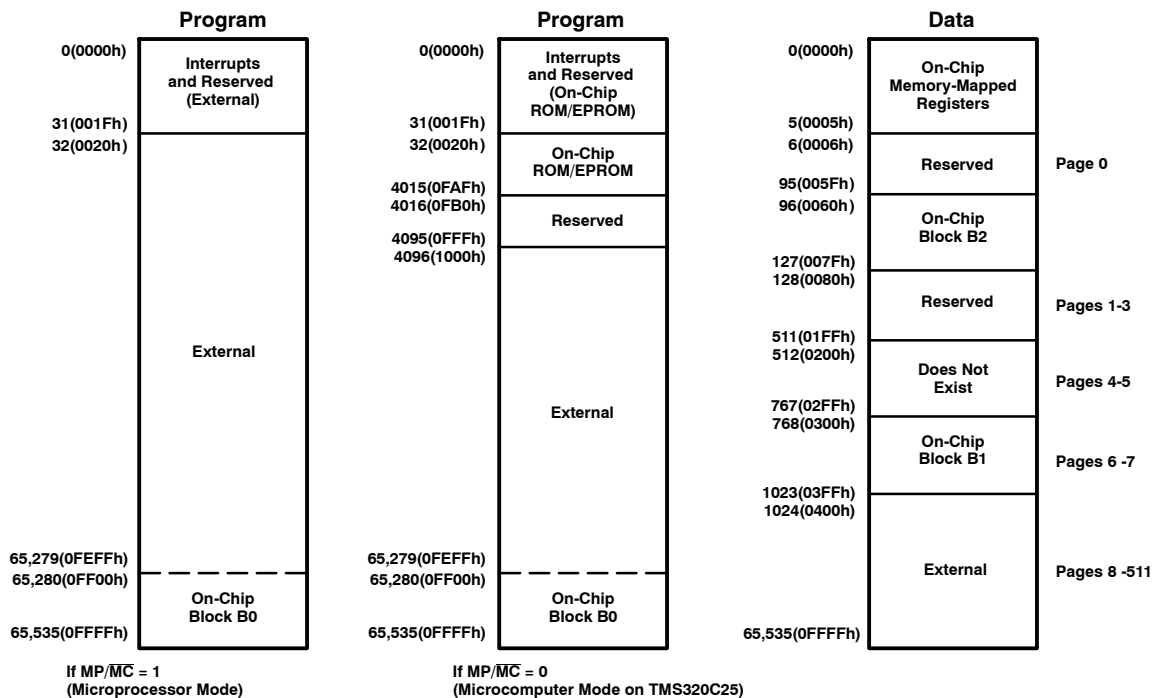

(b) Memory Maps After a CNFP Instruction

Figure 1. Memory Maps



## interrupts and subroutines

The TMS320C2x has three external maskable user interrupts  $\overline{\text{INT2}}$ - $\overline{\text{INT0}}$ , available for external devices that interrupt the processor. Internal interrupts are generated by the serial port (RINT and XINT), by the timer (TINT), and by the software interrupt (TRAP) instruction. Interrupts are prioritized with reset ( $\overline{\text{RS}}$ ) having the highest priority and the serial port transmit interrupt (XINT) having the lowest priority. All interrupt locations are on two-word boundaries so that branch instructions can be accommodated in those locations if desired.

A built-in mechanism protects multicycle instructions from interrupts. If an interrupt occurs during a multicycle instruction, the interrupt is not processed until the instruction is completed. This mechanism applies to instructions that are repeated and to instructions that become multicycle due to the READY signal.

## external interface

The TMS320C2x supports a wide range of system interfacing requirements. Program, data, and I/O address spaces provide interface to memory and I/O, thus maximizing system throughput. I/O design is simplified by having I/O treated the same way as memory. I/O devices are mapped into the I/O address space using the processor's external address and data buses in the same manner as memory-mapped devices. Interface to memory and I/O devices of varying speeds is accomplished by using the READY line. When transactions are made with slower devices, the TMS320C2x processor waits until the other device completes its function and signals the processor via the READY line. Then, the TMS320C2x continues execution.

A full-duplex serial port provides communication with serial devices, such as codecs, serial A/D converters, and other serial systems. The interface signals are compatible with codecs and many other serial devices with a minimum of external hardware. The serial port may also be used for intercommunication between processors in multiprocessing applications.

The serial port has two memory-mapped registers: the data transmit register (DXR) and the data receive register (DRR). Both registers operate in either the byte mode or 16-bit word mode, and may be accessed in the same manner as any other data memory location. Each register has an external clock, a framing synchronization pulse, and associated shift registers. One method of multiprocessing may be implemented by programming one device to transmit while the others are in the receive mode. The serial port on the TMS320C25 is double-buffered and fully static.

## multiprocessing

The flexibility of the TMS320C2x allows configurations to satisfy a wide range of system requirements and can be used as follows:

- A standalone processor
- A multiprocessor with devices in parallel
- A slave/host multiprocessor with global memory space
- A peripheral processor interfaced via processor-controlled signals to another device.

For multiprocessing applications, the TMS320C2x has the capability of allocating global data memory space and communicating with that space via the  $\overline{\text{BR}}$  (bus request) and READY control signals. Global memory is data memory shared by more than one processor. Global data memory access must be arbitrated. The 8-bit memory-mapped GREG (global memory allocation register) specifies part of the TMS320C2x's data memory as global external memory. The contents of the register determine the size of the global memory space. If the current instruction addresses an operand within that space,  $\overline{\text{BR}}$  is asserted to request control of the bus. The length of the memory cycle is controlled by the READY line.

The TMS320C2x supports DMA (direct memory access) to its external program/data memory using the  $\overline{\text{HOLD}}$  and  $\overline{\text{HOLDA}}$  signals. Another processor can take complete control of the TMS320C2x's external memory by asserting  $\overline{\text{HOLD}}$  low. This causes the TMS320C2x to place its address data and control lines in a high-impedance state, and assert  $\overline{\text{HOLDA}}$ . On the TMS320C2x, program execution from on-chip ROM may proceed concurrently when the device is in the hold mode.

# TMS320 SECOND GENERATION DIGITAL SIGNAL PROCESSORS

SPRS010B — MAY 1987 — REVISED NOVEMBER 1990

---

## instruction set

The TMS320C2x microprocessor implements a comprehensive instruction set that supports both numeric-intensive signal processing operations as well as general-purpose applications, such as multiprocessing and high-speed control. The TMS32020 source code is upward-compatible with TMS320C25 source code. TMS32020 object code runs directly on the TMS320C25.

For maximum throughput, the next instruction is prefetched while the current one is being executed. Since the same data lines are used to communicate to external data/program or I/O space, the number of cycles may vary depending upon whether the next data operand fetch is from internal or external memory. Highest throughput is achieved by maintaining data memory on-chip and using either internal or fast external program memory.

## addressing modes

The TMS320C2x instruction set provides three memory addressing modes: direct, indirect, and immediate addressing.

Both direct and indirect addressing can be used to access data memory. In direct addressing, seven bits of the instruction word are concatenated with the nine bits of the data memory page pointer to form the 16-bit data memory address. Indirect addressing accesses data memory through the auxiliary registers. In immediate addressing, the data is based on a portion of the instruction word(s).

In direct memory addressing, the instruction word contains the lower seven bits of the data memory address. This field is concatenated with the nine bits of the data memory page pointer to form the full 16-bit address. Thus, memory is paged in the direct addressing mode with a total of 512 pages, each page containing 128 words.

Up to eight auxiliary registers (AR0-AR7) provide flexible and powerful indirect addressing (five on the TMS32020, eight on the TMS320C25). To select a specific auxiliary register, the Auxiliary Register Pointer (ARP) is loaded with a value from 0 to 7 for AR0 through AR7, respectively.

There are seven types of indirect addressing: auto-increment or auto-decrement, post-indexing by either adding or subtracting the contents of AR0, single indirect addressing with no increment or decrement, and bit-reversal addressing (used in FFTs on the TMS320C25 only) with increment or decrement. All operations are performed on the current auxiliary register in the same cycle as the original instruction, following which the current auxiliary register and ARP may be modified.

## repeat feature

A repeat feature, used with instructions such as multiply/accumulates, block moves, I/O transfers, and table read/writes, allows a single instruction to be performed up to 256 times. The repeat counter (RPTC) is loaded with either a data memory value (RPT instruction) or an immediate value (RPTK instruction). The value of this operand is one less than the number of times that the next instruction is executed. Those instructions that are normally multicycle are pipelined when using the repeat feature, and effectively become single-cycle instructions.



## instruction set summary

Table 2 lists the symbols and abbreviations used in Table 3, the TMS320C25 instruction set summary. Table 3 consists primarily of single-cycle, single-word instructions. Infrequently used branch, I/O, and CALL instructions are multicycle. The instruction set summary is arranged according to function and alphabetized within each functional grouping. The symbol (†) indicates those instructions that are not included in the TMS320C1x instruction set. The symbol (‡) indicates instructions that are not included in the TMS32020 instruction set.

**Table 2. Instruction Symbols**

SYMBOL	DEFINITION
B	4-bit field specifying a bit code
CM	2-bit field specifying compare mode
D	Data memory address field
FO	Format status bit
I	Addressing mode bit
K	Immediate operand field
PA	Port address (PA0 through PA15 are predefined assembler symbols equal to 0 through 15, respectively.)
PM	2-bit field specifying P register output shift code
AR	3-bit operand field specifying auxiliary register
S	4-bit left-shift code
X	3-bit accumulator left-shift field

# TMS320 SECOND GENERATION DIGITAL SIGNAL PROCESSORS

SPRS010B — MAY 1987 — REVISED NOVEMBER 1990

**Table 3. TMS320C25 Instruction Set Summary**

ACCUMULATOR MEMORY REFERENCE INSTRUCTIONS		NO. WORDS	INSTRUCTION BIT CODE																
MNEMONIC	DESCRIPTION		15	14	13	12	11	10	9	8	7	6	5	4	3	2	1	0	
ABS	Absolute value of accumulator	1	1	1	0	0	1	1	1	0	0	0	0	1	1	0	1	1	
ADD	Add to accumulator with shift	1	0	0	0	0	← S →		I	← D →									
ADDC‡	Add to accumulator with carry	1	0	1	0	0	0	0	1	1	I	← D →							
ADDH	Add to high accumulator	1	0	1	0	0	1	0	0	0	I	← D →							
ADDK‡	Add to accumulator short immediate	1	1	1	0	0	1	1	0	0	← K →								
ADDS	Add to low accumulator with sign extension suppressed	1	0	1	0	0	1	0	0	1	I	← D →							
ADDT	Add to accumulator with shift specified by T register	1	0	1	0	0	1	0	1	0	I	← D →							
ADLK†	Add to accumulator long immediate with shift	2	1	1	0	1	← S →		0	0	0	0	0	0	0	0	1	0	
AND	AND with accumulator	1	0	1	0	0	1	1	1	0	I	← D →							
ANDK†	AND immediate with accumulator with shift	2	1	1	0	1	← S →		0	0	0	0	0	0	1	0	0		
CMPL†	Complement accumulator	1	1	1	0	0	1	1	1	0	0	0	1	0	0	1	1		
LAC	Load accumulator with shift	1	0	0	1	0	← S →		I	← D →									
LACK	Load accumulator immediate short	1	1	1	0	0	1	0	1	0	← K →								
LACT†	Load accumulator with shift specified by T register	1	0	1	0	0	0	0	1	0	I	← D →							
LALK†	Load accumulator long immediate with shift	2	1	1	0	1	← S →		0	0	0	0	0	0	0	0	0	1	
NEG†	Negate accumulator	1	1	1	0	0	1	1	1	0	0	0	1	0	0	0	1		
NORM†	Normalize contents of accumulator	1	1	1	0	0	1	1	1	0	1	X	X	X	0	0	1		
OR	OR with accumulator	1	0	1	0	0	1	1	0	1	I	← D →							
ORK†	OR immediate with accumulator with shift	2	1	1	0	1	← S →		0	0	0	0	0	0	1	0	1		
ROL‡	Rotate accumulator left	1	1	1	0	0	1	1	1	0	0	0	1	1	0	1	0		
ROR‡	Rotate accumulator right	1	1	1	0	0	1	1	1	0	0	0	1	1	0	1	0		
SACH	Store high accumulator with shift	1	0	1	1	0	1	← X →		I	← D →								
SACL	Store low-order accumulator with shift	1	0	1	1	0	0	← X →		I	← D →								
sBLK†	Subtract from accumulator long immediate with shift	2	1	1	0	1	← S →		0	0	0	0	0	0	0	1	1		
SFL†	Shift accumulator left	1	1	1	0	0	1	1	1	0	0	0	0	1	1	0	0		
SFR†	Shift accumulator right	1	1	1	0	0	1	1	1	0	0	0	0	1	1	0	0		
SUB	Subtract from accumulator with shift	1	0	0	0	1	← S →		I	← D →									
SUBB‡	Subtract from accumulator with borrow	1	0	1	0	0	1	1	1	1	I	← D →							
SUBC	Conditional subtract	1	0	1	0	0	0	1	1	1	I	← D →							
SUBH	Subtract from high accumulator	1	0	1	0	0	0	1	0	0	I	← D →							
SUBK‡	Subtract from accumulator short immediate	1	1	1	0	0	1	1	0	1	← K →								
SUBS	Subtract from low accumulator with sign extension suppressed	1	0	1	0	0	0	1	0	1	I	← D →							

† These instructions are not included in the TMS320C1x instruction set.

‡ These instructions are not included in the TMS32020 instruction set.



**Table 3. TMS320C25 Instruction Set Summary (continued)**

ACCUMULATOR MEMORY REFERENCE INSTRUCTIONS																						
MNEMONIC	DESCRIPTION	NO. WORDS	INSTRUCTION BIT CODE																			
			15	14	13	12	11	10	9	8	7	6	5	4	3	2	1	0				
SUBT <sup>†</sup>	Subtract from accumulator with shift specified by T register	1	0	1	0	0	0	1	1	0	I	← D →										
XOR	Exclusive-OR with accumulator	1	0	1	0	0	1	1	0	0	I	← D →										
XORK <sup>†</sup>	Exclusive-OR immediate with accumulator with shift	2	1	1	0	1	← S →		0	0	0	0	0	1	1	0						
ZAC	Zero accumulator	1	1	1	0	0	1	0	1	0	0	0	0	0	0	0	0					
ZALH	Zero low accumulator and load high accumulator	1	0	1	0	0	0	0	0	0	I	← D →										
ZALR <sup>‡</sup>	Zero low accumulator and load high accumulator with rounding	1	0	1	1	1	1	0	1	1	I	← D →										
ZALS	Zero accumulator and load low accumulator with sign extension suppressed	1	0	1	0	0	0	0	0	1	I	← D →										
AUXILIARY REGISTERS AND DATA PAGE POINTER INSTRUCTIONS																						
MNEMONIC	DESCRIPTION	NO. WORDS	INSTRUCTION BIT CODE																			
			15	14	13	12	11	10	9	8	7	6	5	4	3	2	1	0				
ADRK <sup>‡</sup>	Add to auxiliary register short immediate	1	0	1	1	1	1	1	1	0	← K →											
CMPR <sup>†</sup>	Compare auxiliary register with auxiliary register ARO	1	1	1	0	0	1	1	1	0	0	1	0	1	0	0	← CM →					
LAR	Load auxiliary register	1	0	0	1	1	0	← R →		I	← D →											
LARK	Load auxiliary register short immediate	1	1	1	0	0	0	← R →		← K →												
LARP	Load auxiliary register pointer	1	0	1	0	1	0	1	0	1	1	0	0	0	1	← R →						
LDP	Load data memory page pointer	1	0	1	0	1	0	0	1	0	I	← D →										
LDPK	Load data memory page pointer immediate	1	1	1	0	0	1	0	0	← DP →												
LRLK <sup>†</sup>	Load auxiliary register long immediate	2	1	1	0	1	0	← R →		0	0	0	0	0	0	0	0					
MAR	Modify auxiliary register	1	0	1	0	1	0	1	0	1	I	← D →										
SAR	Store auxiliary register	1	0	1	1	1	0	← R →		I	← D →											
SBRK <sup>‡</sup>	Subtract from auxiliary register short immediate	1	0	1	1	1	1	1	1	1	← K →											

<sup>†</sup> These instructions are not included in the TMS320C1x instruction set.

<sup>‡</sup> These instructions are not included in the TMS32020 instruction set.

# TMS320 SECOND GENERATION DIGITAL SIGNAL PROCESSORS

SPRS010B — MAY 1987 — REVISED NOVEMBER 1990

**Table 3. TMS320C25 Instruction Set Summary (continued)**

		T REGISTER, P REGISTER, AND MULTIPLY INSTRUCTIONS																
MNEMONIC	DESCRIPTION	NO. WORDS	INSTRUCTION BIT CODE															
			15	14	13	12	11	10	9	8	7	6	5	4	3	2	1	0
APAC	Add P register to accumulator	1	1	1	0	0	1	1	1	0	0	0	0	1	0	1	0	1
LPH <sup>†</sup>	Load high P register	1	0	1	0	1	0	0	1	1		← D →			→			
LT	Load T register	1	0	0	1	1	1	1	0	0		← D →			→			
LTA	Load T register and accumulate previous product	1	0	0	1	1	1	1	0	1		← D →			→			
LTD	Load T register, accumulate previous product, and move data	1	0	0	1	1	1	1	1	1		← D →			→			
LTP <sup>†</sup>	Load T register and store P register in accumulator	1	0	0	1	1	1	1	1	0		← D →			→			
LTS <sup>†</sup>	Load T register and subtract previous product	1	0	1	0	1	1	0	1	1		← D →			→			
MAC <sup>†</sup>	Multiply and accumulate	2	0	1	0	1	1	1	0	1		← D →			→			
MACD <sup>†</sup>	Multiply and accumulate with data move	2	0	1	0	1	1	1	0	0		← D →			→			
MPY	Multiply (with T register, store product in P register)	1	0	0	1	1	1	0	0	0		← D →			→			
MPYA <sup>‡</sup>	Multiply and accumulate previous product	1	0	0	1	1	1	0	1	0		← D →			→			
MPYK	Multiply immediate	1	1	0	1	← K →						→						
MPYS <sup>‡</sup>	Multiply and subtract previous product	1	0	0	1	1	1	0	1	1		← D →			→			
MPYU <sup>‡</sup>	Multiply unsigned	1	1	1	0	0	1	1	1	1		← D →			→			
PAC	Load accumulator with P register	1	1	1	0	0	1	1	1	0	0	0	0	1	0	1	0	0
SPAC	Subtract P register from accumulator	1	1	1	0	0	1	1	1	0	0	0	0	1	0	1	1	0
SPH <sup>‡</sup>	Store high P register	1	0	1	1	1	1	1	0	1		← D →			→			
SPL <sup>‡</sup>	Store low P register	1	0	1	1	1	1	1	0	0		← D →			→			
SPM <sup>†</sup>	Set P register output shift mode	1	1	1	0	0	1	1	1	0	0	0	0	0	1	0	← PM →	
SQRA <sup>†</sup>	Square and accumulate	1	0	0	1	1	1	0	0	1		← D →			→			
SQRS <sup>†</sup>	Square and subtract previous product	1	0	1	0	1	1	0	1	0		← D →			→			

<sup>†</sup> These instructions are not included in the TMS320C1x instruction set.

<sup>‡</sup> These instructions are not included in the TMS32020 instruction set.



**Table 3. TMS320C25 Instruction Set Summary (continued)**

BRANCH/CALL INSTRUCTIONS																		
MNEMONIC	DESCRIPTION	NO. WORDS	INSTRUCTION BIT CODE															
			15	14	13	12	11	10	9	8	7	6	5	4	3	2	1	0
B	Branch unconditionally	2	1	1	1	1	1	1	1	1	1	1	← D →				1	
BACC†	Branch to address specified by accumulator	1	1	1	0	0	1	1	1	0	0	0	1	0	0	1	0	1
BANZ	Branch on auxiliary register not zero	2	1	1	1	1	1	0	1	1	1	← D →				1		
BBNZ†	Branch if TC bit ≠ 0	2	1	1	1	1	1	0	0	1	1	← D →				1		
BBZ†	Branch if TC bit = 0	2	1	1	1	1	1	0	0	0	1	← D →				1		
BC‡	Branch on carry	2	0	1	0	1	1	1	1	0	1	← D →				1		
BGEZ	Branch if accumulator ≥ 0	2	1	1	1	1	0	1	0	0	1	← D →				1		
BGZ	Branch if accumulator > 0	2	1	1	1	1	0	0	0	1	1	← D →				1		
BIOZ	Branch on I/O status = 0	2	1	1	1	1	1	0	1	0	1	← D →				1		
BLEZ	Branch if accumulator ≤ 0	2	1	1	1	1	0	0	1	0	1	← D →				1		
BLZ	Branch if accumulator < 0	2	1	1	1	1	0	0	1	1	1	← D →				1		
BNC‡	Branch on no carry	2	0	1	0	1	1	1	1	1	1	← D →				1		
BNV†	Branch if no overflow	2	1	1	1	1	0	1	1	1	1	← D →				1		
BNZ	Branch if accumulator ≠ 0	2	1	1	1	1	0	1	0	1	1	← D →				1		
BV	Branch on overflow	2	1	1	1	1	0	0	0	0	1	← D →				1		
BZ	Branch if accumulator = 0	2	1	1	1	1	0	1	1	0	1	← D →				1		
CALA	Call subroutine indirect	1	1	1	0	0	1	1	1	0	0	0	1	0	0	1	0	0
CALL	Call subroutine	2	1	1	1	1	1	1	1	0	1	← D →				1		
RET	Return from subroutine	1	1	1	0	0	1	1	1	0	0	0	1	0	0	1	1	0

I/O AND DATA MEMORY OPERATIONS																		
MNEMONIC	DESCRIPTION	NO. WORDS	INSTRUCTION BIT CODE															
			15	14	13	12	11	10	9	8	7	6	5	4	3	2	1	0
BLKD†	Block move from data memory to data memory	2	1	1	1	0	1	1	0	1	1	← D →				1		
BLKP†	Block move from program memory to data memory	2	1	1	1	1	1	1	0	0	1	← D →				1		
DMOV	Data move in data memory	1	0	1	0	1	0	1	1	0	1	← D →				1		
FORT†	Format serial port registers	1	1	1	0	0	1	1	1	0	0	0	0	0	1	1	1	FO
IN	Input data from port	1	1	0	0	0	← PA →		1	← D →				1				
OUT	Output data to port	1	1	1	1	0	← PA →		1	← D →				1				
RFSM‡	Reset serial port frame synchronization mode	1	1	1	0	0	1	1	1	0	0	0	1	1	0	1	1	0
RTXM†	Reset serial port transmit mode	1	1	1	0	0	1	1	1	0	0	0	1	0	0	0	0	0
RXF†	Reset external flag	1	1	1	0	0	1	1	1	0	0	0	0	0	1	1	0	0
SFSM‡	Set serial port frame synchronization mode	1	1	1	0	0	1	1	1	0	0	0	1	1	0	1	1	1
STXM†	Set serial port transmit mode	1	1	1	0	0	1	1	1	0	0	0	1	0	0	0	0	1
SXF†	Set external flag	1	1	1	0	0	1	1	1	0	0	0	0	0	1	1	0	1
TBLR	Table read	1	0	1	0	1	1	0	0	0	1	← D →				1		
TBLW	Table write	1	0	1	0	1	1	0	0	1	1	← D →				1		

† These instructions are not included in the TMS320C1x instruction set.

‡ These instructions are not included in the TMS32020 instruction set.

# TMS320 SECOND GENERATION DIGITAL SIGNAL PROCESSORS

SPRS010B — MAY 1987 — REVISED NOVEMBER 1990

**Table 3. TMS320C25 Instruction Set Summary (concluded)**

		CONTROL INSTRUCTIONS																	
MNEMONIC	DESCRIPTION	NO. WORDS	INSTRUCTION BIT CODE																
			15	14	13	12	11	10	9	8	7	6	5	4	3	2	1	0	
BIT†	Test bit	1	1	0	0	1	← B →		1	← D →									
BITT†	Test bit specified by T register	1	0	1	0	1	0	1	1	1	1	← D →							
CNFD†	Configure block as data memory	1	1	1	0	0	1	1	1	0	0	0	0	0	0	1	0	0	
CNFP†	Configure block as program memory	1	1	1	0	0	1	1	1	0	0	0	0	0	0	1	0	1	
DINT	Disable interrupt	1	1	1	0	0	1	1	1	0	0	0	0	0	0	0	0	1	
EINT	Enable interrupt	1	1	1	0	0	1	1	1	0	0	0	0	0	0	0	0	0	
IDLE†	Idle until interrupt	1	1	1	0	0	1	1	1	0	0	0	0	1	1	1	1	1	
LST	Load status register ST0	1	0	1	0	1	0	0	0	0	1	← D →							
LST1†	Load status register ST1	1	0	1	0	1	0	0	0	1	1	← D →							
NOP	No operation	1	0	1	0	1	0	1	0	1	0	0	0	0	0	0	0	0	
POP	Pop top of stack to low accumulator	1	1	1	0	0	1	1	1	0	0	0	0	1	1	1	0	1	
POPD†	Pop top of stack to data memory	1	0	1	1	1	1	0	1	0	1	← D →							
PSHD†	Push data memory value onto stack	1	0	1	0	1	0	1	0	0	1	← D →							
PUSH	Push low accumulator onto stack	1	1	1	0	0	1	1	1	0	0	0	0	1	1	1	0	0	
RC‡	Reset carry bit	1	1	1	0	0	1	1	1	0	0	0	1	1	0	0	0	0	
RHM‡	Reset hold mode	1	1	1	0	0	1	1	1	0	0	0	1	1	1	0	0	0	
ROVM	Reset overflow mode	1	1	1	0	0	1	1	1	0	0	0	0	0	0	0	1	0	
RPT†	Repeat instruction as specified by data memory value	1	0	1	0	0	1	0	1	1	1	← D →							
RPTK†	Repeat instruction as specified by immediate value	1	1	1	0	0	1	0	1	1	← K →								
RSXM†	Reset sign-extension mode	1	1	1	0	0	1	1	1	0	0	0	0	0	0	1	1	0	
RTC‡	Reset test/control flag	1	1	1	0	0	1	1	1	0	0	0	1	1	0	0	1	0	
SC‡	Set carry bit	1	1	1	0	0	1	1	1	0	0	0	1	1	0	0	0	1	
SHM‡	Set hold mode	1	1	1	0	0	1	1	1	0	0	0	1	1	1	0	0	1	
SOVM	Set overflow mode	1	1	1	0	0	1	1	1	0	0	0	0	0	0	0	1	1	
SST	Store status register ST0	1	0	1	1	1	1	0	0	0	1	← D →							
SST1†	Store status register ST1	1	0	1	1	1	1	0	0	1	1	← D →							
SSXM†	Set sign-extension mode	1	1	1	0	0	1	1	1	0	0	0	0	0	0	1	1	1	
STC‡	Set test/control flag	1	1	1	0	0	1	1	1	0	0	0	1	1	0	0	1	1	
TRAP†	Software interrupt	1	1	1	0	0	1	1	1	0	0	0	0	1	1	1	1	0	

† These instructions are not included in the TMS320C1x instruction set.

‡ These instructions are not included in the TMS32020 instruction set.





---

**TMS32020 PRODUCT NOTIFICATION**

Texas Instruments has identified an unusual set of circumstances that will cause the BIT (Test Bit) instruction on the TMS32020 to affect the contents of the accumulator; ideally, the BIT instruction should not affect the accumulator. This set of conditions is:

1. The overflow mode is set (the OVM status register bit is set to one.)
2. And, the two LSBs of the BIT instruction opcode word are zero.
  - a. When direct memory addressing is used, every fourth data word is affected; all other locations are not affected.
  - b. When indirect addressing is used, the two LSBs will be zero if a new ARP is not selected or if a new ARP is selected and that ARP is 0 or 4.
3. And, adding the contents of the accumulator with the contents of the addressed data memory location, shifted by 2<sup>(bit code)</sup>, causes an overflow of the accumulator.

If all of these conditions are met, the contents of the accumulator will be replaced by the positive or negative saturation value, depending on the polarity of the overflow.

Various methods for avoiding this phenomenon are available:

- If the TMS32020 is not in the saturation mode when the BIT instruction is executed, the device operates properly and the accumulator is not affected.
- Execute the Reset Overflow Mode (ROVM) instruction immediately prior to the BIT instruction and the Set Overflow Mode (SOVM) instruction immediately following the BIT instruction.
- If direct memory addressing is being used during the BIT instructions, reorganize memory so that the page relative locations 0, 4, 8, C, 10 . . . are not used.
- If indirect addressing is being used during the Bit instruction, select a new ARP which is not AR0 or AR4. If necessary, follow the instruction with a LARP AR0 or LARP AR4 to restore the code.
- Use the Test Bit Specified by T Register (BITT) instruction instead of the BIT instruction. The BITT instruction operates correctly and will not affect the accumulator under any circumstances.
- Replace TMS32020 with TMS320C25 for ideal pin-to-pin and object-code compatibility. The BIT instruction on the TMS320C25 executes properly and will not affect the accumulator under any circumstances.

# TMS320 SECOND GENERATION DIGITAL SIGNAL PROCESSORS

SPRS010B — MAY 1987 — REVISED NOVEMBER 1990

---

## development support

Together, Texas Instruments and its authorized third-party suppliers offer an extensive line of development support products to assist the user in all aspects of TMS320 second-generation-based design and development. These products range from development and application software to complete hardware development and evaluation systems. Table 4 lists the development support products for the second-generation TMS320 devices.

System development may begin with the use of the simulator, Software Development System (SWDS), or emulator (XDS) along with an assembler/linker. These tools give the TMS320 user various means of evaluation, from software simulation of the second-generation TMS320s (simulator) to full-speed in-circuit emulation with hardware and software breakpoint trace and timing capabilities (XDS).

Software and hardware can be developed simultaneously by using the macro assembler/linker, C compiler, and simulator for software development, the XDS for hardware development, and the Software Development System for both software development and limited hardware development.

Many third-party vendors offer additional development support for the second-generation TMS320s, including assembler/linkers, simulators, high-level languages, applications software, algorithm development tools, application boards, software development boards, and in-circuit emulators. Refer to the *TMS320 Family Development Support Reference Guide* (SPRU011A) for further information about TMS320 development support products offered by both Texas Instruments and its third-party suppliers.

Additional support for the TMS320 products consists of an extensive library or product and applications documentation. Three-day DSP design workshops are offered by the TI Regional Technology Centers (RTCs). These workshops provide insight into the architecture and the instruction set of the second-generation TMS320s as well as hands-on training with the TMS320 development tools. When technical questions arise regarding the TMS320 family, contact the Texas Instruments TMS320 Hotline at (713) 274-2320. Or, keep informed on the latest TI and third-party development support tools by accessing the DSP Bulletin Board Service (BBS) at (713) 274-2323. The BBS serves 2400-, 1200- and 300-bps modems. Also, TMS320 application source code may be downloaded from the BBS.



**Table 4. TMS320 Second-Generation Software and Hardware Support**

SOFTWARE TOOLS	PART NUMBER
Macro Assembler/Linker	
IBM MS/PC-DOS	TMDS3242850-02
VAX/VMS	TMDS3242250-08
VAX ULTRIX	TMDS3242260-08
SUN UNIX	TMDS3242550-08
Simulator	
IBM MS/PC-DOS	TMDS3242851-02
VAX/VMS	TMDS3242251-08
C Compiler	
IBM MS/PC-DOS	TMDX3242855-02
VAX/VMS	TMDX3242255-08
VAX ULTRIX	TMDX3242265-08
SUN UNIX	TMDX3242555-08
Digital Filter Design Package (DFDP)	
IBM PC-DOS	DFDP-IBM002
DSP Software Library	
IBM MS/PC-DOS	TMDC3240812-12
VAX/VMS	TMDC3204212-18
HARDWARE TOOLS	PART NUMBER
Analog Interface Board 2 (AIB2)	RTC/AIB320A-06
Analog Interface Board Adaptor	RTC/ADP320A-06
EPROM Programmer Adaptor Socket (68 to 28-pin)	TMDX3270120
Software Development System (SWDS)	TMDX3268821
XDS/22 Emulator (see Note)	TMDS3262221
XDS/22 Upgrade (TMS32020 to TMS320C2x)	TMDX3282226

NOTE: Emulation support for the TMS320C25-50 is available from Macrochip Research, Inc.; refer to the *TMS320 Family Development Support Reference Guide* (SPRU011A) for the mailing address.

**IBM** is a trademark of International Business Machines Corporation.  
**PC-DOS** is a trademark of International Business Machines Corporation.  
**VAX** and **VMS** are trademarks of Digital Equipment Corporation.  
**XDS** is a trademark of Texas Instruments Incorporated.



# TMS320 SECOND GENERATION DIGITAL SIGNAL PROCESSORS

SPRS010B — MAY 1987 — REVISED NOVEMBER 1990

---

## documentation support

Extensive documentation supports the second-generation TMS320 devices from product announcement through applications development. The types of documentation include data sheets with design specifications, complete user's guides, and 750 pages of application reports published in the book, *Digital Signal Processing Applications with the TMS320 Family* (SPRA012A). An application report, *Hardware Interfacing to the TMS320C25* (SPRA014A), is available for that device.

A series of DSP textbooks is being published by Prentice-Hall and John Wiley & Sons to support digital signal processing research and education. The TMS320 newsletter, *Details on Signal Processing*, is published quarterly and distributed to update TMS320 customers on product information. The TMS320 DSP bulletin board service provides access to large amounts of information pertaining to the TMS320 family.

Refer to the *TMS320 Family Development Support Reference Guide* (SPRU011A) for further information about TMS320 documentation. To receive copies of second-generation TMS320 literature, call the Customer Response Center at 1-800-232-3200.

## specification overview

The electrical specifications for the TMS32020, TMS320C25, TMS320E25, and TMS320C25-50 are given in the following pages. Note that the electrical specifications for the TMS320E25 are identical to those for the TMS320C25, with the addition of EPROM-related specifications. A summary of differences between TMS320C25 and TMS320C25-50 specifications immediately follows the TMS320C25-50 specification.

## absolute maximum ratings over specified temperature range (unless otherwise noted)†

Supply voltage range, $V_{CC}^{\ddagger}$	- 0.3 V to 7 V
Input voltage range	- 0.3 V to 7 V
Output voltage range	- 0.3 V to 7 V
Continuous power dissipation	2 W
Operating free-air temperature range	0°C to 70°C
Storage temperature range	- 55°C to 150°C

† Stresses beyond those listed under "Absolute Maximum Ratings" may cause permanent damage to the device. This is a stress rating only, and functional operation of the device at these or any other conditions beyond those indicated in the "Recommended Operating Conditions" section of this specification is not implied. Exposure to absolute-maximum-rated conditions for extended periods may affect device reliability.

‡ All voltage values are with respect to  $V_{SS}$ .

## recommended operating conditions

		MIN	NOM	MAX	UNIT	
$V_{CC}$	Supply voltage	4.75	5	5.25	V	
$V_{SS}$	Supply voltage		0		V	
$V_{IH}$	High-level input voltage	All inputs except CLKIN		2	$V_{CC} + 0.3$	V
		CLKIN		2.4	$V_{CC} + 0.3$	V
$V_{IL}$	Low-level input voltage	All inputs except CLKIN		- 0.3	0.8	V
		CLKIN		- 0.3	0.8	V
$I_{OH}$	High-level output current			300	$\mu$ A	
$I_{OL}$	Low-level output current			2	mA	
$T_A$	Operating free-air temperature (see Notes 1 and 2)	0		70	°C	

NOTES: 1. Case temperature ( $T_C$ ) must be maintained below 90°C.

2.  $R_{\theta JA} = 36^\circ\text{C/Watt}$ ,  $R_{\theta JC} = 6^\circ\text{C/Watt}$ .

## electrical characteristics over specified free-air temperature range (unless otherwise noted)

PARAMETER	TEST CONDITIONS	MIN	TYP <sup>§</sup>	MAX	UNIT
$V_{OH}$	High-level output voltage	2.4	3		V
$V_{OL}$	Low-level output voltage		0.3	0.6	V
$I_Z$	Three-state current	-20		20	$\mu$ A
$I_I$	Input current	-10		10	$\mu$ A
$I_{CC}$	Supply current	$T_A = 0^\circ\text{C}$ , $V_{CC} = \text{MAX}$ , $f_x = \text{MAX}$		360	mA
		$T_A = 25^\circ\text{C}$ , $V_{CC} = \text{MAX}$ , $f_x = \text{MAX}$		250	mA
		$T_C = 90^\circ\text{C}$ , $V_{CC} = \text{MAX}$ , $f_x = \text{MAX}$		285	mA
$C_I$	Input capacitance			15	pF
$C_O$	Output capacitance			15	pF

§ All typical values for  $I_{CC}$  are at  $V_{CC} = 5$  V,  $T_A = 25^\circ\text{C}$ .



This device contains circuits to protect its inputs and outputs against damage due to high static voltages or electrostatic fields. These circuits have been qualified to protect this device against electrostatic discharges (ESD) of up to 2 kV according to MIL-STD-883C, Method 3015; however, it is advised that precautions should be taken to avoid application of any voltage higher than maximum-rated voltages to these high-impedance circuits. During storage or handling, the device leads should be shorted together or the device should be placed in conductive foam. In a circuit, unused inputs should always be connected to an appropriated logic voltage level, preferably either  $V_{CC}$  or ground. Specific guidelines for handling devices of this type are contained in the publication *Guidelines for Handling Electrostatic-Discharge-Sensitive (ESDS) Devices and Assemblies* available from Texas Instruments.

## CLOCK CHARACTERISTICS AND TIMING

The TMS32020 can use either its internal oscillator or an external frequency source for a clock.

### internal clock option

The internal oscillator is enabled by connecting a crystal across X1 and X2/CLKIN (see Figure 2). The frequency of CLKOUT1 is one-fourth the crystal fundamental frequency. The crystal should be fundamental mode, and parallel resonant, with an effective series resistance of 30  $\Omega$ , a power dissipation of 1 mW, and be specified at a load capacitance of 20 pF.

PARAMETER	TEST CONDITIONS	MIN	TYP†	MAX	UNIT
$f_x$ Input clock frequency	$T_A = 0^\circ\text{C to } 70^\circ\text{C}$	6.7		20.5	MHz
$f_{xs}$ Serial port frequency	$T_A = 0^\circ\text{C to } 70^\circ\text{C}$	50†		2563	MHz
C1, C2	$T_A = 0^\circ\text{C to } 70^\circ\text{C}$		10		pF

† Value derived from characterization data; minimum  $f_{sx}$  at test = 825 kHz.

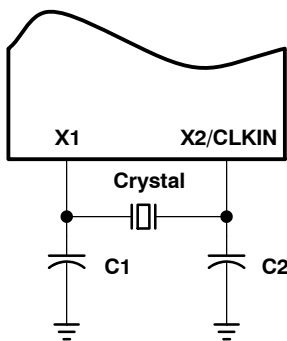

Figure 2. Internal Clock Option

### external clock option

An external frequency source can be used by injecting the frequency directly into X2/CLKIN with X1 left unconnected. The external frequency injected must conform to the specifications listed in the following table.

### switching characteristics over recommended operating conditions (see Note 3)

PARAMETER	MIN	NOM	MAX	UNIT
$t_{c(C)}$ CLKOUT1/CLKOUT2 cycle time	195		597	ns
$t_{d(CIH-C)}$ CLKIN high to CLKOUT1/CLKOUT2/STRB high/low	25		60	ns
$t_{f(C)}$ CLKOUT1/CLKOUT2/STRB fall time			10	ns
$t_{r(C)}$ CLKOUT1/CLKOUT2/STRB rise time			10	ns
$t_{w(CL)}$ CLKOUT1/CLKOUT2 low pulse duration	2Q - 15	2Q	2Q + 15	ns
$t_{w(CH)}$ CLKOUT1/CLKOUT2 high pulse duration	2Q - 15	2Q	2Q + 15	ns
$t_d(C1-C2)$ CLKOUT1 high to CLKOUT2 low, CLKOUT2 high to CLKOUT1 high, etc.	Q - 10	Q	Q + 10	ns

NOTE 3:  $Q = 1/4t_{c(C)}$ .

timing requirements over recommended operating conditions (see Note 3)

		MIN	NOM	MAX	UNIT
$t_{c(C)}$	CLKIN cycle time	195		597	ns
$t_{f(C)}$	CLKIN fall time			10 <sup>†</sup>	ns
$t_{r(C)}$	CLKIN rise time			10 <sup>†</sup>	ns
$t_{w(CIL)}$	CLKIN low pulse duration, $t_{c(C)} = 50$ ns (see Note 4)	40			ns
$t_{w(CIH)}$	CLKIN high pulse duration, $t_{c(C)} = 50$ ns (see Note 4)	40			ns
$t_{su(S)}$	$\overline{SYNC}$ setup time before CLKIN low	10		Q - 10	ns
$t_{h(S)}$	$\overline{SYNC}$ hold time from CLKIN low	15			ns

<sup>†</sup> Value derived from characterization data and not tested.

NOTES: 3.  $Q = 1/4t_{c(C)}$ .

4. CLKIN duty cycle  $[t_{r(C)} + t_{w(CIH)}] / t_{c(C)}$  must be within 40-60%.

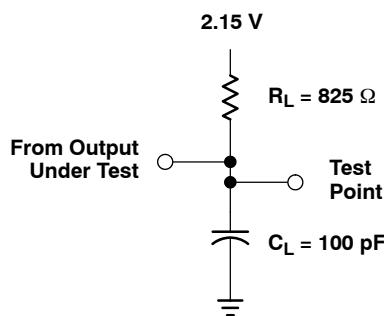
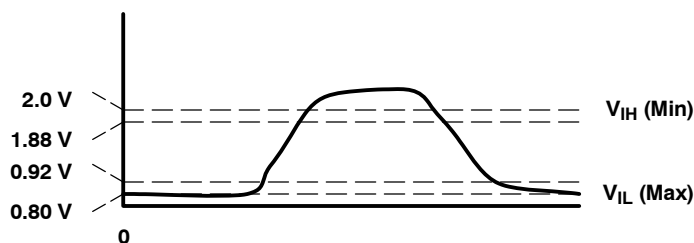
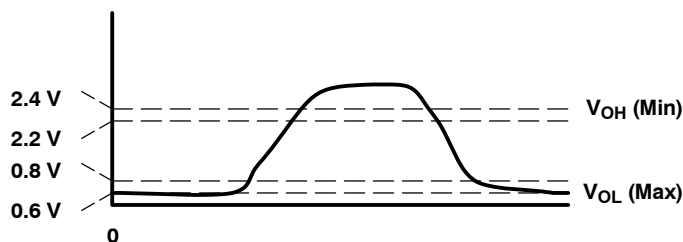

Figure 3. Test Load Circuit



(a) Input



(b) Output

Figure 4. Voltage Reference Levels

# TMS320 SECOND GENERATION DIGITAL SIGNAL PROCESSORS

SPRS010B — MAY 1987 — REVISED NOVEMBER 1990

## MEMORY AND PERIPHERAL INTERFACE TIMING

### switching characteristics over recommended operating conditions (see Note 3)

PARAMETER		MIN	TYP	MAX	UNIT
$t_{d(C1-S)}$	$\overline{STRB}$ from CLKOUT1 (if $\overline{STRB}$ is present)	Q - 15	Q	Q + 15	ns
$t_{d(C2-S)}$	CLKOUT2 to $\overline{STRB}$ (if $\overline{STRB}$ is present)	- 15	0	15	ns
$t_{su(A)}$	Address setup hold time before $\overline{STRB}$ low (see Note 5)	Q - 30			ns
$t_{h(A)}$	Address hold time after $\overline{STRB}$ high (see Note 5)	Q - 15			ns
$t_{w(SL)}$	$\overline{STRB}$ low pulse duration (no wait states, see Note 6)		2Q		ns
$t_{w(SH)}$	$\overline{STRB}$ high pulse duration (between consecutive cycles, see Note 6)		2Q		ns
$t_{su(D)W}$	Data write setup time before $\overline{STRB}$ high (no wait states)	2Q - 45			ns
$t_{h(D)W}$	Data write hold time from $\overline{STRB}$ high	Q - 15	Q		ns
$t_{en(D)}$	Data bus starts being driven after $\overline{STRB}$ low (write cycle)	0 <sup>†</sup>			ns
$t_{dis(D)}$	Data bus three-state after $\overline{STRB}$ high (write cycle)		Q	Q + 30 <sup>†</sup>	ns
$t_{d(MSC)}$	$\overline{MSC}$ valid from CLKOUT1	-25	0	25	ns

<sup>†</sup> Value derived from characterization data and not tested.

NOTES: 3.  $Q = 1/4t_{c(C)}$ .

5. A15-A0,  $\overline{PS}$ ,  $\overline{DS}$ ,  $\overline{IS}$ , R/ $\overline{W}$ , and  $\overline{BR}$  timings are all included in timings referenced as "address".

6. Delays between CLKOUT1/CLKOUT2 edges and  $\overline{STRB}$  edges track each other, resulting in  $t_{w(SL)}$  and  $t_{w(SH)}$  being 2Q with no wait states.

### timing requirements over recommended operating conditions (see Note 3)

		MIN	NOM	MAX	UNIT
$t_{a(A)}$	Read data access time from address time (read cycle, see Notes 5 and 7)			3Q - 70 <sup>†</sup>	ns
$t_{su(D)R}$	Data read setup time before $\overline{STRB}$ high	40			ns
$t_{h(D)R}$	Data read hold time from $\overline{STRB}$ high	0			ns
$t_{d(SL-R)}$	READY valid after $\overline{STRB}$ low (no wait states)			Q - 40	ns
$t_{d(C2H-R)}$	READY valid after CLKOUT2 high			Q - 40	ns
$t_{h(SL-R)}$	READY hold time after $\overline{STRB}$ low (no wait states)	Q - 5			ns
$t_{h(C2H-R)}$	READY hold after CLKOUT2 high	Q - 5			ns
$t_{d(M-R)}$	READY valid after $\overline{MSC}$ valid			2Q - 50	ns
$t_{h(M-R)}$	READY hold time after $\overline{MSC}$ valid	0			ns

<sup>†</sup> Value derived from characterization data and not tested.

NOTES: 3.  $Q = 1/4t_{c(C)}$ .

5. A15-A0,  $\overline{PS}$ ,  $\overline{DS}$ ,  $\overline{IS}$ , R/ $\overline{W}$ , and  $\overline{BR}$  timings are all included in timings referenced as "address".

7. Read data access time is defined as  $t_{a(A)} = t_{su(A)} + t_{w(SL)} - t_{su(D)R}$ .

ADVANCE INFORMATION





**$\overline{RS}$ ,  $\overline{INT}$ ,  $\overline{BIO}$ , AND XF TIMING**

**switching characteristics over recommended operating conditions (see Note 3 and 8)**

PARAMETER		MIN	TYP	MAX	UNIT
$t_{d(RS)}$	CLKOUT1 low to reset state entered			45	ns
$t_{d(IACK)}$	CLKOUT1 to $\overline{IACK}$ valid	- 25	0	25	ns
$t_{d(XF)}$	XF valid before falling edge of $\overline{STRB}$	Q - 30			ns

NOTES: 3.  $Q = 1/4t_{c(C)}$ .

8.  $\overline{RS}$ ,  $\overline{INT}$ , and  $\overline{BIO}$  are asynchronous inputs and can occur at any time during a clock cycle. However, if the specified setup time is met, the exact sequence shown in the timing diagrams will occur.

**timing requirements over recommended operating conditions (see Note 3 and 8)**

		MIN	NOM	MAX	UNIT
$t_{su(IN)}$	$\overline{INT}/\overline{BIO}/\overline{RS}$ setup before CLKOUT1 high	50			ns
$t_{h(IN)}$	$\overline{INT}/\overline{BIO}/\overline{RS}$ hold after CLKOUT1 high	0			ns
$t_{f(IN)}$	$\overline{INT}/\overline{BIO}$ fall time			15 <sup>†</sup>	ns
$t_{w(IN)}$	$\overline{INT}/\overline{BIO}$ low pulse duration	$t_{c(C)}$			ns
$t_{w(RS)}$	$\overline{RS}$ low pulse duration	$3t_{c(C)}$			ns

<sup>†</sup> Value derived from characterization data and not tested.

NOTES: 3.  $Q = 1/4t_{c(C)}$ .

8.  $\overline{RS}$ ,  $\overline{INT}$ , and  $\overline{BIO}$  are asynchronous inputs and can occur at any time during a clock cycle. However, if the specified setup time is met, the exact sequence shown in the timing diagrams will occur.

**HOLD TIMING**

**switching characteristics over recommended operating conditions (see Note 3)**

PARAMETER		MIN	TYP	MAX	UNIT
$t_{d(C1L-AL)}$	$\overline{HOLDA}$ low after CLKOUT1 low	-25 <sup>†</sup>		25	ns
$t_{dis(AL-A)}$	$\overline{HOLDA}$ low to address three-state		15 <sup>†</sup>		ns
$t_{dis(C1L-A)}$	Address three-state after CLKOUT1 low ( $\overline{HOLD}$ mode, see Note 9)			30 <sup>†</sup>	ns
$t_{d(HH-AH)}$	$\overline{HOLD}$ high to $\overline{HOLDA}$ high			50	ns
$t_{en(A-C1L)}$	Address driven before CLKOUT1 low ( $\overline{HOLD}$ mode, see Note 9)			10 <sup>†</sup>	ns

<sup>†</sup> Value derived from characterization data and not tested.

NOTES: 3.  $Q = 1/4t_{c(C)}$ .

9. A15-A0,  $\overline{PS}$ ,  $\overline{DS}$ ,  $\overline{IS}$ ,  $\overline{STRB}$ , and  $R/\overline{W}$  timings are all included in timings referenced as "address."

**timing requirements over recommended operating conditions (see Note 3)**

		MIN	NOM	MAX	UNIT
$t_{d(C2H-H)}$	$\overline{HOLD}$ valid after CLKOUT2 high			Q - 45	ns

NOTE 3:  $Q = 1/4t_{c(C)}$ .

**ADVANCE INFORMATION**



# TMS320 SECOND GENERATION DIGITAL SIGNAL PROCESSORS

SPRS010B — MAY 1987 — REVISED NOVEMBER 1990

## SERIAL PORT TIMING

### switching characteristics over recommended operating conditions (see Note 3)

PARAMETER		MIN	TYP	MAX	UNIT
$t_{d(CH-DX)}$	DX valid after CLKX rising edge (see Note 10)			100	ns
$t_{d(FL-DX)}$	DX valid after FSX falling edge (TXM = 0, see Note 10)			50	ns
$t_{d(CH-FS)}$	FSX valid after CLKX rising edge (TXM = 1)			60	ns

NOTES: 3.  $Q = 1/4t_{c(C)}$ .

10. The last occurrence of FSX falling and CLKX rising.

### timing requirements over recommended operating conditions (see Note 3)

		MIN	NOM	MAX	UNIT
$t_{c(SCK)}$	Serial port clock (CLKX/CLKR) cycle time	390		20 000 <sup>†</sup>	ns
$t_{f(SCK)}$	Serial port clock (CLKX/CLKR) fall time			50 <sup>‡</sup>	ns
$t_{r(SCK)}$	Serial port clock (CLKX/CLKR) rise time			50 <sup>‡</sup>	ns
$t_{w(SCK)}$	Serial port clock (CLKX/CLKR) low pulse duration (see Note 11)	150		12 000	ns
$t_{w(SCK)}$	Serial port clock (CLKX/CLKR) high pulse duration (see Note 11)	150		12 000	ns
$t_{su(FS)}$	FSX/FSR setup time before CLKX/CLKR falling edge (TXM = 0)	20			ns
$t_{h(FS)}$	FSX/FSR hold time after CLKX/CLKR falling edge (TXM = 0)	20			ns
$t_{su(DR)}$	DR setup time before CLKR falling edge	20			ns
$t_{h(DR)}$	DR hold time after CLKR falling edge	20			ns

<sup>†</sup> Value derived from characterization data; minimum  $f_{sx}$  at test = 825 kHz.

<sup>‡</sup> Value derived from characterization data and not tested.

NOTES: 3.  $Q = 1/4t_{c(C)}$ .

11. The duty cycle of the serial port clock must be within 40-60%.

ADVANCE INFORMATION



## absolute maximum ratings over specified temperature range (unless otherwise noted)<sup>†</sup>

Supply voltage range, $V_{CC}$ <sup>‡</sup>	- 0.3 V to 7 V
Input voltage range: TMS320E25 pins 24 and 25	- 0.3 V to 15 V
All other inputs	- 0.3 V to 7 V
Output voltage range	- 0.3 V to 7 V
Continuous power dissipation	1.5 W
Operating free-air temperature range	0°C to 70°C
Storage temperature range	- 55°C to 150°C

<sup>†</sup> Stresses beyond those listed under "Absolute Maximum Ratings" may cause permanent damage to the device. This is a stress rating only, and functional operation of the device at these or any other conditions beyond those indicated in the "Recommended Operating Conditions" section of this specification is not implied. Exposure to absolute-maximum-rated conditions for extended periods may affect device reliability.

<sup>‡</sup> All voltage values are with respect to  $V_{SS}$ .

## recommended operating conditions

		MIN	NOM	MAX	UNIT
$V_{CC}$	Supply voltage	4.75	5	5.25	V
$V_{SS}$	Supply voltage		0		V
$V_{IH}$	High-level input voltage	All inputs except CLKIN/CLKX/CLKR/ $\overline{INT}$ (0-2)	2.35	$V_{CC} + 0.3$	V
		$\overline{INT}$ (0-2)	2.5	$V_{CC} + 0.3$	V
		CLKIN/CLKX/CLKR	3.5	$V_{CC} + 0.3$	V
$V_{IL}$	Low-level input voltage	All inputs except MP/ $\overline{MC}$	- 0.3	0.8	V
		MP/ $\overline{MC}$	- 0.3	0.8	V
$I_{OH}$	High-level output current			300	$\mu$ A
$I_{OL}$	Low-level output current			2	mA
$T_A$	Operating free-air temperature	TMS320C25, TMS320E25	0	70	°C
		TMS320C25GBA	- 40	85	°C

## electrical characteristics over specified free-air temperature range (unless otherwise noted)

PARAMETER		TEST CONDITIONS	MIN	TYP <sup>§</sup>	MAX	UNIT
$V_{OH}$	High-level output voltage	$V_{CC} = \text{MIN}, I_{OH} = \text{MAX}$	2.4	3		V
$V_{OL}$	Low-level output voltage	$V_{CC} = \text{MIN}, I_{OL} = \text{MAX}$		0.3	0.6	V
$I_Z$	Three-state current	$V_{CC} = \text{MAX}$	-20		20	$\mu$ A
$I_I$	Input current	$V_I = V_{SS} \text{ to } V_{CC}$	-10		10	$\mu$ A
$I_{CC}$	Low-level input voltage	Normal Idle/HOLD	$T_A = 0^\circ\text{C}, V_{CC} = \text{MAX}, f_x = \text{MAX}$	110	185	mA
				50	100	
$C_I$	Input capacitance			15		pF
$C_O$	Output capacitance			15		pF

<sup>§</sup> All typical values are at  $V_{CC} = 5 \text{ V}, T_A = 25^\circ$ .



Caution. This device contains circuits to protect its inputs and outputs against damage due to high static voltages or electrostatic fields. These circuits have been qualified to protect this device against electrostatic discharges (ESD) of up to 2 kV according to MIL-STD-883C, Method 3015; however, it is advised that precautions be taken to avoid application of any voltage higher than maximum rated voltages to these high-impedance circuits. During storage or handling, the device leads should be shorted together or the device should be placed in conductive foam. In a circuit, unused inputs should always be connected to an appropriate logic voltage level, preferably either  $V_{CC}$  or ground. Specific guidelines for handling devices of this type are contained in the publication "Guidelines for Handling Electrostatic-Discharge Sensitive (ESDS) Devices and Assemblies" available from Texas Instruments

## CLOCK CHARACTERISTICS AND TIMING

The TMS32025 can use either its internal oscillator or an external frequency source for a clock.

### internal clock option

The internal oscillator is enabled by connecting a crystal across X1 and X2/CLKIN (see Figure 2). The frequency of CLKOUT1 is one-fourth the crystal fundamental frequency. The crystal should be either fundamental or overtone mode, and parallel resonant, with an effective series resistance of 30  $\Omega$ , a power dissipation of 1 mW, and be specified at a load capacitance of 20 pF. Note that overtone crystals require an additional tuned LC circuit; see the application report, *Hardware Interfacing to the TMS320C25* (SPRA014A).

PARAMETER	TEST CONDITIONS	MIN	TYP	MAX	UNIT
$f_x$ Input clock frequency	$T_A = 0^\circ\text{C to } 70^\circ\text{C}$	6.7		40.96	MHz
$f_{xs}$ Serial port frequency	$T_A = 0^\circ\text{C to } 70^\circ\text{C}$	0 <sup>†</sup>		5120	MHz
C1, C2	$T_A = 0^\circ\text{C to } 70^\circ\text{C}$		10		pF

<sup>†</sup> The serial port was tested at a minimum frequency of 1.25 MHz. However, the serial port was fully static but will properly function down to  $f_{sx} = 0$  Hz.

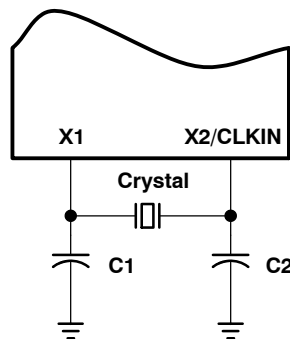

Figure 2. Internal Clock Option

### external clock option

An external frequency source can be used by injecting the frequency directly into X2/CLKIN with X1 left unconnected. The external frequency injected must conform to the specifications listed in the following table.

### switching characteristics over recommended operating conditions (see Note 3)

PARAMETER	MIN	TYP	MAX	UNIT
$t_{c(C)}$ CLKOUT1/CLKOUT2 cycle time	97.7		597	ns
$t_{d(CIH-C)}$ CLKIN high to CLKOUT1/CLKOUT2/STRB high/low	5		30	ns
$t_{f(C)}$ CLKOUT1/CLKOUT2/STRB fall time			5	ns
$t_{r(C)}$ CLKOUT1/CLKOUT2/STRB rise time			5	ns
$t_{w(CL)}$ CLKOUT1/CLKOUT2 low pulse duration	$2Q - 8$	$2Q$	$2Q + 8$	ns
$t_{w(CH)}$ CLKOUT1/CLKOUT2 high pulse duration	$2Q - 8$	$2Q$	$2Q + 8$	ns
$t_{d(C1-C2)}$ CLKOUT1 high to CLKOUT2 low, CLKOUT2 high to CLKOUT1 high, etc.	$Q - 5$	$Q$	$Q + 5$	ns

NOTE 3:  $Q = 1/4t_{c(C)}$ .

## timing requirements over recommended operating conditions (see Note 3)

		MIN	NOM	MAX	UNIT
$t_{c(CK)}$	CLKIN cycle time	24.4		150	ns
$t_{f(CK)}$	CLKIN fall time			5 <sup>†</sup>	ns
$t_{r(CK)}$	CLKIN rise time			5 <sup>†</sup>	ns
$t_{w(CL)}$	CLKIN low pulse duration, $t_{c(CK)} = 50$ ns (see Note 4)	20			ns
$t_{w(CH)}$	CLKIN high pulse duration, $t_{c(CK)} = 50$ ns (see Note 4)	20			ns
$t_{su(S)}$	$\overline{SYNC}$ setup time before CLKIN low	5		Q - 5	ns
$t_{h(S)}$	$\overline{SYNC}$ hold time from CLKIN low	8			ns

<sup>†</sup> Value derived from characterization data and not tested.

NOTES: 3.  $Q = 1/4t_{c(CK)}$ .

4. CLKIN duty cycle  $[t_{r(CK)} + t_{w(CH)}]/t_{c(CK)}$  must be within 40-60%.

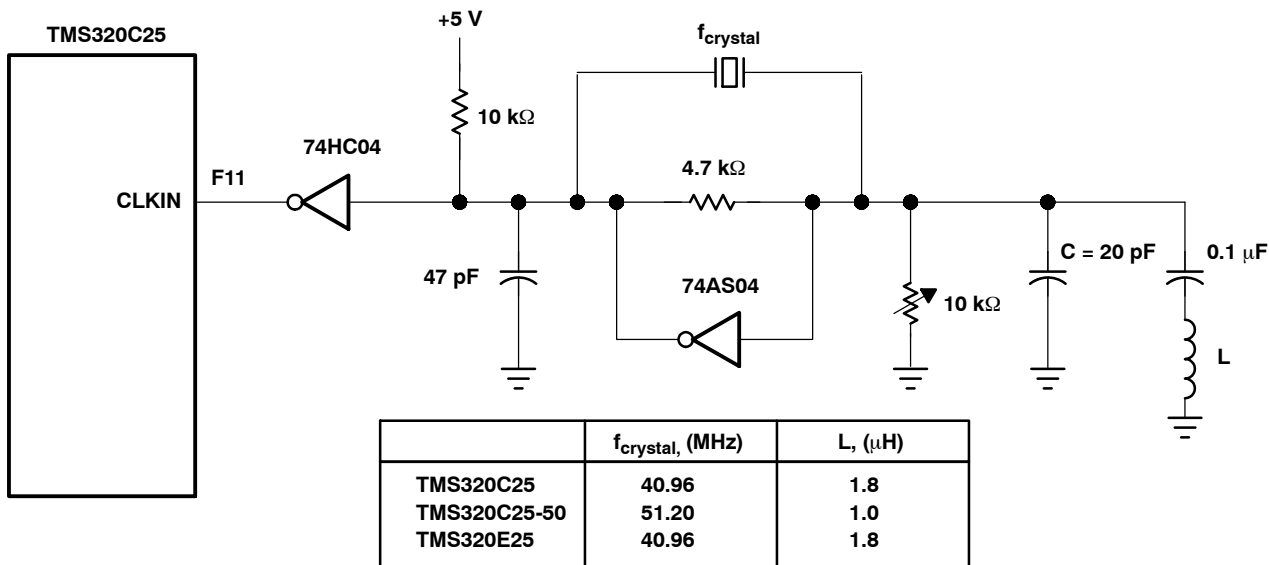

Figure 3. External Clock Option

Shown above is a crystal oscillator circuit suitable for providing the input clock signal to the TMS320C25, TMS320E25, and TMS320C25-50. Please refer to *Hardware Interfacing to the TMS320C25* (document number SPRA014A) for details on circuit operation.

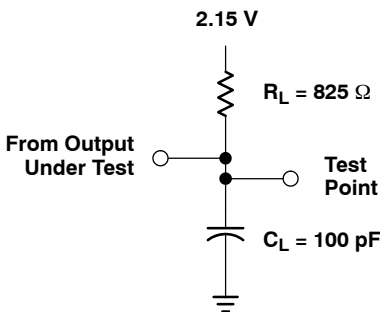

Figure 4. Test Load Circuit

# TMS320 SECOND GENERATION DIGITAL SIGNAL PROCESSORS

SPRS010B — MAY 1987 — REVISED NOVEMBER 1990

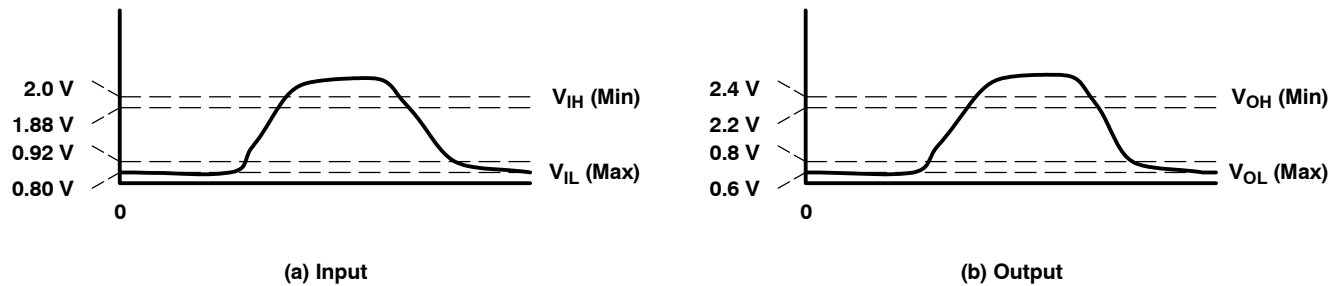

Figure 5. Voltage Reference Levels

## MEMORY AND PERIPHERAL INTERFACE TIMING

switching characteristics over recommended operating conditions (see Note 3)

PARAMETER		MIN	TYP	MAX	UNIT
$t_{d(C1-S)}$	STRB from CLKOUT1 (if STRB is present)	Q - 6	Q	Q + 6	ns
$t_{d(C2-S)}$	CLKOUT2 to STRB (if STRB is present)	- 6	0	6	ns
$t_{su(A)}$	Address setup time before STRB low (see Note 5)	Q - 12			ns
$t_{h(A)}$	Address hold time after STRB high (see Note 5)	Q - 8			ns
$t_{w(SL)}$	STRB low pulse duration (no wait states, see Note 6)	2Q - 5		2Q + 5	ns
$t_{w(SH)}$	STRB high pulse duration (between consecutive cycles, see Note 6)	2Q - 5		2Q + 5	ns
$t_{su(D)W}$	Data write setup time before STRB high (no wait states)	2Q - 20			ns
$t_{h(D)W}$	Data write hold time from STRB high	Q - 10	Q		ns
$t_{en(D)}$	Data bus starts being driven after STRB low (write cycle)	0 <sup>†</sup>			ns
$t_{dis(D)}$	Data bus three-state after STRB high (write cycle)		Q	Q + 15 <sup>†</sup>	ns
$t_{d(MSC)}$	MSC valid from CLKOUT1	- 12	0	12	ns

<sup>†</sup> Value derived from characterization data and not tested.

NOTES: 3.  $Q = 1/4t_{c(C)}$ .

5. A15-A0, PS, DS, IS, R/W, and BR timings are all included in timings referenced as "address".

6. Delays between CLKOUT1/CLKOUT2 edges and STRB edges track each other, resulting in  $t_{w(SL)}$  and  $t_{w(SH)}$  being 2Q with no wait states.

timing requirements over recommended operating conditions (see Note 3)

		MIN	NOM	MAX	UNIT
$t_{a(A)}$	Read data access time from address time (read cycle, see Notes 5 and 7)			3Q - 35	ns
$t_{su(D)R}$	Data read setup time before STRB high	23			ns
$t_{h(D)R}$	Data read hold time from STRB high	0			ns
$t_{d(SL-R)}$	READY valid after STRB low (no wait states)			Q - 20	ns
$t_{d(C2H-R)}$	READY valid after CLKOUT2 high			Q - 20	ns
$t_{h(SL-R)}$	READY hold time after STRB low (no wait states)	Q + 3			ns
$t_{h(C2H-R)}$	READY hold after CLKOUT2 high	Q + 3			ns
$t_{d(M-R)}$	READY valid after MSC valid			2Q - 25	ns
$t_{h(M-R)}$	READY hold time after MSC valid	0			ns

NOTES: 3.  $Q = 1/4t_{c(C)}$ .

5. A15-A0, PS, DS, IS, R/W, and BR timings are all included in timings referenced as "address".

7. Read data access time is defines as  $t_{a(A)} = t_{su(A)} + t_{w(SL)} - t_{su(D)R}$ .

ADVANCE INFORMATION



POST OFFICE BOX 1443 • HOUSTON, TEXAS 77001

**$\overline{RS}$ ,  $\overline{INT}$ ,  $\overline{BIO}$ , AND XF TIMING**

**switching characteristics over recommended operating conditions (see Note 3 and 8)**

PARAMETER		MIN	TYP	MAX	UNIT
$t_{d(RS)}$	CLKOUT1 low to reset state entered			22 <sup>†</sup>	ns
$t_{d(IACK)}$	CLKOUT1 to $\overline{IACK}$ valid	- 6	0	12	ns
$t_{d(XF)}$	XF valid before falling edge of $\overline{STRB}$	Q - 15			ns

- NOTES: 3.  $Q = 1/4t_{c(C)}$ .  
 8.  $\overline{RS}$ ,  $\overline{INT}$ , and  $\overline{BIO}$  are asynchronous inputs and can occur at any time during a clock cycle. However, if the specified setup time is met, the exact sequence shown in the timing diagrams will occur.

**timing requirements over recommended operating conditions (see Note 3 and 8)**

		MIN	NOM	MAX	UNIT
$t_{su(IN)}$	$\overline{INT}/\overline{BIO}/\overline{RS}$ setup before CLKOUT1 high	32			ns
$t_{h(IN)}$	$\overline{INT}/\overline{BIO}/\overline{RS}$ hold after CLKOUT1 high	0			ns
$t_{f(IN)}$	$\overline{INT}/\overline{BIO}$ fall time			8 <sup>†</sup>	ns
$t_{w(IN)}$	$\overline{INT}/\overline{BIO}$ low pulse duration	$t_{c(C)}$			ns
$t_{w(RS)}$	$\overline{RS}$ low pulse duration	$3t_{c(C)}$			ns

- <sup>†</sup> Value derived from characterization data and not tested.  
 NOTES: 3.  $Q = 1/4t_{c(C)}$ .  
 8.  $\overline{RS}$ ,  $\overline{INT}$ , and  $\overline{BIO}$  are asynchronous inputs and can occur at any time during a clock cycle. However, if the specified setup time is met, the exact sequence shown in the timing diagrams will occur.

**HOLD TIMING**

**switching characteristics over recommended operating conditions (see Note 3)**

PARAMETER		MIN	TYP	MAX	UNIT
$t_{d(C1L-AL)}$	$\overline{HOLDA}$ low after CLKOUT1 low	0		10	ns
$t_{dis(AL-A)}$	$\overline{HOLDA}$ low to address three-state		0 <sup>†</sup>		ns
$t_{dis(C1L-A)}$	Address three-state after CLKOUT1 low ( $\overline{HOLD}$ mode, see Note 9)			20 <sup>†</sup>	ns
$t_{d(HH-AH)}$	$\overline{HOLD}$ high to $\overline{HOLDA}$ high			25	ns
$t_{en(A-C1L)}$	Address driven before CLKOUT1 low ( $\overline{HOLD}$ mode, see Note 9)			8 <sup>†</sup>	ns

- <sup>†</sup> Value derived from characterization data and not tested.  
 NOTES: 3.  $Q = 1/4t_{c(C)}$ .  
 9. A15-A0,  $\overline{PS}$ ,  $\overline{DS}$ ,  $\overline{IS}$ ,  $\overline{STRB}$ , and  $R/\overline{W}$  timings are all included in timings referenced as "address."

**timing requirements over recommended operating conditions (see Note 3)**

		MIN	NOM	MAX	UNIT
$t_{d(C2H-H)}$	$\overline{HOLD}$ valid after CLKOUT2 high			Q - 24	ns

NOTE 3:  $Q = 1/4t_{c(C)}$ .

**ADVANCE INFORMATION**



# TMS320 SECOND GENERATION DIGITAL SIGNAL PROCESSORS

SPRS010B — MAY 1987 — REVISED NOVEMBER 1990

## SERIAL PORT TIMING

### switching characteristics over recommended operating conditions (see Note 3)

PARAMETER		MIN	TYP	MAX	UNIT
$t_{d(CH-DX)}$	DX valid after CLKX rising edge (see Note 10)			75	ns
$t_{d(FL-DX)}$	DX valid after FSX falling edge (TXM = 0, see Note 10)			40	ns
$t_{d(CH-FS)}$	FSX valid after CLKX rising edge (TXM = 1)			40	ns

NOTES: 3.  $Q = 1/4t_{c(C)}$ .

10. The last occurrence of FSX falling and CLKX rising.

### timing requirements over recommended operating conditions (see Note 3)

		MIN	NOM	MAX	UNIT
$t_{c(SCK)}$	Serial port clock (CLKX/CLKR) cycle time <sup>†</sup>	200			ns
$t_{f(SCK)}$	Serial port clock (CLKX/CLKR) fall time			25 <sup>‡</sup>	ns
$t_{r(SCK)}$	Serial port clock (CLKX/CLKR) rise time			25 <sup>‡</sup>	ns
$t_{w(SCK)}$	Serial port clock (CLKX/CLKR) low pulse duration (see Note 11)	80			ns
$t_{w(SCK)}$	Serial port clock (CLKX/CLKR) high pulse duration (see Note 11)	80			ns
$t_{su(FS)}$	FSX/FSR setup time before CLKX/CLKR falling edge (TXM = 0)	18			ns
$t_{h(FS)}$	FSX/FSR hold time after CLKX/CLKR falling edge (TXM = 0)	20			ns
$t_{su(DR)}$	DR setup time before CLKR falling edge	10			ns
$t_{h(DR)}$	DR hold time after CLKR falling edge	20			ns

<sup>†</sup> The serial port was tested at a minimum frequency of 1.25 MHz. However, the serial port was fully static but will properly function down to  $f_{sx} = 0$  Hz.

<sup>‡</sup> Value derived from characterization data and not tested.

NOTES: 3.  $Q = 1/4t_{c(C)}$ .

11. The duty cycle of the serial port clock must be within 40-60%.

ADVANCE INFORMATION





## EPROM PROGRAMMING

### absolute maximum ratings over specified temperature range (unless otherwise noted)<sup>†</sup>

Supply voltage range, $V_{PP}$ <sup>‡</sup> .....	– 0.6 V to 15 V
Input voltage range on pins 24 and 25 .....	– 0.3 V to 15 V

<sup>†</sup> Stresses beyond those listed under “Absolute Maximum Ratings” may cause permanent damage to the device. This is a stress rating only, and functional operation of the device at these or any other conditions beyond those indicated in the “Recommended Operating Conditions” section of this specification is not implied. Exposure to absolute-maximum-rated conditions for extended periods may affect device reliability.

<sup>‡</sup> All voltage values are with respect to GND.

### recommended operating conditions

	MIN	NOM	MAX	UNIT
$V_{CC}$ Programming mode supply voltage (see Note 13)		6		V
$V_{CC}$ Read mode supply voltage	4.75	5	5.25	V
$V_{PP}$ Programming mode supply voltage	12	12.5	13	V
$V_{PP}$ Read mode supply voltage (see Note 12)		$V_{CC}$		V

NOTES: 12.  $V_{PP}$  can be connected to  $V_{CC}$  directly (except in the program mode).  $V_{CC}$  supply current in this case would be  $I_{CC} + I_{PP}$ . During programming,  $V_{PP}$  must be maintained at 12.5 V ( $\pm 0.25$  V).

13.  $V_{CC}$  must be applied before or at the same time as  $V_{PP}$  and removed after or at the same time as  $V_{PP}$ . This device must not be inserted into or removed from the board when  $V_{PP}$  or  $V_{CC}$  is applied.

### electrical characteristics over specified temperature range (unless otherwise noted)

PARAMETER	TEST CONDITIONS	MIN	TYP <sup>§</sup>	MAX	UNIT
$I_{PP1}$ $V_{PP}$ supply current	$V_{PP} = V_{CC} = 5.25$ V			100	$\mu$ A
$I_{PP2}$ $V_{PP}$ supply current (during program pulse)	$V_{PP} = 13$ V		30	50	mA

<sup>§</sup> All typical values for  $I_{CC}$  are at  $V_{CC} = 5$  V,  $T_A = 25^\circ\text{C}$ .

### recommended timing requirements for programming, $T_A = 25^\circ\text{C}$ , $V_{CC} = 6$ V, $V_{PP} = 12.5$ V (see Notes 14 and 15)

	MIN	NOM	MAX	UNIT
$t_{w(IPGM)}$ Initial program pulse duration	0.95	1	1.05	ms
$t_{w(FPGM)}$ Final pulse duration	2.85		78.75	ms
$t_{su(A)}$ Address setup time	2			$\mu$ s
$t_{su(E)}$ $\bar{E}$ setup time	2			$\mu$ s
$t_{su(G)}$ $\bar{G}$ setup time	2			$\mu$ s
$t_{dis(G)}$ Output disable time from $\bar{G}$	0		130 <sup>¶</sup>	ns
$t_{en(G)}$ Output enable time from $\bar{G}$			150 <sup>¶</sup>	ns
$t_{su(D)}$ Data setup time	2			$\mu$ s
$t_{su(VPP)}$ $V_{PP}$ setup time	2			$\mu$ s
$t_{su(VCC)}$ $V_{CC}$ setup time	2			$\mu$ s
$t_{h(A)}$ Address hold time	0			$\mu$ s
$t_{h(D)}$ Data hold time	2			$\mu$ s

<sup>¶</sup> Value derived from characterization data and not tested.

NOTES: 14. For all switching characteristics and timing measurements, input pulse levels are 0.4 V to 2.4 V and  $V_{PP} = 12.5$  V  $\pm 0.5$  V during programming.

15. Common test conditions apply for  $t_{dis(G)}$  except during programming.

**absolute maximum ratings over specified temperature range (unless otherwise noted)†**

Supply voltage range, $V_{CC}^{\ddagger}$	.....	- 0.3 V to 7 V
Input voltage range	.....	- 0.3 V to 7 V
Output voltage range	.....	- 0.3 V to 7 V
Continuous power dissipation	.....	1.5 W
Operating free-air temperature range	.....	0°C to 70°C
Storage temperature range	.....	- 55°C to 150°C

† Stresses beyond those listed under "Absolute Maximum Ratings" may cause permanent damage to the device. This is a stress rating only, and functional operation of the device at these or any other conditions beyond those indicated in the "Recommended Operating Conditions" section of this specification is not implied. Exposure to absolute-maximum-rated conditions for extended periods may affect device reliability.

‡ All voltage values are with respect to  $V_{SS}$ .

**recommended operating conditions**

		MIN	NOM	MAX	UNIT
$V_{CC}$	Supply voltage	4.75	5	5.25	V
$V_{SS}$	Supply voltage		0		V
$V_{IH}$	High-level input voltage	INT0-INT2	2.5		V
		CLKIN, CLKX, CLKR	3.5		V
		Other inputs	2.35		V
$V_{IL}$	Low-level input voltage	MP/MC		0.8	V
		CLKIN		0.8	V
		Other inputs		0.8	V
$I_{OH}$	High-level output current			300	$\mu$ A
$I_{OL}$	Low-level output current			2	mA
$T_A$	Operating free-air temperature	0		70	°C

**electrical characteristics over specified free-air temperature range (unless otherwise noted)**

PARAMETER		TEST CONDITIONS	MIN	TYP <sup>§</sup>	MAX	UNIT
$V_{OH}$	High-level output voltage	$V_{CC} = \text{MIN}, I_{OH} = \text{MAX}$	2.4			V
$V_{OL}$	Low-level output voltage	$V_{CC} = \text{MIN}, I_{OL} = \text{MAX}$			0.6	V
$I_Z$	High-impedance current	$V_{CC} = \text{MAX}$	- 20		20	$\mu$ A
$I_I$	Input current	$V_I = V_{SS} \text{ to } V_{CC}$	- 10		10	$\mu$ A
$I_{CC}$	Supply current	Normal		110	185	mA
		Idle, HOLD		50	100	
$C_I$	Input capacitance			15		pF
$C_O$	Output capacitance			15		pF

§ All typical values are at  $V_{CC} = 5 \text{ V}, T_A = 25^\circ\text{C}$ .

ADVANCE INFORMATION



## CLOCK CHARACTERISTICS AND TIMING

The TMS320C25-50 can use either its internal oscillator or an external frequency source for a clock.

### internal clock option

The internal oscillator is enabled by connecting a crystal across X1 and X2, CLKIN. The frequency of CLKOUT1 is one-fourth the crystal fundamental frequency. The crystal should be in either fundamental or overtone mode, and parallel resonant, with an effective series resistance of 30  $\Omega$ , a power dissipation of 1 mW, and be specified at a load capacitance of 20 pF. Note that overtone crystals require an additional tuned LC circuit.

PARAMETER	TEST CONDITIONS	MIN	TYP <sup>†</sup>	MAX	UNIT
$f_x$ Input clock frequency	$T_A = 0^\circ\text{C to } 70^\circ\text{C}$	6.7		51.2	MHz
$f_{sx}$ Serial port frequency	$T_A = 0^\circ\text{C to } 70^\circ\text{C}$	0		6.4	MHz
C1, C2	$T_A = 0^\circ\text{C to } 70^\circ\text{C}$		10		pF

<sup>†</sup> The serial port was tested at a minimum frequency of 1.25 MHz. However, the serial port was fully static but will properly function down to  $f_{sx} = 0$  Hz.

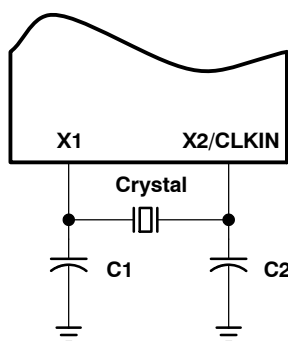

Figure 6. Internal Clock Option

### external clock option

An external frequency source can be used by injecting the frequency directly into X2/CLK, with X1 left unconnected. The external frequency injected must conform to specifications listed in the following table.

### switching characteristics over recommended operating conditions (see Note 3)

	MIN	NOM	MAX	UNIT
$t_{c(C)}$ CLKOUT1, CLKOUT2 cycle time	78.13		597	ns
$t_{d(CIH-C)}$ CLKIN high to CLKOUT1, CLKOUT2, $\overline{\text{STRB}}$ high, low	12		27	ns
$t_{f(C)}$ CLKOUT1, CLKOUT2, $\overline{\text{STRB}}$ fall time			4	ns
$t_{r(C)}$ CLKOUT1, CLKOUT2, $\overline{\text{STRB}}$ rise time			4	ns
$t_{w(CL)}$ CLKOUT1, CLKOUT2, $\overline{\text{STRB}}$ low pulse duration	$2Q - 7$		$2Q + 3$	ns
$t_{w(CH)}$ CLKOUT1, CLKOUT2, $\overline{\text{STRB}}$ high pulse duration	$2Q - 3$		$2Q + 7$	ns
$t_{d(C1-C2)}$ CLKOUT1 high to CLKOUT2 low, CLKOUT2 high to CLKOUT1 high, etc.	$Q - 6$		$Q + 2$	ns

NOTE 3:  $Q = 1/4 t_{c(C)}$

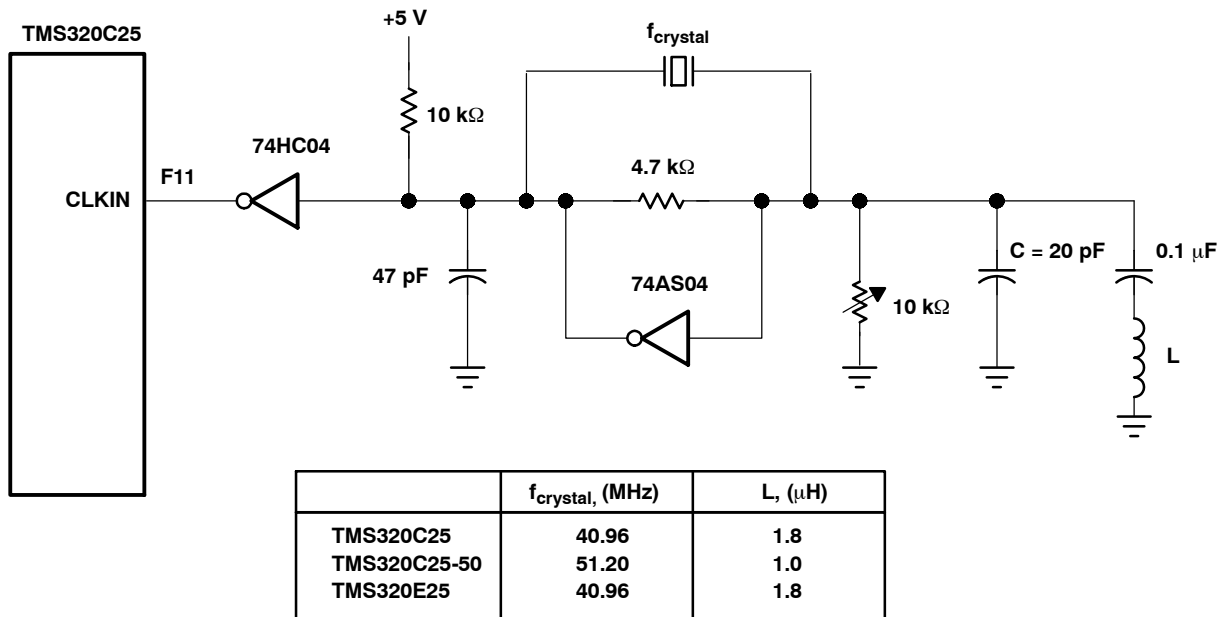

Figure 7. External Clock Option

timing requirements over recommended operating conditions (see Note 3)

		MIN	NOM	MAX	UNIT
$t_{c(\text{Cl})}$	CLKIN cycle time	19.5 3		150	ns
$t_{f(\text{Cl})}$	CLKIN fall time			5 <sup>†</sup>	ns
$t_{r(\text{Cl})}$	CLKIN rise time			5 <sup>†</sup>	ns
$t_{w(\text{ClL})}$	CLKIN low pulse duration, $t_{c(\text{Cl})} = 50$ ns (see Note 4)	20			ns
$t_{w(\text{ClH})}$	CLKIN high pulse duration, $t_{c(\text{Cl})} = 50$ ns (see Note 4)	20			ns
$t_{su(\text{S})}$	$\overline{\text{SYNC}}$ setup time before CLKIN low	4	Q - 4		ns
$t_{h(\text{S})}$	$\overline{\text{SYNC}}$ hold time from CLKIN low	4			ns

<sup>†</sup> Value derived from characterization data and not tested.

NOTES: 3.  $Q = 1/4 t_{c(\text{Cl})}$

4. CLKIN duty cycle  $[t_{r(\text{Cl})} + t_{w(\text{ClH})}]/t_{c(\text{Cl})}$  must be within 40-60%.

ADVANCE INFORMATION

## MEMORY AND PERIPHERAL INTERFACE TIMING

### switching characteristics over recommended operating conditions (see Note 3)

PARAMETER		MIN	TYP	MAX	UNIT
$t_{d(C1-S)}$	$\overline{STRB}$ from CLKOUT (if $\overline{STRB}$ is present)	Q - 5		Q + 3	ns
$t_{d(C2-S)}$	CLKOUT2 to $\overline{STRB}$ (if $\overline{STRB}$ is present)	- 2		5	ns
$t_{su(A)}$	Address setup time before $\overline{STRB}$ low (see Note 5)	Q - 11			ns
$t_{h(A)}$	Address hold time after $\overline{STRB}$ high (see Note 5)	Q - 4			ns
$t_{w(SL)}$	$\overline{STRB}$ low pulse duration (no wait states, see Note 6)	2Q - 5		2Q + 2	ns
$t_{w(SH)}$	$\overline{STRB}$ high pulse duration (between consecutive cycles, see Note 6)	2Q - 2		2Q + 5 <sup>†</sup>	ns
$t_{su(D)W}$	Data write setup time before $\overline{STRB}$ high (no wait)	2Q - 17			ns
$t_{h(D)W}$	Data write hold time from $\overline{STRB}$ high	Q - 5			ns
$t_{en(D)}$	Data bus starts being driven after $\overline{STRB}$ low (write)	0 <sup>†</sup>			ns
$t_{dis(D)}$	Data bus high-impedance state after $\overline{STRB}$ high, (write)		Q	Q + 15 <sup>†</sup>	ns
$t_{d(MSC)}$	$\overline{MSC}$ valid from CLKOUT1	-1		9	ns

<sup>†</sup> Value derived from characterization data and not tested.

NOTES: 3.  $Q = 1/4 t_{c(C)}$

5. A15-A0,  $\overline{PS}$ ,  $\overline{DS}$ ,  $\overline{IS}$ ,  $R/\overline{W}$ , and  $\overline{BR}$  timings are all included in timings referenced as "address".

6. Delay between CLKOUT1, CLKOUT2, and  $\overline{STRB}$  edges track each other, resulting in  $t_{w(SL)}$  and  $t_{w(SH)}$  being 2Q with no wait states.

### timing requirements over recommended operating conditions (see Note 3)

		MIN	NOM	MAX	UNIT
$t_{a(A)}$	Read data access time from address time (see Notes 5 and 7)			3Q - 30	ns
$t_{su(D)R}$	Data read setup time before $\overline{STRB}$ high	19			ns
$t_{h(D)R}$	Data read hold time from $\overline{STRB}$ high	0			ns
$t_{d(SL-R)}$	READY valid after $\overline{STRB}$ low (no wait states)			Q - 21	ns
$t_{d(C2H-R)}$	READY valid after CLKOUT2 high			Q - 21	ns
$t_{h(SL-R)}$	READY hold time after $\overline{STRB}$ low (no wait states)	Q - 1			ns
$t_{h(C2H-R)}$	READY valid after CLKOUT2 high	Q - 1			ns
$t_{d(M-R)}$	READY valid after $\overline{MSC}$ valid			2Q - 24	ns
$t_{h(M-R)}$	READY hold time after $\overline{MSC}$ valid	0			ns

NOTES: 3.  $Q = 1/4 t_{c(C)}$

5. A15-A0,  $\overline{PS}$ ,  $\overline{DS}$ ,  $\overline{IS}$ ,  $R/\overline{W}$ , and  $\overline{BR}$  timings are all included in timings referenced as "address".

7. Read data access time is defined as  $t_{a(A)} = t_{su(A)} + t_{w(SL)} - t_{su(D)R}$ .

**RS, INT, BIO, AND XF TIMING****switching characteristics over recommended operating conditions (see Notes 3 and 16)**

PARAMETER		MIN	TYP	MAX	UNIT
$t_{d(RS)}$	CLKOUT1 low to reset state entered			22 <sup>†</sup>	ns
$t_{d(IACK)}$	CLKOUT1 to $\overline{IACK}$ valid	- 5		7	ns
$t_{d(XF)}$	XF valid before falling edge of $\overline{STRB}$	Q - 8			ns

<sup>†</sup> Value derived from characterization data and not tested.

NOTES: 3.  $Q = 1/4 t_{c(C)}$

16.  $RS, INT, BIO$  are asynchronous inputs and can occur at any time during a clock cycle.

**timing requirements over recommended operating conditions (see Notes 3 and 16)**

		MIN	NOM	MAX	UNIT
$t_{su(IN)}$	$INT, BIO, RS$ setup before CLKOUT1 high	25			ns
$t_{h(IN)}$	$INT, BIO, RS$ hold after CLKOUT1 high	0			ns
$t_{f(IN)}$	$INT, BIO$ fall time			8 <sup>†</sup>	ns
$t_{w(IN)}$	$INT, BIO$ low pulse duration	$t_{c(C)}$			ns
$t_{w(RS)}$	$RS$ low pulse duration	$3t_{c(C)}$			ns

<sup>†</sup> Value derived from characterization data and not tested.

NOTES: 3.  $Q = 1/4 t_{c(C)}$

16.  $RS, INT, BIO$  are asynchronous inputs and can occur at any time during a clock cycle.

**HOLD TIMING****switching characteristics over recommended operating conditions (see Note 3)**

PARAMETER		MIN	TYP	MAX	UNIT
$t_{d(CIL-AL)}$	$HOLD\overline{A}$ low after CLKOUT1 low	1 <sup>†</sup>		11	ns
$t_{dis(AL-A)}$	$HOLD\overline{A}$ low to address high-impedance		0 <sup>†</sup>		ns
$t_{dis(CIL-A)}$	Address high-impedance after CLKOUT1 low ( $HOLD$ mode, see Note 17)			20 <sup>†</sup>	ns
$t_{d(HH-AH)}$	$HOLD$ high to $HOLD\overline{A}$ high			19	ns
$t_{en(A-CIL)}$	Address driven before CLKOUT1 low ( $HOLD$ mode, see Note 17)			8 <sup>†</sup>	ns

<sup>†</sup> Value derived from characterization data and not tested.

NOTES: 3.  $Q = 1/4 t_{c(C)}$

17. A15-A0,  $\overline{PS}, \overline{DS}, \overline{STRB}$ , and  $R/\overline{W}$  timings are all included in timings referenced as "address".

**timing requirements over recommended operating conditions (see Note 3)**

		MIN	NOM	MAX	UNIT
$\overline{t}_{d(C2H-H)}$	$HOLD$ valid after CLKOUT2 high		Q - 19		ns

NOTE 3:  $Q = 1/4 t_{c(C)}$

ADVANCE INFORMATION

## SERIAL PORT TIMING

## switching characteristics over recommended operating conditions (see Note 3)

PARAMETER		MIN	TYP	MAX	UNIT
$t_{d(CH-DX)}$	DX valid after CLKX rising edge (see Note 18)			75	ns
$t_{d(FL-DX)}$	DX valid after falling edge (TXM = 0, see Note 18)			40	ns
$t_{d(CH-FS)}$	FSX valid after CLKX raising edge (TXM = 1)			40	ns

NOTES: 3.  $Q = 1/4 t_{c(C)}$ 

18. The last occurrence of FSX falling and CLKX rising.

## timing requirements over recommended operating conditions (see Note 3)

		MIN	NOM	MAX	UNIT
$t_{c(SCK)}$	Serial port clock (CLKX/CLKR) cycle time <sup>†</sup>	160			ns
$t_{f(SCK)}$	Serial port clock (CLKX/CLKR) fall time			25 <sup>‡</sup>	ns
$t_{r(SCK)}$	Serial port clock (CLKX/CLKR) rise time			25 <sup>‡</sup>	ns
$t_{w(SCK)}$	Serial port clock (CLKX/CLKR) low or high pulse duration (see Note 19)	64			ns
$t_{su(FS)}$	FSX or FSR setup time before CLKX, CLKR falling edge (TXM = 0)	5			ns
$t_{h(FS)}$	FSX or FSR hold time before CLKX, CLKR falling edge (TXM = 0)	10			ns
$t_{su(DR)}$	DR setup time before CLKR falling edge	5			ns
$t_{h(DR)}$	DR hold time after CLKR falling edge	10			ns

<sup>†</sup> The serial port was tested at a minimum frequency of 1.25 MHz. However, the serial port was fully static but will properly function down to  $f_{sx} = 0$  Hz.<sup>‡</sup> Value derived from characterization data and not tested.NOTES: 3.  $Q = 1/4 t_{c(C)}$ 

19. The cycle of the serial port must be within 40%-60%.

## CONTRAST SUMMARY OF ELECTRICAL SPECIFICATIONS

The following table presents electrical parameters which differ between TMS320C25 (40 MHz, 100 ns) and TMS320C25-50 (50 MHz, 80 ns).

## clock characteristics and timing

PARAMETER	TMS320C25			TMS320C25-50			UNIT
	MIN	TYP	MAX	MIN	TYP	MAX	
$t_{c(SCK)}$	97.7		597	78.13		597	ns
$t_{d(CIH-C)}$	5		30	12		27	ns
$t_{f(C)}$			5			4	ns
$t_{r(C)}$			5			4	ns
$t_{w(CL)}$	2Q - 8	2Q	2Q + 8	2Q - 7		2Q + 3	ns
$t_{w(CH)}$	2Q - 8	2Q	2Q + 8	2Q - 3		2Q + 7	ns
$t_{d(C1-C2)}$	Q - 5	Q	Q + 5	Q - 6		Q + 2	ns
$t_{su(S)}$	5		Q - 5	4		Q - 4	ns
$t_{h(S)}$	8			4			ns

memory and peripheral interface timing

PARAMETER	TMS320C25			TMS320C25-50			UNIT
	MIN	TYP	MAX	MIN	TYP	MAX	
t <sub>d</sub> (C1-S)	Q - 6	Q	Q+6	Q - 5		Q + 3	ns
t <sub>d</sub> (C2-S)	- 6	0	6	- 2		5	ns
t <sub>su</sub> (A)	Q - 12			Q - 11			ns
t <sub>h</sub> (A)	Q - 8			Q - 4			ns
t <sub>w</sub> (SL)		2Q		2Q - 5	2Q + 2		ns
t <sub>w</sub> (SH)		2Q		2Q - 2	2Q + 5		ns
t <sub>su</sub> (D)W	2Q - 20			2Q - 17			ns
t <sub>h</sub> (D)W	Q - 10	Q		Q - 5			ns
t <sub>d</sub> (MSC)	- 12	0	12	-1		9	ns
t <sub>a</sub> (A)		3Q - 35		3Q - 30			ns
t <sub>su</sub> (D)R	23			19			ns
t <sub>h</sub> (D)R	0			0			ns
t <sub>d</sub> (SL-R)		Q - 20		Q - 21			ns
t <sub>d</sub> (C2H-R)		Q - 20		Q - 21			ns
t <sub>h</sub> (SL-R)	Q + 3			Q - 1			ns
t <sub>h</sub> (C2H-R)	Q + 3			Q - 1			ns
t <sub>d</sub> (M-R)		2Q - 25		2Q - 24			ns
t <sub>h</sub> (M-R)	0			0			ns

RS, INT, BIO, and XF timing

PARAMETER	TMS320C25			TMS320C25-50			UNIT
	MIN	TYP	MAX	MIN	TYP	MAX	
t <sub>d</sub> (IACK)	- 6	0	12	- 5		7	ns
t <sub>d</sub> (XF)	Q - 15			Q - 8			ns
t <sub>su</sub> (IN)	32			25			ns
t <sub>h</sub> (IN)	0			0			ns

HOLD timing

PARAMETER	TMS320C25			TMS320C25-50			UNIT
	MIN	TYP	MAX	MIN	TYP	MAX	
t <sub>d</sub> (C1L-AL)	0		10	1		11	ns
t <sub>d</sub> (HH-AH)			25			19	ns
t <sub>d</sub> (C2H-H)			Q - 24			Q - 19	ns

serial port timing

PARAMETER	TMS320C25			TMS320C25-50			UNIT
	MIN	TYP	MAX	MIN	TYP	MAX	
t <sub>d</sub> (CH-DX)			75			70	ns
t <sub>d</sub> (FL-DX)			40			40	ns
t <sub>d</sub> (CH-FS)			40			40	ns
t <sub>su</sub> (FS)	18			5			ns
t <sub>h</sub> (FS)	20			10			ns
t <sub>su</sub> (DR)	10			5			ns
t <sub>h</sub> (DR)	20			10			ns

ADVANCE INFORMATION





TIMING DIAGRAMS

This section contains all the timing diagrams for the TMS320 second-generation devices. Refer to the top corner of page for the specific device.

Timing measurements are referenced to and from a low voltage of 0.8 voltage and a high voltage of 2 volts, unless otherwise noted.

clock timing

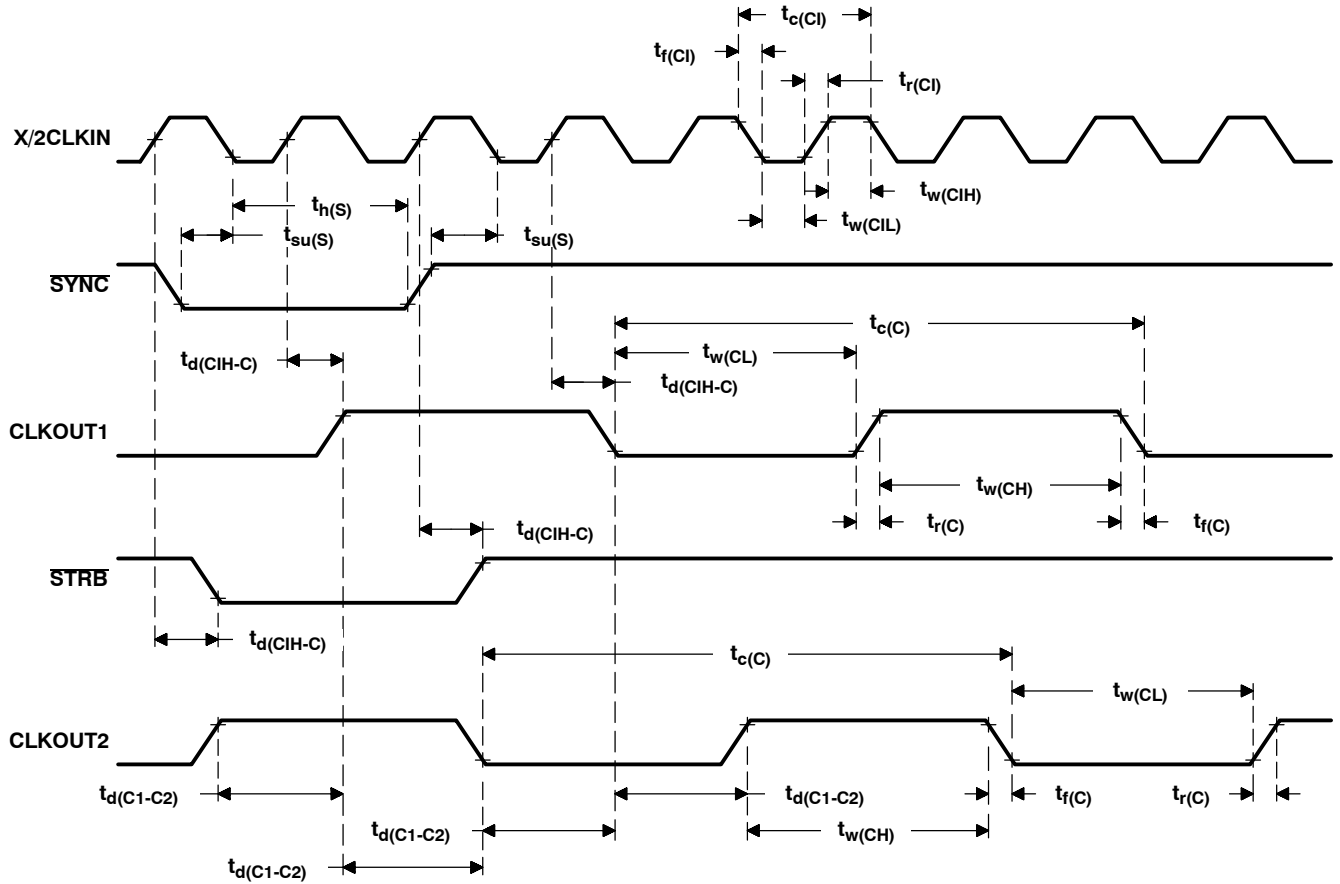

ADVANCE INFORMATION

# TMS320 SECOND GENERATION DEVICES

SPRS010B — MAY 1987 — REVISED NOVEMBER 1990

## memory read timing

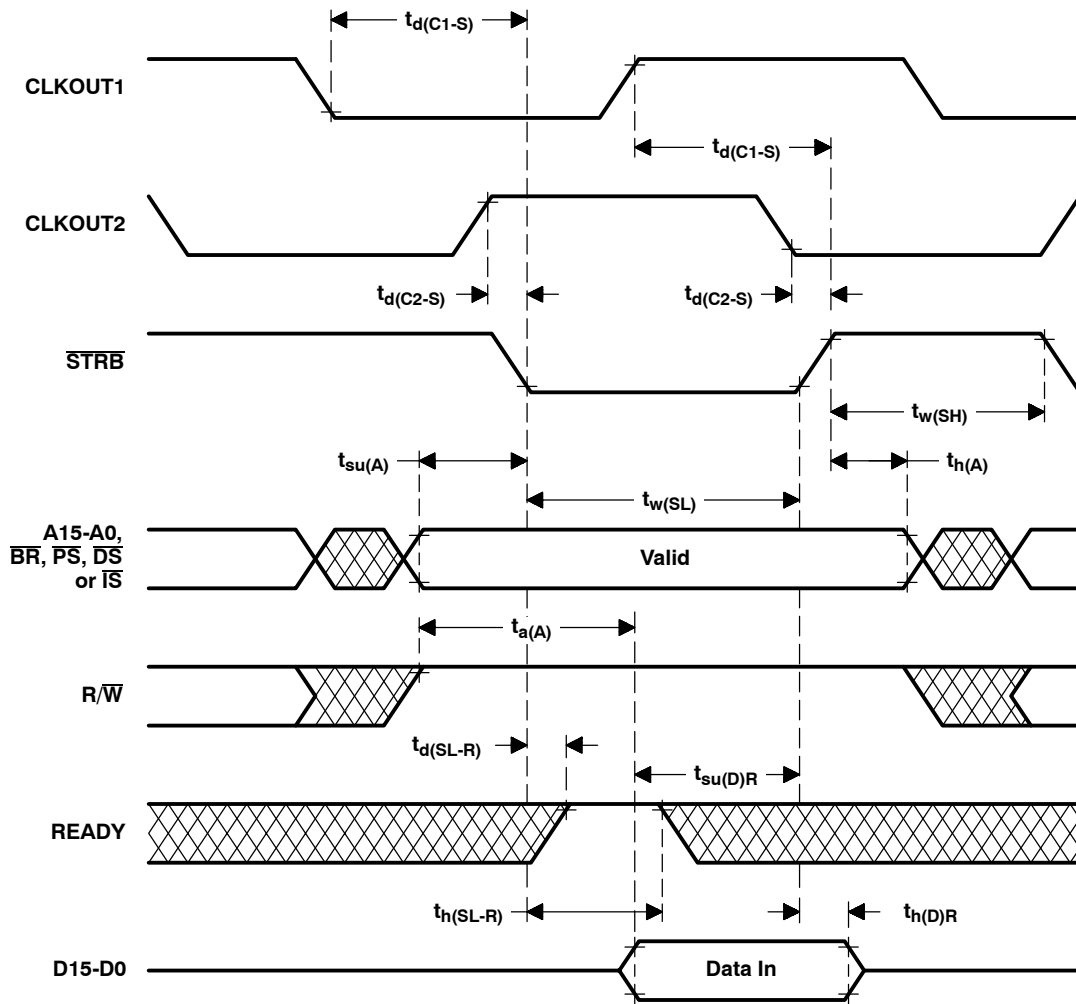

ADVANCE INFORMATION

memory write timing

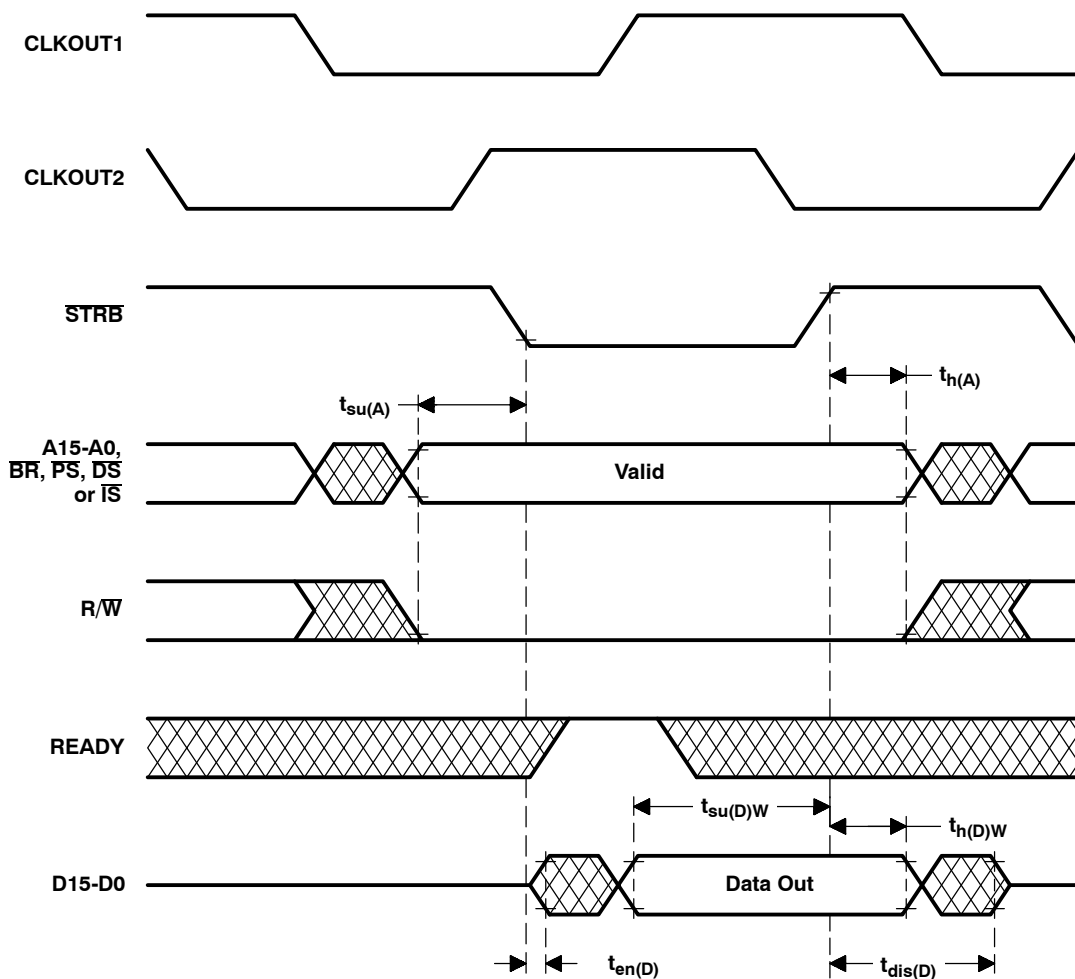

ADVANCE INFORMATION

# TMS320 SECOND GENERATION DEVICES

SPRS010B — MAY 1987 — REVISED NOVEMBER 1990

## one wait-state memory access timing

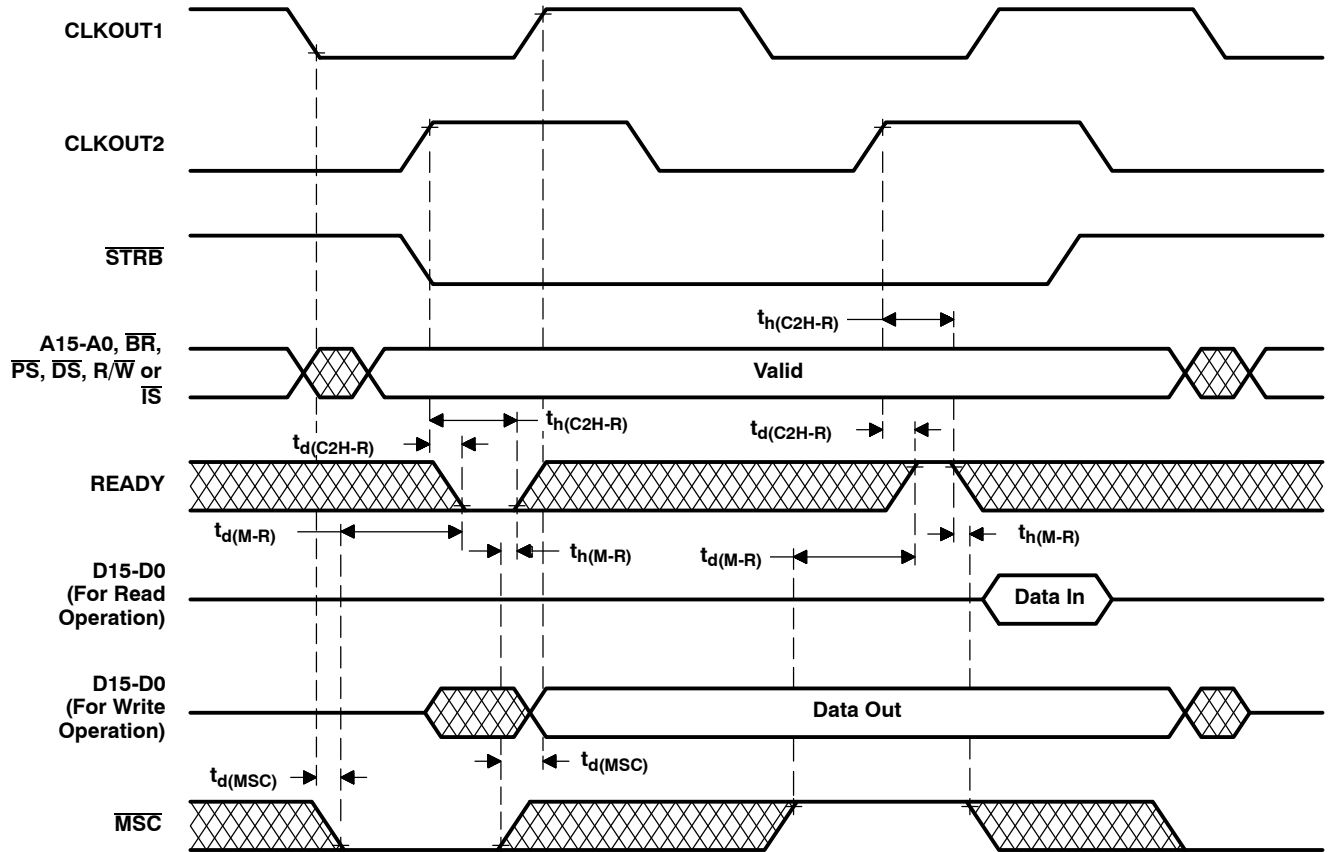

ADVANCE INFORMATION

reset timing

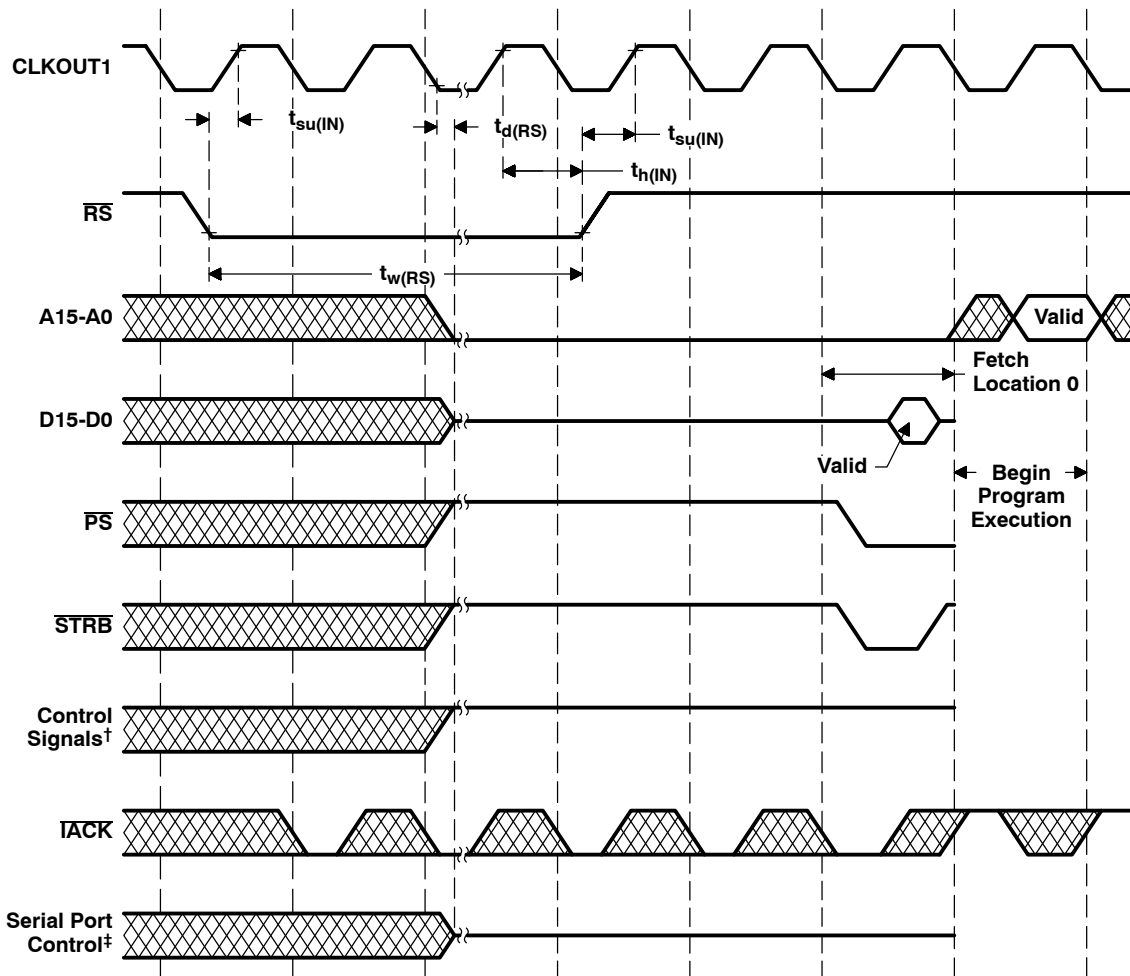

† Control signals are  $\overline{DS}$ ,  $\overline{IS}$ , R/W, and XF.

‡ Serial port controls are DX and FSX.

ADVANCE INFORMATION

# TMS320 SECOND GENERATION DEVICES

SPRS010B — MAY 1987 — REVISED NOVEMBER 1990

## interrupt timing (TMS32020)

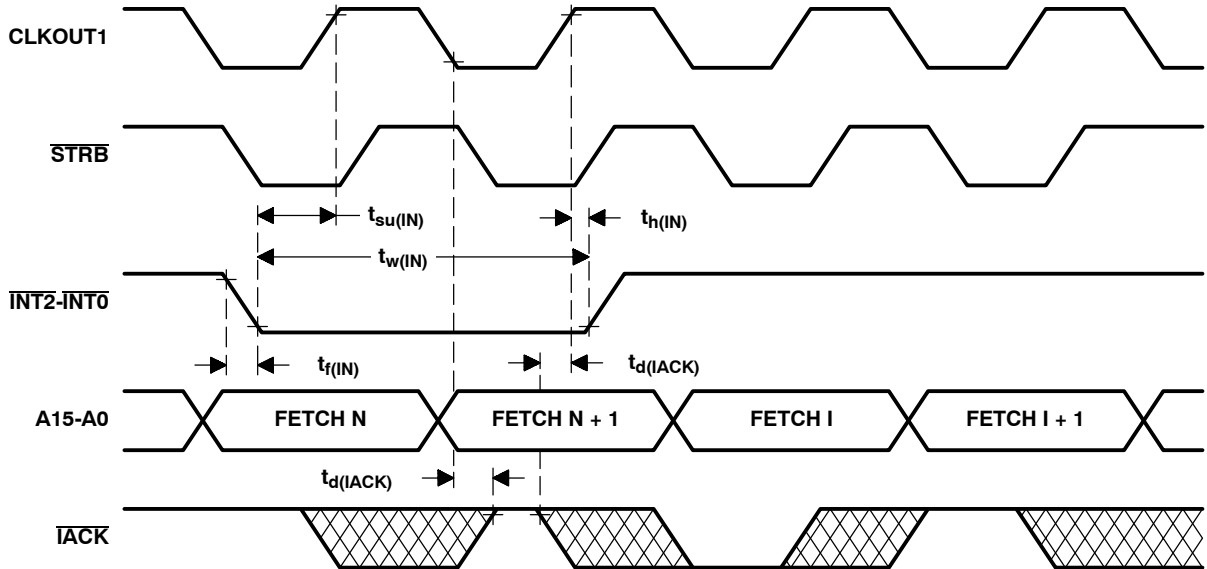

ADVANCE INFORMATION

## interrupt timing (TMS320C25)

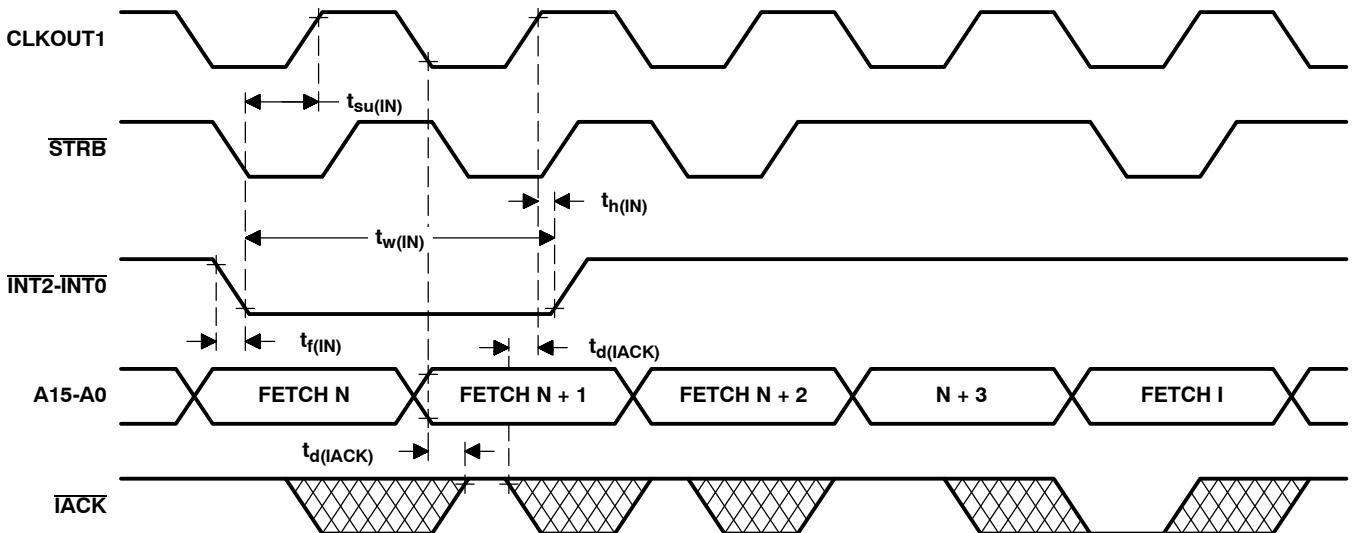

serial port receive timing

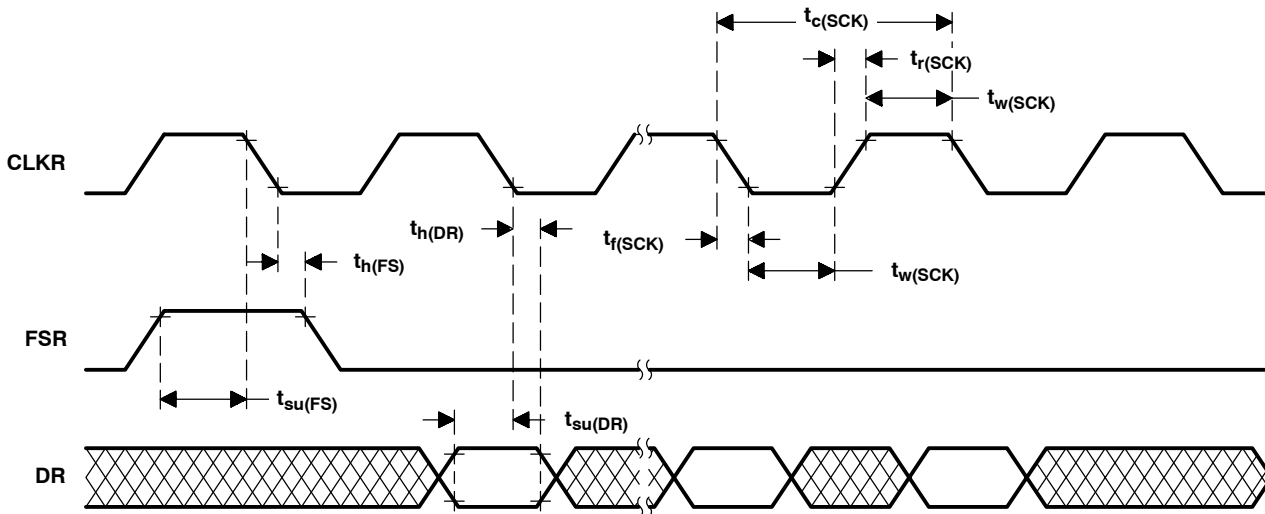

serial port transmit timing

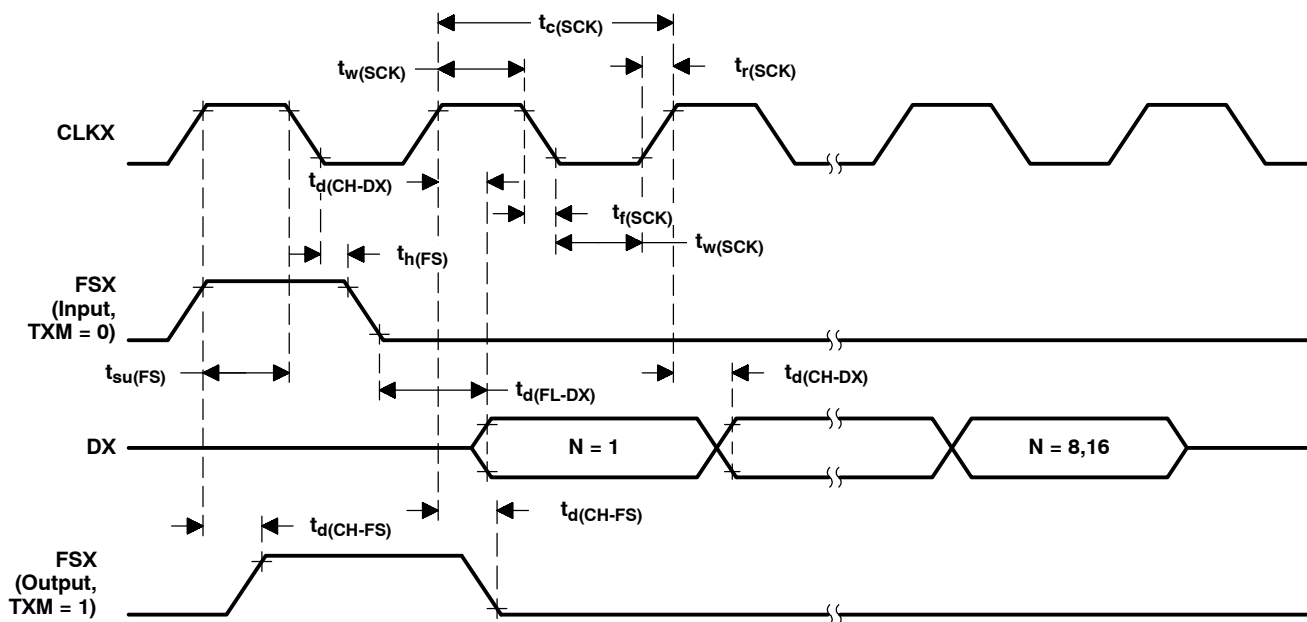

ADVANCE INFORMATION

**BIO timing**

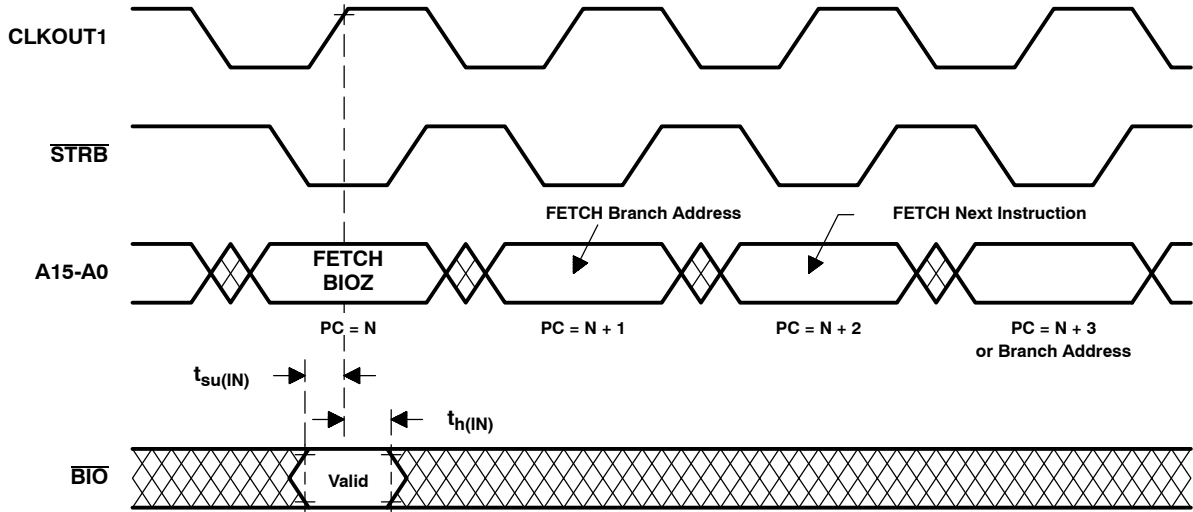

**external flag timing**

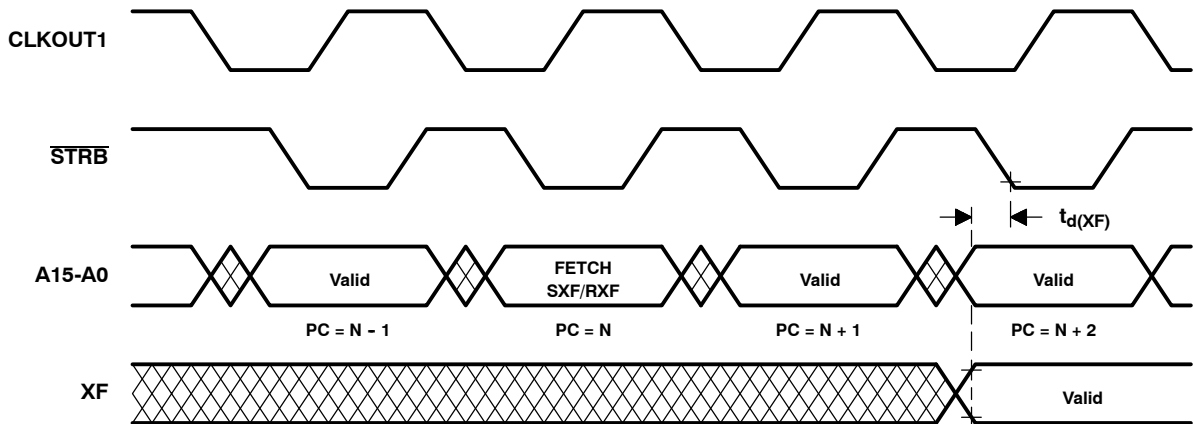

ADVANCE INFORMATION



**BIO timing**

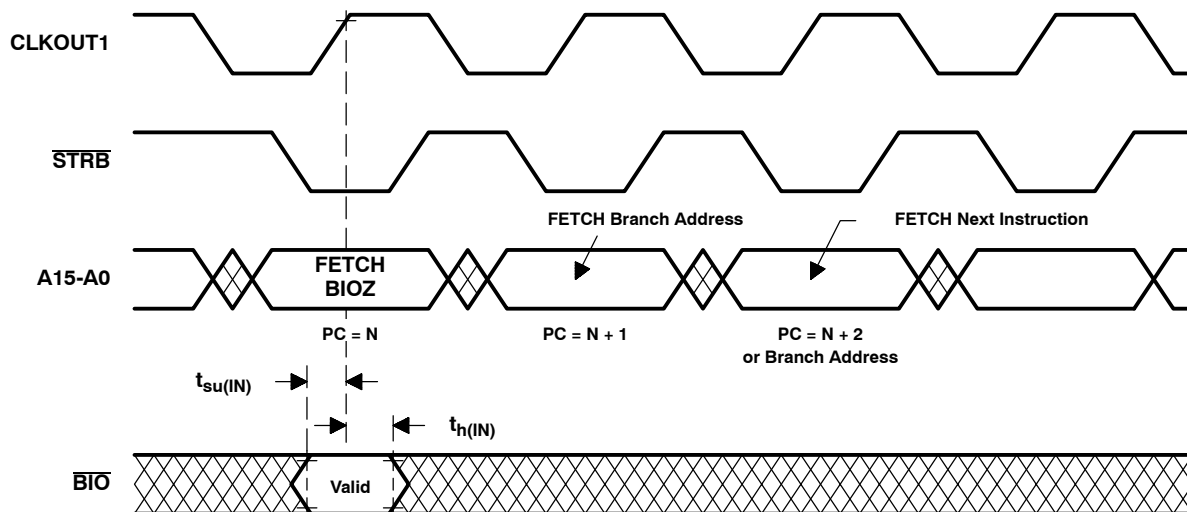

**external flag timing**

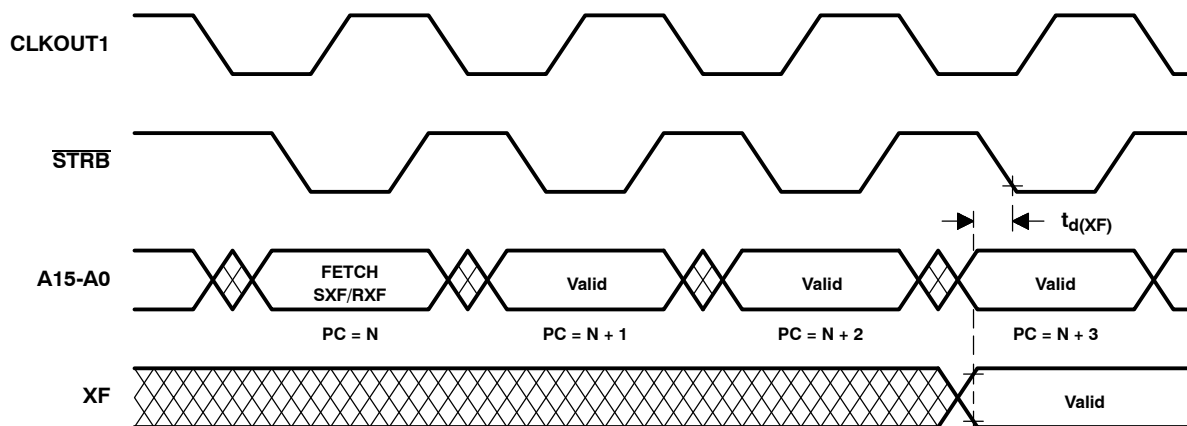

ADVANCE INFORMATION

**HOLD timing (part A)**

**ADVANCE INFORMATION**

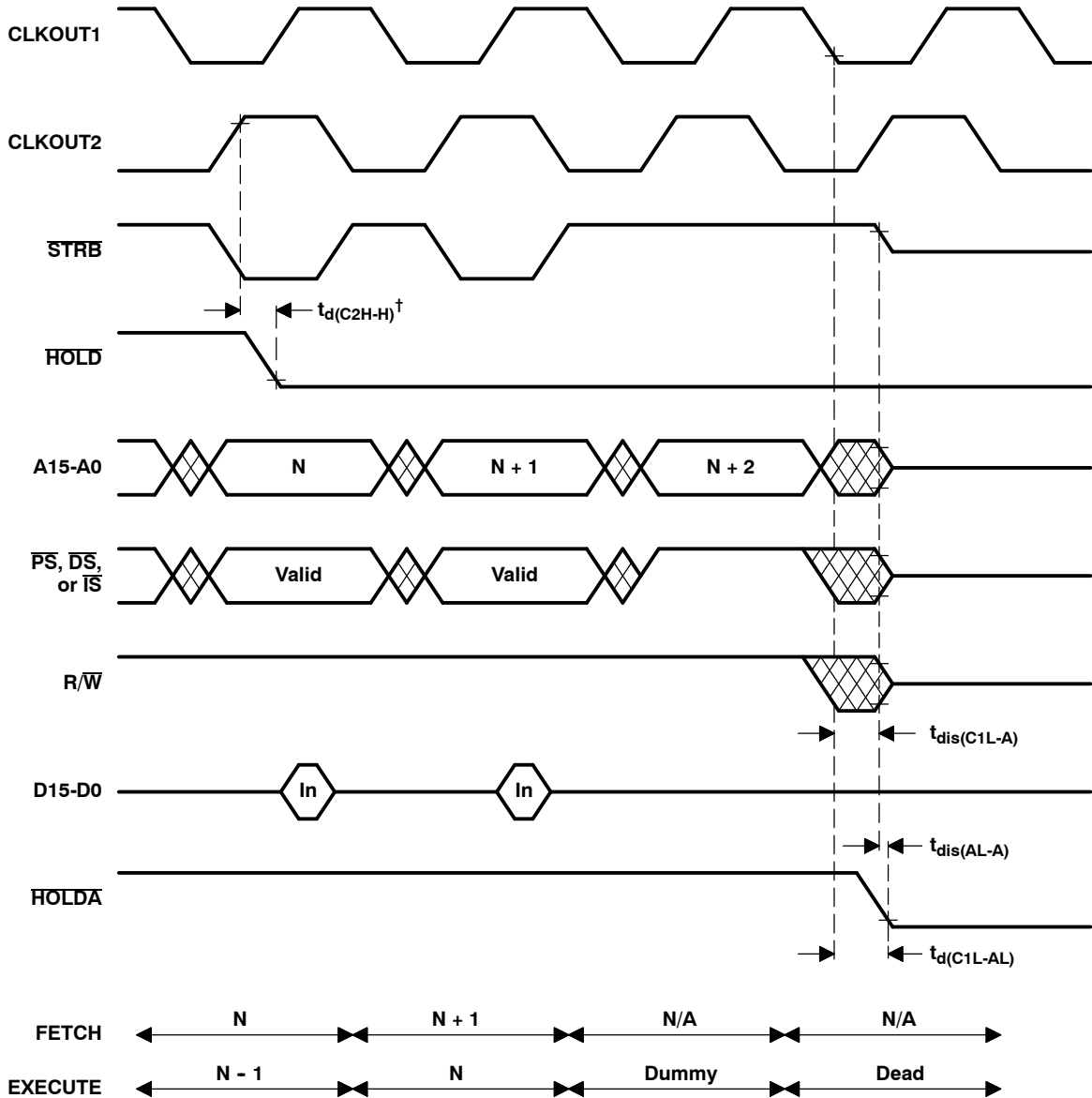

$^\dagger$   $\overline{\text{HOLD}}$  is an asynchronous input and can occur at any time during a clock cycle. If the specified timing is met, the exact sequence shown will occur; otherwise, a delay of one CLKOUT2 cycle will occur.

**HOLD timing (part B)**

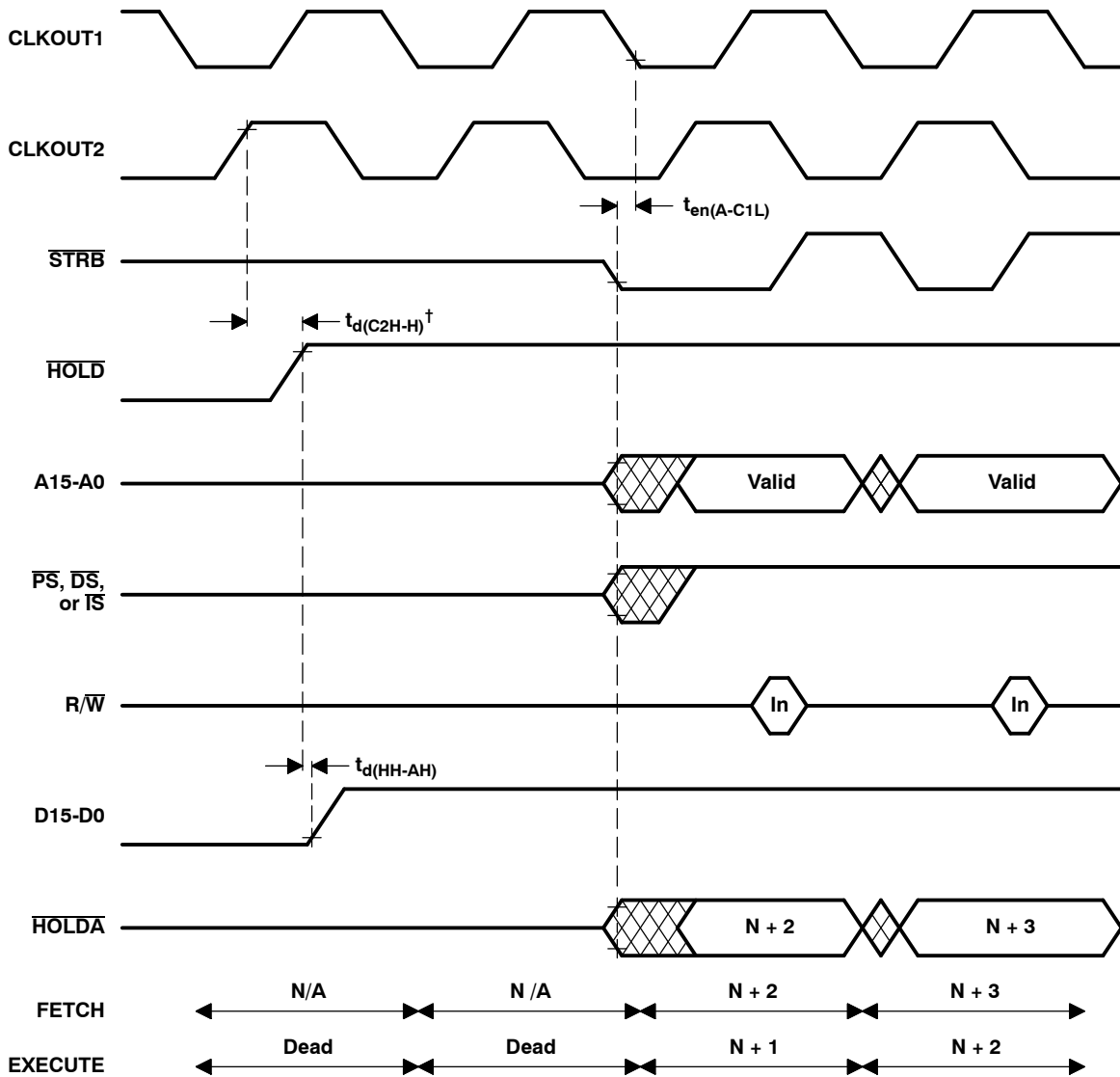

ADVANCE INFORMATION

† HOLD is an asynchronous input and can occur at any time during a clock cycle. If the specified timing is met, the exact sequence shown will occur; otherwise, a delay of one CLKOUT2 cycle will occur.

**HOLD timing (part A)**

**ADVANCE INFORMATION**

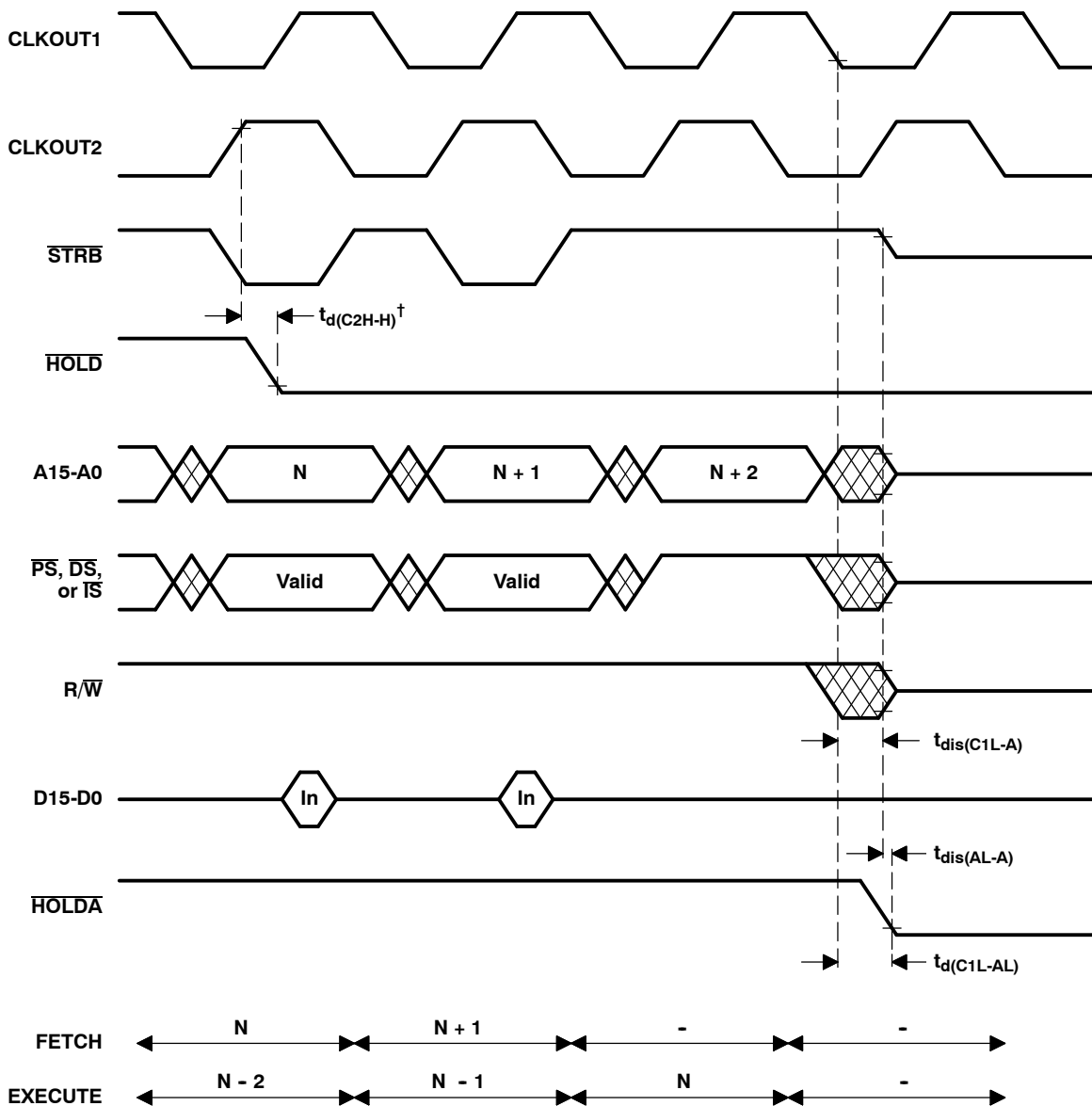

$^{\dagger}$   $\overline{\text{HOLD}}$  is an asynchronous input and can occur at any time during a clock cycle. If the specified timing is met, the exact sequence shown will occur; otherwise, a delay of one CLKOUT2 cycle will occur.

**HOLD timing (part B)**

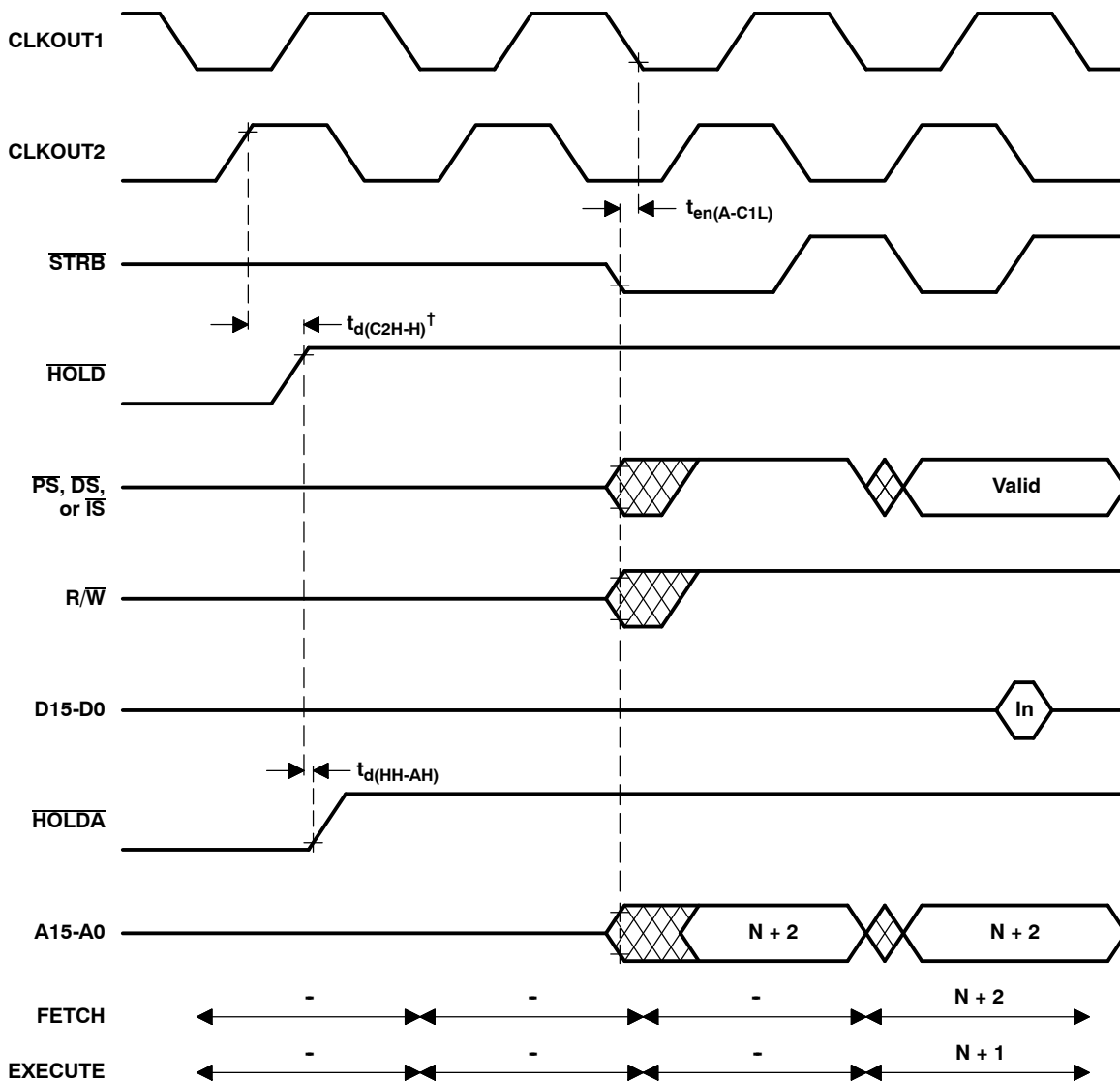

ADVANCE INFORMATION

† HOLD is an asynchronous input and can occur at any time during a clock cycle. If the specified timing is met, the exact sequence shown will occur; otherwise, a delay of one CLKOUT2 cycle will occur.

# TMS320 SECOND GENERATION DEVICES

SPRS010B — MAY 1987 — REVISED NOVEMBER 1990

## TYPICAL SUPPLY CURRENT CHARACTERISTICS FOR TMS320C25

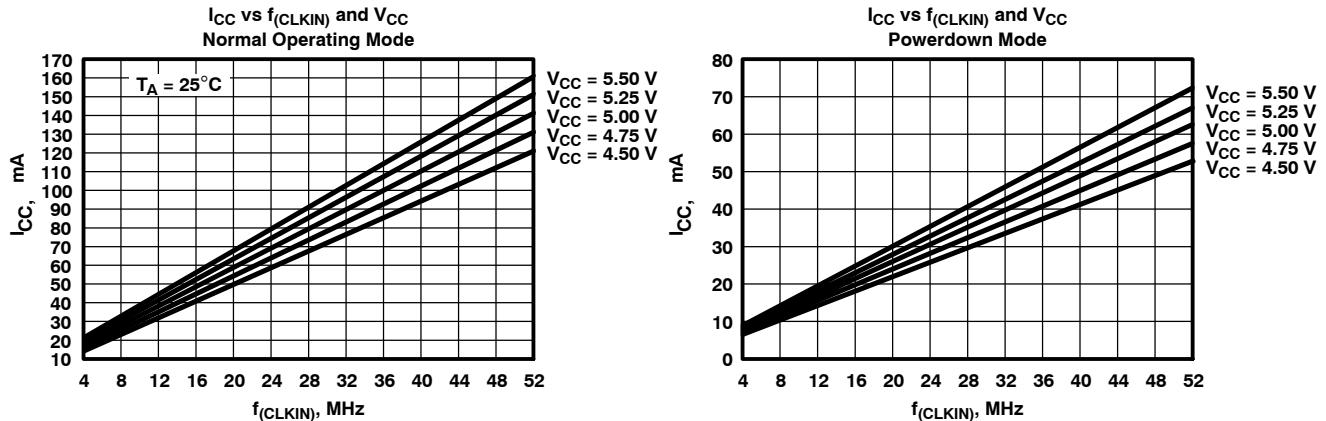

### TMS320C25FNL (PLCC) reflow soldering precautions

Recent tests have identified an industry-wide problem experienced by surface mounted devices exposed to reflow soldering temperatures. This problem involves a package cracking phenomenon sometimes experienced by large (e.g., 68-lead) plastic leaded chip carrier (PLCC) packages during surface mount manufacturing. This phenomenon occurs if the TMS320C25FNL is exposed to uncontrolled levels of humidity prior to reflow solder. This moisture can flash to steam during solder reflow, causing sufficient stress to crack the package and compromise device integrity. If the TMS320C25FNL is being socketed, *no* special handling precautions are required. In addition, once the device is soldered into the board, *no* special handling precautions are required.

In order to minimize moisture absorption, TI ships the TMS320C25FNL in "dry pack" shipping bags with a RH indicator card and moisture-absorbing desiccant. These moisture-barrier shipping bags will adequately block moisture transmission to allow shelf storage for 12 months from date of seal when stored at less than 60% relative humidity (RH) and less than 30°C. Devices may be stored outside the sealed bags indefinitely if stored at less than 25% RH and 30°C.

Once the bag seal is broken, the devices should be stored at less than 60% RH and 30°C as well as reflow soldered within two days of removal. In the event that either of the above conditions is not met, TI recommends these devices be baked in a clean oven at 125°C and 10% maximum RH for 24 hours. This restores the devices to their "dry packed" moisture level.

#### NOTE

Shipping tubes will not withstand the 125°C baking process. Devices should be transferred to a metal tray or tube before baking. Standard ESD precautions should be followed.

In addition, TI recommends that the reflow process not exceed two solder cycles and the temperature not exceed 220°C.

If you have any additional questions or concerns, please contact your local TI representative.

ADVANCE INFORMATION



MECHANICAL DATA

68-pin GB grid array ceramic package (TMS32020, TMS320C25)

Thermal Resistance Characteristics

PARAMETER		MAX	UNIT
R <sub>θJA</sub>	Junction-to-free-air thermal resistance	36	°C/W
R <sub>θJC</sub>	Junction-to-case thermal resistance	6	°C/W

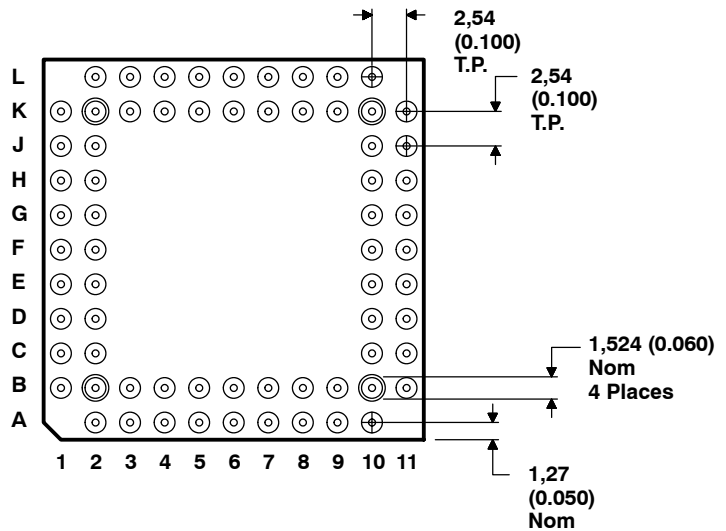
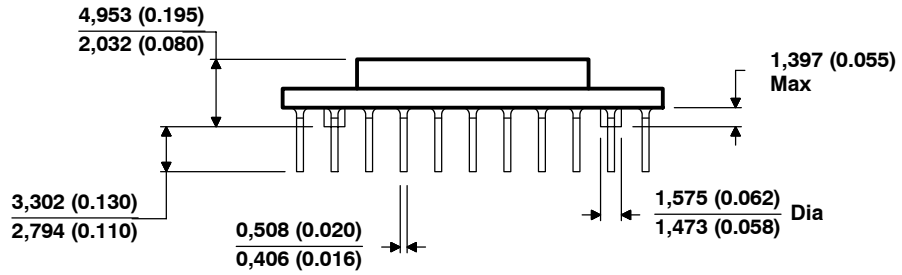
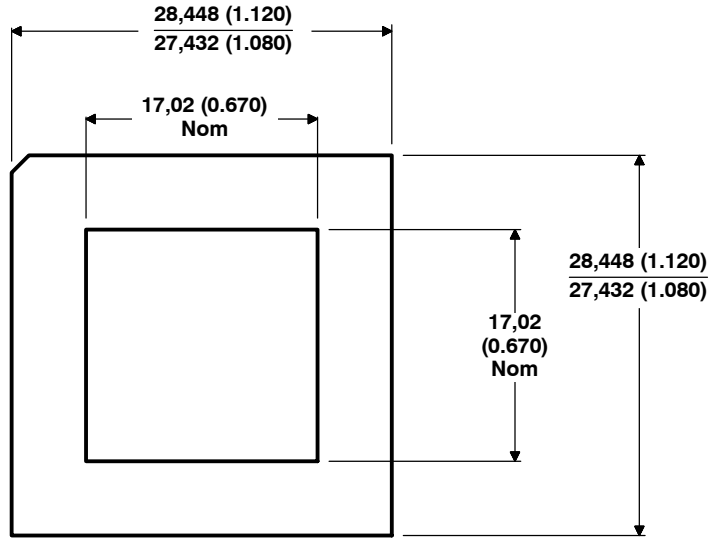

ALL LINEAR DIMENSIONS ARE IN MILLIMETERS AND PARENTHETICALLY IN INCHES

ADVANCE INFORMATION

**TMS320C25**  
**TMS320C25-50**

SPRS010B — MAY 1987 — REVISED NOVEMBER 1990

**68-lead plastic leaded chip carrier package (TMS320C25 and TMS320C25-50)**

**ADVANCE INFORMATION**

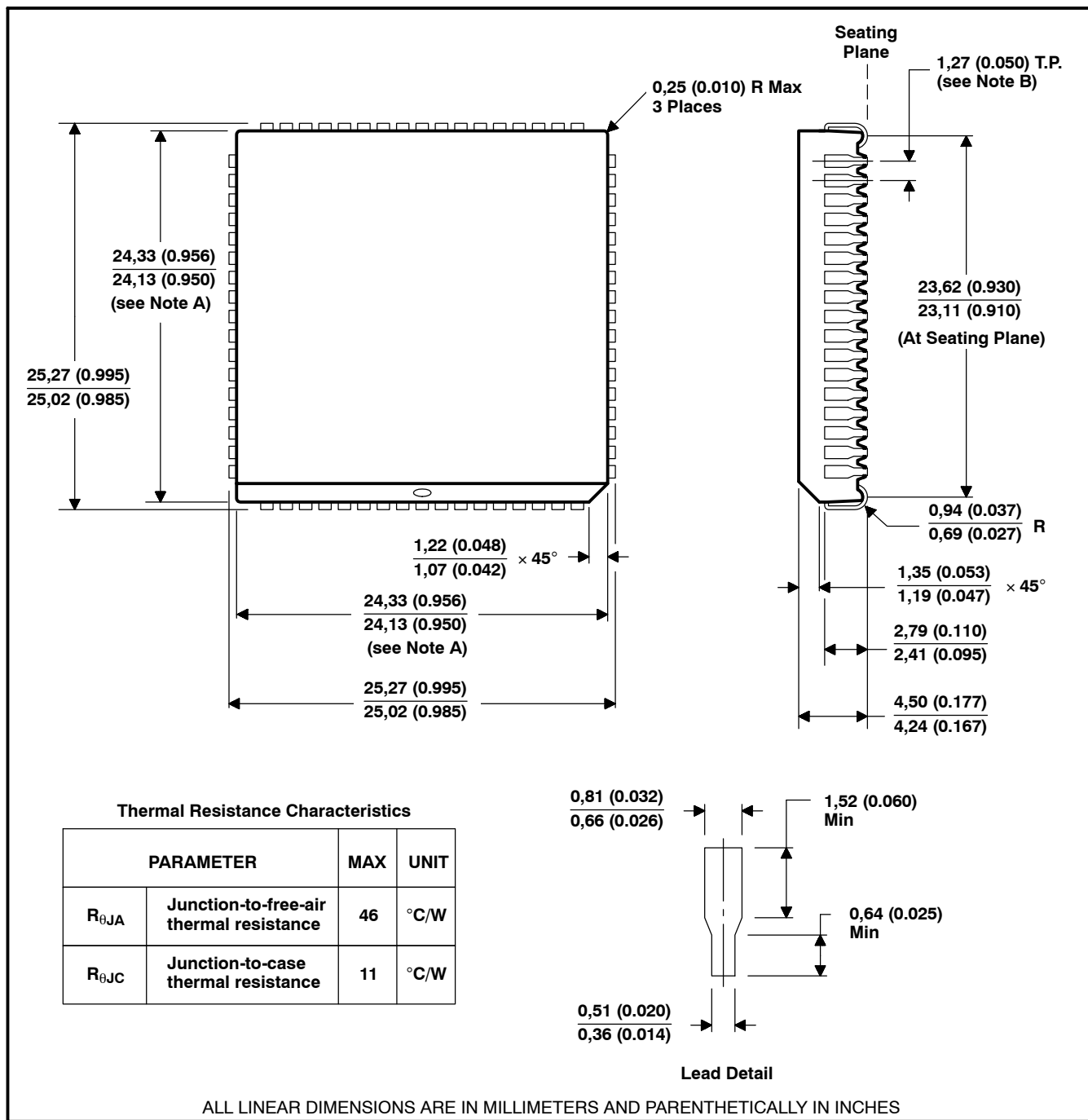

NOTES: A. Centerline of center pin, each side, is within 0,10 (0.004) of package centerline as determined by this dimension.  
 B. Location of each pin is within 0,127 (0.005) of true position with respect to center pin on each side.

**WARNING**  
 When reflow soldering is required, refer to page 54 for special handling instructions.





## MECHANICAL DATA

## 68-lead FZ CER-QUAD, ceramic leaded chip carrier package (TMS320E25 only)

This hermetically-sealed chip carrier package consists of a ceramic base, ceramic cap, and a 68-lead frame. Hermetic sealing is accomplished with glass. The FZ package is intended for both socket- or surface- mounting. Having a Sn/Pb ratio of 60/40, the tin/lead-coated leads do not require special cleaning or processing when being surface-mounted.

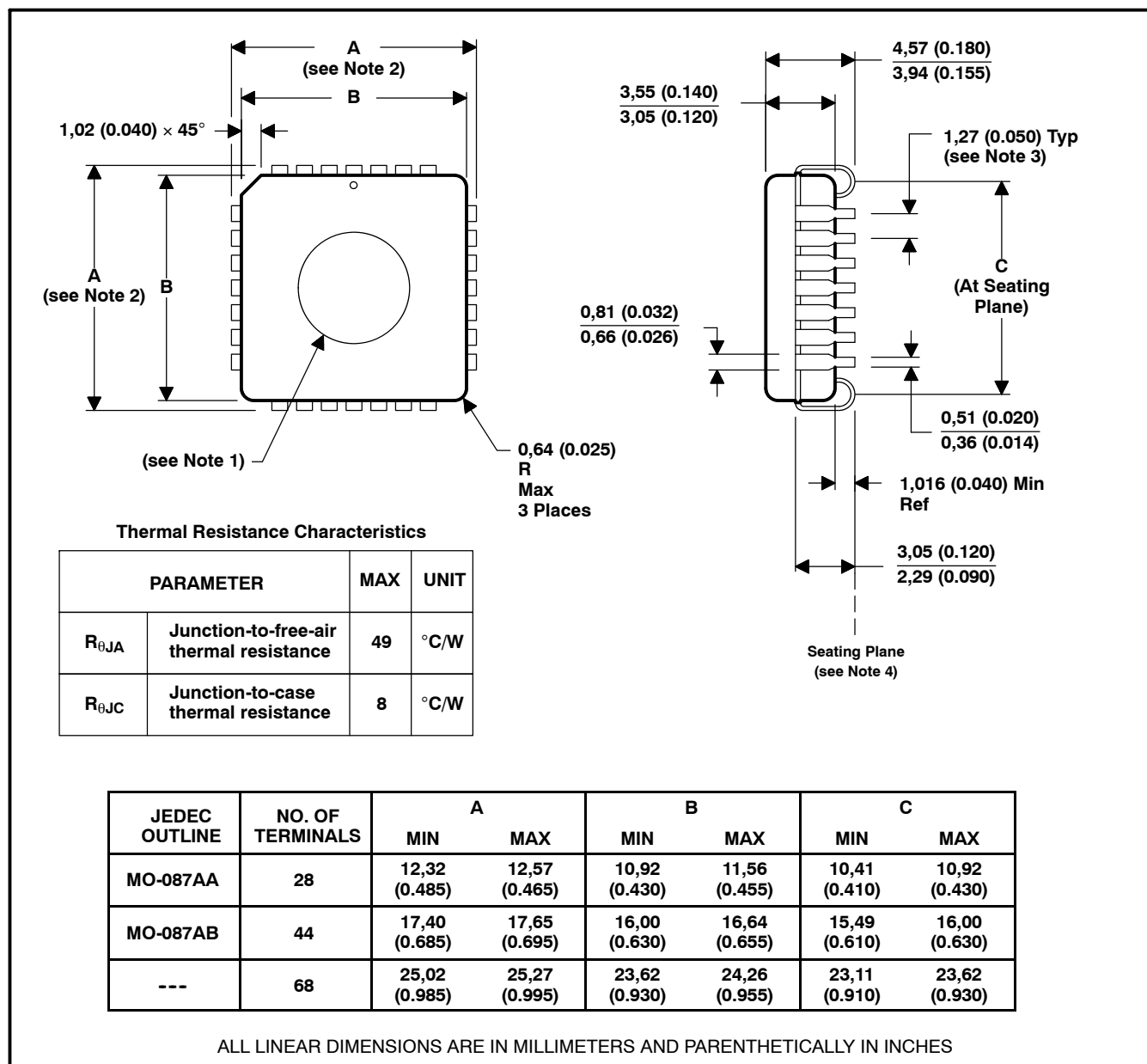

- NOTES: 1. Glass is optional, and the diameter is dependent on device application.  
 2. Centerline of center pin, each side, is within 0,10 (0.004) of package centerline as determined by dimension B.  
 3. Location of each pin is within 0,127 (0.005) of true position with respect to center pin on each side.  
 4. The lead contact points are within 0,15 (0.006) of being planar.

ADVANCE INFORMATION

## programming the TMS320E25 EPROM cell

The TMS320E25 includes a 4K × 16-bit EPROM, implemented from an industry-standard EPROM cell, to perform prototyping and early field testing and to achieve low-volume production. When used with a 4K-word masked-ROM TMS320C25, the TMS320E25 yields a high-volume, low-cost production as a result of more migration paths for data. An EPROM adapter socket (part # TMDX3270120), shown in Figure 8, is available to provide 68-pin to 28-pin conversion for programming the TMS320E25.

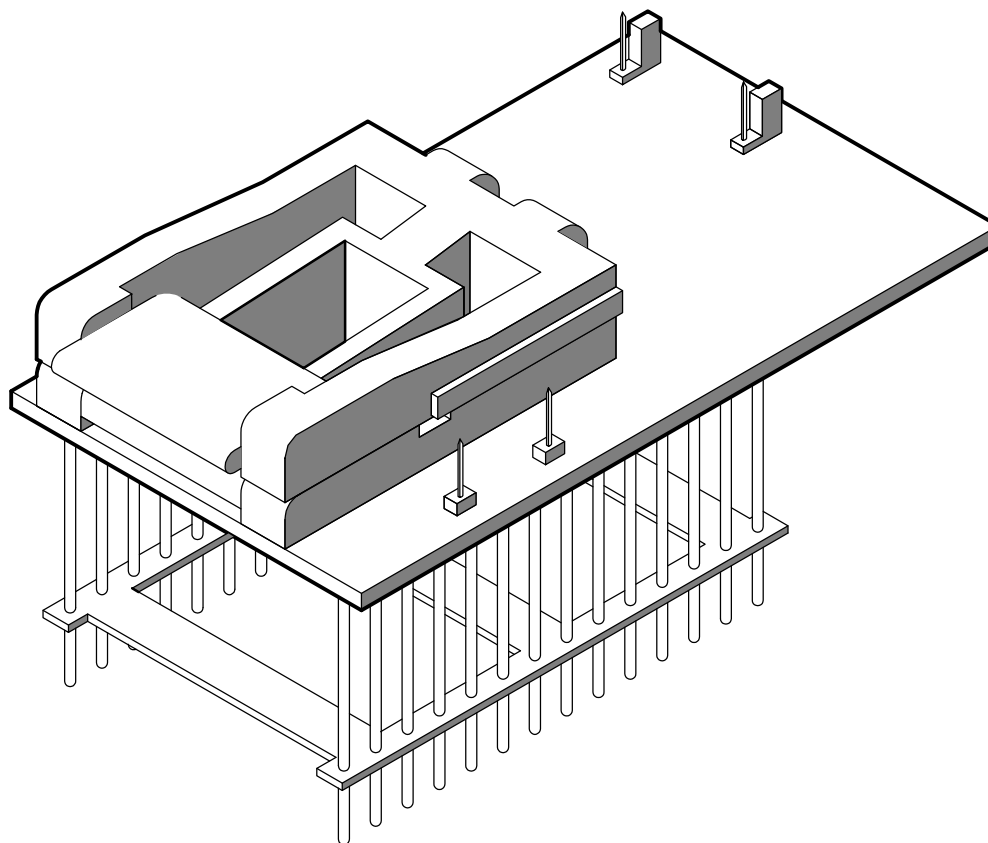

Figure 8. EPROM Adapter Socket

Key features of the EPROM cell include standard programming and verification. For security against copyright violations, the EPROM cell features an internal protection mechanism to prevent proprietary code from being read. The protection feature can be used to protect reading the EPROM contents. This section describes erasure, fast programming and verification, and EPROM protection and verification.

### fast programming and verification

The TMS320E25 EPROM cell is programmed using the same family and device codes as the TMS27C64 8K × 8-bit EPROM. The TMS27C64 EPROM series are ultraviolet-light erasable, electrically programmable read-only memories, fabricated using HVC MOS technology. The TMS27C64 is pin-compatible with existing 28-pin ROMs and EPROMs. The TMS320E25, like the TMS27C64, operates from a single 5-V supply in the read mode; however, a 12.5-V supply is needed for programming. All programming signals are TTL level. For programming outside the system, existing EPROM programmers can be used. Locations may be programmed singly, in blocks, or at random. When programmed in blocks, the data is loaded into the EPROM cell one byte at a time, the high byte first and the low byte second.

Figure 9 shows the wiring conversion to program the TMS320E25 using the 28-pin pinout of the TMS27C64. The pin nomenclature table provides a description of the TMS27C64 pins. The code to be programmed into the device should be serial mode. The TMS320E25 uses 13 address lines to address the 4K-word memory in byte format.

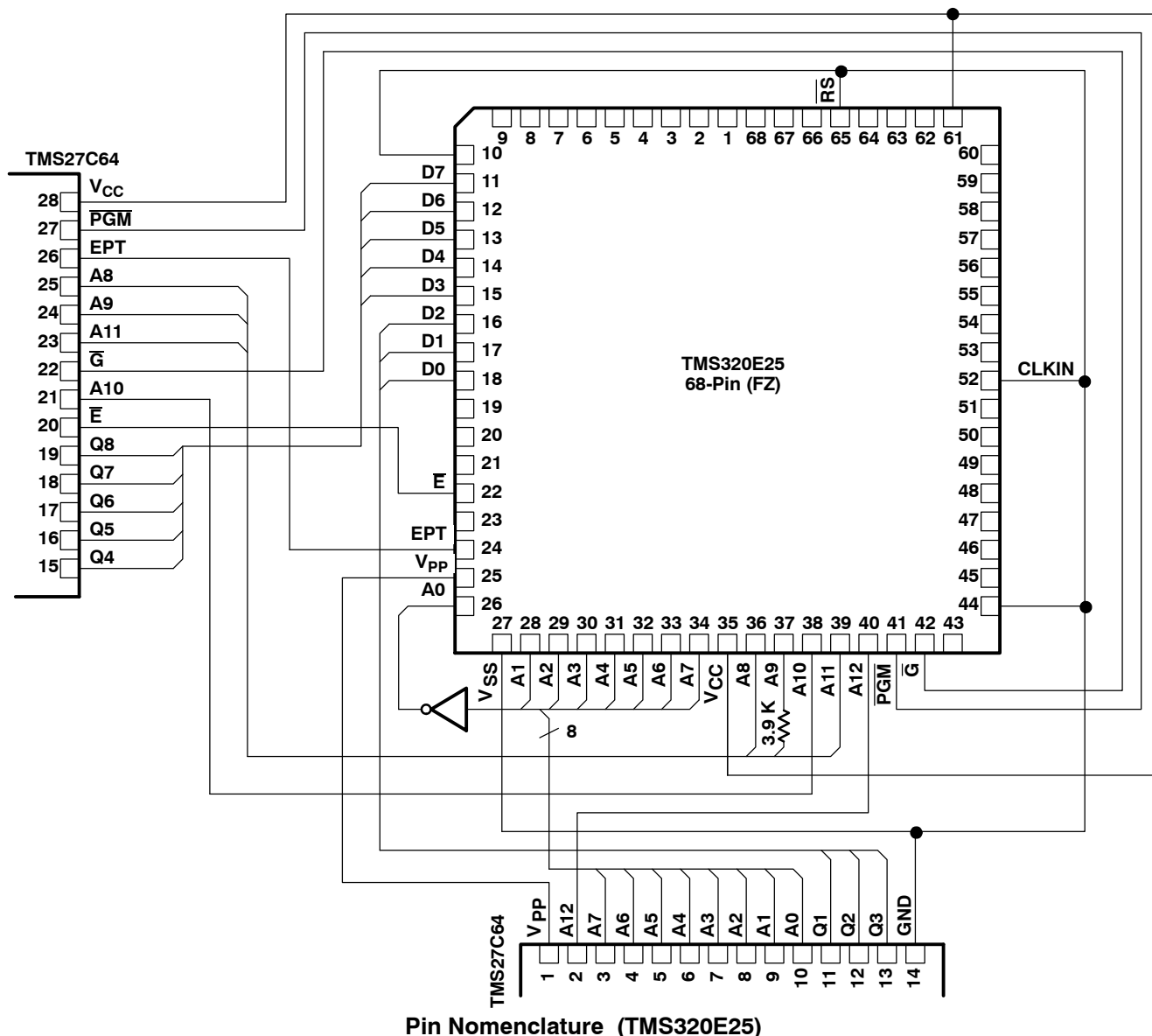

Pin Nomenclature (TMS320E25)

SIGNALS	I/O	DEFINITION
A12 (MSB)-A0 (LSB)	I	On-chip EPROM programming address lines
CLIN	I	Clock oscillator input
E	I	EPROM chip select
EPT	I	EPROM test mode select
G	I	EPROM read/verify select
GND	I	Ground
PGM	I	EPROM write/program select
Q8 (MSB)-Q1 (LSB)	I/O	Data lines for byte-wide programming of on-chip 8K bytes of EPROM
RS	I	Reset for initializing the device
VCC	I	5-V power supply
VPP	I	12.5-V power supply

Figure 9. TMS320E25 EPROM Conversion to TMS27C64 EPROM Pinout

ADVANCE INFORMATION

Table 5 shows the programming levels required for programming, verifying and reading the EPROM cell. The paragraphs following the table describe the function of each programming level.

**Table 5. TMS320E25 Programming Mode Levels**

SIGNAL NAME†	TMS320E25 PIN	TMS27C64 PIN	PROGRAM	PROGRAM VERIFY	PROGRAM INHIBIT	READ	OUTPUT DISABLE
$\overline{E}$	22	20	$V_{IL}$	$V_{IL}$	$V_{IH}$	$V_{IL}$	$V_{IL}$
$\overline{G}$	42	22	$V_{IH}$	PULSE	X	PULSE	$V_{IH}$
$\overline{PGM}$	41	27	PULSE	$V_{IH}$	X	$V_{IH}$	$V_{IH}$
$V_{PP}$	25	1	$V_{PP}$	$V_{PP}$	$V_{PP}$	$V_{CC}$	$V_{CC}$
$V_{CC}$	61,35	28	$V_{CC+1}$	$V_{CC+1}$	$V_{CC+1}$	$V_{CC}$	$V_{CC}$
$V_{SS}$	27,44,10	14	$V_{SS}$	$V_{SS}$	$V_{SS}$	$V_{SS}$	$V_{SS}$
CLKIN	52	14	$V_{SS}$	$V_{SS}$	$V_{SS}$	$V_{SS}$	$V_{SS}$
$\overline{RS}$	65	14	$V_{SS}$	$V_{SS}$	$V_{SS}$	$V_{SS}$	$V_{SS}$
EPT	24	26	$V_{SS}$	$V_{SS}$	$V_{SS}$	$V_{SS}$	$V_{SS}$
Q1-Q8	18-11	11-13,15-19	$D_{IN}$	$Q_{OUT}$	HI-Z	$Q_{OUT}$	HI-Z
A12-A10	40-38	2,23,21,	ADDR	ADDR	X	ADDR	X
A9-A7	37,36,34	24,25,3	ADDR	ADDR	X	ADDR	X
A6	33	4	ADDR	ADDR	X	ADDR	X
A5	32	5	ADDR	ADDR	X	ADDR	X
A4	31	3	ADDR	ADDR	X	ADDR	X
A3-A0	30-28,26	7-10	ADDR	ADDR	X	ADDR	X

† In accordance with TMS27C64.

**LEGEND;**

$V_{IH}$  = TTL high level;  $V_{IL}$  = TTL low level; ADDR = byte address bit

$V_{PP}$  =  $12.5\text{ V} \pm 0.5\text{ V}$ ;  $V_{CC}$  =  $5 \pm 0.25\text{ V}$ ; X = don't care

PULSE = low-going TTL level pulse;  $D_{IN}$  = byte to be programmed at ADDR

$Q_{OUT}$  = byte stored at ADDR; RBIT = ROM protect bit.

**erasure**

Before programming, the device is erased by exposing the chip through the transparent lid to high-intensity ultraviolet light (wavelength 2537 Å). The recommended minimum exposure dose (UV-intensity × exposure-time) is  $15\text{ W}\cdot\text{s}/\text{cm}^2$ . A typical  $12\text{ mW}/\text{cm}^2$ , filterless UV lamp will erase the device in 21 minutes. The lamp should be located approximately 2.5 cm above the chip during erasure. After erasure, all bits are in the high state. Note that normal ambient light contains the correct wavelength for erasure. Therefore, when using the TMS320E25, the window should be covered with an opaque label.

**fast programming**

After erasure (all memory bits in the cell are logic one), logic zeroes are programmed into the desired locations. The fast programming algorithm, shown in Figure 10, is normally used to program the entire EPROM contents, although individual locations may be programmed separately. A programmed logic zero can be erased only by ultraviolet light. Data is presented in parallel (eight bits) on pins Q8-Q1. Once addresses and data are stable,  $\overline{PGM}$  is pulsed. The programming mode is achieved when  $V_{PP} = 12.5\text{ V}$ ,  $\overline{PGM} = V_{IL}$ ,  $V_{CC} = 6\text{ V}$ ,  $\overline{G} = V_{IH}$ , and  $\overline{E} = V_{IL}$ . More than one TMS320E25 can be programmed when the devices are connected in parallel. Locations can be programmed in any order.

Programming uses two types of programming pulses: prime and final. The length of the prime pulse is 1 ms. After each prime pulse, the byte being programmed is verified. If correct data is read, the final programming pulse is applied; if correct data is not read, an additional 1-ms prime pulse is applied up to a maximum of 15 times. The final programming pulse is 4 ms times the number of prime programming pulses applied. This sequence of programming and verification is performed at  $V_{CC} = 6\text{ V}$ , and  $V_{PP} = 12.5\text{ V}$ . When the full fast programming routine is complete, all bits are verified with  $V_{CC} = V_{PP} = 5\text{ V}$ .

**program verify**

Programmed bits may be verified with  $V_{PP} = 12.5\text{ V}$  when  $\overline{G} = V_{IL}$ ,  $\overline{E} = V_{IL}$ , and  $\overline{PGM} = V_{IH}$ . Figure 11 shows the timing for the program and verify operation.

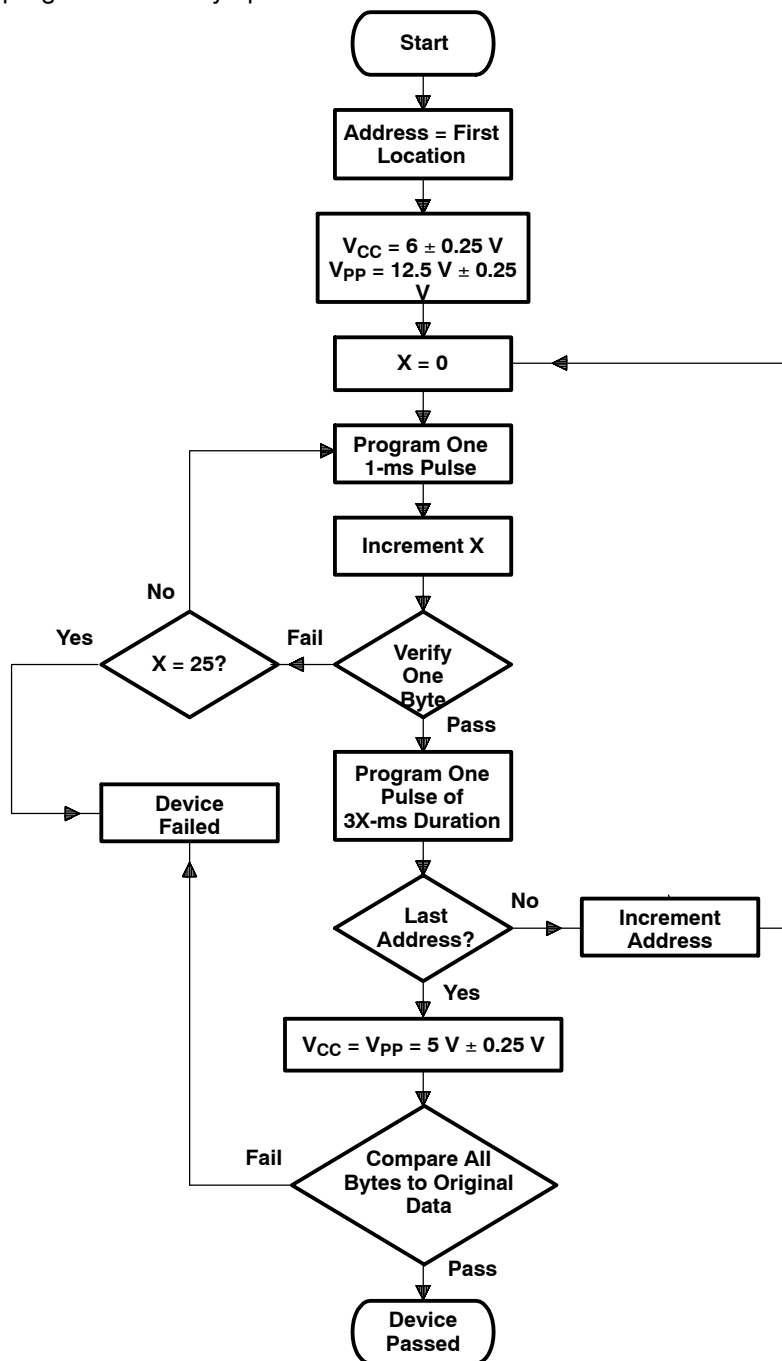

Figure 10. Fast Programming Flowchart

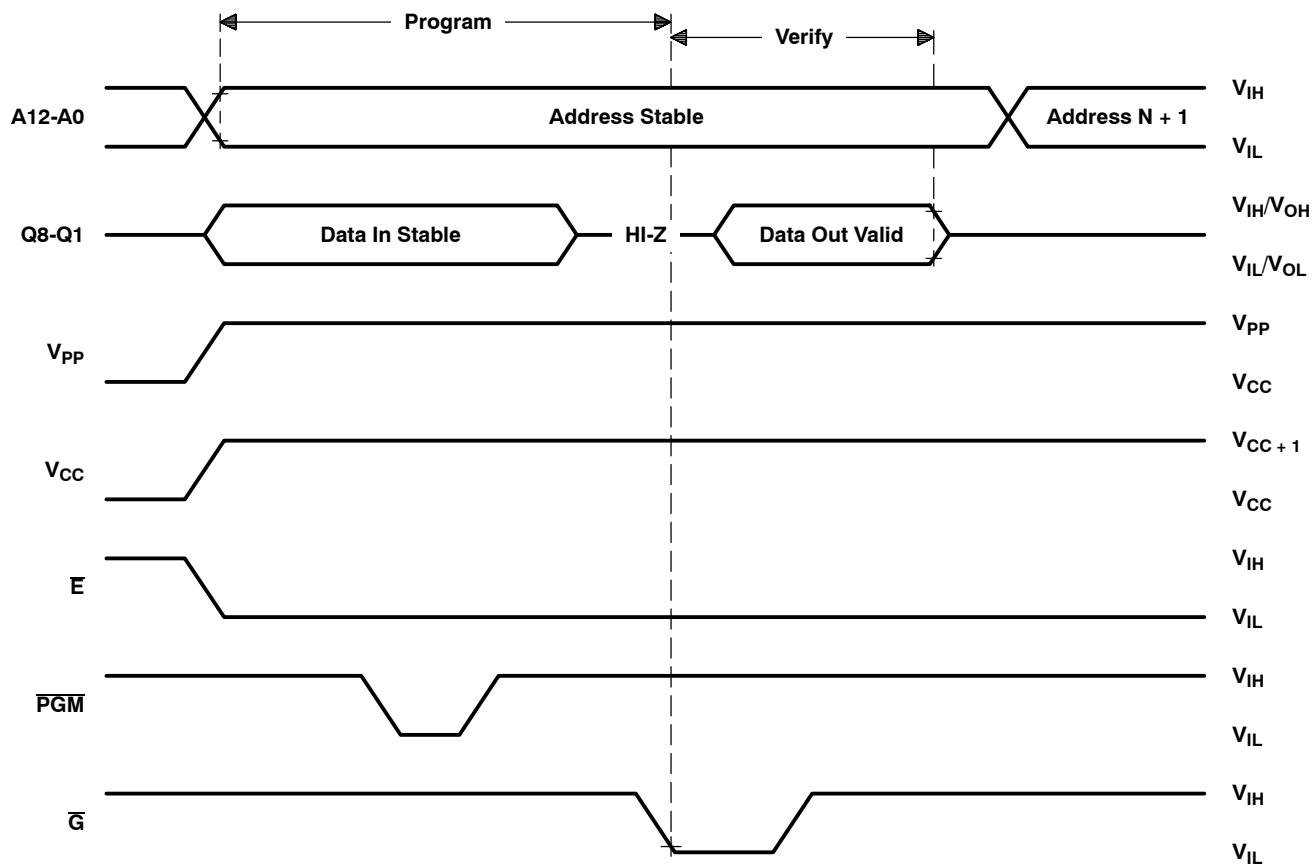

Figure 11. Fast Programming Timing

**program inhibit**

Programming may be inhibited by maintaining a high level input on the  $\bar{E}$  pin or  $\overline{PGM}$  pin.

**read**

The EPROM contents may be read independent of the programming cycle, provided the RBIT (ROM protect bit) has not been programmed. The read is accomplished by setting  $\bar{E}$  to zero and pulsing  $\overline{G}$  low. The contents of the EPROM location selected by the value on the address inputs appear on Q8-Q1.

**output disable**

During the EPROM programming process, the EPROM data outputs may be disabled, if desired, by establishing the output disable state. This state is selected by setting the  $\overline{G}$  and  $\overline{PGM}$  pins high. While output disable is selected, Q8-Q1 are placed in the high-impedance state.

**ROM protection and verification**

This section describes the code protection feature included in the EPROM cell, which protects code against copyright violations. Table 6 shows the programming levels required for protecting and verifying the EPROM. The paragraphs following the table describe the protect and verify functions.

Table 6. TMS320E25 Protect and Verify EPROM Mode Levels

SIGNAL <sup>†</sup>	TMS320E25 PIN	TMS27C64 PIN	ROM PROTECT	PROTECT VERIFY
$\bar{E}$	22	20	$V_{IH}$	$V_{IL}$
$\bar{G}$	42	22	$V_{IH}$	$V_{IL}$
PGM	41	27	$V_{IH}$	$V_{IH}$
$V_{PP}$	25	1	$V_{PP}$	$V_{CC}$
$V_{CC}$	61,35	28	$V_{CC+1}$	$V_{CC}$
$V_{SS}$	10, 27, 44	14	$V_{SS}$	$V_{SS}$
CLKIN	52	14	$V_{SS}$	$V_{SS}$
$\bar{RS}$	65	14	$V_{SS}$	$V_{SS}$
EPT	24	26	$V_{PP}$	$V_{PP}$
Q8-Q1	18-11	11-13, 15-19	Q8 = PULSE	Q8 = RBIT
A12-A10	40-38	2, 23, 21,	X	X
A9-A7	37, 36, 34	24, 25, 3	X	X
A6	33	4	X	$V_{IL}$
A5	32	5	X	X
A4	31	6	$V_{IH}$	X
A3-A0	30-28, 26	7-10	X	X

<sup>†</sup> In accordance with TMS27C64.

**LEGEND;**

$V_{IH}$  = TTL high level;  $V_{IL}$  = TTL low level;  $V_{CC} = 5\text{ V} \pm 0.25\text{ V}$

$V_{PP} = 12.5\text{ V} \pm 0.5\text{ V}$ ; X = don't care

PULSE = low-going TTL level pulse; RBIT = ROM protect bit.

**EPROM protect**

The EPROM protect facility is used to completely disable reading of the EPROM contents to guarantee security of proprietary algorithms. This facility is implemented through a unique EPROM cell called the RBIT (EPROM protect bit) cell. Once the contents to be protected are programmed into the EPROM, the RBIT is programmed, disabling access to the EPROM contents and disabling the microprocessor mode on the device. Once programmed, the RBIT can be cleared only by erasing the entire EPROM array with ultraviolet light, thereby maintaining security of the proprietary algorithm. Programming the RBIT is accomplished using the EPROM protect cycle, which consists of setting the  $\bar{E}$ ,  $\bar{G}$ , PGM, and A4 pins high,  $V_{PP}$  and EPT to  $2.5\text{ V} \pm 0.5\text{ V}$ , and pulsing Q8 low. The complete sequence of operations involved in programming the RBIT is shown in the flowchart of Figure 12. The required setups in the figure are detailed in Table 6.

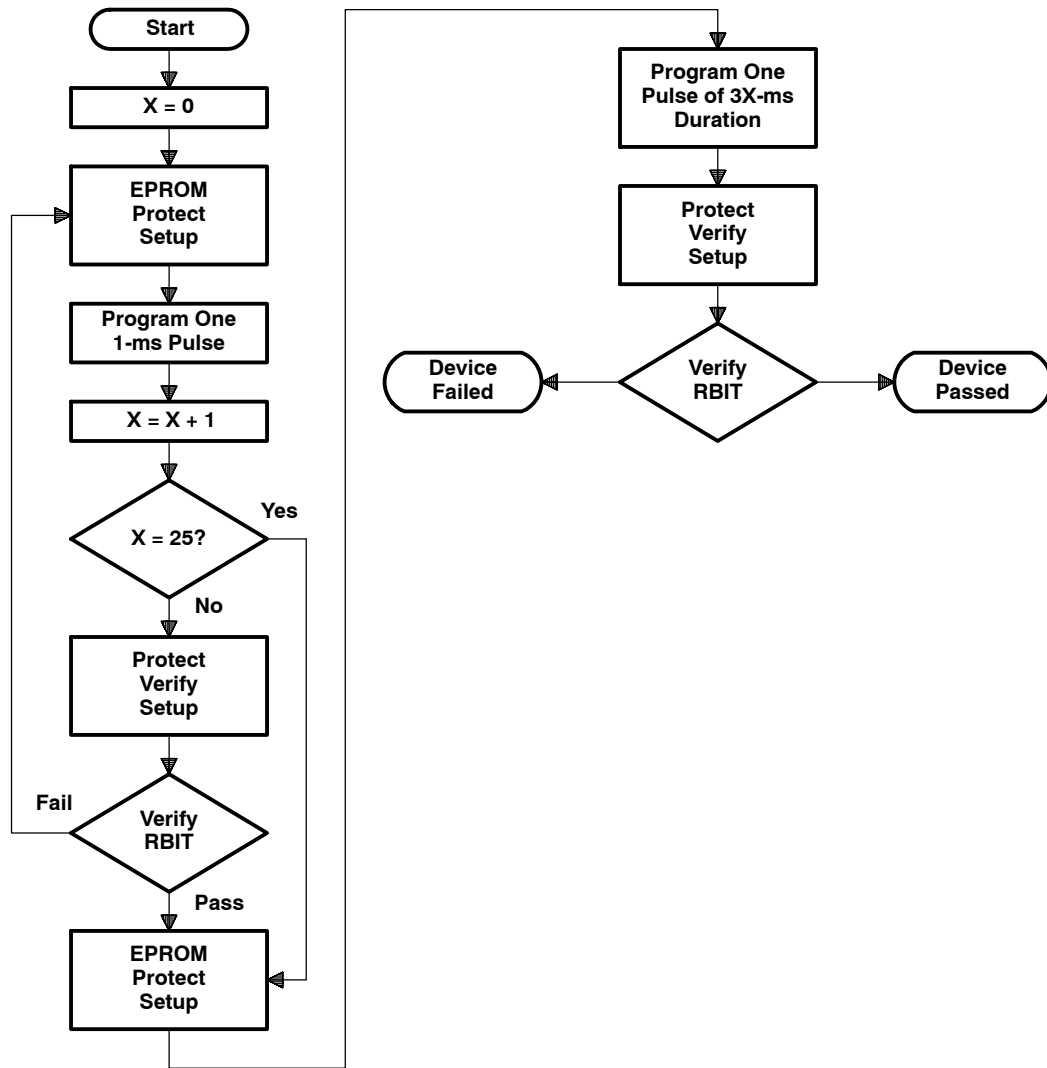

Figure 12. EPROM Protect Flowchart

protect verify

Protect verify is used following the EPROM protect to verify correct programming of the RBIT (see Figure 12). When using protect verify, Q8 outputs the state of the RBIT. When RBIT = 1, the EPROM is unprotected; when RBIT = 0, the EPROM is protected. The EPROM protect and verify timings are shown in Figure 13.



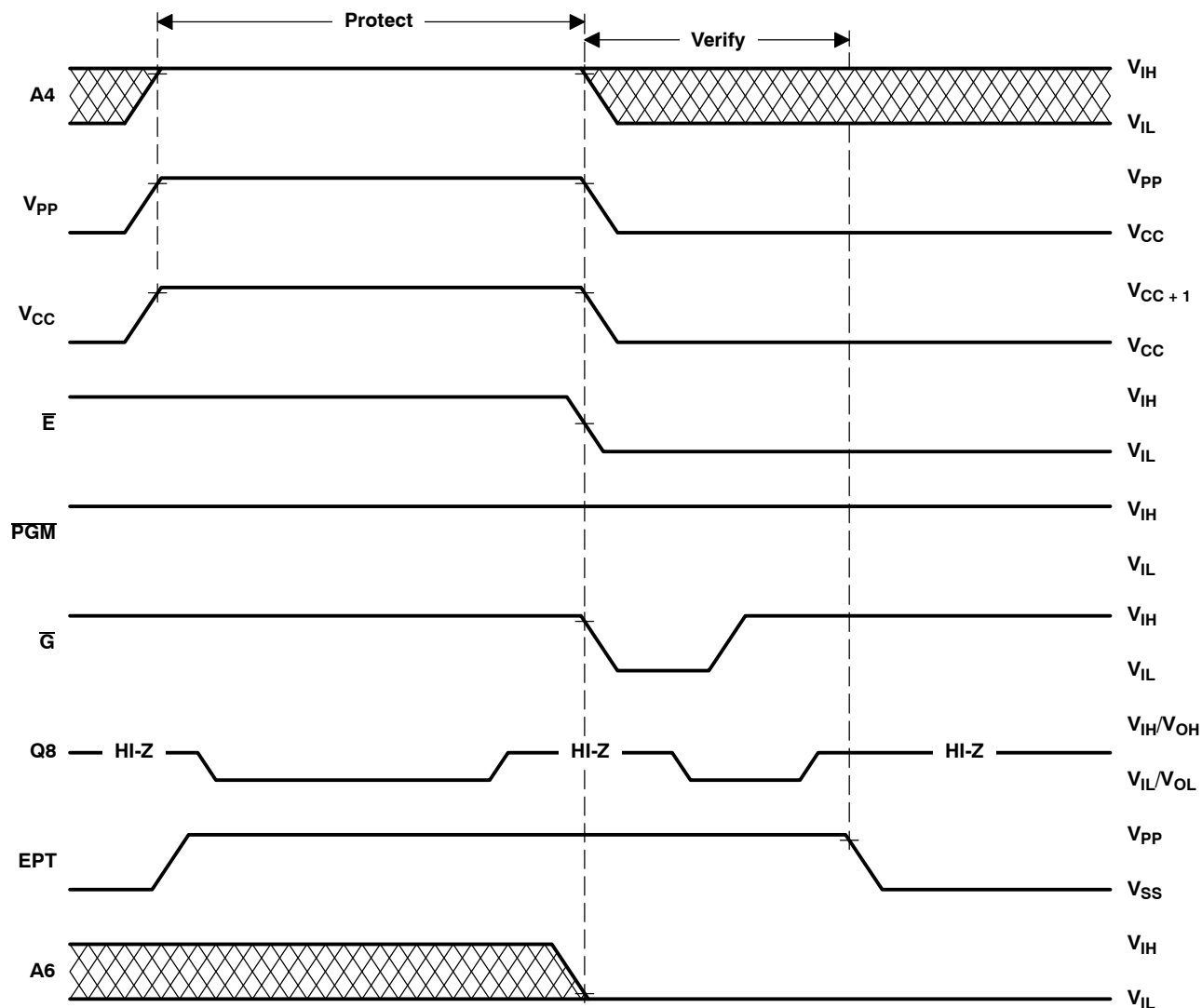

Figure 13. EPROM Protect Timing

ADVANCE INFORMATION

**ADVANCE INFORMATION**

accumulator .....	5	microcomputer/microprocessor mode	
adapter socket .....	58	multiplier .....	7
addressing modes .....	10	multiprocessing .....	9
ALU .....	5	operation conditions	
architecture .....	5	TMS32020 .....	17, 21
BIT instruction .....	17	TMS320C25 .....	27
block diagram .....	6	TMS320C25-50 .....	34
Bulletin board Service .....	18	TMS320E25 .....	27, 33
clock		overflow .....	17
TMS32020 .....	22	overview	
TMS320C25/E25 .....	28, 29	TMS320 .....	5
TMS320C25-50 .....	35, 36	specification .....	20
description .....	1	package types .....	1-5
development support .....	18, 19	pin assignments .....	2
direct addressing .....	10, 17	pin nomenclature	
DMA documentation support .....	20	TMS32020/C25/C25-50 .....	2
EPROM protection/verification .....	58-65	TMS320E25 .....	60
external interface .....	9	pinouts	
flowcharts		TMS32020/C25/C25-50 .....	1
EPROM protect .....	63	TMS320E25 .....	60
fast .....	60, 61	programming levels for EPROM .....	58-65
hotline .....	18	repeat feature .....	10
immediate addressing .....	10	reflow soldering precaution .....	54
indirect addressing .....	10, 17	serial port .....	7, 9
instruction set .....	10-16	shifter .....	7
interrupts .....	9	specification overview .....	20
introduction .....	3	subroutines .....	9
key features		supply current characteristics .....	54
TMS320 family .....	1	switching characteristics	
TMS32020 .....	4	TMS32020 .....	21, 23-26
TMS320C25/C25-50/E25 .....	4	TMS320C25/E25 .....	27, 28-33
mechanical data		TMS320C25-50 .....	34, 35-40
TMS32020 .....	55	timer .....	7
TMS320C25 .....	55, 56	timing diagrams .....	41-53, 62, 65
TMS320C25-50 .....	56	TMS320 Second-Generation .....	41-47
TMS320E25 .....	57	TMS32020 .....	46, 48, 50, 51
memory		TMS320C25/E25 .....	46, 49, 52, 53
addressing modes .....	10, 17	TMS3220 product notification .....	17
control .....	7		
maps .....	8		

**PACKAGING INFORMATION**

Orderable part number	Status (1)	Material type (2)	Package   Pins	Package qty   Carrier	RoHS (3)	Lead finish/ Ball material (4)	MSL rating/ Peak reflow (5)	Op temp (°C)	Part marking (6)
<a href="#">TMS320C25FNA</a>	NRND	Production	PLCC (FN)   68	18   TUBE	Yes	NIPDAU	Level-3-260C-168 HR	-40 to 85	@1986 TI TMS320C25FNA
TMS320C25FNA.A	NRND	Production	PLCC (FN)   68	18   TUBE	Yes	NIPDAU	Level-3-260C-168 HR	-40 to 85	@1986 TI TMS320C25FNA
TMS320C25FNL	NRND	Production	PLCC (FN)   68	18   TUBE	Yes	NIPDAU	Level-3-260C-168 HR	0 to 70	@1990 TI TMS320C25FNL
TMS320C25FNL.A	NRND	Production	PLCC (FN)   68	18   TUBE	Yes	NIPDAU	Level-3-260C-168 HR	0 to 70	@1990 TI TMS320C25FNL
TMS320C25FNLR	NRND	Production	PLCC (FN)   68	250   LARGE T&R	Yes	NIPDAU	Level-3-260C-168 HR	0 to 70	@1990 TI TMS320C25FNL
TMS320C25FNLR.A	NRND	Production	PLCC (FN)   68	250   LARGE T&R	Yes	NIPDAU	Level-3-260C-168 HR	0 to 70	@1990 TI TMS320C25FNL
<a href="#">TMS320C25GBA</a>	NRND	Production	CPGA (GB)   68	21   JEDEC TRAY (10+1)	ROHS Exempt	AU	N/A for Pkg Type	-40 to 85	@1986 TI TMS320C25GBA
TMS320C25GBA.A	NRND	Production	CPGA (GB)   68	21   JEDEC TRAY (10+1)	ROHS Exempt	AU	N/A for Pkg Type	-40 to 85	@1986 TI TMS320C25GBA
TMS320C25GBL	NRND	Production	CPGA (GB)   68	21   JEDEC TRAY (5+1)	ROHS Exempt	AU	N/A for Pkg Type	0 to 70	@1990 TI TMS320C25GBL
TMS320C25GBL.A	NRND	Production	CPGA (GB)   68	21   JEDEC TRAY (5+1)	ROHS Exempt	AU	N/A for Pkg Type	0 to 70	@1990 TI TMS320C25GBL

(1) **Status:** For more details on status, see our [product life cycle](#).

(2) **Material type:** When designated, preproduction parts are prototypes/experimental devices, and are not yet approved or released for full production. Testing and final process, including without limitation quality assurance, reliability performance testing, and/or process qualification, may not yet be complete, and this item is subject to further changes or possible discontinuation. If available for ordering, purchases will be subject to an additional waiver at checkout, and are intended for early internal evaluation purposes only. These items are sold without warranties of any kind.

(3) **RoHS values:** Yes, No, RoHS Exempt. See the [TI RoHS Statement](#) for additional information and value definition.

(4) **Lead finish/Ball material:** Parts may have multiple material finish options. Finish options are separated by a vertical ruled line. Lead finish/Ball material values may wrap to two lines if the finish value exceeds the maximum column width.

(5) **MSL rating/Peak reflow:** The moisture sensitivity level ratings and peak solder (reflow) temperatures. In the event that a part has multiple moisture sensitivity ratings, only the lowest level per JEDEC standards is shown. Refer to the shipping label for the actual reflow temperature that will be used to mount the part to the printed circuit board.

(6) **Part marking:** There may be an additional marking, which relates to the logo, the lot trace code information, or the environmental category of the part.

Multiple part markings will be inside parentheses. Only one part marking contained in parentheses and separated by a "~" will appear on a part. If a line is indented then it is a continuation of the previous line and the two combined represent the entire part marking for that device.

**Important Information and Disclaimer:**The information provided on this page represents TI's knowledge and belief as of the date that it is provided. TI bases its knowledge and belief on information provided by third parties, and makes no representation or warranty as to the accuracy of such information. Efforts are underway to better integrate information from third parties. TI has taken and continues to take reasonable steps to provide representative and accurate information but may not have conducted destructive testing or chemical analysis on incoming materials and chemicals. TI and TI suppliers consider certain information to be proprietary, and thus CAS numbers and other limited information may not be available for release.

In no event shall TI's liability arising out of such information exceed the total purchase price of the TI part(s) at issue in this document sold by TI to Customer on an annual basis.

**OTHER QUALIFIED VERSIONS OF TMS320C25 :**

- Military : [SMJ320C25](#)

NOTE: Qualified Version Definitions:

- Military - QML certified for Military and Defense Applications

**TUBE**

\*All dimensions are nominal

Device	Package Name	Package Type	Pins	SPQ	L (mm)	W (mm)	T (μm)	B (mm)
TMS320C25FNA	FN	PLCC	68	18	506.98	25.91	5330	5.33
TMS320C25FNA.A	FN	PLCC	68	18	506.98	25.91	5330	5.33
TMS320C25FNL	FN	PLCC	68	18	506.98	25.91	5330	5.33
TMS320C25FNL.A	FN	PLCC	68	18	506.98	25.91	5330	5.33

## IMPORTANT NOTICE AND DISCLAIMER

TI PROVIDES TECHNICAL AND RELIABILITY DATA (INCLUDING DATASHEETS), DESIGN RESOURCES (INCLUDING REFERENCE DESIGNS), APPLICATION OR OTHER DESIGN ADVICE, WEB TOOLS, SAFETY INFORMATION, AND OTHER RESOURCES "AS IS" AND WITH ALL FAULTS, AND DISCLAIMS ALL WARRANTIES, EXPRESS AND IMPLIED, INCLUDING WITHOUT LIMITATION ANY IMPLIED WARRANTIES OF MERCHANTABILITY, FITNESS FOR A PARTICULAR PURPOSE OR NON-INFRINGEMENT OF THIRD PARTY INTELLECTUAL PROPERTY RIGHTS.

These resources are intended for skilled developers designing with TI products. You are solely responsible for (1) selecting the appropriate TI products for your application, (2) designing, validating and testing your application, and (3) ensuring your application meets applicable standards, and any other safety, security, regulatory or other requirements.

These resources are subject to change without notice. TI grants you permission to use these resources only for development of an application that uses the TI products described in the resource. Other reproduction and display of these resources is prohibited. No license is granted to any other TI intellectual property right or to any third party intellectual property right. TI disclaims responsibility for, and you fully indemnify TI and its representatives against any claims, damages, costs, losses, and liabilities arising out of your use of these resources.

TI's products are provided subject to [TI's Terms of Sale](#), [TI's General Quality Guidelines](#), or other applicable terms available either on [ti.com](http://ti.com) or provided in conjunction with such TI products. TI's provision of these resources does not expand or otherwise alter TI's applicable warranties or warranty disclaimers for TI products. Unless TI explicitly designates a product as custom or customer-specified, TI products are standard, catalog, general purpose devices.

TI objects to and rejects any additional or different terms you may propose.

Copyright © 2026, Texas Instruments Incorporated

Last updated 10/2025