

# TMUX111x 5V, Low-Leakage-Current, 1:1 (SPST), 4-Channel Precision Switches

## 1 Features

- Wide supply range: 1.08V to 5.5V
- Low leakage current: 3pA
- Low charge injection: -1.5pC
- Low on-resistance: 2Ω
- -40°C to +125°C operating temperature
- [1.8V Logic compatible](#)
- [Fail-safe logic](#)
- [Rail to rail operation](#)
- [Bidirectional signal path](#)
- Break-before-make switching
- ESD protection HBM: 2000V

## 2 Applications

- Sample-and-hold circuits
- Feedback gain switching
- Signal isolation
- Field transmitters
- Programmable logic controllers (PLC)
- [Factory automation and control](#)
- [Ultrasound scanners](#)
- [Patient monitoring and diagnostics](#)
- [Electrocardiogram \(ECG\)](#)
- [Data acquisition systems \(DAQ\)](#)
- ATE test equipment
- Battery test equipment
- Instrumentation: lab, analytical, portable
- Smart meters: [water](#) and [gas](#)
- [Optical networking](#)
- [Optical test equipment](#)

## 3 Description

The TMUX1111, TMUX1112, and TMUX1113 are precision complementary metal-oxide semiconductor (CMOS) devices that have four independently selectable 1:1, single-pole, single-throw (SPST) switches. Wide operating supply of 1.08V to 5.5V allows for use in a broad array of applications from medical equipment to industrial systems. The device supports bidirectional analog and digital signals on the source (Sx) and drain (Dx) pins ranging from GND to V<sub>DD</sub>.

The switches of the TMUX1111 are turned on with Logic 0 on the appropriate logic control inputs, while Logic 1 is required to turn on switches in the TMUX1112. The four channels of the TMUX1113 are split with two switches supporting Logic 0, while the other two switches support Logic 1. The TMUX1113 exhibits break-before-make switching, allowing the device to be used in cross-point switching applications.

The TMUX111x devices are part of the precision switches and multiplexers family. These devices have very low on and off leakage currents and low charge injection, allowing them to be used in high precision measurement applications. A low supply current of 8 nA and small package options enable use in portable applications.

### Device Information

PART NUMBER <sup>(1)</sup>	CONTROL LOGIC <sup>(1)</sup>	PACKAGE <sup>(2)</sup>
TMUX1111	Active Low	PW (TSSOP, 16) RSV (UQFN, 16)
TMUX1112	Active High	
TMUX1113	Mixed	

(1) See [Device Comparison](#).

(2) For more information, see [Section 12](#).

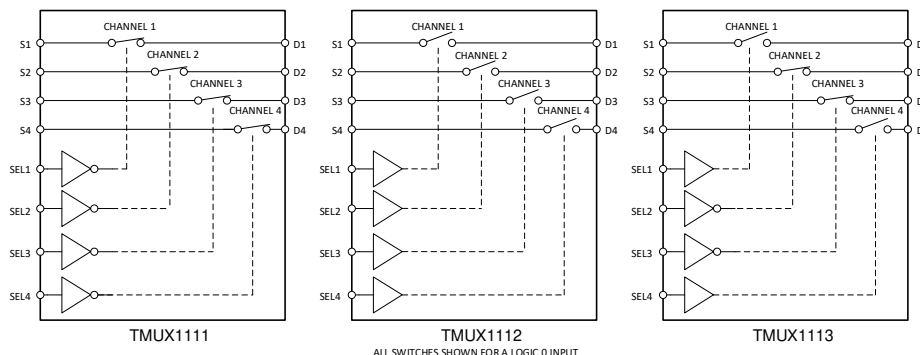

**TMUX111x Block Diagrams**



## Table of Contents

<b>1 Features</b> .....	1	7.9 Bandwidth.....	21
<b>2 Applications</b> .....	1	<b>8 Detailed Description</b> .....	22
<b>3 Description</b> .....	1	8.1 Overview.....	22
<b>4 Device Comparison Table</b> .....	2	8.2 Functional Block Diagram.....	22
<b>5 Pin Configuration and Functions</b> .....	3	8.3 Feature Description.....	22
<b>6 Specifications</b> .....	4	8.4 Device Functional Modes.....	24
6.1 Absolute Maximum Ratings.....	4	8.5 Truth Tables.....	24
6.2 ESD Ratings.....	4	<b>9 Application and Implementation</b> .....	25
6.3 Recommended Operating Conditions.....	4	9.1 Application Information.....	25
6.4 Thermal Information.....	5	9.2 Typical Application - Sample-and-Hold Circuit.....	25
6.5 Electrical Characteristics (V <sub>DD</sub> = 5V ±10 %).....	6	9.3 Typical Application - Switched Gain Amplifier.....	27
6.6 Electrical Characteristics (V <sub>DD</sub> = 3.3V ±10 %).....	8	9.4 Power Supply Recommendations.....	29
6.7 Electrical Characteristics (V <sub>DD</sub> = 1.8V ±10 %).....	10	9.5 Layout.....	29
6.8 Electrical Characteristics (V <sub>DD</sub> = 1.2V ±10 %).....	12	<b>10 Device and Documentation Support</b> .....	31
6.9 Typical Characteristics.....	14	10.1 Documentation Support.....	31
<b>7 Parameter Measurement Information</b> .....	17	10.2 Receiving Notification of Documentation Updates.....	31
7.1 On-resistance.....	17	10.3 Support Resources.....	31
7.2 Off-leakage current.....	17	10.4 Trademarks.....	31
7.3 On-leakage current.....	18	10.5 Electrostatic Discharge Caution.....	31
7.4 Transition time.....	18	10.6 Glossary.....	31
7.5 Break-before-make.....	19	<b>11 Revision History</b> .....	31
7.6 Charge injection.....	19	<b>12 Mechanical, Packaging, and Orderable Information</b> .....	32
7.7 Off isolation.....	20		
7.8 Channel-to-Channel Crosstalk.....	20		

## 4 Device Comparison Table

PRODUCT	DESCRIPTION
TMUX1111	Low-Leakage-Current, Precision, 4-Channel, 1:1 (SPST) Switches (Normally Closed)
TMUX1112	Low-Leakage-Current, Precision, 4-Channel, 1:1 (SPST) Switches (Normally Open)
TMUX1113	Low-Leakage-Current, Precision, 4-Channel, 1:1 (SPST) Switches (Dual Open + Dual Closed)

## 5 Pin Configuration and Functions

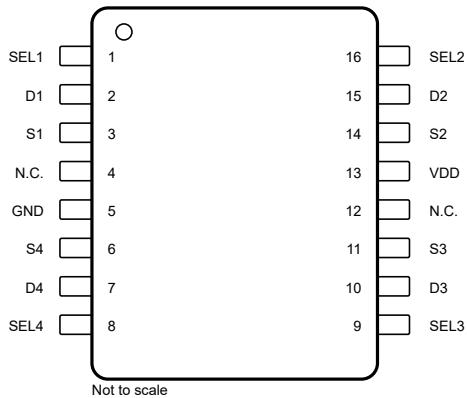

**Figure 5-1. PW Package, 16-Pin TSSOP (Top View)**

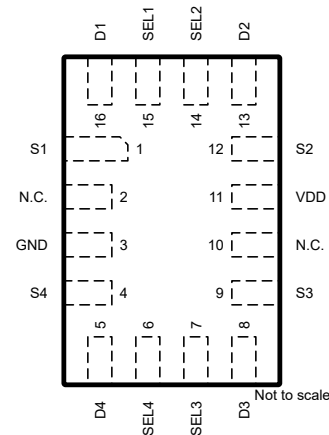

**Figure 5-2. RSV Package, 16-Pin UQFN (Top View)**

**Table 5-1. Pin Functions**

PIN			TYPE <sup>(1)</sup>	DESCRIPTION
NAME	TSSOP	UQFN		
SEL1	1	15	I	Logic control input 1. Controls channel 1 state as shown in <a href="#">Section 8.5</a> .
D1	2	16	I/O	Drain pin 1. Can be an input or output.
S1	3	1	I/O	Source pin 1. Can be an input or output.
N.C.	4	2	—	No internal connection.
GND	5	3	P	Ground (0 V) reference
S4	6	4	I/O	Source pin 4. Can be an input or output.
D4	7	5	I/O	Drain pin 4. Can be an input or output.
SEL4	8	6	I	Logic control input 4. Controls channel 4 state as shown in <a href="#">Section 8.5</a> .
SEL3	9	7	I	Logic control input 3. Controls channel 3 state as shown in <a href="#">Section 8.5</a> .
D3	10	8	I/O	Drain pin 3. Can be an input or output.
S3	11	9	I/O	Source pin 3. Can be an input or output.
N.C.	12	10	—	No internal connection.
VDD	13	11	P	Positive power supply. This pin is the most positive power-supply potential. For reliable operation, connect a decoupling capacitor ranging from 0.1 $\mu$ F to 10 $\mu$ F between $V_{DD}$ and GND.
S2	14	12	I/O	Source pin 2. Can be an input or output.
D2	15	13	I/O	Drain pin 2. Can be an input or output.
SEL2	16	14	I	Logic control input 2. Controls channel 2 state as shown in <a href="#">Section 8.5</a> .

(1) I = input, O = output, I/O = input and output, P = power

## 6 Specifications

### 6.1 Absolute Maximum Ratings

over operating free-air temperature range (unless otherwise noted) <sup>(1)</sup> <sup>(2)</sup> <sup>(3)</sup>

		MIN	MAX	UNIT
V <sub>DD</sub>	Supply voltage	-0.5	6	V
V <sub>SEL</sub>	Logic control input pin voltage (SELx)	-0.5	6	V
I <sub>SEL</sub>	Logic control input pin current (SELx)	-30	30	mA
V <sub>S</sub> or V <sub>D</sub>	Source or drain voltage (Sx, Dx)	-0.5	V <sub>DD</sub> +0.5	V
I <sub>S</sub> or I <sub>D (CONT)</sub>	Source or drain continuous current (Sx, Dx)	I <sub>DC</sub> ± 10 % <sup>(4)</sup>	I <sub>DC</sub> ± 10 % <sup>(4)</sup>	mA
I <sub>S</sub> or I <sub>D (PEAK)</sub>	Source and drain peak current: (1 ms period max, 10% duty cycle maximum) (Sx, D)	I <sub>peak</sub> ± 10 % <sup>(4)</sup>	I <sub>peak</sub> ± 10 % <sup>(4)</sup>	mA
T <sub>stg</sub>	Storage temperature	-65	150	°C
P <sub>tot</sub>	Total power dissipation <sup>(5)</sup> <sup>(6)</sup>		500	mW
T <sub>J</sub>	Junction temperature		150	°C

- (1) Stresses beyond those listed under *Absolute Maximum Rating* may cause permanent damage to the device. These are stress ratings only, which do not imply functional operation of the device at these or any other conditions beyond those indicated under *Recommended Operating Condition*. Exposure to absolute-maximum-rated conditions for extended periods may affect device reliability.
- (2) The algebraic convention, whereby the most negative value is a minimum and the most positive value is a maximum.
- (3) All voltages are with respect to ground, unless otherwise specified.
- (4) Refer to Recommended Operating Conditions for I<sub>DC</sub> and I<sub>Peak</sub> ratings.
- (5) For PW package: P<sub>tot</sub> derates linearly above TA=88°C by 8.08mW/°C
- (6) For QFN package: P<sub>tot</sub> derates linearly above TA=76°C by 6.81mW/°C

### 6.2 ESD Ratings

			VALUE	UNIT
V <sub>(ESD)</sub>	Electrostatic discharge	Human body model (HBM), per ANSI/ESDA/JEDEC JS-001, all pins <sup>(1)</sup>	±2000	V
		Charged device model (CDM), per JEDEC specification JESD22-C101 or ANSI/ESDA/JEDEC JS-002, all pins <sup>(2)</sup>	±750	

- (1) JEDEC document JEP155 states that 500V HBM allows safe manufacturing with a standard ESD control process.
- (2) JEDEC document JEP157 states that 250V CDM allows safe manufacturing with a standard ESD control process.

### 6.3 Recommended Operating Conditions

over operating free-air temperature range (unless otherwise noted)

			MIN	NOM	MAX	UNIT
V <sub>DD</sub>	Positive power supply voltage		1.08		5.5	V
V <sub>S</sub> or V <sub>D</sub>	Signal path input/output voltage (source or drain pin) (Sx, Dx)		0		V <sub>DD</sub>	V
V <sub>SEL</sub>	Logic control input pin voltage (SELx)		0		5.5	V
T <sub>A</sub>	Ambient temperature		-40		125	°C
I <sub>DC</sub>	Continuous current through switch	T <sub>J</sub> = 25°C		150		mA
		T <sub>J</sub> = 85°C		120		mA
		T <sub>J</sub> = 125°C		60		mA
		T <sub>J</sub> = 130°C		50		mA
I <sub>peak</sub>	Peak current through switch(1 ms period max, 10% duty cycle maximum)	T <sub>J</sub> = 25°C		300		mA
		T <sub>J</sub> = 85°C		300		mA
		T <sub>J</sub> = 125°C		180		mA
		T <sub>J</sub> = 130°C		160		mA

## 6.4 Thermal Information

THERMAL METRIC <sup>(1)</sup>		TMUX1111 / TMUX1112 / TMUX1113		UNIT
		PW (TSSOP)	RSV (QFN)	
		16 PINS	16 PINS	
$R_{\theta JA}$	Junction-to-ambient thermal resistance	124.7	146.8	°C/W
$R_{\theta JC(top)}$	Junction-to-case (top) thermal resistance	54.8	83.5	°C/W
$R_{\theta JB}$	Junction-to-board thermal resistance	70.9	75.5	°C/W
$\Psi_{JT}$	Junction-to-top characterization parameter	10.8	9.0	°C/W
$\Psi_{JB}$	Junction-to-board characterization parameter	70.3	73.4	°C/W
$R_{\theta JC(bot)}$	Junction-to-case (bottom) thermal resistance	N/A	N/A	°C/W

(1) For more information about traditional and new thermal metrics, see the [Semiconductor and IC Package Thermal Metrics](#) application report.

## 6.5 Electrical Characteristics (V<sub>DD</sub> = 5V ±10 %)

at T<sub>A</sub> = 25°C, V<sub>DD</sub> = 5V (unless otherwise noted)

PARAMETER		TEST CONDITIONS	TA	MIN	TYP	MAX	UNIT
<b>ANALOG SWITCH</b>							
R <sub>ON</sub>	On-resistance	V <sub>S</sub> = 0V to V <sub>DD</sub> I <sub>SD</sub> = 10mA Refer to <a href="#">On-resistance</a>	25°C		2	4	Ω
			-40°C to +85°C			4.5	Ω
			-40°C to +125°C			4.9	Ω
ΔR <sub>ON</sub>	On-resistance matching between channels	V <sub>S</sub> = 0V to V <sub>DD</sub> I <sub>SD</sub> = 10mA Refer to <a href="#">On-resistance</a>	25°C		0.13		Ω
			-40°C to +85°C			0.4	Ω
			-40°C to +125°C			0.5	Ω
R <sub>ON</sub> FLAT	On-resistance flatness	V <sub>S</sub> = 0V to V <sub>DD</sub> I <sub>SD</sub> = 10mA Refer to <a href="#">On-resistance</a>	25°C		0.85		Ω
			-40°C to +85°C			1.6	Ω
			-40°C to +125°C			1.6	Ω
I <sub>S(OFF)</sub>	Source off leakage current <sup>(1)</sup>	V <sub>DD</sub> = 5V Switch Off V <sub>D</sub> = 4.5V / 1.5V V <sub>S</sub> = 1.5V / 4.5V Refer to <a href="#">Off-leakage current</a>	25°C	-0.08	±0.005	0.08	nA
			-40°C to +85°C			0.3	nA
			-40°C to +125°C			0.9	nA
I <sub>D(OFF)</sub>	Drain off leakage current <sup>(1)</sup>	V <sub>DD</sub> = 5V Switch Off V <sub>D</sub> = 4.5V / 1.5V V <sub>S</sub> = 1.5V / 4.5V Refer to <a href="#">Off-leakage current</a>	25°C	-0.08	±0.005	0.08	nA
			-40°C to +85°C			0.3	nA
			-40°C to +125°C			0.9	nA
I <sub>D(ON)</sub> I <sub>S(ON)</sub>	Channel on leakage current	V <sub>DD</sub> = 5V Switch On V <sub>D</sub> = V <sub>S</sub> = 2.5V Refer to <a href="#">On-leakage current</a>	25°C	-0.025	±0.003	0.025	nA
			-40°C to +85°C			0.2	nA
			-40°C to +125°C			0.95	nA
I <sub>D(ON)</sub> I <sub>S(ON)</sub>	Channel on leakage current	V <sub>DD</sub> = 5V Switch On V <sub>D</sub> = V <sub>S</sub> = 4.5V / 1.5V Refer to <a href="#">On-leakage current</a>	25°C	-0.1	±0.01	0.1	nA
			-40°C to +85°C			0.35	nA
			-40°C to +125°C			2	nA
<b>LOGIC INPUTS (SELx)</b>							
V <sub>IH</sub>	Input logic high		-40°C to +125°C	1.49		5.5	V
V <sub>IL</sub>	Input logic low		-40°C to +125°C	0		0.87	V
I <sub>IH</sub> I <sub>IL</sub>	Input leakage current		25°C		±0.005		μA
			-40°C to +125°C			±0.06	μA
C <sub>IN</sub>	Logic input capacitance		25°C		1		pF
C <sub>IN</sub>	Logic input capacitance		-40°C to +125°C			2	pF
<b>POWER SUPPLY</b>							
I <sub>DD</sub>	V <sub>DD</sub> supply current	Logic inputs = 0V or 5.5V	25°C		0.008		μA
			-40°C to +125°C			1	μA

## 6.5 Electrical Characteristics ( $V_{DD} = 5V \pm 10\%$ ) (continued)

at  $T_A = 25^\circ\text{C}$ ,  $V_{DD} = 5V$  (unless otherwise noted)

PARAMETER		TEST CONDITIONS	TA	MIN	TYP	MAX	UNIT
<b>DYNAMIC CHARACTERISTICS</b>							
$t_{\text{TRAN}}$	Transition time between channels	$V_S = 3V$ $R_L = 200\ \Omega$ , $C_L = 15\text{pF}$ Refer to <a href="#">Transition time</a>	25°C		12		ns
			-40°C to +85°C			18	ns
			-40°C to +125°C			19	ns
$t_{\text{OPEN}}$ (BBM)	Break before make time (TMUX1113 Only)	$V_S = 3V$ $R_L = 200\ \Omega$ , $C_L = 15\text{pF}$ Refer to <a href="#">Break-before-make</a>	25°C		8		ns
			-40°C to +85°C		1		ns
			-40°C to +125°C		1		ns
$Q_C$	Charge Injection	$V_S = 1V$ $R_S = 0\ \Omega$ , $C_L = 1\text{nF}$ Refer to <a href="#">Charge injection</a>	25°C		-1.5		pC
$O_{\text{ISO}}$	Off Isolation	$R_L = 50\ \Omega$ , $C_L = 5\text{pF}$ $f = 1\text{MHz}$ Refer to <a href="#">Off isolation</a>	25°C		-62		dB
		$R_L = 50\ \Omega$ , $C_L = 5\text{pF}$ $f = 10\text{MHz}$ Refer to <a href="#">Off isolation</a>	25°C		-40		dB
$X_{\text{TALK}}$	Crosstalk	$R_L = 50\ \Omega$ , $C_L = 5\text{pF}$ $f = 1\text{MHz}$ Refer to <a href="#">Channel-to Channel Crosstalk</a>	25°C		-100		dB
		$R_L = 50\ \Omega$ , $C_L = 5\text{pF}$ $f = 10\text{MHz}$ Refer to <a href="#">Channel-to Channel Crosstalk</a>	25°C		-90		dB
BW	Bandwidth	$R_L = 50\ \Omega$ , $C_L = 5\text{pF}$ Refer to <a href="#">Bandwidth</a>	25°C		300		MHz
$C_{\text{SOFF}}$	Source off capacitance	$f = 1\text{MHz}$	25°C		7		pF
$C_{\text{DOFF}}$	Drain off capacitance	$f = 1\text{MHz}$	25°C		10		pF
$C_{\text{SON}}$ $C_{\text{DON}}$	On capacitance	$f = 1\text{MHz}$	25°C		17		pF

(1) When  $V_S$  is 4.5V,  $V_D$  is 1.5V or when  $V_S$  is 1.5V,  $V_D$  is 4.5V.

## 6.6 Electrical Characteristics ( $V_{DD} = 3.3V \pm 10\%$ )

at  $T_A = 25^\circ C$ ,  $V_{DD} = 3.3V$  (unless otherwise noted)

PARAMETER		TEST CONDITIONS	TA	MIN	TYP	MAX	UNIT
<b>ANALOG SWITCH</b>							
$R_{ON}$	On-resistance	$V_S = 0V$ to $V_{DD}$ $I_{SD} = 10mA$ Refer to <a href="#">On-resistance</a>	25°C		3.7	8.8	$\Omega$
			-40°C to +85°C			9.5	$\Omega$
			-40°C to +125°C			9.8	$\Omega$
$\Delta R_{ON}$	On-resistance matching between channels	$V_S = 0V$ to $V_{DD}$ $I_{SD} = 10mA$ Refer to <a href="#">On-resistance</a>	25°C		0.13		$\Omega$
			-40°C to +85°C			0.4	$\Omega$
			-40°C to +125°C			0.5	$\Omega$
$R_{ON}$ FLAT	On-resistance flatness	$V_S = 0V$ to $V_{DD}$ $I_{SD} = 10mA$ Refer to <a href="#">On-resistance</a>	25°C		1.9		$\Omega$
			-40°C to +85°C			2	$\Omega$
			-40°C to +125°C			2.2	$\Omega$
$I_{S(OFF)}$	Source off leakage current <sup>(1)</sup>	$V_{DD} = 3.3V$ Switch Off $V_D = 3V / 1V$ $V_S = 1V / 3V$ Refer to <a href="#">Off-leakage current</a>	25°C	-0.05	$\pm 0.001$	0.05	nA
			-40°C to +85°C			0.2	nA
			-40°C to +125°C			0.9	nA
$I_{D(OFF)}$	Drain off leakage current <sup>(1)</sup>	$V_{DD} = 3.3V$ Switch Off $V_D = 3V / 1V$ $V_S = 1V / 3V$ Refer to <a href="#">Off-leakage current</a>	25°C	-0.05	$\pm 0.001$	0.05	nA
			-40°C to +85°C			0.2	nA
			-40°C to +125°C			0.9	nA
$I_{D(ON)}$ $I_{S(ON)}$	Channel on leakage current	$V_{DD} = 3.3V$ Switch On $V_D = V_S = 3V / 1V$ Refer to <a href="#">On-leakage current</a>	25°C	-0.1	$\pm 0.005$	0.1	nA
			-40°C to +85°C			0.35	nA
			-40°C to +125°C			2	nA
<b>LOGIC INPUTS (SELx)</b>							
$V_{IH}$	Input logic high		-40°C to +125°C	1.35		5.5	V
$V_{IL}$	Input logic low		-40°C to +125°C	0		0.8	V
$I_{IH}$ $I_{IL}$	Input leakage current		25°C		$\pm 0.005$		$\mu A$
$I_{IH}$ $I_{IL}$	Input leakage current		-40°C to +125°C			$\pm 0.05$	$\mu A$
$C_{IN}$	Logic input capacitance		25°C		1		pF
$C_{IN}$	Logic input capacitance		-40°C to +125°C			2	pF
<b>POWER SUPPLY</b>							
$I_{DD}$	$V_{DD}$ supply current	Logic inputs = 0V or 5.5V	25°C		0.005		$\mu A$
			-40°C to +125°C			1	$\mu A$



## 6.6 Electrical Characteristics ( $V_{DD} = 3.3V \pm 10\%$ ) (continued)

at  $T_A = 25^\circ\text{C}$ ,  $V_{DD} = 3.3V$  (unless otherwise noted)

PARAMETER		TEST CONDITIONS	TA	MIN	TYP	MAX	UNIT
<b>DYNAMIC CHARACTERISTICS</b>							
$t_{\text{TRAN}}$	Transition time between channels	$V_S = 2V$ $R_L = 200\ \Omega$ , $C_L = 15\text{pF}$ Refer to <a href="#">Transition time</a>	25°C		14		ns
			-40°C to +85°C			20	ns
			-40°C to +125°C			22	ns
$t_{\text{OPEN}}$ (BBM)	Break before make time (TMUX1113 Only)	$V_S = 2V$ $R_L = 200\ \Omega$ , $C_L = 15\text{pF}$ Refer to <a href="#">Break-before-make</a>	25°C		9		ns
			-40°C to +85°C		1		ns
			-40°C to +125°C		1		ns
$Q_C$	Charge Injection	$V_S = 1V$ $R_S = 0\ \Omega$ , $C_L = 1\text{nF}$ Refer to <a href="#">Charge injection</a>	25°C		-1.5		pC
$O_{\text{ISO}}$	Off Isolation	$R_L = 50\ \Omega$ , $C_L = 5\text{pF}$ $f = 1\text{MHz}$ Refer to <a href="#">Off isolation</a>	25°C		-62		dB
		$R_L = 50\ \Omega$ , $C_L = 5\text{pF}$ $f = 10\text{MHz}$ Refer to <a href="#">Off Isolation</a>	25°C		-40		dB
$X_{\text{TALK}}$	Crosstalk	$R_L = 50\ \Omega$ , $C_L = 5\text{pF}$ $f = 1\text{MHz}$ Refer to <a href="#">Channel-to-Channel Crosstalk</a>	25°C		-100		dB
		$R_L = 50\ \Omega$ , $C_L = 5\text{pF}$ $f = 10\text{MHz}$ Refer to <a href="#">Channel-to-Channel Crosstalk</a>	25°C		-90		dB
BW	Bandwidth	$R_L = 50\ \Omega$ , $C_L = 5\text{pF}$ Refer to <a href="#">Bandwidth</a>	25°C		300		MHz
$C_{\text{SOFF}}$	Source off capacitance	$f = 1\text{MHz}$	25°C		7		pF
$C_{\text{DOFF}}$	Drain off capacitance	$f = 1\text{MHz}$	25°C		10		pF
$C_{\text{SON}}$ $C_{\text{DON}}$	On capacitance	$f = 1\text{MHz}$	25°C		17		pF

(1) When  $V_S$  is 3V,  $V_D$  is 1V or when  $V_S$  is 1V,  $V_D$  is 3V.

## 6.7 Electrical Characteristics (V<sub>DD</sub> = 1.8V ±10 %)

at T<sub>A</sub> = 25°C, V<sub>DD</sub> = 1.8V (unless otherwise noted)

PARAMETER		TEST CONDITIONS	TA	MIN	TYP	MAX	UNIT	
<b>ANALOG SWITCH</b>								
R <sub>ON</sub>	On-resistance	V <sub>S</sub> = 0V to V <sub>DD</sub> I <sub>SD</sub> = 10mA Refer to <a href="#">On-resistance</a>	25°C		40		Ω	
			-40°C to +85°C			80	Ω	
			-40°C to +125°C			80	Ω	
ΔR <sub>ON</sub>	On-resistance matching between channels	V <sub>S</sub> = 0V to V <sub>DD</sub> I <sub>SD</sub> = 10mA Refer to <a href="#">On-resistance</a>	25°C		0.4		Ω	
			-40°C to +85°C			1.5	Ω	
			-40°C to +125°C			1.5	Ω	
I <sub>S(OFF)</sub>	Source off leakage current <sup>(1)</sup>	V <sub>DD</sub> = 1.98V Switch Off V <sub>D</sub> = 1.62V / 1V V <sub>S</sub> = 1V / 1.62V Refer to <a href="#">Off-leakage current</a>	25°C	-0.05	±0.001	0.05	nA	
			-40°C to +85°C		-0.2		0.2	nA
			-40°C to +125°C		-0.9		0.9	nA
I <sub>D(OFF)</sub>	Drain off leakage current <sup>(1)</sup>	V <sub>DD</sub> = 1.98V Switch Off V <sub>D</sub> = 1.62V / 1V V <sub>S</sub> = 1V / 1.62V Refer to <a href="#">Off-leakage current</a>	25°C	-0.05	±0.001	0.05	nA	
			-40°C to +85°C		-0.2		0.2	nA
			-40°C to +125°C		-0.9		0.9	nA
I <sub>D(ON)</sub> I <sub>S(ON)</sub>	Channel on leakage current	V <sub>DD</sub> = 1.98V Switch On V <sub>D</sub> = V <sub>S</sub> = 1.62V / 1V Refer to <a href="#">On-leakage current</a>	25°C	-0.1	±0.005	0.1	nA	
			-40°C to +85°C		-0.35		0.35	nA
			-40°C to +125°C		-2		2	nA
<b>LOGIC INPUTS (SELx)</b>								
V <sub>IH</sub>	Input logic high		-40°C to +125°C	1.07		5.5	V	
V <sub>IL</sub>	Input logic low		-40°C to +125°C	0		0.68	V	
I <sub>IH</sub> I <sub>IL</sub>	Input leakage current		25°C		±0.005		μA	
I <sub>IH</sub> I <sub>IL</sub>	Input leakage current		-40°C to +125°C			±0.05	μA	
C <sub>IN</sub>	Logic input capacitance		25°C		1		pF	
C <sub>IN</sub>	Logic input capacitance		-40°C to +125°C			2	pF	
<b>POWER SUPPLY</b>								
I <sub>DD</sub>	V <sub>DD</sub> supply current	Logic inputs = 0V or 5.5V	25°C		0.001		μA	
			-40°C to +125°C			0.85	μA	

## 6.7 Electrical Characteristics ( $V_{DD} = 1.8V \pm 10\%$ ) (continued)

at  $T_A = 25^\circ\text{C}$ ,  $V_{DD} = 1.8V$  (unless otherwise noted)

PARAMETER		TEST CONDITIONS	TA	MIN	TYP	MAX	UNIT
<b>DYNAMIC CHARACTERISTICS</b>							
$t_{\text{TRAN}}$	Transition time between channels	$V_S = 1V$ $R_L = 200\ \Omega$ , $C_L = 15\text{pF}$ Refer to <a href="#">Transition time</a>	25°C		25		ns
			-40°C to +85°C			44	ns
			-40°C to +125°C			44	ns
$t_{\text{OPEN}}$ (BBM)	Break before make time (TMUX1113 Only)	$V_S = 1V$ $R_L = 200\ \Omega$ , $C_L = 15\text{pF}$ Refer to <a href="#">Break-before-make</a>	25°C		17		ns
			-40°C to +85°C		1		ns
			-40°C to +125°C		1		ns
$Q_C$	Charge Injection	$V_S = 1V$ $R_S = 0\ \Omega$ , $C_L = 1\text{nF}$ Refer to <a href="#">Charge injection</a>	25°C		-0.5		pC
$O_{\text{ISO}}$	Off Isolation	$R_L = 50\ \Omega$ , $C_L = 5\text{pF}$ $f = 1\text{MHz}$ Refer to <a href="#">Off isolation</a>	25°C		-62		dB
		$R_L = 50\ \Omega$ , $C_L = 5\text{pF}$ $f = 10\text{MHz}$ Refer to <a href="#">Off isolation</a>	25°C		-40		dB
$X_{\text{TALK}}$	Crosstalk	$R_L = 50\ \Omega$ , $C_L = 5\text{pF}$ $f = 1\text{MHz}$ Refer to <a href="#">Channel-to-Channel Crosstalk</a>	25°C		-100		dB
		$R_L = 50\ \Omega$ , $C_L = 5\text{pF}$ $f = 10\text{MHz}$ Refer to <a href="#">Channel-to-Channel Crosstalk</a>	25°C		-90		dB
BW	Bandwidth	$R_L = 50\ \Omega$ , $C_L = 5\text{pF}$ Refer to <a href="#">Bandwidth</a>	25°C		300		MHz
$C_{\text{SOFF}}$	Source off capacitance	$f = 1\text{MHz}$	25°C		7		pF
$C_{\text{DOFF}}$	Drain off capacitance	$f = 1\text{MHz}$	25°C		10		pF
$C_{\text{SON}}$ $C_{\text{DON}}$	On capacitance	$f = 1\text{MHz}$	25°C		17		pF

(1) When  $V_S$  is 1.62V,  $V_D$  is 1V or when  $V_S$  is 1V,  $V_D$  is 1.62V.

### 6.8 Electrical Characteristics ( $V_{DD} = 1.2V \pm 10\%$ )

PARAMETER		TEST CONDITIONS	TA	MIN	TYP	MAX	UNIT
<b>ANALOG SWITCH</b>							
$R_{ON}$	On-resistance	$V_S = 0V$ to $V_{DD}$ $I_{SD} = 10mA$ Refer to <a href="#">On-resistance</a>	25°C	70			$\Omega$
			-40°C to +85°C			105	$\Omega$
			-40°C to +125°C			105	$\Omega$
$\Delta R_{ON}$	On-resistance matching between channels	$V_S = 0V$ to $V_{DD}$ $I_{SD} = 10mA$ Refer to <a href="#">On-resistance</a>	25°C	0.4			$\Omega$
			-40°C to +85°C			1.5	$\Omega$
			-40°C to +125°C			1.5	$\Omega$
$I_{S(OFF)}$	Source off leakage current <sup>(1)</sup>	$V_{DD} = 1.32V$ Switch Off $V_D = 1V / 0.8V$ $V_S = 0.8V / 1V$ Refer to <a href="#">Off-leakage current</a>	25°C	-0.05	$\pm 0.001$	0.05	nA
			-40°C to +85°C	-0.2		0.2	nA
			-40°C to +125°C	-0.9		0.9	nA
$I_{D(OFF)}$	Drain off leakage current <sup>(1)</sup>	$V_{DD} = 1.32V$ Switch Off $V_D = 1V / 0.8V$ $V_S = 0.8V / 1V$ Refer to <a href="#">Off-leakage current</a>	25°C	-0.05	$\pm 0.001$	0.05	nA
			-40°C to +85°C	-0.2		0.2	nA
			-40°C to +125°C	-0.9		0.9	nA
$I_{D(ON)}$ $I_{S(ON)}$	Channel on leakage current	$V_{DD} = 1.32V$ Switch On $V_D = V_S = 1V / 0.8V$ Refer to <a href="#">On-leakage current</a>	25°C	-0.1	$\pm 0.005$	0.1	nA
			-40°C to +85°C	-0.35		0.35	nA
			-40°C to +125°C	-2		2	nA
<b>LOGIC INPUTS (SELx)</b>							
$V_{IH}$	Input logic high		-40°C to +125°C	0.96		5.5	V
$V_{IL}$	Input logic low		-40°C to +125°C	0		0.36	V
$I_{IH}$ $I_{IL}$	Input leakage current		25°C	$\pm 0.005$			$\mu A$
			-40°C to +125°C			$\pm 0.05$	$\mu A$
$C_{IN}$	Logic input capacitance		25°C	1			pF
$C_{IN}$	Logic input capacitance		-40°C to +125°C			2	pF
<b>POWER SUPPLY</b>							
$I_{DD}$	$V_{DD}$ supply current	Logic inputs = 0V or 5.5V	25°C	0.001			$\mu A$
			-40°C to +125°C			0.7	$\mu A$

## 6.8 Electrical Characteristics ( $V_{DD} = 1.2V \pm 10\%$ ) (continued)

PARAMETER		TEST CONDITIONS	TA	MIN	TYP	MAX	UNIT	
<b>DYNAMIC CHARACTERISTICS</b>								
$t_{TRAN}$	Transition time between channels	$V_S = 1V$ $R_L = 200\ \Omega$ , $C_L = 15pF$ Refer to <a href="#">Transition time</a>	25°C		55		ns	
			-40°C to +85°C			190		ns
			-40°C to +125°C			190		ns
$t_{OPEN}$ (BBM)	Break before make time (TMUX1113 Only)	$V_S = 1V$ $R_L = 200\ \Omega$ , $C_L = 15pF$ Refer to <a href="#">Break-before-make</a>	25°C		28		ns	
			-40°C to +85°C		1		ns	
			-40°C to +125°C		1		ns	
$Q_C$	Charge Injection	$V_S = 1V$ $R_S = 0\ \Omega$ , $C_L = 1nF$ Refer to <a href="#">Charge injection</a>	25°C		-0.5		pC	
$O_{ISO}$	Off Isolation	$R_L = 50\ \Omega$ , $C_L = 5pF$ $f = 1MHz$ Refer to <a href="#">Off isolation</a>	25°C		-62		dB	
		$R_L = 50\ \Omega$ , $C_L = 5pF$ $f = 10MHz$ Refer to <a href="#">Off isolation</a>	25°C		-40		dB	
$X_{TALK}$	Crosstalk	$R_L = 50\ \Omega$ , $C_L = 5pF$ $f = 1MHz$ Refer to <a href="#">Channel-to-Channel Crosstalk</a>	25°C		-100		dB	
		$R_L = 50\ \Omega$ , $C_L = 5pF$ $f = 10MHz$ Refer to <a href="#">Channel-to-Channel Crosstalk</a>	25°C		-90		dB	
BW	Bandwidth	$R_L = 50\ \Omega$ , $C_L = 5pF$ Refer to <a href="#">Bandwidth</a>	25°C		300		MHz	
$C_{SOFF}$	Source off capacitance	$f = 1MHz$	25°C		8		pF	
$C_{DOFF}$	Drain off capacitance	$f = 1MHz$	25°C		11		pF	
$C_{SON}$ $C_{DON}$	On capacitance	$f = 1MHz$	25°C		18		pF	

(1) When  $V_S$  is 1V,  $V_D$  is 0.8V or when  $V_S$  is 0.8V,  $V_D$  is 1V.

## 6.9 Typical Characteristics

at  $T_A = 25^\circ\text{C}$ ,  $V_{DD} = 5\text{V}$  (unless otherwise noted)

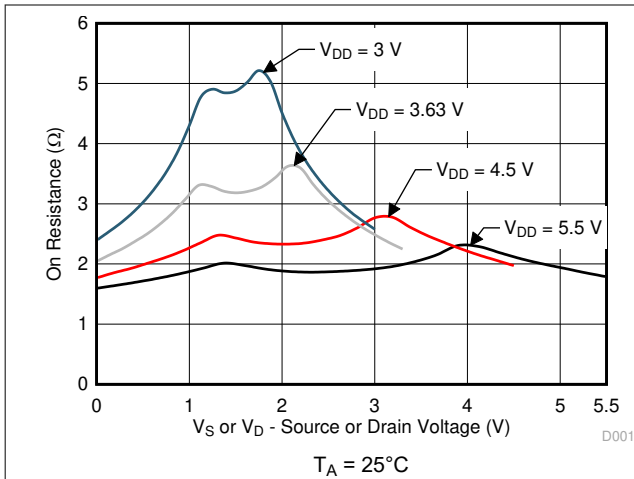

Figure 6-1. On-Resistance vs Source or Drain Voltage

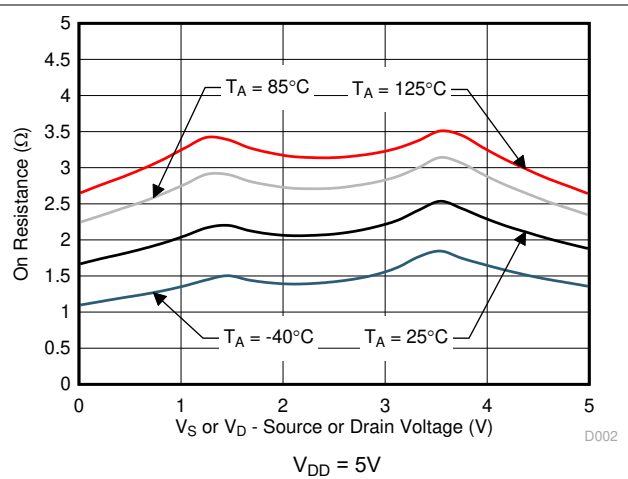

Figure 6-2. On-Resistance vs Temperature

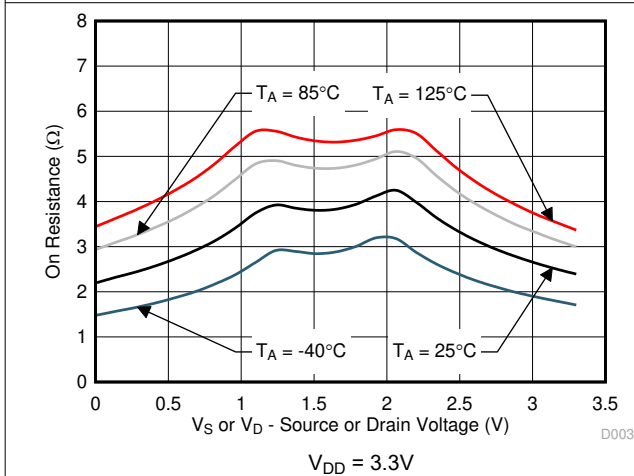

Figure 6-3. On-Resistance vs Temperature

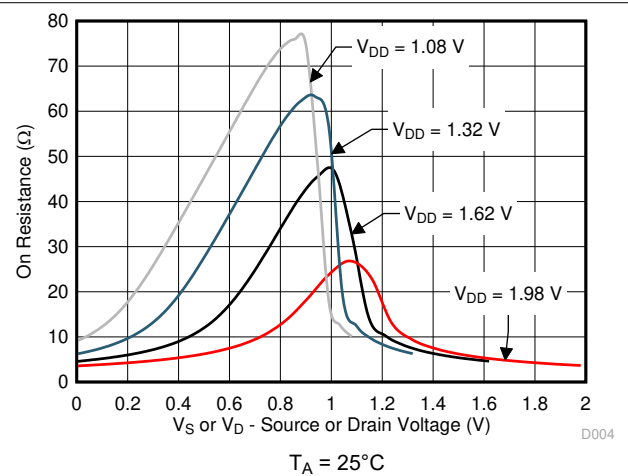

Figure 6-4. On-Resistance vs Source or Drain Voltage

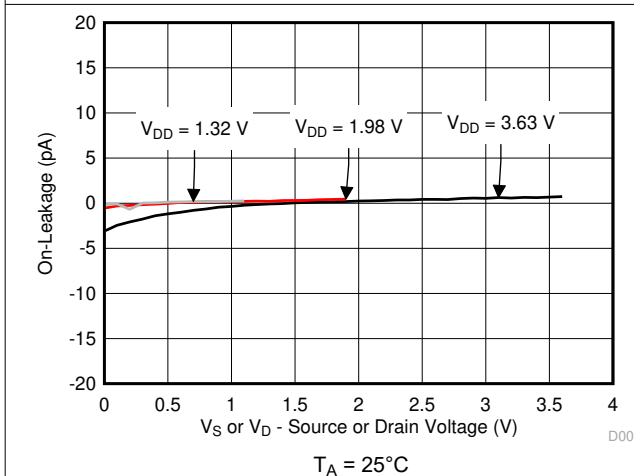

Figure 6-5. On-Leakage vs Source or Drain Voltage

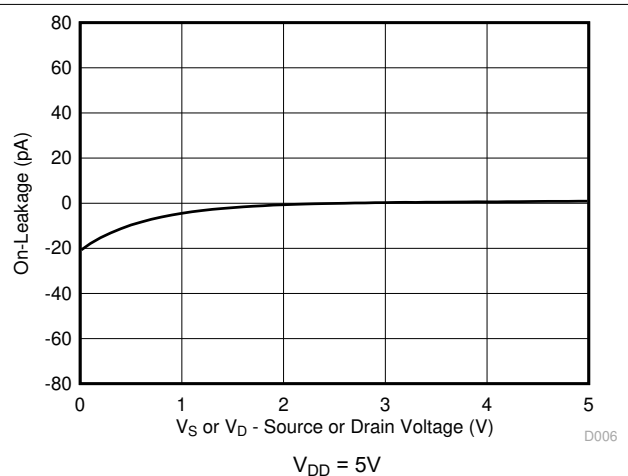
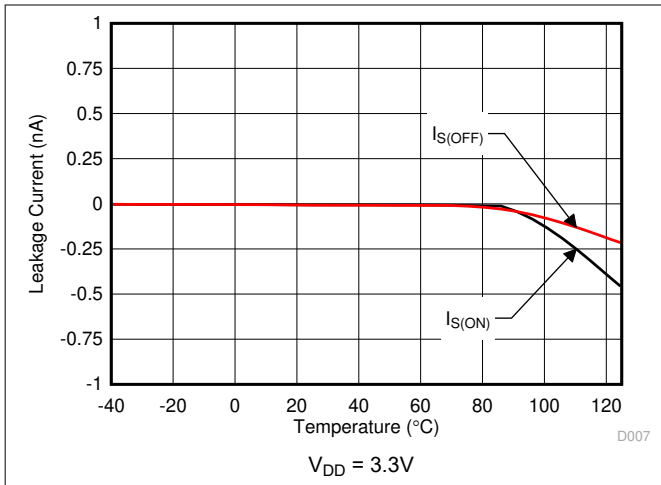

Figure 6-6. On-Leakage vs Source or Drain Voltage

### 6.9 Typical Characteristics (continued)

at  $T_A = 25^\circ\text{C}$ ,  $V_{DD} = 5\text{V}$  (unless otherwise noted)



**Figure 6-7. Leakage Current vs Temperature**

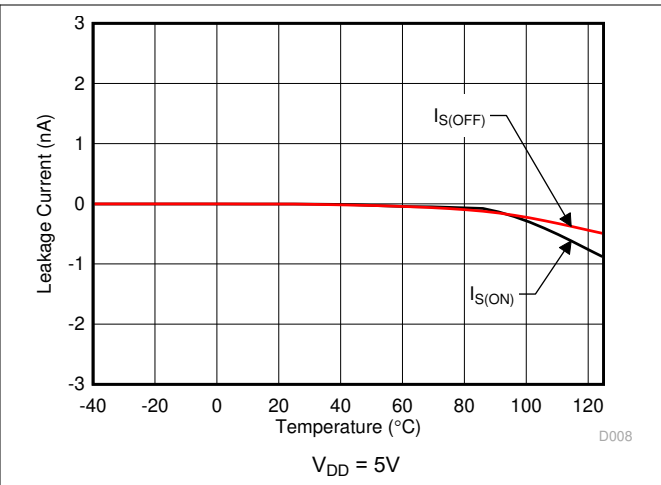

**Figure 6-8. Leakage Current vs Temperature**

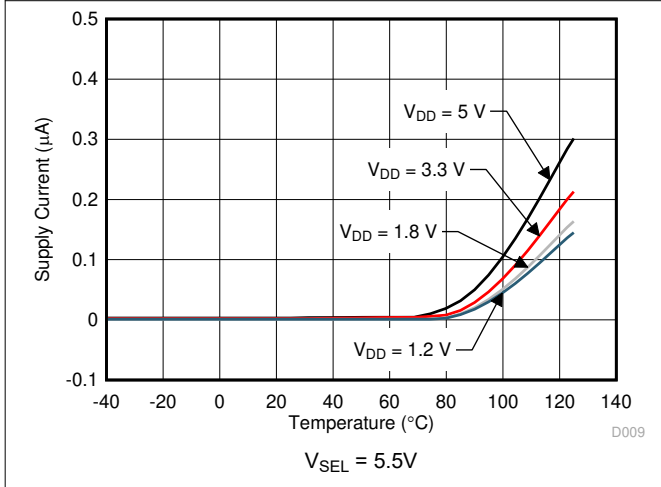

**Figure 6-9. Supply Current vs Temperature**

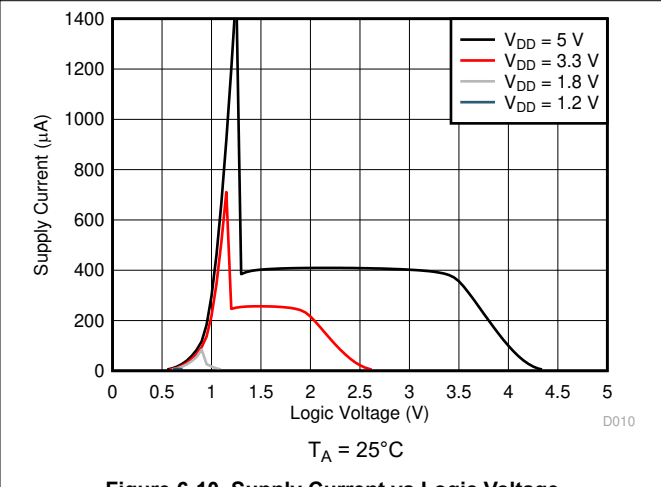

**Figure 6-10. Supply Current vs Logic Voltage**

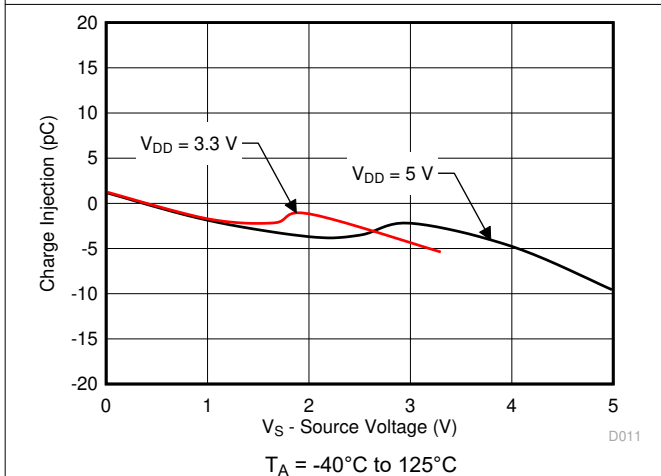

**Figure 6-11. Charge Injection vs Source Voltage**

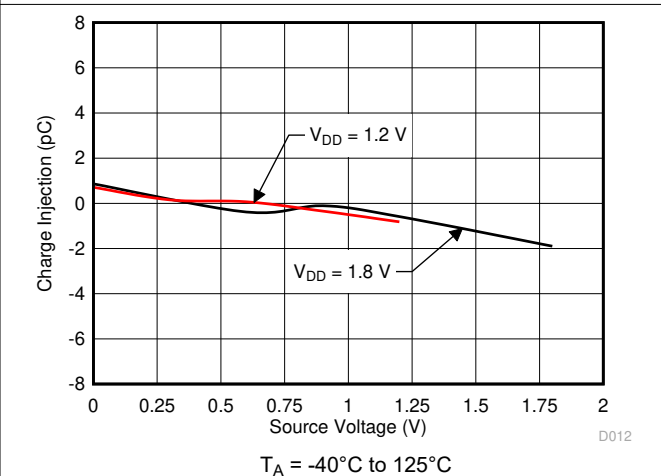

**Figure 6-12. Charge Injection vs Source Voltage**

## 6.9 Typical Characteristics (continued)

at  $T_A = 25^\circ\text{C}$ ,  $V_{DD} = 5\text{V}$  (unless otherwise noted)

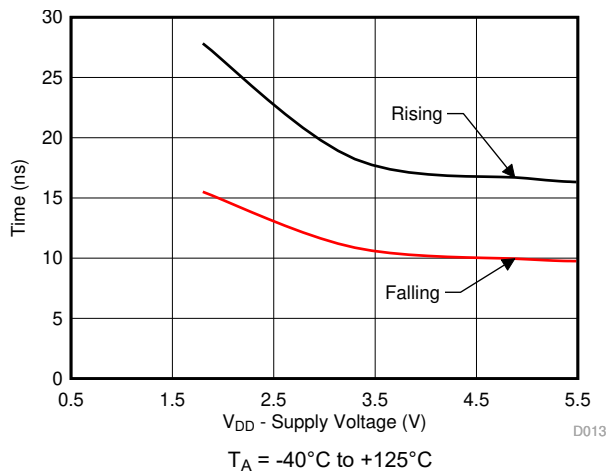

**Figure 6-13. Output  $T_{\text{TRANSITION}}$  vs Supply Voltage**

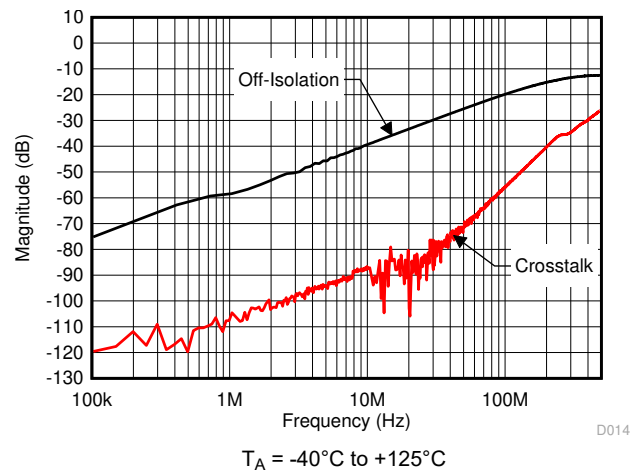

**Figure 6-14. Xtalk and Off-Isolation vs Frequency**

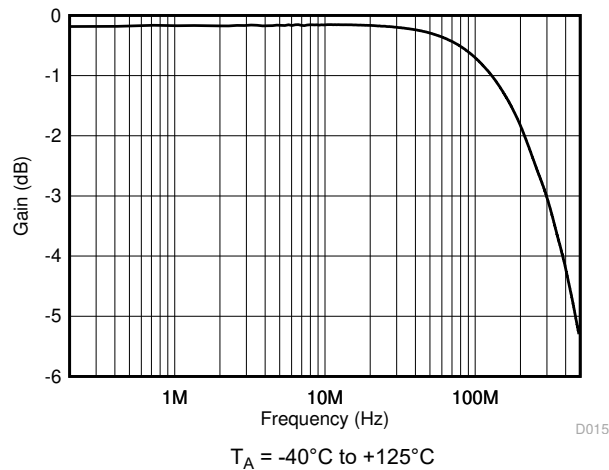

**Figure 6-15. On Response vs Frequency**



## 7 Parameter Measurement Information

### 7.1 On-resistance

The on-resistance of a device is the ohmic resistance between the source (Sx) and drain (Dx) pins of the device. The on-resistance varies with input voltage and supply voltage. The symbol  $R_{ON}$  is used to denote on-resistance. The measurement setup used to measure  $R_{ON}$  is shown in Figure 7-1. Voltage (V) and current ( $I_{SD}$ ) are measured using this setup, and  $R_{ON}$  is computed with  $R_{ON} = V / I_{SD}$ :

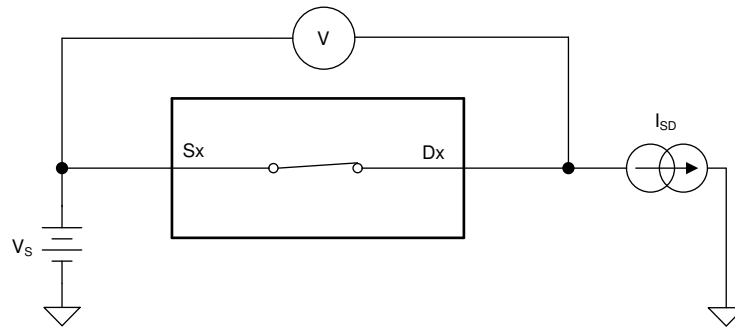

**Figure 7-1. On-Resistance Measurement Setup**

### 7.2 Off-leakage current

There are two types of leakage currents associated with a switch during the off state:

1. Source off-leakage current
2. Drain off-leakage current

Source leakage current is defined as the leakage current flowing into or out of the source pin when the switch is off. This current is denoted by the symbol  $I_{S(OFF)}$ .

Drain leakage current is defined as the leakage current flowing into or out of the drain pin when the switch is off. This current is denoted by the symbol  $I_{D(OFF)}$ .

The setup used to measure both off-leakage currents is shown in Figure 7-2.

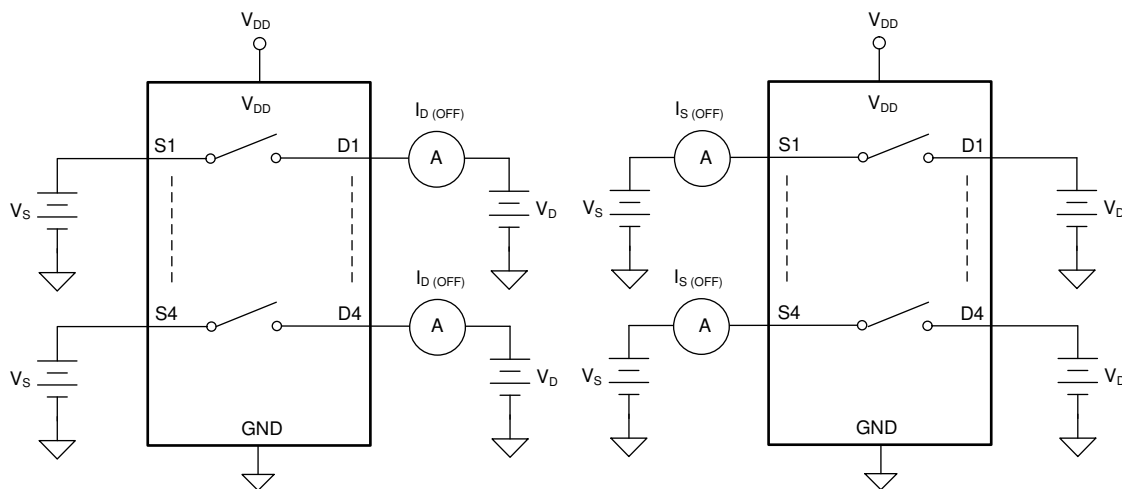

**Figure 7-2. Off-Leakage Measurement Setup**

### 7.3 On-leakage current

Source on-leakage current is defined as the leakage current flowing into or out of the source pin when the switch is on. This current is denoted by the symbol  $I_{S(ON)}$ .

Drain on-leakage current is defined as the leakage current flowing into or out of the drain pin when the switch is on. This current is denoted by the symbol  $I_{D(ON)}$ .

Either the source pin or drain pin is left floating during the measurement. Figure 7-3 shows the circuit used for measuring the on-leakage current, denoted by  $I_{S(ON)}$  or  $I_{D(ON)}$ .

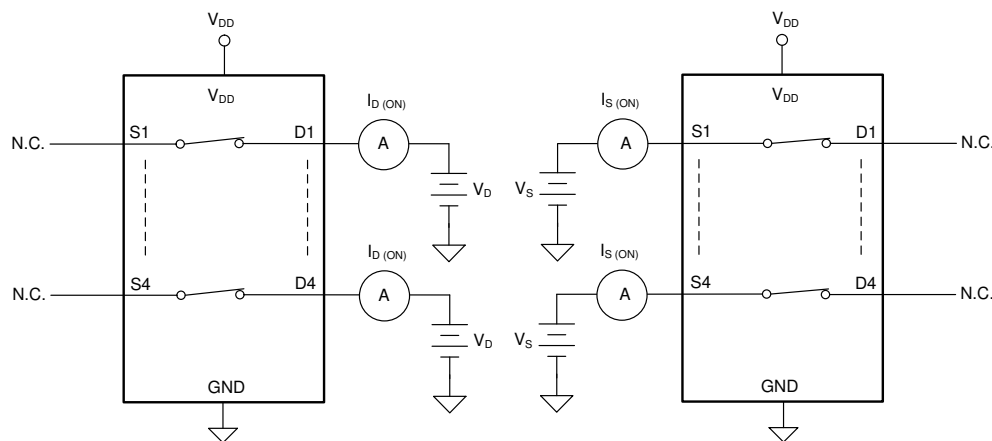

**Figure 7-3. On-Leakage Measurement Setup**

### 7.4 Transition time

Transition time is defined as the time taken by the output of the device to rise or fall 10% after the address signal has risen or fallen past the logic threshold. The 10% transition measurement is utilized to provide the timing of the device. System level timing can then account for the time constant added from the load resistance and load capacitance. Figure 7-4 shows the setup used to measure transition time, denoted by the symbol  $t_{\text{TRANSITION}}$ .

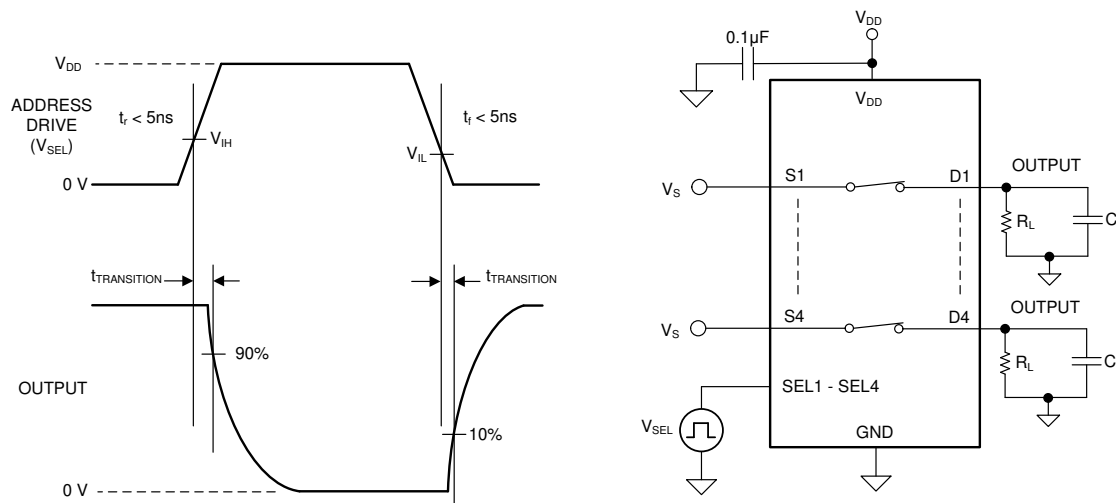

**Figure 7-4. Transition-Time Measurement Setup**

### 7.5 Break-before-make

The TMUX1113 has break-before-make delay which allows the device to be used in cross-point switching application. The output first breaks from the on-state switch before making the connection with the next on-state switch. The time delay between the *break* and the *make* is known as break-before-make delay. Figure 7-5 shows the setup used to measure break-before-make delay, denoted by the symbol  $t_{OPEN(BBM)}$ .

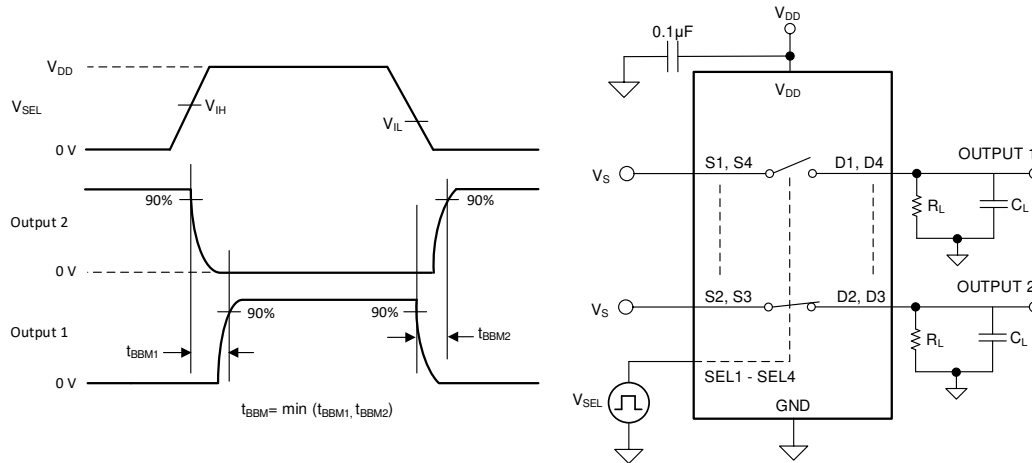

**Figure 7-5. Break-Before-Make Delay Measurement Setup**

### 7.6 Charge injection

The TMUX111x devices have a transmission-gate topology. Any mismatch in capacitance between the NMOS and PMOS transistors results in a charge injected into the drain or source during the falling or rising edge of the gate signal. The amount of charge injected into the source or drain of the device is known as charge injection, and is denoted by the symbol  $Q_C$ . Figure 7-6 shows the setup used to measure charge injection from source ( $S_x$ ) to drain ( $D_x$ ).

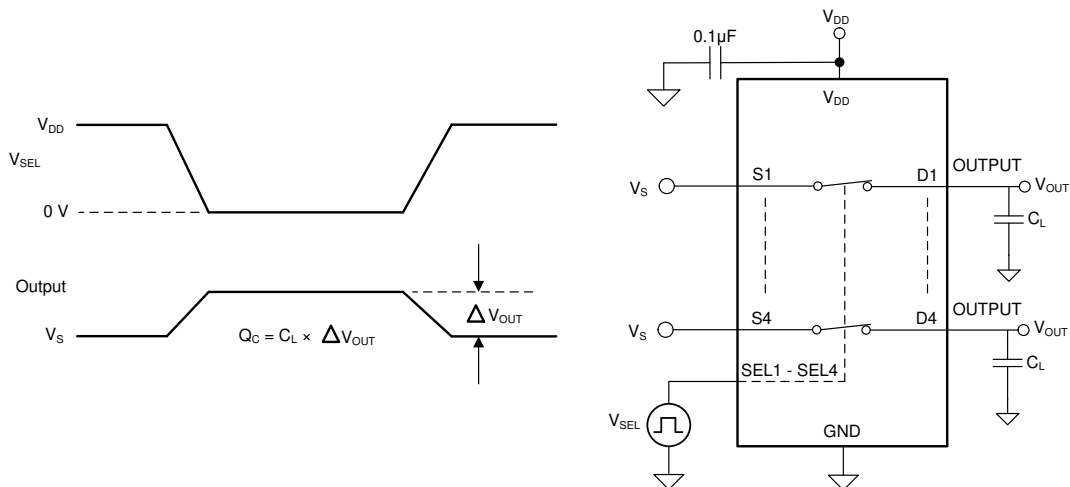

**Figure 7-6. Charge-Injection Measurement Setup**

## 7.7 Off isolation

Off isolation is defined as the ratio of the signal at the drain pin (Dx) of the device when a signal is applied to the source pin (Sx) of an off-channel. The characteristic impedance,  $Z_0$ , for the measurement is 50Ω. Figure 7-7 shows the setup used to measure off isolation. Use off isolation equation to compute off isolation.

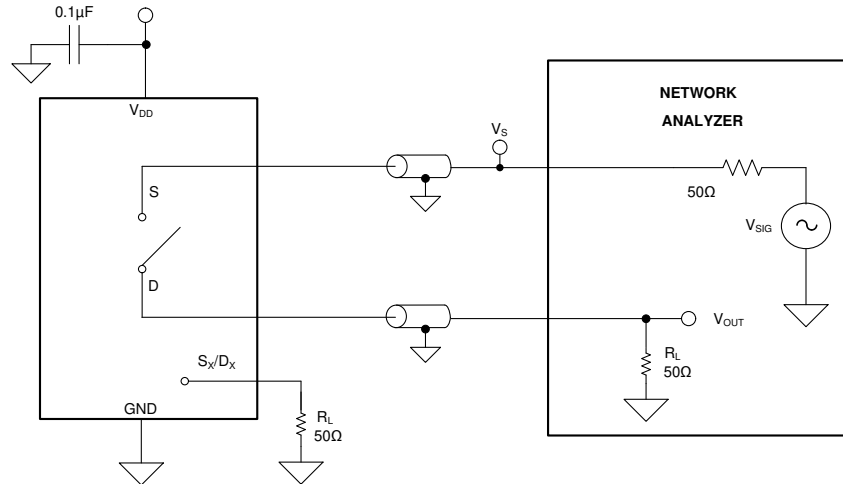
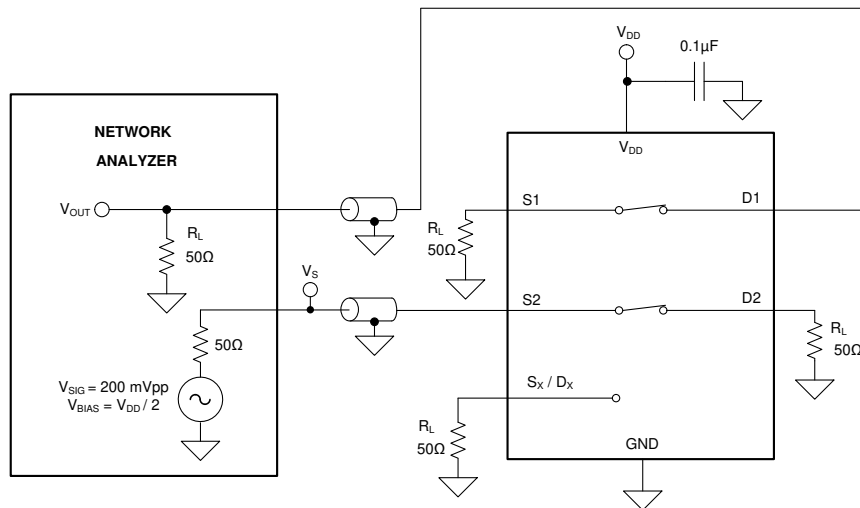

**Figure 7-7. Off Isolation Measurement Setup**

$$\text{Off Isolation} = 20 \cdot \text{Log} \left( \frac{V_{\text{OUT}}}{V_{\text{S}}} \right) \quad (1)$$

## 7.8 Channel-to-Channel Crosstalk

Crosstalk is defined as the ratio of the signal at the drain pin (Dx) of a different channel, when a signal is applied at the source pin (Sx) of an on-channel. The characteristic impedance,  $Z_0$ , for the measurement is 50Ω. Figure 7-8 shows the setup used to measure, and the equation used to compute crosstalk.

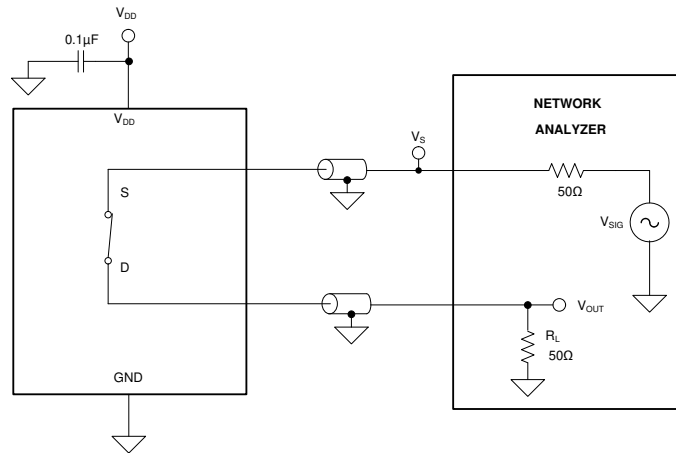

**Figure 7-8. Channel-to-Channel Crosstalk Measurement Setup**

$$\text{Channel-to-Channel Crosstalk} = 20 \cdot \text{Log} \left( \frac{V_{\text{OUT}}}{V_{\text{S}}} \right) \quad (2)$$

### 7.9 Bandwidth

Bandwidth is defined as the range of frequencies that are attenuated by less than 3dB when the input is applied to the source pin (Sx) of an on-channel, and the output is measured at the drain pin (Dx) of the device. The characteristic impedance,  $Z_0$ , for the measurement is 50Ω. Figure 7-9 shows the setup used to measure bandwidth.



**Figure 7-9. Bandwidth measurement setup**

## 8 Detailed Description

### 8.1 Overview

The TMUX1111, TMUX1112, and TMUX1113 are 1:1 (SPST), 4-Channel switches. The devices have four independently selectable single-pole, single-throw switches that are turned-on or turned-off based on the state of the corresponding select pin.

### 8.2 Functional Block Diagram

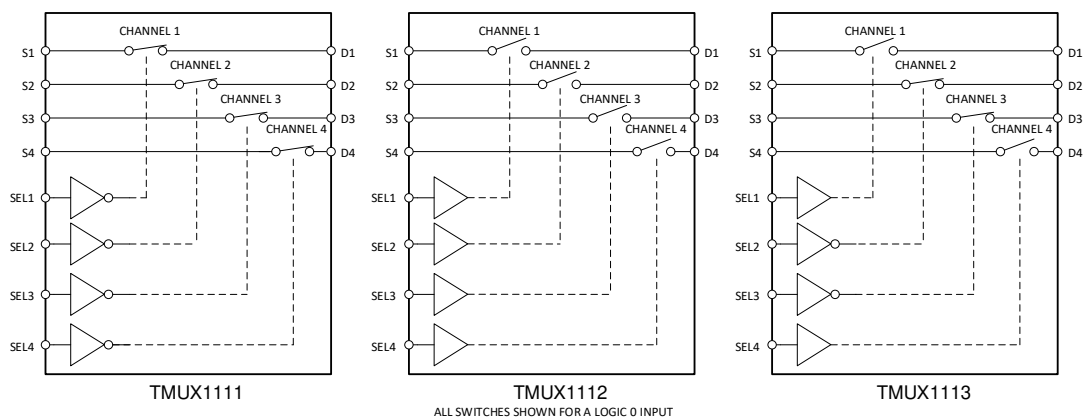

**Figure 8-1. TMUX111x Functional Block Diagram**

### 8.3 Feature Description

#### 8.3.1 Bidirectional operation

The TMUX111x conducts equally well from source ( $S_x$ ) to drain ( $D_x$ ) or from drain ( $D_x$ ) to source ( $S_x$ ). Each channel has very similar characteristics in both directions and supports both analog and digital signals.

#### 8.3.2 Rail to rail operation

The valid signal path input/output voltage for TMUX111x ranges from GND to  $V_{DD}$ .

#### 8.3.3 1.8V Logic compatible inputs

The TMUX111x devices have 1.8V logic compatible control for all logic control inputs. The logic input thresholds scale with supply but still provide 1.8V logic control when operating at 5.5V supply voltage. 1.8V logic level inputs allows the TMUX111x devices to interface with processors that have lower logic I/O rails and eliminates the need for an external translator, which saves both space and BOM cost. The current consumption of the TMUX111x devices increase when using 1.8V logic with higher supply voltage as shown in [Figure 6-10](#). For more information on 1.8V logic implementations refer to [Simplifying Design with 1.8V Logic Muxes and Switches](#)

#### 8.3.4 Fail-safe logic

The TMUX111x supports Fail-Safe Logic on the control input pins (EN, A0, A1) allowing for operation up to 5.5V, regardless of the state of the supply pin. This feature allows voltages on the control pins to be applied before the supply pin, protecting the device from potential damage. Fail-Safe Logic minimizes system complexity by removing the need for power supply sequencing on the logic control pins. For example, the Fail-Safe Logic feature allows the select pins of the TMUX111x to be ramped to 5.5V while  $V_{DD} = 0V$ . Additionally, the feature enables operation of the TMUX111x with  $V_{DD} = 1.2V$  while allowing the select pins to interface with a logic level of another device up to 5.5V.

#### 8.3.5 Ultra-Low Leakage Current

The TMUX111x devices provide extremely low on-leakage and off-leakage currents. The TMUX111x devices are capable of switching signals from high source-impedance inputs into a high input-impedance op amp with minimal offset error because of the ultra-low leakage currents. [Figure 8-2](#) shows typical leakage currents of the TMUX111x devices versus temperature at  $V_{DD} = 5V$ .

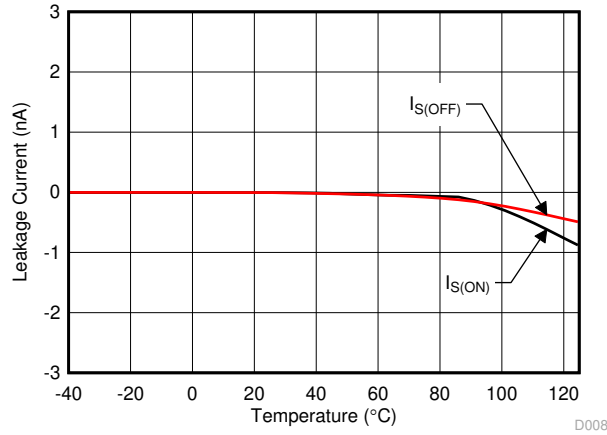
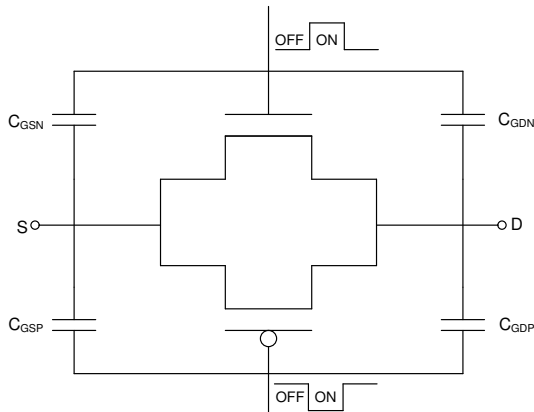

**Figure 8-2. Leakage Current vs Temperature**

### 8.3.6 Ultra-Low Charge Injection

The TMUX111x devices have a transmission gate topology, as shown in [Figure 8-3](#). Any mismatch in the stray capacitance associated with the NMOS and PMOS causes an output level change whenever the switch is opened or closed.

The TMUX111x devices have special charge-injection cancellation circuitry that reduces the source-to-drain charge injection to  $-1.5\text{pC}$  at  $V_S = 1\text{V}$  as shown in [Figure 8-4](#).



**Figure 8-3. Transmission Gate Topology**

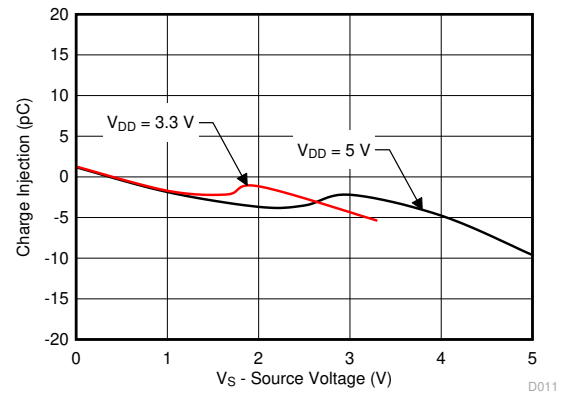

**Figure 8-4. Charge Injection vs Source Voltage**

## 8.4 Device Functional Modes

The TMUX111x devices have four independently selectable single-pole, single-throw switches that are turned-on or turned-off based on the state of the corresponding select pin. The control pins can be as high as 5.5V.

The TMUX111x devices can be operated without any external components except for the supply decoupling capacitors. Unused logic control pins should be tied to GND or V<sub>DD</sub> so that the device does not consume additional current as highlighted in *Implications of Slow or Floating CMOS Inputs*. Unused signal path inputs (Sx or Dx) should be connection to GND.

## 8.5 Truth Tables

Table 8-1, Table 8-2, and Table 8-3 provides the truth tables for the TMUX1111, TMUX1112, and TMUX1113, respectively.

**Table 8-1. TMUX1111 Truth Table<sup>(1)</sup>**

SEL x	CHANNEL x
0	Channel x ON
1	Channel x OFF

**Table 8-2. TMUX1112 Truth Table**

SEL x	CHANNEL x
0	Channel x OFF
1	Channel x ON

(1) x denotes 1, 2, 3, or 4 for the corresponding channel.

**Table 8-3. TMUX1113 Truth Table<sup>(1)</sup>**

SEL1	SEL2	SEL3	SEL4	ON / OFF CHANNELS
0	X	X	X	CHANNEL 1 OFF
1	X	X	X	CHANNEL 1 ON
X	0	X	X	CHANNEL 2 ON
X	1	X	X	CHANNEL 2 OFF
X	X	0	X	CHANNEL 3 ON
X	X	1	X	CHANNEL 3 OFF
X	X	X	0	CHANNEL 4 OFF
X	X	X	1	CHANNEL 4 ON

(1) X denotes *do not care*.



## 9 Application and Implementation

### Note

Information in the following applications sections is not part of the TI component specification, and TI does not warrant its accuracy or completeness. TI's customers are responsible for determining suitability of components for their purposes, as well as validating and testing their design implementation to confirm system functionality.

### 9.1 Application Information

The TMUX11xx family offers ultra-low input/output leakage currents and low charge injection. These devices operate up to 5.5V, and offer true rail-to-rail input and output of both analog and digital signals. The TMUX11xx have a low on-capacitance which allows faster settling time when multiplexing inputs in the time domain. These features make the TMUX11xx devices a family of precision, high-performance switches and multiplexers for low-voltage applications.

### 9.2 Typical Application - Sample-and-Hold Circuit

One useful application to take advantage of the TMUX1111, TMUX1112, and TMUX1113 performance is the sample-and-hold circuit. A sample-and-hold circuit can be useful for an analog to digital converter (ADC) to sample a varying input voltage with improved reliability and stability. It can also be used to store the output samples from a single digital-to-analog converter (DAC) in a multi-output application. A simple sample-and-hold circuit can be realized using an analog switch such as the TMUX1111, TMUX1112, and TMUX1113 analog switches. [Figure 9-1](#) shows a single channel sample-and hold circuit using only 1 of 4 channels in the TMUX11xx devices.

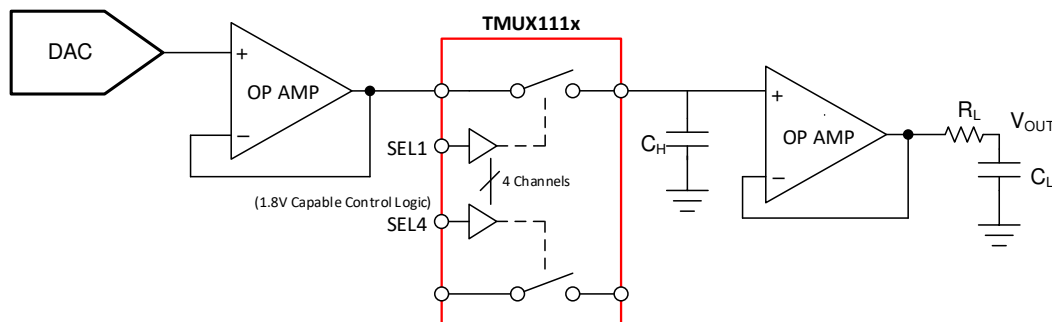

**Figure 9-1. Single Channel Sample-and-Hold Circuit Example**

An optional op amp is used before the switch since buffered DACs typically have limitations in driving capacitive loads. The additional buffer stage is included following the DAC to prevent potential stability problems from driving a large capacitive load.

Ideally, the switch delivers only the input signals to the holding capacitors. However, when the switch gets toggled, some amount of charge also gets transferred to the switch output in the form of charge injection, resulting in a pedestal sampling error. The TMUX1111, TMUX1112, and TMUX1113 switches have excellent charge injection performance of only -1.5pC, making them excellent choices for this implementation to minimize sampling error. The pedestal error voltage is indirectly related to the size of the capacitance on the output, for better precision a larger capacitor is required due to charge injection. Larger capacitance limits the system settling time which may not be acceptable in some applications. [Figure 9-2](#) shows a TMUX11xx device configured for a 2-channel sample-and-hold circuit with pedestal error compensation.

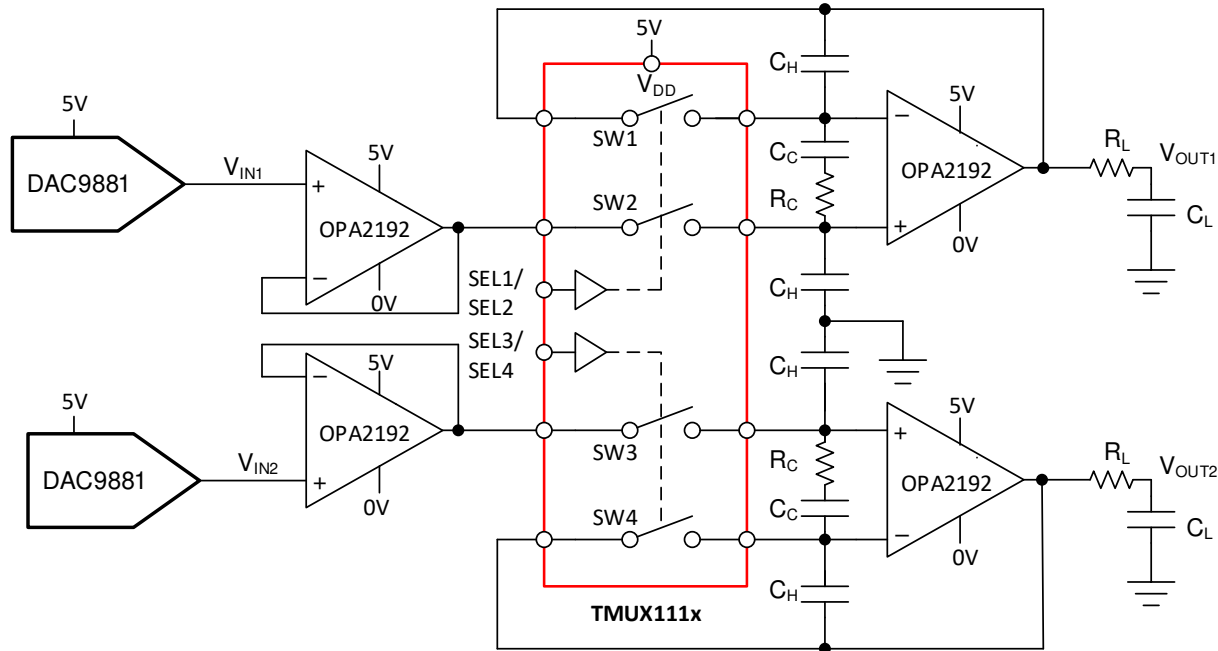

**Figure 9-2. 2-Channel Sample-and-Hold Circuit with Pedestal Error Compensation**

### 9.2.1 Design Requirements

The purpose of this precision design is to implement an optimized 2-output sample-and-hold circuit using a 4-channel SPST switch. The sample and hold circuit needs to be capable of supporting high accuracy with minimized pedestal error and fast settling time..

### 9.2.2 Detailed Design Procedure

#### 9.2.2.1 Detailed Design Procedure

The TMUX1111, TMUX1112, or TMUX1113 switch is used in conjunction with the voltage holding capacitors ( $C_H$ ) to implement the sample-and-hold circuit. The basic operation is:

1. When the switch (SW2 or SW3) is closed, it samples the input voltage and charges the holding capacitors ( $C_H$ ) to the input voltages values.
2. When the switch (SW2 or SW3) is open, the holding capacitors ( $C_H$ ) holds its previous value, maintaining stable voltage at the amplifier output ( $V_{OUT}$ ).

Due to switch and capacitor leakage current, as well as amplifier bias current, the voltage on the hold capacitors droops with time. The TMUX1111, TMUX1112, or TMUX1113 minimize the droops due to its ultra-low leakage performance. At 25°C, the TMUX1111, TMUX1112, and TMUX1113 have extremely low leakage current at 3pA typical.

A second switch SW1 (or SW4) is also included to operate in parallel with SW2 (or SW3) to reduce pedestal error during switch toggling. Because both switches are driven at the same potential, they act as common-mode signal to the op-amp, thereby minimizing the charge injection effects caused by the switch toggling action. Compensation network consisting of  $R_C$  and  $C_C$  is also added to further reduce the pedestal error, while reducing the hold-time glitch and improving the settling time of the circuit. Refer to [Sample and Hold Glitch Reduction for Precision Outputs Reference Design](#) for more information on sample-and-hold circuits.

### 9.2.3 Application Curve

TMUX1111, TMUX1112, and TMUX1113 have excellent charge injection performance and ultra-low leakage current, making them excellent choices to minimize sampling error for the sample and hold application.

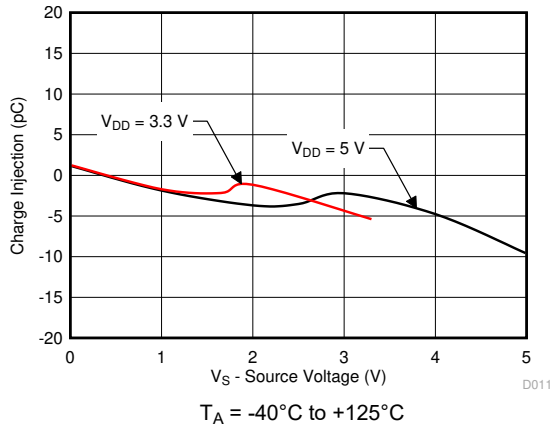

**Figure 9-3. Charge Injection vs Source Voltage**

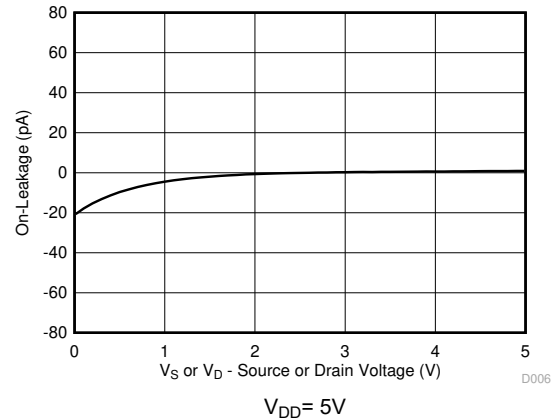

**Figure 9-4. On-Leakage vs Source or Drain Voltage**

### 9.3 Typical Application - Switched Gain Amplifier

Switches and multiplexers are commonly used in the feedback path of amplifier circuits to provide configurable gain control. By using various resistor values on each switch path the TMUX111x allows the system to have multiple gain settings. An external resistor, or utilizing 1 channel always being closed, causes the amplifier to not operate in an open loop configuration. A transimpedance amplifier (TIA) for photodiode inputs is a common circuit that requires gain control using a multi-channel switch to convert the output current of the photodiode into a voltage for the MCU or processor. The leakage current, capacitance, and charge injection performance of the TMUX111x are key specifications to evaluate when selecting a device for gain control.

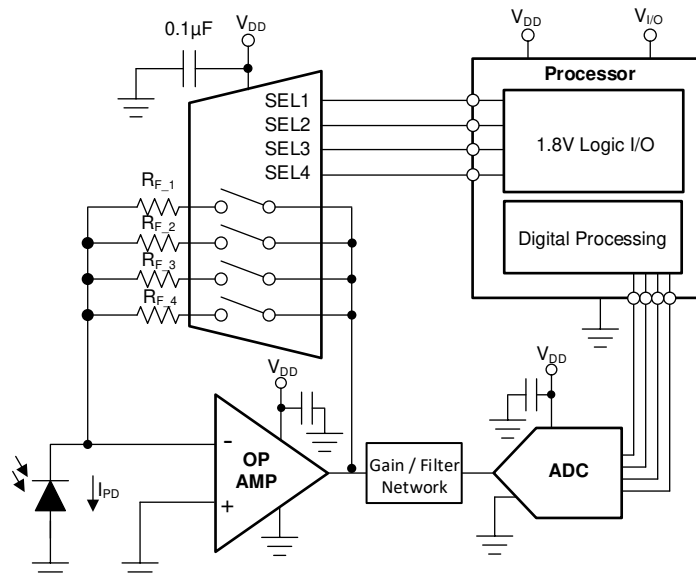

**Figure 9-5. Switching Gain Settings of a TIA circuit**

### 9.3.1 Design Requirements

For this design example, use the parameters listed in [Table 9-1](#).

**Table 9-1. Design parameters**

PARAMETERS	VALUES
Supply ( $V_{DD}$ )	3.3V
Input / Output signal range	0 $\mu$ A to 10 $\mu$ A
Control logic thresholds	1.8V compatible

### 9.3.2 Detailed Design Procedure

The TMUX111x devices can be operated without any external components except for the supply decoupling capacitors. All inputs signals passing through the switch must fall within the recommend operating conditions of the TMUX111x including signal range and continuous current. For this design example, with a supply of 3.3V, the signals can range from 0V to 3.3V when the device is powered. The max continuous current can be 30mA.

Photodiodes commonly have a current output that ranges from a few hundred picoamps to tens of microamps based on the amount of light being absorbed. The TMUX111x have a typical On-leakage current of less than 10pA which would lead to an accuracy well within 1% of a full scale 10 $\mu$ A signal. The low ON and OFF capacitance of the TMUX111x improves system stability by minimizing the total capacitance on the output of the amplifier. Lower capacitance leads to less overshoot and ringing in the system which can cause the amplifier circuit to go unstable if the phase margin is not at least 45°. Refer to [Improve Stability Issues with Low  \$C\_{ON}\$  Multiplexers](#) for more information on calculating the phase margin vs. percent overshoot.

### 9.3.3 Application Curve

The TMUX1111 is capable of switching signals from high source-impedance inputs into a high input-impedance op amp with minimal offset error because of the ultra-low leakage currents.

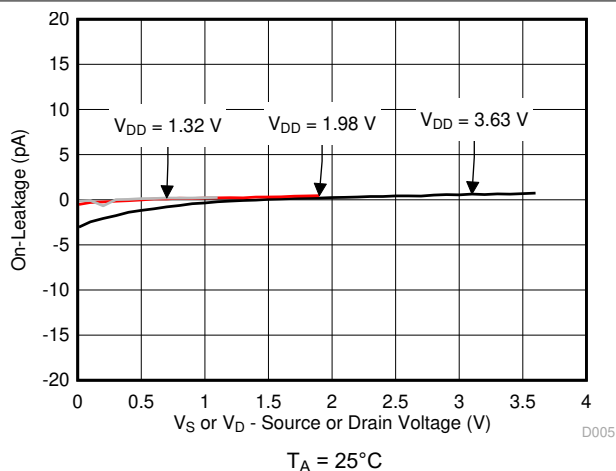

**Figure 9-6. On-Leakage vs Source or Drain Voltage**

## 9.4 Power Supply Recommendations

The TMUX111x operate across a wide supply range of 1.08V to 5.5V. Do not exceed the absolute maximum ratings because stresses beyond the listed ratings can cause permanent damage to the devices.

Power-supply bypassing improves noise margin and prevents switching noise propagation from the  $V_{DD}$  supply to other components. Good power-supply decoupling is important to achieve optimum performance. For improved supply noise immunity, use a supply decoupling capacitor ranging from 0.1  $\mu\text{F}$  to 10  $\mu\text{F}$  from  $V_{DD}$  to ground. Place the bypass capacitors as close to the power supply pins of the device as possible using low-impedance connections. TI recommends using multi-layer ceramic chip capacitors (MLCCs) that offer low equivalent series resistance (ESR) and inductance (ESL) characteristics for power-supply decoupling purposes. For very sensitive systems, or for systems in harsh noise environments, avoiding the use of vias for connecting the capacitors to the device pins may offer superior noise immunity. The use of multiple vias in parallel lowers the overall inductance and is beneficial for connections to ground planes.

## 9.5 Layout

### 9.5.1 Layout Guidelines

When a PCB trace turns a corner at a 90° angle, a reflection can occur. A reflection occurs primarily because of the change of width of the trace. At the apex of the turn, the trace width increases to 1.414 times the width. This increase upsets the transmission-line characteristics, especially the distributed capacitance and self-inductance of the trace which results in the reflection. Not all PCB traces can be straight and therefore some traces must turn corners. [Figure 9-7](#) shows progressively better techniques of rounding corners. Only the last example (BEST) maintains constant trace width and minimizes reflections.

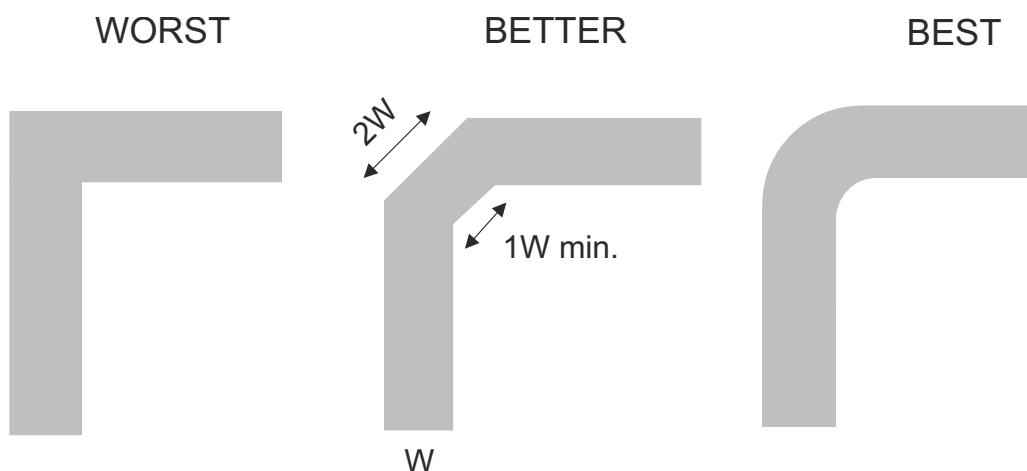

**Figure 9-7. Trace Example**

Route high-speed signals using a minimum of vias and corners which reduces signal reflections and impedance changes. When a via must be used, increase the clearance size around it to minimize its capacitance. Each via introduces discontinuities in the signal's transmission line and increases the chance of picking up interference from the other layers of the board. Be careful when designing test points, through-hole pins are not recommended at high frequencies.

## 9.5.2 Layout Example

Figure 9-8 shows an example of a PCB layout with the TMUX111x. Some key considerations are:

- Decouple the  $V_{DD}$  pin with a 0.1 $\mu$ F capacitor, placed as close to the pin as possible. Make sure that the capacitor voltage rating is sufficient for the  $V_{DD}$  supply.
- Keep the input lines as short as possible.
- Use a solid ground plane to help reduce electromagnetic interference (EMI) noise pickup.
- Do not run sensitive analog traces in parallel with digital traces. Avoid crossing digital and analog traces if possible, and only make perpendicular crossings when necessary.

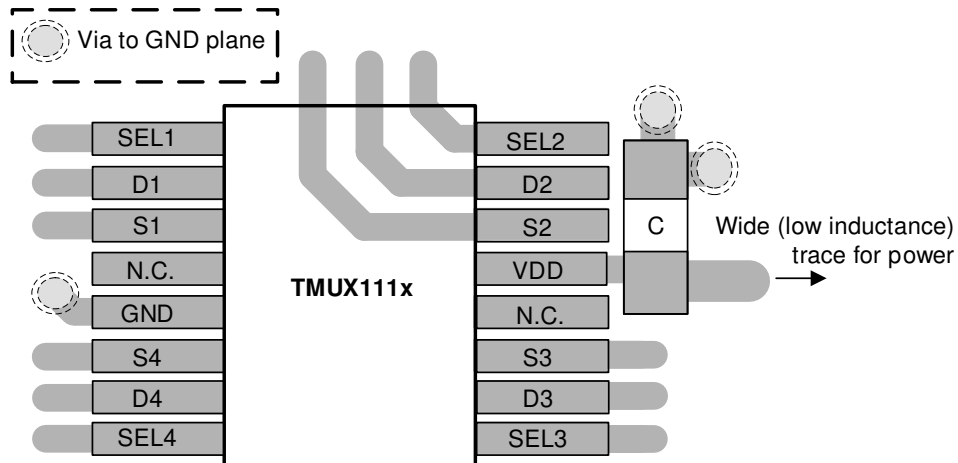

Figure 9-8. TMUX111x Layout Example

## 10 Device and Documentation Support

### 10.1 Documentation Support

#### 10.1.1 Related Documentation

For related documentation, see the following:

- Texas Instruments, [Sample and Hold Glitch Reduction for Precision Outputs Reference Design](#).
- Texas Instruments, [True Differential, 4 x 2 MUX, Analog Front End, Simultaneous-Sampling ADC Circuit](#).
- Texas Instruments, [Improve Stability Issues with Low CON Multiplexers](#).
- Texas Instruments, [Simplifying Design with 1.8V logic Muxes and Switches](#).
- Texas Instruments, [Eliminate Power Sequencing with Powered-off Protection Signal Switches](#).
- Texas Instruments, [System-Level Protection for High-Voltage Analog Multiplexers](#).
- Texas Instruments, [QFN/SON PCB Attachment](#).
- Texas Instruments, [Quad Flatpack No-Lead Logic Packages](#).

#### 10.2 Receiving Notification of Documentation Updates

To receive notification of documentation updates, navigate to the device product folder on [ti.com](#). Click on *Notifications* to register and receive a weekly digest of any product information that has changed. For change details, review the revision history included in any revised document.

#### 10.3 Support Resources

[TI E2E™ support forums](#) are an engineer's go-to source for fast, verified answers and design help — straight from the experts. Search existing answers or ask your own question to get the quick design help you need.

Linked content is provided "AS IS" by the respective contributors. They do not constitute TI specifications and do not necessarily reflect TI's views; see TI's [Terms of Use](#).

#### 10.4 Trademarks

TI E2E™ is a trademark of Texas Instruments.  
All trademarks are the property of their respective owners.

#### 10.5 Electrostatic Discharge Caution



This integrated circuit can be damaged by ESD. Texas Instruments recommends that all integrated circuits be handled with appropriate precautions. Failure to observe proper handling and installation procedures can cause damage.

ESD damage can range from subtle performance degradation to complete device failure. Precision integrated circuits may be more susceptible to damage because very small parametric changes could cause the device not to meet its published specifications.

#### 10.6 Glossary

[TI Glossary](#) This glossary lists and explains terms, acronyms, and definitions.

## 11 Revision History

NOTE: Page numbers for previous revisions may differ from page numbers in the current version.

<b>Changes from Revision B (August 2019) to Revision C (December 2023)</b>	<b>Page</b>
• Updated the numbering format for tables, figures, and cross-references throughout the document.....	<a href="#">1</a>
• Updated Is or Id (Continuous Current) values.....	<a href="#">4</a>
• Added Ipeak values to recommended operating conditions table.....	<a href="#">4</a>
<b>Changes from Revision A (June 2019) to Revision B (August 2019)</b>	<b>Page</b>
• Deleted the <i>Product Preview</i> note from: TMUX1113, TMUX1112 and the RSV package in the <i>Device Information</i> table.....	<a href="#">1</a>
• Deleted the <i>Product Preview</i> note from: TMUX1113, TMUX1112 in the <i>Device Comparison Table</i> table.....	<a href="#">2</a>
• Deleted the <i>Product Preview</i> note from: the RSV package in the <i>Pin Configuration and Functions</i> section.....	<a href="#">3</a>

- Added RSV (UQFN) thermal values to *Thermal Information* .....5
- 

**Changes from Revision \* (February 2019) to Revision A (June 2019) Page**

- Changed The document From: *Advanced Information* To: *Mixed Status*. ..... 1
- 

## 12 Mechanical, Packaging, and Orderable Information

The following pages include mechanical, packaging, and orderable information. This information is the most current data available for the designated devices. This data is subject to change without notice and revision of this document. For browser-based versions of this data sheet, refer to the left-hand navigation.



**PACKAGING INFORMATION**

Orderable Device	Status (1)	Package Type	Package Drawing	Pins	Package Qty	Eco Plan (2)	Lead finish/ Ball material (6)	MSL Peak Temp (3)	Op Temp (°C)	Device Marking (4/5)	Samples
TMUX1111PWR	ACTIVE	TSSOP	PW	16	2000	RoHS & Green	NIPDAU	Level-1-260C-UNLIM	-40 to 125	TM1111	<a href="#">Samples</a>
TMUX1111RSVR	ACTIVE	UQFN	RSV	16	3000	RoHS & Green	NIPDAU	Level-1-260C-UNLIM	-40 to 125	1FC	<a href="#">Samples</a>
TMUX1112PWR	ACTIVE	TSSOP	PW	16	2000	RoHS & Green	NIPDAU	Level-1-260C-UNLIM	-40 to 125	TM1112	<a href="#">Samples</a>
TMUX1112RSVR	ACTIVE	UQFN	RSV	16	3000	RoHS & Green	NIPDAU	Level-1-260C-UNLIM	-40 to 125	1FD	<a href="#">Samples</a>
TMUX1113PWR	ACTIVE	TSSOP	PW	16	2000	RoHS & Green	NIPDAU	Level-1-260C-UNLIM	-40 to 125	TM1113	<a href="#">Samples</a>
TMUX1113RSVR	ACTIVE	UQFN	RSV	16	3000	RoHS & Green	NIPDAU	Level-1-260C-UNLIM	-40 to 125	1FE	<a href="#">Samples</a>

(1) The marketing status values are defined as follows:

**ACTIVE:** Product device recommended for new designs.

**LIFEBUY:** TI has announced that the device will be discontinued, and a lifetime-buy period is in effect.

**NRND:** Not recommended for new designs. Device is in production to support existing customers, but TI does not recommend using this part in a new design.

**PREVIEW:** Device has been announced but is not in production. Samples may or may not be available.

**OBSOLETE:** TI has discontinued the production of the device.

(2) **RoHS:** TI defines "RoHS" to mean semiconductor products that are compliant with the current EU RoHS requirements for all 10 RoHS substances, including the requirement that RoHS substance do not exceed 0.1% by weight in homogeneous materials. Where designed to be soldered at high temperatures, "RoHS" products are suitable for use in specified lead-free processes. TI may reference these types of products as "Pb-Free".

**RoHS Exempt:** TI defines "RoHS Exempt" to mean products that contain lead but are compliant with EU RoHS pursuant to a specific EU RoHS exemption.

**Green:** TI defines "Green" to mean the content of Chlorine (Cl) and Bromine (Br) based flame retardants meet JS709B low halogen requirements of <=1000ppm threshold. Antimony trioxide based flame retardants must also meet the <=1000ppm threshold requirement.

(3) MSL, Peak Temp. - The Moisture Sensitivity Level rating according to the JEDEC industry standard classifications, and peak solder temperature.

(4) There may be additional marking, which relates to the logo, the lot trace code information, or the environmental category on the device.

(5) Multiple Device Markings will be inside parentheses. Only one Device Marking contained in parentheses and separated by a "-" will appear on a device. If a line is indented then it is a continuation of the previous line and the two combined represent the entire Device Marking for that device.

(6) Lead finish/Ball material - Orderable Devices may have multiple material finish options. Finish options are separated by a vertical ruled line. Lead finish/Ball material values may wrap to two lines if the finish value exceeds the maximum column width.

**Important Information and Disclaimer:** The information provided on this page represents TI's knowledge and belief as of the date that it is provided. TI bases its knowledge and belief on information provided by third parties, and makes no representation or warranty as to the accuracy of such information. Efforts are underway to better integrate information from third parties. TI has taken and continues to take reasonable steps to provide representative and accurate information but may not have conducted destructive testing or chemical analysis on incoming materials and chemicals. TI and TI suppliers consider certain information to be proprietary, and thus CAS numbers and other limited information may not be available for release.

In no event shall TI's liability arising out of such information exceed the total purchase price of the TI part(s) at issue in this document sold by TI to Customer on an annual basis.

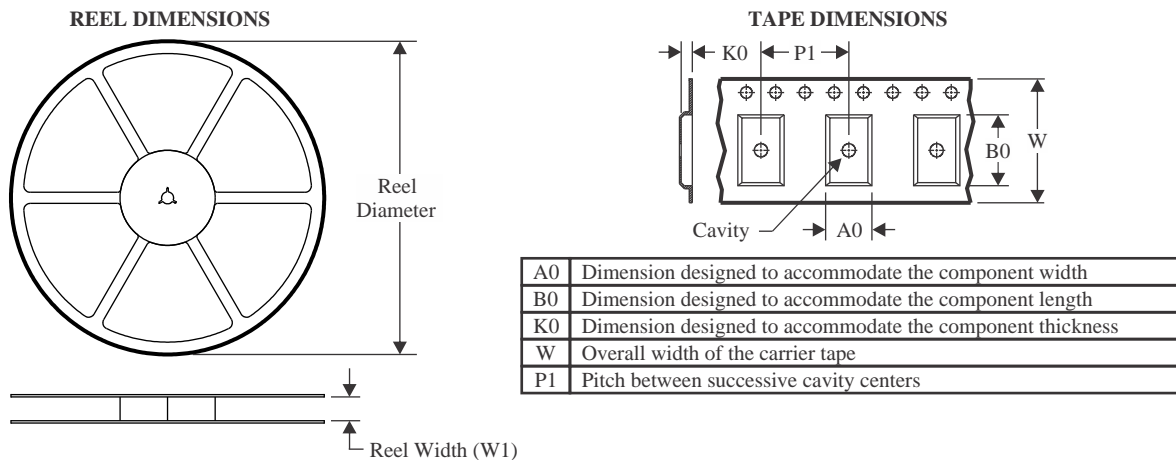
**TAPE AND REEL INFORMATION**

**QUADRANT ASSIGNMENTS FOR PIN 1 ORIENTATION IN TAPE**

\*All dimensions are nominal

Device	Package Type	Package Drawing	Pins	SPQ	Reel Diameter (mm)	Reel Width W1 (mm)	A0 (mm)	B0 (mm)	K0 (mm)	P1 (mm)	W (mm)	Pin1 Quadrant
TMUX1111PWR	TSSOP	PW	16	2000	330.0	12.4	6.9	5.6	1.6	8.0	12.0	Q1
TMUX1111RSVR	UQFN	RSV	16	3000	178.0	13.5	2.1	2.9	0.75	4.0	12.0	Q1
TMUX1112PWR	TSSOP	PW	16	2000	330.0	12.4	6.9	5.6	1.6	8.0	12.0	Q1
TMUX1112RSVR	UQFN	RSV	16	3000	178.0	13.5	2.1	2.9	0.75	4.0	12.0	Q1
TMUX1113PWR	TSSOP	PW	16	2000	330.0	12.4	6.9	5.6	1.6	8.0	12.0	Q1
TMUX1113RSVR	UQFN	RSV	16	3000	178.0	13.5	2.1	2.9	0.75	4.0	12.0	Q1

**TAPE AND REEL BOX DIMENSIONS**

\*All dimensions are nominal

Device	Package Type	Package Drawing	Pins	SPQ	Length (mm)	Width (mm)	Height (mm)
TMUX1111PWR	TSSOP	PW	16	2000	356.0	356.0	35.0
TMUX1111RSVR	UQFN	RSV	16	3000	189.0	185.0	36.0
TMUX1112PWR	TSSOP	PW	16	2000	356.0	356.0	35.0
TMUX1112RSVR	UQFN	RSV	16	3000	189.0	185.0	36.0
TMUX1113PWR	TSSOP	PW	16	2000	356.0	356.0	35.0
TMUX1113RSVR	UQFN	RSV	16	3000	189.0	185.0	36.0



4220204/A 02/2017

NOTES:

1. All linear dimensions are in millimeters. Any dimensions in parenthesis are for reference only. Dimensioning and tolerancing per ASME Y14.5M.
2. This drawing is subject to change without notice.
3. This dimension does not include mold flash, protrusions, or gate burrs. Mold flash, protrusions, or gate burrs shall not exceed 0.15 mm per side.
4. This dimension does not include interlead flash. Interlead flash shall not exceed 0.25 mm per side.
5. Reference JEDEC registration MO-153.

# EXAMPLE BOARD LAYOUT

PW0016A

TSSOP - 1.2 mm max height

SMALL OUTLINE PACKAGE



LAND PATTERN EXAMPLE  
EXPOSED METAL SHOWN  
SCALE: 10X



SOLDER MASK DETAILS

4220204/A 02/2017

NOTES: (continued)

- 6. Publication IPC-7351 may have alternate designs.
- 7. Solder mask tolerances between and around signal pads can vary based on board fabrication site.

# EXAMPLE STENCIL DESIGN

PW0016A

TSSOP - 1.2 mm max height

SMALL OUTLINE PACKAGE



SOLDER PASTE EXAMPLE  
BASED ON 0.125 mm THICK STENCIL  
SCALE: 10X

4220204/A 02/2017

NOTES: (continued)

8. Laser cutting apertures with trapezoidal walls and rounded corners may offer better paste release. IPC-7525 may have alternate design recommendations.
9. Board assembly site may have different recommendations for stencil design.

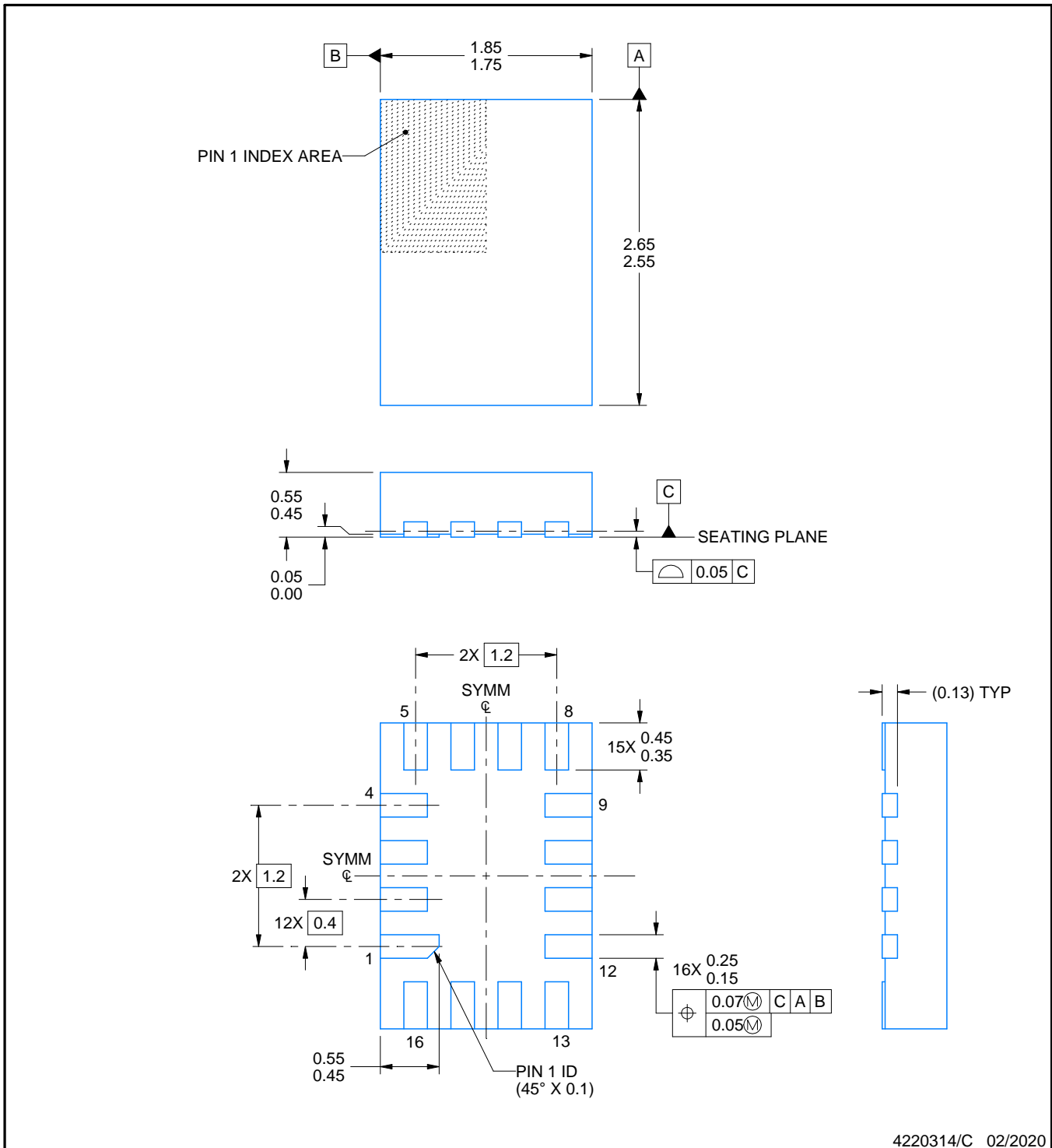
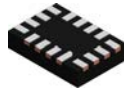

4220314/C 02/2020

NOTES:

1. All linear dimensions are in millimeters. Any dimensions in parenthesis are for reference only. Dimensioning and tolerancing per ASME Y14.5M.
2. This drawing is subject to change without notice.



# EXAMPLE BOARD LAYOUT

RSV0016A

UQFN - 0.55 mm max height

ULTRA THIN QUAD FLATPACK - NO LEAD

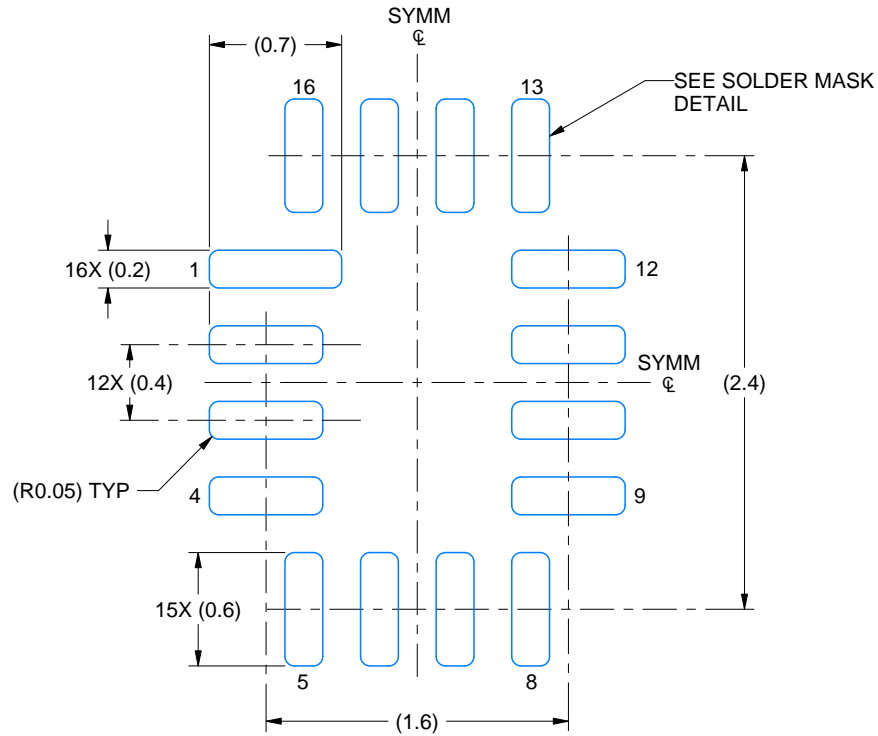

LAND PATTERN EXAMPLE  
EXPOSED METAL SHOWN  
SCALE: 25X

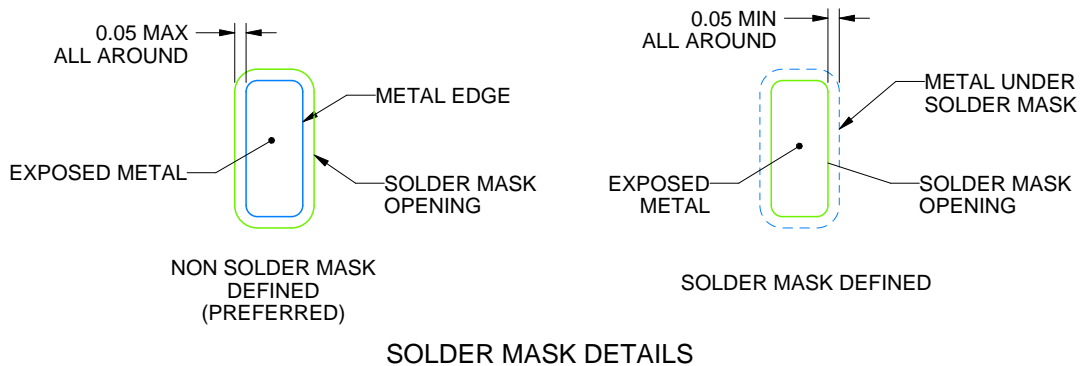

4220314/C 02/2020

NOTES: (continued)

3. For more information, see Texas Instruments literature number SLUA271 ([www.ti.com/lit/slua271](http://www.ti.com/lit/slua271)).

# EXAMPLE STENCIL DESIGN

RSV0016A

UQFN - 0.55 mm max height

ULTRA THIN QUAD FLATPACK - NO LEAD

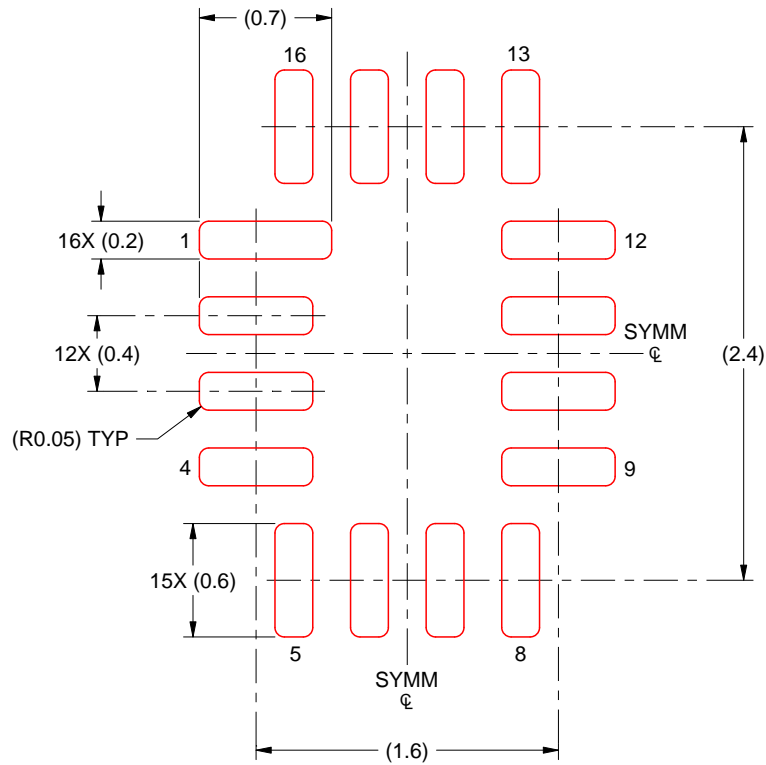

SOLDER PASTE EXAMPLE  
BASED ON 0.125 MM THICK STENCIL  
SCALE: 25X

4220314/C 02/2020

NOTES: (continued)

4. Laser cutting apertures with trapezoidal walls and rounded corners may offer better paste release. IPC-7525 may have alternate design recommendations.

## IMPORTANT NOTICE AND DISCLAIMER

TI PROVIDES TECHNICAL AND RELIABILITY DATA (INCLUDING DATA SHEETS), DESIGN RESOURCES (INCLUDING REFERENCE DESIGNS), APPLICATION OR OTHER DESIGN ADVICE, WEB TOOLS, SAFETY INFORMATION, AND OTHER RESOURCES "AS IS" AND WITH ALL FAULTS, AND DISCLAIMS ALL WARRANTIES, EXPRESS AND IMPLIED, INCLUDING WITHOUT LIMITATION ANY IMPLIED WARRANTIES OF MERCHANTABILITY, FITNESS FOR A PARTICULAR PURPOSE OR NON-INFRINGEMENT OF THIRD PARTY INTELLECTUAL PROPERTY RIGHTS.

These resources are intended for skilled developers designing with TI products. You are solely responsible for (1) selecting the appropriate TI products for your application, (2) designing, validating and testing your application, and (3) ensuring your application meets applicable standards, and any other safety, security, regulatory or other requirements.

These resources are subject to change without notice. TI grants you permission to use these resources only for development of an application that uses the TI products described in the resource. Other reproduction and display of these resources is prohibited. No license is granted to any other TI intellectual property right or to any third party intellectual property right. TI disclaims responsibility for, and you will fully indemnify TI and its representatives against, any claims, damages, costs, losses, and liabilities arising out of your use of these resources.

TI's products are provided subject to [TI's Terms of Sale](#) or other applicable terms available either on [ti.com](https://www.ti.com) or provided in conjunction with such TI products. TI's provision of these resources does not expand or otherwise alter TI's applicable warranties or warranty disclaimers for TI products.

TI objects to and rejects any additional or different terms you may have proposed.

Mailing Address: Texas Instruments, Post Office Box 655303, Dallas, Texas 75265  
Copyright © 2024, Texas Instruments Incorporated