

TPS2376-H IEEE802.3af, 600-mA Capable, PD Controller

1 Features

- Adjustable Turn-on Thresholds
- Permits High-power 26 W Designs
- Integrated 0.58- Ω , 100-V, Low-Side Switch
- 15-kV System Level ESD Capable
- Industrial Temperature Range: -40°C to 85°C
- 8-Pin PowerPad™ SOIC Package

2 Applications

- VoIP Video and Speaker Phones
- WiMAX Access Points
- Security Cameras
- RFID Readers

3 Description

The 8-pin integrated circuit contains all of the features needed to develop a high power IEEE 802.3af style powered device (PD). The TPS2376-H offers a higher current limit and increased thermal dissipation capability over the TPS237X family of devices. The TPS2376-H implements a fully compliant PoE interface while permitting non-standard implementations that draw more power. A 26 W PD may be constructed when working from a 52-V minimum PSE over 100 m of CAT-5 cable. The TPS2376-H features a 100-V rating, 600-mA capability, adjustable inrush limiting, fault protection with auto-retry, and true open-drain power-good functionality.

Device Information⁽¹⁾

PART NUMBER	PACKAGE	BODY SIZE (NOM)
TPS2376-H	SOIC (8)	4.89 mm x 3.90 mm

(1) For all available packages, see the orderable addendum at the end of the data sheet.

Typical Application Circuit

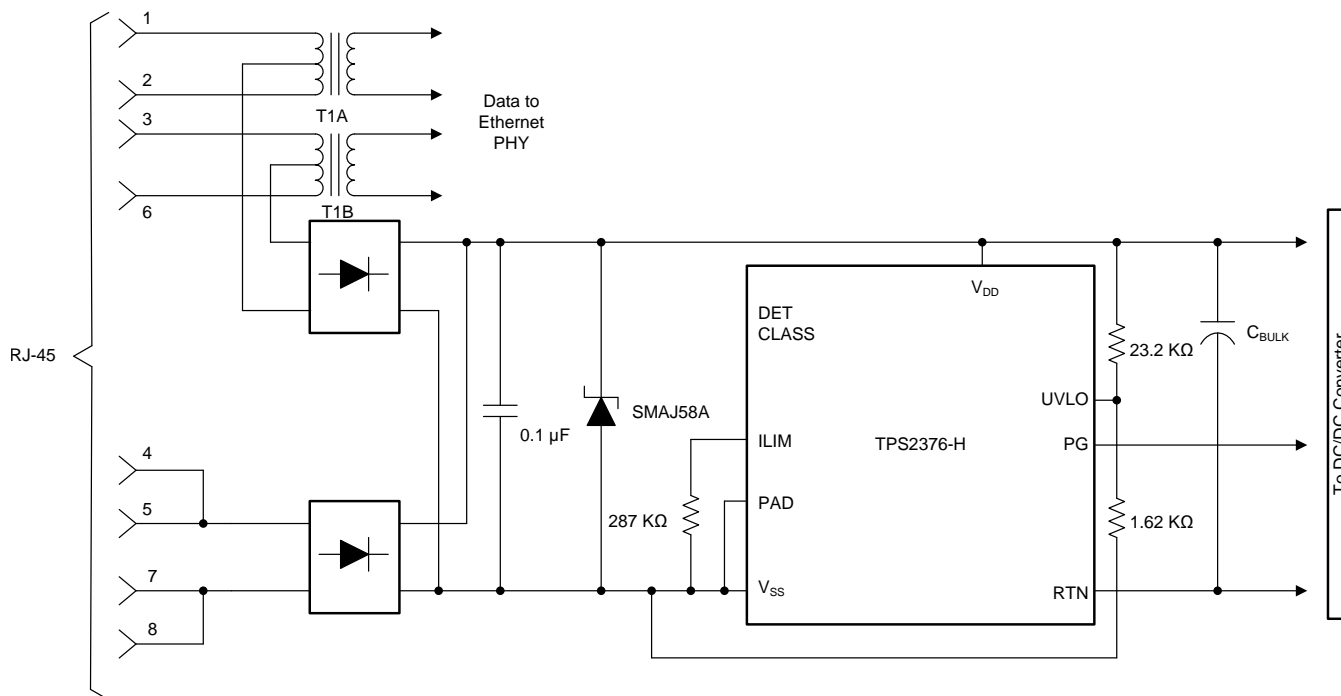

Table of Contents

1 Features 1 2 Applications 1 3 Description 1 4 Revision History 2 5 Device Comparison Table 3 6 Pin Configuration and Functions 3 7 Specifications 4 7.1 Absolute Maximum Ratings 4 7.2 ESD Ratings 4 7.3 ESD Ratings IEC 4 7.4 Recommended Operating Conditions 4 7.5 Thermal Information 5 7.6 Electrical Characteristics..... 5 7.7 Typical Characteristics 7 8 Detailed Description 9 8.1 Overview 9 8.2 Functional Block Diagram 10 8.3 Feature Description..... 10 9 Application and Implementation 12	9.1 Application Information..... 12 9.2 Typical Application 14 10 Power Supply Recommendations 15 10.1 Maintain Power Signature 15 10.2 DC/DC Converter Startup 15 10.3 Auxiliary Power Source ORing..... 16 11 Layout 17 11.1 Layout Guidelines 17 11.2 Layout Example 18 11.3 Thermal Protection..... 18 11.4 ESD..... 18 12 Device and Documentation Support 19 12.1 Documentation Support 19 12.2 Receiving Notification of Documentation Updates 19 12.3 Community Resources..... 19 12.4 Trademarks 19 12.5 Electrostatic Discharge Caution..... 19 12.6 Glossary 19 13 Mechanical, Packaging, and Orderable Information 19
--	---

4 Revision History

NOTE: Page numbers for previous revisions may differ from page numbers in the current version.

Changes from Revision A (September 2006) to Revision B	Page
• Changed title from IEEE 802.3af PoE High Power PD Controller to IEEE 802.3af, 600-mA Capable, PD Controller 1	1
• Added <i>Device Information</i> table, <i>ESD Ratings</i> table, <i>Thermal Information</i> table, <i>Feature Description</i> section, <i>Application and Implementation</i> section, <i>Power Supply Recommendations</i> section, <i>Device and Documentation Support</i> section, <i>Mechanical, Packaging, and Orderable Information</i> section 1	1
• Deleted the <i>Product Selector</i> table see the <i>Device Comparison</i> table 3	3
• Deleted <i>Dissipation Rating</i> Table see <i>Thermal Information</i> table 5	5
• Deleted <i>Available Options</i> table see <i>Packaging Information</i> at the end of the data sheet 19	19

5 Device Comparison Table

Device	UVLO	Protection	Package ⁽¹⁾	Rated Current
TPS2376-H	Adjustable	Auto-Retry	DDA	600 mA
TPS2375-1	802.3af	Auto-Retry	PW	400 mA
TPS2377-1	Legacy	Auto-Retry	D	400 mA
TPS2375	802.3af	Latch	PW, D	400 mA
TPS2376	Adjustable	Latch	PW, D	400 mA
TPS2377	Legacy	Latch	PW, D	400 mA

(1) Packages codes as follows: D = S0, DDA = SO PowerPad, PW = TSSOP

6 Pin Configuration and Functions

**DDA PACKAGE
8-Pin SOIC
Top View**

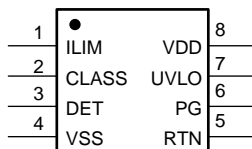

Pin Functions

PIN		I/O	DESCRIPTION
NAME	NO. '76-H		
CLASS	2	O	Connect a resistor from CLASS to VSS to set the classification of the powered device (PD). The IEEE classification levels and corresponding resistor values are shown in Table 1 .
DET	3	O	Connect a 24.9-kΩ detection resistor from DET to VDD.
ILIM	1	O	Connect a resistor from ILIM to VSS to set the start-up inrush current limit. The equation for calculating the resistor is shown in the detailed pin description section for ILIM.
PG	6	O	Open-drain, power-good output, active high, referenced to RTN.
RTN	5	O	Switched output side return line used as the low-side reference for the TPS2376-H load.
UVLO	7	I	UVLO comparator input that controls pass-device turn-on and off. Connect UVLO to a resistor divider from VDD to VSS.
VDD	8	I	Positive line from the rectified PSE provided input.
VSS	4	I	Return line on the source side of the TPS2376-H from the PSE.
PowerPad™	—	I	The PowerPad must be connected to VSS. The VSS copper on the circuit board must be a large fill area to assist in heat dissipation.

7 Specifications

7.1 Absolute Maximum Ratings

over operating free-air temperature range (unless otherwise noted) ⁽¹⁾, voltages are referenced to $V_{(VSS)}$

		MIN	MAX	UNIT
Voltage	VDD, RTN ⁽²⁾ , DET, PG	-0.3	100	V
	ILIM, UVLO	-0.3	10	
	CLASS	-0.3	12	
Current, sinking	RTN ⁽³⁾	Internally Limited		mA
	PG	0	5	
	DET	0	1	
Current, sourcing	CLASS	0	50	
	ILIM	0	1	
T _J	Maximum junction temperature range	Internally Limited		
	Lead temperature 1,6 mm (1/16 inch) from case for 10 seconds		260	°C
T _{stg}	Storage temperature	-65	150	

(1) Stresses beyond those listed under “absolute maximum ratings” may cause permanent damage to the device. These are stress ratings only, and functional operation of the device at these or any other conditions beyond those indicated under “recommended operating conditions” is not implied. Exposure to absolute–maximum–rated conditions for extended periods may affect device reliability.

(2) $I_{(RTN)} = 0$

(3) SOA limited to $V_{(RTN)} = 80$ V and $I_{(RTN)} = 900$ mA.

7.2 ESD Ratings

		VALUE	UNIT
V _(ESD)	Electrostatic discharge Human-body model (HBM), per ANSI/ESDA/JEDEC JS-001 ⁽¹⁾	±2	kV

(1) JEDEC document JEP155 states that 500-V HBM allows safe manufacturing with a standard ESD control process.

7.3 ESD Ratings IEC

		VALUE	UNIT	
V _(ESD)	Electrostatic discharge	IEC 61000-4-2 contact discharge at RJ-45 ⁽¹⁾	±8	kV
		IEC 61000-4-2 air-gap discharge at RJ-45 ⁽¹⁾	±15	

(1) Surges applied to RJ-45 of the *Typical Application Circuit* between pins of RJ-45, and between pins and output voltage rails per EN61000-4-2, 1999.

7.4 Recommended Operating Conditions

		MIN	MAX	UNIT	
Input voltage range	VDD, PG, RTN	0	57	V	
Operating current range (sinking)	RTN	0	600	mA	
Classification resistor ⁽¹⁾	CLASS	255	4420	Ω	
R _(ILIM)	Inrush limit program resistor ⁽¹⁾	125	1000	kΩ	
Sinking current	PG	0	2	mA	
T _J	Operating junction temperature	$I_{RTN} \leq 400$ mA	-40	125	°C
		400 mA < $I_{RTN} \leq 600$ mA ⁽²⁾	-40	105	
T _A	Operating free-air temperature	-40	85	°C	

(1) Voltage should not be externally applied to CLASS and ILIM.

(2) Temperature limitation is for 10 year life-expectancy at this temperature. Short-term operation to 125 °C is permissible.

7.5 Thermal Information

THERMAL METRIC ⁽¹⁾		TPS2376-H		UNIT
		DDA (SOIC)		
		8 PINS		
R _{θJA}	Junction-to-ambient thermal resistance	Modified High-K ⁽²⁾	58.6	°C/W
		Modified Low-K ⁽²⁾	50	
		Best ⁽²⁾	45	

(1) For more information about traditional and new thermal metrics, see the [Semiconductor and IC Package Thermal Metrics](#) application report.

(2) Tested per JEDEC JESD51, natural convection. The definitions of high-k and low-k are per JESD 51-7 and JESD 51-3. Modified low-k (2 signal - no plane, 3 in. by 3 in. board, 0.062 in. thick, 1 oz. copper) test board with the pad soldered, and an additional 0.12 in.2 of top-side copper added to the pad. Modified high-k is a (2 signal - 2 plane) test board with the pad soldered. The best case thermal resistance is obtained using the recommendations per SLMA002 (2 signal - 2 plane with the pad connected to the plane).

7.6 Electrical Characteristics

V_(VDD) = 48 V, R_(DET) = 24.9 kΩ, R_(CLASS) = 255 Ω, R_(ILIM) = 287 kΩ, and -40°C ≤ T_J ≤ 125°C, unless otherwise noted. Positive currents are into pins. Typical values are at 25°C. All voltages are with respect to VSS unless otherwise noted.

PARAMETER		TEST CONDITIONS	MIN	TYP	MAX	UNIT	
DETECTION							
Offset current		DET open, V _(VDD) = V _(RTN) = 1.9 V, measure I _(VDD) + I _(RTN)		0.3	3	μA	
Sleep current		DET open, V _(VDD) = V _(RTN) = 10.1 V, measure I _(VDD) + I _(RTN)		4	12	μA	
DET leakage current		V _(DET) = V _(VDD) = 57 V, measure I _(DET)		0.1	5	μA	
Detection current		V _(RTN) = V _(VDD) , R _(DET) = 24.9 kΩ, measure I _(VDD) + I _(RTN) + I _(DET)	V _(VDD) = 1.4 V	53.7	56	58.3	μA
			V _(VDD) = 10.1 V	395	410	417	μA
CLASSIFICATION							
I _(CLASS)	Classification current ⁽¹⁾	Measure I _(VDD) + I _(RTN) , 13 V ≤ V _(VDD) ≤ 21 V, V _(VDD) = V _(RTN)				mA	
		R _(CLASS) = 4420 Ω	2.2	2.4	2.8		
		R _(CLASS) = 953 Ω	10.3	10.6	11.3		
		R _(CLASS) = 549 Ω	17.7	18.3	19.5		
		R _(CLASS) = 357 Ω	27.1	28	29.5		
V _(CL_ON)	Classification lower threshold	Regulator turns on, V _(VDD) rising	10.2	11.3	13	V	
		Hysteresis	1.6	1.8	1.95		
V _(CU_OFF)	Classification upper threshold	Regulator turns off, V _(VDD) rising	21	21.9	23	V	
V _(CU_H)		Hysteresis	0.5	0.78	1	V	
I _{lkg}	Leakage current	V _(CLASS) = 0 V, V _(VDD) = 57 V			1	μA	
PASS DEVICE							
r _{DS(on)}	On resistance			0.58	1	Ω	
	Leakage current	V _(VDD) = V _(RTN) = 30 V			15	μA	
	Current limit	V _(RTN) = 1 V	625	765	900	mA	
I _(LIM)	Inrush limit	V _(RTN) = 2 V, R _(ILIM) = 178 kΩ	160	224	296	mA	
	Inrush current termination ⁽²⁾	V _(RTN) falling, R _(ILIM) = 287 kΩ, inrush state → normal operation	85	91	100	%	
	Leakage current, ILIM	V _(VDD) = 15 V, V _(UVLO) = 0 V			1	μA	

(1) Classification is tested with exact resistor values. A 1% tolerance classification resistor ensures compliance with IEEE 802.3af limits.

(2) This parameter specifies the RTN current value, as a percentage of the steady state inrush current, below which it must fall to make PG assert (open-drain).

Electrical Characteristics (continued)

$V_{(VDD)} = 48\text{ V}$, $R_{(DET)} = 24.9\text{ k}\Omega$, $R_{(CLASS)} = 255\ \Omega$, $R_{(ILIM)} = 287\text{ k}\Omega$, and $-40^\circ\text{C} \leq T_J \leq 125^\circ\text{C}$, unless otherwise noted. Positive currents are into pins. Typical values are at 25°C . All voltages are with respect to V_{SS} unless otherwise noted.

PARAMETER	TEST CONDITIONS	MIN	TYP	MAX	UNIT	
PG						
Voltage threshold rising ⁽³⁾	$V_{(RTN)}$ rising	9.5	10	10.5	V	
PG deglitch	Delay rising and falling PG	75	150	225	μs	
Output low voltage	$I_{(PG)} = 2\text{ mA}$, $V_{(RTN)} = 34\text{ V}$, $V_{(VDD)} = 38\text{ V}$, $V_{(RTN)}$ falling		0.12	0.4	V	
	$I_{(PG)} = 2\text{ mA}$, $V_{(RTN)} = 0\text{ V}$, $V_{(VDD)} = 25\text{ V}$		0.12	0.4	V	
Leakage current	$V_{(PG)} = 57\text{ V}$, $V_{(RTN)} = 0\text{ V}$		0.1	1	μA	
UVLO						
$V_{(UVLO_R)}$	Voltage at UVLO - TPS2376-H	$V_{(UVLO)}$ rising	2.43	2.49	2.57	V
$V_{(UVLO_F)}$		$V_{(UVLO)}$ falling	1.87	1.93	1.98	
		Hysteresis	0.53	0.56	0.58	
THERMAL SHUTDOWN						
Shutdown temperature	Temperature rising	135			$^\circ\text{C}$	
Hysteresis			20		$^\circ\text{C}$	
BIAS CURRENT						
Operating current	$I_{(VDD)}$		240	450	μA	

(3) Start with $V_{(RTN)} = 0\text{ V}$, then increase $V_{(RTN)}$ until PG switches. Measure before thermal shutdown occurs.

7.7 Typical Characteristics

Graphs over temperature are interpolations between the marked data points.

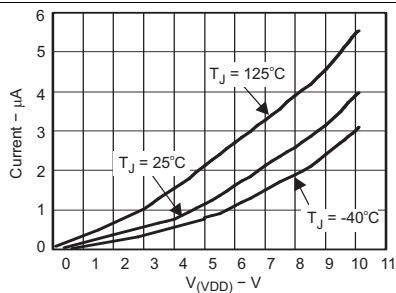

Figure 1. $I_{(VDD)} + I_{(RTN)}$

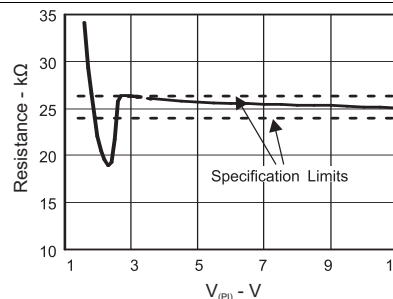

Figure 2. PD Detection Resistance vs $V_{(PI)}$

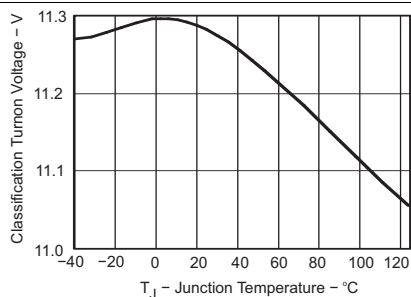

Figure 3. Classification Turn On Voltage vs Temperature

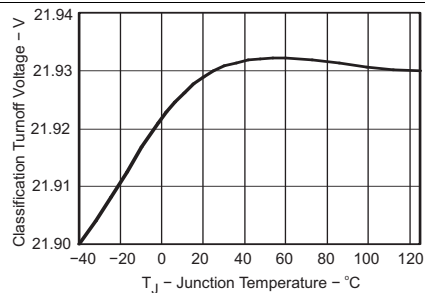

Figure 4. Classification Turn Off Voltage vs Temperature

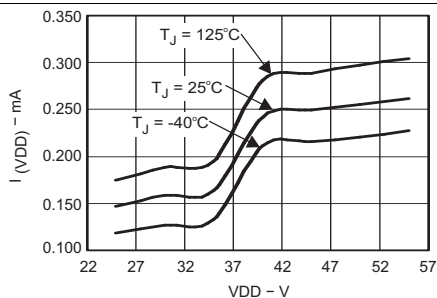

Figure 5. $I_{(VDD)}$ vs VDD

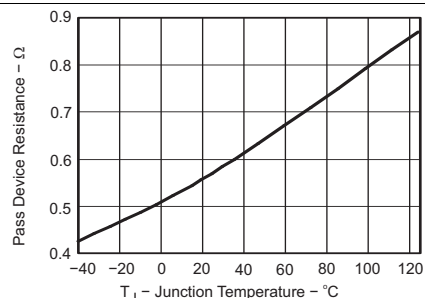

Figure 6. Pass Device Resistance vs Temperature

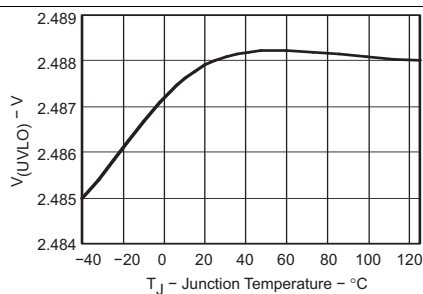

Figure 7. UVLO Rising vs Temperature

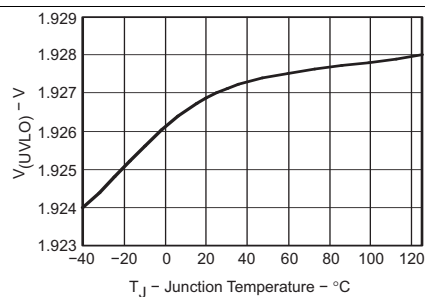

Figure 8. UVLO Falling vs Temperature

Typical Characteristics (continued)

Graphs over temperature are interpolations between the marked data points.

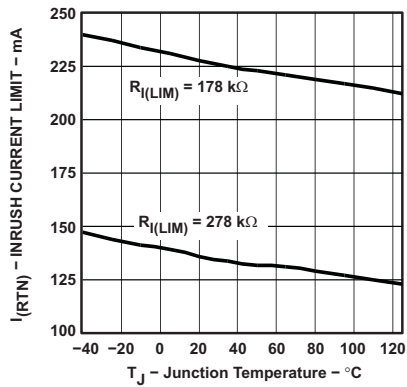

Figure 9. Inrush Current vs Temperature

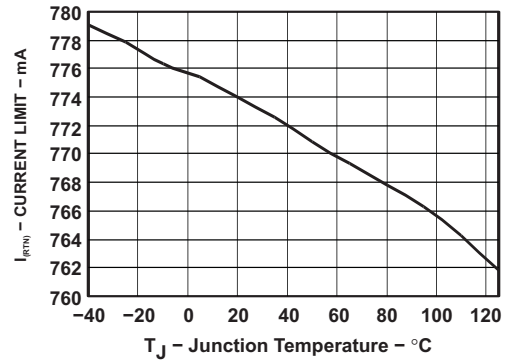

Figure 10. Current Limit vs Temperature

8 Detailed Description

8.1 Overview

The following descriptions refer to the schematic of [Typical Application Circuit](#) and the [Functional Block Diagram](#).

ILIM : A resistor from this pin to VSS sets the inrush current limit per [Equation 1](#):

$$I_{(LIM)} = \frac{40000}{R_{(ILIM)}} \quad (1)$$

where ILIM is the desired inrush current value, in Amperes, and $R_{(ILIM)}$ is the value of the programming resistor from ILIM to VSS, in ohms. The practical limits on $R_{(ILIM)}$ are 125 kΩ to 1 MΩ. A value of 287 kΩ is recommended for compatibility with legacy power sourcing equipment (PSE).

Inrush current limiting prevents current drawn by the bulk capacitor from causing the line voltage to sag below the lower UVLO threshold. Adjustable inrush current limiting allows the use of arbitrarily large capacitors and also accommodates legacy systems that require low inrush currents.

The ILIM pin must not be left open or shorted to VSS.

CLASS: Classification is implemented by means of an external resistor, $R_{(CLASS)}$, connected between CLASS and VSS. The controller draws current from the input line through $R_{(CLASS)}$ when the input voltage lies between 13 V and 21 V. The classification currents specified in the electrical characteristics table include the bias current flowing into VDD and any RTN leakage current.

A high power system will not meet the standard power CLASS ranges defined in IEEE 802.3af, which are shown for reference in [Table 1](#). An end-to-end high power system may either redefine the CLASS power, or dispense with CLASS entirely.

The CLASS pin must not be shorted to ground.

Table 1. Classification - IEEE 802.3af Values

CLASS	PD POWER (W)	$R_{(CLASS)}$ (Ω)	802.3af LIMITS (mA)	NOTE
0	0.44 – 12.95	4420 ±1%	0 - 4	Default class
1	0.44 – 3.84	953 ±1%	9 - 12	
2	3.84 – 6.49	549 ±1%	17 - 20	
3	6.49 – 12.95	357 ±1%	26 - 30	
4	-	255 ±1%	36 - 44	Reserved for future use

DET: $R_{(DET)}$ should be connected between VDD and the DET pin when it is used. $R_{(DET)}$ is connected across the input line when $V_{(VDD)}$ lies between 1.4 V and 11.3 V, and is disconnected when the line voltage exceeds this range to conserve power.

The parallel combination of $R_{(DET)}$ and the UVLO program resistors must equal 24.9 kΩ, ±1%. Minimizing $R_{(DET)}$, and maximizing the UVLO program resistors, improves efficiency during normal operation. Conversely, $R_{(DET)}$ may be eliminated with the UVLO divider providing the 24.9 kΩ signature to reduce component count.

VSS: This is the input supply negative rail that serves as a local ground. The PowerPad must be connected to this pin.

RTN: This pin provides the switched negative power rail used by the downstream circuits. The operational and inrush current limit control current into the pin. The PG circuit monitors the RTN voltage and also uses it as the return for the PG pin pulldown transistor. The internal MOSFET body diode clamps VSS to RTN when voltage is present between VDD and RTN and the Power-over-Ethernet (PoE) input is not present.

PG: This pin goes to a high resistance state when the internal MOSFET that feeds the RTN pin is enabled, and the device is not in inrush current limiting. In all other states except detection, the PG output is pulled to RTN by the internal open-drain transistor. Performance is ensured with at least 4 V between VDD and RTN.

PG is an open-drain output, which may require a pullup resistor or other interface to the dc/dc converter. PG may be left open if not used.

UVLO: The UVLO pin is used with an external resistor divider between VDD and VSS to set the upper and lower UVLO thresholds. The TPS2376-H enables the output when $V_{(UVLO)}$ exceeds the upper UVLO threshold, and turns it off when the input falls below the lower threshold.

The UVLO divider resistance may be used alone to provide the 24.9 kΩ detection signature, or be used in conjunction with $R_{(DET)}$. Eliminating $R_{(DET)}$ reduces the component count at the cost of lower operating efficiency. The [Typical Application Circuit](#) demonstrates the elimination of $R_{(DET)}$.

VDD: This is the positive input supply that is also common to downstream load circuits. This pin provides operating power and allows the controller to monitor the line voltage to determine the mode of operation.

8.2 Functional Block Diagram

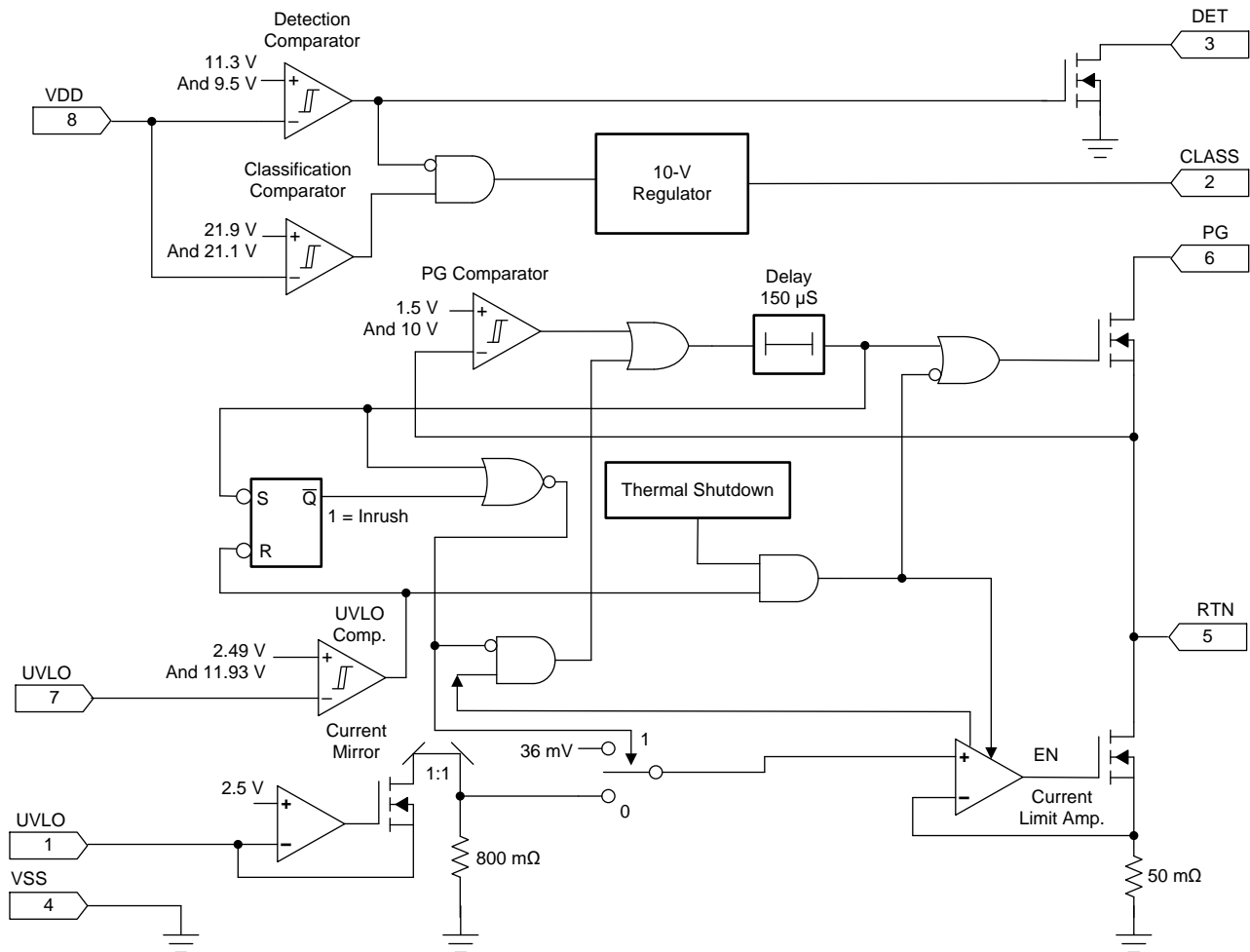

8.3 Feature Description

8.3.1 Undervoltage Lockout (UVLO)

The TPS2376-H incorporates an undervoltage lockout (UVLO) circuit that monitors line voltage to determine when to apply power to the downstream load and allow the PD to power up. The IEEE 802.3af specification dictates a maximum PD turn on voltage of 42 V and a minimum turn-off voltage of 30 V shown in [Figure 12](#). The UVLO pin provides the flexibility to adjust the turn on and turn off to the IEEE 802.3af limits, or a custom set. Design the turn-on for 39.5 V if a design which uses the IEEE 802.3af limits is desired.

Feature Description (continued)

8.3.2 Programmable Inrush Current Limit and Fixed Operational Current Limit

Inrush limiting has several benefits. First, it maintains the cable voltage above the UVLO turn-off threshold as the bulk capacitor charges. Second, it keeps the PSE from going into current limit. This reduces stress on the PSE and allows an arbitrarily large bulk capacitor to be charged. Third, the inrush limit is used as the foldback current during a hard overload.

The TPS2376-H operational current limit protects the internal power switch from sudden output faults and current surges. The minimum operational current limit level of 625 mA lies above the minimum TPS23841 output current limit of 600 mA. This current limit enables the PD to draw the maximum available power.

The TPS2376-H incorporates a state machine that controls the inrush and operational current limit states. When $V_{(VDD)}$ is below the lower UVLO threshold, the current limit state machine is reset. In this condition, the RTN pin is high impedance, and floats to $V_{(VDD)}$ once the output capacitor is discharged. When $V_{(VDD)}$ rises above the UVLO turn on threshold, the TPS2376-H enables the internal power MOSFET with the current limit set to the inrush value programmed by $R_{(ILIM)}$. The load capacitor charges and the RTN pin voltage falls from $V_{(VDD)}$ to nearly $V_{(VSS)}$. Once the inrush current falls about 10% below the programmed limit for 150- μ s, the current limit switches to the 765-mA operational level and PG goes open-drain. The internal power MOSFET is disabled if the input voltage drops below the lower UVLO threshold and the state machine is reset.

An output overload, or increasing input voltage step, may cause the operational current limit to become active. The MOSFET voltage will then start to rise, causing high power dissipation. Current-limit foldback controls this MOSFET power dissipation to a manageable level. Foldback is achieved by switching the current limit state machine from the operational level to inrush when the MOSFET voltage exceeds 10 V for 150- μ s. An additional layer of protection is provided by thermal shutdown if the overload persists long enough.

Practical values of $R_{(ILIM)}$ lie between 125 k Ω and 1 M Ω ; however, selecting lower inrush current values reduces peak stresses under output-short circuit conditions. An inrush level of 140 mA, set by an $R_{(ILIM)}$ of 287 k Ω , is recommended for most applications.

8.3.3 Power Good

The TPS2376-H includes a power-good (PG) output for use as a dc/dc converter enable once the load capacitor is fully charged. The PG pin is the safest way to ensure that there are no undesired interactions between the inrush limit, the converter startup characteristic, and the size of the bulk capacitor.

The PG output is pulled to RTN whenever the MOSFET is disabled, is in inrush current limiting, or the $V_{(RTN)}$ rises above 10 V. The PG pin goes to an open-drain state approximately 150 μ s after the inrush current falls 10% below the regulated value. PG pull down current is only specified for $V_{(VDD-RTN)}$ greater than 4 V, below which the dc/dc converter should not be able to operate. The PG interface to the downstream dc/dc converter is simplified by referencing it to RTN.

The PG pin can be left open if it is not used.

9 Application and Implementation

NOTE

Information in the following applications sections is not part of the TI component specification, and TI does not warrant its accuracy or completeness. TI's customers are responsible for determining suitability of components for their purposes. Customers should validate and test their design implementation to confirm system functionality.

9.1 Application Information

The IEEE 802.3af specification defines a process for safely providing power over an ethernet cable when a capable device is connected, and then removing power if it is disconnected. The process proceeds through three operational states: detection, classification, and operation. An unterminated cable is not powered. The PSE periodically probes the cable with low voltage, looking for a 25 k Ω signature; this is referred to as detection. The low power levels used during detection are unlikely to cause damage to devices not designed for PoE. If a valid powered device (PD) signature is present during detection, then the PSE may optionally inquire about the amount of power the PD requires; this is referred to as classification. The PD may return a default full-power signature, or one of four other defined choices. In a high-power system, class may not be required, or the levels may be redefined to suit that particular system. The PSE may use the class power to determine if it has adequate power to operate this device, and later to determine if a device is using more power than it requested. At this point in the process, the PSE may choose to power the PD. The PSE output is protected against shorts and overloads when the PD is powered. The maintain power signature (MPS) is presented by the powered PD to assure the PSE that it is present. The MPS is either a minimum dc current, a maximum ac impedance, or both. When the MPS disappears, the PSE removes power and returns to its initial state. [Figure 11](#) shows the operational states as a function of PD input voltage range as defined in IEEE 802.3af.

The PD input is typically an RJ-45 (8-pin) connector, referred to as the power interface (PI). PD input requirements differ from PSE output requirements to account for voltage drops in the cable. The IEEE 802.3af specification uses a cable resistance of 20 Ω to derive the voltage limits at the PD from the PSE output requirements. While the 20 Ω specification covers telecom type wiring, CAT-5 infrastructure will meet a 12.5 Ω limit. Specifying the high-power system to operate over CAT-5 cable allows significantly more power to be delivered.

A high-power nonstandard system need not support all combinations of voltage delivery polarities and pair sets. The IEEE 802.3af PSE allows voltage of either polarity between the RX and TX pairs, or between the two spare pairs. An input diode or bridge is recommended to provide reverse input polarity protection. The bridge maintains compatibility with auto-MDIX systems that have reverse RX-TX pair assignments. The voltage drops associated with the input diode(s) cause a difference between the limits at the PI and the TPS2376-H specifications.

Two-pair power delivery is the simplest to implement, and is preferred if adequate power can be achieved. Application report SLVA225 presents a number of considerations for a high power PoE end-to-end system. Power delivery on all four pairs is significantly more complex, and is only recommended when two pair systems do not suffice. Considerations for high power systems are presented in Application Report [SLVA225](#).

The following discussion is intended as an aid in understanding the operation of the TPS2376-H, but not as a substitute for the IEEE 802.3af standard. Standards change and should always be referenced when making design decisions.

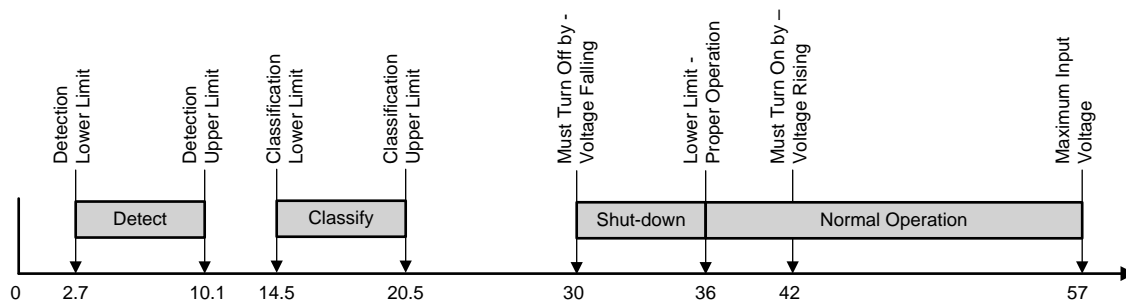

Figure 11. IEEE 802.3 PD Voltage Limits

Application Information (continued)

9.1.1 Internal Thresholds

In order to implement the defined PoE functions shown in Figure 11, the TPS2376-H has a number of internal comparators with hysteresis for stable switching between the various states. Figure 12 relates the parameters in the *Electrical Characteristics* section to the PoE states. The mode labeled *idle* between classification and PD powered implies that the DET, CLASS, PG, and RTN pins are all high impedance.

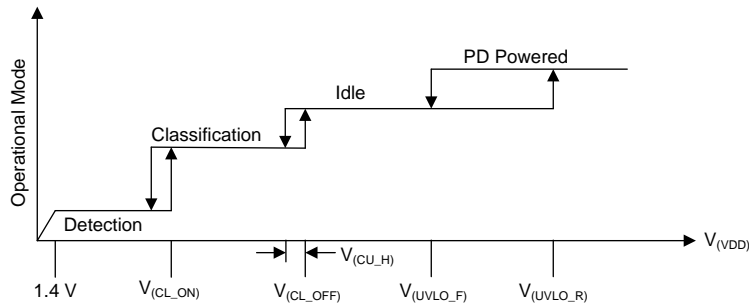

Figure 12. Threshold Voltages

9.1.2 Detection

The 25 k Ω PD signature is measured by applying two voltages between 2.7 V to 10.1 V, that are at least 1 V apart, to the PD's PI and measuring the current. The resistance is calculated as a $\Delta V/\Delta I$, with an acceptable range of 23.75 k Ω to 26.25 k Ω .

The TPS2376-H is in detection mode whenever the supply voltage is below the lower classification threshold. The TPS2376-H draws a minimum of bias power in this condition, while PG and RTN are high impedance and the circuits associated with ILIM and CLASS are disabled. The DET pin is pulled to VSS during detection. Current flowing through $R_{(DET)}$ to VSS shown in Figure 13 produces the detection signature.

9.1.3 Classification

The classification process applies a voltage between 14.5 V and 20.5 V, for a maximum of 75 ms, to the input of the PD, which in turn draws a fixed current set by $R_{(CLASS)}$. An 802.3af PSE measures the PD current to determine which of the five available classes shown in Table 1 that the PD is signaling. The total current drawn from the PSE during classification is the sum of bias currents and current through $R_{(CLASS)}$. The TPS2376-H disconnects $R_{(CLASS)}$ at voltages above the classification range to avoid excessive power dissipation see Figure 11 and Figure 12.

A high power end-to-end system may choose to not implement classification, or redefine the power associated with each class. Low-voltage systems, for example 24 V, may not be able to use CLASS because the operational voltage may lie within the classification voltage range. This would cause the TPS2376-H classification circuits to dissipate power continuously.

The power rating of the class resistor should be chosen so that it is not overstressed for the required 75-ms classification period, during which 10 V is applied. A higher wattage resistor might be required to withstand testing over longer time periods.

9.2 Typical Application

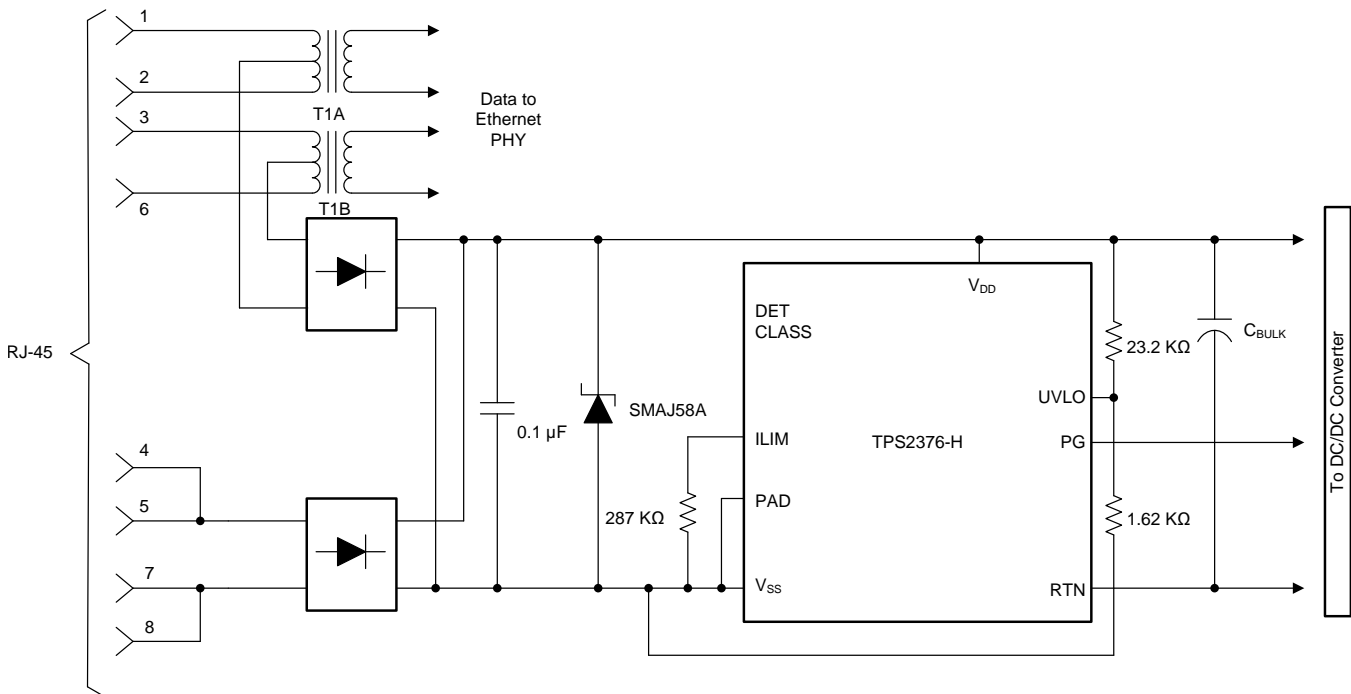

Figure 13. Typical Application Circuit

9.2.1 External Components

9.2.1.1 Detection Resistor and UVLO Divider

The UVLO divider shown in [Figure 13](#) is suitable where elimination of the detection resistor is desirable and the IEEE 802.3af compatible turn on is desired. The upper resistor dissipates about 116 mW at 55.5 V (57 V minus 1.5 V for an input diode bridge) at the maximum input, and supports 52 V. An 0805 size resistor is recommended for this resistor while an 0603 size resistor is suitable for the lower resistor.

Improved efficiency is obtained by using a detection resistor along with high-value UVLO resistors. The maximum UVLO divider resistance may be determined by considering the effect of the UVLO pin leakage current. The error is equal to the leakage current times the parallel resistance of the divider resistors. This may be simplified for the 39.5 V turn-on case to the leakage current times the lower divider resistance. The maximum resistance is the error voltage divided by the leakage current. For a 0.5% error, the maximum resistance is $(0.005 * 2.49 \text{ V}) / 1 \mu\text{A}$, or approximately 12.4 kΩ. A possible divider for a turn-on voltage of 39.5 V is 178 kΩ / 12.1 kΩ resulting in a turn-on voltage of 39.1 V. A suitable value for R_{DET} is 28.7 kΩ, yielding a detection resistance of 24.93 kΩ. The operating power loss at 55.5 V is 16 mW.

The input diode bridge's incremental resistance can be hundreds of ohms at the low currents seen at 2.7 V on the PI. The bridge resistance is in series with $R_{\text{(DET)}}$ and increases the total resistance seen by the PSE. This varies with the type of diode selected by the designer, and it is not usually specified on the diode data sheet. The value of $R_{\text{(DET)}}$ may be adjusted downwards to accommodate a particular diode type. The non-linear resistance shown in [Figure 2](#) at low currents is the result of the diodes.

9.2.1.2 Magnetics

A high-power PoE system places additional burden on power extraction from data pairs. Data transmission properties must be maintained while carrying higher current and withstanding higher difference current between the conductors in a pair. This difference current is the result of unbalanced resistances between the conductors of a pair (see IEEE 802.3af annex 33E).

Either a higher current center-tapped transformer as shown in [Figure 13](#), or the addition of a center-tapped inductor, can be implemented. Proper termination is required around the transformer to provide correct impedance matching and to avoid radiated and conducted emissions.

Typical Application (continued)

9.2.1.3 Input Diodes or Diode Bridges

The IEEE 802.3af requires the PD to accept power on either set of input pairs in either polarity. This requirement is satisfied by using two full-wave input bridge rectifiers as shown in [Figure 13](#). The full configuration may not be required when a custom high-power system is implemented. Silicon p-n diodes with a 1-A or 1.5-A rating and a minimum breakdown of 100 V are recommended, however Schottky diodes will yield a somewhat lower power loss. Diodes exhibit large dynamic resistance under low-current operating conditions such as in detection. The diodes should be tested for their behavior under this condition. The total forward drops must be less than 1.5 V at 500 μ A and at the lowest operating temperature.

9.2.1.4 Input Capacitor

The IEEE 802.3af requires a PD input capacitance between 0.05 μ F and 0.12 μ F during detection. This capacitor should be located directly adjacent to the TPS2376-H as shown in [Figure 13](#). A 100-V, 10%, X7R ceramic capacitor meets the specification over a wide temperature range.

9.2.1.5 Load Capacitor

The IEEE 802.3af specification requires that the PD maintain a minimum load capacitance of 5 μ F.

A PD can fail the dc MPS requirement if the load current to capacitance ratio is too small. This is caused by having a long input current dropout after a drop in input voltage. The PD should begin to draw input current within 300 ms of an abrupt 13 V input droop.

A particular design may have a tendency to cause ringing at the RTN pin during startup, inadvertent hot-plugs of the PoE input, or plugging in a wall adapter. It is recommended that a minimum value of 1 μ F be used at the output of the TPS2376-H if downstream filtering prevents placing the larger bulk capacitor right on the output. When using ORing option 2, it is recommended that a large capacitor such as a 22 μ F be placed across the TPS2376-H output.

9.2.1.6 Transient Suppressor

Voltage transients on the TPS2376-H can be caused by connecting or disconnecting the PD, or by other environmental conditions like ESD. A transient voltage suppressor, such as the SMAJ58A, should be installed after the bridge and across the TPS2376-H input as shown in [Figure 13](#).

Some form of protection may be required from $V_{(VDD-RTN)}$ if adequate capacitance is not present. RTN is a high impedance node when the MOSFET is off. Some topologies may cause large transients to occur on this pin when the PD is plugged into an active supply.

10 Power Supply Recommendations

10.1 Maintain Power Signature

Once a valid PD has been detected and powered, the PSE uses the maintain power signature (MPS) to determine when to remove power from the PI. The PSE removes power from that output port if it detects loss of MPS for 300 ms or more. A valid MPS requires that the PD to draw at least 10 mA and have an ac impedance less than 26.25 k Ω in parallel with 0.05 μ F.

10.2 DC/DC Converter Startup

The PSE and TPS2376-H are power and current limited sources, which imposes certain constraints on the PD power supply design. Improper design of the system can prevent PD startup with some combinations of Ethernet lines and PSE sources. The root of most startup problems revolves around the dc/dc converter.

Dc/dc converters have a constant input power characteristic that causes them to draw high currents at low voltage. Also, a converter may draw in excess of 125% of its rated power during startup when the output voltage approaches its regulated value, and the output capacitors are charging while the load draws its full power. These characteristics lead to two undesired events. First, if the converter starts up during inrush, it can draw more current than available from the TPS2376-H and cause the startup cycle to fail. Second, if the converter startup current exceeds the TPS2376-H current limit, it may discharge the bulk capacitor until $V_{(RTN-VSS)}$ exceeds 10 V and forces the TPS2376-H into inrush.

DC/DC Converter Startup (continued)

The following guidelines should be used:

1. Set the TPS2376-H inrush to a moderate value such as 140 mA.
2. Hold the dc/dc converter off during inrush using PG.
3. Implement a softstart that keeps the peak start-up current below 600 mA, and preferably only a modest amount over the operating current, at the minimum PSE voltage and maximum feed resistance.
4. If step 3 cannot be met, the bulk input capacitor should not discharge more than 8 V during start-up at the minimum PSE voltage and maximum feed resistance. Start-up must be completed in less than 50 ms.

Step 4 requires a balance between the converter output capacitance, load, and input bulk capacitance. While there are some cases which may not require all these measures, it is always a good practice to follow them.

Downstream converters that use PG control are turned off during a hard fault or thermal cycle, and will go through an orderly restart once the bulk capacitor is recharged. Converters that do not use PG need to permit a restart by either drawing less current than the inrush current limit provides, or by disabling long enough to allow the bulk capacitor to recharge. A converter that has bootstrap startup can be designed to accomplish this goal.

10.3 Auxiliary Power Source ORing

Many PoE-capable devices are designed to operate from either a wall adapter or PoE power. A local power solution adds cost and complexity, but allows a product to be used regardless of PoE availability. Attempting to create solutions where the two power sources coexist in a specific controlled manner results in additional complexity, and is not generally recommended. Figure 14 demonstrates three methods of diode ORing external power into a PD. Option 1 inserts power on the output side of the PoE power conversion. Option 2 inserts power on the TPS2376-H output. Option 3 applies power to the TPS2376-H input. Each of these options has advantages and disadvantages. The wall adapter must meet a minimum 1500-Vac dielectric withstand test voltage to the ac input power and to ground for options 2 and 3.

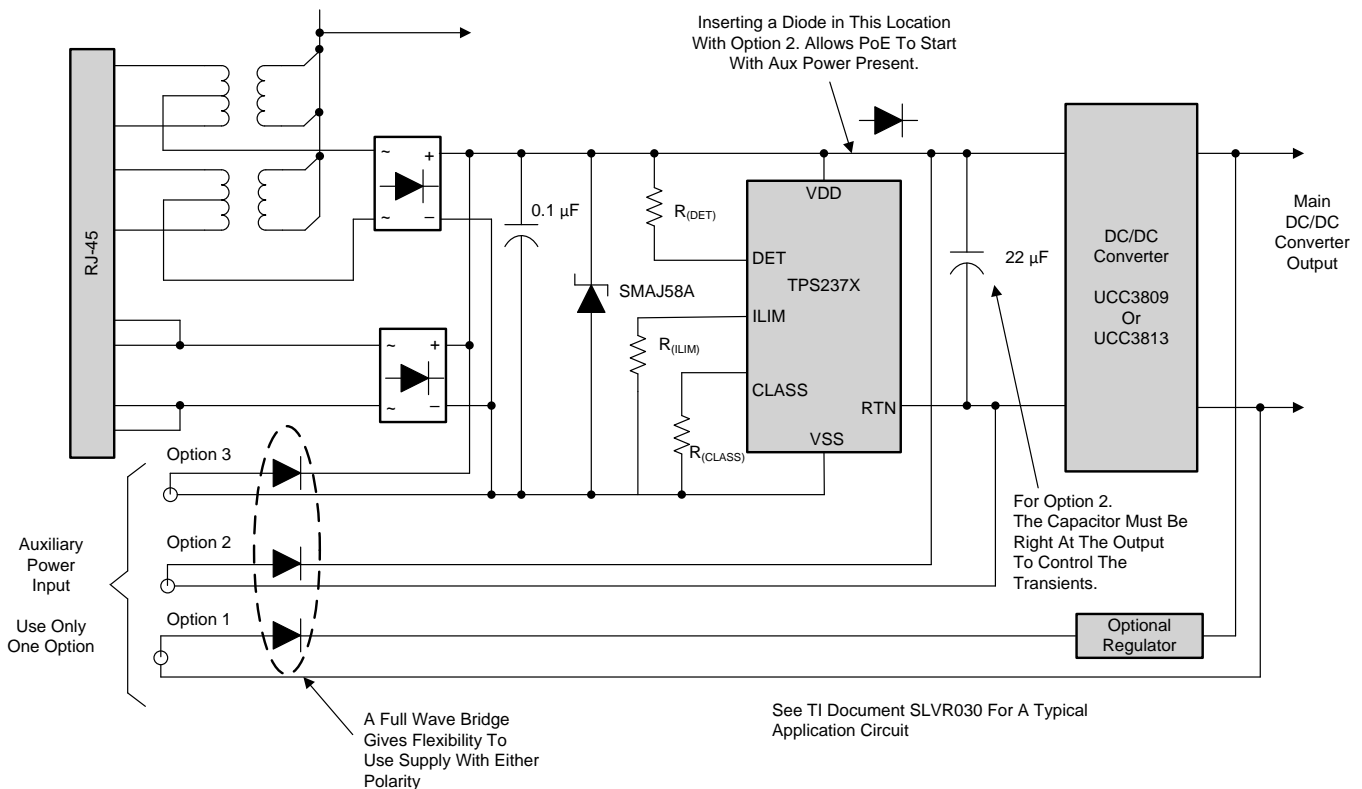

Figure 14. Auxiliary Power ORing

Auxiliary Power Source ORing (continued)

Option 1 consists of ORing power to the output of the PoE dc/dc converter. This option is preferred in cases where PoE is added to an existing design that uses a low-voltage wall adapter. The relatively large PD capacitance reduces the potential for harmful transients when the adapter is plugged in. The wall adapter output may be grounded if the PD incorporates an isolated converter. This solution requires two separate regulators, but low-voltage adapters are readily available. The PoE power can be given priority by setting its output voltage above the adapter's.

Option 2 has the benefits that the adapter voltage may be lower than the TPS2376-H UVLO, and that the bulk capacitor shown controls voltage transients caused by plugging an adapter in. The capacitor size and location are chosen to control the amount of ringing that can occur on this node, which can be affected by additional filtering components specific to a dc/dc converter design. The optional diode blocks the adapter voltage from reverse biasing the input, and allows a PoE source to supply power provided that the PSE output voltage is greater than the adapter voltage. The penalty of the diode is an additional power loss when running from PSE power. The PSE may not be able to detect and start powering without the diode. This means that the adapter may continue to power the PD until removed. Auxiliary voltage sources can be selected to be above or below the PoE operational voltage range. If automatic PoE precedence is desired when using the low-voltage auxiliary source option, make sure that the TPS2376-H inrush program limit is set higher than the maximum converter input current at its lowest operating voltage. It is difficult to use PG with the low-voltage auxiliary source because the converter must operate during a condition when the TPS2376-H would normally disable it. Circuits may be designed to force operation from one source or the other depending on the desired operation and the auxiliary source voltage chosen. However, they are not recommended because they increase complexity and thus cost.

Option 3 inserts the power before the TPS2376-H. The adapter output voltage must meet the TPS2376-H UVLO turn-on requirement and limit the maximum voltage to 57 V. This option provides a valid power-good signal and simplifies power priority issues. Option 3 is the most likely to create transient voltage problems when a powered adapter is plugged in. This causes the cabling inductance and PD input capacitance to ring to a high voltage that must be clamped by the TVS. If the adapter applies voltage to the PD before the PSE, it prevents the PSE from detecting the PD. If the PSE is already powering the PD when the adapter is plugged in, priority is given to the higher supply voltage.

11 Layout

11.1 Layout Guidelines

The layout of the PoE front end must use good practices for power and EMI/ESD. A basic set of recommendations include:

1. The parts placement must be driven by the power flow in a point-to-point manner such as RJ-45 → Ethernet interface → diode bridges → TVS and 0.1- μ F capacitor → TPS2376-H → output capacitor.
2. There should not be any crossovers of signals from one part of the flow to another.
3. All leads should be as short as possible with wide power traces and paired signal and return.
4. Spacing consistent with safety standards like IEC60950 must be observed between the 48-V input voltage rails and between the input and an isolated converter output.
5. The TPS2376-H should be over a local ground plane or fill area referenced to VSS.
6. Large SMT component pads should be used on power dissipating devices such as the diodes and the TPS2376-H.

Use of generous copper area on VSS and to help the PCB spread and dissipate the heat is recommended. Assuming a worst-case power dissipation of 0.4 W, the required thermal resistance may be calculated as: $\theta_{JA} = (t_{J_MAX} - t_{A_MAX}) / P$. A thermal resistance of 50°C/W is required for a junction temperature of 105°C at an ambient of 85°C. The effect of additional local heating on the circuit board from other devices must be considered. The thermal resistance cases provided in the dissipation rating table should be used as a guide in determining the required area.

Layout Guidelines (continued)

The [Layout Example](#) provides an example of a single sided layout with liberal copper plane areas to help spread the heat. The active circuit area could be reduced by locating the small resistors on the backside of the board. The TPS2376-H PowerPad is covered by copper fill, which has multiple vias to a backside mirror-image fill. There are 5 small vias under the PowerPad per the guidelines of SLMA0002 which are masked by the graphics of the tool. The fills for RTN and VDD also help spread the heat. A copper fill clearance of 0.030 inches was used for VDD to RTN or VSS. A spacing of 0.025 inches for the full PoE voltage was met elsewhere.

11.2 Layout Example

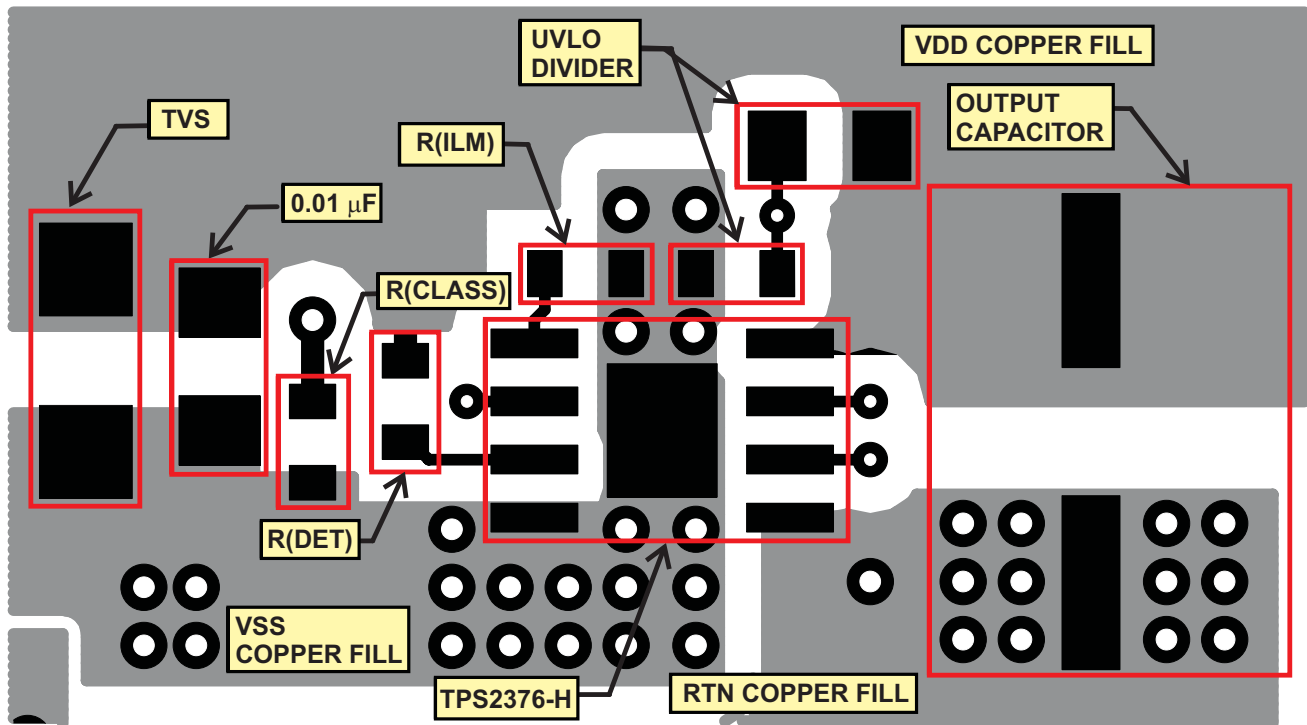

11.3 Thermal Protection

The TPS2376-H may overheat if the ambient temperature becomes excessive, or if it operates for an extended period of time in classification or current limit. The TPS2376-H protects itself by disabling the RTN and CLASS pins and pulling PG low when the internal die temperature reaches about 140°C. It automatically restarts when the die temperature has fallen approximately 20°C. If $V_{(RTN-VSS)}$ is less than 10 V when the TPS2376-H restarts, the current limit remains at 765 mA and PG goes open-drain. If the overload has caused $V_{(RTN-VSS)}$ to exceed 10 V while disabled, the current limit is set to the inrush level and PG remains low. This process is referred to as thermal cycling. Thermal protection is active whenever the TPS2376-H is not in detection.

Short periods of thermal cycling do not significantly impact the reliability or life expectancy, but prolonged periods may. Other components in the power path can be overstressed if this condition exists for a prolonged time as well.

11.4 ESD

The TPS2376-H has been tested using the surge of EN61000-4-2 in evaluation circuit similar to the [Typical Application Circuit](#). The levels used were 8-kV contact discharge and 15-kV air discharge. Surges were applied between the RJ-45 and the outputs, and between an auxiliary power input jack and the dc outputs. No failures were observed.

ESD requirements for a unit that incorporates the TPS2376-H have much broader scope and operational implications than those used in TI's testing. Unit level requirements should not be confused with EVM testing that only validated the TPS2376-H.

12 Device and Documentation Support

12.1 Documentation Support

12.1.1 Related Documentation

For related documentation see the following:

- [High Power PoE PD Using the TPS2375/77-1](#)

12.2 Receiving Notification of Documentation Updates

To receive notification of documentation updates, navigate to the device product folder on ti.com. In the upper right corner, click on *Alert me* to register and receive a weekly digest of any product information that has changed. For change details, review the revision history included in any revised document.

12.3 Community Resources

The following links connect to TI community resources. Linked contents are provided "AS IS" by the respective contributors. They do not constitute TI specifications and do not necessarily reflect TI's views; see TI's [Terms of Use](#).

TI E2E™ Online Community *TI's Engineer-to-Engineer (E2E) Community*. Created to foster collaboration among engineers. At e2e.ti.com, you can ask questions, share knowledge, explore ideas and help solve problems with fellow engineers.

Design Support *TI's Design Support* Quickly find helpful E2E forums along with design support tools and contact information for technical support.

12.4 Trademarks

PowerPad, E2E are trademarks of Texas Instruments.

12.5 Electrostatic Discharge Caution



This integrated circuit can be damaged by ESD. Texas Instruments recommends that all integrated circuits be handled with appropriate precautions. Failure to observe proper handling and installation procedures can cause damage.

ESD damage can range from subtle performance degradation to complete device failure. Precision integrated circuits may be more susceptible to damage because very small parametric changes could cause the device not to meet its published specifications.

12.6 Glossary

[SLYZ022](#) — *TI Glossary*.

This glossary lists and explains terms, acronyms, and definitions.

13 Mechanical, Packaging, and Orderable Information

The following pages include mechanical, packaging, and orderable information. This information is the most current data available for the designated devices. This data is subject to change without notice and revision of this document. For browser-based versions of this data sheet, refer to the left-hand navigation.

PACKAGING INFORMATION

Orderable part number	Status (1)	Material type (2)	Package Pins	Package qty Carrier	RoHS (3)	Lead finish/ Ball material (4)	MSL rating/ Peak reflow (5)	Op temp (°C)	Part marking (6)
TPS2376DDA-H	Active	Production	SO PowerPAD (DDA) 8	75 TUBE	Yes	NIPDAU	Level-1-260C-UNLIM	-40 to 85	2376H
TPS2376DDA-H.A	Active	Production	SO PowerPAD (DDA) 8	75 TUBE	Yes	NIPDAU	Level-1-260C-UNLIM	-40 to 85	2376H
TPS2376DDA-HG4	Active	Production	SO PowerPAD (DDA) 8	75 TUBE	Yes	NIPDAU	Level-1-260C-UNLIM	-40 to 85	2376H
TPS2376DDAR-H	Active	Production	SO PowerPAD (DDA) 8	2500 LARGE T&R	Yes	NIPDAU	Level-1-260C-UNLIM	-40 to 85	2376H
TPS2376DDAR-H.A	Active	Production	SO PowerPAD (DDA) 8	2500 LARGE T&R	Yes	NIPDAU	Level-1-260C-UNLIM	-40 to 85	2376H
TPS2376DDAR-HG4	Active	Production	SO PowerPAD (DDA) 8	2500 LARGE T&R	Yes	NIPDAU	Level-1-260C-UNLIM	-40 to 85	2376H
TPS2376DDAR-HG4.A	Active	Production	SO PowerPAD (DDA) 8	2500 LARGE T&R	Yes	NIPDAU	Level-1-260C-UNLIM	-40 to 85	2376H

(1) **Status:** For more details on status, see our [product life cycle](#).

(2) **Material type:** When designated, preproduction parts are prototypes/experimental devices, and are not yet approved or released for full production. Testing and final process, including without limitation quality assurance, reliability performance testing, and/or process qualification, may not yet be complete, and this item is subject to further changes or possible discontinuation. If available for ordering, purchases will be subject to an additional waiver at checkout, and are intended for early internal evaluation purposes only. These items are sold without warranties of any kind.

(3) **RoHS values:** Yes, No, RoHS Exempt. See the [TI RoHS Statement](#) for additional information and value definition.

(4) **Lead finish/Ball material:** Parts may have multiple material finish options. Finish options are separated by a vertical ruled line. Lead finish/Ball material values may wrap to two lines if the finish value exceeds the maximum column width.

(5) **MSL rating/Peak reflow:** The moisture sensitivity level ratings and peak solder (reflow) temperatures. In the event that a part has multiple moisture sensitivity ratings, only the lowest level per JEDEC standards is shown. Refer to the shipping label for the actual reflow temperature that will be used to mount the part to the printed circuit board.

(6) **Part marking:** There may be an additional marking, which relates to the logo, the lot trace code information, or the environmental category of the part.

Multiple part markings will be inside parentheses. Only one part marking contained in parentheses and separated by a "~" will appear on a part. If a line is indented then it is a continuation of the previous line and the two combined represent the entire part marking for that device.

Important Information and Disclaimer: The information provided on this page represents TI's knowledge and belief as of the date that it is provided. TI bases its knowledge and belief on information provided by third parties, and makes no representation or warranty as to the accuracy of such information. Efforts are underway to better integrate information from third parties. TI has taken and continues to take reasonable steps to provide representative and accurate information but may not have conducted destructive testing or chemical analysis on incoming materials and chemicals. TI and TI suppliers consider certain information to be proprietary, and thus CAS numbers and other limited information may not be available for release.

In no event shall TI's liability arising out of such information exceed the total purchase price of the TI part(s) at issue in this document sold by TI to Customer on an annual basis.

TAPE AND REEL INFORMATION

QUADRANT ASSIGNMENTS FOR PIN 1 ORIENTATION IN TAPE

*All dimensions are nominal

Device	Package Type	Package Drawing	Pins	SPQ	Reel Diameter (mm)	Reel Width W1 (mm)	A0 (mm)	B0 (mm)	K0 (mm)	P1 (mm)	W (mm)	Pin1 Quadrant
TPS2376DDAR-H	SO PowerPAD	DDA	8	2500	330.0	12.4	6.4	5.2	2.1	8.0	12.0	Q1
TPS2376DDAR-HG4	SO PowerPAD	DDA	8	2500	330.0	12.4	6.4	5.2	2.1	8.0	12.0	Q1

TAPE AND REEL BOX DIMENSIONS



*All dimensions are nominal

Device	Package Type	Package Drawing	Pins	SPQ	Length (mm)	Width (mm)	Height (mm)
TPS2376DDAR-H	SO PowerPAD	DDA	8	2500	358.0	335.0	35.0
TPS2376DDAR-HG4	SO PowerPAD	DDA	8	2500	358.0	335.0	35.0

TUBE



*All dimensions are nominal

Device	Package Name	Package Type	Pins	SPQ	L (mm)	W (mm)	T (μm)	B (mm)
TPS2376DDA-H	DDA	HSOIC	8	75	390	7.8	3800	3.5
TPS2376DDA-H.A	DDA	HSOIC	8	75	390	7.8	3800	3.5
TPS2376DDA-HG4	DDA	HSOIC	8	75	390	7.8	3800	3.5

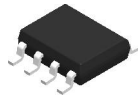

Images above are just a representation of the package family, actual package may vary.
Refer to the product data sheet for package details.

DDA0008J



PACKAGE OUTLINE

PowerPAD™ SOIC - 1.7 mm max height

PLASTIC SMALL OUTLINE

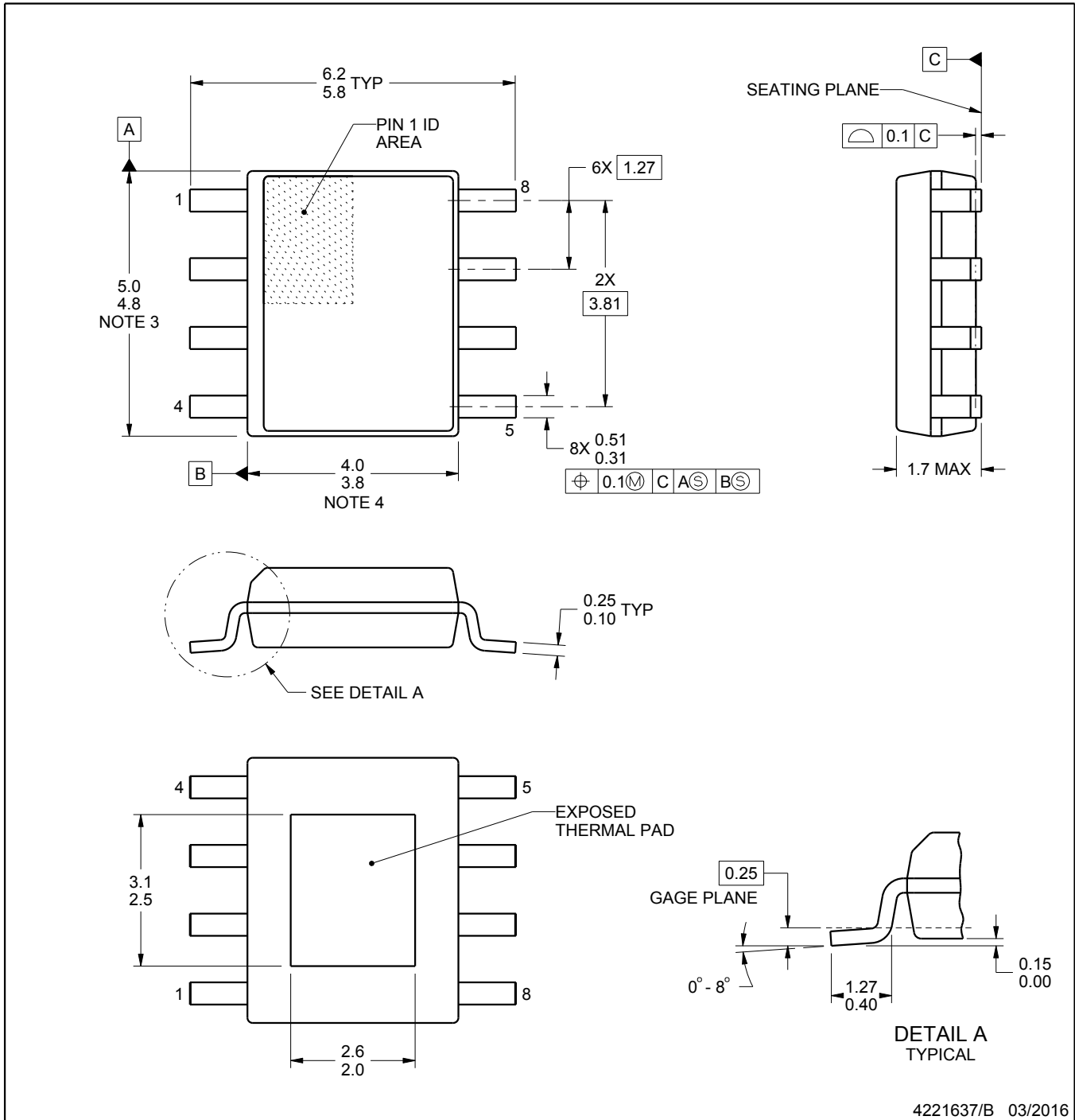

4221637/B 03/2016

PowerPAD is a trademark of Texas Instruments.

NOTES:

1. All linear dimensions are in millimeters. Any dimensions in parenthesis are for reference only. Dimensioning and tolerancing per ASME Y14.5M.
2. This drawing is subject to change without notice.
3. This dimension does not include mold flash, protrusions, or gate burrs. Mold flash, protrusions, or gate burrs shall not exceed 0.15 mm per side.
4. This dimension does not include interlead flash. Interlead flash shall not exceed 0.25 mm per side.
5. Reference JEDEC registration MS-012, variation BA.

EXAMPLE BOARD LAYOUT

DDA0008J

PowerPAD™ SOIC - 1.7 mm max height

PLASTIC SMALL OUTLINE

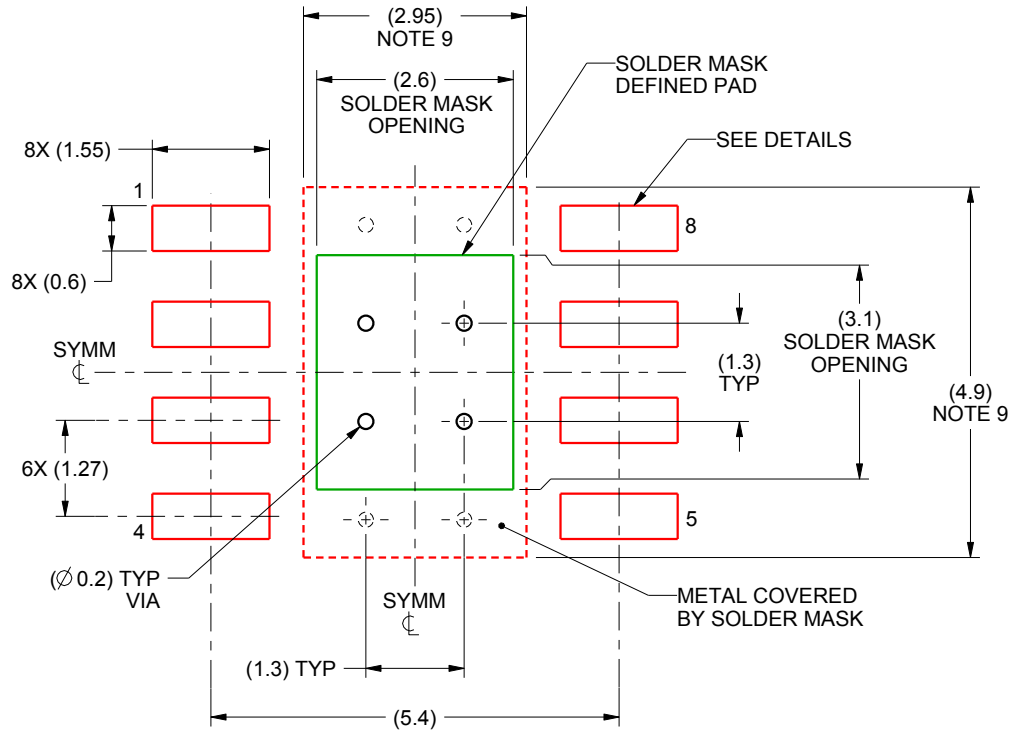

LAND PATTERN EXAMPLE
SCALE:10X

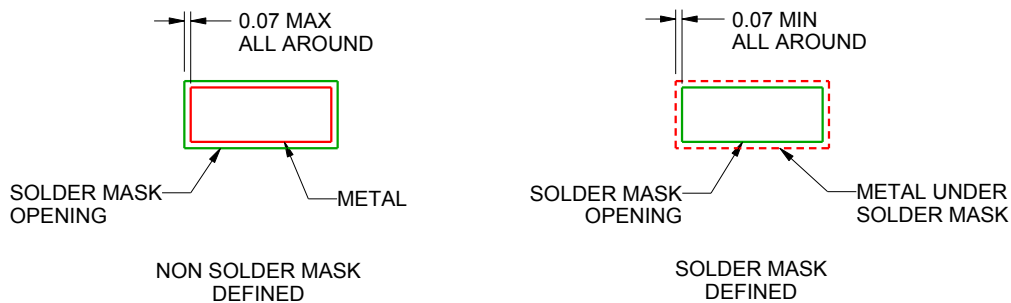

SOLDER MASK DETAILS

4221637/B 03/2016

NOTES: (continued)

6. Publication IPC-7351 may have alternate designs.
7. Solder mask tolerances between and around signal pads can vary based on board fabrication site.
8. This package is designed to be soldered to a thermal pad on the board. For more information, see Texas Instruments literature numbers SLMA002 (www.ti.com/lit/slma002) and SLMA004 (www.ti.com/lit/slma004).
9. Size of metal pad may vary due to creepage requirement.

EXAMPLE STENCIL DESIGN

DDA0008J

PowerPAD™ SOIC - 1.7 mm max height

PLASTIC SMALL OUTLINE

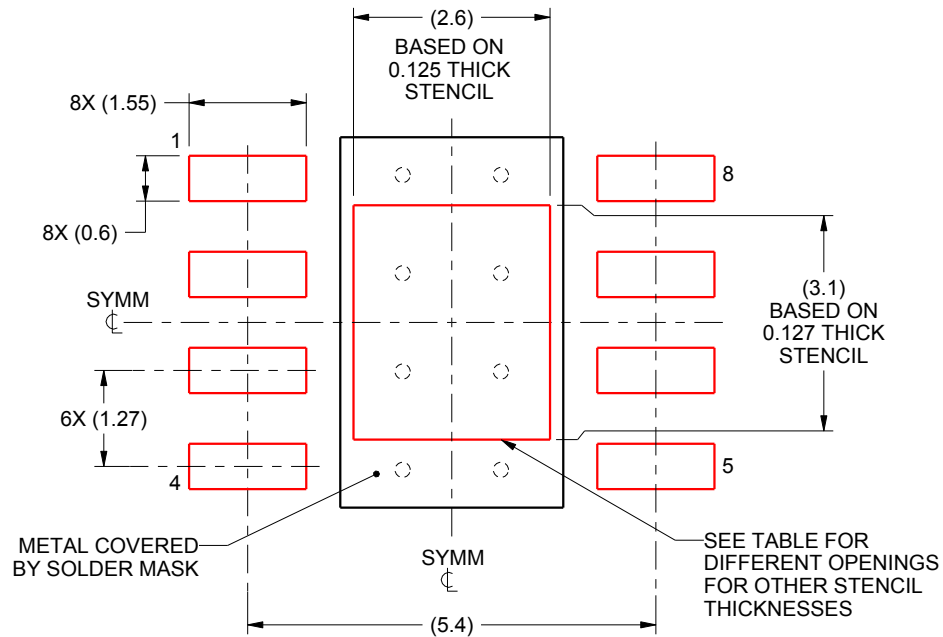

SOLDER PASTE EXAMPLE
 EXPOSED PAD
 100% PRINTED SOLDER COVERAGE BY AREA
 SCALE:10X

STENCIL THICKNESS	SOLDER STENCIL OPENING
0.1	2.91 X 3.47
0.125	2.6 X 3.1 (SHOWN)
0.150	2.37 X 2.83
0.175	2.20 X 2.62

4221637/B 03/2016

NOTES: (continued)

- 10. Laser cutting apertures with trapezoidal walls and rounded corners may offer better paste release. IPC-7525 may have alternate design recommendations.
- 11. Board assembly site may have different recommendations for stencil design.

IMPORTANT NOTICE AND DISCLAIMER

TI PROVIDES TECHNICAL AND RELIABILITY DATA (INCLUDING DATASHEETS), DESIGN RESOURCES (INCLUDING REFERENCE DESIGNS), APPLICATION OR OTHER DESIGN ADVICE, WEB TOOLS, SAFETY INFORMATION, AND OTHER RESOURCES "AS IS" AND WITH ALL FAULTS, AND DISCLAIMS ALL WARRANTIES, EXPRESS AND IMPLIED, INCLUDING WITHOUT LIMITATION ANY IMPLIED WARRANTIES OF MERCHANTABILITY, FITNESS FOR A PARTICULAR PURPOSE OR NON-INFRINGEMENT OF THIRD PARTY INTELLECTUAL PROPERTY RIGHTS.

These resources are intended for skilled developers designing with TI products. You are solely responsible for (1) selecting the appropriate TI products for your application, (2) designing, validating and testing your application, and (3) ensuring your application meets applicable standards, and any other safety, security, regulatory or other requirements.

These resources are subject to change without notice. TI grants you permission to use these resources only for development of an application that uses the TI products described in the resource. Other reproduction and display of these resources is prohibited. No license is granted to any other TI intellectual property right or to any third party intellectual property right. TI disclaims responsibility for, and you fully indemnify TI and its representatives against any claims, damages, costs, losses, and liabilities arising out of your use of these resources.

TI's products are provided subject to [TI's Terms of Sale](#), [TI's General Quality Guidelines](#), or other applicable terms available either on ti.com or provided in conjunction with such TI products. TI's provision of these resources does not expand or otherwise alter TI's applicable warranties or warranty disclaimers for TI products. Unless TI explicitly designates a product as custom or customer-specified, TI products are standard, catalog, general purpose devices.

TI objects to and rejects any additional or different terms you may propose.

Copyright © 2025, Texas Instruments Incorporated

Last updated 10/2025