

TPS62852x-Q1 2.7V to 6V, 1A, 2A, 3A, Automotive, Step-Down Converters in a WSON Package

1 Features

- AEC-Q100 qualified for automotive applications
 - Device temperature grade 1: -40°C to $+125^{\circ}\text{C}$ T_A
- Wettable flanks
- Designed for low EMI requirements
 - Optional pseudo-random spread spectrum reduces peak emissions
- $T_J = -40^{\circ}\text{C}$ to $+150^{\circ}\text{C}$
- Family of 1A, 2A, and 3A (continuous) converters
- Input voltage range: 2.7V to 6V
- Quiescent current: 21 μA typical
- Shutdown current: 1.5 μA typical
- Output voltage from 0.6V to 5.5V
- Output voltage accuracy $\pm 1\%$ (PWM operation)
- Options of forced PWM or PWM, PFM operation
- Switching frequency in PWM: 2.25MHz
- Adjustable soft start-up to 10ms
- Precise ENABLE input allows:
 - User-defined undervoltage lockout
 - Exact sequencing
- Active output discharge
- Foldback overcurrent protection – optional
- Power-good output with window comparator

2 Applications

- [Advanced driver assistance systems \(ADAS\) camera](#)
- [ADAS sensor fusion and surround view ECU](#)
- [Hybrid and reconfigurable instrument cluster](#)
- [Head unit and telematics control unit](#)
- [External audio amplifier](#)

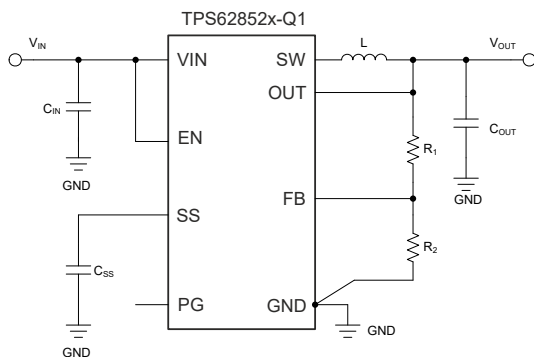

Simplified Schematic

3 Description

The TPS62852x-Q1 are a family of pin-to-pin, 1A, 2A, and 3A, high efficiency, easy-to-use, synchronous step-down DC/DC converters. These devices are based on a peak current mode control topology and support tight switching frequency variation. These devices are designed for automotive applications such as infotainment and advanced driver assistance systems. Low resistive switches allow up to 3A continuous output current. In the TPS62852x-Q1, the switching frequency is internally fixed at 2.25MHz. The TPS62852x-Q1 automatically selects pulse width modulation (PWM) for higher power demand and pulse frequency mode (PFM) for power saving operation. This selection maintains high efficiency across the whole load range. The device exists also in options with forced PWM in cases where frequency stability requirements dominate. The family provides a 1% output voltage accuracy over the full temperature range in PWM mode, which helps designing power supplies for devices with very tight supply voltage accuracy requirements.

The TPS62852x-Q1 is available in an 8-pin, 2.0mm × 1.5mm, WSON package.

Device Information

PART NUMBER ⁽³⁾	OUTPUT CURRENT	PACKAGE ⁽¹⁾	PACKAGE SIZE ⁽²⁾
TPS628521-Q1	1A	DLS (WSON-HR, 8)	2.00mm × 1.50mm
TPS628522-Q1	2A		
TPS628523-Q1	3A		

- (1) For more information, see [Section 8](#).
- (2) The package size (length × width) is a nominal value and includes pins, where applicable.
- (3) See the [Device Comparison Table](#).

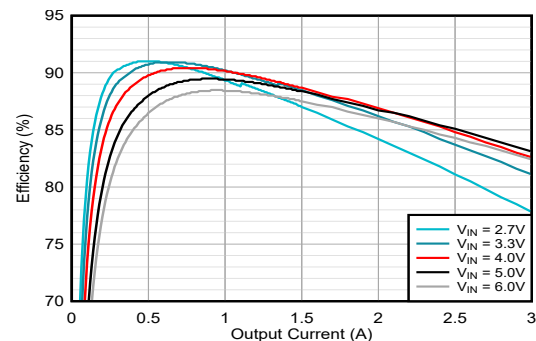

Efficiency vs I_{OUT} , $V_{OUT} = 1.1\text{V}$



Table of Contents

1 Features	1	6.2 Receiving Notification of Documentation Updates.....	5
2 Applications	1	6.3 Support Resources.....	5
3 Description	1	6.4 Trademarks.....	5
4 Device Comparison Table	3	6.5 Electrostatic Discharge Caution.....	5
5 Pin Configuration and Functions	4	6.6 Glossary.....	5
6 Device and Documentation Support	5	7 Revision History	5
6.1 Device Support.....	5	8 Mechanical, Packaging, and Orderable Information	6

4 Device Comparison Table

DEVICE NUMBER	OUTPUT CURRENT	OPERATION MODE	SSC	FOLDBACK CURRENT LIMIT	TYPICAL OUTPUT CAPACITOR	INDUCTOR	OUTPUT VOLTAGE	PACKAGE TYPE
TPS628523SAWDLRQ1	3A	FPWM	ON	OFF	1 × 22uF	470nH	Adjustable	WDLS ⁽²⁾
TPS628523PAWDLRQ1	3A	FPWM	ON	OFF	2 × 22uF	470nH	Adjustable	WDLS ⁽²⁾
TPS628523HAWDLRQ1	3A	FPWM	ON	OFF	2 × 22uF	200nH	Adjustable	WDLS ⁽²⁾
TPS628522SAWDLRQ1	2A	FPWM	ON	OFF	1 × 22uF	470nH	Adjustable	WDLS ⁽²⁾
TPS628522PAWDLRQ1	2A	FPWM	ON	OFF	2 × 22uF	470nH	Adjustable	WDLS ⁽²⁾
TPS628522HAWDLRQ1	2A	FPWM	ON	OFF	2 × 22uF	200nH	Adjustable	WDLS ⁽²⁾
TPS628521SAWDLRQ1	1A	FPWM	ON	OFF	1 × 22uF	470nH	Adjustable	WDLS ⁽²⁾
TPS628523CAWDLRQ1 ⁽¹⁾	3A	FPWM	ON	OFF	100uF	200nH	Adjustable	WDLS ⁽²⁾
TPS628521LKWDLRQ1 ⁽¹⁾	1A	FPWM	ON	OFF	1 × 22uF	470nH	1.8V	WDLS ⁽²⁾
TPS628523SADLSRQ1	3A	FPWM	OFF	OFF	1 × 22uF	470nH	Adjustable	DLS
TPS628523SDLSRQ1 ⁽¹⁾	3A	PFM/PWM	OFF	OFF	1 × 22uF	470nH	Adjustable	DLS
TPS628523PADLSRQ1	3A	FPWM	OFF	OFF	2 × 22uF	470nH	Adjustable	DLS
TPS628523PDLSRQ1	3A	PFM/PWM	OFF	OFF	2 × 22uF	470nH	Adjustable	DLS
TPS628523HADLSRQ1	3A	FPWM	OFF	OFF	2 × 22uF	200nH	Adjustable	DLS
TPS628522SADLSRQ1	2A	FPWM	OFF	OFF	1 × 22uF	470nH	Adjustable	DLS
TPS628522PADLSRQ1 ⁽¹⁾	2A	FPWM	OFF	OFF	2 × 22uF	470nH	Adjustable	DLS
TPS628522HADLSRQ1	2A	FPWM	OFF	OFF	2 × 22uF	200nH	Adjustable	DLS
TPS628521SADLSRQ1 ⁽¹⁾	1A	FPWM	OFF	OFF	1 × 22uF	470nH	Adjustable	DLS

- (1) Preview information (not production data)
(2) WDLS - wettable flanks

The TPS628523S and P versions use a 470nH inductor and can be used interchangeably with industry standard devices. The TPS628523H is an enhanced version for 200nH inductors with 2 × 22uF output capacitors. 200nH inductors have lower DC resistance and can have a smaller form factor compared to a 470nH inductor with the same current carrying capability. The TPS628523H also offers best transient behavior and can additionally support higher output capacitance for transient suppression down to very few mV. The TPS628523C also supports 200nH and has the compensation adapted for very large output capacitance for best transient response.

5 Pin Configuration and Functions

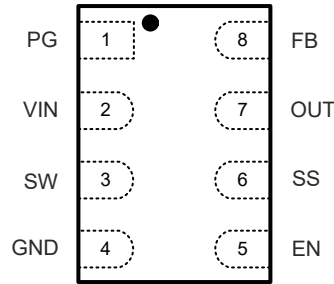

Figure 5-1. 8-Pin WSON-HR DLS (Top View)

Table 5-1. Pin Functions

PIN		TYPE ⁽¹⁾	DESCRIPTION
NAME	NO.		
PG	1	O	Open-drain power-good output
VIN	2	—	Power supply input. Make sure the input capacitor is connected as close as possible between the VIN and GND pins.
SW	3	—	This pin is the switch pin of the converter and is connected to the internal power MOSFETs.
GND	4	—	Ground pin
EN	5	I	This pin is the enable pin of the device. Connect to logic low to disable the device. Pull high to enable the device. Do not leave this pin unconnected.
SS	6	I	Soft-Start pin. An external capacitor connected from this pin to GND defines the rise time for the internal reference voltage.
OUT	7	I	Output voltage sense pin. Connect the positive terminal of the output capacitor closest to the load to this pin.
FB	8	I	Voltage feedback input. Connect the resistive output voltage divider to this pin. On device versions with fixed output voltage connect this pin directly to the positive terminal of the output capacitor closest to the inductor.

(1) I = input, O = output

6 Device and Documentation Support

6.1 Device Support

6.1.1 Third-Party Products Disclaimer

TI'S PUBLICATION OF INFORMATION REGARDING THIRD-PARTY PRODUCTS OR SERVICES DOES NOT CONSTITUTE AN ENDORSEMENT REGARDING THE SUITABILITY OF SUCH PRODUCTS OR SERVICES OR A WARRANTY, REPRESENTATION OR ENDORSEMENT OF SUCH PRODUCTS OR SERVICES, EITHER ALONE OR IN COMBINATION WITH ANY TI PRODUCT OR SERVICE.

6.2 Receiving Notification of Documentation Updates

To receive notification of documentation updates, navigate to the device product folder on ti.com. Click on *Notifications* to register and receive a weekly digest of any product information that has changed. For change details, review the revision history included in any revised document.

6.3 Support Resources

[TI E2E™ support forums](#) are an engineer's go-to source for fast, verified answers and design help — straight from the experts. Search existing answers or ask your own question to get the quick design help you need.

Linked content is provided "AS IS" by the respective contributors. They do not constitute TI specifications and do not necessarily reflect TI's views; see TI's [Terms of Use](#).

6.4 Trademarks

TI E2E™ is a trademark of Texas Instruments.
All trademarks are the property of their respective owners.

6.5 Electrostatic Discharge Caution



This integrated circuit can be damaged by ESD. Texas Instruments recommends that all integrated circuits be handled with appropriate precautions. Failure to observe proper handling and installation procedures can cause damage.

ESD damage can range from subtle performance degradation to complete device failure. Precision integrated circuits may be more susceptible to damage because very small parametric changes could cause the device not to meet its published specifications.

6.6 Glossary

[TI Glossary](#) This glossary lists and explains terms, acronyms, and definitions.

7 Revision History

Changes from Revision A (May 2025) to Revision B (July 2025) Page

- Added devices in WDLS package for release to production and in DLS packages with status "Preview information (not production data)". Moved devices with "Advance Information" status to release for production..... 3
- Added description about how to connect the FB pin on devices with fixed output voltage..... 4

Changes from Revision * (February 2025) to Revision A (May 2025) Page

- Changed the document status from Advance Information to Production Data..... 1
- Changed table from Preview Information to Production Data, added footnote for Advance information and added TPS628523HADLSRQ1..... 3

8 Mechanical, Packaging, and Orderable Information

The following pages include mechanical, packaging, and orderable information. This information is the most current data available for the designated devices. This data is subject to change without notice and revision of this document. For browser-based versions of this data sheet, refer to the left-hand navigation.

DLS0008A-C01



PACKAGE OUTLINE
WSON-HR - 0.8 mm max height

PLASTIC SMALL OUTLINE - NO LEAD

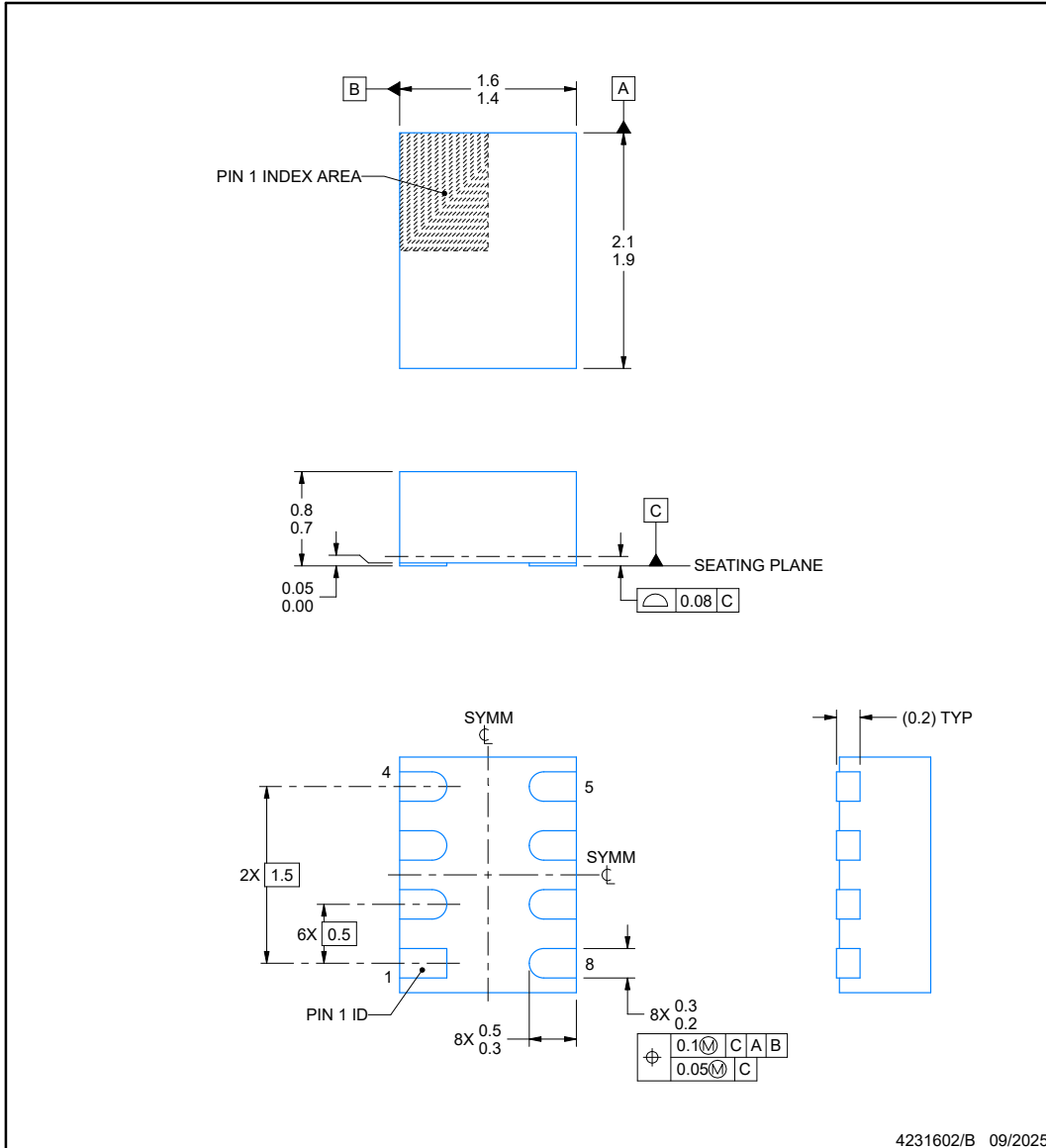

NOTES:

1. All linear dimensions are in millimeters. Any dimensions in parenthesis are for reference only. Dimensioning and tolerancing per ASME Y14.5M.
2. This drawing is subject to change without notice.

EXAMPLE BOARD LAYOUT

DLS0008A-C01

WSON-HR - 0.8 mm max height

PLASTIC SMALL OUTLINE - NO LEAD

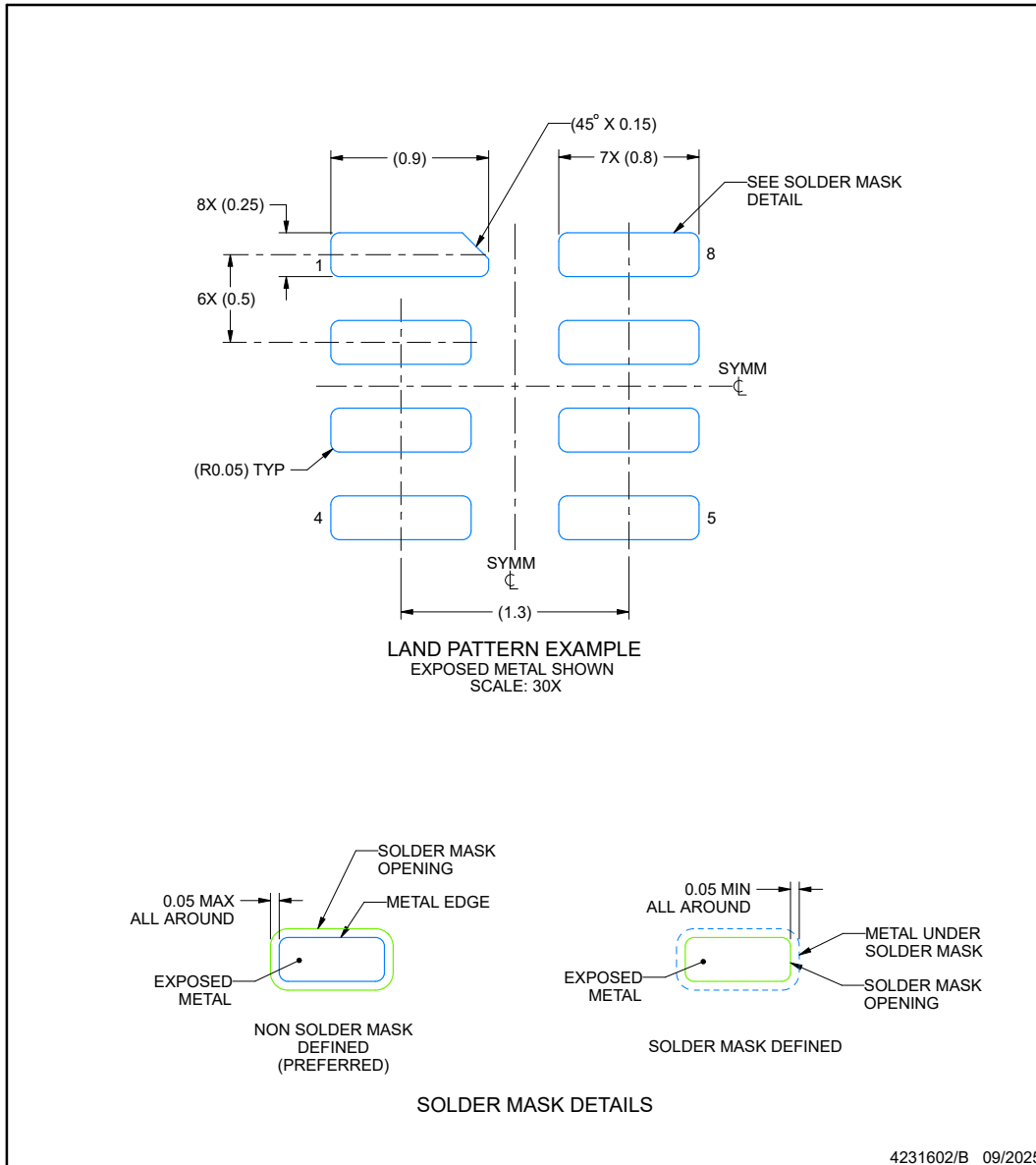

NOTES: (continued)

3. For more information, see Texas Instruments literature number SLUA271 (www.ti.com/lit/slua271).

EXAMPLE STENCIL DESIGN

DLS0008A-C01

WSON-HR - 0.8 mm max height

PLASTIC SMALL OUTLINE - NO LEAD

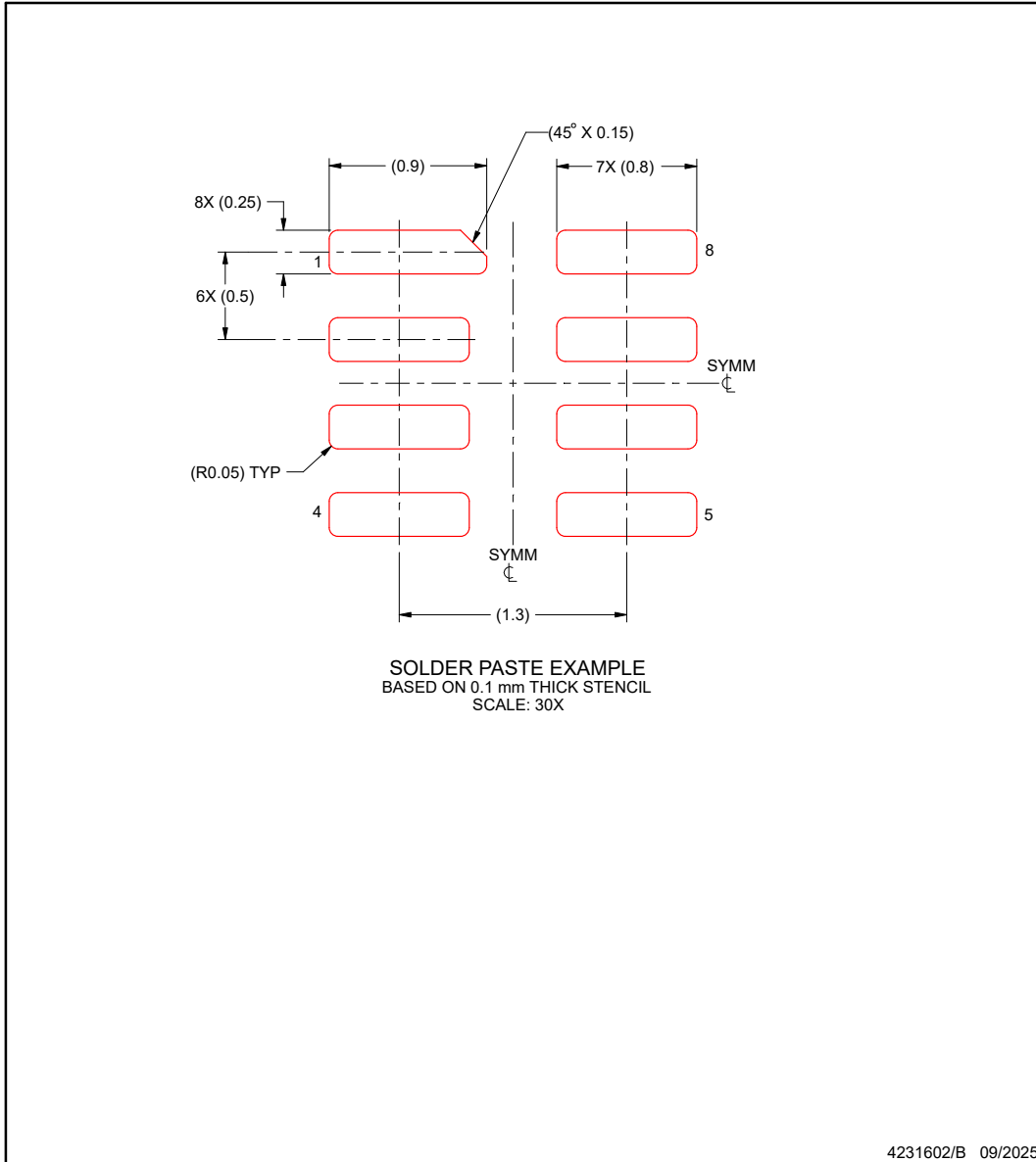

NOTES: (continued)

- 4. Laser cutting apertures with trapezoidal walls and rounded corners may offer better paste release. IPC-7525 may have alternate design recommendations.

PACKAGING INFORMATION

Orderable part number	Status (1)	Material type (2)	Package Pins	Package qty Carrier	RoHS (3)	Lead finish/ Ball material (4)	MSL rating/ Peak reflow (5)	Op temp (°C)	Part marking (6)
TPS628522HADLSRQ1	Active	Production	WSON-HR (DLS) 8	3000 LARGE T&R	Yes	SN	Level-1-260C-UNLIM	-40 to 125	1XD
TPS628522SADLSRQ1	Active	Production	WSON-HR (DLS) 8	3000 LARGE T&R	Yes	SN	Level-1-260C-UNLIM	-40 to 125	1XC
TPS628523HADLSRQ1	Active	Production	WSON-HR (DLS) 8	3000 LARGE T&R	Yes	SN	Level-1-260C-UNLIM	-40 to 125	1XP
TPS628523HAWDLRQ1	Active	Production	WSON-HR (DLS) 8	3000 LARGE T&R	Yes	SN	Level-1-260C-UNLIM	-40 to 125	1U5
TPS628523PADLSRQ1	Active	Production	WSON-HR (DLS) 8	3000 LARGE T&R	Yes	SN	Level-2-260C-1 YEAR	-40 to 125	1W1
TPS628523PAWDLRQ1	Active	Production	WSON-HR (DLS) 8	3000 LARGE T&R	Yes	SN	Level-1-260C-UNLIM	-40 to 125	1W2
TPS628523PDLSRQ1	Active	Production	WSON-HR (DLS) 8	3000 LARGE T&R	Yes	SN	Level-1-260C-UNLIM	-40 to 125	1WF
TPS628523SADLSRQ1	Active	Production	WSON-HR (DLS) 8	3000 LARGE T&R	Yes	SN	Level-1-260C-UNLIM	-40 to 125	1XB
XPS628523HAWDLRQ1	Active	Preproduction	WSON-HR (DLS) 8	3000 LARGE T&R	-	Call TI	Call TI	-40 to 125	
XPS628523HAWDLRQ1.A	Active	Preproduction	WSON-HR (DLS) 8	3000 LARGE T&R	-	Call TI	Call TI	-40 to 125	
XPS628523PAWDLRQ1	Active	Preproduction	WSON-HR (DLS) 8	3000 LARGE T&R	-	Call TI	Call TI	-40 to 125	
XPS628523PAWDLRQ1.A	Active	Preproduction	WSON-HR (DLS) 8	3000 LARGE T&R	-	Call TI	Call TI	-40 to 125	

(1) **Status:** For more details on status, see our [product life cycle](#).

(2) **Material type:** When designated, preproduction parts are prototypes/experimental devices, and are not yet approved or released for full production. Testing and final process, including without limitation quality assurance, reliability performance testing, and/or process qualification, may not yet be complete, and this item is subject to further changes or possible discontinuation. If available for ordering, purchases will be subject to an additional waiver at checkout, and are intended for early internal evaluation purposes only. These items are sold without warranties of any kind.

(3) **RoHS values:** Yes, No, RoHS Exempt. See the [TI RoHS Statement](#) for additional information and value definition.

(4) **Lead finish/Ball material:** Parts may have multiple material finish options. Finish options are separated by a vertical ruled line. Lead finish/Ball material values may wrap to two lines if the finish value exceeds the maximum column width.

(5) **MSL rating/Peak reflow:** The moisture sensitivity level ratings and peak solder (reflow) temperatures. In the event that a part has multiple moisture sensitivity ratings, only the lowest level per JEDEC standards is shown. Refer to the shipping label for the actual reflow temperature that will be used to mount the part to the printed circuit board.

(6) **Part marking:** There may be an additional marking, which relates to the logo, the lot trace code information, or the environmental category of the part.

Multiple part markings will be inside parentheses. Only one part marking contained in parentheses and separated by a "-" will appear on a part. If a line is indented then it is a continuation of the previous line and the two combined represent the entire part marking for that device.

Important Information and Disclaimer: The information provided on this page represents TI's knowledge and belief as of the date that it is provided. TI bases its knowledge and belief on information provided by third parties, and makes no representation or warranty as to the accuracy of such information. Efforts are underway to better integrate information from third parties. TI has taken and continues to take reasonable steps to provide representative and accurate information but may not have conducted destructive testing or chemical analysis on incoming materials and chemicals. TI and TI suppliers consider certain information to be proprietary, and thus CAS numbers and other limited information may not be available for release.

In no event shall TI's liability arising out of such information exceed the total purchase price of the TI part(s) at issue in this document sold by TI to Customer on an annual basis.

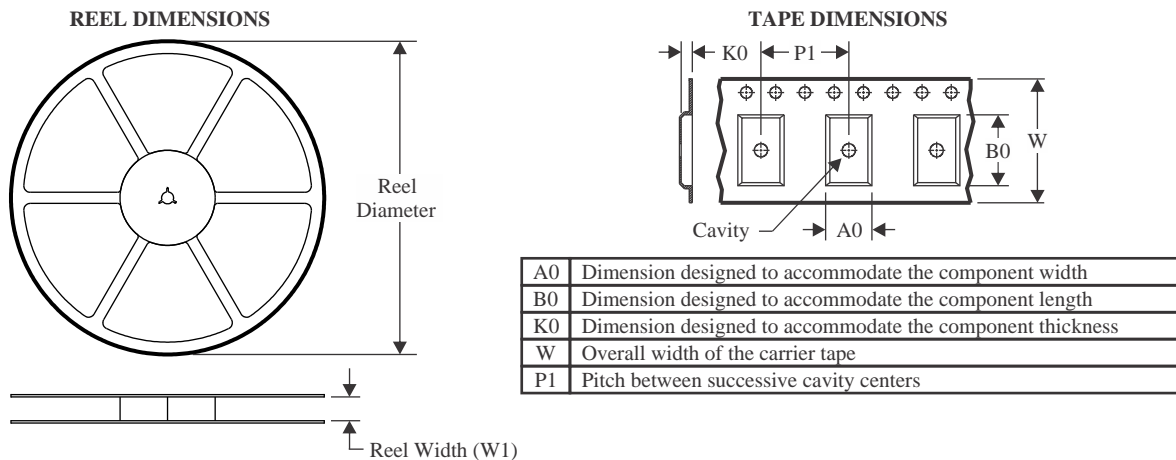
TAPE AND REEL INFORMATION

QUADRANT ASSIGNMENTS FOR PIN 1 ORIENTATION IN TAPE

*All dimensions are nominal

Device	Package Type	Package Drawing	Pins	SPQ	Reel Diameter (mm)	Reel Width W1 (mm)	A0 (mm)	B0 (mm)	K0 (mm)	P1 (mm)	W (mm)	Pin1 Quadrant
TPS628522HADLSRQ1	WSO-N-HR	DLS	8	3000	180.0	8.4	1.75	2.25	1.0	4.0	8.0	Q1
TPS628522SADLSRQ1	WSO-N-HR	DLS	8	3000	180.0	8.4	1.75	2.25	1.0	4.0	8.0	Q1
TPS628523HADLSRQ1	WSO-N-HR	DLS	8	3000	180.0	8.4	1.75	2.25	1.0	4.0	8.0	Q1
TPS628523HAWDLSRQ1	WSO-N-HR	DLS	8	3000	180.0	8.4	1.75	2.25	1.0	4.0	8.0	Q1
TPS628523PADLSRQ1	WSO-N-HR	DLS	8	3000	180.0	8.4	1.75	2.25	1.0	4.0	8.0	Q1
TPS628523PAWDLSRQ1	WSO-N-HR	DLS	8	3000	180.0	8.4	1.75	2.25	1.0	4.0	8.0	Q1
TPS628523PDLSRQ1	WSO-N-HR	DLS	8	3000	180.0	8.4	1.75	2.25	1.0	4.0	8.0	Q1
TPS628523SADLSRQ1	WSO-N-HR	DLS	8	3000	180.0	8.4	1.75	2.25	1.0	4.0	8.0	Q1

TAPE AND REEL BOX DIMENSIONS

*All dimensions are nominal

Device	Package Type	Package Drawing	Pins	SPQ	Length (mm)	Width (mm)	Height (mm)
TPS628522HADLSRQ1	WSO-N-HR	DLS	8	3000	210.0	185.0	35.0
TPS628522SADLSRQ1	WSO-N-HR	DLS	8	3000	210.0	185.0	35.0
TPS628523HADLSRQ1	WSO-N-HR	DLS	8	3000	210.0	185.0	35.0
TPS628523HAWDLSRQ1	WSO-N-HR	DLS	8	3000	210.0	185.0	35.0
TPS628523PADLSRQ1	WSO-N-HR	DLS	8	3000	210.0	185.0	35.0
TPS628523PAWDLSRQ1	WSO-N-HR	DLS	8	3000	210.0	185.0	35.0
TPS628523PDLSRQ1	WSO-N-HR	DLS	8	3000	210.0	185.0	35.0
TPS628523SADLSRQ1	WSO-N-HR	DLS	8	3000	210.0	185.0	35.0

IMPORTANT NOTICE AND DISCLAIMER

TI PROVIDES TECHNICAL AND RELIABILITY DATA (INCLUDING DATASHEETS), DESIGN RESOURCES (INCLUDING REFERENCE DESIGNS), APPLICATION OR OTHER DESIGN ADVICE, WEB TOOLS, SAFETY INFORMATION, AND OTHER RESOURCES "AS IS" AND WITH ALL FAULTS, AND DISCLAIMS ALL WARRANTIES, EXPRESS AND IMPLIED, INCLUDING WITHOUT LIMITATION ANY IMPLIED WARRANTIES OF MERCHANTABILITY, FITNESS FOR A PARTICULAR PURPOSE OR NON-INFRINGEMENT OF THIRD PARTY INTELLECTUAL PROPERTY RIGHTS.

These resources are intended for skilled developers designing with TI products. You are solely responsible for (1) selecting the appropriate TI products for your application, (2) designing, validating and testing your application, and (3) ensuring your application meets applicable standards, and any other safety, security, regulatory or other requirements.

These resources are subject to change without notice. TI grants you permission to use these resources only for development of an application that uses the TI products described in the resource. Other reproduction and display of these resources is prohibited. No license is granted to any other TI intellectual property right or to any third party intellectual property right. TI disclaims responsibility for, and you fully indemnify TI and its representatives against any claims, damages, costs, losses, and liabilities arising out of your use of these resources.

TI's products are provided subject to [TI's Terms of Sale](#), [TI's General Quality Guidelines](#), or other applicable terms available either on ti.com or provided in conjunction with such TI products. TI's provision of these resources does not expand or otherwise alter TI's applicable warranties or warranty disclaimers for TI products. Unless TI explicitly designates a product as custom or customer-specified, TI products are standard, catalog, general purpose devices.

TI objects to and rejects any additional or different terms you may propose.

Copyright © 2026, Texas Instruments Incorporated

Last updated 10/2025