

TS3A5017 Dual SP4T Analog Switch / Multiplexer / Demultiplexer

1 Features

- Isolation in the Powered-Down Mode, $V_+ = 0$
- Low ON-State Resistance
- Low Charge Injection
- Excellent ON-State Resistance Matching
- Low Total Harmonic Distortion (THD)
- 2.3-V to 3.6-V Single-Supply Operation
- Latch-Up Performance Exceeds 100 mA Per JESD 78, Class II
- ESD Performance Tested Per JESD 22
 - 1500-V Human-Body Model (A114-B, Class II)
 - 1000-V Charged-Device Model (C101)

2 Applications

- Sample-and-Hold Circuits
- Battery-Powered Equipment
- Audio and Video Signal Routing
- Communication Circuits

3 Description

The TS3A5017 device is a dual single-pole quadruple-throw (4:1) analog switch that is designed to operate from 2.3 V to 3.6 V. This device can handle both digital and analog signals, and signals up to V_+ can be transmitted in either direction.

Device Information⁽¹⁾

PART NUMBER	PACKAGE	BODY SIZE (NOM)
TS3A5017	SOIC (16)	9.90 mm × 3.90 mm
	SSOP (16)	4.90 mm × 3.90 mm
	TSSOP (16)	5.00 mm × 4.40 mm
	TVSOP (16)	4.40 mm × 3.60 mm
	UQFN (16)	2.50 mm × 1.80 mm
	VQFN (16)	4.00 mm × 3.50 mm

(1) For all available packages, see the orderable addendum at the end of the data sheet.

Block Diagram

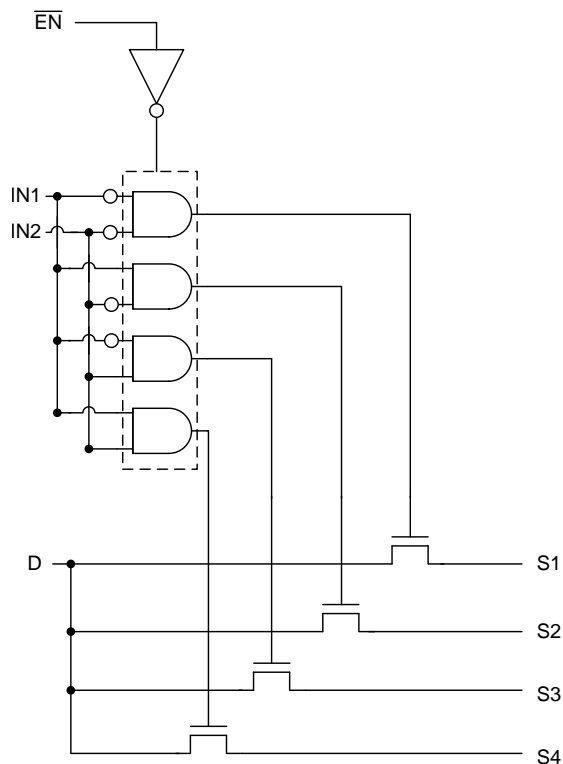

Table of Contents

1 Features	1	8.2 Functional Block Diagram	14
2 Applications	1	8.3 Feature Description	14
3 Description	1	8.4 Device Functional Modes	15
4 Revision History	2	9 Application and Implementation	16
5 Pin Configuration and Functions	3	9.1 Application Information	16
6 Specifications	4	9.2 Typical Application	16
6.1 Absolute Maximum Ratings	4	10 Power Supply Recommendations	17
6.2 ESD Ratings	4	11 Layout	17
6.3 Recommended Operating Conditions	4	11.1 Layout Guidelines	17
6.4 Thermal Information	4	11.2 Layout Example	18
6.5 Electrical Characteristics for 3.3-V Supply	5	12 Device and Documentation Support	19
6.6 Electrical Characteristics for 2.5-V Supply	6	12.1 Device Support	19
6.7 Switching Characteristics for 3.3-V supply	7	12.2 Documentation Support	20
6.8 Switching Characteristics for 2.5-V supply	7	12.3 Trademarks	20
6.9 Typical Characteristics	8	12.4 Electrostatic Discharge Caution	20
7 Parameter Measurement Information	10	12.5 Glossary	20
8 Detailed Description	14	13 Mechanical, Packaging, and Orderable Information	21
8.1 Overview	14		

4 Revision History

Changes from Revision F (October 2018) to Revision G	Page
• Changed <i>Feature</i> From: 2000-V Human-Body Model To: 1500-V Human-Body Model	1
• Changed the HBM value From: ± 2000 V To: ± 1500 V in the <i>ESD Ratings</i>	4

Changes from Revision E (April 2015) to Revision F	Page
• Changed the X_{TALK} MAX value From: -49 dB To -69 dB in the <i>Electrical Characteristics for 3.3-V Supply</i>	6

Changes from Revision D (December 2008) to Revision E	Page
• Added <i>Applications</i> , <i>Device Information</i> table, <i>Pin Functions</i> table, <i>ESD Ratings</i> table, <i>Thermal Information</i> table, <i>Typical Characteristics</i> , <i>Feature Description</i> section, <i>Device Functional Modes</i> , <i>Application and Implementation</i> section, <i>Power Supply Recommendations</i> section, <i>Layout</i> section, <i>Device and Documentation Support</i> section, and <i>Mechanical, Packaging, and Orderable Information</i> section.	1
• Deleted <i>Ordering Information</i> table.	1

5 Pin Configuration and Functions

**D, DBQ, DGV, and PW Package
16-Pin SOIC, SSOP, TVSOP and TSSOP
(Top View)**

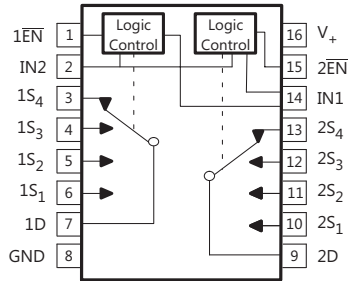

**RGY Package
16-Pin VQFN
(Top View)**

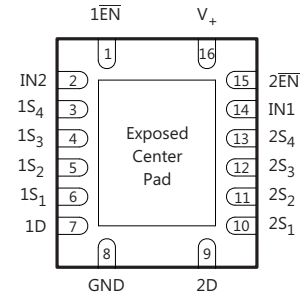

If exposed center pad is used, it must be connected as a secondary ground or left electrically open.

**RSV Package
16-Pin VQFN
(Top View)**

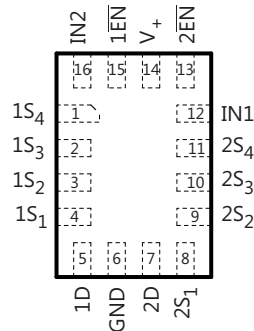

Pin Functions

NAME	PIN		TYPE	DESCRIPTION
	SOIC, SSOP, TVSOP, TSSOP, VQFN NO.	UQFN NO.		
1D	7	5	I/O	Common path for switch 1
1EN	1	15	I	Active-low enable for switch 1
1S1	6	4	I/O	Switch 1 channel 1
1S2	5	3	I/O	Switch 1 channel 2
1S3	4	2	I/O	Switch 1 channel 3
1S4	3	1	I/O	Switch 1 channel 4
2D	9	7	I/O	Common path for switch 2
2EN	15	13	I	Active-low enable for switch 2
2S1	10	8	I/O	Switch 2 channel 1
2S2	11	9	I/O	Switch 2 channel 2
2S3	12	10	I/O	Switch 2 channel 3
2S4	13	11	I/O	Switch 2 channel 4
GND	8	6	–	Ground
IN1	14	12	I	Switch 1 input select
IN2	2	16	I	Switch 2 input select
V+	16	14	–	Supply voltage

6 Specifications

6.1 Absolute Maximum Ratings

 over operating free-air temperature range (unless otherwise noted)⁽¹⁾⁽²⁾

		MIN	MAX	UNIT
V ₊	Supply voltage ⁽³⁾	-0.5	4.6	V
V _S , V _D	Analog voltage ⁽³⁾⁽⁴⁾	-0.5	4.6	V
I _{SK} , I _{DK}	Analog port clamp current	V _S , V _D < 0		mA
I _S , I _D	ON-state switch current	V _S , V _D = 0 to 7 V		mA
V _I	Digital input voltage	-0.5	4.6	V
I _{IK}	Digital input clamp current ⁽³⁾⁽⁴⁾	V _I < 0		mA
I ₊	Continuous current through V ₊		100	mA
I _{GND}	Continuous current through GND	-100		mA
T _{stg}	Storage temperature	-65	150	°C

- Stresses beyond those listed under *Absolute Maximum Ratings* may cause permanent damage to the device. These are stress ratings only, and functional operation of the device at these or any other conditions beyond those indicated under *Recommended Operating Conditions* is not implied. Exposure to absolute-maximum-rated conditions for extended periods may affect device reliability.
- The algebraic convention, whereby the most negative value is a minimum and the most positive value is a maximum.
- All voltages are with respect to ground, unless otherwise specified.
- The input and output voltage ratings may be exceeded if the input and output clamp-current ratings are observed.

6.2 ESD Ratings

		VALUE	UNIT
V _(ESD)	Electrostatic discharge	Human-body model (HBM), per ANSI/ESDA/JEDEC JS-001 ⁽¹⁾	V
		Charged-device model (CDM), per JEDEC specification JESD22-C101 ⁽²⁾	

- JEDEC document JEP155 states that 500-V HBM allows safe manufacturing with a standard ESD control process.
- JEDEC document JEP157 states that 250-V CDM allows safe manufacturing with a standard ESD control process.

6.3 Recommended Operating Conditions

over operating free-air temperature range (unless otherwise noted)

		MIN	MAX	UNIT
V _{I/O}	Switch input/output voltage range	0	3.6	V
V ₊	Supply voltage range	2.3	3.6	V
V _I	Control input voltage range	0	3.6	V
T _A	Operating Temperature Range	-40	85	°C

6.4 Thermal Information

THERMAL METRIC ⁽¹⁾	TS3A5018						UNIT	
	D (SOIC)	DBQ (SSOP)	DGV (TVSOP)	PW (TSSOP)	RGY (VQFN)	RSV (UQFN)		
	16 PINS	16 PINS	16 PINS	16 PINS	16 PINS	16 PINS		
R _{θJA}	Junction-to-ambient thermal resistance	73	82	120	108	91.6	184	°C/W

- For more information about traditional and new thermal metrics, see the *IC Package Thermal Metrics* application report, [SPRA953](#).

6.5 Electrical Characteristics for 3.3-V Supply

 $V_+ = 2.7\text{ V to }3.6\text{ V}$, $T_A = -40^\circ\text{C to }85^\circ\text{C}$ (unless otherwise noted)⁽¹⁾

PARAMETER		TEST CONDITIONS		T_A	V_+	MIN	TYP	MAX	UNIT
Analog Switch									
V_D, V_S	Analog signal range					0		V_+	V
r_{on}	ON-state resistance	$0 \leq V_S \leq V_+$, $I_D = -32\text{ mA}$,	Switch ON, see Figure 12	25°C	3 V		11	12	Ω
				Full			14		
Δr_{on}	ON-state resistance match between channels	$V_S = 2.1\text{ V}$, $I_D = -32\text{ mA}$,	Switch ON, see Figure 12	25°C	3 V		1	2	Ω
				Full			3		
$r_{on(Flat)}$	ON-state resistance flatness	$0 \leq V_S \leq V_+$, $I_D = -32\text{ mA}$,	Switch ON, see Figure 12	25°C	3 V		7	9	Ω
				Full			10		
$I_{S(OFF)}$	S OFF leakage current	$V_S = 1\text{ V}, V_D = 3\text{ V}$, or $V_S = 3\text{ V}, V_D = 1\text{ V}$,	Switch OFF, see Figure 13	25°C	3.6 V	-0.1	0.05	0.1	μA
				Full		-0.2		0.2	
$I_{SPWR(OFF)}$		$V_S = 0\text{ to }3.6\text{ V}$, $V_D = 3.6\text{ V to }0$,		25°C	0 V	-1	0.5	1	μA
				Full		-5		5	
$I_{D(OFF)}$	D OFF leakage current	$V_S = 1\text{ V}, V_D = 3\text{ V}$, or $V_S = 3\text{ V}, V_D = 1\text{ V}$,	Switch OFF, see Figure 13	25°C	3.6 V	-0.1	0.05	0.1	μA
				Full		-0.2		0.2	
$I_{DPWR(OFF)}$		$V_D = 0\text{ to }3.6\text{ V}$, $V_S = 3.6\text{ V to }0$,		25°C	0 V	-1	0.5	1	μA
				Full		-5		5	
$I_{S(ON)}$	S ON leakage current	$V_S = 1\text{ V}, V_D = \text{Open}$, or $V_S = 3\text{ V}, V_D = \text{Open}$,	Switch ON, see Figure 14	25°C	3.6 V	-0.1	0.05	0.1	μA
				Full		-0.2		0.2	
$I_{D(ON)}$	D ON leakage current	$V_D = 1\text{ V}, V_S = \text{Open}$, or $V_D = 3\text{ V}, V_S = \text{Open}$,	Switch ON, see Figure 14	25°C	3.6 V	-0.1	0.05	0.1	μA
				Full		-0.2		0.2	
Digital Control Inputs (IN1, IN2, EN)⁽²⁾									
V_{IH}	Input logic high			Full		2		V_+	V
V_{IL}	Input logic low			Full		0		0.8	V
I_{IH}, I_{IL}	Input leakage current	$V_I = V_+$ or 0		25°C	3.6 V	-1	0.05	1	μA
				Full		-1		1	
Q_C	Charge injection	$V_{GEN} = 0, R_{GEN} = 0$, $C_L = 0.1\text{ nF}$,	See Figure 21	25°C	3.3 V		5		pC
$C_{S(OFF)}$	S OFF capacitance	$V_S = V_+$ or GND, Switch OFF,	See Figure 15	25°C	3.3 V		4.5		pF
$C_{D(OFF)}$	D OFF capacitance	$V_D = V_+$ or GND, Switch OFF,	See Figure 15	25°C	3.3 V		19		pF
$C_{S(ON)}$	S ON capacitance	$V_S = V_+$ or GND, Switch ON,	See Figure 15	25°C	3.3 V		25		pF
$C_{D(ON)}$	D ON capacitance	$V_D = V_+$ or GND, Switch ON,	See Figure 15	25°C	3.3 V		25		pF
C_I	Digital input capacitance	$V_I = V_+$ or GND,	See Figure 15	25°C	3.3 V		2		pF
BW	Bandwidth	$R_L = 50\ \Omega$, Switch ON,	See Figure 17	25°C	3.3 V		165		MHz
O_{ISO}	OFF isolation	$R_L = 50\ \Omega$, $f = 1\text{ MHz}$,	See Figure 18	25°C	3.3 V		-69		dB

(1) The algebraic convention, whereby the most negative value is a minimum and the most positive value is a maximum

(2) All unused digital inputs of the device must be held at V_+ or GND to ensure proper device operation. Refer to the TI application report, *Implications of Slow or Floating CMOS Inputs*, literature number SCBA004.

Electrical Characteristics for 3.3-V Supply (continued)
 $V_+ = 2.7\text{ V to }3.6\text{ V}$, $T_A = -40^\circ\text{C to }85^\circ\text{C}$ (unless otherwise noted)⁽¹⁾

PARAMETER		TEST CONDITIONS		T_A	V_+	MIN	TYP	MAX	UNIT
X_{TALK}	Crosstalk	$R_L = 50\ \Omega$, $f = 1\ \text{MHz}$,	See Figure 19	25°C	3.3 V		-69		dB
$X_{\text{TALK(ADJ)}}$	Crosstalk adjacent	$R_L = 50\ \Omega$, $f = 1\ \text{MHz}$,	See Figure 20	25°C	3.3 V		-74		dB
THD	Total harmonic distortion	$R_L = 600\ \Omega$, $C_L = 50\ \text{pF}$,	$f = 20\ \text{Hz to }20\ \text{kHz}$, see Figure 22	25°C	3.3 V		0.21%		
Supply									
I_+	Positive supply current	$V_I = V_+$ or GND,	Switch ON or OFF	25°C	3.6 V		2.5	7	μA
				Full				10	

6.6 Electrical Characteristics for 2.5-V Supply
 $V_+ = 2.3\text{ V to }2.7\text{ V}$, $T_A = -40^\circ\text{C to }85^\circ\text{C}$ (unless otherwise noted)⁽¹⁾

PARAMETER		TEST CONDITIONS		T_A	V_+	MIN	TYP	MAX	UNIT
Analog Switch									
V_D, V_S	Analog signal range					0		V_+	V
r_{on}	ON-state resistance	$0 \leq V_S \leq V_+$, $I_D = -24\ \text{mA}$,	Switch ON, see Figure 12	25°C	2.3 V		20.5	22	Ω
				Full				24	
Δr_{on}	ON-state resistance match between channels	$V_S = 1.6\ \text{V}$, $I_D = -24\ \text{mA}$,	Switch ON, see Figure 12	25°C	2.3 V		1	2	Ω
				Full				3	
$r_{\text{on(flat)}}$	ON-state resistance flatness	$0 \leq V_S \leq V_+$, $I_D = -24\ \text{mA}$,	Switch ON, see Figure 12	25°C	2.3 V		16	18	Ω
				Full				20	
$I_{\text{S(OFF)}}$	S OFF leakage current	$V_S = 0.5\ \text{V}$, $V_D = 2.2\ \text{V}$, or $V_S = 2.2\ \text{V}$, $V_D = 0.5\ \text{V}$,	Switch OFF, see Figure 13	25°C	2.7 V	-0.1	0.05	0.1	μA
$I_{\text{SPWR(OFF)}}$		$V_S = 0\ \text{to }2.7\ \text{V}$, $V_D = 2.7\ \text{V to }0$,		Full		0 V	-1	0.5	
$I_{\text{D(OFF)}}$	D OFF leakage current	$V_S = 0.5\ \text{V}$, $V_D = 2.2\ \text{V}$, or $V_S = 2.2\ \text{V}$, $V_D = 0.5\ \text{V}$,	Switch OFF, see Figure 13	25°C	2.7 V	-0.1	0.05	0.1	μA
$I_{\text{DPWR(OFF)}}$		$V_D = 0\ \text{to }2.7\ \text{V}$, $V_S = 2.7\ \text{V to }0$,		Full		0 V	-0.2		
$I_{\text{S(ON)}}$	S ON leakage current	$V_S = 0.5\ \text{V}$, $V_D = \text{Open}$, or $V_S = 2.2\ \text{V}$, $V_D = \text{Open}$,	Switch ON, see Figure 14	25°C	2.7 V	-0.1	0.05	0.1	μA
$I_{\text{D(ON)}}$	D ON leakage current	$V_D = 0.5\ \text{V}$, $V_S = \text{Open}$, or $V_D = 2.2\ \text{V}$, $V_S = \text{Open}$,	Switch ON, see Figure 14	Full		2.7 V	-0.2		
Digital Control Inputs (IN1, IN2, EN)⁽²⁾									
V_{IH}	Input logic high			Full		1.7		V_+	V
V_{IL}	Input logic low			Full		0		0.7	V
$I_{\text{IH}}, I_{\text{IL}}$	Input leakage current	$V_I = V_+$ or 0		25°C	2.7 V	-1	0.05	1	μA
				Full				-1	
Q_C	Charge injection	$V_{\text{GEN}} = 0$, $R_{\text{GEN}} = 0$, $C_L = 0.1\ \text{nF}$,	See Figure 21	25°C	2.5 V				pC
$C_{\text{S(OFF)}}$	S OFF capacitance	$V_S = V_+$ or GND, Switch OFF,	See Figure 15	25°C	2.5 V		4.5		pF

(1) The algebraic convention, whereby the most negative value is a minimum and the most positive value is a maximum

(2) All unused digital inputs of the device must be held at V_+ or GND to ensure proper device operation. Refer to the TI application report, *Implications of Slow or Floating CMOS Inputs*, literature number SCBA004.

Electrical Characteristics for 2.5-V Supply (continued)

 $V_+ = 2.3\text{ V to } 2.7\text{ V}$, $T_A = -40^\circ\text{C to } 85^\circ\text{C}$ (unless otherwise noted)⁽¹⁾

PARAMETER		TEST CONDITIONS		T_A	V_+	MIN	TYP	MAX	UNIT
$C_{D(OFF)}$	D OFF capacitance	$V_D = V_+$ or GND, Switch OFF,	See Figure 15	25°C	2.5 V		18.5		pF
$C_{S(ON)}$	S ON capacitance	$V_S = V_+$ or GND, Switch ON,	See Figure 15	25°C	2.5 V		24		pF
$C_{D(ON)}$	D ON capacitance	$V_D = V_+$ or GND, Switch ON,	See Figure 15	25°C	2.5 V		24		pF
C_I	Digital input capacitance	$V_I = V_+$ or GND,	See Figure 15	25°C	2.5 V		2		pF
BW	Bandwidth	$R_L = 50\ \Omega$, Switch ON,	See Figure 17	25°C	2.5 V		165		MHz
O_{ISO}	OFF isolation	$R_L = 50\ \Omega$, $f = 1\text{ MHz}$,	See Figure 18	25°C	2.5 V		-69		dB
X_{TALK}	Crosstalk	$R_L = 50\ \Omega$, $f = 1\text{ MHz}$,	See Figure 19	25°C	2.5 V		-69		dB
$X_{TALK(ADJ)}$	Crosstalk adjacent	$R_L = 50\ \Omega$, $f = 1\text{ MHz}$,	See Figure 20	25°C	2.5 V		-74		dB
THD	Total harmonic distortion	$R_L = 600\ \Omega$, $C_L = 50\text{ pF}$,	$f = 20\text{ Hz to } 20\text{ kHz}$, see Figure 22	25°C	2.5 V		0.29%		
Supply									
I_+	Positive supply current	$V_I = V_+$ or GND,	Switch ON or OFF	25°C	2.7 V		2.5	7	μA
				Full					

6.7 Switching Characteristics for 3.3-V supply

over operating free-air temperature range (unless otherwise noted)

PARAMETER		TEST CONDITIONS		T_A	V_+	MIN	TYP	MAX	UNIT
t_{ON}	Turnon time	$V_D = 2\text{ V}$, $R_L = 300\ \Omega$,	$C_L = 35\text{ pF}$, see Figure 16	25°C	3.3 V	1	5	9.5	ns
				Full	3 V to 3.6 V	1		10.5	
t_{OFF}	Turnoff time	$V_D = 2\text{ V}$, $R_L = 300\ \Omega$,	$C_L = 35\text{ pF}$, see Figure 16	25°C	3.3 V	0.5	1.5	3.5	ns
				Full	3 V to 3.6 V	0.5		4.5	

6.8 Switching Characteristics for 2.5-V supply

over operating free-air temperature range (unless otherwise noted)

PARAMETER		TEST CONDITIONS		T_A	V_+	MIN	TYP	MAX	UNIT
t_{ON}	Turnon time	$V_{COM} = 2\text{ V}$, $R_L = 300\ \Omega$,	$C_L = 35\text{ pF}$, see Figure 16	25°C	2.5 V	1.5	5	8	ns
				Full	2.3 V to 2.7 V	1		10	
t_{OFF}	Turnoff time	$V_{COM} = 2\text{ V}$, $R_L = 300\ \Omega$,	$C_L = 35\text{ pF}$, see Figure 16	25°C	2.5 V	0.3	2	4.5	ns
				Full	2.3 V to 2.7 V	0.3		6	

6.9 Typical Characteristics

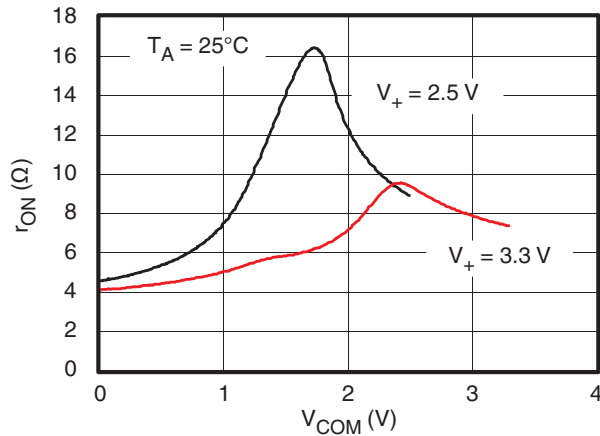

Figure 1. r_{on} vs V_{COM}

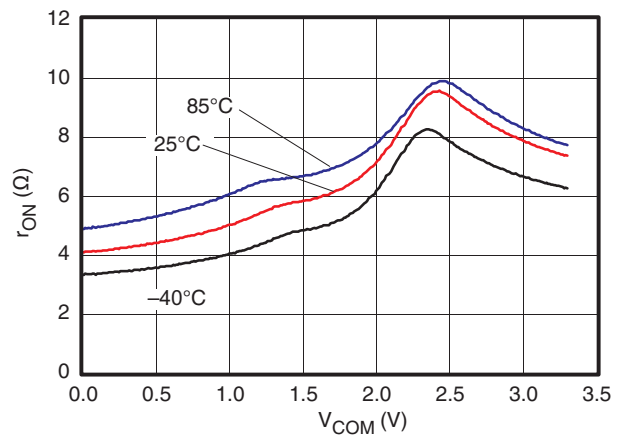

Figure 2. r_{on} vs V_{COM} ($V_+ = 3.3$ V)

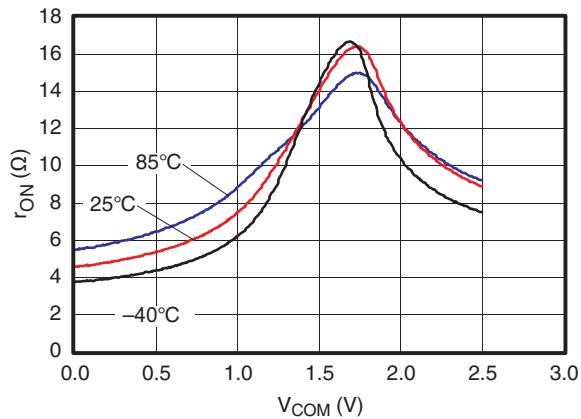

Figure 3. r_{on} vs V_{COM} ($V_+ = 2.5$ V)

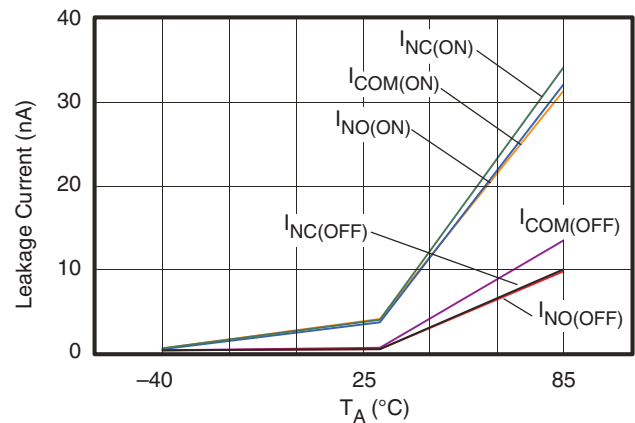

Figure 4. Leakage Current vs Temperature ($V_+ = 3.6$ V)

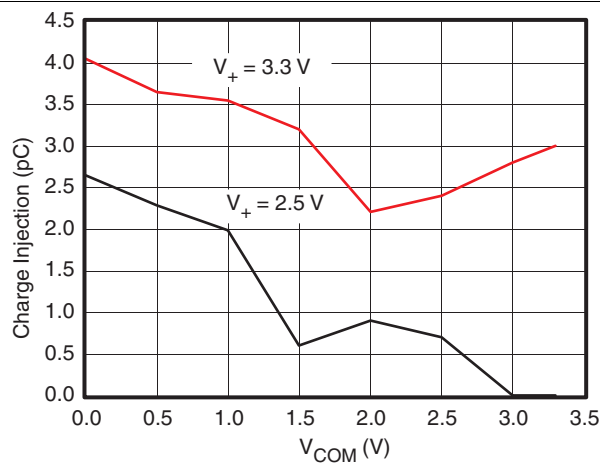

Figure 5. Charge Injection (Q_C) vs V_{COM}

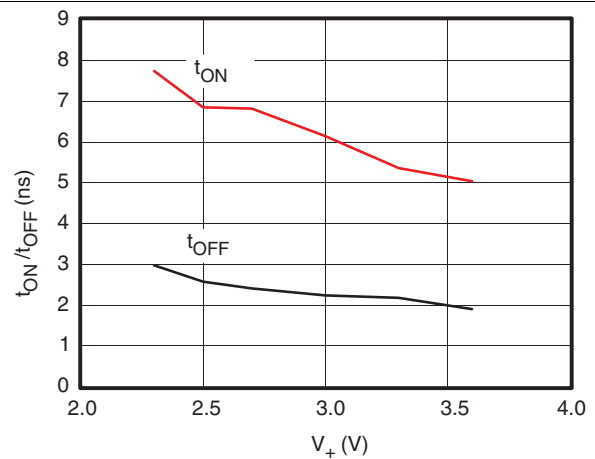

Figure 6. t_{ON} and t_{OFF} vs Supply Voltage

Typical Characteristics (continued)

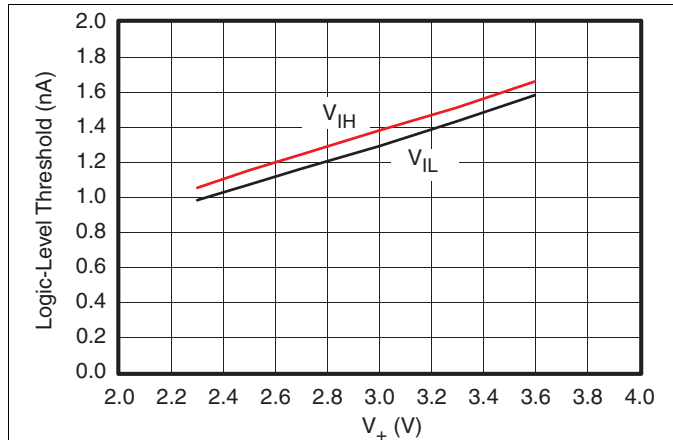

Figure 7. Logic-Level Threshold vs V_+

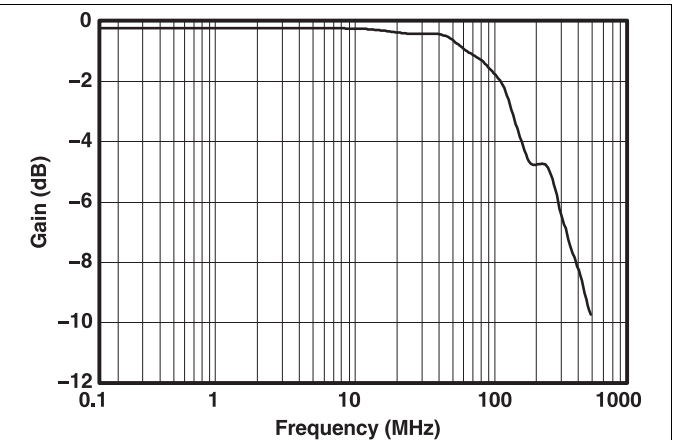

Figure 8. Bandwidth (Gain vs Frequency) ($V_+ = 3.3$ V)

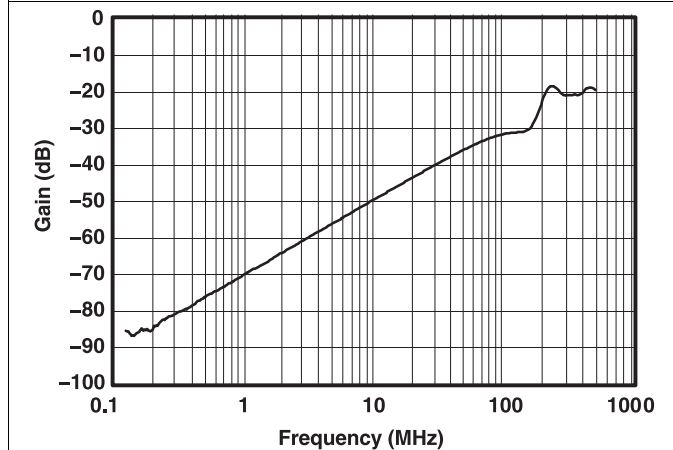

Figure 9. OFF Isolation and Crosstalk vs Frequency ($V_+ = 3.3$ V)

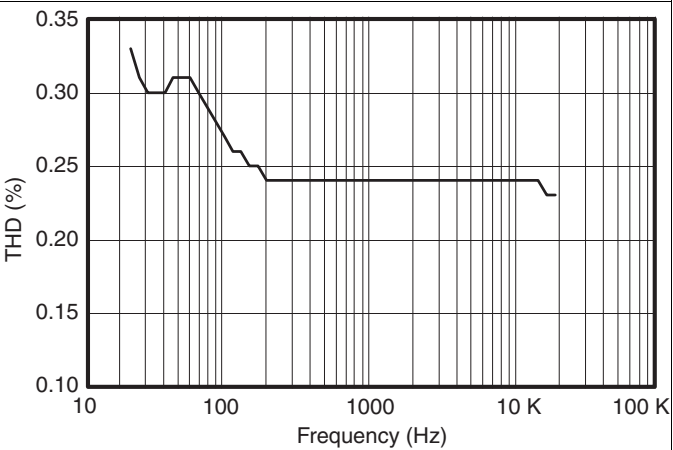

Figure 10. Total Harmonic Distortion vs Frequency

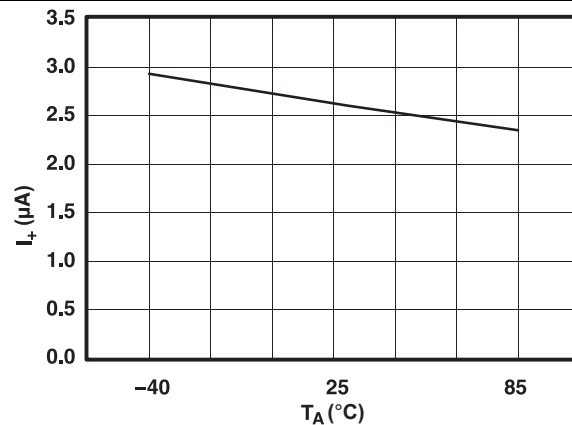

Figure 11. Power-Supply Current vs Temperature ($V_+ = 3.6$ V)

7 Parameter Measurement Information

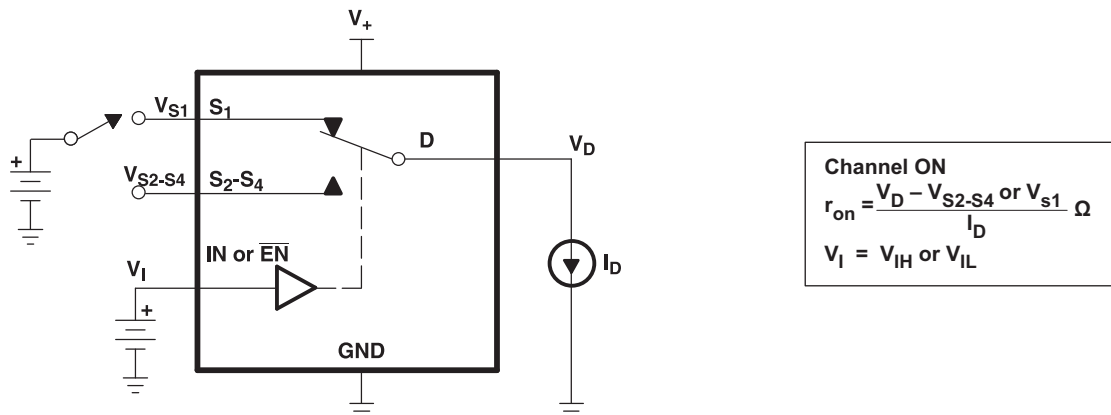

Figure 12. ON-State Resistance (r_{on})

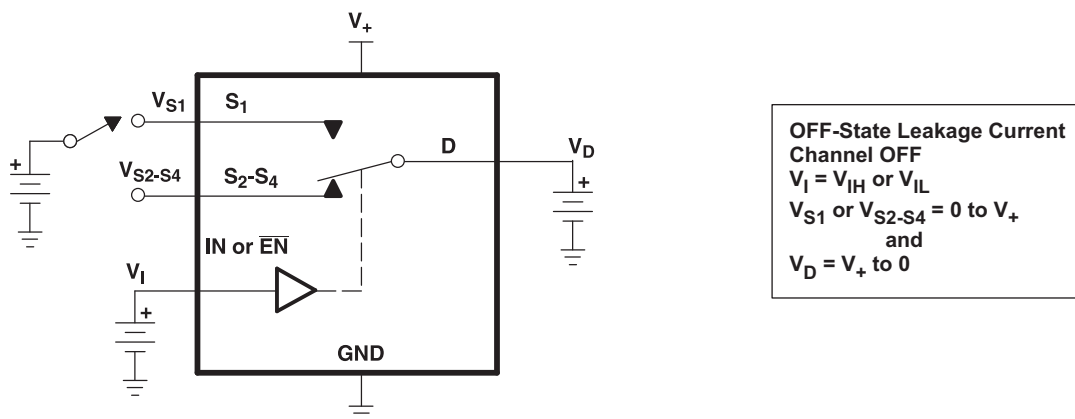

Figure 13. OFF-State Leakage Current ($I_{D(OFF)}$, $I_{S(OFF)}$)

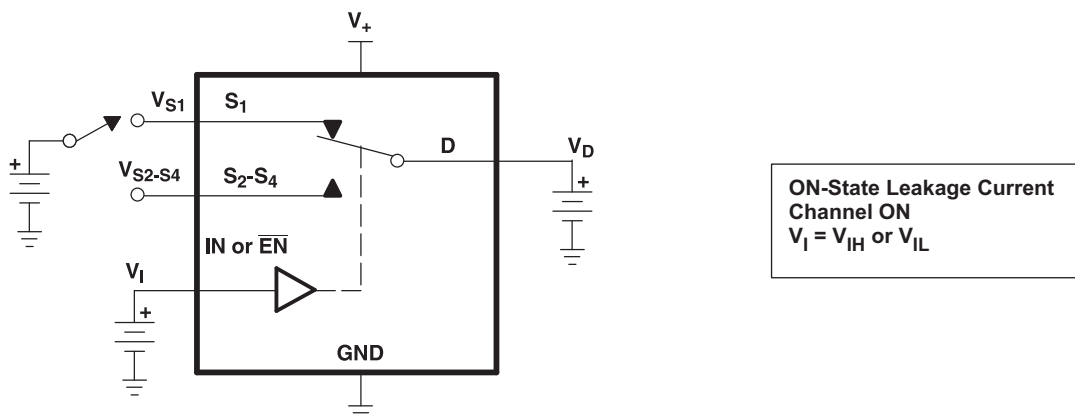

Figure 14. ON-State Leakage Current ($I_{D(ON)}$, $I_{S(ON)}$)

Parameter Measurement Information (continued)

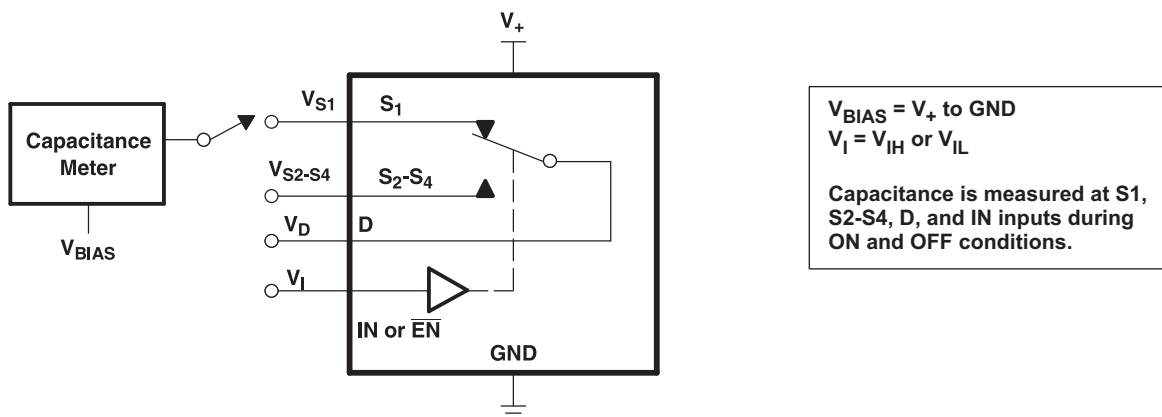
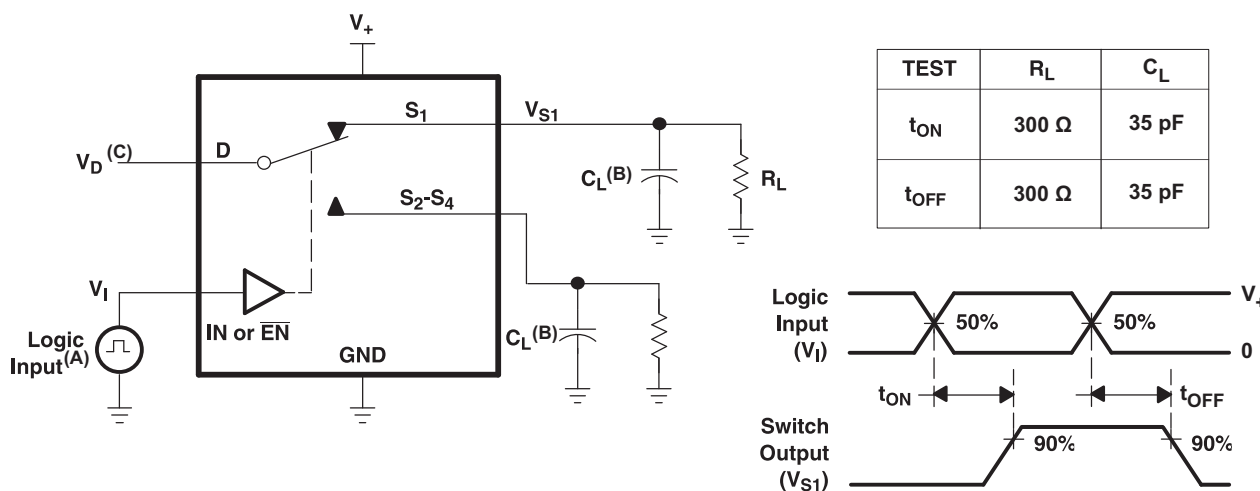

Figure 15. Capacitance (C_I , $C_{D(OFF)}$, $C_{D(ON)}$, $C_{S(OFF)}$, $C_{S(ON)}$)



- A. All input pulses are supplied by generators having the following characteristics: PRR \leq 10 MHz, $Z_O = 50 \Omega$, $t_r < 5$ ns, $t_f < 5$ ns.
- B. C_L includes probe and jig capacitance.
- C. See Electrical Characteristics for V_D .

Figure 16. Turnon (t_{ON}) and Turnoff Time (t_{OFF})

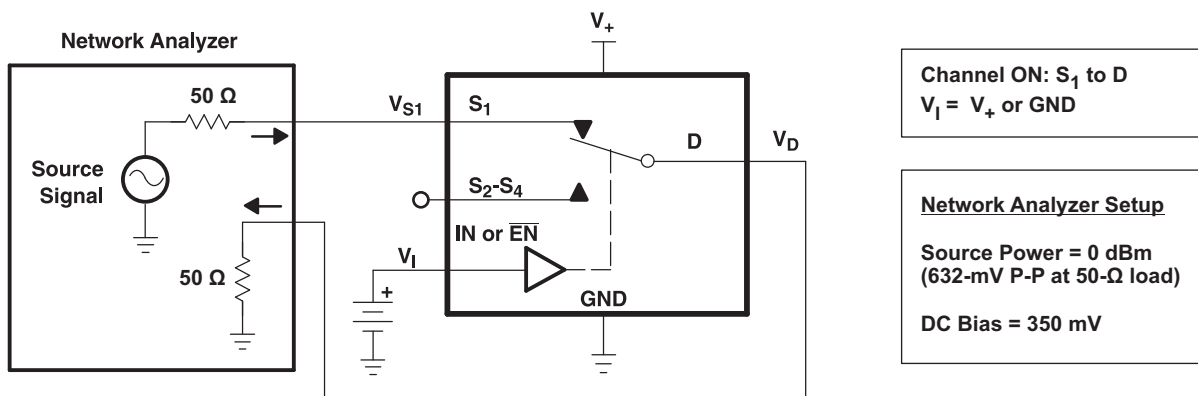
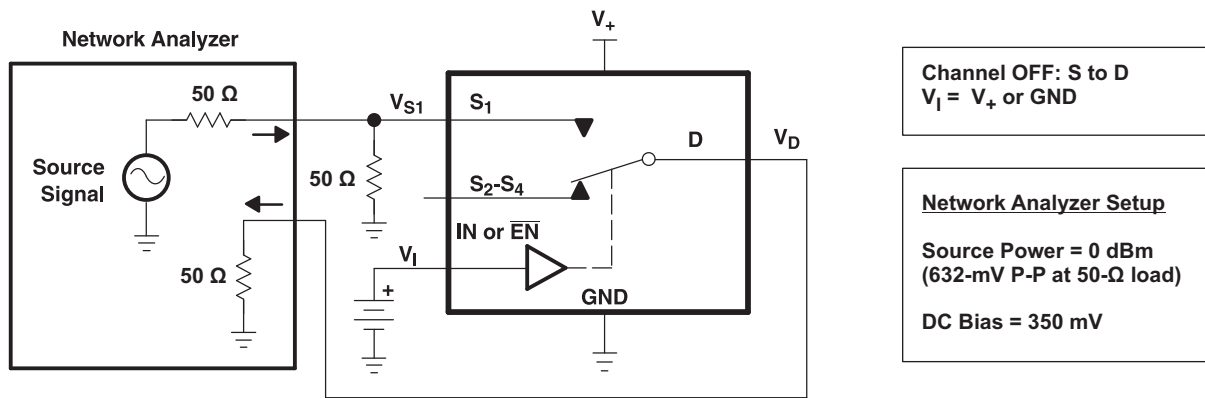
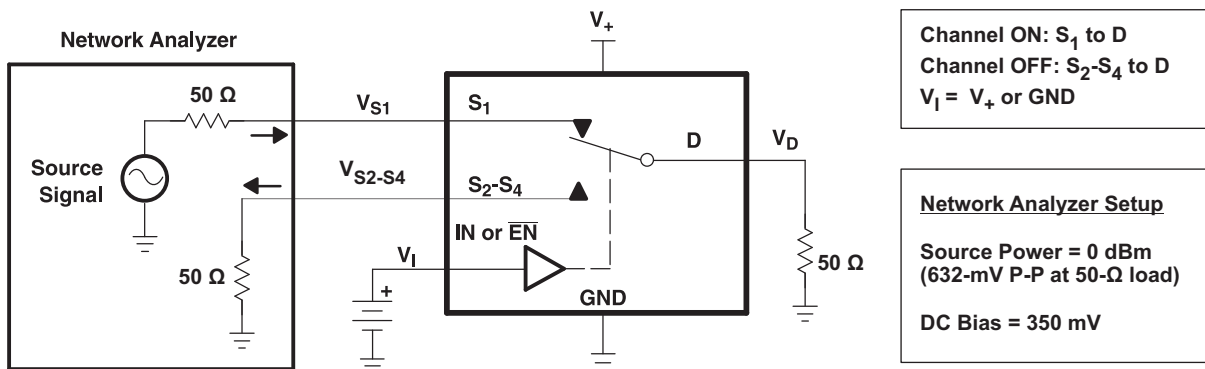
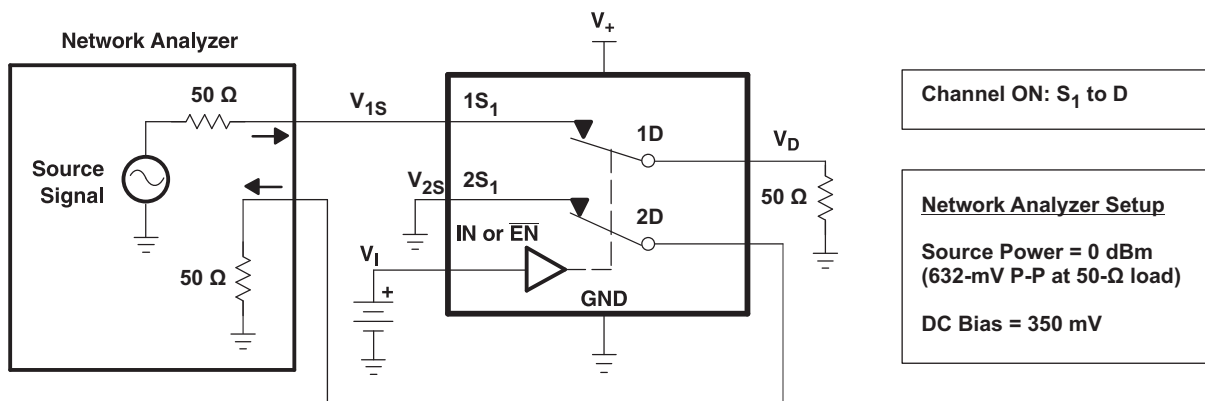
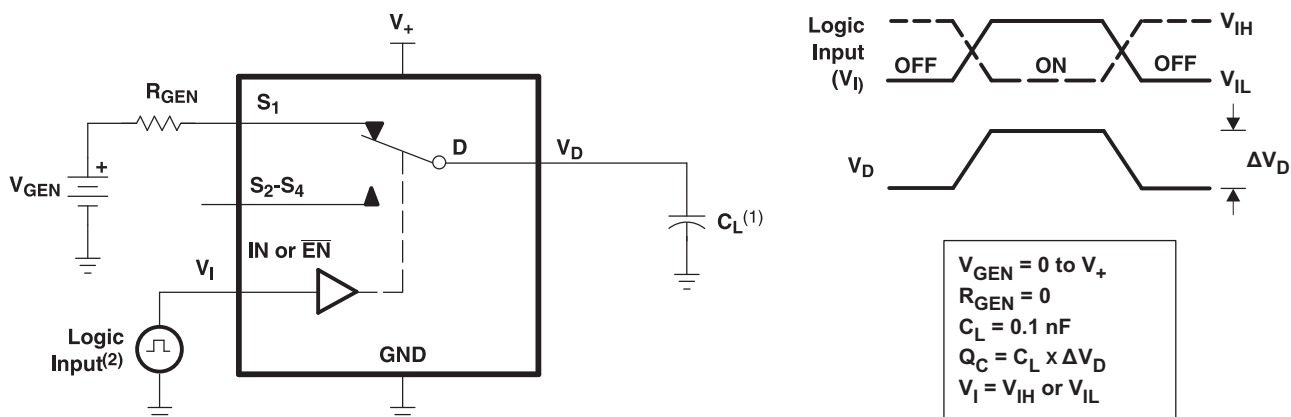

Figure 17. Bandwidth (BW)

Parameter Measurement Information (continued)

Figure 18. OFF Isolation (O_{ISO})

Figure 19. Crosstalk (X_{TALK})

Figure 20. Adjacent Crosstalk (X_{TALK})

Parameter Measurement Information (continued)

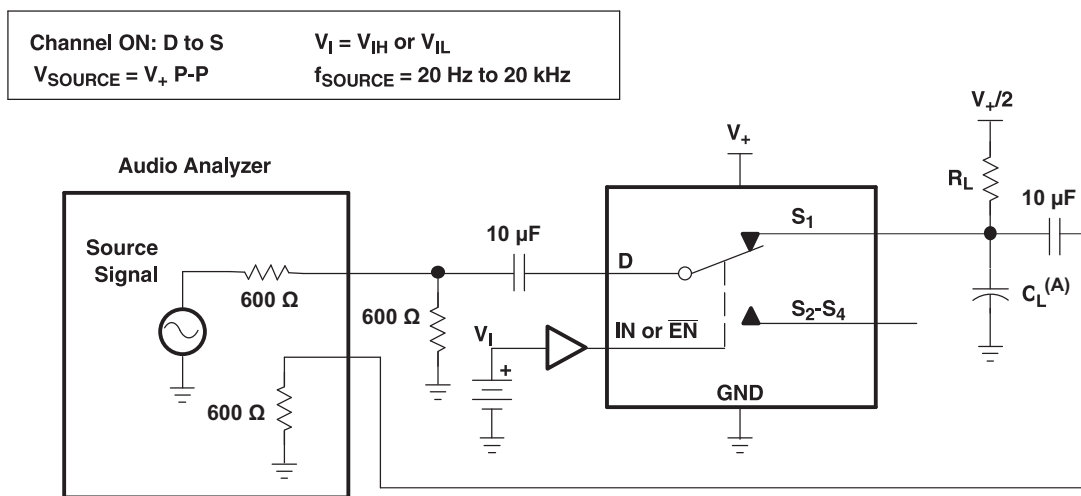

- A. All input pulses are supplied by generators having the following characteristics: PRR ≤ 10 MHz, Z_O = 50 Ω, t_r < 5 ns, t_f < 5 ns.
- B. C_L includes probe and jig capacitance.

Figure 21. Charge Injection (Q_C)



- A. C_L includes probe and jig capacitance.

Figure 22. Total Harmonic Distortion (THD)

8 Detailed Description

8.1 Overview

The TS3A5017 is a dual Single-Pole-4-Throw (SP4T) solid-state analog switch. The TS3A5017, like all analog switches, is bidirectional. Each D pin connects to its four respective S pins, with the switch connection dependent on the status of $\overline{\text{EN}}$, IN2, and IN1. See [Table 1](#) for the switch configuration truth table.

8.2 Functional Block Diagram

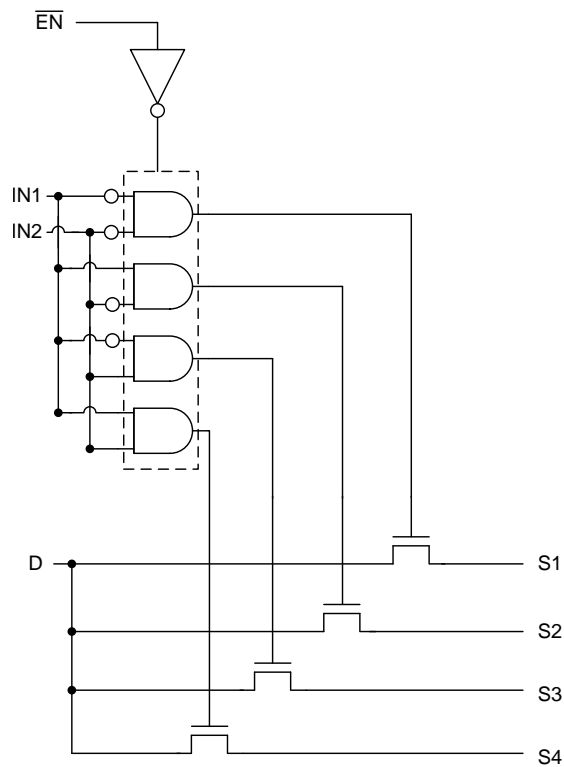

Figure 23. Functional Block Diagram (Each Switch)

8.3 Feature Description

Isolation in powered-down mode allows signals to be present at the inputs while the switch is powered off without causing damage to the device. The low ON-state resistance and low charge injection give the TS3A5017 better performance at higher speeds.

8.4 Device Functional Modes

Table 1. Function Table

$\overline{\text{EN}}$	IN2	IN1	D TO S, S TO D
L	L	L	D = S ₁
L	L	H	D = S ₂
L	H	L	D = S ₃
L	H	H	D = S ₄
H	X	X	OFF

9 Application and Implementation

NOTE

Information in the following applications sections is not part of the TI component specification, and TI does not warrant its accuracy or completeness. TI's customers are responsible for determining suitability of components for their purposes. Customers should validate and test their design implementation to confirm system functionality.

9.1 Application Information

The TS3A5018 can be used in a variety of customer systems. The TS3A5018 can be used anywhere multiple analog or digital signals must be selected to pass across a single line.

9.2 Typical Application

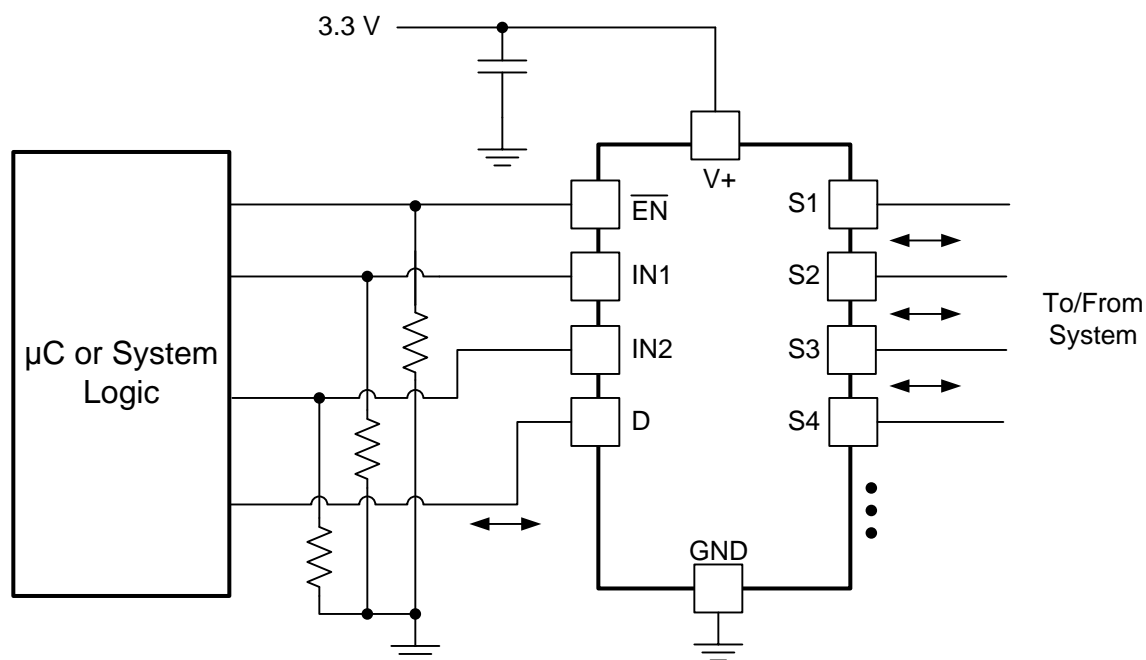

Figure 24. System Schematic for TS3A5017

9.2.1 Design Requirements

In this particular application, V+ was 3.3 V, although V+ is allowed to be any voltage specified in [Recommended Operating Conditions](#). A decoupling capacitor is recommended on the V+ pin. See [Power Supply Recommendations](#) for more details.

9.2.2 Detailed Design Procedure

In this application, $\overline{\text{EN}}$, IN1, and IN2 are, by default, pulled low to GND. Choose these resistor sizes based on the current driving strength of the GPIO, the desired power consumption, and the switching frequency (if applicable). If the GPIO is open-drain, use pullup resistors instead.

Typical Application (continued)

9.2.3 Application Curve

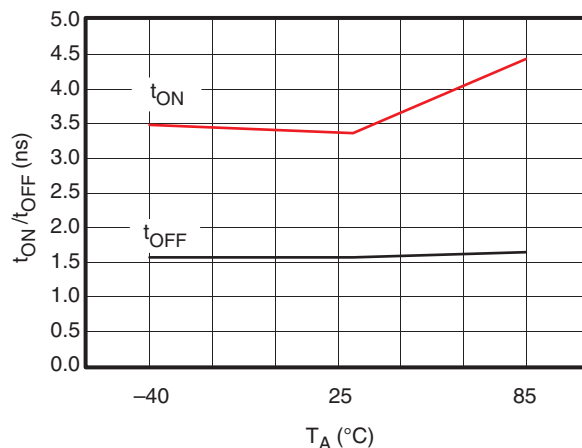

Figure 25. t_{ON} and t_{OFF} vs Temperature ($V_+ = 3.3$ V)

10 Power Supply Recommendations

The power supply can be any voltage between the minimum and maximum supply voltage rating located in the [Recommended Operating Conditions](#).

Each V_{CC} terminal should have a good bypass capacitor to prevent power disturbance. For devices with a single supply, a 0.1- μ F bypass capacitor is recommended. If there are multiple pins labeled V_{CC} , then a 0.01- μ F or 0.022- μ F capacitor is recommended for each V_{CC} because the V_{CC} pins will be tied together internally. For devices with dual-supply pins operating at different voltages, for example V_{CC} and V_{DD} , a 0.1- μ F bypass capacitor is recommended for each supply pin. It is acceptable to parallel multiple bypass capacitors to reject different frequencies of noise. 0.1- μ F and 1- μ F capacitors are commonly used in parallel. The bypass capacitor should be installed as close to the power terminal as possible for best results.

11 Layout

11.1 Layout Guidelines

Reflections and matching are closely related to loop antenna theory, but different enough to warrant their own discussion. When a PCB trace turns a corner at a 90° angle, a reflection can occur. This is primarily due to the change of width of the trace. At the apex of the turn, the trace width is increased to 1.414 times its width. This upsets the transmission line characteristics, especially the distributed capacitance and self-inductance of the trace — resulting in the reflection. It is a given that not all PCB traces can be straight, and so they will have to turn corners. Below figure shows progressively better techniques of rounding corners. Only the last example maintains constant trace width and minimizes reflections.

Unused switch I/Os, such as NO, NC, and COM, can be left floating or tied to GND. However, the IN1, IN2, and EN pins must be driven high or low. Due to partial transistor turnon when control inputs are at threshold levels, floating control inputs can cause increased I_{CC} or unknown switch selection states. See *Implications of Slow or Floating CMOS Inputs*, [SCBA004](#) for more details.

11.2 Layout Example

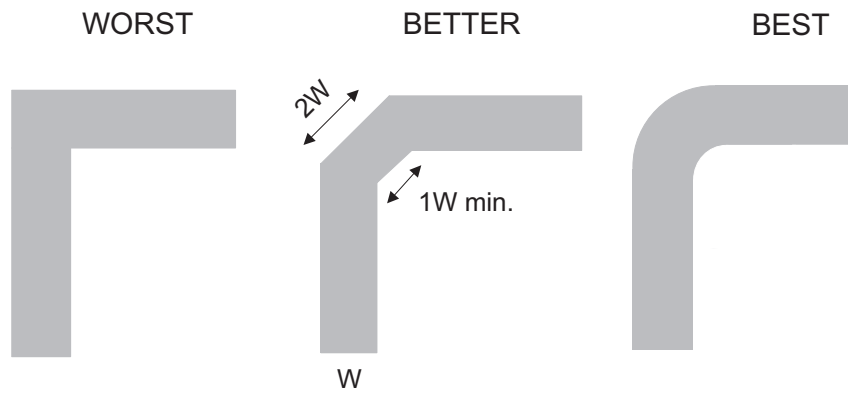

Figure 26. Trace Example

12 Device and Documentation Support

12.1 Device Support

12.1.1 Device Nomenclature

Table 2. Parameter Description

SYMBOL	DESCRIPTION
V_{COM}	Voltage at COM
V_{NC}	Voltage at NC
V_{NO}	Voltage at NO
r_{on}	Resistance between COM and NC or NO ports when the channel is ON
Δr_{on}	Difference of r_{on} between channels in a specific device
$r_{on(flat)}$	Difference between the maximum and minimum value of r_{on} in a channel over the specified range of conditions
$I_{NC(OFF)}$	Leakage current measured at the NC port, with the corresponding channel (NC to COM) in the OFF state
$I_{NC(ON)}$	Leakage current measured at the NC port, with the corresponding channel (NC to COM) in the ON state and the output (COM) open
$I_{NO(OFF)}$	Leakage current measured at the NO port, with the corresponding channel (NO to COM) in the OFF state
$I_{NO(ON)}$	Leakage current measured at the NO port, with the corresponding channel (NO to COM) in the ON state and the output (COM) open
$I_{COM(OFF)}$	Leakage current measured at the COM port, with the corresponding channel (COM to NC or NO) in the OFF state
$I_{COM(ON)}$	Leakage current measured at the COM port, with the corresponding channel (COM to NC or NO) in the ON state and the output (NC or NO) open
V_{IH}	Minimum input voltage for logic high for the control input (IN, \overline{EN})
V_{IL}	Maximum input voltage for logic low for the control input (IN, \overline{EN})
V_I	Voltage at the control input (IN, \overline{EN})
I_{IH}, I_{IL}	Leakage current measured at the control input (IN, \overline{EN})
t_{ON}	Turnon time for the switch. This parameter is measured under the specified range of conditions and by the propagation delay between the digital control (IN) signal and analog output (NC or NO) signal when the switch is turning ON.
t_{OFF}	Turnoff time for the switch. This parameter is measured under the specified range of conditions and by the propagation delay between the digital control (IN) signal and analog output (NC or NO) signal when the switch is turning OFF.
Q_C	Charge injection is a measurement of unwanted signal coupling from the control (IN) input to the analog (NC or NO) output. This is measured in coulomb (C) and measured by the total charge induced due to switching of the control input. Charge injection, $Q_C = C_L \times \Delta V_{COM}$, C_L is the load capacitance and ΔV_{COM} is the change in analog output voltage.
$C_{NC(OFF)}$	Capacitance at the NC port when the corresponding channel (NC to COM) is OFF
$C_{NC(ON)}$	Capacitance at the NC port when the corresponding channel (NC to COM) is ON
$C_{NO(OFF)}$	Capacitance at the NC port when the corresponding channel (NO to COM) is OFF
$C_{NO(ON)}$	Capacitance at the NC port when the corresponding channel (NO to COM) is ON
$C_{COM(OFF)}$	Capacitance at the COM port when the corresponding channel (COM to NC) is OFF
$C_{COM(ON)}$	Capacitance at the COM port when the corresponding channel (COM to NC) is ON
C_I	Capacitance of control input (IN, \overline{EN})
O_{ISO}	OFF isolation of the switch is a measurement of OFF-state switch impedance. This is measured in dB in a specific frequency, with the corresponding channel (NC to COM) in the OFF state.
X_{TALK}	Crosstalk is a measurement of unwanted signal coupling from an ON channel to an OFF channel (NC1 to NO1). Adjacent crosstalk is a measure of unwanted signal coupling from an ON channel to an adjacent ON channel (NC1 to NC2). This is measured in a specific frequency and in dB.
BW	Bandwidth of the switch. This is the frequency in which the gain of an ON channel is –3 dB below the DC gain.
THD	Total harmonic distortion describes the signal distortion caused by the analog switch. This is defined as the ratio of root mean square (RMS) value of the second, third, and higher harmonic to the absolute magnitude of the fundamental harmonic.
I_+	Static power-supply current with the control (IN) pin at V_+ or GND

12.2 Documentation Support

12.2.1 Related Documentation

- *Implications of Slow or Floating CMOS Inputs*, [SCBA004](#)

12.3 Trademarks

All trademarks are the property of their respective owners.

12.4 Electrostatic Discharge Caution



These devices have limited built-in ESD protection. The leads should be shorted together or the device placed in conductive foam during storage or handling to prevent electrostatic damage to the MOS gates.

12.5 Glossary

[SLYZ022](#) — *TI Glossary*.

This glossary lists and explains terms, acronyms, and definitions.

13 Mechanical, Packaging, and Orderable Information

The following pages include mechanical, packaging, and orderable information. This information is the most current data available for the designated devices. This data is subject to change without notice and revision of this document. For browser-based versions of this data sheet, refer to the left-hand navigation.

PACKAGING INFORMATION

Orderable part number	Status (1)	Material type (2)	Package Pins	Package qty Carrier	RoHS (3)	Lead finish/ Ball material (4)	MSL rating/ Peak reflow (5)	Op temp (°C)	Part marking (6)
TS3A5017D	Obsolete	Production	SOIC (D) 16	-	-	Call TI	Call TI	-40 to 85	TS3A5017
TS3A5017DBQR	Active	Production	SSOP (DBQ) 16	2500 LARGE T&R	Yes	NIPDAU	Level-2-260C-1 YEAR	-40 to 85	YA017
TS3A5017DBQR.B	Active	Production	SSOP (DBQ) 16	2500 LARGE T&R	Yes	NIPDAU	Level-2-260C-1 YEAR	-40 to 85	YA017
TS3A5017DBQRG4	Active	Production	SSOP (DBQ) 16	2500 LARGE T&R	Yes	NIPDAU	Level-2-260C-1 YEAR	-40 to 85	YA017
TS3A5017DBQRG4.B	Active	Production	SSOP (DBQ) 16	2500 LARGE T&R	Yes	NIPDAU	Level-2-260C-1 YEAR	-40 to 85	YA017
TS3A5017DGVR	Active	Production	TVSOP (DGV) 16	2000 LARGE T&R	Yes	NIPDAU	Level-1-260C-UNLIM	-40 to 85	YA017
TS3A5017DGVR.B	Active	Production	TVSOP (DGV) 16	2000 LARGE T&R	Yes	NIPDAU	Level-1-260C-UNLIM	-40 to 85	YA017
TS3A5017DR	Active	Production	SOIC (D) 16	2500 LARGE T&R	Yes	NIPDAU	Level-1-260C-UNLIM	-40 to 85	TS3A5017
TS3A5017DR.B	Active	Production	SOIC (D) 16	2500 LARGE T&R	Yes	NIPDAU	Level-1-260C-UNLIM	-40 to 85	TS3A5017
TS3A5017PWR	Active	Production	TSSOP (PW) 16	2000 LARGE T&R	Yes	NIPDAU	Level-1-260C-UNLIM	-40 to 85	YA017
TS3A5017PWR.B	Active	Production	TSSOP (PW) 16	2000 LARGE T&R	Yes	NIPDAU	Level-1-260C-UNLIM	-40 to 85	YA017
TS3A5017RGYR	Active	Production	VQFN (RGY) 16	3000 LARGE T&R	Yes	NIPDAU	Level-2-260C-1 YEAR	-40 to 85	YA017
TS3A5017RGYR.B	Active	Production	VQFN (RGY) 16	3000 LARGE T&R	Yes	NIPDAU	Level-2-260C-1 YEAR	-40 to 85	YA017
TS3A5017RSVR	Active	Production	UQFN (RSV) 16	3000 LARGE T&R	Yes	NIPDAU	Level-1-260C-UNLIM	-40 to 85	ZVL
TS3A5017RSVR.B	Active	Production	UQFN (RSV) 16	3000 LARGE T&R	Yes	NIPDAU	Level-1-260C-UNLIM	-40 to 85	ZVL
TS3A5017RSVRG4	Active	Production	UQFN (RSV) 16	3000 LARGE T&R	Yes	NIPDAU	Level-1-260C-UNLIM	-40 to 85	ZVL
TS3A5017RSVRG4.B	Active	Production	UQFN (RSV) 16	3000 LARGE T&R	Yes	NIPDAU	Level-1-260C-UNLIM	-40 to 85	ZVL

(1) **Status:** For more details on status, see our [product life cycle](#).

(2) **Material type:** When designated, preproduction parts are prototypes/experimental devices, and are not yet approved or released for full production. Testing and final process, including without limitation quality assurance, reliability performance testing, and/or process qualification, may not yet be complete, and this item is subject to further changes or possible discontinuation. If available for ordering, purchases will be subject to an additional waiver at checkout, and are intended for early internal evaluation purposes only. These items are sold without warranties of any kind.

(3) **RoHS values:** Yes, No, RoHS Exempt. See the [TI RoHS Statement](#) for additional information and value definition.

(4) **Lead finish/Ball material:** Parts may have multiple material finish options. Finish options are separated by a vertical ruled line. Lead finish/Ball material values may wrap to two lines if the finish value exceeds the maximum column width.

(5) **MSL rating/Peak reflow:** The moisture sensitivity level ratings and peak solder (reflow) temperatures. In the event that a part has multiple moisture sensitivity ratings, only the lowest level per JEDEC standards is shown. Refer to the shipping label for the actual reflow temperature that will be used to mount the part to the printed circuit board.

⁽⁶⁾ **Part marking:** There may be an additional marking, which relates to the logo, the lot trace code information, or the environmental category of the part.

Multiple part markings will be inside parentheses. Only one part marking contained in parentheses and separated by a "~" will appear on a part. If a line is indented then it is a continuation of the previous line and the two combined represent the entire part marking for that device.

Important Information and Disclaimer: The information provided on this page represents TI's knowledge and belief as of the date that it is provided. TI bases its knowledge and belief on information provided by third parties, and makes no representation or warranty as to the accuracy of such information. Efforts are underway to better integrate information from third parties. TI has taken and continues to take reasonable steps to provide representative and accurate information but may not have conducted destructive testing or chemical analysis on incoming materials and chemicals. TI and TI suppliers consider certain information to be proprietary, and thus CAS numbers and other limited information may not be available for release.

In no event shall TI's liability arising out of such information exceed the total purchase price of the TI part(s) at issue in this document sold by TI to Customer on an annual basis.

OTHER QUALIFIED VERSIONS OF TS3A5017 :

- Automotive : [TS3A5017-Q1](#)

NOTE: Qualified Version Definitions:

- Automotive - Q100 devices qualified for high-reliability automotive applications targeting zero defects

TAPE AND REEL INFORMATION

QUADRANT ASSIGNMENTS FOR PIN 1 ORIENTATION IN TAPE

*All dimensions are nominal

Device	Package Type	Package Drawing	Pins	SPQ	Reel Diameter (mm)	Reel Width W1 (mm)	A0 (mm)	B0 (mm)	K0 (mm)	P1 (mm)	W (mm)	Pin1 Quadrant
TS3A5017DBQR	SSOP	DBQ	16	2500	330.0	12.5	6.4	5.2	2.1	8.0	12.0	Q1
TS3A5017DBQRG4	SSOP	DBQ	16	2500	330.0	12.5	6.4	5.2	2.1	8.0	12.0	Q1
TS3A5017DGVR	TVSOP	DGV	16	2000	330.0	12.4	6.8	4.0	1.6	8.0	12.0	Q1
TS3A5017DR	SOIC	D	16	2500	330.0	16.4	6.5	10.3	2.1	8.0	16.0	Q1
TS3A5017PWR	TSSOP	PW	16	2000	330.0	12.4	6.9	5.6	1.6	8.0	12.0	Q1
TS3A5017RGYR	VQFN	RGY	16	3000	330.0	12.4	3.8	4.3	1.5	8.0	12.0	Q1
TS3A5017RSVR	UQFN	RSV	16	3000	180.0	12.4	2.1	2.9	0.75	4.0	12.0	Q1
TS3A5017RSVRG4	UQFN	RSV	16	3000	180.0	12.4	2.1	2.9	0.75	4.0	12.0	Q1

TAPE AND REEL BOX DIMENSIONS

*All dimensions are nominal

Device	Package Type	Package Drawing	Pins	SPQ	Length (mm)	Width (mm)	Height (mm)
TS3A5017DBQR	SSOP	DBQ	16	2500	353.0	353.0	32.0
TS3A5017DBQRG4	SSOP	DBQ	16	2500	353.0	353.0	32.0
TS3A5017DGVR	TVSOP	DGV	16	2000	353.0	353.0	32.0
TS3A5017DR	SOIC	D	16	2500	353.0	353.0	32.0
TS3A5017PWR	TSSOP	PW	16	2000	353.0	353.0	32.0
TS3A5017RGYR	VQFN	RGY	16	3000	353.0	353.0	32.0
TS3A5017RSVR	UQFN	RSV	16	3000	200.0	183.0	25.0
TS3A5017RSVRG4	UQFN	RSV	16	3000	200.0	183.0	25.0

D (R-PDSO-G16)

PLASTIC SMALL OUTLINE



- NOTES:
- A. All linear dimensions are in inches (millimeters).
 - B. This drawing is subject to change without notice.
 - C. Body length does not include mold flash, protrusions, or gate burrs. Mold flash, protrusions, or gate burrs shall not exceed 0.006 (0,15) each side.
 - D. Body width does not include interlead flash. Interlead flash shall not exceed 0.017 (0,43) each side.
 - E. Reference JEDEC MS-012 variation AC.

GENERIC PACKAGE VIEW

RSV 16

UQFN - 0.55 mm max height

1.8 x 2.6, 0.4 mm pitch

ULTRA THIN QUAD FLATPACK - NO LEAD

This image is a representation of the package family, actual package may vary.
Refer to the product data sheet for package details.

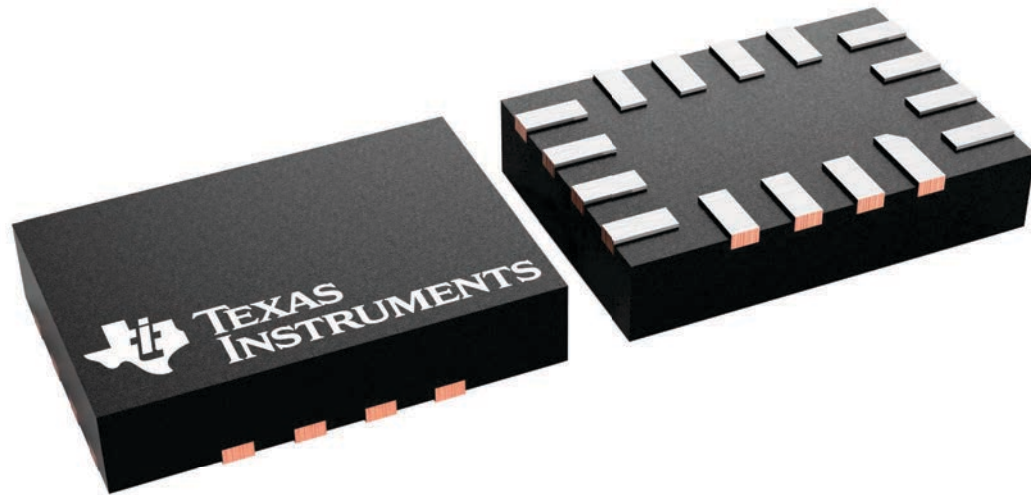

4231225/A

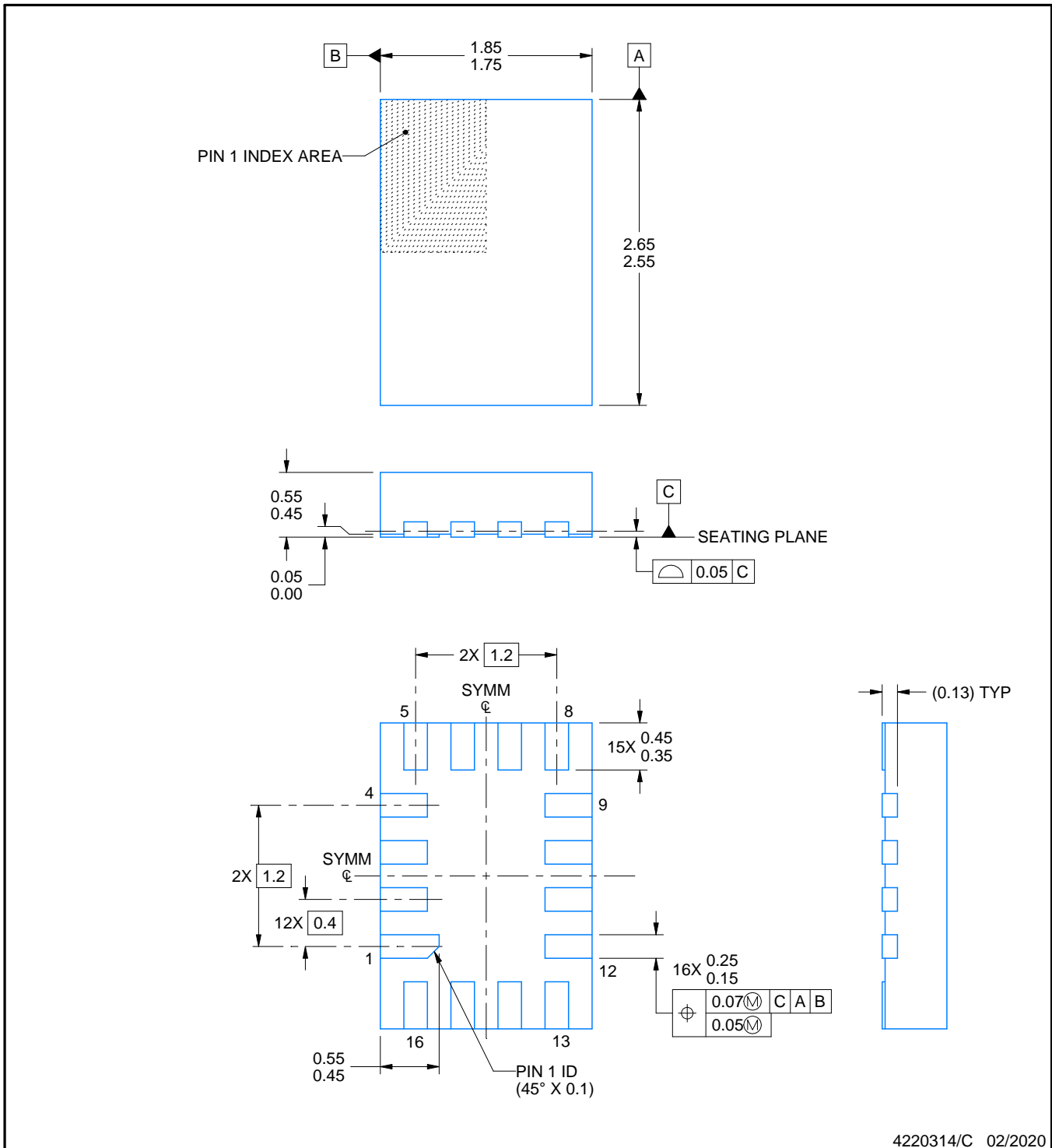
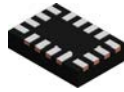

4220314/C 02/2020

NOTES:

1. All linear dimensions are in millimeters. Any dimensions in parenthesis are for reference only. Dimensioning and tolerancing per ASME Y14.5M.
2. This drawing is subject to change without notice.

EXAMPLE BOARD LAYOUT

RSV0016A

UQFN - 0.55 mm max height

ULTRA THIN QUAD FLATPACK - NO LEAD



LAND PATTERN EXAMPLE
EXPOSED METAL SHOWN
SCALE: 25X

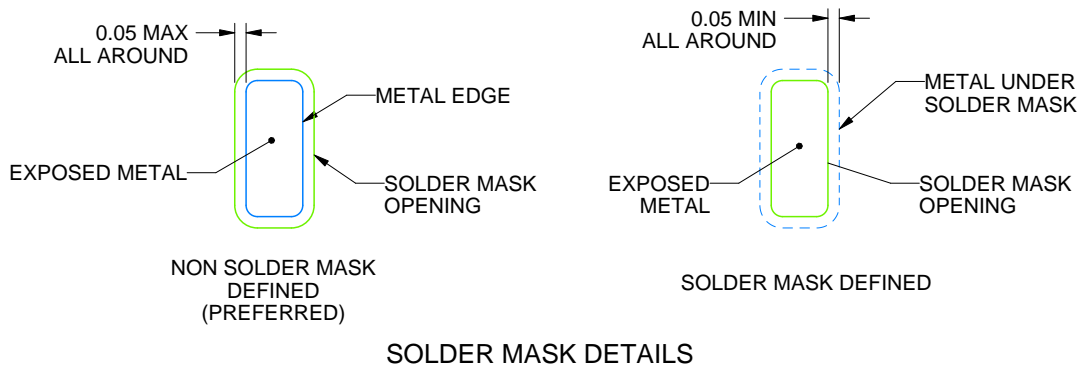

4220314/C 02/2020

NOTES: (continued)

3. For more information, see Texas Instruments literature number SLUA271 (www.ti.com/lit/slua271).

EXAMPLE STENCIL DESIGN

RSV0016A

UQFN - 0.55 mm max height

ULTRA THIN QUAD FLATPACK - NO LEAD



SOLDER PASTE EXAMPLE
BASED ON 0.125 MM THICK STENCIL
SCALE: 25X

4220314/C 02/2020

NOTES: (continued)

4. Laser cutting apertures with trapezoidal walls and rounded corners may offer better paste release. IPC-7525 may have alternate design recommendations.

DGV (R-PDSO-G**)

PLASTIC SMALL-OUTLINE

24 PINS SHOWN



- NOTES: A. All linear dimensions are in millimeters.
 B. This drawing is subject to change without notice.
 C. Body dimensions do not include mold flash or protrusion, not to exceed 0,15 per side.
 D. Falls within JEDEC: 24/48 Pins – MO-153
 14/16/20/56 Pins – MO-194

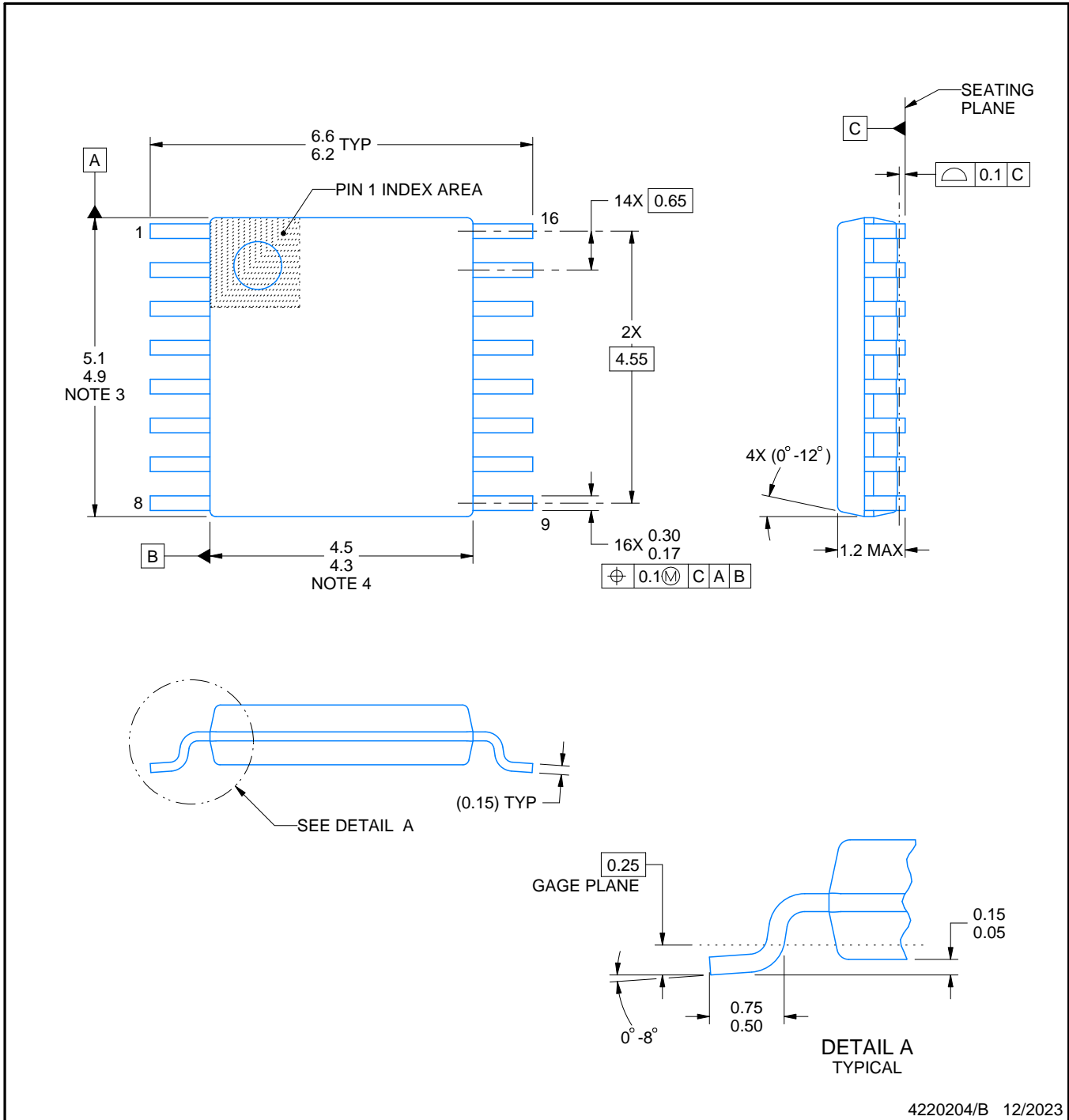

4220204/B 12/2023

NOTES:

1. All linear dimensions are in millimeters. Any dimensions in parenthesis are for reference only. Dimensioning and tolerancing per ASME Y14.5M.
2. This drawing is subject to change without notice.
3. This dimension does not include mold flash, protrusions, or gate burrs. Mold flash, protrusions, or gate burrs shall not exceed 0.15 mm per side.
4. This dimension does not include interlead flash. Interlead flash shall not exceed 0.25 mm per side.
5. Reference JEDEC registration MO-153.

EXAMPLE BOARD LAYOUT

PW0016A

TSSOP - 1.2 mm max height

SMALL OUTLINE PACKAGE



LAND PATTERN EXAMPLE
EXPOSED METAL SHOWN
SCALE: 10X



SOLDER MASK DETAILS

4220204/B 12/2023

NOTES: (continued)

6. Publication IPC-7351 may have alternate designs.
7. Solder mask tolerances between and around signal pads can vary based on board fabrication site.

EXAMPLE STENCIL DESIGN

PW0016A

TSSOP - 1.2 mm max height

SMALL OUTLINE PACKAGE



SOLDER PASTE EXAMPLE
BASED ON 0.125 mm THICK STENCIL
SCALE: 10X

4220204/B 12/2023

NOTES: (continued)

8. Laser cutting apertures with trapezoidal walls and rounded corners may offer better paste release. IPC-7525 may have alternate design recommendations.
9. Board assembly site may have different recommendations for stencil design.

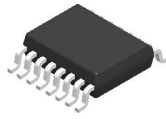

DBQ0016A

PACKAGE OUTLINE

SSOP - 1.75 mm max height

SHRINK SMALL-OUTLINE PACKAGE

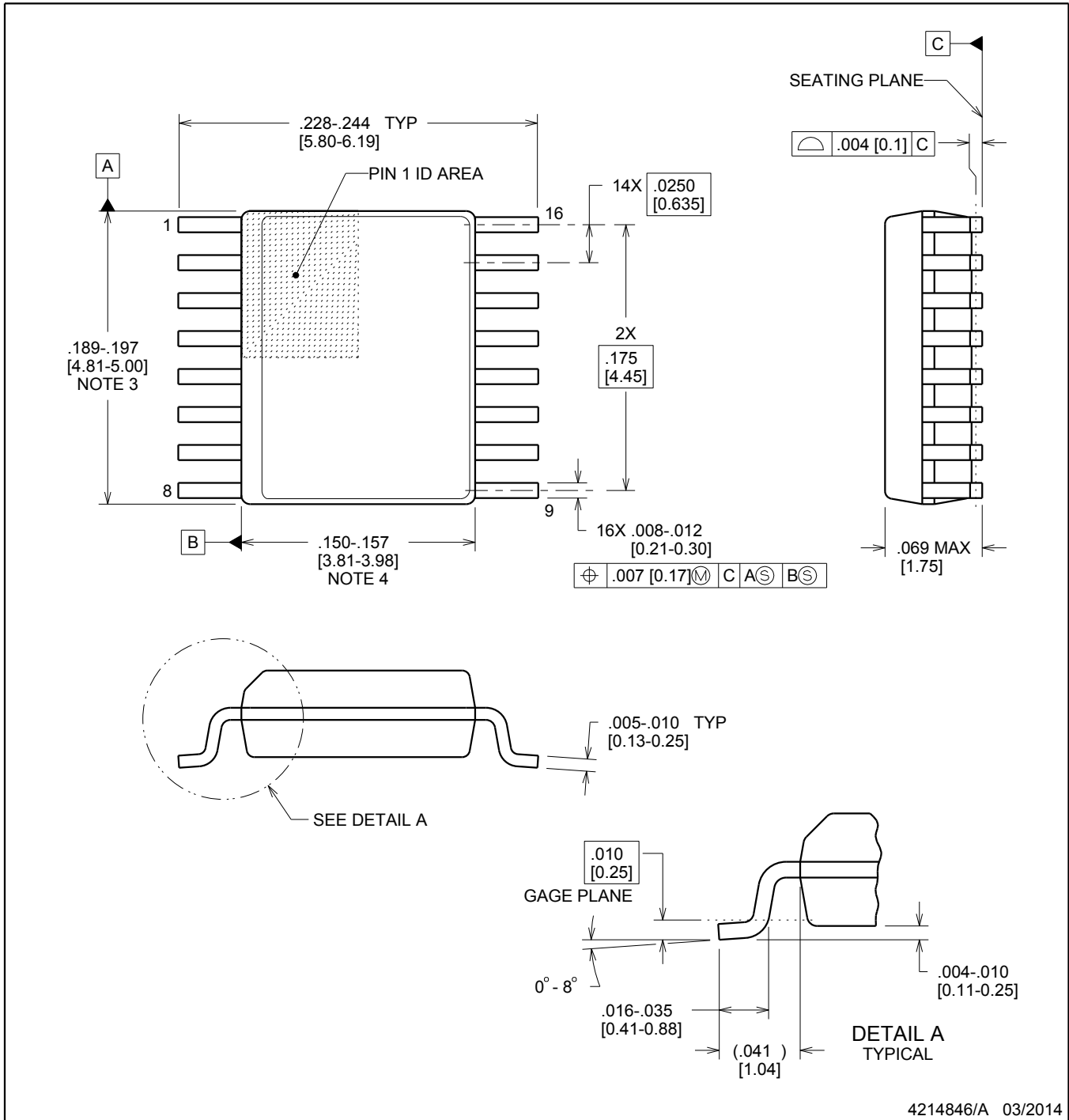

4214846/A 03/2014

NOTES:

- Linear dimensions are in inches [millimeters]. Dimensions in parenthesis are for reference only. Controlling dimensions are in inches. Dimensioning and tolerancing per ASME Y14.5M.
- This drawing is subject to change without notice.
- This dimension does not include mold flash, protrusions, or gate burrs. Mold flash, protrusions, or gate burrs shall not exceed .006 inch, per side.
- This dimension does not include interlead flash.
- Reference JEDEC registration MO-137, variation AB.

EXAMPLE BOARD LAYOUT

DBQ0016A

SSOP - 1.75 mm max height

SHRINK SMALL-OUTLINE PACKAGE



LAND PATTERN EXAMPLE
SCALE:8X



SOLDER MASK DETAILS

4214846/A 03/2014

NOTES: (continued)

- 6. Publication IPC-7351 may have alternate designs.
- 7. Solder mask tolerances between and around signal pads can vary based on board fabrication site.

EXAMPLE STENCIL DESIGN

DBQ0016A

SSOP - 1.75 mm max height

SHRINK SMALL-OUTLINE PACKAGE



SOLDER PASTE EXAMPLE
BASED ON .005 INCH [0.127 MM] THICK STENCIL
SCALE:8X

4214846/A 03/2014

NOTES: (continued)

8. Laser cutting apertures with trapezoidal walls and rounded corners may offer better paste release. IPC-7525 may have alternate design recommendations.
9. Board assembly site may have different recommendations for stencil design.

RGY (R-PVQFN-N16)

PLASTIC QUAD FLATPACK NO-LEAD



4203539-3/1 06/2011

- NOTES:
- All linear dimensions are in millimeters. Dimensioning and tolerancing per ASME Y14.5M-1994.
 - This drawing is subject to change without notice.
 - QFN (Quad Flatpack No-Lead) package configuration.
 - The package thermal pad must be soldered to the board for thermal and mechanical performance.
 - See the additional figure in the Product Data Sheet for details regarding the exposed thermal pad features and dimensions.
 - Pin 1 identifiers are located on both top and bottom of the package and within the zone indicated. The Pin 1 identifiers are either a molded, marked, or metal feature.
 - Package complies to JEDEC MO-241 variation BA.

RGY (R-PVQFN-N16)

PLASTIC QUAD FLATPACK NO-LEAD

THERMAL INFORMATION

This package incorporates an exposed thermal pad that is designed to be attached directly to an external heatsink. The thermal pad must be soldered directly to the printed circuit board (PCB). After soldering, the PCB can be used as a heatsink. In addition, through the use of thermal vias, the thermal pad can be attached directly to the appropriate copper plane shown in the electrical schematic for the device, or alternatively, can be attached to a special heatsink structure designed into the PCB. This design optimizes the heat transfer from the integrated circuit (IC).

For information on the Quad Flatpack No-Lead (QFN) package and its advantages, refer to Application Report, QFN/SON PCB Attachment, Texas Instruments Literature No. SLUA271. This document is available at www.ti.com.

The exposed thermal pad dimensions for this package are shown in the following illustration.



Bottom View

Exposed Thermal Pad Dimensions

4206353-3/P 03/14

NOTE: All linear dimensions are in millimeters

RGY (R-PVQFN-N16)

PLASTIC QUAD FLATPACK NO-LEAD



4208122-3/P 03/14

- NOTES:
- A. All linear dimensions are in millimeters.
 - B. This drawing is subject to change without notice.
 - C. Publication IPC-7351 is recommended for alternate designs.
 - D. This package is designed to be soldered to a thermal pad on the board. Refer to Application Note, Quad Flat-Pack QFN/SON PCB Attachment, Texas Instruments Literature No. SLUA271, and also the Product Data Sheets for specific thermal information, via requirements, and recommended board layout. These documents are available at www.ti.com <<http://www.ti.com>>.
 - E. Laser cutting apertures with trapezoidal walls and also rounding corners will offer better paste release. Customers should contact their board assembly site for stencil design recommendations. Refer to IPC 7525 for stencil design considerations.
 - F. Customers should contact their board fabrication site for minimum solder mask web tolerances between signal pads.

IMPORTANT NOTICE AND DISCLAIMER

TI PROVIDES TECHNICAL AND RELIABILITY DATA (INCLUDING DATASHEETS), DESIGN RESOURCES (INCLUDING REFERENCE DESIGNS), APPLICATION OR OTHER DESIGN ADVICE, WEB TOOLS, SAFETY INFORMATION, AND OTHER RESOURCES "AS IS" AND WITH ALL FAULTS, AND DISCLAIMS ALL WARRANTIES, EXPRESS AND IMPLIED, INCLUDING WITHOUT LIMITATION ANY IMPLIED WARRANTIES OF MERCHANTABILITY, FITNESS FOR A PARTICULAR PURPOSE OR NON-INFRINGEMENT OF THIRD PARTY INTELLECTUAL PROPERTY RIGHTS.

These resources are intended for skilled developers designing with TI products. You are solely responsible for (1) selecting the appropriate TI products for your application, (2) designing, validating and testing your application, and (3) ensuring your application meets applicable standards, and any other safety, security, regulatory or other requirements.

These resources are subject to change without notice. TI grants you permission to use these resources only for development of an application that uses the TI products described in the resource. Other reproduction and display of these resources is prohibited. No license is granted to any other TI intellectual property right or to any third party intellectual property right. TI disclaims responsibility for, and you fully indemnify TI and its representatives against any claims, damages, costs, losses, and liabilities arising out of your use of these resources.

TI's products are provided subject to [TI's Terms of Sale](#), [TI's General Quality Guidelines](#), or other applicable terms available either on ti.com or provided in conjunction with such TI products. TI's provision of these resources does not expand or otherwise alter TI's applicable warranties or warranty disclaimers for TI products. Unless TI explicitly designates a product as custom or customer-specified, TI products are standard, catalog, general purpose devices.

TI objects to and rejects any additional or different terms you may propose.

Copyright © 2025, Texas Instruments Incorporated

Last updated 10/2025