

TX75E16 5-Level, 16-Channel Transmitter with T/R Switch, On-Chip Beamformer, and Enhanced Load Damping Features

1 Features

- Transmitter supports:
 - 16-channel 5-level pulser and active transmit/receive (T/R) switch
- 5-level pulser:
 - Maximum output voltage: $\pm 100\text{V}$
 - Minimum output voltage: $\pm 1\text{V}$
 - Maximum output current: 2A
 - Supports 4A output current mode.
 - True return to zero to discharge output to ground
 - Second harmonic of -45dBc at 5MHz
 - -3dB Bandwidth with $1\text{k}\Omega \parallel 240\text{pF}$ load
 - 20MHz for a $\pm 100\text{V}$ supply
 - 25MHz for a $\pm 70\text{V}$ supply
 - 35MHz for a $\pm 100\text{V}$ supply in 4A mode
 - Integrated jitter: 100 fs measured from 100Hz to 20kHz
 - CW mode close-in phase noise: -154dBc/Hz at 1kHz offset for 5MHz signal
 - Very low receive power: 1mW/ch
 - Programmable load damp resistor: 200 Ω , 100 Ω or 67 Ω
- Active transmit/receive (T/R) switch with:
 - Turn-on resistance: 8 Ω
 - Turn-on and turn-off time: 100ns
 - Transient glitch: 10mV_{PP}
- On-chip beam former with:
 - Channel based T/R switch on and off controls
 - Delay resolution: half beamformer clock period, minimum 2 ns
 - Maximum delay: 2^{14} beamformer clock period
 - Maximum beamformer clock speed: 320MHz
 - Per channel pattern control with 2K distinct level
 - Global and local repeat pattern, enabling long duration patterns for Shear Wave imaging
 - Supports 120 delay profiles
- High-speed (400 MHz maximum), 2-lane LVDS serial programming interface.
 - Low programming time: < 500ns for delay profile update
 - 32-bit checksum feature to detect wrong SPI writes
- Supports CMOS serial programming interface (50MHz maximum)
- Internal temperature sensor and automatic thermal shutdown
- No specific power sequencing requirement

- Error flag register to detect faulty conditions
- Integrated passives for the floating supplies and bias voltages
- Small package: FC-BGA-144 (10mm × 10mm) with 0.8mm pitch

2 Applications

- [Ultrasound scanners](#)
- [Piezo drivers](#)
- [Ultrasound smart probes](#)

3 Description

The TX75E16 is a highly integrated, high-performance transmitter for ultrasound imaging system. The device has total 16 pulser circuits, 16 transmit/receive switches (referred as T/R or TR switches), and supports on-chip beamformer (TxBF). The device also integrates on-chip floating power supplies that reduce the number of required high voltage power supplies.

The TX75E16 has a pulser circuit that generates five-level high voltage pulses (up to $\pm 100\text{V}$) that is used to excite multiple channels of an ultrasound transducer. The device supports total 16 outputs. The maximum output current is 2A.

The device can be used as a transmitter for many applications like ultrasound imaging, non-destructive testing, SONAR, LIDAR, marine navigation system, brain imaging systems and so on.

The TX75E16 (referred as device in this data sheet) is highly integrated transmitter targeted for exciting ultrasound transducers. Device integrates 16 pulsers and 16 T/R switches, on-chip beamformer, and pattern generator.

The device integrates all the decoupling capacitors required for the floating supplies and internal bias voltages. This integration significantly reduces the required number of external capacitors. The TX75E16 is available in a 10mm × 10mm 144-pin FC-BGA package (ALH package) and is specified for operation from 0°C to 70°C.

Package Information

PART NUMBER	PACKAGE ⁽¹⁾	PACKAGE SIZE ⁽²⁾
TX75E16	ALH (FC-BGA, 144)	10mm × 10mm

(1) For all available packages, see [Section 6](#).

(2) The package size (length × width) is a nominal value and includes pins, where applicable.



Pulser circuit generates five-level high voltage pulses (up to ± 100 V) with maximum output current of 2A. When pulser transmits the high voltage pulses, T/R switch turns OFF and protects the low voltage receiver circuit from damage. When the transducer is receiving echo signals, the T/R switch turns ON and connects the transducer to the receiver. The ON/OFF operation of the T/R switch is controlled by on-chip beamforming engine in the device. The T/R switch offers 8Ω impedance in the ON state.

Ultrasound transmission relies on excitation of multiple transducer elements, with different delay values defining the direction of the transmission. Such an operation is referred to as transmit beamforming. The TX75E16 supports staggered pulsing of the different channels, allowing for transmit beamforming.

In the on-chip beamformer mode, delay profile for pulsing of different channels is stored within the device. The device supports a transmit beamformer delay resolution of one beamformer clock period and a maximum delay of 2^{14} beamformer clock periods. An internal pattern generator generates the output pulse patterns based on pattern profiles stored in a profile RAM. Each channel has a RAM, which is 960 words long. The patterns have global and local repeats feature. This capability can be used to generate long patterns and can be used in Shear-Wave imaging.

These pattern profiles and delay profiles are written using a high-speed (400 MHz) serial peripheral interface. The high-speed writes can be prone to errors, therefore the device has a checksum feature to detect errors in SPI writes.

To protect the device from getting damaged because of improper configuration, an internal error flag register can detect faulty condition and configure the device in shutdown mode automatically.

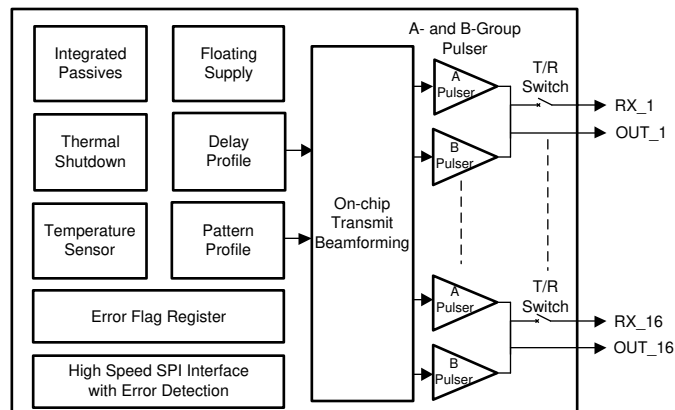

Simplified Block Diagram

Table of Contents

1 Features	1	4.3 Support Resources.....	4
2 Applications	1	4.4 Trademarks.....	4
3 Description	1	4.5 Electrostatic Discharge Caution.....	4
4 Device and Documentation Support	4	4.6 Glossary.....	4
4.1 Document Support.....	4	5 Revision History	4
4.2 Receiving Notification of Documentation Updates.....	4	6 Mechanical, Packaging, and Orderable Information	5

4 Device and Documentation Support

4.1 Document Support

Table 4-1. Terms Commonly Used in the Data Sheet

ABBREVIATION	COMMENT
PRT	Pulse Repetition Time. Represent TR_BF_SYNC period
PRF	Pulse Repetition Frequency. Represent TR_BF_SYNC frequency
Receive Mode	Duration in which T/R switch of all the channels are in ON state
High voltage supplies	AVDDP_HV_A, AVDDP_HV_B, AVDDM_HV_A, and AVDDM_HV_B are collectively referred as high voltage supplies
High voltage supplies	AVDDP_5, AVDDM_5, and AVDDP_1P8 supplies are collectively referred as low voltage supplies
A-side supplies	AVDDP_HV_A and AVDDM_HV_A is referred as A-side supplies
B-side supplies	AVDDP_HV_B and AVDDM_HV_B is referred as B-side supplies
SPI	Serial program interface

4.2 Receiving Notification of Documentation Updates

To receive notification of documentation updates, navigate to the device product folder on ti.com. In the upper right corner, click on *Alert me* to register and receive a weekly digest of any product information that has changed. For change details, review the revision history included in any revised document.

4.3 Support Resources

[TI E2E™ support forums](#) are an engineer's go-to source for fast, verified answers and design help — straight from the experts. Search existing answers or ask your own question to get the quick design help you need.

Linked content is provided "AS IS" by the respective contributors. They do not constitute TI specifications and do not necessarily reflect TI's views; see TI's [Terms of Use](#).

4.4 Trademarks

TI E2E™ is a trademark of Texas Instruments.

All trademarks are the property of their respective owners.

4.5 Electrostatic Discharge Caution



This integrated circuit can be damaged by ESD. Texas Instruments recommends that all integrated circuits be handled with appropriate precautions. Failure to observe proper handling and installation procedures can cause damage.

ESD damage can range from subtle performance degradation to complete device failure. Precision integrated circuits may be more susceptible to damage because very small parametric changes could cause the device not to meet its published specifications.

4.6 Glossary

[TI Glossary](#) This glossary lists and explains terms, acronyms, and definitions.

5 Revision History

NOTE: Page numbers for previous revisions may differ from page numbers in the current version.

Changes from Revision * (December 2023) to Revision A (July 2025)	Page
• Changed the B-side supplies row in Table 4-1	4

6 Mechanical, Packaging, and Orderable Information

The following pages include mechanical, packaging, and orderable information. This information is the most current data available for the designated devices. This data is subject to change without notice and revision of this document. For browser-based versions of this datasheet, refer to the left-hand navigation.

PACKAGING INFORMATION

Orderable part number	Status (1)	Material type (2)	Package Pins	Package qty Carrier	RoHS (3)	Lead finish/ Ball material (4)	MSL rating/ Peak reflow (5)	Op temp (°C)	Part marking (6)
TX75E16ALH	Active	Production	FCCSP (ALH) 144	240 JEDEC TRAY (5+1)	Yes	Call TI Snagcu	Level-3-260C-168 HR	0 to 70	TX75E16

⁽¹⁾ **Status:** For more details on status, see our [product life cycle](#).

⁽²⁾ **Material type:** When designated, preproduction parts are prototypes/experimental devices, and are not yet approved or released for full production. Testing and final process, including without limitation quality assurance, reliability performance testing, and/or process qualification, may not yet be complete, and this item is subject to further changes or possible discontinuation. If available for ordering, purchases will be subject to an additional waiver at checkout, and are intended for early internal evaluation purposes only. These items are sold without warranties of any kind.

⁽³⁾ **RoHS values:** Yes, No, RoHS Exempt. See the [TI RoHS Statement](#) for additional information and value definition.

⁽⁴⁾ **Lead finish/Ball material:** Parts may have multiple material finish options. Finish options are separated by a vertical ruled line. Lead finish/Ball material values may wrap to two lines if the finish value exceeds the maximum column width.

⁽⁵⁾ **MSL rating/Peak reflow:** The moisture sensitivity level ratings and peak solder (reflow) temperatures. In the event that a part has multiple moisture sensitivity ratings, only the lowest level per JEDEC standards is shown. Refer to the shipping label for the actual reflow temperature that will be used to mount the part to the printed circuit board.

⁽⁶⁾ **Part marking:** There may be an additional marking, which relates to the logo, the lot trace code information, or the environmental category of the part.

Multiple part markings will be inside parentheses. Only one part marking contained in parentheses and separated by a "-" will appear on a part. If a line is indented then it is a continuation of the previous line and the two combined represent the entire part marking for that device.

Important Information and Disclaimer: The information provided on this page represents TI's knowledge and belief as of the date that it is provided. TI bases its knowledge and belief on information provided by third parties, and makes no representation or warranty as to the accuracy of such information. Efforts are underway to better integrate information from third parties. TI has taken and continues to take reasonable steps to provide representative and accurate information but may not have conducted destructive testing or chemical analysis on incoming materials and chemicals. TI and TI suppliers consider certain information to be proprietary, and thus CAS numbers and other limited information may not be available for release.

In no event shall TI's liability arising out of such information exceed the total purchase price of the TI part(s) at issue in this document sold by TI to Customer on an annual basis.

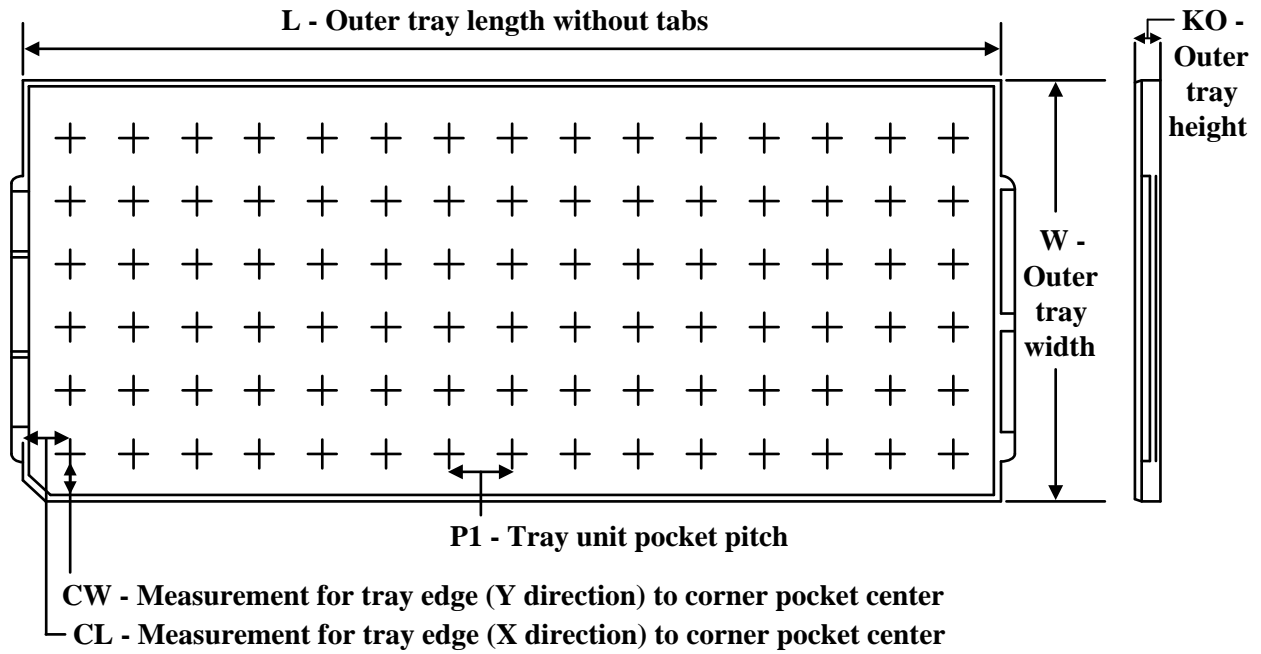
TRAY

Chamfer on Tray corner indicates Pin 1 orientation of packed units.

*All dimensions are nominal

Device	Package Name	Package Type	Pins	SPQ	Unit array matrix	Max temperature (°C)	L (mm)	W (mm)	K0 (µm)	P1 (mm)	CL (mm)	CW (mm)
TX75E16ALH	ALH	FCCSP	144	240	10 x 24	150	315	131.95	7490	15.07	12.9	12.8

IMPORTANT NOTICE AND DISCLAIMER

TI PROVIDES TECHNICAL AND RELIABILITY DATA (INCLUDING DATASHEETS), DESIGN RESOURCES (INCLUDING REFERENCE DESIGNS), APPLICATION OR OTHER DESIGN ADVICE, WEB TOOLS, SAFETY INFORMATION, AND OTHER RESOURCES "AS IS" AND WITH ALL FAULTS, AND DISCLAIMS ALL WARRANTIES, EXPRESS AND IMPLIED, INCLUDING WITHOUT LIMITATION ANY IMPLIED WARRANTIES OF MERCHANTABILITY, FITNESS FOR A PARTICULAR PURPOSE OR NON-INFRINGEMENT OF THIRD PARTY INTELLECTUAL PROPERTY RIGHTS.

These resources are intended for skilled developers designing with TI products. You are solely responsible for (1) selecting the appropriate TI products for your application, (2) designing, validating and testing your application, and (3) ensuring your application meets applicable standards, and any other safety, security, regulatory or other requirements.

These resources are subject to change without notice. TI grants you permission to use these resources only for development of an application that uses the TI products described in the resource. Other reproduction and display of these resources is prohibited. No license is granted to any other TI intellectual property right or to any third party intellectual property right. TI disclaims responsibility for, and you fully indemnify TI and its representatives against any claims, damages, costs, losses, and liabilities arising out of your use of these resources.

TI's products are provided subject to [TI's Terms of Sale](#), [TI's General Quality Guidelines](#), or other applicable terms available either on ti.com or provided in conjunction with such TI products. TI's provision of these resources does not expand or otherwise alter TI's applicable warranties or warranty disclaimers for TI products. Unless TI explicitly designates a product as custom or customer-specified, TI products are standard, catalog, general purpose devices.

TI objects to and rejects any additional or different terms you may propose.

Copyright © 2026, Texas Instruments Incorporated

Last updated 10/2025