

FEATURES

- **Controlled Baseline**
 - One Assembly/Test Site, One Fabrication Site
 - Extended Temperature Performance of -55°C to 125°C
- **Enhanced Diminishing Manufacturing Sources (DMS) Support**
- **Enhanced Product-Change Notification**
- **Qualification Pedigree ⁽¹⁾**
- **Enhanced Replacements for UC2842A Family With Pin-to-Pin Compatibility**
- **1 MHz Operation**
- **50 μA Standby Current, 100 μA Maximum**

(1) Component qualification in accordance with JEDEC and industry standards to ensure reliable operation over an extended temperature range. This includes, but is not limited to, Highly Accelerated Stress Test (HAST) or biased 85/85, temperature cycle, autoclave or unbiased HAST, electromigration, bond intermetallic life, and mold compound life. Such qualification testing should not be viewed as justifying use of this component beyond specified performance and environmental limits.

- **Low Operating Current of 2.3 mA at 52 kHz**
- **Fast 35 ns Cycle-by-Cycle Overcurrent Limiting**
- **± 1 A Peak Output Current**
- **Rail-to-Rail Output Swings With 25 ns Rise and 20 ns Fall Times**
- **$\pm 1\%$ Initial Trimmed 2.5 V Error Amplifier Reference**
- **Trimmed Oscillator Discharge Current**
- **New Undervoltage Lockout Versions**
- **MSOP-8 Package Minimizes Board Space**

APPLICATIONS

- **Switch Mode Power Supplies**
- **DC-to-DC Converters**
- **Board Mount Power Modules**

DESCRIPTION

The UCC28C4x family are high performance current mode PWM controllers. They are enhanced BiCMOS versions with pin-for-pin compatibility to the industry standard UC284xA family and UC284x family of PWM controllers. In addition, lower startup voltage versions of 7 V are offered as UCC28C40 and UCC28C41.

Providing necessary features to control fixed frequency, peak current mode power supplies, this family offers several performance advantages. These devices offer high frequency operation up to 1 MHz with low start up and operating currents, thus minimizing start up loss and low operating power consumption for improved efficiency. The devices also feature a fast current sense to output delay time of 35 ns, and a ± 1 A peak output current capability with improved rise and fall times for driving large external MOSFETs directly.

The UCC28C4x family is offered in 8-pin package SOIC (D).



Please be aware that an important notice concerning availability, standard warranty, and use in critical applications of Texas Instruments semiconductor products and disclaimers thereto appears at the end of this data sheet.

AVAILABLE OPTIONS

T_A	MAXIMUM DUTY CYCLE	UVLO ON/OFF	SOIC-8 SMALL OUTLINE (D) ⁽¹⁾
-55°C to 125°C	100%	14.5 V/9 V	UCC28C42MDREP ⁽²⁾
		8.4 V/7.6 V	UCC28C43MDREP
		7 V/6.6 V	UCC28C40MDREP ⁽²⁾
	50%	14.5 V/9 V	UCC28C44MDREP ⁽²⁾
		8.4 V/7.6 V	UCC28C45MDREP
		7 V/6.6 V	UCC28C41MDREP ⁽²⁾

- (1) D (SOIC-8) packages are available taped and reeled. Add R suffix to device type (e.g., UCC28C42DREP) to order quantities of 2500 devices per reel. Tube quantities are 75 for D packages (SOIC-8).
 (2) Product Preview

FUNCTIONAL BLOCK DIAGRAM

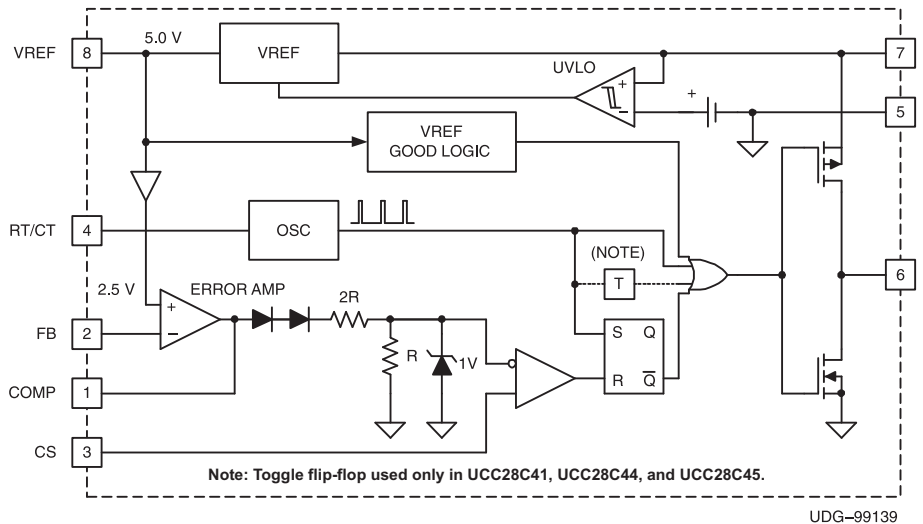

Absolute Maximum Ratings⁽¹⁾⁽²⁾

over operating free-air temperature range (unless otherwise noted)

		MIN	MAX	UNIT
Supply voltage	VDD		20	V
	Max I _{CC}		30	mA
Output current, I _{OUT} peak			±1	A
Output energy, capacitive load			5	μJ
Voltage rating	COMP, CS, FB	-0.3	6.3	V
	OUT	-0.3	20	
	RT/CT	-0.3	6.3	
	VREF		7	
Error amplifier output sink current			10	mA
T _J	Operating junction temperature range ⁽³⁾	-55	150	°C
T _{stg}	Storage temperature range	-65	150	°C
Lead temperature (soldering, 10 s)			300	°C

- (1) Stresses beyond those listed under "absolute maximum ratings" may cause permanent damage to the device. These are stress ratings only, and functional operation of the device at these or any other conditions beyond those indicated under "recommended operating conditions" is not implied. Exposure to absolute-maximum-rated conditions for extended periods may affect device reliability.
- (2) All voltages are with respect to ground. Currents are positive into and negative out of the specified terminals.
- (3) Long-term high temperature storage and/or extended use at maximum recommended operating conditions may result in a reduction of overall device life. See http://www.ti.com/ep_quality for additional information about enhanced plastic packaging.

Dissipation Ratings

PACKAGE	θ _{ja} (°C/W)	T _A < 25°C POWER RATING	DERATING FACTOR ABOVE T _A = 25°C	T _A = 70°C POWER RATING	T _A = 85°C POWER RATING	T _A = 125°C POWER RATING
D	176	710 mW	5.68 mW/°C	454 mW	369 mW	142 mW

Recommended Operating Conditions

		MIN	MAX	UNIT
V _{DD}	Input voltage		18	V
V _{OUT}	Output voltage range		18	V
I _{OUT} ⁽¹⁾	Average output current		200	mA
I _{OUT(ref)} ⁽¹⁾	Reference output current		-20	mA
T _J ⁽¹⁾	Operating junction temperature	-55	150	°C

- (1) It is not recommended that the device operate under conditions beyond those specified in this table for extended periods of time.

Electrical Characteristics

$V_{DD} = 15\text{ V}^{(1)}$, $R_T = 10\text{ k}\Omega$, $C_T = 3.3\text{ nF}$, $C_{VDD} = 0.1\text{ }\mu\text{F}$ and no load on the outputs, $T_A = T_J = -55^\circ\text{C}$ to 125°C for the UCC28C4x

PARAMETER	TEST CONDITIONS	MIN	TYP	MAX	UNIT
Reference					
Output voltage, initial accuracy	$T_A = 25^\circ\text{C}$, $I_{OUT} = 1\text{ mA}$	4.9	5	5.1	V
Line regulation	$V_{DD} = 12\text{ V}$ to 18 V		0.2	20	mV
Load regulation	1 mA to 20 mA		3	25	mV
Temperature stability	⁽²⁾		0.2	0.4	mV/°C
Total output variation	⁽²⁾	4.82		5.18	V
Output noise voltage	10 Hz to 10 kHz, $T_A = 25^\circ\text{C}$		50		μV
Long term stability	1000 hours, $T_A = 125^\circ\text{C}^{(2)}$		5	25	mV
Output short circuit		-30	-45	-55	mA
Oscillator					
Initial accuracy	$T_A = 25^\circ\text{C}^{(3)}$	50.5	53	55	kHz
	$T_A = \text{Full Range}^{(3)}$	50.5		57	KHz
Voltage stability	$V_{DD} = 12\text{ V}$ to 18 V		0.2	2.85	%
Temperature stability	T_{MIN} to $T_{MAX}^{(2)}$		1	2.5	%
Amplitude	RT/CT pin peak to peak		1.9		V
Discharge current	$T_A = 25^\circ\text{C}$, RT/CT = 2 V ⁽⁴⁾	7.7	8.4	9	mA
	RT/CT = 2 V ⁽⁴⁾	7.2	8.4	9.5	mA
Error Amplifier					
Feedback input voltage, initial accuracy	$V_{COMP} = 2.5\text{ V}$, $T_A = 25^\circ\text{C}$	2.475	2.500	2.525	V
Feedback input voltage, total variation	$V_{COMP} = 2.5\text{ V}$	2.45	2.50	2.55	V
Input bias current			-0.1	-2	μA
A_{VOL} Open-loop voltage gain	$V_{OUT} = 2\text{ V}$ to 4 V	65	90		dB
Unity gain bandwidth			1.5		MHz
PSRR Power-supply rejection ratio	$V_{DD} = 12\text{ V}$ to 18 V	60			dB
Output sink current	$V_{FB} = 2.7\text{ V}$, $V_{COMP} = 1.1\text{ V}$	2	14		mA
Output source current	$V_{FB} = 2.3\text{ V}$, $V_{COMP} = 5\text{ V}$	-0.5	-1		mA
V_{OH} High-level output voltage	$V_{FB} = 2.3\text{ V}$, $R_{LOAD} = 15\text{ k}$ to GND	5	6.8		V
V_{OL} Low-level output voltage	$V_{FB} = 2.7\text{ V}$, $R_{LOAD} = 15\text{ k}$ to VREF		0.1	1.1	V
Current Sense					
Gain	$T_A = 25^\circ\text{C}^{(5)(6)}$	2.85	3	3.15	V/V
	$T_A = \text{Full Range}^{(5)(6)}$	2.825		3.15	V/V
Maximum input signal	$V_{FB} < 2.4\text{ V}$	0.9	1	1.1	V
PSRR Power-supply rejection ratio	$V_{DD} = 12\text{ V}$ to $18\text{ V}^{(2)(5)}$		70		dB
Input bias current			-0.1	-2	μA
CS to output delay			35	70	ns
COMP to CS offset	$V_{CS} = 0\text{ V}$		1.15		V
Output					
V_{OUT} low ($R_{DS(on)}$ pull-down)	$I_{SINK} = 200\text{ mA}$		5.5	15	Ω
V_{OUT} high ($R_{DS(on)}$ pull-up)	$I_{SOURCE} = 200\text{ mA}$		10	25	Ω

- (1) Adjust V_{DD} above the start threshold before setting at 15 V.
- (2) Not production tested.
- (3) Output frequencies of the UCC28C41, UCC28C44, and UCC28C45 are one-half the oscillator frequency.
- (4) Oscillator discharge current is measured with $R_T = 10\text{ k}\Omega$ to V_{REF} .
- (5) Parameter measured at trip point of latch with $V_{FB} = 0\text{ V}$.

(6) Gain is defined as
$$ACS = \frac{\Delta V_{COM}}{\Delta V_{CS}}, 0\text{ V} \leq V_{CS} \leq 900\text{ mV}$$

Electrical Characteristics (continued)

$V_{DD} = 15\text{ V}$, $R_T = 10\text{ k}\Omega$, $C_T = 3.3\text{ nF}$, $C_{VDD} = 0.1\text{ }\mu\text{F}$ and no load on the outputs, $T_A = T_J = -55^\circ\text{C}$ to 125°C for the UCC28C4x

PARAMETER	TEST CONDITIONS	MIN	TYP	MAX	UNIT
Rise time	$T_A = 25^\circ\text{C}$, $C_{LOAD} = 1\text{ nF}$		25	50	ns
Fall time	$T_A = 25^\circ\text{C}$, $C_{LOAD} = 1\text{ nF}$		20	40	ns
Undervoltage Lockout (UVLO)					
Start threshold	UCC28C42-EP, UCC28C44-EP	13.5	14.5	15.5	V
	UCC28C43-EP, UCC28C45-EP	7.8	8.4	9	
	UCC28C40-EP, UCC28C41-EP	6.5	7	7.5	
Minimum operating voltage	UCC28C42-EP, UCC28C44-EP	8	9	10	V
	UCC28C43-EP, UCC28C45-EP	7	7.6	8.2	
	UCC28C40-EP, UCC28C41-EP	6.1	6.6	7.1	
PWM					
Maximum duty cycle	UCC28C42-EP, UCC28C43-EP, UCC28C40-EP, UCC28C44-EP, UCC28C45-EP, UCC28C41-EP	94	96		%
		47	48		
Minimum duty cycle				0%	
Current Supply					
$I_{START-UP}$ Start-up current	$V_{DD} = \text{UVLO start threshold } (-0.5\text{ V})$		50	100	μA
I_{DD} Operating supply current	$V_{FB} = V_{CS} = 0\text{ V}$		2.3	3	mA

PDIP (P) or SOIC (D) PACKAGE
(TOP VIEW)

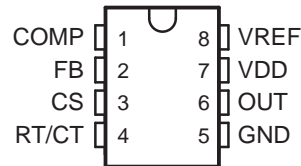

Pin Assignments

COMP: This pin provides the output of the error amplifier for compensation. In addition, the COMP pin is frequently used as a control port by utilizing a secondary-side error amplifier to send an error signal across the secondary-primary isolation boundary through an opto-isolator.

CS: The current-sense pin is the noninverting input to the PWM comparator. This is compared to a signal proportional to the error amplifier output voltage. A voltage ramp can be applied to this pin to run the device with a voltage mode control configuration.

FB: This pin is the inverting input to the error amplifier. The noninverting input to the error amplifier is internally trimmed to $2.5\text{ V} \pm 1\%$.

GND: Ground return pin for the output driver stage and the logic-level controller section.

OUT: The output of the on-chip drive stage. OUT is intended to directly drive a MOSFET. The OUT pin in the UCC28C40, UCC28C42, and UCC28C43 is the same frequency as the oscillator, and can operate near 100% duty cycle. In the UCC28C41, UCC28C44, and the UCC28C45, the frequency of OUT is one-half that of the oscillator due to an internal T flipflop. This limits the maximum duty cycle to $<50\%$.

RT/CT: Timing resistor and timing capacitor. The timing capacitor should be connected to the device ground using minimal trace length.

VDD: Power supply pin for the device. This pin should be bypassed with a $0.1\text{ }\mu\text{F}$ capacitor with minimal trace lengths. Additional capacitance may be needed to provide hold up power to the device during startup.

UCC28C4x-EP BiCMOS LOW-POWER CURRENT-MODE PWM CONTROLLERS

SGLS352B–DECEMBER 2006–REVISED MAY 2007

VREF: 5-V reference. For stability, the reference should be bypassed with a 0.1 μ F capacitor to ground using the minimal trace length possible.

APPLICATION INFORMATION

This device is a pin-for-pin replacement of the bipolar UC2842 family of controllers—the industry standard PWM controller for single-ended converters. Familiarity with this controller family is assumed.

The UCC28C4x series is an enhanced replacement with pin-to-pin compatibility to the bipolar UC284x and UC284xA families. The new series offers improved performance when compared to older bipolar devices and other competitive BiCMOS devices with similar functionality. Note that these improvements discussed below generally consist of tighter specification limits that are a subset of the older product ratings, maintaining drop-in capability. In new designs these improvements can be utilized to reduce the component count or enhance circuit performance when compared to the previously available devices.

Advantages

This device increases the total circuit efficiency whether operating off-line or in dc input circuits. In off-line applications the low start-up current of this device reduces steady state power dissipation in the startup resistor, and the low operating current maximizes efficiency while running. The low running current also provides an efficiency boost in battery-operated supplies.

Low-Voltage Operation

Two members of the UCC28C4x family are intended for applications that require a lower start-up voltage than the original family members. The UCC28C40 and UCC28C41 have a turn-on voltage of 7 V typical and exhibit hysteresis of 0.4 V for a turn-off voltage of 6.6 V. This reduced start-up voltage enables use in systems with lower voltages, such as 12 V battery systems that are nearly discharged.

High-Speed Operation

The BiCMOS design allows operation at high frequencies that were not feasible in the predecessor bipolar devices. First, the output stage has been redesigned to drive the external power switch in approximately one-half the time of the earlier devices. Second, the internal oscillator is more robust, with less variation as frequency increases. In addition, the current sense to output delay has been reduced by a factor of three, to 45 ns typical. These features combine to provide a device capable of reliable high-frequency operation.

The UCC28C4x family oscillator is true to the curves of the original bipolar devices at lower frequencies, yet extends the frequency programmability range to at least 1 MHz. This allows the device to offer pin-to-pin capability where required, yet capable of extending the operational range to the higher frequencies typical of latest applications. When the original UC2842 was released in 1984, most switching supplies operated between 20 kHz and 100 kHz. Today, the UCC28C4x can be used in designs cover a span roughly ten times higher than those numbers.

Start/Run Current Improvements

The start-up current is only 60 μ A typical, a significant reduction from the bipolar device's ratings of 300 μ A (UC284xA). For operation over the temperature range of -55°C to 125°C , the UCC28C4x devices offer a maximum startup current of 100 μ A, an improvement over competitive BiCMOS devices. This allows the power-supply designer to further optimize the selection of the start-up resistor value to provide a more efficient design. In applications where low component cost overrides maximum efficiency the low run current of 2.3 mA typical may allow the control device to run directly through the single resistor to (+) rail, rather than needing a bootstrap winding on the power transformer, along with a rectifier. The start/run resistor for this case must also pass enough current to allow driving the primary switching MOSFET, which may be a few milliamps in small devices.

$\pm 1\%$ Initial Reference Voltage

The BiCMOS internal reference of 2.5 V has an enhanced design and utilizes production trim to allow initial accuracy of $\pm 1\%$ at room temperature and $\pm 2\%$ over the full temperature range. This can be used to eliminate an external reference in applications that do not require the extreme accuracy afforded by the additional device. This is very useful for nonisolated dc-to-dc applications where the control device is referenced to the same common as the output. It is also applicable in offline designs that regulate on the primary side of the isolation boundary by looking at a primary bias winding, or perhaps from a winding on the output inductor of a buck-derived circuit.

APPLICATION INFORMATION (continued)

Reduced Discharge Current Variation

The original UC2842 oscillator did not have trimmed discharged current, and the parameter was not specified on the data sheet. Since many customers attempted to use the discharge current to set a crude dead-time limit, the UC2842A family was released with a trimmed discharge current specified at 25°C. The UCC28C4x series now offers even tighter control of this parameter, with approximately ±3% accuracy at 25°C, and less than 10% variation over temperature using the UCC28C4x devices. This level of accuracy can enable a meaningful limit to be programmed, a feature not currently seen in competitive BiCMOS devices. The improved oscillator and reference also contribute to decreased variation in the peak-to-peak variation in the oscillator waveform, which is often used as the basis for slope compensation for the complete power system.

Soft-Start

Figure 1 provides a typical soft-start circuit for use with the UCC28C42. The values of R and C should be selected to bring the COMP pin up at a controlled rate, limiting the peak current supplied by the power stage. After the soft-start interval is complete, the capacitor continues to charge to V_{REF} , effectively removing the PNP transistor from circuit considerations.

The optional diode in parallel with the resistor forces a soft-start each time the PWM goes through UVLO and the reference (V_{REF}) goes low. Without the diode, the capacitor otherwise remains charged during a brief loss of supply or brownout, and no soft-start is enabled upon reapplication of V_{IN} .

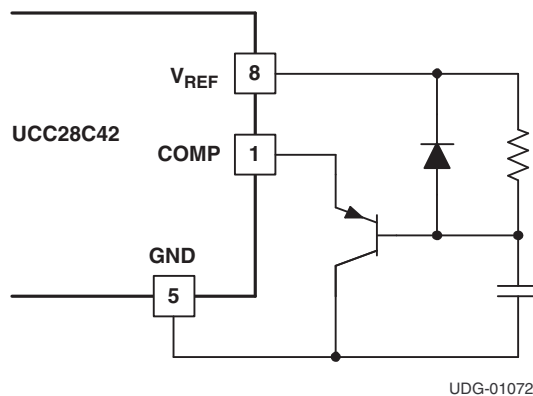

Figure 1.

Oscillator Synchronization

The UCC28C4x oscillator has the same synchronization characteristics as the original bipolar devices. Thus, the information in the application report U-100A, *UC2842/3/4/5 Provides Low-Cost Current-Mode Control* (SLUA143) still applies. The application report describes how a small resistor from the timing capacitor to ground can offer an insertion point for synchronization to an external clock (see Figure 2 and Figure 3). Figure 2 shows how the UCC28C42 can be synchronized to an external clock source. This allows precise control of frequency and dead time with a digital pulse train.

APPLICATION INFORMATION (continued)

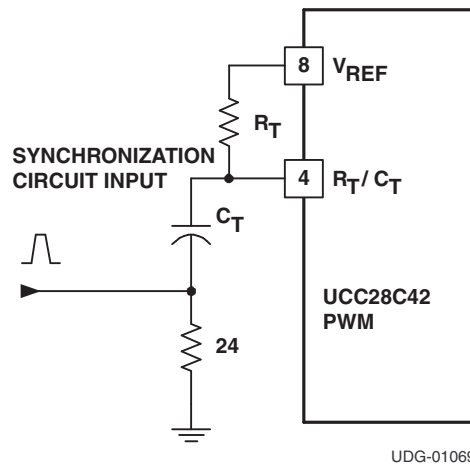

Figure 2. Oscillator Synchronization Circuit

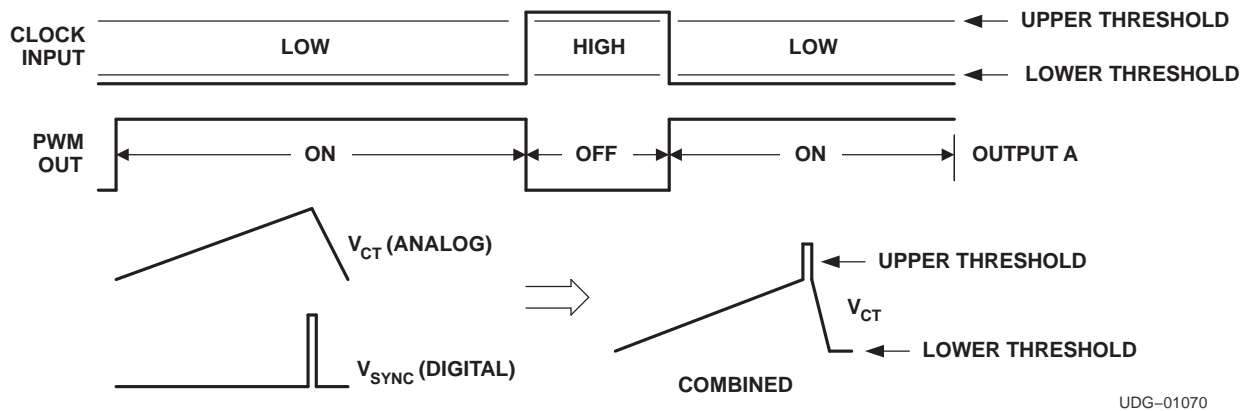

Figure 3. Synchronization to an External Clock

Precautions

The absolute maximum supply voltage is 20 V, including any transients that may be present. If this voltage is exceeded, device damage is likely. This is in contrast to the predecessor bipolar devices that could survive up to 30 V. Thus, the supply pin should be decoupled as close to the ground pin as possible. Also, since no clamp is included in the device, the supply pin should be protected from external sources that could exceed the 20 V level.

Careful layout of the printed board has always been a necessity for high-frequency power supplies. As the device switching speeds and operating frequencies increase, the layout of the converter becomes increasingly important.

This 8-pin device has only a single ground for the logic and power connections. This forces the gate drive current pulses to flow through the same ground that the control circuit uses for reference. Thus, the interconnect inductance should be minimized as much as possible. One implication is to place the device (gate driver) circuitry close to the MOSFET it is driving. Note that this can conflict with the need for the error amplifier and the feedback path to be away from the noise generating components.

Circuit Applications

Figure 4 shows a typical off-line application.

APPLICATION INFORMATION (continued)

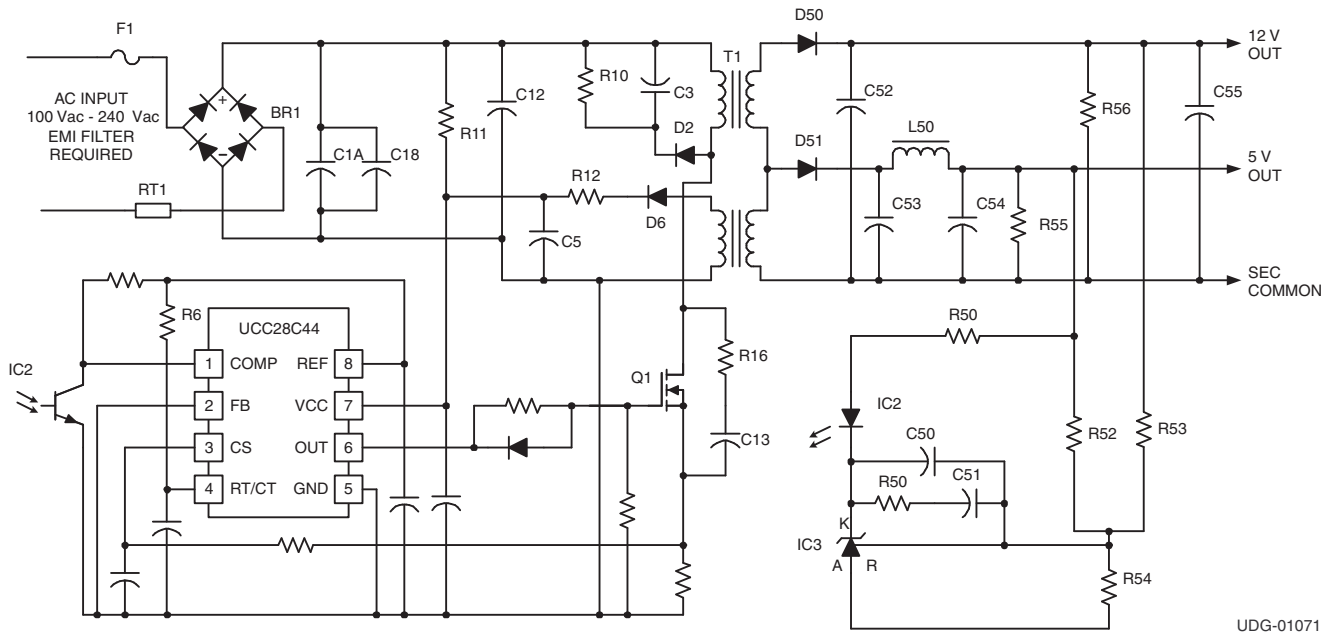

UDG-01071

Figure 4. Typical Off-Line Application

Figure 5 shows the forward converter with synchronous rectification. This application provides 48 V to 3.3 V at 10 A with over 85% efficiency, and uses the UCC28C42 as the secondary-side controller and UCC3961 as the primary-side startup control device.

APPLICATION INFORMATION (continued)

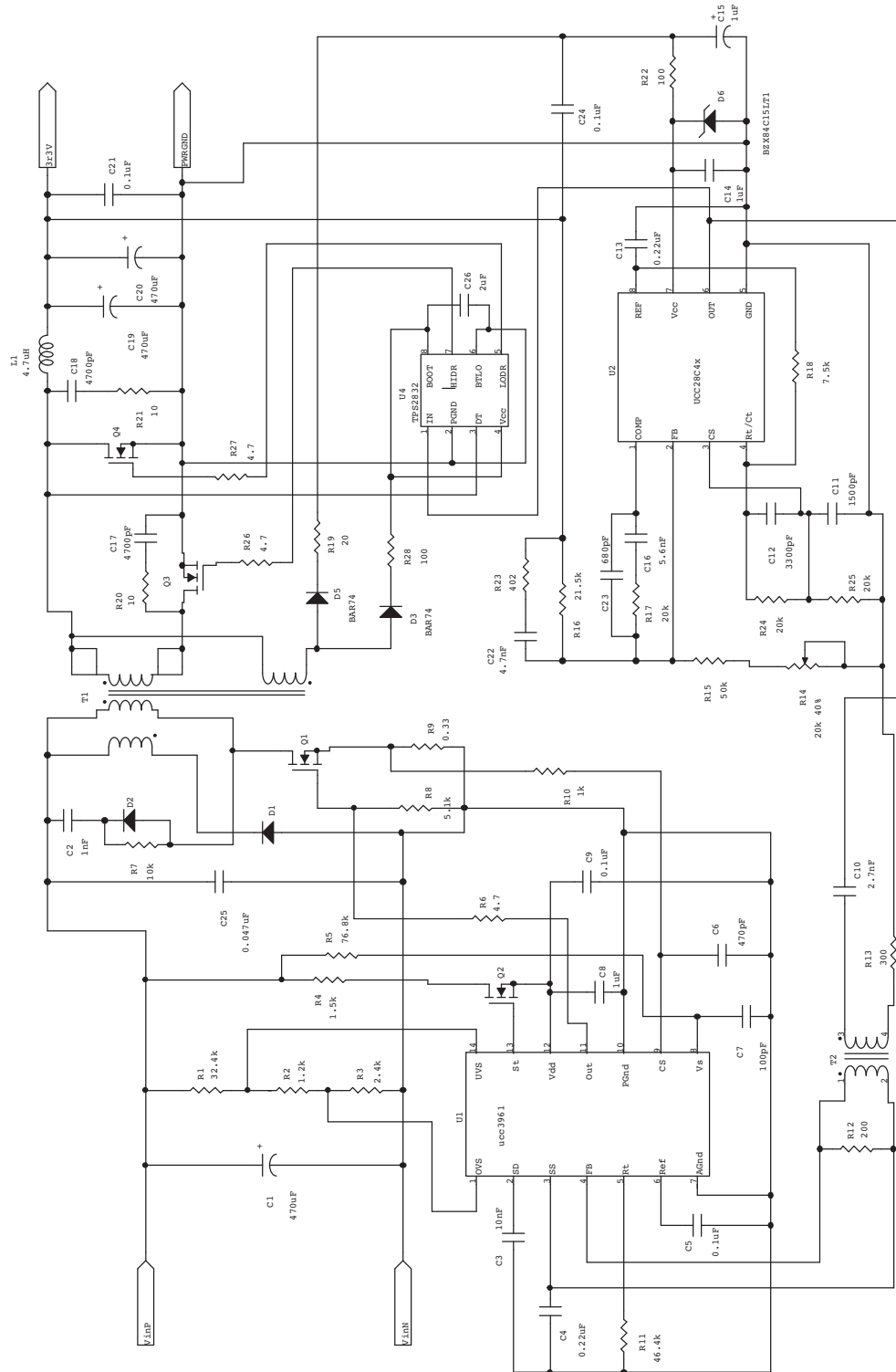

Figure 5. Forward Converter With Synchronous Rectification Using the UCC28C42 as the Secondary-Side Controller

APPLICATION INFORMATION (continued)

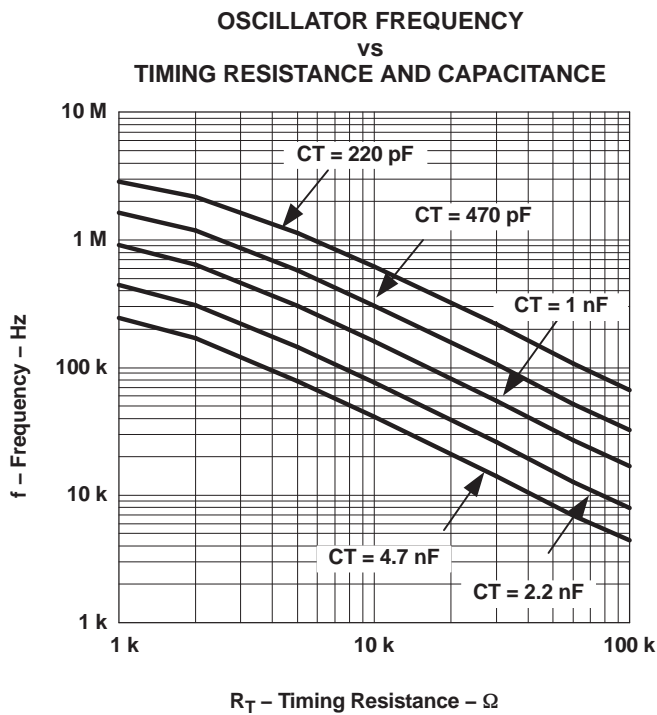

Figure 6.

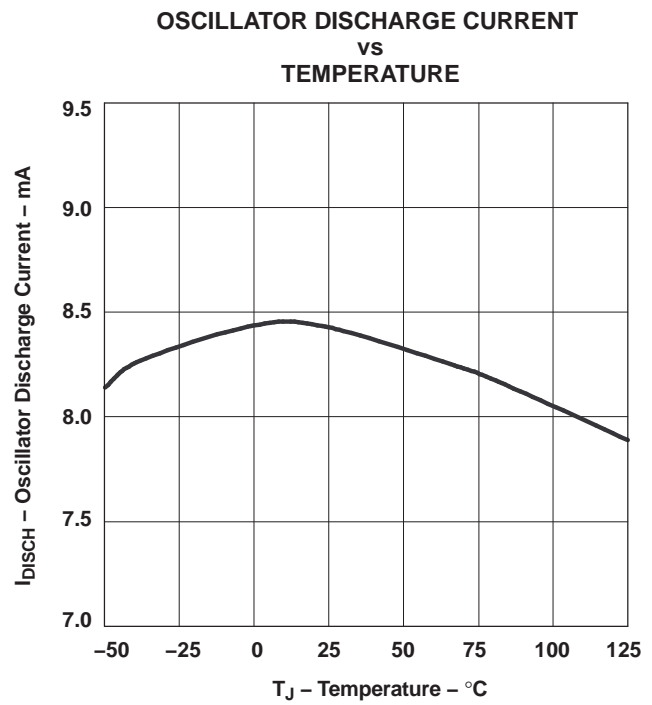

Figure 7.

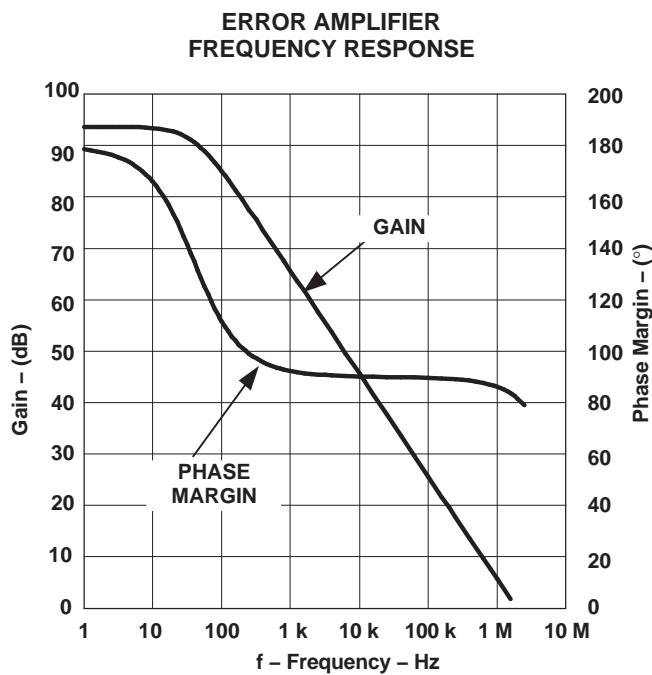

Figure 8.

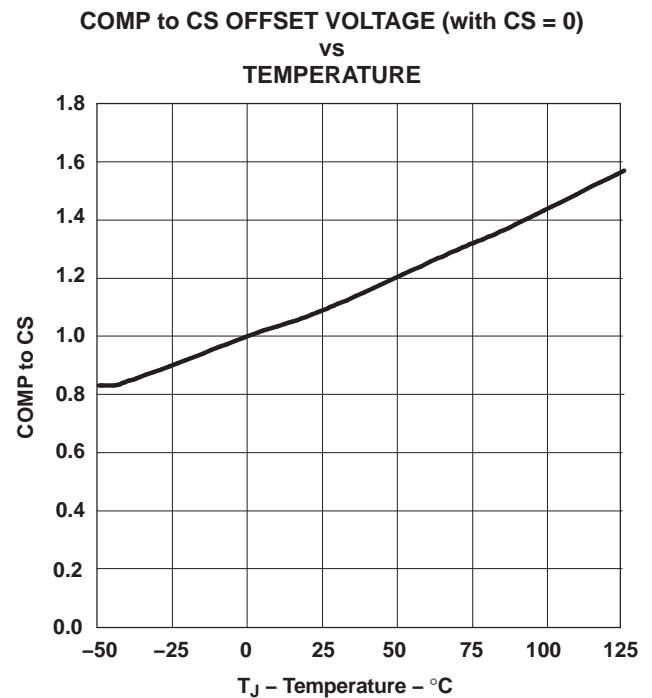

Figure 9.

APPLICATION INFORMATION (continued)

**REFERENCE VOLTAGE
 VS
 TEMPERATURE**

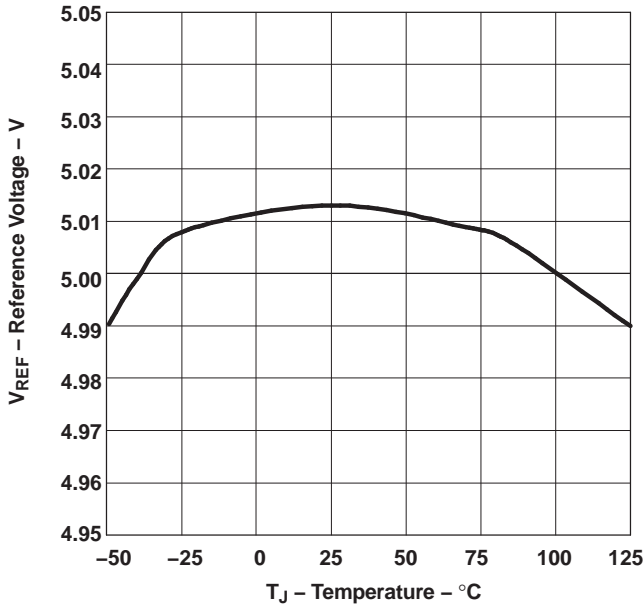

Figure 10.

**ERROR AMPLIFIER REFERENCE VOLTAGE
 VS
 TEMPERATURE**

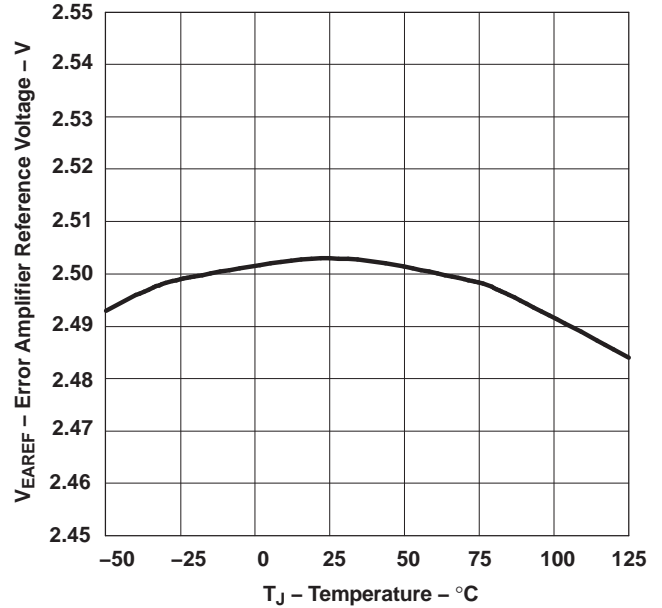

Figure 11.

**REFERENCE SHORT-CIRCUIT CURRENT
 VS
 TEMPERATURE**

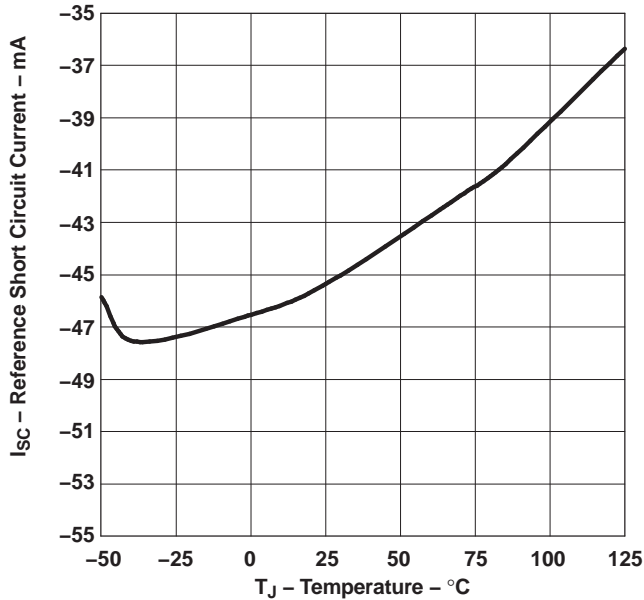

Figure 12.

**ERROR AMPLIFIER INPUT BIAS CURRENT
 VS
 TEMPERATURE**

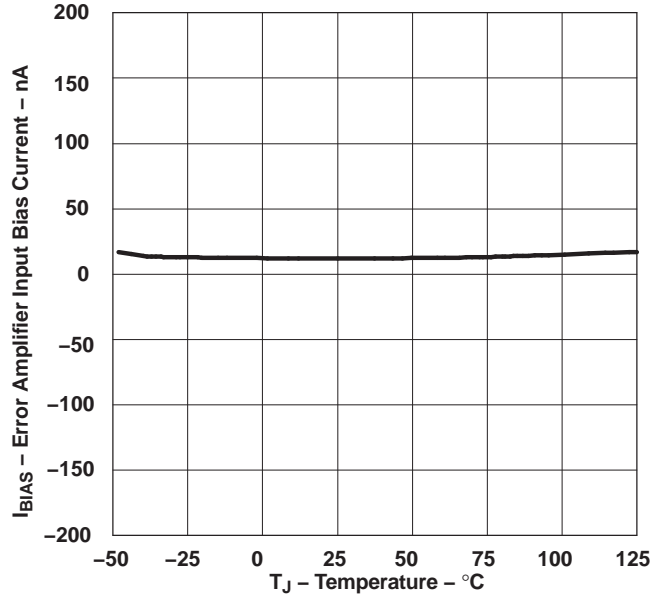

Figure 13.

APPLICATION INFORMATION (continued)

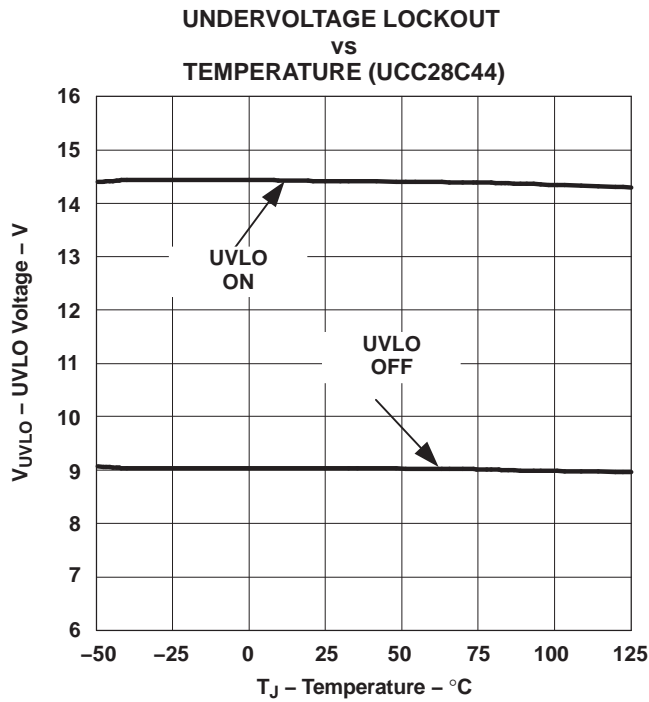

Figure 14.

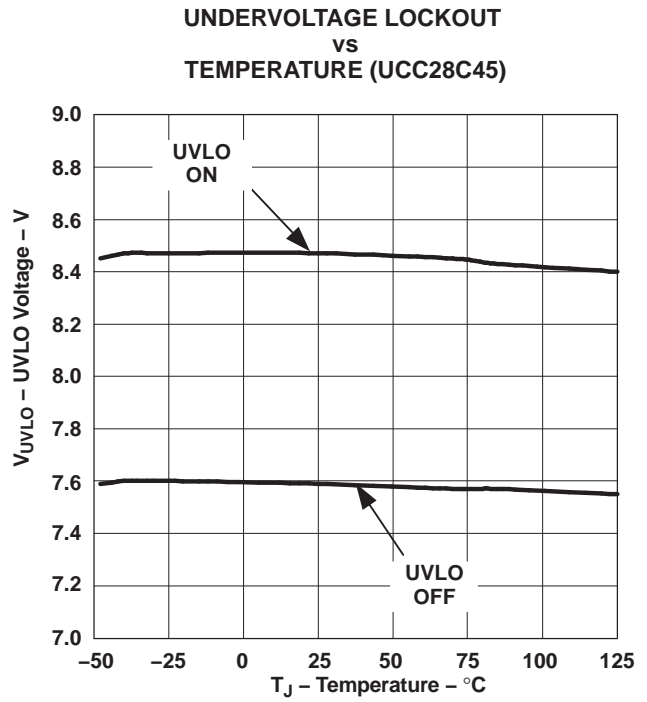

Figure 15.

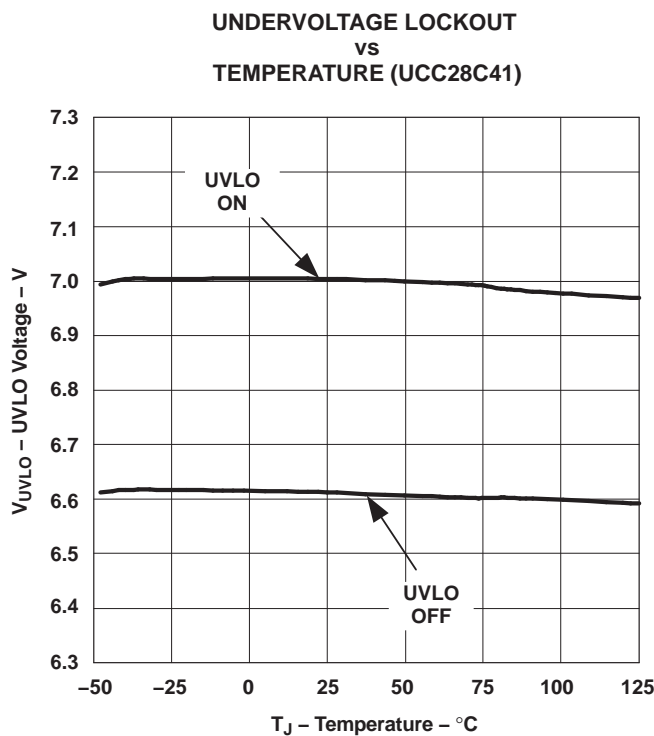

Figure 16.

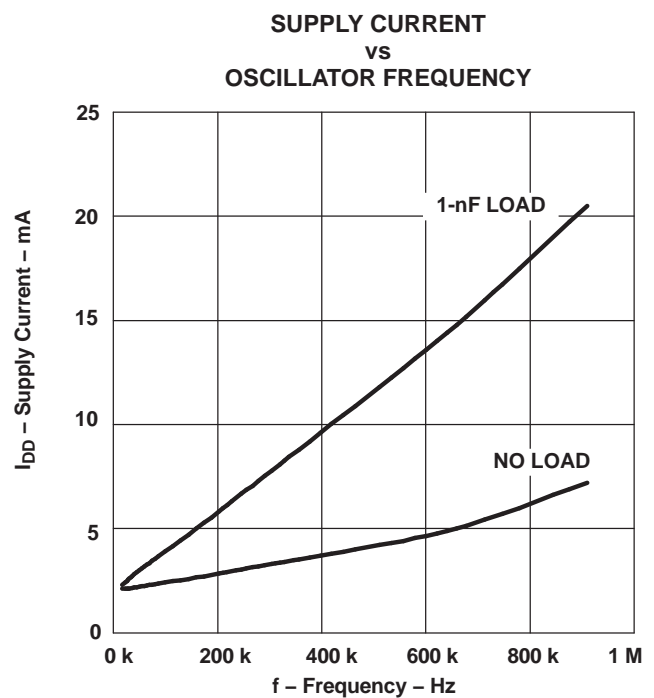

Figure 17.

APPLICATION INFORMATION (continued)

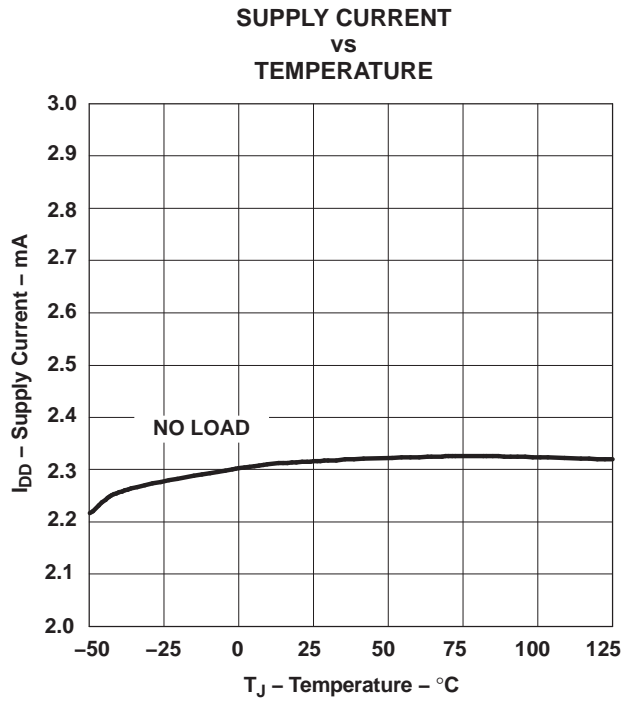

Figure 18.

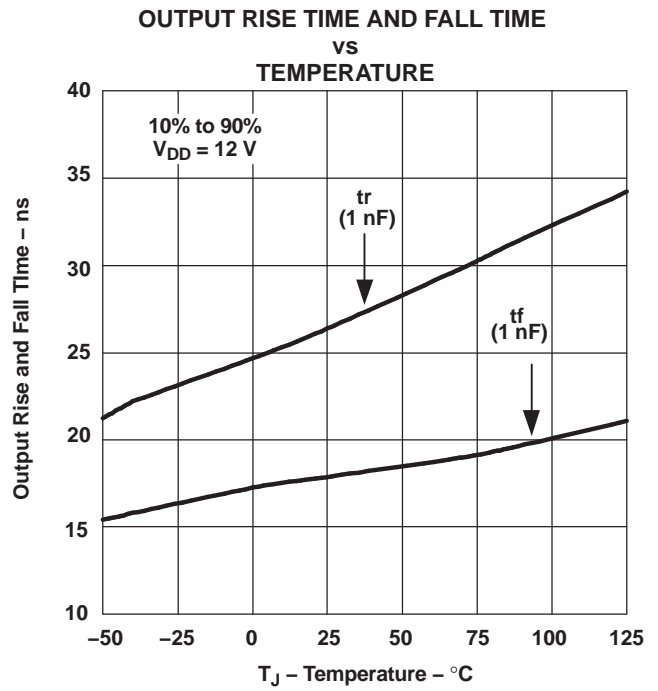

Figure 19.

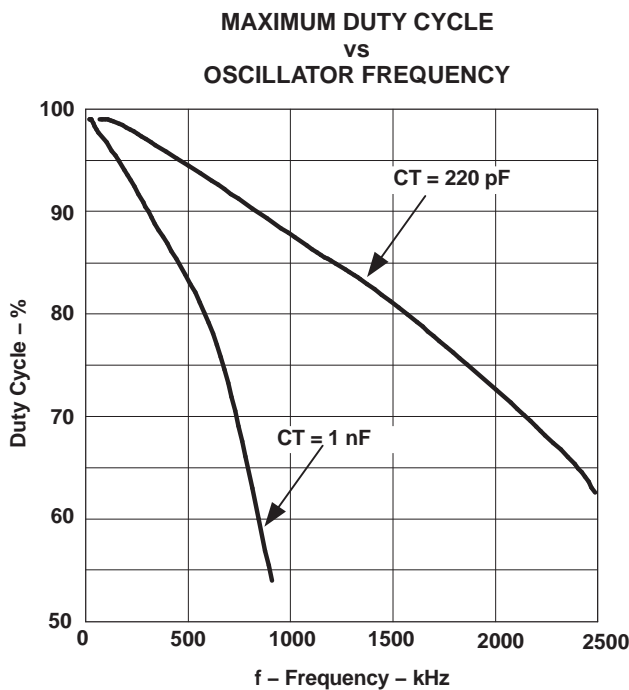

Figure 20.

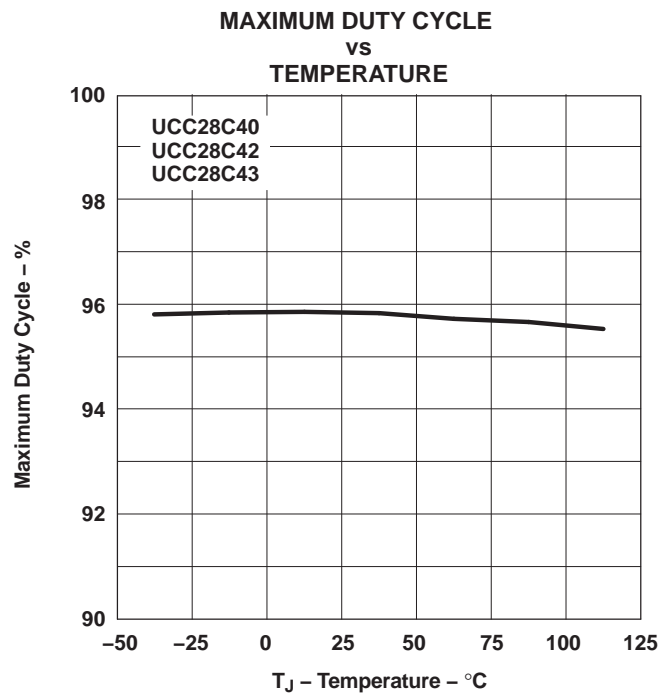

Figure 21.

APPLICATION INFORMATION (continued)

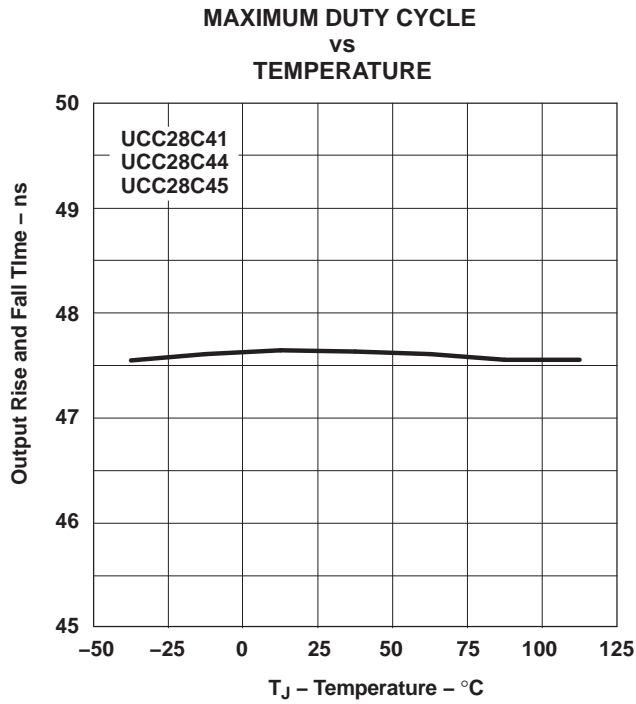

Figure 22.

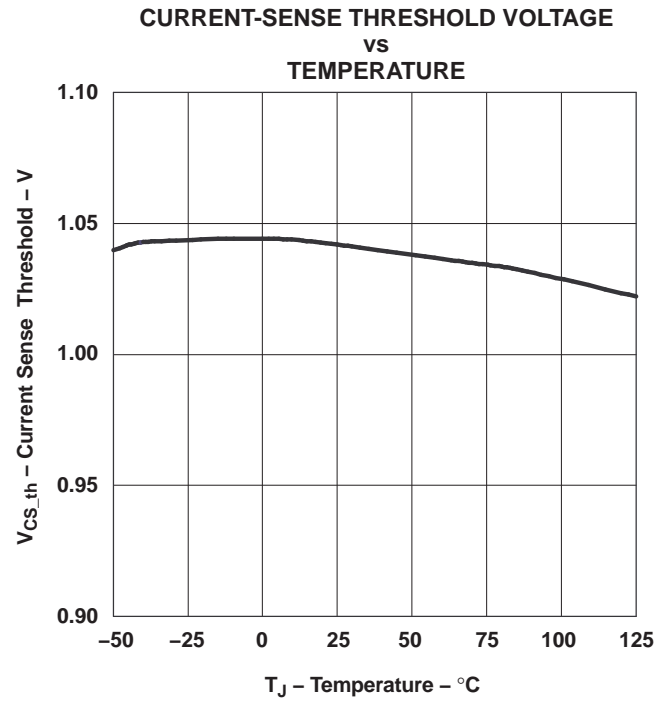

Figure 23.

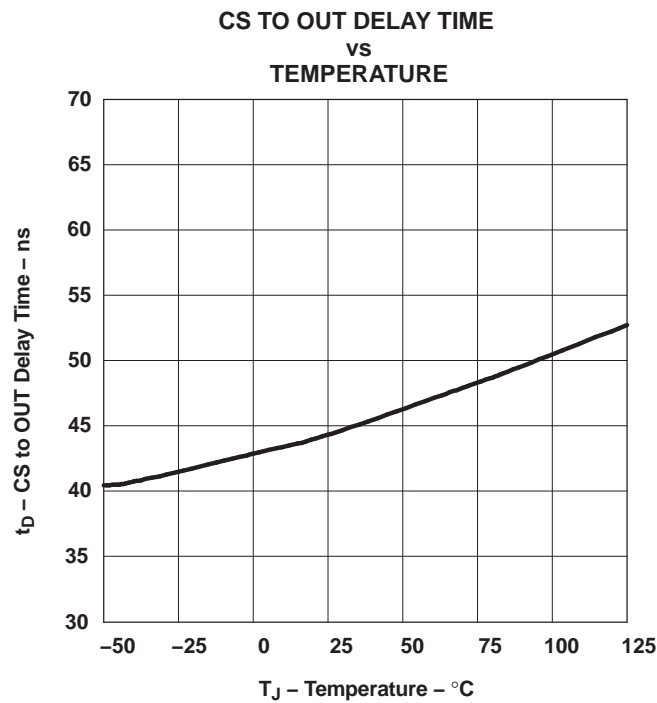

Figure 24.

PACKAGING INFORMATION

Orderable part number	Status (1)	Material type (2)	Package Pins	Package qty Carrier	RoHS (3)	Lead finish/ Ball material (4)	MSL rating/ Peak reflow (5)	Op temp (°C)	Part marking (6)
UCC28C43MDREP	NRND	Production	SOIC (D) 8	2500 LARGE T&R	Yes	NIPDAU	Level-1-260C-UNLIM	-55 to 125	EAAM
UCC28C43MDREP.A	NRND	Production	SOIC (D) 8	2500 LARGE T&R	Yes	NIPDAU	Level-1-260C-UNLIM	-55 to 125	EAAM
UCC28C45MDREP	NRND	Production	SOIC (D) 8	2500 LARGE T&R	Yes	NIPDAU	Level-1-260C-UNLIM	-55 to 125	EABM
UCC28C45MDREP.A	NRND	Production	SOIC (D) 8	2500 LARGE T&R	Yes	NIPDAU	Level-1-260C-UNLIM	-55 to 125	EABM
V62/07615-01XE	NRND	Production	SOIC (D) 8	2500 LARGE T&R	Yes	NIPDAU	Level-1-260C-UNLIM	-55 to 125	EAAM
V62/07615-02XE	NRND	Production	SOIC (D) 8	2500 LARGE T&R	Yes	NIPDAU	Level-1-260C-UNLIM	-55 to 125	EABM

(1) **Status:** For more details on status, see our [product life cycle](#).

(2) **Material type:** When designated, preproduction parts are prototypes/experimental devices, and are not yet approved or released for full production. Testing and final process, including without limitation quality assurance, reliability performance testing, and/or process qualification, may not yet be complete, and this item is subject to further changes or possible discontinuation. If available for ordering, purchases will be subject to an additional waiver at checkout, and are intended for early internal evaluation purposes only. These items are sold without warranties of any kind.

(3) **RoHS values:** Yes, No, RoHS Exempt. See the [TI RoHS Statement](#) for additional information and value definition.

(4) **Lead finish/Ball material:** Parts may have multiple material finish options. Finish options are separated by a vertical ruled line. Lead finish/Ball material values may wrap to two lines if the finish value exceeds the maximum column width.

(5) **MSL rating/Peak reflow:** The moisture sensitivity level ratings and peak solder (reflow) temperatures. In the event that a part has multiple moisture sensitivity ratings, only the lowest level per JEDEC standards is shown. Refer to the shipping label for the actual reflow temperature that will be used to mount the part to the printed circuit board.

(6) **Part marking:** There may be an additional marking, which relates to the logo, the lot trace code information, or the environmental category of the part.

Multiple part markings will be inside parentheses. Only one part marking contained in parentheses and separated by a "~" will appear on a part. If a line is indented then it is a continuation of the previous line and the two combined represent the entire part marking for that device.

Important Information and Disclaimer:The information provided on this page represents TI's knowledge and belief as of the date that it is provided. TI bases its knowledge and belief on information provided by third parties, and makes no representation or warranty as to the accuracy of such information. Efforts are underway to better integrate information from third parties. TI has taken and continues to take reasonable steps to provide representative and accurate information but may not have conducted destructive testing or chemical analysis on incoming materials and chemicals. TI and TI suppliers consider certain information to be proprietary, and thus CAS numbers and other limited information may not be available for release.

In no event shall TI's liability arising out of such information exceed the total purchase price of the TI part(s) at issue in this document sold by TI to Customer on an annual basis.

OTHER QUALIFIED VERSIONS OF UCC28C43-EP, UCC28C45-EP :

- Catalog : [UCC28C43](#), [UCC28C45](#)
- Automotive : [UCC28C43-Q1](#), [UCC28C45-Q1](#)

NOTE: Qualified Version Definitions:

- Catalog - TI's standard catalog product
- Automotive - Q100 devices qualified for high-reliability automotive applications targeting zero defects

TAPE AND REEL INFORMATION

QUADRANT ASSIGNMENTS FOR PIN 1 ORIENTATION IN TAPE

*All dimensions are nominal

Device	Package Type	Package Drawing	Pins	SPQ	Reel Diameter (mm)	Reel Width W1 (mm)	A0 (mm)	B0 (mm)	K0 (mm)	P1 (mm)	W (mm)	Pin1 Quadrant
UCC28C43MDREP	SOIC	D	8	2500	330.0	12.4	6.4	5.2	2.1	8.0	12.0	Q1
UCC28C45MDREP	SOIC	D	8	2500	330.0	12.4	6.4	5.2	2.1	8.0	12.0	Q1

TAPE AND REEL BOX DIMENSIONS

*All dimensions are nominal

Device	Package Type	Package Drawing	Pins	SPQ	Length (mm)	Width (mm)	Height (mm)
UCC28C43MDREP	SOIC	D	8	2500	340.5	338.1	20.6
UCC28C45MDREP	SOIC	D	8	2500	353.0	353.0	32.0



D0008A

PACKAGE OUTLINE

SOIC - 1.75 mm max height

SMALL OUTLINE INTEGRATED CIRCUIT



4214825/C 02/2019

NOTES:

1. Linear dimensions are in inches [millimeters]. Dimensions in parenthesis are for reference only. Controlling dimensions are in inches. Dimensioning and tolerancing per ASME Y14.5M.
2. This drawing is subject to change without notice.
3. This dimension does not include mold flash, protrusions, or gate burrs. Mold flash, protrusions, or gate burrs shall not exceed $.006$ [0.15] per side.
4. This dimension does not include interlead flash.
5. Reference JEDEC registration MS-012, variation AA.

EXAMPLE BOARD LAYOUT

D0008A

SOIC - 1.75 mm max height

SMALL OUTLINE INTEGRATED CIRCUIT



LAND PATTERN EXAMPLE
 EXPOSED METAL SHOWN
 SCALE:8X



SOLDER MASK DETAILS

4214825/C 02/2019

NOTES: (continued)

- 6. Publication IPC-7351 may have alternate designs.
- 7. Solder mask tolerances between and around signal pads can vary based on board fabrication site.

EXAMPLE STENCIL DESIGN

D0008A

SOIC - 1.75 mm max height

SMALL OUTLINE INTEGRATED CIRCUIT



SOLDER PASTE EXAMPLE
BASED ON .005 INCH [0.125 MM] THICK STENCIL
SCALE:8X

4214825/C 02/2019

NOTES: (continued)

8. Laser cutting apertures with trapezoidal walls and rounded corners may offer better paste release. IPC-7525 may have alternate design recommendations.
9. Board assembly site may have different recommendations for stencil design.

IMPORTANT NOTICE AND DISCLAIMER

TI PROVIDES TECHNICAL AND RELIABILITY DATA (INCLUDING DATASHEETS), DESIGN RESOURCES (INCLUDING REFERENCE DESIGNS), APPLICATION OR OTHER DESIGN ADVICE, WEB TOOLS, SAFETY INFORMATION, AND OTHER RESOURCES "AS IS" AND WITH ALL FAULTS, AND DISCLAIMS ALL WARRANTIES, EXPRESS AND IMPLIED, INCLUDING WITHOUT LIMITATION ANY IMPLIED WARRANTIES OF MERCHANTABILITY, FITNESS FOR A PARTICULAR PURPOSE OR NON-INFRINGEMENT OF THIRD PARTY INTELLECTUAL PROPERTY RIGHTS.

These resources are intended for skilled developers designing with TI products. You are solely responsible for (1) selecting the appropriate TI products for your application, (2) designing, validating and testing your application, and (3) ensuring your application meets applicable standards, and any other safety, security, regulatory or other requirements.

These resources are subject to change without notice. TI grants you permission to use these resources only for development of an application that uses the TI products described in the resource. Other reproduction and display of these resources is prohibited. No license is granted to any other TI intellectual property right or to any third party intellectual property right. TI disclaims responsibility for, and you fully indemnify TI and its representatives against any claims, damages, costs, losses, and liabilities arising out of your use of these resources.

TI's products are provided subject to [TI's Terms of Sale](#), [TI's General Quality Guidelines](#), or other applicable terms available either on [ti.com](#) or provided in conjunction with such TI products. TI's provision of these resources does not expand or otherwise alter TI's applicable warranties or warranty disclaimers for TI products. Unless TI explicitly designates a product as custom or customer-specified, TI products are standard, catalog, general purpose devices.

TI objects to and rejects any additional or different terms you may propose.

Copyright © 2026, Texas Instruments Incorporated

Last updated 10/2025