

# SimpleLink™ Wi-Fi® CC3000 Module

Self-contained Wi-Fi solution enables easy-to-implement Internet connectivity



## Overview

TI continues to advance Wi-Fi technology solutions for the Internet of Things (IoT) with the enhancement of the self-contained SimpleLink CC3000 module. The CC3000 features enhanced software designed to dramatically simplify design and development of connected devices while advancing the user experience. It is an ideal solution for developers of health and fitness, home automation, smart metering, security and safety applications.

To support connected devices in the IoT, the cloud-enabled CC3000 has multiple options for cloud solutions. One example is the Exosite IoT cloud platform, which provides cloud server access for remote sensor data monitoring and control through the Internet. TI's SimpleLink CC3000 users receive free service for one CC3000 device when registering at the Exosite web site.

[http://processors.wiki.ti.com/index.php/CC3000\\_and\\_Exosite](http://processors.wiki.ti.com/index.php/CC3000_and_Exosite)

The CC3000 is a certified module by TI that reduces development time, lowers manufacturing costs, saves board space and minimizes RF expertise required. Additionally, it is provided as a complete platform solution including software drivers, sample applications, API guide, user documentation and a world-class support community.

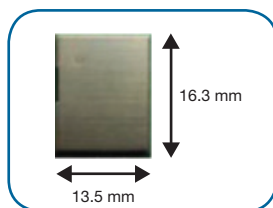

TI CC3000 module shown.

## Key Features and Benefits

- Wireless network processor
  - IEEE 802.11 b/g
  - Embedded IPv4 TCP/IP stack
- Best-in-class radio performance
  - Tx power: +18dBm, 11Mbps
  - Rx sensitivity: -88dBm, 11Mbps
- Single power supply 2.7V to 4.8V
- Pair with low-MIPS, low-cost MCUs with compact memory footprint
- FCC/IC/CE/TELEC certified reference design with chip antenna
- Small form factor module
  - 16.3mm × 13.5mm × 2mm
- Temperature range -20°C to +70°C
- SmartConfig™ technology enables simple Wi-Fi configuration using a smartphone, tablet or PC
- Proven Wi-Fi interoperability based on TI's seventh generation Wi-Fi solution
- Complete platform solution including user and porting guides, API guide, sample applications and support community

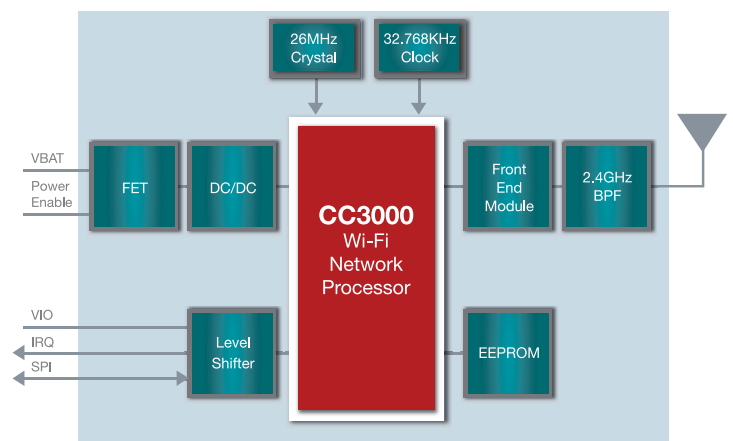

CC3000 module diagram.

## Development Tools and Software





### CC3000EM

The CC3000 Evaluation Module (EM) board aids evaluation and development. The EM board contains the CC3000 module and standard RF1 and RF2 headers that allow the user to connect to many microcontroller (MCU) platforms such as TI's ultra-low power MSP430™ MCU and Tiva™ C Series MCUs Experimenter board.

Additionally, these evaluation modules are offered with a complete reference design that can be copy and pasted directly into your design. See our Wiki for these details: <http://processors.wiki.ti.com/index.php/CC3000>

### CC3000BOOST

This board, called a BoosterPack, aids in the evaluation and development of CC3000 solutions. It contains the CC3000 module and standard BoosterPack headers that connect to TI's low-cost LaunchPad evaluation kits that feature TI's MCU portfolio. [www.ti.com/launchpad](http://www.ti.com/launchpad)

Individual/Bundled Kits	Kit Contents	Order
 <p><b>CC3000 Evaluation Module (CC3000EM)</b></p>	<ul style="list-style-type: none"> <li>1 TI CC3000 Evaluation Module</li> <li>Compatible Experimenter boards (sold separately): MSP-EXP430F5529, MSP-EXP430FR5739, TM4C123G</li> </ul>	<p>\$35.00 USD</p> <p>Available at TI eStore and TI distributors</p>
 <p><b>CC3000 BoosterPack (CC3000BOOST)</b></p> <p>See Board Tour Video User Guide</p>	<ul style="list-style-type: none"> <li>1 TI CC3000 BoosterPack</li> <li>Compatible LaunchPads (sold separately) – MSP-EXP430G2, EK-TM4C123GXPL</li> </ul>	<p>\$35.00 USD</p> <p>Available at TI eStore and TI distributors</p>
 <p><b>SimpleLink CC3000 BoosterPack and MSP430 LaunchPad Bundle (MSP-EXP430G2-CC3000BOOST)</b></p>	<ul style="list-style-type: none"> <li>Soft bundle               <ul style="list-style-type: none"> <li>– 1 CC3000 BoosterPack</li> <li>– 1 MSP-EXP430G2 LaunchPad</li> </ul> </li> </ul>	<p>\$40.99 USD</p> <p>Available at TI eStore only</p>
 <p><b>SimpleLink CC3000 BoosterPack and Tiva™ C Series LaunchPad EK-TM4C123GXL-CC3000BOOST</b></p>	<ul style="list-style-type: none"> <li>Soft bundle               <ul style="list-style-type: none"> <li>– 1 CC3000 BoosterPack</li> <li>– 1 EK-TM4C123GXL LaunchPad</li> </ul> </li> </ul>	<p>\$43.99 USD</p> <p>Available at TI eStore only</p>
 <p><b>SimpleLink CC3000 Evaluation Module and MSP-EXP430FR5739 Experimenter Board Bundle (MSP-EXP430FR5739-CC3000EM)</b></p>	<ul style="list-style-type: none"> <li>Soft bundle               <ul style="list-style-type: none"> <li>– 1 CC3000 EM board</li> <li>– 1 MSP-EXP430FR5739 Experimenter board</li> </ul> </li> </ul>	<p>\$57.00 USD</p> <p>Available at TI eStore only</p>

### TI's SimpleLink™ software and tools

TI's SimpleLink CC3000 Wi-Fi® module is a self-contained wireless network processor that simplifies the implementation of Internet connectivity for a seamless Wi-Fi design process. The CC3000 provides complete platform solutions including SmartConfig™ technology, one-step set-up and with the tool (Patch Programmer) to update driver and firmware patches, and single SDK with drivers and sample applications such as **home automation**, **Internet time** and **email** among others. These applications will help shorten the design process and give you a greater range of options for end-use cases.

### Applications

- Home automation
- Home security
- Connected appliances
- Smart energy
- M2M communication

### TI's SimpleLink quick configuration tool

To create a quicker user experience, TI has created Smart-Config technology – a one-step and one-time process to connect a CC3000-enabled device to the home wireless network. This greatly stands apart from other Wi-Fi configuration solutions that require multiple steps to configure a device onto the network. [www.ti.com/tool/smartconfig](http://www.ti.com/tool/smartconfig)

### TI's SimpleLink CC3000 Patch Programmer

TI provides the Patch Program Service Pack to distribute fixes to CC3000. The TI released Service Pack is burned into the CC3000 EEPROM using CC3000 Host Driver APIs.

### CC3000 Resources

- Learn more at: [www.ti.com/cc3000](http://www.ti.com/cc3000)
- E2E™ Forum: [www.ti.com/wiconforum](http://www.ti.com/wiconforum)
- Wireless Connectivity Wiki: [www.ti.com/cc3000wiki](http://www.ti.com/cc3000wiki)

The platform bar, E2E, MSP430, SimpleLink, SmartConfig and Tiva are trademarks of Texas Instruments. All other trademarks are the property of their respective owners.

## IMPORTANT NOTICE

Texas Instruments Incorporated and its subsidiaries (TI) reserve the right to make corrections, enhancements, improvements and other changes to its semiconductor products and services per JESD46, latest issue, and to discontinue any product or service per JESD48, latest issue. Buyers should obtain the latest relevant information before placing orders and should verify that such information is current and complete. All semiconductor products (also referred to herein as "components") are sold subject to TI's terms and conditions of sale supplied at the time of order acknowledgment.

TI warrants performance of its components to the specifications applicable at the time of sale, in accordance with the warranty in TI's terms and conditions of sale of semiconductor products. Testing and other quality control techniques are used to the extent TI deems necessary to support this warranty. Except where mandated by applicable law, testing of all parameters of each component is not necessarily performed.

TI assumes no liability for applications assistance or the design of Buyers' products. Buyers are responsible for their products and applications using TI components. To minimize the risks associated with Buyers' products and applications, Buyers should provide adequate design and operating safeguards.

TI does not warrant or represent that any license, either express or implied, is granted under any patent right, copyright, mask work right, or other intellectual property right relating to any combination, machine, or process in which TI components or services are used. Information published by TI regarding third-party products or services does not constitute a license to use such products or services or a warranty or endorsement thereof. Use of such information may require a license from a third party under the patents or other intellectual property of the third party, or a license from TI under the patents or other intellectual property of TI.

Reproduction of significant portions of TI information in TI data books or data sheets is permissible only if reproduction is without alteration and is accompanied by all associated warranties, conditions, limitations, and notices. TI is not responsible or liable for such altered documentation. Information of third parties may be subject to additional restrictions.

Resale of TI components or services with statements different from or beyond the parameters stated by TI for that component or service voids all express and any implied warranties for the associated TI component or service and is an unfair and deceptive business practice. TI is not responsible or liable for any such statements.

Buyer acknowledges and agrees that it is solely responsible for compliance with all legal, regulatory and safety-related requirements concerning its products, and any use of TI components in its applications, notwithstanding any applications-related information or support that may be provided by TI. Buyer represents and agrees that it has all the necessary expertise to create and implement safeguards which anticipate dangerous consequences of failures, monitor failures and their consequences, lessen the likelihood of failures that might cause harm and take appropriate remedial actions. Buyer will fully indemnify TI and its representatives against any damages arising out of the use of any TI components in safety-critical applications.

In some cases, TI components may be promoted specifically to facilitate safety-related applications. With such components, TI's goal is to help enable customers to design and create their own end-product solutions that meet applicable functional safety standards and requirements. Nonetheless, such components are subject to these terms.

No TI components are authorized for use in FDA Class III (or similar life-critical medical equipment) unless authorized officers of the parties have executed a special agreement specifically governing such use.

Only those TI components which TI has specifically designated as military grade or "enhanced plastic" are designed and intended for use in military/aerospace applications or environments. Buyer acknowledges and agrees that any military or aerospace use of TI components which have **not** been so designated is solely at the Buyer's risk, and that Buyer is solely responsible for compliance with all legal and regulatory requirements in connection with such use.

TI has specifically designated certain components as meeting ISO/TS16949 requirements, mainly for automotive use. In any case of use of non-designated products, TI will not be responsible for any failure to meet ISO/TS16949.

### Products

Audio	<a href="http://www.ti.com/audio">www.ti.com/audio</a>
Amplifiers	<a href="http://amplifier.ti.com">amplifier.ti.com</a>
Data Converters	<a href="http://dataconverter.ti.com">dataconverter.ti.com</a>
DLP® Products	<a href="http://www.dlp.com">www.dlp.com</a>
DSP	<a href="http://dsp.ti.com">dsp.ti.com</a>
Clocks and Timers	<a href="http://www.ti.com/clocks">www.ti.com/clocks</a>
Interface	<a href="http://interface.ti.com">interface.ti.com</a>
Logic	<a href="http://logic.ti.com">logic.ti.com</a>
Power Mgmt	<a href="http://power.ti.com">power.ti.com</a>
Microcontrollers	<a href="http://microcontroller.ti.com">microcontroller.ti.com</a>
RFID	<a href="http://www.ti-rfid.com">www.ti-rfid.com</a>
OMAP Applications Processors	<a href="http://www.ti.com/omap">www.ti.com/omap</a>
Wireless Connectivity	<a href="http://www.ti.com/wirelessconnectivity">www.ti.com/wirelessconnectivity</a>

### Applications

Automotive and Transportation	<a href="http://www.ti.com/automotive">www.ti.com/automotive</a>
Communications and Telecom	<a href="http://www.ti.com/communications">www.ti.com/communications</a>
Computers and Peripherals	<a href="http://www.ti.com/computers">www.ti.com/computers</a>
Consumer Electronics	<a href="http://www.ti.com/consumer-apps">www.ti.com/consumer-apps</a>
Energy and Lighting	<a href="http://www.ti.com/energy">www.ti.com/energy</a>
Industrial	<a href="http://www.ti.com/industrial">www.ti.com/industrial</a>
Medical	<a href="http://www.ti.com/medical">www.ti.com/medical</a>
Security	<a href="http://www.ti.com/security">www.ti.com/security</a>
Space, Avionics and Defense	<a href="http://www.ti.com/space-avionics-defense">www.ti.com/space-avionics-defense</a>
Video and Imaging	<a href="http://www.ti.com/video">www.ti.com/video</a>

### TI E2E Community

[e2e.ti.com](http://e2e.ti.com)