

DLPC4430 DLP® Display Controller

1 Features

- Single DLP controller support for up to WUXGA resolution display using digital micromirror devices (DMDs):
 - Up to 1920 × 1200 at 120 Hz (2D and 3D)
- Provides single 30-bit or dual 60-bit input pixel interface:
 - RGB data format
 - 8, 9, or 10 bits per color
 - Pixel clock up to 320 MHz in dual 30-bit mode on a single controller
- High-speed, low voltage differential signaling (LVDS) DMD interface
- 150-MHz ARM946™ microprocessor
- Microprocessor peripherals
 - Programmable pulse-width modulation (PWM) and capture timers
 - Three I²C ports, three UART ports and three SSP ports
 - One USB 1.1 secondary port
- Image processing
 - Multiple image processing algorithms
 - Frame rate conversion
 - Color coordinate adjustment
 - Programmable color space conversion
 - Programmable degamma and splash
 - Integrated support for 3-D display
 - 2-D keystone correction

- Integrated clock generation circuitry
 - Operates on a single 20-MHz crystal
 - Integrated spread spectrum clocking
- External memory support
 - Parallel flash for microprocessor and PWM sequence
- 516-pin plastic ball grid array package
- Supports LED and laser hybrid illuminations

2 Applications

- [Laser TV](#)
- [Smart projector](#)
- [Digital signage](#)
- [Enterprise projectors](#)

3 Description

The DLPC4430 is a digital display controller for the DLP® display chipset. The chipset comprises the DLPC4430 display controller, the DLP digital micromirror device (DMD), the DLPA100 controller power management device, and the DLPA300 DMD micromirror driver (refer to the DMD data sheet). This solution is a great fit for display systems that require high resolution, high brightness, and system simplicity. To ensure reliable operation, the DLPC4430 display controller must always be used with a DLP DMD and respective DLP power management devices.

Device Information

PART NUMBER ⁽¹⁾	PACKAGE	BODY SIZE (NOM)
DLPC4430	ZPC (516)	27.00 mm × 27.00 mm

(1) For all available packages, see the orderable addendum at the end of the data sheet.

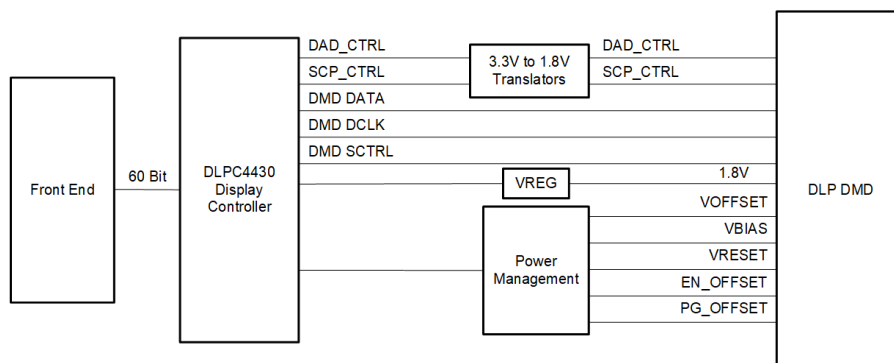

Simplified Schematic



Table of Contents

1 Features	1	7 Detailed Description	25
2 Applications	1	7.1 Overview.....	25
3 Description	1	7.2 Functional Block Diagram.....	25
4 Revision History	2	7.3 Feature Description.....	25
5 Pin Configuration and Functions	3	7.4 Device Functional Modes.....	28
6 Specifications	13	8 Application and Implementation	30
6.1 Absolute Maximum Ratings.....	13	8.1 Application Information.....	30
6.2 ESD Ratings.....	13	8.2 Typical Application.....	30
6.3 Recommended Operating Conditions.....	13	9 Power Supply Recommendations	33
6.4 Thermal Information.....	14	9.1 System Power Regulations.....	33
6.5 Electrical Characteristics.....	14	9.2 System Power-Up Sequence.....	33
6.6 System Oscillators Timing Requirements.....	17	9.3 Power-On Sense (POSENSE) Support.....	33
6.7 Test and Reset Timing Requirements.....	17	9.4 System Environment and Defaults.....	34
6.8 JTAG Interface: I/O Boundary Scan Application Timing Requirements.....	18	10 Layout	35
6.9 Port 1 Input Pixel Timing Requirements.....	18	10.1 Layout Guidelines.....	35
6.10 Port 3 Input Pixel Interface (via GPIO) Timing Requirements.....	19	11 Device and Documentation Support	41
6.11 DMD LVDS Interface Timing Requirements.....	20	11.1 Third-Party Products Disclaimer.....	41
6.12 Synchronous Serial Port (SSP) Interface Timing Requirements.....	20	11.2 Device Support.....	41
6.13 Programmable Output Clocks Switching Characteristics.....	21	11.3 Documentation Support.....	43
6.14 Synchronous Serial Port Interface (SSP) Switching Characteristics.....	21	11.4 Receiving Notification of Documentation Updates..	44
6.15 JTAG Interface: I/O Boundary Scan Application Switching Characteristics.....	22	11.5 Support Resources.....	44
		11.6 Trademarks.....	44
		11.7 Electrostatic Discharge Caution.....	44
		11.8 Glossary.....	44
		12 Mechanical, Packaging, and Orderable Information	45

4 Revision History

NOTE: Page numbers for previous revisions may differ from page numbers in the current version.

Changes from Revision * (December 2021) to Revision A (February 2023)	Page
• Updated wording in Features for clarity	1
• Updated Description	1
• Updated Device Nomenclature and Device Marking sections	43

5 Pin Configuration and Functions

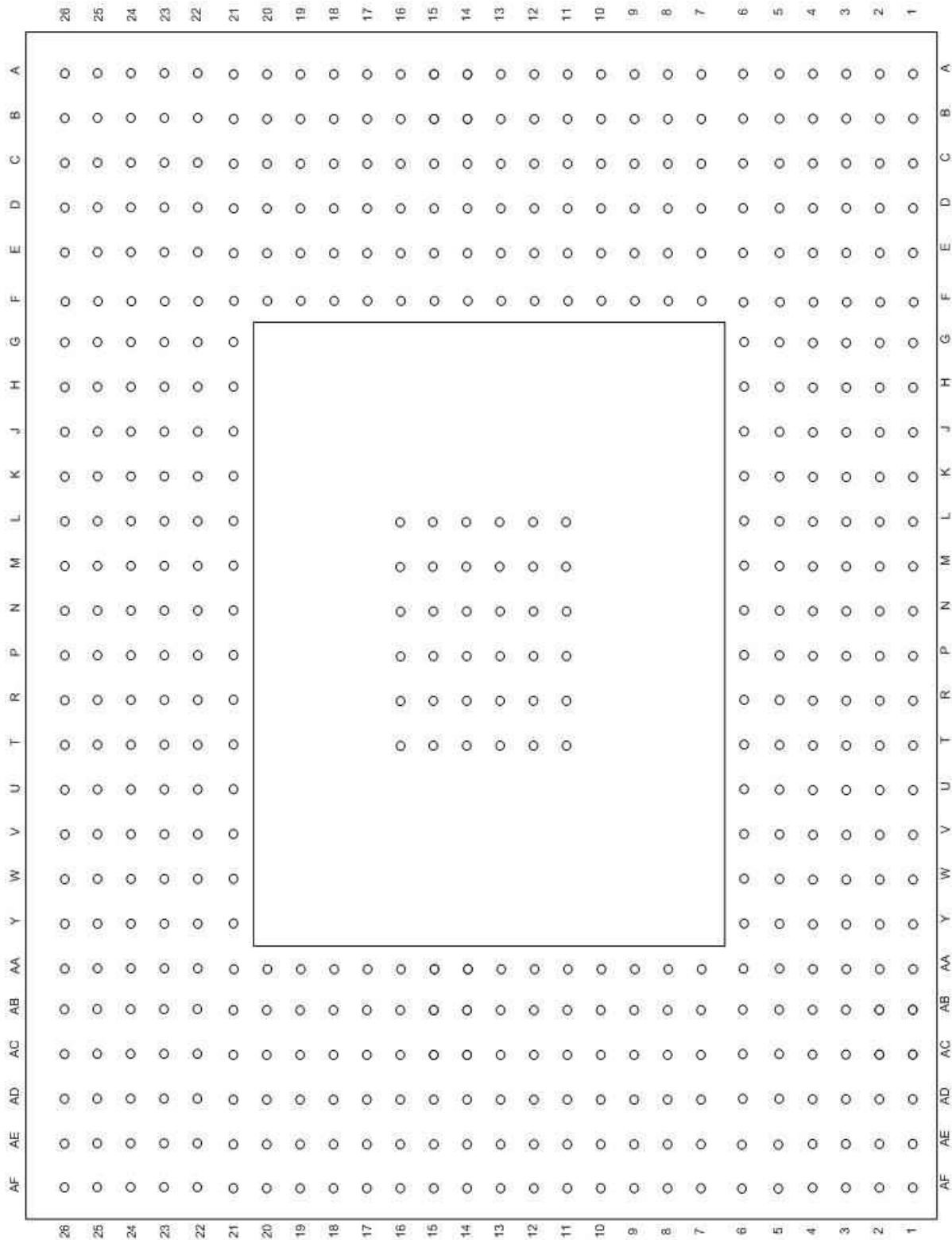

Table 5-1. Pin Functions

PIN ⁽¹⁾		TYPE ⁽²⁾	DESCRIPTION
NAME	NO.		
POSENSE	P22	I ₄	Power-on sense, high true, signal provided from an external voltage monitor circuit. This signal is driven active (high) when all ASIC supply voltages have reached 90% of their specified minimum voltage. This signal is driven inactive (low) after the falling edge of PWRGOOD as specified.
PWRGOOD	T26	I ₄	Power good, high true, signal from external power supply or voltage monitor. A high value indicates all power is within operating voltage specs and the system is safe to exit its reset state. A transition from high to low is used to indicate that the controller or DMD supply voltage drops below their rated minimum level. This transition must occur prior to the supply voltage drop as specified. During this interval, PPOSENSE must remain active high. This is a warning of an imminent power loss condition. This warning is required to enhance long term DMD reliability. A DMD park followed by a full controller reset is performed by the DLPC4430 controller when PWRGOOD goes low for the specified minimum, protecting the DMD. This minimum deassertion time is used to protect the input from glitches. Following this the DLPC4430 controller is held in its reset state as long as PWRGOOD is low. PWRGOOD must be driven high for normal operation. The DLPC4430 controller acknowledges PWRGOOD as active once it has been driven high for a specified minimum time. Uses hysteresis
EXT_ARTZ	T24	O ₂	General purpose, low true, reset output. This output is asserted low immediately upon asserting power-up reset (POSENSE) low and remains low while PPOSENSE remains low. EXT_ARSTZ continues to be held low after the release of power-up reset (that is, PPOSENSE set high) until released by software. EXT_ARSTZ is also asserted low approximately 5 μs after the detection of a PWRGOOD or any internally generated reset. In all cases it remains active for a minimum of 2 ms. Note that the ASIC contains a software register that can be used to independently drive this output.
MTR_ARTZ	T25	O ₂	Color wheel motor controller, low true, reset output. This output is asserted low immediately upon asserting power-up reset (POSENSE) low and remains low while PPOSENSE remains low. MTR_ARSTZ continues to be held low after the release of power-up reset (that is, PPOSENSE is set high) until released by software. MTR_ARSTZ is also optionally asserted low approximately 5 μs after the detection of a PWRGOOD or any internally generated reset. In all cases, it remains active for a minimum of 2 ms. Note that the ASIC contains a software register that can be used to independently drive this output. The ASIC also contains a software register that can be used to disable the assertion of motor reset upon a lamp strike reset.
BOARD LEVEL TEST AND INITIALIZATION ⁽³⁾			
TDI	N25	I ₄	JTAG serial data in
TCK	N24	I ₄	JTAG serial data clock
TMS1	P25	I ₄	JTAG test mode select
TMS2	P26	I ₄	JTAG test mode select
TDO1	N23	O ₅	JTAG serial data out
TDO2	N22	O ₅	JTAG serial data out
TRSTZ	M23	I ₄	JTAG reset. This signal includes an internal pullup and utilizes hysteresis. This pin is pulled high (or left unconnected) when the JTAG interface is in use for boundary scan or ARM debug. Connect this pin to ground otherwise. Failure to tie this pin low during normal operation causes startup and initialization problems.
RTCK	E4	O ₂	JTAG return clock
ETM_PIPESTAT_2	A4	B ₂	ETM trace port pipeline status. Indicates the pipeline status of the ARM core. These signals include internal pulldowns.
ETM_PIPESTAT_1	B5	B ₂	
ETM_PIPESTAT_0	C6	B ₂	
ETM_TRACESYNC	A5	B ₂	ETM trace port synchronization signal, indicating the start of a branch sequence on the trace packet port. This signal includes an internal pulldown.
ETM_TRACECLK	D7	B ₂	ETM trace port clock. This signal includes an internal pulldown.
ICTSEN	M24	I ₄	IC tristate enable (active high). Asserting high tristates all outputs except the JTAG interface. This signal includes an internal pulldown, however an external pulldown is recommended for added protection. Uses hysteresis.
TSTPT_7	E8	B ₂	Test pin 7. This signal provides internal pulldowns. Normal use: reserved for test output. Recommended to be left open or unconnected for normal use
TSTPT_6	B4	B ₂	Test pin 6. This signal provides internal pulldowns. Normal use: reserved for test output. Recommended to be left open or unconnected for normal use
TSTPT_5	C4	B ₂	Test pin 5. This signal provides internal pulldowns. Normal use: reserved for test output. Recommended to be left open or unconnected for normal use
TSTPT_4	E7	B ₂	Test pin 4. This signal provides internal pulldowns. Normal use: reserved for test output. Recommended to be left open or unconnected for normal use
TSTPT_3	D5	B ₂	Test pin 3. This signal provides internal pulldowns. Normal use: reserved for test output. Recommended to be left open or unconnected for normal use.
TSTPT_2	E6	B ₂	Test pin 2. This signal provides internal pulldowns. Additionally, it is recommended that jumper options be provided for connecting TSTPT(2:0) to external pullups.
TSTPT_1	D3	B ₂	Test pin 1. This signal provides internal pulldowns. Additionally, it is recommended that jumper options be provided for connecting TSTPT(2:0) to external pullups.
TSTPT_0	C2	B ₂	Test pin 0. This signal provides internal pulldowns. Additionally, it is recommended that jumper options be provided for connecting TSTPT(2:0) to external pullups.
DEVICE TEST			
HW_TEST_EN	M25	I ₄	Device manufacturing test enable. This signal includes an internal pulldown and utilizes hysteresis. It is recommended that this signal be tied to an external ground in normal operation for added protection.
PORT1 and PORT 2 CHANNEL DATA and CONTROL ^{(4) (5) (6) (7)}			
P_CLK1	AE22	I ₄	Input Port Data Pixel Write Clock (selectable as rising or falling edge triggered, and which port it is associated with (A or B or (A and B))). This signal includes an internal pulldown.

Table 5-1. Pin Functions (continued)

PIN ⁽¹⁾		TYPE ⁽²⁾	DESCRIPTION
NAME	NO.		
P_CLK2	W25	I ₄	Input Port Data Pixel Write Clock (selectable as rising or falling edge triggered, and which port it is associated with (A or B or (A and B))). This signal includes an internal pulldown.
P_CLK3	AF23	I ₄	Input Port Data Pixel Write Clock (selectable as rising or falling edge triggered, and which port it is associated with (A or B or (A and B))). This signal includes an internal pulldown.
P_DATAEN1	AF22	I ₄	Active High Data Enable. Selectable as to which port it is associated with (A or B or (A and B)). This signal includes an internal pulldown.
P_DATAEN2	W24	I ₄	Active High Data Enable. Selectable as to which port it is associated with (A or B or (A and B)). This signal includes an internal pulldown.
P1_A_9	AD15	I ₄	Port 1 A Channel Input Pixel Data (bit weight 128)
P1_A_8	AE15	I ₄	Port 1 A Channel Input Pixel Data (bit weight 64)
P1_A_7	AE14	I ₄	Port 1 A Channel Input Pixel Data (bit weight 32)
P1_A_6	AE13	I ₄	Port 1 A Channel Input Pixel Data (bit weight 16)
P1_A_5	AD13	I ₄	Port 1 A Channel Input Pixel Data (bit weight 8)
P1_A_4	AC13	I ₄	Port 1 A Channel Input Pixel Data (bit weight 4)
P1_A_3	AF14	I ₄	Port 1 A Channel Input Pixel Data (bit weight 2)
P1_A_2	AF13	I ₄	Port 1 A Channel Input Pixel Data (bit weight 1)
P1_A_1	AF12	I ₄	Port 1 A Channel Input Pixel Data (bit weight 0.5)
P1_A_0	AE12	I ₄	Port 1 A Channel Input Pixel Data (bit weight 0.25)
P1_B_9	AF18	I ₄	Port 1 B Channel Input Pixel Data (bit weight 128)
P1_B_8	AB18	I ₄	Port 1 B Channel Input Pixel Data (bit weight 64)
P1_B_7	AC15	I ₄	Port 1 B Channel Input Pixel Data (bit weight 32)
P1_B_6	AC16	I ₄	Port 1 B Channel Input Pixel Data (bit weight 16)
P1_B_5	AD16	I ₄	Port 1 B Channel Input Pixel Data (bit weight 8)
P1_B_4	AE16	I ₄	Port 1 B Channel Input Pixel Data (bit weight 4)
P1_B_3	AF16	I ₄	Port 1 B Channel Input Pixel Data (bit weight 2)
P1_B_2	AF15	I ₄	Port 1 B Channel Input Pixel Data (bit weight 1)
P1_B_1	AC14	I ₄	Port 1 B Channel Input Pixel Data (bit weight 0.5)
P1_B_0	AD14	I ₄	Port 1 B Channel Input Pixel Data (bit weight 0.25)
P1_C_9	AD20	I ₄	Port 1 C Channel Input Pixel Data (bit weight 128)
P1_C_8	AE20	I ₄	Port 1 C Channel Input Pixel Data (bit weight 64)
P1_C_7	AE21	I ₄	Port 1 C Channel Input Pixel Data (bit weight 32)
P1_C_6	AF21	I ₄	Port 1 C Channel Input Pixel Data (bit weight 16)
P1_C_5	AD19	I ₄	Port 1 C Channel Input Pixel Data (bit weight 8)
P1_C_4	AE19	I ₄	Port 1 C Channel Input Pixel Data (bit weight 4)
P1_C_3	AF19	I ₄	Port 1 C Channel Input Pixel Data (bit weight 2)
P1_C_2	AF20	I ₄	Port 1 C Channel Input Pixel Data (bit weight 1)
P1_C_1	AC19	I ₄	Port 1 C Channel Input Pixel Data (bit weight 0.5)
P1_C_0	AE19	I ₄	Port 1 C Channel Input Pixel Data (bit weight 0.25)
P1_VSYNC	AC20	B ₂	Port 1 Vertical Sync. This signal includes an internal pulldown. While intended to be associated with Port 1, it can be programmed for use with Port 2.
P1_HSYNC	AD21	B ₂	Port 1 Horizontal Sync. This signal includes an internal pulldown. While intended to be associated with Port 1, it can be programmed for use with Port 2.
P2_A_9	AD26	I ₄	Port 2 A Channel Input Pixel Data (bit weight 128)
P2_A_8	AD25	I ₄	Port 2 A Channel Input Pixel Data (bit weight 64)
P2_A_7	AB21	I ₄	Port 2 A Channel Input Pixel Data (bit weight 32)
P2_A_6	AC22	I ₄	Port 2 A Channel Input Pixel Data (bit weight 16)
P2_A_5	AD23	I ₄	Port 1 A Channel Input Pixel Data (bit weight 8)
P2_A_4	AB20	I ₄	Port 2 A Channel Input Pixel Data (bit weight 4)
P2_A_3	AC21	I ₄	Port 2 A Channel Input Pixel Data (bit weight 2)
P2_A_2	AD22	I ₄	Port 2 A Channel Input Pixel Data (bit weight 1)
P2_A_1	AE23	I ₄	Port 2 A Channel Input Pixel Data (bit weight 0.5)
P2_A_0	AB19	I ₄	Port 2 A Channel Input Pixel Data (bit weight 0.25)
P2_B_9	Y22	I ₄	Port 2 B Channel Input Pixel Data (bit weight 128)
P2_B_8	AB26	I ₄	Port 2 B Channel Input Pixel Data (bit weight 64)
P2_B_7	AA23	I ₄	Port 2 B Channel Input Pixel Data (bit weight 32)
P2_B_6	AB25	I ₄	Port 2 B Channel Input Pixel Data (bit weight 16)

Table 5-1. Pin Functions (continued)

PIN ⁽¹⁾		TYPE ⁽²⁾	DESCRIPTION
NAME	NO.		
P2_B_5	AA22	I ₄	Port 2 B Channel Input Pixel Data (bit weight 8)
P2_B_4	AB24	I ₄	Port 2 B Channel Input Pixel Data (bit weight 4)
P2_B_3	AC26	I ₄	Port 2 B Channel Input Pixel Data (bit weight 2)
P2_B_2	AB23	I ₄	Port 2 B Channel Input Pixel Data (bit weight 1)
P2_B_1	AC25	I ₄	Port 2 B Channel Input Pixel Data (bit weight 0.5)
P2_B_0	AC24	I ₄	Port 2 B Channel Input Pixel Data (bit weight 0.25)
P2_C_9	W23	I ₄	Port 2 C Channel Input Pixel Data (bit weight 128)
P2_C_8	V22	I ₄	Port 2 B Channel Input Pixel Data (bit weight 64)
P2_C_7	Y26	I ₄	Port 2 C Channel Input Pixel Data (bit weight 32)
P2_C_6	Y25	I ₄	Port 2 B Channel Input Pixel Data (bit weight 16)
P2_C_5	Y24	I ₄	Port 2 C Channel Input Pixel Data (bit weight 8)
P2_C_4	Y23	I ₄	Port 2 B Channel Input Pixel Data (bit weight 4)
P2_C_3	W22	I ₄	Port 2 C Channel Input Pixel Data (bit weight 2)
P2_C_2	AA26	I ₄	Port 2 B Channel Input Pixel Data (bit weight 1)
P2_C_1	AA25	I ₄	Port 2 C Channel Input Pixel Data (bit weight 0.5)
P2_C_0	AA24	I ₄	Port 2 B Channel Input Pixel Data (bit weight 0.25)
P2_VSYNC	U22	B ₂	Port 2 Vertical Sync. This signal includes an internal pulldown. While intended to be associated with Port 2, it can be programmed for use with Port 1.
P2_HSYNC	W26	B ₂	Port 2 Horizontal Sync. This signal includes an internal pulldown. While intended to be associated with Port 2, it can be programmed for use with Port 1.
ALF INPUT PORT CONTROL			
ALF_VSYNC	AF11	I ₄	Autolock dedicated vertical sync. This signal includes an internal pulldown and uses hysteresis.
ALF_HSYNC	AD11	I ₄	Autolock dedicated horizontal sync. This signal includes an internal pulldown and uses hysteresis.
ALF_CS	AE11	I ₄	Autolock dedicated composite sync (sync on green). This signal includes an internal pulldown and uses hysteresis.
DMD RESET and BIAS CONTROL			
DADOEZ	AE7	O ₅	DAD (DLPA200 / DLPA300) Output Enable (active low)
DADADDR_3	AD6	O ₅	DAD address
DADADDR_2	AE5	O ₅	
DADADDR_1	AF4	O ₅	
DADADDR_0	AB8	O ₅	
DADMODE_1	AD7	O ₅	DAD modes
DADMODE_0	AE6	O ₅	
DADSEL_1	AE4	O ₅	DAD select
DADSEL_0	AC7	O ₅	
DADSTRB	AF5	O ₅	DAD strobe
DAD_INTZ	AC8	I ₄	DAD interrupt (active low). This signal typically requires an external pullup and uses hysteresis.
DMD LVDS INTERFACE			
DCKA_P	V4	O ₇	DMD, LVDS I/F channel A, differential clock
DCKA_N	V3	O ₇	
SCA_P	V2	O ₇	DMD, LVDS I/F channel A, differential serial control
SCA_N	V1	O ₇	
DDA_P_15	P4	O ₇	DMD, LVDS I/F channel A, differential serial data
DDA_N_15	P3	O ₇	DMD, LVDS I/F channel A, differential serial data
DDA_P_14	P2	O ₇	DMD, LVDS I/F channel A, differential serial data
DDA_N_14	P1	O ₇	DMD, LVDS I/F channel A, differential serial data
DDA_N_12	R1	O ₇	DMD, LVDS I/F channel A, differential serial data
DDA_P_11	T4	O ₇	DMD, LVDS I/F channel A, differential serial data
DDA_N_11	T3	O ₇	DMD, LVDS I/F channel A, differential serial data
DDA_P_10	T2	O ₇	DMD, LVDS I/F channel A, differential serial data
DDA_N_10	T1	O ₇	DMD, LVDS I/F channel A, differential serial data
DDA_P_9	U4	O ₇	DMD, LVDS I/F channel A, differential serial data
DDA_N_9	U3	O ₇	DMD, LVDS I/F channel A, differential serial data
DDA_P_8	U2	O ₇	DMD, LVDS I/F channel A, differential serial data
DDA_N_8	U1	O ₇	DMD, LVDS I/F channel A, differential serial data
DDA_P_7	W4	O ₇	DMD, LVDS I/F channel A, differential serial data

Table 5-1. Pin Functions (continued)

PIN ⁽¹⁾		TYPE ⁽²⁾	DESCRIPTION
NAME	NO.		
DDA_N_7	W3	O ₇	DMD, LVDS I/F channel A, differential serial data
DDA_P_6	W2	O ₇	DMD, LVDS I/F channel A, differential serial data
DDA_N_6	W1	O ₇	DMD, LVDS I/F channel A, differential serial data
DDA_P_5	Y2	O ₇	DMD, LVDS I/F channel A, differential serial data
DDA_N_5	Y1	O ₇	DMD, LVDS I/F channel A, differential serial data
DDA_P_4	Y4	O ₇	DMD, LVDS I/F channel A, differential serial data
DDA_N_4	Y3	O ₇	DMD, LVDS I/F channel A, differential serial data
DDA_P_3	AA2	O ₇	DMD, LVDS I/F channel A, differential serial data
DDA_N_3	AA1	O ₇	DMD, LVDS I/F channel A, differential serial data
DDA_P_2	AA4	O ₇	DMD, LVDS I/F channel A, differential serial data
DDA_N_2	AA3	O ₇	DMD, LVDS I/F channel A, differential serial data
DDA_P_1	AB2	O ₇	DMD, LVDS I/F channel A, differential serial data
DDA_N_1	AB1	O ₇	DMD, LVDS I/F channel A, differential serial data
DDA_P_0	AC2	O ₇	DMD, LVDS I/F channel A, differential serial data
DDA_N_0	AC1	O ₇	DMD, LVDS I/F channel A, differential serial data
DCKB_P	J3	O ₇	DMD, LVDS I/F channel A, differential clock
DCKB_N	J4	O ₇	DMD, LVDS I/F channel A, differential clock
SCB_P	J1	O ₇	DMD, LVDS I/F channel A, differential serial control
SCB_N	J2	O ₇	DMD, LVDS I/F channel A, differential serial control
DDB_P_15	N1	O ₇	DMD, LVDS I/F channel B, differential serial data
DDB_N_15	N2	O ₇	DMD, LVDS I/F channel B, differential serial data
DDB_P_14	N3	O ₇	DMD, LVDS I/F channel B, differential serial data
DDB_N_14	N4	O ₇	DMD, LVDS I/F channel B, differential serial data
DDB_P_13	M2	O ₇	DMD, LVDS I/F channel B, differential serial data
DDB_N_13	M1	O ₇	DMD, LVDS I/F channel B, differential serial data
DDB_P_12	M3	O ₇	DMD, LVDS I/F channel B, differential serial data
DDB_N_12	M4	O ₇	DMD, LVDS I/F channel B, differential serial data
DDB_P_11	L1	O ₇	DMD, LVDS I/F channel B, differential serial data
DDB_N_11	L2	O ₇	DMD, LVDS I/F channel B, differential serial data
DDB_P_10	L3	O ₇	DMD, LVDS I/F channel B, differential serial data
DDB_N_10	L4	O ₇	DMD, LVDS I/F channel B, differential serial data
DDB_P_9	K1	O ₇	DMD, LVDS I/F channel B, differential serial data
DDB_N_9	K2	O ₇	DMD, LVDS I/F channel B, differential serial data
DDB_P_8	K3	O ₇	DMD, LVDS I/F channel B, differential serial data
DDB_N_8	K4	O ₇	DMD, LVDS I/F channel B, differential serial data
DDB_P_7	H1	O ₇	DMD, LVDS I/F channel B, differential serial data
DDB_N_7	H2	O ₇	DMD, LVDS I/F channel B, differential serial data
DDB_P_6	H3	O ₇	DMD, LVDS I/F channel B, differential serial data
DDB_N_6	H4	O ₇	DMD, LVDS I/F channel B, differential serial data
DDB_P_5	G1	O ₇	DMD, LVDS I/F channel B, differential serial data
DDB_N_5	G2	O ₇	DMD, LVDS I/F channel B, differential serial data
DDB_P_4	G3	O ₇	DMD, LVDS I/F channel B, differential serial data
DDB_N_4	G4	O ₇	DMD, LVDS I/F channel B, differential serial data
DDB_P_3	F1	O ₇	DMD, LVDS I/F channel B, differential serial data
DDB_N_3	F2	O ₇	DMD, LVDS I/F channel B, differential serial data
DDB_P_2	F3	O ₇	DMD, LVDS I/F channel B, differential serial data
DDB_N_2	F4	O ₇	DMD, LVDS I/F channel B, differential serial data
DDB_P_1	E1	O ₇	DMD, LVDS I/F channel B, differential serial data
DDB_N_1	E2	O ₇	DMD, LVDS I/F channel B, differential serial data
DDB_P_0	D1	O ₇	DMD, LVDS I/F channel B, differential serial data
DDB_N_0	D2	O ₇	DMD, LVDS I/F channel B, differential serial data
PROGRAM MEMORY (Flash and SRAM) INTERFACE			
PM_CSZ_0	D13	O ₅	Input Bus D Data bit 3. 100-Ω internal LVDS termination

Table 5-1. Pin Functions (continued)

PIN ⁽¹⁾		TYPE ⁽²⁾	DESCRIPTION
NAME	NO.		
PM_CSZ_1	E12	O ₅	
PM_CSZ_2	A13	O ₅	Input Bus D Data bit 5. 100-Ω internal LVDS termination
PM_ADDR_22 (GPIO 36)	A12	B ₅	
PM_ADDR_21 (GPIO 35)	E11	B ₅	Input Bus D Data bit 10. 100-Ω internal LVDS termination
PM_ADDR_20	D12	O ₅	
PM_ADDR_19	C12	O ₅	Input Bus D Data bit 11. 100-Ω internal LVDS termination
PM_ADDR_18	B11	O ₅	
PM_ADDR_17	A11	O ₅	Input Bus D Data bit 12. 100-Ω internal LVDS termination
PM_ADDR_16	D11	O ₅	
PM_ADDR_15	C11	O ₅	Input Bus D Data bit 13. 100-Ω internal LVDS termination
PM_ADDR_14	E10	O ₅	
PM_ADDR_13	D10	O ₅	Input Bus D Data bit 14. 100-Ω internal LVDS termination
PM_ADDR_12	C10	O ₅	
PM_ADDR_11	B9	O ₅	Input Bus D Data bit 15. 100-Ω internal LVDS termination
PM_ADDR_10	A9	O ₅	
PM_ADDR_9	E9	O ₅	Output Bus A Data bit 0 to DMD
PM_ADDR_8	D9	O ₅	
PM_ADDR_7	C9	O ₅	Output Bus A Data bit 1 to DMD
PM_ADDR_6	B8	O ₅	
PM_ADDR_5	A8	O ₅	Output Bus A Data bit 2 to DMD
PM_ADDR_4	D8	O ₅	
PM_ADDR_3	C8	O ₅	Output Bus A Data bit 3 to DMD
PM_ADDR_2	B7	O ₅	
PM_ADDR_1	A7	O ₅	Output Bus A Data bit 4 to DMD
PM_ADDR_0	C7	O ₅	
PM_WEZ	B12	O ₅	Output Bus A Data bit 5 to DMD
PM_OEZ	C13	O ₅	
PM_BLSZ_1	B6	O ₅	Output Bus A Data bit 6 to DMD
PM_BLSZ_0	A6	O ₅	
PM_DATA_15	C17	B ₅	Output Bus A Data bit 7 to DMD
PM_DATA_14	B16	B ₅	
PM_DATA_13	A16	B ₅	Output Bus A Data bit 8 to DMD
PM_DATA_12	A15	B ₅	
PM_DATA_11	B15	B ₅	Output Bus A Data bit 9 to DMD
PM_DATA_10	D16	B ₅	
PM_DATA_9	C16	B ₅	Output Bus A Data bit 10 to DMD
PM_DATA_8	E14	B ₅	
PM_DATA_7	D15	B ₅	Output Bus A Data bit 11 to DMD
PM_DATA_6	C15	B ₅	
PM_DATA_5	B14	B ₅	Output Bus A Data bit 12 to DMD
PM_DATA_4	A14	B ₅	
PM_DATA_3	E13	B ₅	Output Bus A Data bit 13 to DMD
PM_DATA_2	D14	B ₅	
PM_DATA_1	C14	B ₅	Output Bus A Data bit 14 to DMD
PM_DATA_0	B13	B ₅	
PERIPHERAL INTERFACE			
IIC0_SCL	A10	B ₈	I2C Bus 0, Clock. This bus support 400 kHz, fast mode operation. This signal requires an external pullup to 3.3 V. The minimum acceptable pullup value is 1 kΩ. This input is not 5-V tolerant.
IIC0_SDA	B10	B ₈	2C Bus 0, Data. This bus support 400 kHz, fast mode operation. This signal requires an external pullup to 3.3 V. The minimum acceptable pullup value is 1 kΩ. This input is not 5-V tolerant.
SSP0_CLK	AD4	B ₅	Synchronous Serial Port 0, clock
SSP0_RXD	AD5	I ₄	Synchronous Serial Port 0, receive data in

Table 5-1. Pin Functions (continued)

PIN ⁽¹⁾		TYPE ⁽²⁾	DESCRIPTION	
NAME	NO.			
SSP0_TXD	AB7	O ₅	Synchronous Serial Port 0, transmit data out	
SSP0_CSZ_0	AC5	B ₅	Synchronous Serial Port 0, chip select 0 (active low)	
SSP0_CSZ_1	AB6	B ₅	Synchronous Serial Port 0, chip select 1 (active low)	
SSP0_CSZ_2	AC3	B ₅	Synchronous Serial Port 0, chip select 2 (active low)	
UART0_TXD	AB3	O ₅	UART0 transmit data output	
UART0_RXD	AD1	O ₅	UART0 receive data input	
UART0_RTSZ	AD2	O ₅	UART0 ready to send hardware flow control output (active low)	
UART0_CTSZ	AE2	I ₄	UART0 clear to send hardware flow control input (active low)	
USB_DAT_N	C5	B ₉	USB D- I/O	
USB_DAT_P	D6	B ₉	USB D+ I/O	
PMD_INTZ	AE8	I ₄	Interrupt from DLPA100 (active low). This signal requires an external pullup. Uses hysteresis	
CW_PWM	AD8	O ₅	Color wheel control PWM output	
CW_INDEX	AF7	O ₅	Color wheel index. Uses hysteresis	
GENERAL PURPOSE I/O (GPIO) ⁽⁸⁾			ALTERNATE FUNCTION 1	ALTERNATE FUNCTION 2
GPIO_82	E3	B ₅	N/A	N/A
GPIO_81	AB10	B ₂	Reserved	N/A
GPIO_80	AD9	B ₂	IR_ENABLE (O)	N/A
GPIO_79	AE9	B ₂	Reserved	N/A
GPIO_78	AF9	B ₂	FIELD_3D_LR (I)	N/A
GPIO_77	AB11	B ₂	SAS_INTGTR_EN (O)	SENSE_PWM_OUT (O)
GPIO_76	AC10	B ₂	SAS_CSZ (O)	N/A
GPIO_75	AD10	B ₂	SAS_DO (O)	SENSE_FREQ_IN (I)
GPIO_74	AE10	B ₂	SAS_DI (I)	SENSE_COMP_IN (I)
GPIO_73	AF10	B ₂	SAS_CLK (O)	N/A
GPIO_72	K24	B ₂	SSP2_DI (I)	N/A
GPIO_71	K23	B ₂	SSP2_CLK (B)	N/A
GPIO_70	K22	B ₂	SSP2_CSZ_1 (B)	N/A
GPIO_69	J26	B ₂	SSP2_CSZ_0 (B)	N/A
GPIO_68	J25	B ₂	SSP2_DO (O)	N/A
GPIO_67	J24	B ₂	SP_Data_7 (O)	SSP2_CSZ_2 (B)
GPIO_66	J23	B ₂	SP_Data_6 (O)	SSP0_CSZ_5 (B)
GPIO_65	J22	B ₂	SP_Data_5 (O)	N/A
GPIO_64	H26	B ₂	SP_Data_4 (O)	CW_PWM_2 (O)
GPIO_63	H25	B ₂	SP_Data_3 (O)	CW_INDEX_2 (I)
GPIO_62	H24	B ₂	SP_Data_2 (O)	SP_VC_FDBK (I)
GPIO_61	H23	B ₂	SP_Data_1 (O)	N/A
GPIO_60	H22	B ₂	SP_Data_0 (O)	N/A
GPIO_59	G26	B ₂	SP_WG_CLK (O)	N/A
GPIO_58	G25	B ₂	LED_SENSE_PULSE (O)	N/A
GPIO_57	F25	B ₂	Reserved	N/A
GPIO_56	G24	B ₂	UART2_RXD (O)	N/A
GPIO_55	G23	B ₂	UART2_TXD (O)	N/A
GPIO_54	F26	B ₂	PROG_AUX_7 (O)	N/A
GPIO_53	E26	B ₂	PROG_AUX_6 (O)	N/A
GPIO_52	AB12	B ₂	CSP_Data (O)	ALF_CLAMP (O)
GPIO_51	AC11	B ₂	CSP_CLK (O)	ALF_COAST (O)
GPIO_50	V23	B ₂	Reserved	HBT_CLKOUT (O)
GPIO_49	V24	B ₂	Reserved	HBT_DO (O)
GPIO_48	V25	B ₂	Reserved	HBT_CLKIN_2 (I)
GPIO_47	V26	B ₂	Reserved	HBT_DI_2 (I)
GPIO_46	T22	B ₂	Reserved	HBT_CLKIN_1 (I)
GPIO_45	U23	B ₂	Reserved	HBT_DI_1 (I)
GPIO_44	U24	B ₂	Reserved	HBT_CLKIN_0 (I)
GPIO_43	U25	B ₂	Reserved	HBT_DI_0 (I)

Table 5-1. Pin Functions (continued)

PIN ⁽¹⁾		TYPE ⁽²⁾	DESCRIPTION	
NAME	NO.			
GPIO_42	U26	B ₂	Reserved	SSP0_CSZ4 (B)
GPIO_41	R22	B ₂	Reserved	DASYNC (I)
GPIO_40	T23	B ₂	Reserved	FSD12 (O)
GPIO_39	F24	B ₂	SW reserved (Boot Hold)	SW reserved (Boot Hold)
GPIO_38	E25	B ₂	SW reserved (USB Enumeration Enable)	SW reserved (USB Enumeration Enable)
GPIO_37	G22	B ₂	N/A	N/A
GPIO_36	A12	B ₂	PM_ADDR_22 (O)	I2C_2 SDA (B)
GPIO_35	E11	B ₂	PM_ADDR_21 (O)	I2C_2 SCL (B)
GPIO_34	F23	B ₂	SSP1_CSZ_1 (B)	N/A
GPIO_33	D26	B ₂	SSP1_CSZ_0 (B)	N/A
GPIO_32	E24	B ₂	SSP1_DO (O)	N/A
GPIO_31	F22	B ₂	SSP1_DI (I)	N/A
GPIO_30	D25	B ₂	SSP1_CLK (B)	N/A
GPIO_29	E23	B ₂	IR1 (I)	SSP2 BC CSZ (B)
GPIO_28	C26	B ₂	IR0 (I)	SSP2 BC CSZ (B)
GPIO_27	AB4	B ₂	SSP0_CSZ3 (B)	N/A
GPIO_26	D24	B ₂	Blue LED enable (O)	UART2 TXD (O)
GPIO_25	C25	B ₂	Green LED enable (O)	LAMPSYNC (O)
GPIO_24	B26	B ₂	Red LED enable (O)	N/A
GPIO_23	E21	B ₂	LED Dual Current Control (O)	N/A
GPIO_22	D22	B ₂	LED Dual Current Control (O)	N/A
GPIO_21	E20	B ₂	LED Dual Current Control (O)	N/A
GPIO_20	C23	B ₂	N/A	N/A
GPIO_19	D21	B ₂	N/A	N/A
GPIO_18	B24	B ₂	N/A	N/A
GPIO_17	C22	B ₂	General Purpose Clock 2 (O)	N/A
GPIO_16	B23	B ₂	General Purpose Clock 1 (O)	N/A
GPIO_15	E19	B ₂	I2C_1 SDA (B)	N/A
GPIO_14	D20	B ₂	I2C_1 SCL (B)	N/A
GPIO_13	C21	B ₂	PWM IN_1 (I)	I2C_2 SDA (B)
GPIO_12	B22	B ₂	PWM IN_0 (I)	I2C_2 SCL (B)
GPIO_11	A23	B ₂	PWM STD_7 (O)	N/A
GPIO_10	A22	B ₂	PWM STD_6 (O)	N/A
GPIO_9	B21	B ₂	PWM STD_5 (O)	N/A
GPIO_8	A21	B ₂	PWM STD_4 (O)	N/A
GPIO_7	A20	B ₂	PWM STD_3 (O)	N/A
GPIO_6	C20	B ₂	PWM STD_2 (O)	N/A
GPIO_5	B20	B ₂	PWM STD_1 (O)	N/A
GPIO_4	B19	B ₂	PWM STD_0 (O)	N/A
GPIO_3	A19	B ₂	UART1_RTSSZ (O)	N/A
GPIO_2	E18	B ₂	UART1_CTSZ (I)	N/A
GPIO_1	D19	B ₂	UART1_RXD (I)	N/A
GPIO_0	C19	B ₂	UART1_TXD (O)	N/A
CLOCK and PLL SUPPORT				
MOSC	M26	I ₁₀	System clock oscillator input (3.3-V LVTTTL). Note that MOSC must be stable a maximum of 25 ms after POSENSE transitions from low to high.	
MOSCN	N26	O ₁₀	MOSC crystal return	
OCLKA	AF6	O ₅	General purpose output clock A. Targeted for driving the CW motor controller. The frequency is software programmable. Power-up default 787 KHz. Note that the output frequency is not affected by non-power-up reset operations (it will hold the last value programmed).	
DUAL CONTROLLER SUPPORT				
SEQ_SYNC	AB9	B ₃	Sequence sync. This signal is used in multi-controller configurations only, in which case the SEQSYNC signal from each controller is connected together with an external pullup. This signal is either pulled high or pulled low and not allowed to float for single controller configurations.	
POWER and GROUND				

Table 5-1. Pin Functions (continued)

PIN ⁽¹⁾		TYPE ⁽²⁾	DESCRIPTION
NAME	NO.		
VDD33	F20, F17, F11, F8, L21, R21, Y21, AA19, AA16, AA10, AA7	POWER	3.3-V I/O power
VDD18	C1, F5, G6, K6, M5, P5, T5, W6, AA5, AE1, H5, N6, T6, AA13, U21, P21, H21, F14	POWER	1.8-V internal DRAM and LVDS I/O power
VDD11	F19, F16, F13, F10, F7, H6, L6, P6, U6, Y6, AA8, AA11, AA14, AA17, AA20, W21, T21, N21, K21, G21, L11, T11, T16, L16	POWER	1.15-V core power
VDD_PLLD	L22	POWER	1.15-V DMD clock generator PLL digital power
VSS_PLLD	L23	GROUND	1.15-V DMD clock generator PLL digital ground
VAD_PLLD	K25	POWER	1.8-V DMD clock generator PLL analog power
VAS_PLLD	K26	GROUND	1.8-V DMD clock generator PLL analog ground
VDD_PLLM1	L26	POWER	1.15-V master-LS clock generator PLL digital power
VSS_PLLM1	M22	GROUND	1.15-V master-LS clock generator PLL digital ground
VAD_PLLM1	L24	POWER	1.8-V master-LS clock generator PLL analog power
VAS_PLLM1	L25	GROUND	1.8-V master-LS clock generator PLL analog ground
VDD_PLLM2	P23	POWER	master-HS clock generator PLL digital power
VSS_PLLM2	P24	GROUND	master-HS clock generator PLL digital ground
VAD_PLLM2	R25	POWER	1.8-V master-HS clock generator PLL analog power
VAS_PLLM2	R26	GROUND	1.8-V master-HS clock generator PLL analog ground
VAD_PLLS	R23	POWER	video-2X clock generator PLL analog power
VAS_PLLS	R24	GROUND	video-2X clock generator PLL analog ground
L-VDQPAD_[7:0], R-VDQPAD_[7:0]	B18, D18, B17, E17, A18, C18, A17, D17, AE17, AC17, AF17, AC18, AB16, AD17, AB17, AD18	RESERVED	These pins have to be tied directly to ground for normal operation.
CFO_VDD33	AE26	RESERVED	This pin has to be tied directly to 3.3 I/O power (VDD33) for normal operation.
VTEST1, VTEST2, VTEST3, VTEST4	AB14, AB15, E15, E16	RESERVED	These pins have to be tied directly to ground for normal operation.
LVDS_AVS1, LVDS_AVS2	V5, K5	POWER	These pins have to be tied directly to ground for normal operation.
VPGM	AC6	POWER	This pin has to be tied directly to ground for normal operation.

Table 5-1. Pin Functions (continued)

PIN ⁽¹⁾		TYPE ⁽²⁾	DESCRIPTION
NAME	NO.		
GROUND	A26, A25, A24, B25, C24, D23, E22, F21, F18, F15, F12, F9, F6, E5, D4, C3, B3, A3, B2, A2, B1, A1 G5, J5, J6, L5, M6, N5, R5, R6, U5, V6, W5, Y5, AA6, AB5, AC4, AD3, AE3, AF3, AF2, AF1, AA9, AA12, AA15, AA18, AA21, AB22, AC23, AD24, AE24, AF24, AE25, AF25, AF26, V21, M21, J21, L15, L14, L13, L12, M16, M15, M14, M13, M12, M11, N16, N15, N14, N13, N12, N11, P16, P15, P14, P13, P12, P11, R16, R15, R14, R13, R12, R11, T15, T14, T13, T12	GROUND	Common ground

- (1) For instructions on handling unused pins, see *General Handling Guidelines for Unused CMOS-Type Pins*.
- (2) I/O Type: I = Input, O = Output, B = Bidirectional, and H = Hysteresis. See [Table 5-2](#) for subscript explanation.
- (3) All JTAG signals are LVTTTL compatible.
- (4) Ports 1 and 2 can each be used to support multiple source options for a given product (for example AFE and HDMI). To do so, the data bus from both source components must be connected to the same port pins (1 or 2) and control given to the DLPC4430 device to tristate the "inactive" source. Tying them together like this causes some signal degradation due to reflections on the tristated path. Given the clock is the most critical signal, three Port clocks (1, 2, and 3) are provided to provide an option to improve the signal integrity.
- (5) Ports 1 and 2 can be used separately as two 30-bit ports, or can be combined into one 60-bit port (typically for high data rate sources) for transmission of two pixels per clock.
- (6) The A, B, C input data channels of Ports 1 and 2 can be internally reconfigured/ remapped for optimum board layout.
- (7) Sources feeding less than the full 10-bits per color component channel have to be MSB justified when connected to the DLPC4430 controller and the LSBs tied off to zero. For example an 8-bit per color input has to be connected to bits 9:2 of the corresponding A, B, C input channel.
- (8) GPIO signals must be configured by software for input, output, bidirectional, or open-drain. Some GPIOs have one or more alternate use modes, which are also software configurable. The reset default for all optional GPIOs is as an input signal. However, any alternate function connected to these GPIO pins with the exception of general-purpose clocks and PWM generation, are reset. An external pullup to the 3.3-V supply is required for each signal configured as open-drain. External pullup or pulldown resistors may be required to ensure stable operation before software is able to configure these ports.

Table 5-2. I/O Type Subscript Definition

SUBSCRIPT	DESCRIPTION	ESD STRUCTURE
2	3.3-V LVTTTL I/O buffer with 8-mA drive	ESD diode to VDD33 and GROUND
3	3.3-V LVTTTL I/O buffer with 12-mA drive	
4	3.3-V LVTTTL receiver	
5	3.3-V LVTTTL I/O buffer with 8-mA drive, with slew rate control	
6	3.3-V LVTTTL I/O buffer, with programmable 4-mA, 8-mA, or 12-mA drive	
7	1.8-V LVDS (DMD I/F)	
8	3.3-V I ² C with 3 mA sink	
9	USB Compatible (3.3 V)	
10	OSC 3.3-V I/O Compatible LVTTTL	

6 Specifications

6.1 Absolute Maximum Ratings

over operating free-air temperature range (unless otherwise noted)

		MIN	MAX	UNIT
ELECTRICAL				
Supply Voltage ⁽¹⁾	V _{DD11} (Core)	-0.30	1.60	V
	V _{DD18} (LVDS I/O and Internal DRAM)	-0.30	2.50	
	V _{DD33} (I/O)	-0.30	3.90	
	VDD_PLLD (DMD clock generator - Digital)	-0.30	1.60	
	VDD_PLLM1 (Master - LS clock generator - Digital)	-0.30	1.60	
	VDD_PLLM2 (Master - HS clock generator - Digital)	-0.30	1.60	
	VDD_PLLD (1.8-V DMD clock generator - Analog)	-0.30	2.50	
	VDD_PLLM1 (1.8-V Master - LS clock generator - Analog)	-0.30	2.50	
	VDD_PLLM2 (1.8-V Master - HS clock generator - Analog)	-0.30	2.50	
	VDD_PLLS (Video 2X - Analog)	-0.50	1.40	
V _I Input Voltage ⁽²⁾	USB	-1.0	5.25	V
	OSC	-0.3	V _{DD33} + 0.3	
	3.3-V LVTTTL	-0.3	3.6	
	3.3-V I2C	-0.5	3.8	
V _O Output Voltage	USB	-1.0	5.25	V
	OSC	-0.3	2.2	
	3.3-V LVTTTL	-0.3	3.6	
	3.3-V I2C	-0.5	3.8	
ENVIRONMENTAL				
T _J operating junction temperature		0	111	°C
T _{stg} storage temperature range		-40	125	°C

(1) All voltage values are with respect to GROUND.

(2) Applies to external input and bidirectional buffers

6.2 ESD Ratings

		VALUE	UNIT
V _(ESD) Electrostatic discharge	Human body model (HBM), per ANSI/ESDA/JEDEC JS-001, all pins ⁽¹⁾	± 1000	V
	Charged device model (CDM), per JEDEC specification JESD22-C101, all pins ⁽²⁾	+500/-300	

(1) Level listed above is the passing level per ANSI, ESDA, and JEDEC JS-001. JEDEC document JEP155 states that 500-V HBM allows safe manufacturing with a standard ESD control process.

(2) Level listed above is the passing level per EIA-JEDEC JESD22-C101. JEDEC document JEP157 states that 250-V CDM allows safe manufacturing with a standard ESD control process.

6.3 Recommended Operating Conditions

over operating free-air temperature range (unless otherwise noted)

		I/O ⁽¹⁾	MIN	NOM	MAX	UNIT
ELECTRICAL						

over operating free-air temperature range (unless otherwise noted)

		I/O ⁽¹⁾	MIN	NOM	MAX	UNIT
V _{DD33}	3.3-V supply voltage, I/O		3.135	3.3	3.465	V
V _{DD18}	1.8-V supply voltage, LVDS and DRAM		1.71	1.8	1.89	V
V _{DD11}	1.15-V supply voltage, core logic		1.100	1.15	1.200	V
VDD_PLLD	1.8-V supply voltage, PLL analog		1.71	1.8	1.89	V
VDD_PLLM1	1.8-V supply voltage, PLL analog		1.71	1.8	1.89	V
VDD_PLLM2	1.8-V supply voltage, PLL analog		1.71	1.8	1.89	V
VDD_PLLD	1.8-V supply voltage, PLL analog		1.090	1.15	1.200	V
VDD_PLLM1	1.8-V supply voltage, PLL analog		1.090	1.15	1.200	V
VDD_PLLM2	1.8-V supply voltage, PLL analog		1.090	1.15	1.200	V
VDD_PLLS	1.8-V supply voltage, PLL analog		1.090	1.15	1.200	V
V _I	Input voltage	USB (9)	0		V _{DD33}	V
		OSC (10)	0		V _{DD33}	
		3.3-V LVTTTL (1,2,3,4)	0		V _{DD33}	
		3.3-V I ² C (8)	0		V _{DD33}	
V _O	Output voltage	USB (8)	0		V _{DD33}	V
		3.3-V LVTTTL (1,2,3,4)	0		V _{DD33}	
		3.3-V I ² C (8)	0		V _{DD33}	
		1.8-V LVDS (7)	0		V _{DD33}	
T _A	Operating ambient temperature range	See ⁽²⁾ (3)	0		55	°C
T _C	Operating top center case temperature	See ⁽³⁾ (4)	0		109.16	°C
T _J	Operating junction temperature		0		111	°C

- (1) The number inside each parenthesis for the I/O refers to the type defined in the I/O type subscript definition section.
- (2) Assumes minimum 1 m/s airflow along with the JEDEC thermal resistance and associated conditions listed at www.ti.com/packaging. Thus, this is an approximate value that varies with environment and PCB design.
- (3) Maximum thermal values assume max power of 4.6 watts.
- (4) Assume Ψ_{sJT} equals 0.4 C/W

6.4 Thermal Information

THERMAL METRIC ⁽¹⁾		DLPC4430	UNIT
		ZPC (BGA)	
		516 PINS	
R _{θJA}	Junction-to-ambient thermal resistance ⁽²⁾	14.4	°C/W
R _{θJC}	Junction-to-case thermal resistance	4.4	°C/W

- (1) For more information about traditional and new thermal metrics, see the *Semiconductor and IC Package Thermal Metrics Application Report*.
- (2) In still air

6.5 Electrical Characteristics

over recommended operating conditions

PARAMETER		TEST CONDITIONS	MIN	TYP	MAX	UNIT
V _{IH}	High-level input voltage	USB (9)		2.0		V
		OSC (10)		2.0		
		3.3-V LVTTTL (1,2,3,4)		2.0		
		3.3-V I ² C (8)		2.4	VDD33V _{DD33} +0.5	

6.5 Electrical Characteristics (continued)

over recommended operating conditions

PARAMETER		TEST CONDITIONS	MIN	TYP	MAX	UNIT
V _{IL}	Low-level input voltage	USB (9)			0.8	V
		OSC (10)			0.8	
		3.3-V LVTTTL (1,2,3,4)			0.8	
		3.3-V I ² C (8)		-0.5	1.0	
V _{DIS}	Differential Input Voltage	USB(9)		200		mV
V _{ICM}	Differential cross point voltage	USB(9)		0.8	2.5	V
V _{HYS}	Hysteresis (V _{T+} – V _{T-})	USB(9)		200		mV
		3.3-V LVTTTL (1,2,3,4)		400		
		3.3-V I ² C (8)		300	550	
V _{OH}	High-level output voltage	USB (9)		2.8		V
		1.8-V LVDS (7)		1.520		
		3.3-V LVTTTL (1,2,3)	I _{OH} = Max Rated	2.7		
V _{OL}	Low-level output voltage	USB (9)		0.0	0.3	V
		1.8-V LVDS (7)			0.880	
		3.3-V LVTTTL (1,2,3)	I _{OL} = Max Rated		0.4	
		3.3-V I ² C (8)	I _{OL} = 3-mA sink		0.4	
V _{OD}	Output differential voltage	1.8-V LVDS (7)		0.065	0.440	V
I _{IH}	High-level input current	USB(9)			200	μA
		OSC (10)		-10.0	10	
		3.3-V LVTTTL (1-4) without internal pulldown	V _{IH} = VDD33	-10.0	10	
		3.3-V LVTTTL (1-4) with internal pulldown	V _{IH} = VDD33	10.0	200.0	
		3.3-V I ² C (8)	V _{IH} = VDD33		10.0	
I _{IL}	Low-level input current	USB(9)		-10.0	10.0	μA
		OSC (10)		-10.0	10.0	
		3.3-V LVTTTL (1-4) without internal pulldown	V _{OH} = VDD33	-10.0	10.0	
		3.3-V LVTTTL (1-4) with internal pulldown	V _{OH} = VDD33	-10.0	-200	
		3.3-V I ² C (8)	V _{OH} = VDD33		-10.0	
I _{OH}	High-level output current	USB(9)		-18.4		mA
		1.8-V LVDS (7) (V _{OD} = 300 mV)	VO = 1.4 V	6.5		
		3.3-V LVTTTL (1)	VO = 2.4 V	-4.0		
		3.3-V LVTTTL (2)	VO = 2.4 V	-8.0		
		3.3-V LVTTTL (3)	VO = 2.4 V	-12.0		

6.5 Electrical Characteristics (continued)

over recommended operating conditions

PARAMETER		TEST CONDITIONS	MIN	TYP	MAX	UNIT	
I _{OL}	Low-level output current	USB (9)			19.1	mA	
		1.8-V LVDS (7) (V _{OD} = 300 mV)	VO = 1.0 V		6.5		
		3.3-V LVTTTL (1)	VO = 0.4 V		4.0		
		3.3-V LVTTTL (2)	VO = 0.4 V		8.0		
		3.3-V LVTTTL (3)	VO = 0.4 V		12.0		
		3.3-V I ² C (8)			3.0		
I _{oz}	High-impedance leakage current	USB (9)			-10	pF	
		LVDS (7)			-10		
		3.3-V LVTTTL (1,2,3)			-10		
		3.3-V I ² C (8)			-10		
C _i	Input capacitance	USB (9)			11.84	pF	
		3.3-V LVTTTL (1)			3.75		5.52
		3.3-V LVTTTL (2)			3.75		5.52
		3.3-V LVTTTL (4)			3.75		5.52
		3.3-V I ² C (8)			5.26		6.54
I _{CC11}	Supply voltage, 1.15-V core power	Normal Mode			2368	mA	
I _{CC18}	Supply voltage, 1.8-V power (LVDS I/O and internal DRAM)	Normal Mode			1005	mA	
I _{CC33}	Supply voltage, 3.3-V I/O power	Normal Mode			33	mA	
I _{CC11_PLLD}	Supply voltage, DMD PLL Digital Power (1.15V)	Normal Mode		4.4	6.2	mA	
I _{CC11_PLLM1}	Supply voltage, Master-LS Clock Generator PLL Digital power (1.15V)	Normal Mode		4.4	6.2	mA	
I _{CC11_PLLM2}	Supply voltage, Master-HS Clock Generator PLL Digital power (1.15V)	Normal Mode		4.4	6.2	mA	
I _{CC18_PLLD}	Supply voltage, DMD PLL Analog Power (1.8 V)	Normal Mode		8.0	10.2	mA	
I _{CC18_PLLM1}	Supply voltage, Master-LS Clock Generator PLL Analog power (1.8 V)	Normal Mode		8.0	10.2	mA	
I _{CC18_PLLM2}	Supply voltage, Master-HS Clock Generator PLL Analog power (1.8 V)	Normal Mode		8.0	10.2	mA	
I _{CC11_PLLS}	Supply voltage, Video-2X PLL Analog Power (1.15 V)	Normal Mode			2.9	mA	
	Total Power	Normal Mode			4.76	W	
I _{CC11}	Supply voltage, 1.15V core power	Low Power Mode			21	mA	
I _{CC18}	Supply voltage, 1.8-V power (LVDS I/O and internal DRAM)	Low Power Mode			0	mA	
I _{CC33}	Supply voltage, 3.3-V I/O power	Low Power Mode			18	mA	
I _{CC11_PLLD}	Supply voltage, DMD PLL Digital Power (1.15V)	Low Power Mode			2.03	mA	
I _{CC11_PLLM1}	Supply voltage, Master-LS Clock Generator PLL Digital power (1.15V)	Low Power Mode			2.03	mA	
I _{CC11_PLLM2}	Supply voltage, Master-HS Clock Generator PLL Digital power (1.15V)	Low Power Mode			2.03	mA	
I _{CC18_PLLD}	Supply voltage, DMD PLL Analog Power (1.8 V)	Low Power Mode			5.42	mA	
I _{CC18_PLLM1}	Supply voltage, Master-LS Clock Generator PLL Analog power (1.8 V)	Low Power Mode			5.42	mA	

6.5 Electrical Characteristics (continued)

over recommended operating conditions

PARAMETER		TEST CONDITIONS	MIN	TYP	MAX	UNIT
I_{CC18_PLL2}	Supply voltage, Master-HS Clock Generator PLL Analog power (1.8 V)	Low Power Mode			5.42	mA
I_{CC11_PLLS}	Supply voltage, Video-2X PLL Analog Power (1.15V)	Low Power Mode			.03	mA
Total Power		Low Power Mode			106	mW

6.6 System Oscillators Timing Requirements

over operating free-air temperature range(unless otherwise noted)

PARAMETER		TEST CONDITIONS	MIN	MAX	UNIT
SYSTEM OSCILLATORS					
f_{clock}	Clock frequency, MOSC ⁽¹⁾		19.998	20.002	MHz
t_c	Cycle time, MOSC ⁽¹⁾		49.995	50.005	MHz
$t_{w(H)}$	Pulse duration ⁽²⁾ , MOSC, high	50% to 50% reference points (signal)	20		ns
$t_{w(L)}$	Pulse duration ⁽²⁾ , MOSC, low	50% to 50% reference points (signal)	20		ns
t_t	Transition time ⁽²⁾ , MOSC, $t_t = t_f / t_r$	20% to 80% reference points (signal)		12	ns
t_{jp}	Period Jitter ⁽²⁾ , MOSC (This is the deviation in period from the ideal period due solely to high frequency jitter).			18	ps

- (1) The frequency range for MOSC is 20 MHz with +/-100 PPM accuracy (it includes impact to accuracy due to aging, temperature and trim sensitivity). The MOSC input cannot support spread spectrum clock spreading.
(2) Applies only when driven via an external digital oscillator.

6.7 Test and Reset Timing Requirements

			MIN	MAX	UNIT
$t_{W1(L)}$	Pulse duration, inactive low, PWRGOOD	50% to 50% reference points (signal)	4.0		μ s
$t_{W1(L)}$	Pulse duration, inactive low, PWRGOOD	50% to 50% reference points (signal)		1000 ⁽²⁾	ms
t_{t1}	Transition time, PWRGOOD, $t_{t1} = t_f / t_r$	20% to 80% reference points (signal)		625	μ s
$t_{W2(L)}$	Pulse duration, inactive low, POSENSE	50% to 50% reference points (signal)	500		μ s
$t_{W2(L)}$	Pulse duration, inactive low, POSENSE	50% to 50% reference points (signal)		1000 ⁽²⁾	ms
t_{t2}	Transition time, POSENSE, $t_{t1} = t_f / t_r$	20% to 80% reference points (signal)		25 ⁽¹⁾	μ s
t_{PH}	Power Hold time, POSENSE remains active after PWRGOOD is de-asserted	20% to 80% reference points (signal)	500		μ s
t_{EW}	Early Warning time, PWRGOOD goes inactive low prior to any power supply voltage going below its specification		500		μ s
$t_{W1(L)} + t_{W2(L)}$	The sum of PWRGOOD and POSENSE inactive time			1050 ⁽²⁾	ms

- (1) As long as noise on this signal is below the hysteresis threshold.
(2) With 1.8 V power applied. If the 1.8 V power is disabled by the controller command (For example – if system is placed in Low Power mode where the controller disables 1.8 V power), these signals can be placed and remain in their inactive state indefinitely.

6.8 JTAG Interface: I/O Boundary Scan Application Timing Requirements

			MIN	MAX	UNIT
f_{clock}	Clock frequency, TCK			10	MHZ
t_{C}	Cycle time, TCK		100		ns
$t_{\text{W(H)}}$	Pulse duration, high	50% to 50% reference points (signal)	40		ns
$t_{\text{W(L)}}$	Pulse duration, low	50% to 50% reference points (signal)	40		ns
t_{t}	Transition time, $t_{\text{t}} = t_{\text{f}}/t_{\text{r}}$	20% to 80% reference points (signal)		5	ns
t_{SU}	Setup time, TDI valid before TCK \uparrow		8		ns
t_{h}	Hold time, TDI valid after TCK \uparrow		2		ns
t_{SU}	Setup time, TMS1 valid before TCK \uparrow		8		ns
t_{h}	Hold time, TMS1 valid before TCK \uparrow		2		ns

6.9 Port 1 Input Pixel Timing Requirements

		TEST CONDITIONS	MIN	MAX	UNIT
f_{clock}	Clock frequency, P_CLK1, P_CLK2, P_CLK3 (30-bit bus)		12	175	MHZ
f_{clock}	Clock frequency, P_CLK1, P_CLK2, P_CLK3 (60-bit bus)		12	141	MHZ
t_{C}	Cycle Time, P_CLK1, P_CLK2, P_CLK3		5.714	83.33	ns
$t_{\text{W(H)}}$	Pulse Duration, high	50% to 50% reference points (signal)	2.3		ns
$t_{\text{W(L)}}$	Pulse Duration, low	50% to 50% reference points (signal)	2.3		ns
t_{jp}	Clock period jitter, P_CLK1, P_CLK2, P_CLK3	Max f_{clock}		See (2)	ps
t_{t}	Transition time, $t_{\text{t}} = t_{\text{f}}/t_{\text{r}}$, P_CLK1, P_CLK2, P_CLK3	20% to 80% reference points (signal)	0.6	2.0	ns
t_{t}	Transition time, $t_{\text{t}} = t_{\text{f}}/t_{\text{r}}$, P1_A(9-0), P1_B(9-0), P1_C(9-0), P1_HSYNC, P1_VSYNC, P1_DATAEN	20% to 80% reference points (signal)	0.6	3.0	ns
t_{t}	Transition time, $t_{\text{t}} = t_{\text{f}}/t_{\text{r}}$, ALF_HSYNC, ALF_VSYNC, ALF_CS $\overline{\text{SYNC}}$ (1)	20% to 80% reference points (signal)	0.6	3.0	ns
SETUP AND HOLD TIMES					
t_{su}	Setup time, P1_A(9-0), valid before P_CLK1 $\uparrow\downarrow$, P_CLK2 $\uparrow\downarrow$, or P_CLK3 $\uparrow\downarrow$		0.8		ns
t_{h}	Hold time, P1_A(9-0), valid before P_CLK1 $\uparrow\downarrow$, P_CLK2 $\uparrow\downarrow$, or P_CLK3 $\uparrow\downarrow$		0.8		ns
t_{su}	Setup time, P1_B(9-0), valid before P_CLK1 $\uparrow\downarrow$, P_CLK2 $\uparrow\downarrow$, or P_CLK3 $\uparrow\downarrow$		0.8		ns
t_{h}	Hold time, P1_B(9-0), valid before P_CLK1 $\uparrow\downarrow$, P_CLK2 $\uparrow\downarrow$, or P_CLK3 $\uparrow\downarrow$		0.8		ns
t_{su}	Setup time, P1_C(9-0), valid before P_CLK1 $\uparrow\downarrow$, P_CLK2 $\uparrow\downarrow$, or P_CLK3 $\uparrow\downarrow$		0.8		ns
t_{h}	Hold time, P1_C(9-0), valid before P_CLK1 $\uparrow\downarrow$, P_CLK2 $\uparrow\downarrow$, or P_CLK3 $\uparrow\downarrow$		0.8		ns
t_{su}	Setup time, P1_VSYNC, valid before P_CLK1 $\uparrow\downarrow$, P_CLK2 $\uparrow\downarrow$, or P_CLK3 $\uparrow\downarrow$		0.8		ns
t_{h}	Hold time, P1_VSYNC valid before P_CLK1 $\uparrow\downarrow$, P_CLK2 $\uparrow\downarrow$, or P_CLK3 $\uparrow\downarrow$		0.8		ns
t_{su}	Setup time, P1_HSYNC, valid before P_CLK1 $\uparrow\downarrow$, P_CLK2 $\uparrow\downarrow$, or P_CLK3 $\uparrow\downarrow$		0.8		ns
t_{h}	Hold time, P1_HSYNC valid before P_CLK1 $\uparrow\downarrow$, P_CLK2 $\uparrow\downarrow$, or P_CLK3 $\uparrow\downarrow$		0.8		ns

6.9 Port 1 Input Pixel Timing Requirements (continued)

		TEST CONDITIONS	MIN	MAX	UNIT
t _{su}	Setup time, P2_A(9-0), valid before P_CLK1↑↓, P_CLK2↑↓, or P_CLK3↑↓		0.8		ns
t _h	Hold time, P2_A(9-0), valid before P_CLK1↑↓, P_CLK2↑↓, or P_CLK3↑↓		0.8		ns
t _{su}	Setup time, P2_B(9-0), valid before P_CLK1↑↓, P_CLK2↑↓, or P_CLK3↑↓		0.8		ns
t _h	Hold time, P2_B(9-0), valid before P_CLK1↑↓, P_CLK2↑↓, or P_CLK3↑↓		0.8		ns
t _{su}	Setup time, P2_C(9-0), valid before P_CLK1↑↓, P_CLK2↑↓, or P_CLK3↑↓		0.8		ns
t _h	Hold time, P2_C(9-0), valid before P_CLK1↑↓, P_CLK2↑↓, or P_CLK3↑↓		0.8		ns
t _{su}	Setup time, P2_VSYNC, valid before P_CLK1↑↓, P_CLK2↑↓, or P_CLK3↑↓		0.8		ns
t _h	Hold time, P2_VSYNC valid before P_CLK1↑↓, P_CLK2↑↓, or P_CLK3↑↓		0.8		ns
t _{su}	Setup time, P2_HSYNC, valid before P_CLK1↑↓, P_CLK2↑↓, or P_CLK3↑↓		0.8		ns
t _h	Hold time, P2_HSYNC valid before P_CLK1↑↓, P_CLK2↑↓, or P_CLK3↑↓		0.8		ns
t _{su}	Setup time, P_DATAEN1, valid before P_CLK1↑↓, P_CLK2↑↓, or P_CLK3↑↓		0.8		ns
t _h	Hold time, P_DATAEN1 valid before P_CLK1↑↓, P_CLK2↑↓, or P_CLK3↑↓		0.8		ns
t _{su}	Setup time, P_DATAEN2, valid before P_CLK1↑↓, P_CLK2↑↓, or P_CLK3↑↓		0.8		ns
t _h	Hold time, P_DATAEN2 valid before P_CLK1↑↓, P_CLK2↑↓, or P_CLK3↑↓		0.8		ns
t _{w(A)}	VSYNC Active Pulse Width		1		Video Line
t _{w(A)}	HSYNC Active Pulse Width		16		Pixel Clocks

- (1) ALF_CSYNC, ALF_VSYNC and ALF_HSYNC are Asynchronous signals.
(2) For frequencies (f_{clock}) less than 175 MHz, use following formula to obtain the jitter: Max Clock Jitter = +/- [(1/f_{clock}) – 5414 ps]

6.10 Port 3 Input Pixel Interface (via GPIO) Timing Requirements

PARAMETER		TEST CONDITIONS	MIN	MAX	UNIT
f _{clock}	Clock Frequency, P3_CLK		27	54	MHz
t _c	Cycle time, P3_CLK		18.5	37.1	ns
t _{w(H)}	Pulse Duration, high	50% to 50% reference points (signal)	7.4		ns
t _{w(L)}	Pulse Duration, low	50% to 50% reference points (signal)	7.4		ns
t _{jp}	Clock period jitter, P3_CLK	Max f _{clock}	See (1)	See (1)	ps
t _t	Transition time, t _t = t _f /t _r , P3_CLK	20% to 80% reference points (signal)	1.0	5.0	ns
t _t	Transition time, t _t = t _f /t _r , P3_DATA(9-0)	20% to 80% reference points (signal)	1.0	5.0	ns
t _{su}	Setup time, P3_DATA(9-0) valid before P3_CLK↑↓		2.0		ns
t _h	Hold time, P3_DATA(9-0) valid after P3_CLK↑↓		2.0		ns

- (1) For frequencies less than 54 MHz, use following formula to obtain the jitter: Jitter = [(1/F) – 5414 ps].

6.11 DMD LVDS Interface Timing Requirements

		FROM (INPUT)	TO (OUTPUT)	MIN	MAX	UNIT
f_{clock}	Clock frequency, DCK_A	N/A	DCK_A	100	400	MHz
t_{C}	Cycle time, DCK_A ⁽¹⁾	N/A	DCK_A	2475.3		ps
$t_{\text{W(H)}}$	Pulse duration, high	N/A	DCK_A	1093		ps
$t_{\text{W(L)}}$	Pulse duration, low	N/A	DCK_A	1093		ps
t_{t}	Transition time, $t_{\text{t}} = t_{\text{f}}/t_{\text{r}}$	N/A	DCK_A	100	400	ps
t_{osu}	Output Setup time at max clock rate ⁽²⁾	DCK_A $\uparrow\downarrow$	SCA, DDA(15:0)	438		ps
t_{oh}	Output hold time at max clock rate ⁽²⁾	DCK_A $\uparrow\downarrow$	SCA, DDA(15:0)	438		ps
f_{clock}	Clock frequency, DCK_B	N/A	DCK_B	100	400	MHz
t_{C}	Cycle time, DCK_B ⁽¹⁾	N/A	DCK_B	2475.3		ps
$t_{\text{W(H)}}$	Pulse duration, high	N/A	DCK_B	1093		ps
$t_{\text{W(L)}}$	Pulse duration, low	N/A	DCK_B	1093		ps
t_{t}	Transition time, $t_{\text{t}} = t_{\text{f}}/t_{\text{r}}$	N/A	DCK_B	100	400	ps
t_{osu}	Output Setup time at max clock rate ⁽²⁾	DCK_B $\uparrow\downarrow$	SCA, DDB(15:0)	438		ps
t_{oh}	Output hold time at max clock rate ⁽²⁾	DCK_B $\uparrow\downarrow$	SCA, DDB(15:0)	438		ps
t_{sk}	Output Skew, Channel A to Channel B	DCK_A \uparrow	DCK_B \uparrow		250	ps

- (1) The minimum cycle time (t_{C}) for DCK_A and DCL_B includes 1.0% spread spectrum modulation. User must verify that DMD can support this rate.
- (2) Output Setup and Hold times for DMD clock frequencies below the maximum can be calculated as follows: $t_{\text{osu}}(f_{\text{clock}}) = t_{\text{osu}}(f_{\text{max}}) + 250000 \times (1/f_{\text{clock}} - 1/400)$ and $t_{\text{oh}}(f_{\text{clock}}) = t_{\text{oh}}(f_{\text{max}}) + 250000 \times (1/f_{\text{clock}} - 1/400)$ where f_{clock} is in MHz.

6.12 Synchronous Serial Port (SSP) Interface Timing Requirements

PARAMETER		TEST CONDITIONS	MIN	MAX	UNIT
SSP Primary					
t_{su}	Setup time, SSPx_DI valid before SSPx_CLK		15		ns
t_{su}	Setup time, SSPx_DI valid before SSPx_CLK		15		ns
t_{h}	Hold time, SSPx_DI valid after SSPx_CLK		0		ns
t_{h}	Hold time, SSPx_DI valid after SSPx_CLK		0		ns
t_{t}	Transition time, SSPx_DI, $t_{\text{t}} = t_{\text{f}}/t_{\text{r}}$	20% to 80% reference points (signal)		1.5	ns
SSP Secondary					
t_{su}	Setup time, SSPx_DI valid before SSPx_CLK		12		ns
t_{su}	Setup time, SSPx_DI valid before SSPx_CLK		12		ns
t_{h}	Hold time, SSPx_DI valid after SSPx_CLK		12		ns
t_{h}	Hold time, SSPx_DI valid after SSPx_CLK		12		ns
t_{t}	Transition time, SSPx_DI, $t_{\text{t}} = t_{\text{f}}/t_{\text{r}}$	20% to 80% reference points (signal)		1.5	ns

6.13 Programmable Output Clocks Switching Characteristics

over operating free air temperature range, $C_L(\text{min timing}) = 5 \text{ pF}$, $C_L(\text{max timing}) = 50 \text{ pF}$ (unless otherwise noted)

PARAMETER		TEST CONDITIONS	TO (OUTPUT)	MIN	MAX	UNIT
f_{clock}	Clock frequency, OCLKA ⁽¹⁾		OCLKA	0.787	50	MHz
t_c	Cycle Time, OCLKA		OCLKA	20	1270.6	ns
$t_{W(H)}$	Pulse Duration, high ⁽²⁾	50% to 50% reference points (signal)	OCLKA	$(t_c/2_{-2})$		ns
$t_{W(L)}$	Pulse Duration, low ⁽²⁾	50% to 50% reference points (signal)	OCLKA	$(t_c/2_{-2})$		ns
	Jitter		OCLKA		350	ps
f_{clock}	Clock frequency, OCLKB ⁽¹⁾		OCLKB	0.787	50	MHz
t_c	Cycle Time, OCLKB		OCLKB	20	1270.6	ns
$t_{W(H)}$	Pulse Duration, high ⁽²⁾	50% to 50% reference points (signal)	OCLKB	$(t_c/2_{-2})$		ns
$t_{W(L)}$	Pulse Duration, low ⁽²⁾	50% to 50% reference points (signal)	OCLKB	$(t_c/2_{-2})$		ns
	Jitter		OCLKB		350	ps
f_{clock}	Clock frequency, OCLKC ⁽¹⁾		OCLKC	0.787	50	MHz
t_c	Cycle Time, OCLKC ⁽²⁾		OCLKC	20	1270.6	ns
$t_{W(H)}$	Pulse Duration, high	50% to 50% reference points (signal)	OCLKC	$(t_c/2_{-2})$		ns
$t_{W(L)}$	Pulse Duration, low ⁽²⁾	50% to 50% reference points (signal)	OCLKC	$(t_c/2_{-2})$		ns
	Jitter		OCLKC		350	ps

(1) The frequency of OCLKA thru OCLKC is programmable.

(2) The Duty Cycle of OCLKA thru OCLKC is within +/- 2 ns of 50%.

6.14 Synchronous Serial Port Interface (SSP) Switching Characteristics

over operating free-air temperature range, $C_L(\text{min timing}) = 5 \text{ pF}$, $C_L(\text{max timing}) = 50 \text{ pF}$ (unless otherwise noted)

PARAMETER		TEST CONDITIONS	FROM (INPUT)	TO (OUTPUT)	MIN	MAX	UNIT
f_{clock}	Clock Frequency, SSPx_CLK		N/A	SSPx_CLK	73	25000	kHz
t_c	Cycle time, SSPx_CLK		N/A	SSPx_CLK	0.040	13.6	μs
$t_{W(H)}$	Pulse Duration, high	50% to 50% reference points (signal)	N/A	SSPx_CLK	40%		
$t_{W(L)}$	Pulse Duration, low	50% to 50% reference points (signal)	N/A	SSPx_CLK	40%		
SSP Primary ⁽¹⁾							
t_{pd}	Output Propagation, Clock to Q, SSPx_DO ⁽²⁾		SSPx_CLK↓	SSPx_DO	-5	5	ns
t_{pd}	Output Propagation, Clock to Q, SSPx_DO ⁽²⁾		SSPx_CLK↑	SSPx_DO	-5	5	ns
SSP Secondary ⁽¹⁾							
t_{pd}	Output Propagation, Clock to Q, SSPx_DO ⁽²⁾		SSPx_CLK↓	SSPx_DO	0	34	ns
t_{pd}	Output Propagation, Clock to Q, SSPx_DO ⁽²⁾		SSPx_CLK↑	SSPx_DO	0	34	ns

(1) The SSP can be used as an SSP Primary, or as an SSP Secondary. When used as a Primary, the SSP can be configured to sample DI with the same internal clock edge used to transmit the next DO, which provides a full cycle rather than a half cycle timing path, allowing operation at higher SPI clock frequencies.

(2) The SSP can be configured into four different operational modes/configurations.

Table 6-1. SSP Clock Operational Modes

SPI Clocking Mode	SPI Clock Polarity (CPOL)	SPI Clock Phase (CPHA)
0	0	0
1	0	1
2	1	0
3	1	1

6.15 JTAG Interface: I/O Boundary Scan Application Switching Characteristics

over operating free-air temperature range, $C_L(\text{min timing}) = 5 \text{ pF}$, $C_L(\text{max timing}) = 85 \text{ pF}$ (unless otherwise noted)

PARAMETER	FROM INPUT	TO OUTPUT	MIN	MAX	UNIT	
t_{pd}	Output Propagation, Clock to Q	TCK↓	TDO1	3	12	ns

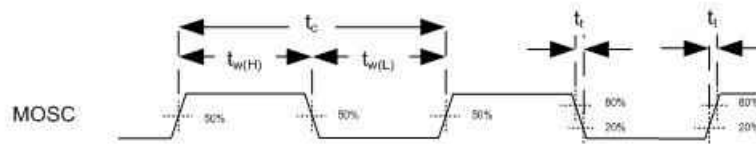

Figure 6-1. System Oscillators

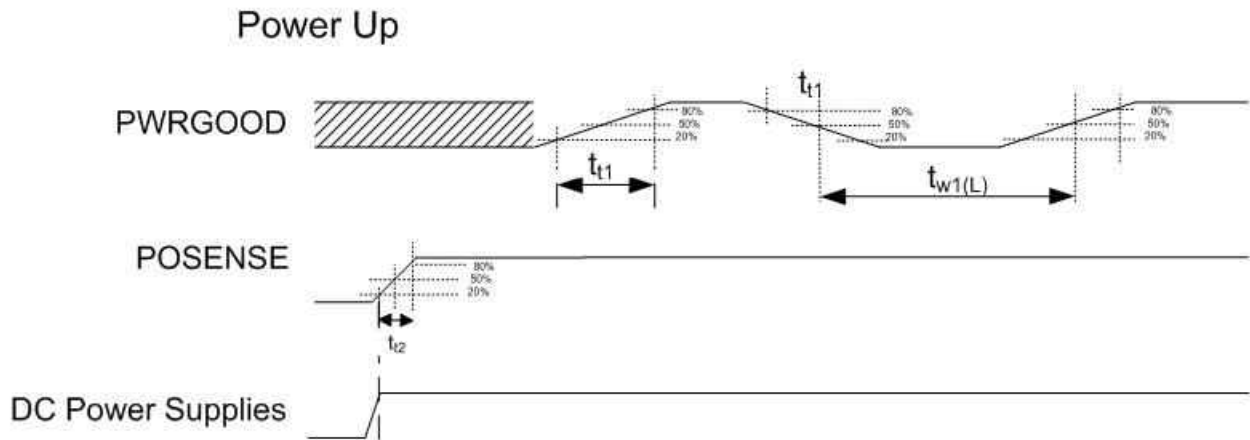

Figure 6-2. Power Up

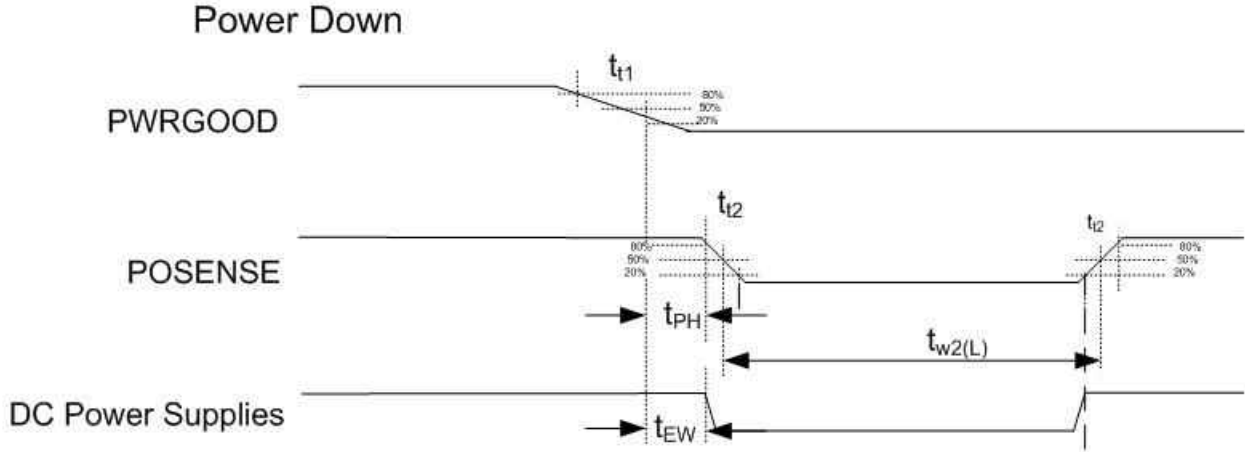

Figure 6-3. Power Down

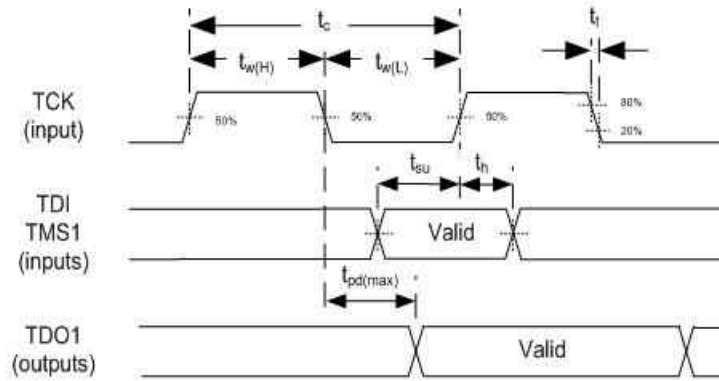

Figure 6-4. I/O Boundary Scan

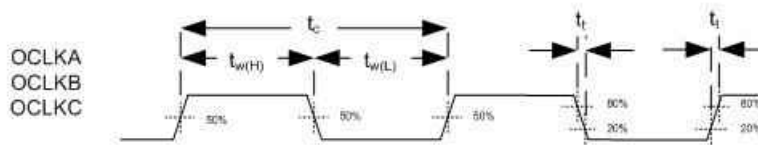

Figure 6-5. Programmable Output Clocks

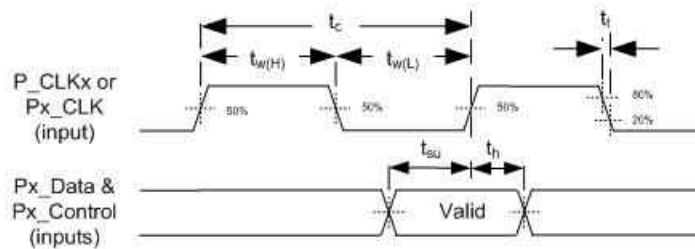

Figure 6-6. Port1, Port2, and Port3 Input Interface

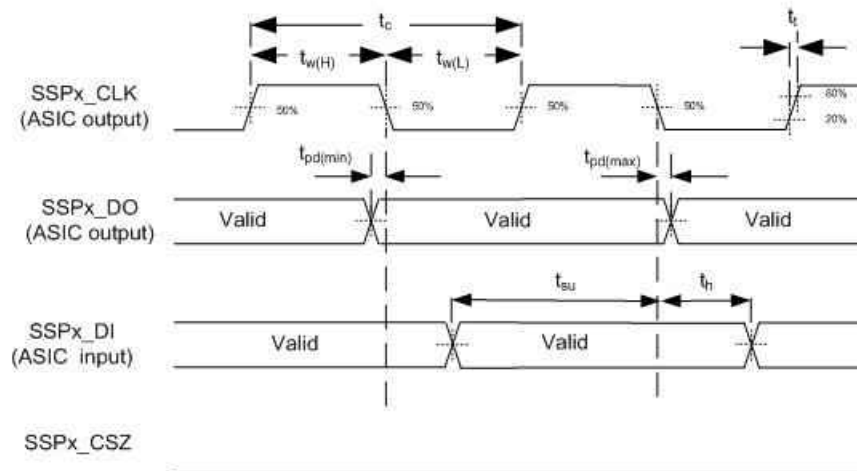

Figure 6-7. Synchronous Serial Port Interface—Primary

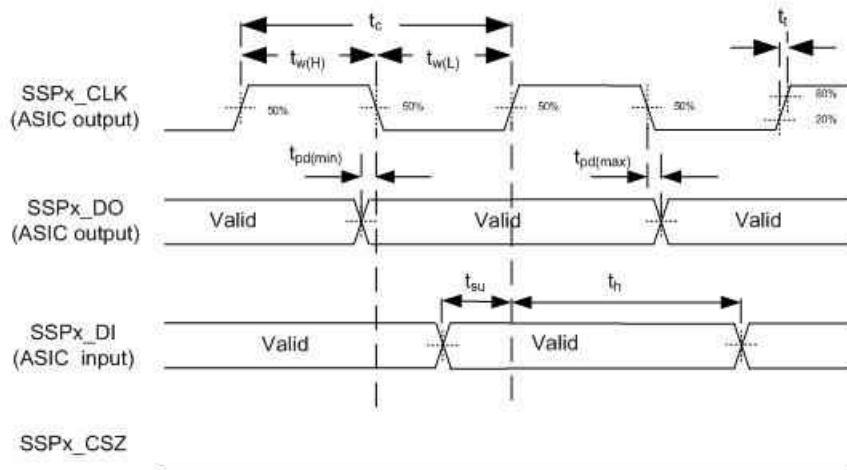

Figure 6-8. Synchronous Serial Port Interface—Secondary

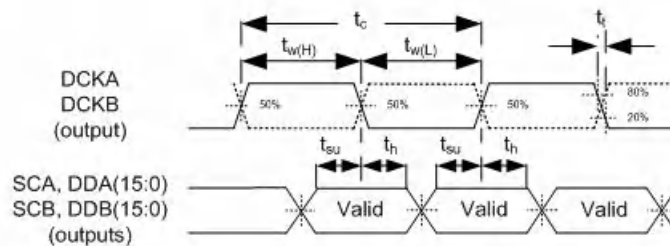

Figure 6-9. DMD LVDS Interface

7 Detailed Description

7.1 Overview

As with prior DLP electronics solutions, image data is 100% digital from the DLPC4430 input port to the image projected on to the display screen. The image stays in digital form and is never converted into an analog signal. The DLPC4430 processes the digital input image and converts the data into bit-plane format as needed by the DMD. The DLPC4430 display controller is optimized for high-resolution and high-brightness display applications. Applications include home theatre, smart display, digital signage, and laser TV.

7.2 Functional Block Diagram

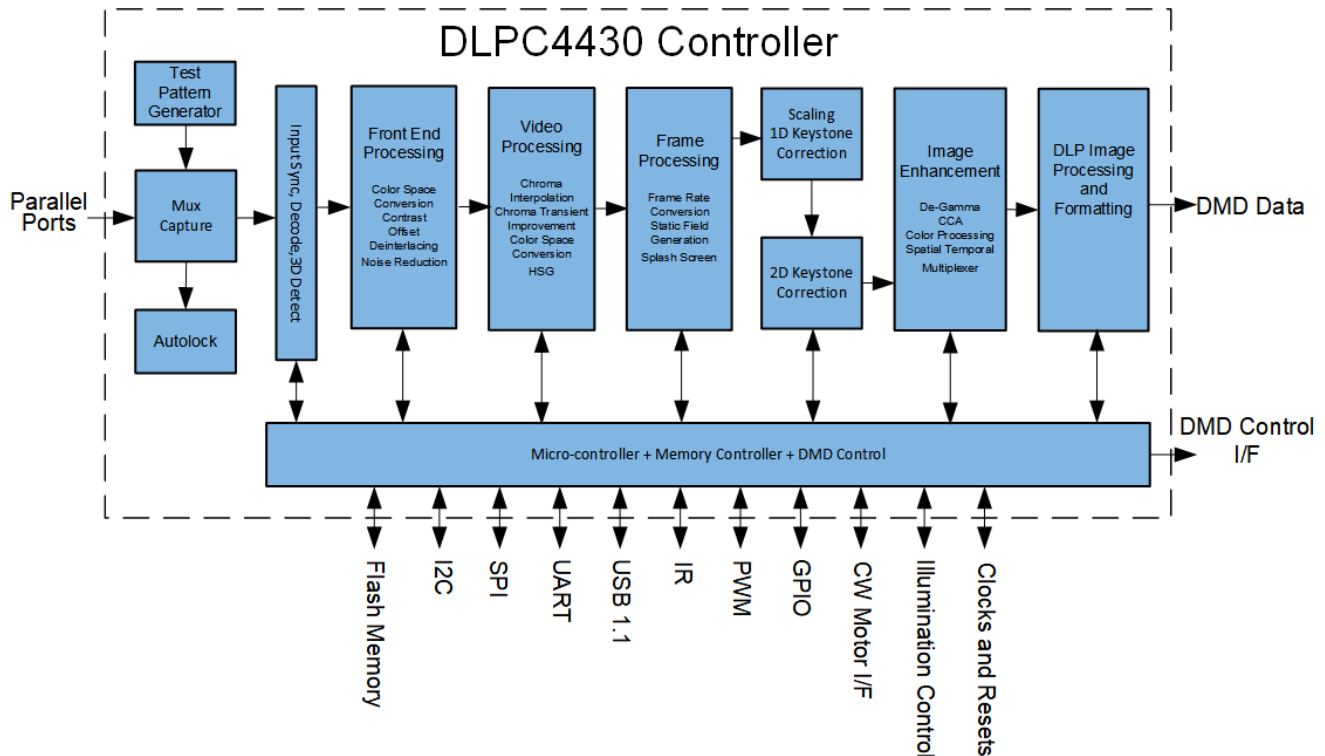

7.3 Feature Description

7.3.1 System Reset Operation

7.3.1.1 Power-Up Reset Operation

Immediately following a power-up event, the DLPC4430 hardware automatically brings up the primary PLL and places the controller in normal power mode. Then, the hardware follows the standard system reset procedure (see [Section 7.3.1.2](#)).

7.3.1.2 System Reset Operation

Immediately following any type of system reset (power-up reset, PWRGOOD reset, watchdog timer timeout, lamp-strike reset), the DLPC4430 device automatically returns to NORMAL power mode in the following state:

- All GPIO are tristated.
- The primary PLL remains active (it is reset only after a power-up reset sequence) and most of the derived clocks are active. However, only those resets associated with the ARM9 processor and its peripherals are released (the ARM9 is responsible for releasing all other resets).
- ARM9 associated clocks default to their full clock rates. (Boot-up is a full speed.)
- All front-end clocks derived are disabled.
- The PLL feeding the LVDS DMD I/F (PLL_D) defaults to its power-down mode and all derived clocks are inactive with corresponding resets asserted. (The ARM9 is responsible for enabling these clocks and releasing associated resets.)

- LVDS I/O defaults to its power-down mode with outputs tristated.
- All resets output by the DLPC4430 device remain asserted until released by the ARM9 (after boot-up).
- The ARM9 processor boots-up from external flash.

When the ARM9 boots-up, the ARM9 API:

- Configures the programmable DDR Clock Generator (DCG) clock rates (that is, the DMD LVDS I/F rate)
- Enables the DCG PLL (PLL) while holding divider logic in reset
- When the DCG PLL locks, ARM9 software sets DMD clock rates
- API software then releases DCG divider logic resets, which in turn, enable all derived DCG clocks
- Release external resets

Application software then typically waits for a wake-up command (through the soft power switch on the projector) from the end user. When the projector is requested to wake-up, the software places the ASIC back in normal mode, re-initialize clocks, and resets as required.

7.3.2 Spread Spectrum Clock Generator Support

The DLPC4430 controller supports limited, internally-controlled, spread spectrum clock spreading on the DMD interface. The purpose of this is to frequency spread all signals on this high-speed, external interface to reduce EMI emissions. Clock spreading is limited to triangular waveforms. The DLPC4430 controller provides modulation options of 0%, +/-0.5% and +/-1.0% (center-spread modulation).

7.3.3 GPIO Interface

The DLPC4430 controller provides 83 software-programmable, general-purpose I/O pins. Each GPIO pin is individually configurable as either input or output. In addition, each GPIO output can be either configured as push-pull or open-drain. Some GPIO have one or more alternate-use modes, which are also software configurable. The reset default for all GPIO is as an input signal. However, any alternate function connected to these GPIO pins, with the exception of general purpose clocks and PWM generation, stay in reset. When configured as open-drain, the outputs must be externally pulled-up (to the 3.3-V supply). External pull-up or pulldown resistors may be required to ensure stable operation before software is able to configure these ports.

7.3.4 Source Input Blanking

Vertical and horizontal blanking requirements for both input ports are defined as follows (See *Video Timing Parameter Definitions*).

- Minimum port 1 and port 2 vertical blanking
 - Vertical back porch (VBP): 370 μ s
 - Vertical front porch (VFP): 1 line
 - Total vertical blanking (TVB): 370 μ s + 2 lines
- Minimum port1 and port 2 horizontal blanking
 - Horizontal back porch (HBP): 10 pixels
 - Horizontal front porch (HFP): 0 pixels
 - Total horizontal blanking (THB): 80 pixels

7.3.5 Video Graphics Processing Delay

The DLPC4430 controller introduces a variable number of field/ frame delays dependent on the source type and selected processing steps performed on the source. For optimum audio/ video synchronization this delay must be matched in the audio path. The following tables define various video delay scenarios to aid in audio matching.

Frame and Fields in table refer to source frames and fields.

- For 2-D sources, “N” is defined to be the ratio of the primary channel source frame rate (or field rate for interlaced video) to the display frame/ field rate.
- For 3-D sources, “M” is defined to be the ratio of the primary channel source frame rate (or field rate for interlaced video) required to obtain both the left and right image, to the display frame/field rate (The rate at which each eye is displayed).

Table 7-1. Primary Channel/Video-Graphics Processing Delay

Source	Frame Rate Conversion	FRC Type	Formatter Buffer	Total Delay
48 Hz Graphics	1 Frame	Sync (1:1)	N Frames	1 + N Frames
50 Hz Graphics	1 Frame	Sync (1:1)	N Frames	1 + N Frames
60 Hz Graphics	1 Frame	Sync (1:1)	N Frames	1 + N Frames
100 and 120 Hz Graphics	1 Frame	Sync (1:1)	N Frames	1 + N Frames
100 and 120 Hz Graphics (3D)	1 Frame	Sync (1:2)	M Frames	1 + M Frames

7.3.6 Program Memory Flash/SRAM Interface

The DLPC4430 controller provides three external program memory chip selects:

- PM_CSZ_0 – available for optional SRAM or flash device (≤ 128 Mb)
- PM_CSZ_1 – dedicated CS for boot flash device (ie. Standard NOR-type flash, ≤ 128 Mb)
- PM_CSZ_2 – available for optional SRAM or flash device (≤ 128 Mb)

Flash and SRAM access timing is software programmable up to 31 wait states. Wait state resolution is 6.7 ns in normal mode and 53.33 ns in low power modes. Wait state program values for typical flash access times are shown in the [Table 7-2](#).

Table 7-2. Wait State Program Values for Typical Flash Access Times

	Normal Mode ⁽¹⁾	Low Power Mode ⁽¹⁾
Formula to Calculate the Required Wait State Value	= Roundup (Device_Access_Time / 6.7 ns)	= Roundup (Device_Access_Time / 53.33 ns)
Max Supported Device Access Time	207 ns	1660 ns

(1) Assumes a maximum single direction trace length of 75 mm.

Note that when another device such as an SRAM or additional flash is used in conjunction with the boot flash, care must be taken to keep stub length short and located as close as possible to the flash end of the route.

The DLPC4430 controller provides enough Program Memory Address pins to support a flash or SRAM device up to 128 Mb. For systems not requiring this capacity, up to two address pins can be used as GPIO instead. Specifically, the two most significant address bits (i.e. PM_ADDR_22 and PM_ADDR_21) are shared on pins GPIO_36 and GPIO_35 respectively. Like other GPIO pins, these pins float in a high-impedance input state following reset; therefore, if these GPIO pins are to be reconfigured as Program Memory Address pins, they require board-level pull-down resistors to prevent any flash address bits from floating until software is able to reconfigure the pins from GPIO to Program Memory Address. Also note that until software reconfigures the pins from GPIO to Program Memory Address, upper portions of flash memory are not accessible.

[Table 7-3](#) shows typical GPIO_35 and GPIO36 pin configuration for various flash sizes.

Table 7-3. Typical GPIO_35 and GPIO_36 Pin Configurations for Various Flash Sizes

FLASH SIZE	GPIO_36 Pin Configuration	GPIO_35 Pin Configuration
32 Mb or less	GPIO_36	GPIO_35
64 Mb	GPIO_36	PM_ADDR_21 ⁽¹⁾
128 Mb	PM_ADDR_22 ⁽¹⁾	PM_ADDR_21 ⁽¹⁾

(1) Board-level pulldown resistor required.

7.3.7 Calibration and Debug Support

The DLPC4430 controller contains a test point output port, TSTPT_(7:0), which provides selected system calibration support as well as ASIC debug support. These test points are inputs while reset is applied and switch to outputs when reset is released. The state of these signals is sampled upon the release of system reset and the captured value configures the test mode until the next time reset is applied. Each test point includes an internal pull-down resistor and thus external pull-ups are used to modify the default test configuration. The default configuration (x00) corresponds to the TSTPT_(7:0) outputs being driven low for reduce switching activity

during normal operation. For maximum flexibility, an option to jumper to an external pull-up is recommended for TSTPT_(3:0). Note that adding pull-up to TSTPT_(7:4) may have adverse affects for normal operation and are not recommended. Note that these external pull-ups are only sampled upon a zero to one transition on POSENSE and thus changing their configuration after reset has been released does not have any effect until the next time reset is asserted and released. [Table 7-4](#) defines the test mode selection for 3 of the 16 programmable scenarios defined by TSTPT_(3:0):

Table 7-4. Test Mode Selection

	No Switching Activity	System Calibration	ARM Debug Signal Set
TSTPT(3:0) Capture Value	x0	x8	x1
TSTPT(0)	0	Vertical Sync	ARM9_Debug (0)
TSTPT(1)	0	Delayed CW Index	ARM9_Debug (1)
TSTPT(2)	0	Sequence Index	ARM9_Debug (2)
TSTPT(3)	0	CW Spoke Test Pt	ARM9_Debug (3)
TSTPT(4)	0	CW Revolution Test Pt	ARM9_Debug (4)
TSTPT(5)	0	Reset Seq. Aux Bit 0	ARM9_Debug (5)
TSTPT(6)	0	Reset Seq. Aux Bit 1	ARM9_Debug (6)
TSTPT(7)	0	Reset Seq. Aux Bit 2	ARM9_Debug (7)

7.3.8 Board Level Test Support

The in-circuit tristate enable signal (ICTSEN) is a board level test control signal. By driving ICTSEN to a logic high state, all controller outputs (except TDO1 and TDO2) are tristated.

The DLPC4430 controller also provides JTAG boundary scan support on all I/O except non-digital I/O and a few special signals. [Table 7-5](#) defines these exceptions.

Table 7-5. DLPC4430 —Signals Not Covered by JTAG

SIGNAL NAME	PKG BALL
HW_TEST_EN	M25
MOSC	M26
MOSCN	N26
USB_DAT_N	C5
USB_DAT_P	D6
TCK	N24
TDI	N25
TRSTZ	M23
TDO1	N23
TDO2	N22
TMS1	P25
TMS2	P26

7.4 Device Functional Modes

The DLPC4430 has two functional modes which are enabled via software command via the Host control interface. These modes are Standby and Active.

7.4.1 Standby Mode

The system is powered up and active, however, some blocks within the controller have been shut down to conserve power. Only the μ Processor and its peripherals are active (supporting a dormant projector waiting to be woken up). In this mode the DMD is parked and no image can be displayed.

7.4.2 Active Mode

The system is powered up and fully operational, capable of projecting internal or external video sources.

7.4.2.1 Normal Configuration

This configuration enables the full functionality of the DLPC4430.

8 Application and Implementation

Note

Information in the following applications sections is not part of the TI component specification, and TI does not warrant its accuracy or completeness. TI's customers are responsible for determining suitability of components for their purposes, as well as validating and testing their design implementation to confirm system functionality.

8.1 Application Information

The DLPC4430 display controller coupled with supported DMDs comprise the chipset. The controller integrates all system image processing, DMD control and data formatting onto a single integrated circuit (IC), as well as LED or LPCW illumination systems and multiple image processing algorithms. Applications include Home Theatre, Smart Display, Digital Signage, and Laser TV.

8.2 Typical Application

The DLPC4430 controller is ideal for applications requiring high brightness and high resolution displays. When one DLPC4430 display controller is combined with the DLP DMD, a power management and motor driver device (DLPA100), and other electrical, optical and mechanical components the chipset enables bright, affordable, high resolution display solutions. A typical DLP system application using the DLPC4430 controller and supported DLP DMD is shown below.

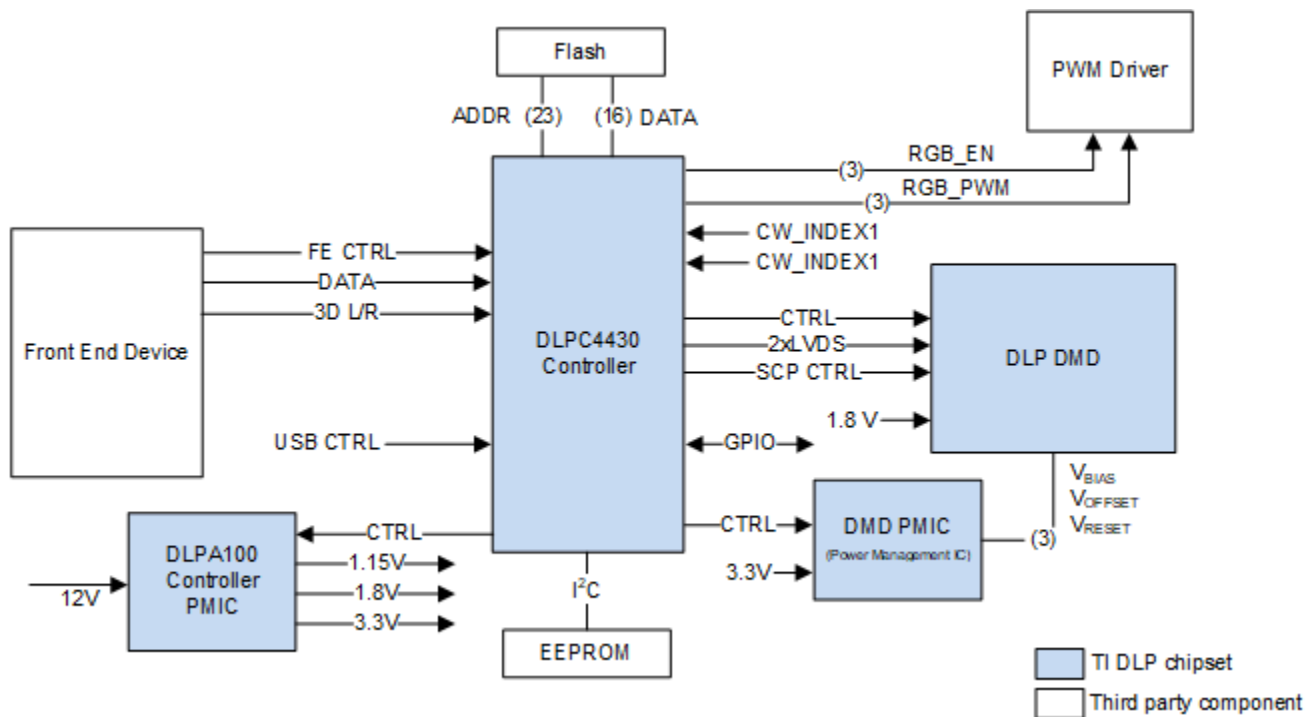

Figure 8-1. Typical LED Display Application

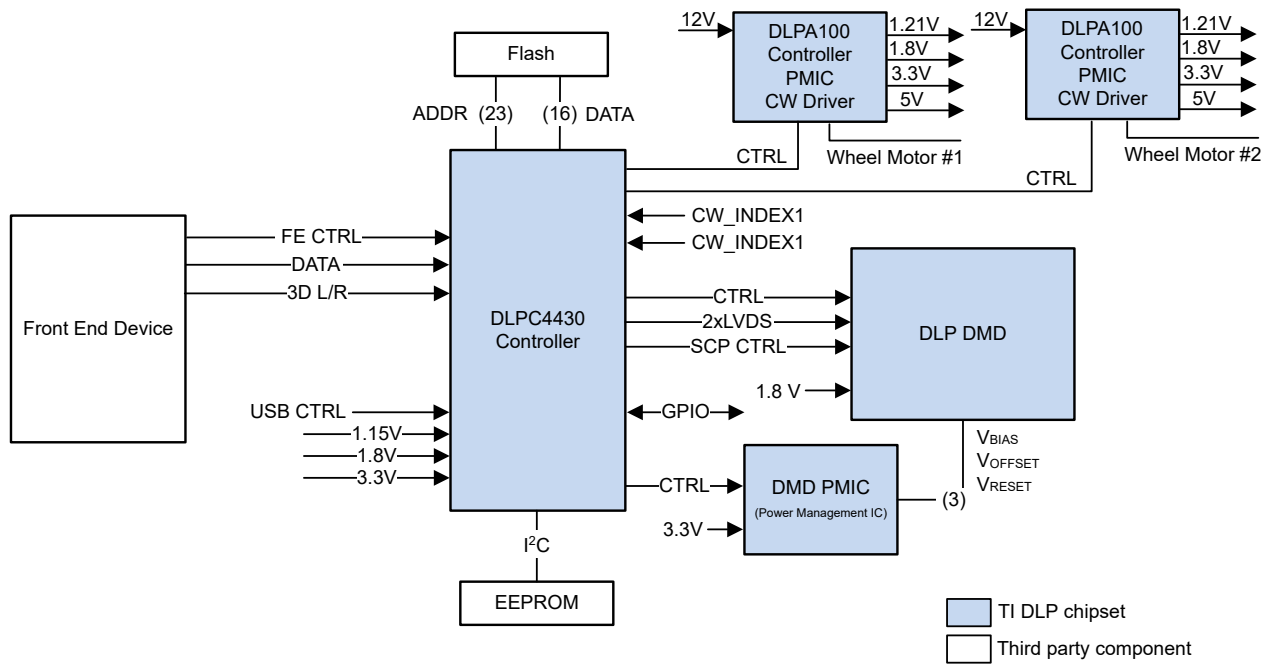

Figure 8-2. Typical LPCW Display Application

8.2.1 Design Requirements

The display controller is the digital interface between the DMD and the rest of the system. The display controller takes digital input from front end digital receivers and drives the DMD over a high speed interface. The display controller also generates the necessary signals (data, protocols, timings) required to display images on the DMD. Some systems require a dual controller to format the incoming data before sending it to the DMD. Reliable operation of the DMD is only insured when the DMD and the controller are used together in a system. In addition to the DLP devices included in the chipset, other devices may be needed such as a flash part to store the software and firmware.

8.2.1.1 Recommended MOSC Crystal Oscillator Configuration

Table 8-1. Crystal Port Characteristics

PARAMETER	NOMINAL	UNIT
MOSC TO GROUND Capacitance	1.5	pF
MOSZ TO GROUND Capacitance	1.5	pF

Table 8-2. Recommended Crystal Configuration

PARAMETER	RECOMMENDED	UNIT
Crystal circuit configuration	Parallel resonant	
Crystal type	Fundamental (1st harmonic)	
Crystal nominal frequency	20	MHz
Crystal frequency temperature stability	+/- 30	PPM
Overall crystal frequency tolerance (including accuracy, stability, aging, and trim sensitivity)	+/- 100	PPM
Crystal Equivalent Series Resistor (ESR)	50 max	Ω
Crystal load	20	pF
Crystal shunt load	7 max	pF
RS drive resistor (nominal)	100	Ω
RFB feedback resistor (nominal)	1	M Ω

Table 8-2. Recommended Crystal Configuration (continued)

PARAMETER	RECOMMENDED	UNIT
CL1 external crystal load capacitor (MOSC)	See (1).	pF
CL2 external crystal load capacitor (MOSCN)	See (1).	pF
PCB layout	A ground isolation ring around the crystal is recommended.	

(1) Typical drive level with the XSA020000FK1H-OCX Crystal (ESR_{max} = 40 Ω) = 50 μW.

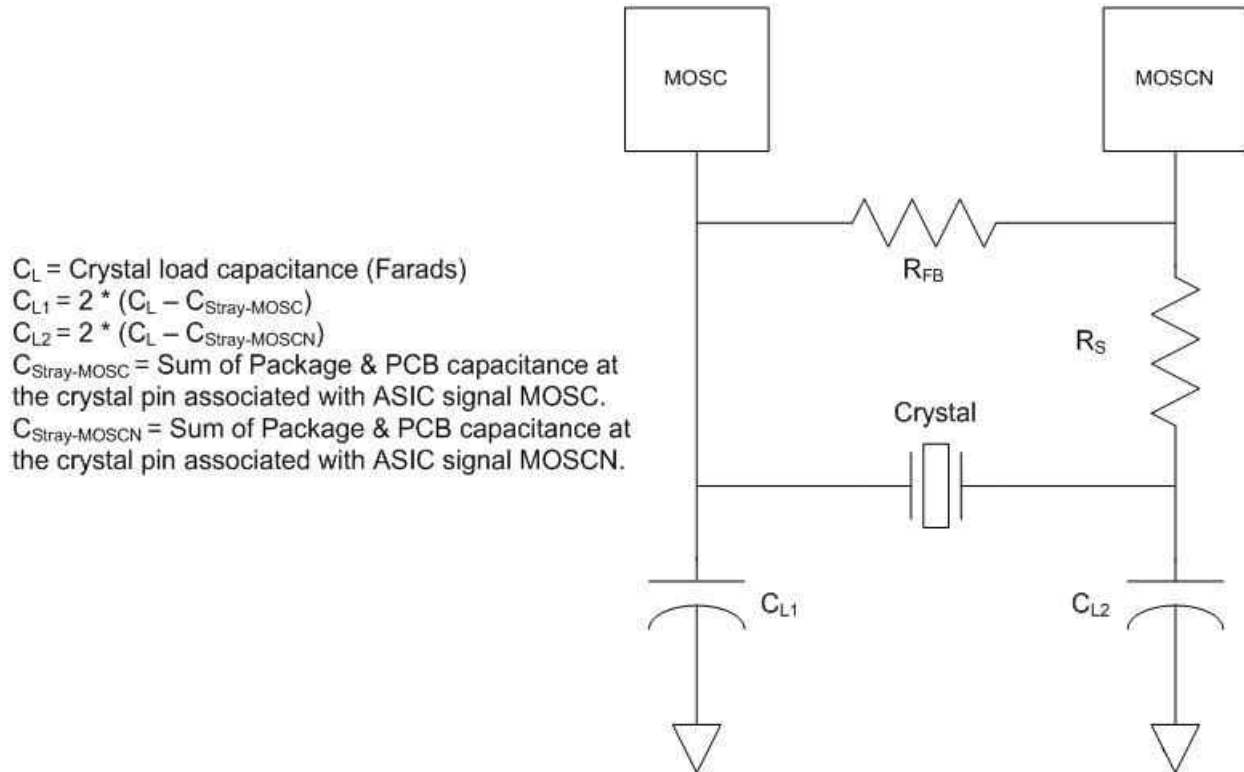
**Figure 8-3. Recommended Crystal Oscillator Configuration**

Typically, the external crystal oscillator stabilizes within 50 ms after stable power is applied.

8.2.2 Detailed Design Procedure

For connecting the DLPC4430 controller and the DLP DMD together, see the reference design schematic. The layout guidelines must be followed to achieve a reliable system. To complete the DLP system, an optical module or light engine is required that contains the DLP DMD, associated illumination sources, optical elements, and necessary mechanical components.

9 Power Supply Recommendations

9.1 System Power Regulations

It is strongly recommended that the VDD18_PLLD, VDD18_PLLM1, and VDD18_PLLM2 power feeding internal PLLs be derived from an isolated linear regulator in order to minimize the AC Noise component. The VDD11_PLLD, VDD11_PLLM1, VDD11_PLLM2, and VDD11_PLLS can be derived from the same regulator as the core VDD11, but they have to be filtered.

9.2 System Power-Up Sequence

Although the DLPC4430 controller requires an array of power supply voltages (1.15V, 1.8V, 3.3V), there are no restrictions regarding the relative order of power supply sequencing for both power-up and power-down scenarios. Similarly, there is no minimum time between powering-up or powering-down the different supplies feeding the DLP controller. However, note that it is not uncommon for there to be power sequencing requirements for the devices that share the supplies with the DLP controller.

- 1.15V core power is applied whenever any I/O power is applied to ensures the state of the associated I/O that are powered are controlled to a known state. Thus, it is recommended to apply core power first. Other supplies are applied only after the 1.1V core has ramped up.
- All DLPC4430 device power must be applied before POSENSE is asserted to ensure proper power-up initialization.

Typically the DLPC4430 controller power-up sequencing is handled by external hardware. An external power monitor will hold the controller in system reset during power-up (i.e. POSENSE = 0). During this time all DLP controller I/Os are tri-stated. The primary PLL (PLL1) is released from reset upon the low to high transition of POSENSE but the controller keeps the rest of the device in reset for an additional 60 ms to allow the PLL to lock and stabilize its outputs. After this 60 ms delay the ARM-9 related internal resets are de-asserted causing the microprocessor to begin its boot-up routine.

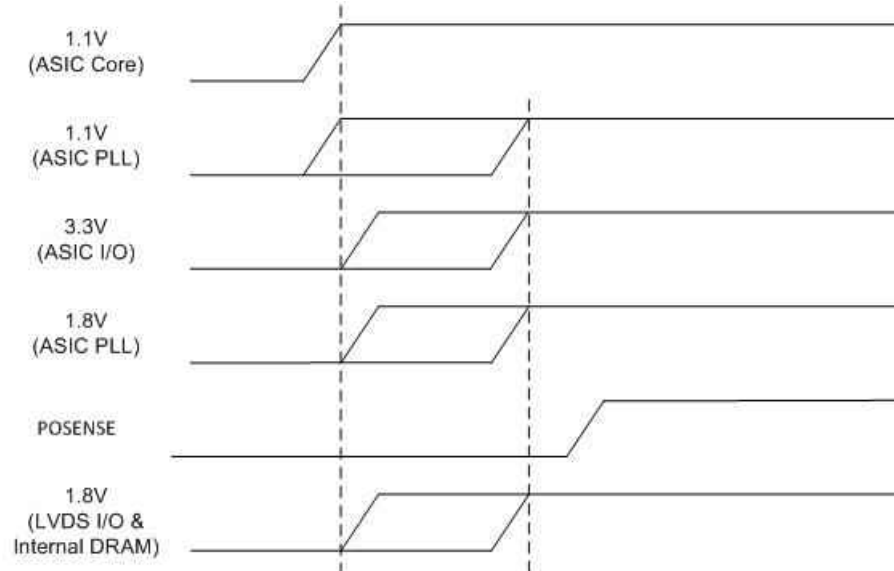

Figure 9-1. System Power-Up Sequence

9.3 Power-On Sense (POSENSE) Support

In order to set up the power monitor to trip within the DLPC4430 controller minimum supply voltage specifications, it is recommended that the external power monitor generating POSENSE targets its threshold to 90% of the minimum supply voltage specifications and ensures that POSENSE remains low a sufficient amount of time for all supply voltages to reach minimum device requirements and stabilize. Note that the trip

voltage for detecting the loss of power, as well as the reaction time to respond to a low voltage condition is not critical for POSENSE as PWRGOOD is used for this purpose. As such, PWRGOOD has critical requirements in these areas.

9.4 System Environment and Defaults

9.4.1 DLPC4430 System Power-Up and Reset Default Conditions

Following system power-up, the DLPC4430 controller performs a power-up initialization routine that defaults the device to a normal power mode, in which ARM9-related clocks are enabled at their full rate and associated resets are released. Most other clocks default to disabled state with associated resets asserted until released by the processor. In addition, the default for system power gating enables all power. These same defaults are also applied as part of all system reset events (Watch Dog timer timeout etc.) that occur without removing or cycling power, with the possible exception of power for the LVDS I/O and internal DRAM. For an extended reset condition, the OEM is expected to place the controller in Low Power mode prior to reset, in which case the 1.8V power for the LVDS I/O and internal DRAM are disabled. When this reset is released, the 1.8V power does not get enabled until the ARM9 has been initialized and is executing the system initialization routines.

Following power-up or system reset initialization, the ARM9 boots from an external flash memory after which it enables the 1.8V power (from the DLPA100), enables the rest of the controller clocks, and initializes the internal DRAM. Once system initialization is complete the Application software determines if and when to enter low power mode.

9.4.2 1.15V System Power

The DLPC4430 controller can support a low cost power delivery system with a single 1.15V power source derived from a switching regulator. To enable this approach, appropriate filtering must be provided for the 1.1V power pins of the PLLs.

9.4.3 1.8V System Power

It is recommended that the DLPC4430 controller power delivery system provides two independent 1.8V power sources. One of the 1.8V power sources is used to supply 1.8V power to the controller LVDS I/O and internal DRAM. Power for these functions is fed from a common source which is recommended to be a linear regulator. The second 1.8V power source is used (along with appropriate filtering as discussed in the PCB layout guidelines for internal ASIC PLL power section of this document) to supply all of the DLPC4430 controller internal PLLs. In order to keep this power as clean as possible, a dedicated linear regulator for the 1.8V power to the PLLs is recommended.

9.4.4 3.3V System Power

The DLPC4430 controller can support a low cost power delivery system with a single 3.3V power source derived from a switching regulator. This 3.3V source supplies power to all LVTTTL I/O and the Crystal Oscillator cell. The 3.3V power must remain active in all power modes for which 1.1V core power is applied.

9.4.5 Power Good (PWRGOOD) Support

The PWRGOOD signal is defined as an early warning signal that alerts the DLPC4430 controller a specified amount of time before the DC supply voltages drop below specifications, which allows the controller to park the DMD and to place the system into reset, ensuring the integrity of future operation. For practical reasons, it is recommended that the monitor sensing PWRGOOD be on the input side of supply regulators.

9.4.6 5V Tolerant Support

With the exception of USB_DAT, the DLPC4430 controller does not support any other 5V tolerant I/Os. However, note that source signals ALF_HSYNC, ALF_VSYNC and I2C typically have 5V requirements and special measures must be taken to support them. Also, 5V to 3.3V level shifter is recommended.

10 Layout

10.1 Layout Guidelines

To achieve the needed thermal connectivity, 2-ounce copper planes in the PCB design are recommended.

10.1.1 PCB Layout Guidelines for Internal DLPC4430 Power

The following guidelines to achieve desired controller performance relative to internal PLLs are recommended:

- The DLPC4430 controller contains four PLLs (PLLM1, PLLM2, PLLD and PLLS), each of which have a dedicated 1.15V digital supply, and three (PLLM1, PLLM2 and PLLD) which have a dedicated 1.8-V analog supply. It is important to have filtering on the supply pins that covers a broad frequency range. Each 1.15V PLL supply pin must have individual high frequency filtering in the form of a ferrite bead and a 0.1 μ F ceramic capacitor. These components must be located very close to the individual PLL supply balls. The impedance of the ferrite bead must be greater than that of the capacitor at frequencies above 10MHz. The 1.15V to the PLL supply pins must also have low frequency filtering in the form of an RC filter. This filter can be common to all the PLLs. The voltage drop across the resistor is limited by the 1.15V regulator tolerance and the DLPC4430 device voltage tolerance. A resistance of 0.36 Ω and a 100 μ F ceramic are recommended.
- The analog 1.8V PLL power pins must have a similar filter topology as the 1.15V. In addition, it is recommended that the 1.8V be generated with a dedicated linear regulator.
- When designing the overall supply filter network, care must be taken to ensure no resonance occurs. Particular care must be taken around the 1 to 2MHz band, as this coincides with the PLL natural loop frequency.

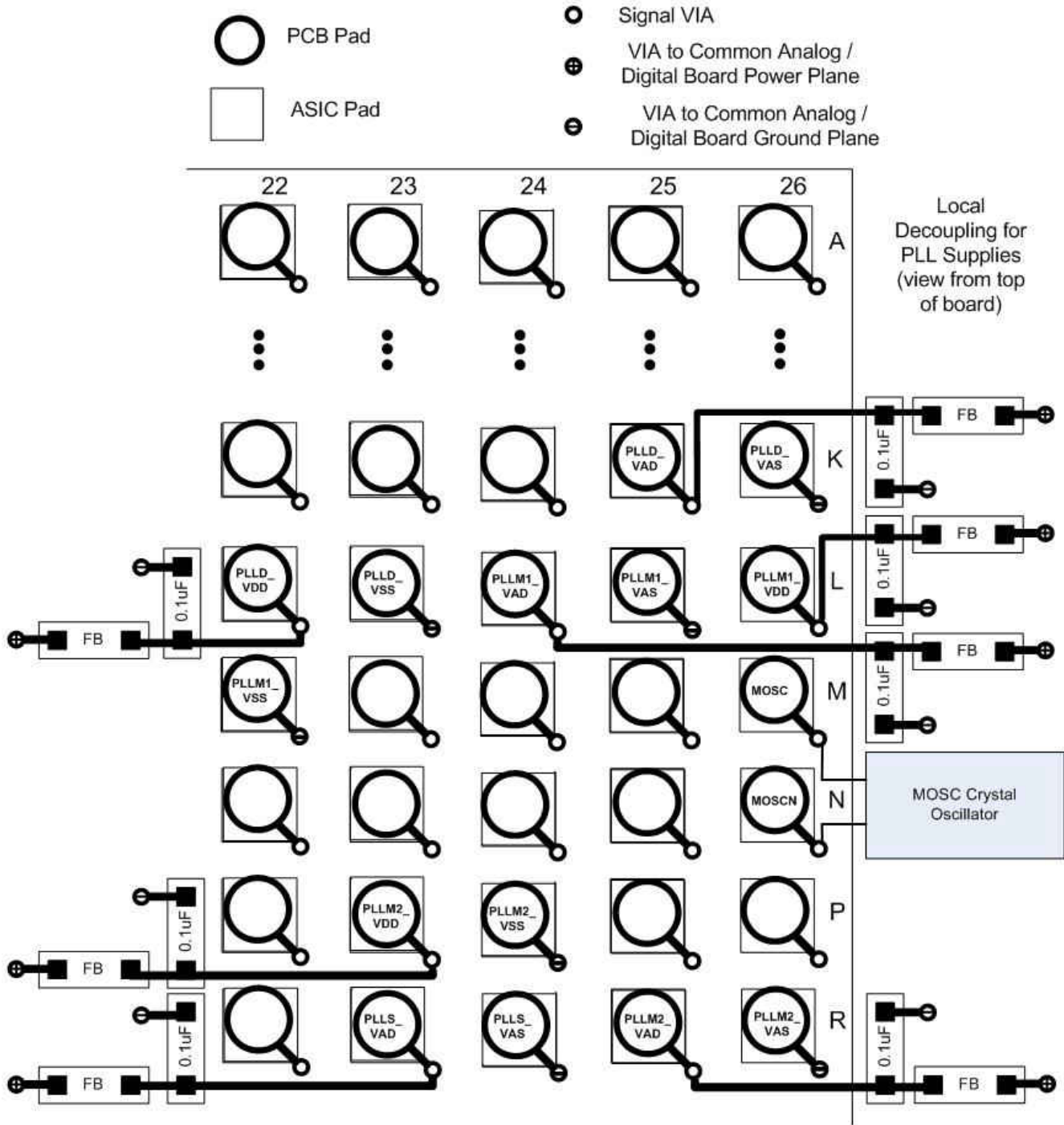

Figure 10-1. PLL Filter Layout

High frequency decoupling is required for both 1.15V and 1.8V PLL supplies and must be provided as close as possible to each of the PLL supply package pins. It is recommended to place decoupling capacitors under the package on the opposite side of the board. Use high quality, low-ESR, monolithic, surface mount capacitors. Typically 0.1µF for each PLL supply is sufficient. The length of a connecting trace increases the parasitic inductance of the mounting and thus, tracing should be avoided, allowing the via to butt up against the land itself. Additionally, the connecting trace has to be made as wide as possible. Further improvement can be made by placing vias to the side of the capacitor lands or doubling the number of vias.

The location of bulk decoupling depends on the system design.

10.1.2 PCB Layout Guidelines for Auto-Lock Performance

One of the most important factors in getting good performance from Auto-Lock is to design the PCB with the highest signal integrity possible by following the recommendations below:

- Place the ADC chip as close to the VESA/Video connectors as possible.
- Avoid crosstalk to the analog signals by keeping them away from digital signals
- Do not place the digital ground or power planes under the analog area between the VESA connector to the ADC chip.
- Avoid crosstalk onto the RGB analog signals, by separating them from the VESA Hsync and Vsync signals.
- Analog power must not be shared with the digital power directly.
- Try to keep the trace lengths of the RGB as equal as possible.
- Use good quality (1%) termination resistors for the RGB inputs to the ADC
- If the green channel must be connected to more than the ADC green input and ADC sync-on-green input, provide a good quality high impedance buffer to avoid adding noise to the green channel.

10.1.3 DMD Interface Considerations

High speed interface waveform quality and timing on the DLPC4430 controller (that is, the LVDS DMD Interface) is dependent on the total length of the interconnect system, the spacing between traces, the characteristic impedance, etch losses, and how well matched the lengths are across the interface. Thus ensuring positive timing margin requires attention to many factors.

As an example, DMD Interface system timing margin can be calculated as follows:

- Setup Margin = (DLPC4430 output setup) – (DMD input setup) – (PCB routing mismatch) – (PCB SI degradation)
- Hold-time Margin = (DLPC4430 output hold) – (DMD input hold) – (PCB routing mismatch) – (PCB SI degradation)

Where *PCB SI degradation* is signal integrity degradation due to PCB effects, which include simultaneously switching output (SSO) noise, cross-talk and inter-symbol interference (ISI) noise. The controller I/O timing parameters as well as DMD I/O timing parameters can be easily found in their corresponding data sheets. Similarly, *PCB routing mismatch* can be budgeted and met through controlled PCB routing. However, PCB SI degradation is not so straight forward.

In an attempt to minimize the signal integrity analysis, the following PCB design guidelines are provided as a reference of an interconnect system that satisfies both waveform quality and timing requirements (accounting for both PCB routing mismatch and PCB SI degradation). Variation from these recommendations may also work, but have to be confirmed with PCB signal integrity analysis or lab measurements

PDB Design:

- | | |
|---------------------------------|---------------------------------|
| • Configuration | Asymmetric Dual Stripline |
| • Etch Thickness | 1.0 oz copper (1.2 mil) |
| • Flex Etch Thickness | 0.5 oz copper (0.6 mil) |
| • Single Ended Signal Impedance | 50 ohms (+/- 10%) |
| • Differential Signal Impedance | 100 ohms differential (+/- 10%) |

PCB Stackup:

- | | |
|--|--------------------|
| • Reference plane 1 is assumed to be a ground plane for proper return path | |
| • Reference plane 2 is assumed to be the I/O power plane or ground | |
| • Dielectric FR4, (Er): | 4.2 (nominal) |
| • Signal trace distance to reference plane 1 (H1) | 5.0 mil (nominal) |
| • Signal trace distance to reference plane 2 (H2) | 34.2 mil (nominal) |

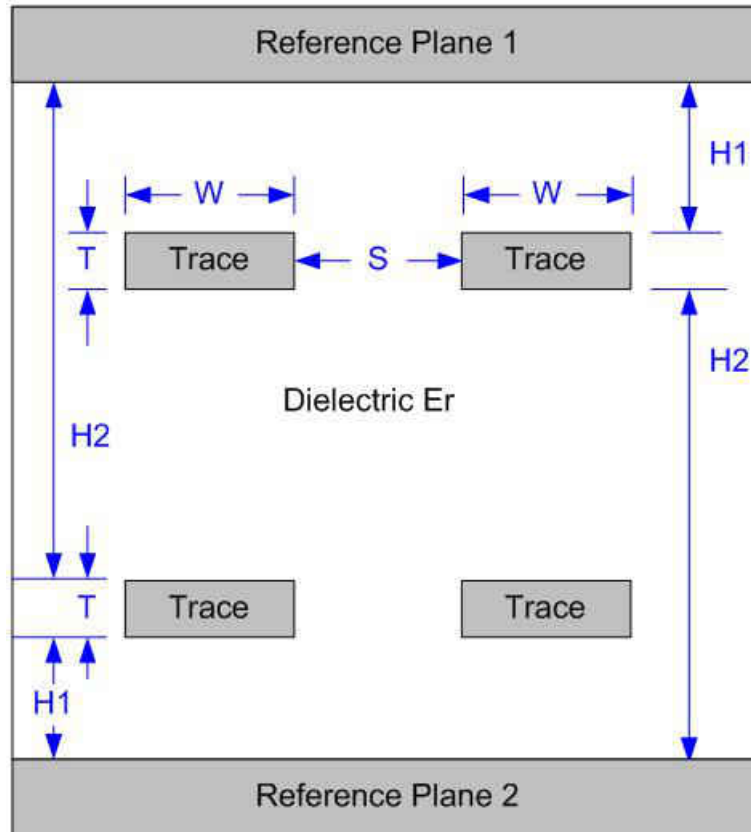

PCB Stackup Geometries

Figure 10-2. PCB Stackup Geometries

Table 10-1. General PCB Routing (Applies to All Corresponding PCB Signals)

PARAMETER	APPLICATION	SINGLE-ENDED SIGNAL	DIFFERENTIAL PAIRS	UNIT
Line width (W) ⁽¹⁾	Escape Routing in Ball Field	4 (0.1)	4 (0.1)	mil (mm)
	PCB Etch Data or Control	7 (0.18)	4.25 (0.11)	mil (mm)
	PCB Etch Clocks	7 (0.18)	4.25 (0.11)	mil (mm)
Minimum Line spacing to other signals (S)	Escape Routing in Ball Field	4 (0.1)	4 (0.1)	mil (mm)
	PCB Etch Data or Control	10 (0.25)	20 (0.51)	mil (mm)
	PCB Etch Clocks	20 (0.51)	20 (0.51)	mil (mm)

(1) Line width is expected to be adjusted to achieve impedance requirements.

Table 10-2. DMD I/F, PCB Interconnect Length Matching Requirements

SIGNAL GROUP LENGTH MATCHING				
I/F	SIGNAL GROUP	REFERENCE SIGNAL	MAX MISMATCH	UNIT
DMD (LVDS)	SCA_P,SCA_N, DDA_P(15:0), DDA_N(15:0)	DCKA_P, DCKA_N	+/-150 (+/-3.81)	mil (mm)
DMD (LVDS)	SCB_P,SCB_N, DDB_P(15:0), DDB_N(15:0)	DCKB_P, DCKB_N	+/-150 (+/-3.81)	mil (mm)

Number of layer changes:

- Single ended signals: Minimize
- Differential signals: Individual differential pairs can be routed on different layers but the signals of a given pair typically does not change layers.

Termination requirements:

- DMD Interface—None, the DMD receiver is differentially terminated to 100 ohms internally

Connector (DMD-LVDS I/F bus only)—High Speed Connectors that meet the following requirements must be used:

- | | |
|--------------------------|------------------|
| • Differential Crosstalk | <5 % |
| • Differential Impedance | 75 ohms–125 ohms |

Routing requirements for right angle connectors:

When using right angle connectors, P-N pairs have to be routed in same row to minimize delay mismatch and propagation delay difference for each row has to be accounted for on associated PCB etch lengths.

10.1.4 Layout Example

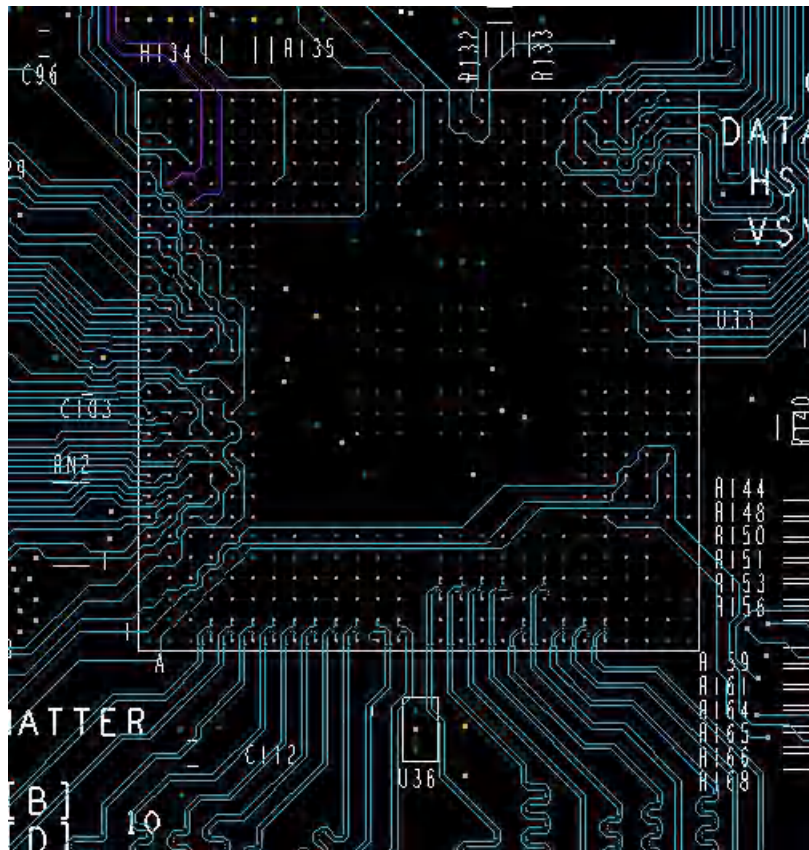

Figure 10-3. Layer 3

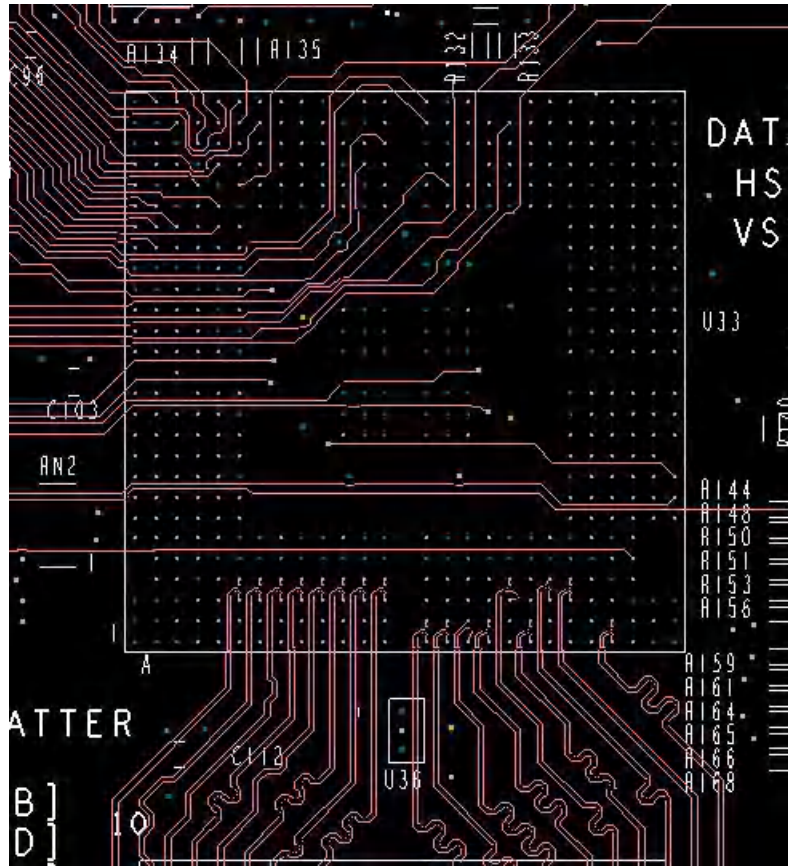

Figure 10-4. Layer 4

10.1.5 Thermal Considerations

The underlying thermal limitation for the DLPC4430 controller is that the maximum operating junction temperature (T_J) not be exceeded (this is defined in the [Section 6.3](#)). This temperature is dependent on operating ambient temperature, airflow, PCB design (including the component layout density and the amount of copper used), power dissipation of the DLPC6421 device and power dissipation of surrounding components. The DLPC4430 package is designed primarily to extract heat through the power and ground planes of the PCB, thus copper content and airflow over the PCB are important factors.

The recommended maximum operating ambient temperature (T_A) is provided primarily as a design target and is based on maximum DLPC4430 power dissipation and $R_{\theta JA}$ at 1 m/s of forced airflow, where $R_{\theta JA}$ is the thermal resistance of the package as measured using a JEDEC defined standard test PCB. This JEDEC test PCB is not necessarily representative of the DLPC4430 PCB, and thus the reported thermal resistance may not be accurate in the actual product application. Although the actual thermal resistance may be different, it is the best information available during the design phase to estimate thermal performance. However, after the PCB is designed and the product is built, it is highly recommended that thermal performance be measured and validated.

To do this, the top center case temperature has to be measured under the worst case product scenario (max power dissipation, max voltage, max ambient temp) and validated not to exceed the maximum recommended case temperature (T_C). This specification is based on the measured ϕ_{JT} for the DLPC4430 package and provides a relatively accurate correlation to junction temperature. Note that care must be taken when measuring this case temperature to prevent accidental cooling of the package surface. A small (approximately 40 gauge) thermocouple is recommended. The bead and the thermocouple wire must contact the top of the package and be covered with a minimal amount of thermally conductive epoxy. The wires must be routed closely along the package and the board surface to avoid cooling the bead through the wires.

11 Device and Documentation Support

11.1 Third-Party Products Disclaimer

TI'S PUBLICATION OF INFORMATION REGARDING THIRD-PARTY PRODUCTS OR SERVICES DOES NOT CONSTITUTE AN ENDORSEMENT REGARDING THE SUITABILITY OF SUCH PRODUCTS OR SERVICES OR A WARRANTY, REPRESENTATION OR ENDORSEMENT OF SUCH PRODUCTS OR SERVICES, EITHER ALONE OR IN COMBINATION WITH ANY TI PRODUCT OR SERVICE.

11.2 Device Support

11.2.1 Video Timing Parameter Definitions

- **Active Lines Per Frame (ALPF)**—Defines the number of lines in a Frame containing displayable data: ALPF is a subset of the TLPF.
- **Active Pixels Per Line (APPL)**—Defines the number of pixel clocks in a line containing displayable data: APPL is a subset of the TPPL
- **Horizontal Back Porch Blanking (HBP)**—Number of blank pixel clocks after Horizontal Sync but before the first active pixel. Note: HBP times are reference to the leading (active) edge of the respective sync signal
- **Horizontal Front Porch Blanking (HFP)**—Number of blank pixel clocks after the last active pixel but before Horizontal Sync.
- **Horizontal Sync (HS)**—Timing reference point that defines the start of each horizontal interval (line). The absolute reference point is defined by the “active” edge of the HS signal. The “active” edge (either rising or falling edge as defined by the source) is the reference from which all Horizontal Blanking parameters are measured.
- **Total Lines Per Frame (TLPF)**—Defines the Vertical Period (or Frame Time) in lines: TLPF = Total number of lines per frame (active and inactive).
- **Total Pixel Per Line (TPPL)**—Defines the Horizontal Line Period in pixel clocks: TPPL = Total number of pixel clocks per line (active and inactive).
- **Vertical Back Porch Blanking (VBP)**—Number of blank lines after Vertical Sync but before the first active line.
- **Vertical Front Porch Blanking (VFP)**—Number of blank lines after the last active line but before Vertical Sync.
- **Vertical Sync (VS)**—Timing reference point that defines the start of the vertical interval (frame). The absolute reference point is defined by the “active” edge of the VS signal. The “active” edge (either rising or falling edge as defined by the source) is the reference from which all Vertical Blanking parameters are measured.

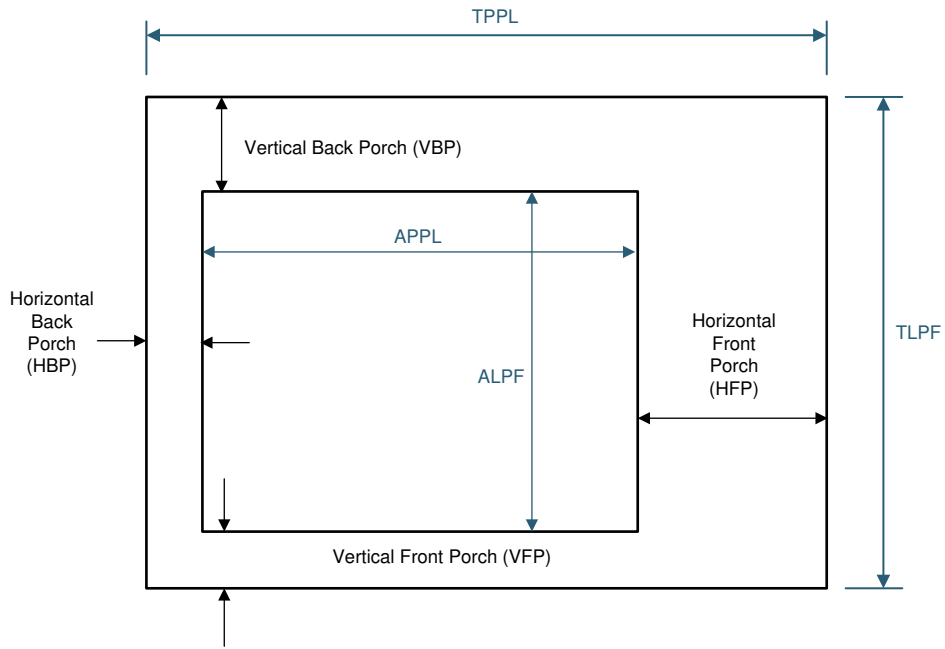

Figure 11-1. Timing Parameter Diagram

11.2.2 Device Nomenclature

Table 11-1. Part Number Description

TI PART NUMBER	DESCRIPTION
DLPC4430	DLPC4430 Digital Controller

11.2.3 Device Markings

11.2.3.1 Device Marking

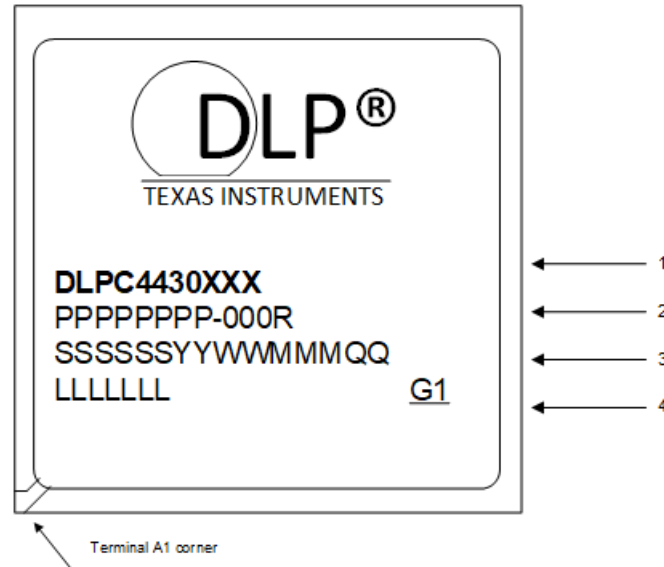

Figure 11-2. DLPC4430 Device Markings

Marking Definitions:

Line 1: DLP Device Name followed by TI Part Number

- XXX: ZPC Package designator

Line 2: Vendor Information

Line 3: SSSSSSYWWMMM-QQ Package Assembly information

- SSSSSS: Vendor Country
- YYWW: Vendor Year and Week Code (YY = Year :: WW = Week)
- MMM: Vendor Manufacturing code (ex. HAL, HBL, HAF)
- QQ: Qualification level (optional)

Line 4: LLLLLLLe1 Manufacturing Information

- LLLLLLL: Manufacturing Lot code
- G1: Green package designator

11.3 Documentation Support

11.3.1 Related Documentation

The following documents contain additional information related to the chipset components used with the DLPC4430:

- [DLPA100 Controller Power Management and Motor Driver Data Sheet](#)
- [DLPA300 DMD Power Management and Motor Driver Data Sheet](#)

11.4 Receiving Notification of Documentation Updates

To receive notification of documentation updates, navigate to the device product folder on [ti.com](https://www.ti.com). Click on *Subscribe to updates* to register and receive a weekly digest of any product information that has changed. For change details, review the revision history included in any revised document.

11.5 Support Resources

TI E2E™ [support forums](#) are an engineer's go-to source for fast, verified answers and design help — straight from the experts. Search existing answers or ask your own question to get the quick design help you need.

Linked content is provided "AS IS" by the respective contributors. They do not constitute TI specifications and do not necessarily reflect TI's views; see TI's [Terms of Use](#).

11.6 Trademarks

ARM946™ is a trademark of ARM.

TI E2E™ is a trademark of Texas Instruments.

DLP® is a registered trademark of Texas Instruments.

All trademarks are the property of their respective owners.

11.7 Electrostatic Discharge Caution



This integrated circuit can be damaged by ESD. Texas Instruments recommends that all integrated circuits be handled with appropriate precautions. Failure to observe proper handling and installation procedures can cause damage.

ESD damage can range from subtle performance degradation to complete device failure. Precision integrated circuits may be more susceptible to damage because very small parametric changes could cause the device not to meet its published specifications.

11.8 Glossary

[TI Glossary](#) This glossary lists and explains terms, acronyms, and definitions.

12 Mechanical, Packaging, and Orderable Information

The following pages include mechanical, packaging, and orderable information. This information is the most current data available for the designated devices. This data is subject to change without notice and revision of this document. For browser-based versions of this data sheet, refer to the left-hand navigation.

PACKAGING INFORMATION

Orderable part number	Status (1)	Material type (2)	Package Pins	Package qty Carrier	RoHS (3)	Lead finish/ Ball material (4)	MSL rating/ Peak reflow (5)	Op temp (°C)	Part marking (6)
DLPC4430ZPC	Active	Production	BGA (ZPC) 516	40 JEDEC TRAY (5+1)	Yes	Call TI	Call TI	0 to 55	

(1) **Status:** For more details on status, see our [product life cycle](#).

(2) **Material type:** When designated, preproduction parts are prototypes/experimental devices, and are not yet approved or released for full production. Testing and final process, including without limitation quality assurance, reliability performance testing, and/or process qualification, may not yet be complete, and this item is subject to further changes or possible discontinuation. If available for ordering, purchases will be subject to an additional waiver at checkout, and are intended for early internal evaluation purposes only. These items are sold without warranties of any kind.

(3) **RoHS values:** Yes, No, RoHS Exempt. See the [TI RoHS Statement](#) for additional information and value definition.

(4) **Lead finish/Ball material:** Parts may have multiple material finish options. Finish options are separated by a vertical ruled line. Lead finish/Ball material values may wrap to two lines if the finish value exceeds the maximum column width.

(5) **MSL rating/Peak reflow:** The moisture sensitivity level ratings and peak solder (reflow) temperatures. In the event that a part has multiple moisture sensitivity ratings, only the lowest level per JEDEC standards is shown. Refer to the shipping label for the actual reflow temperature that will be used to mount the part to the printed circuit board.

(6) **Part marking:** There may be an additional marking, which relates to the logo, the lot trace code information, or the environmental category of the part.

Multiple part markings will be inside parentheses. Only one part marking contained in parentheses and separated by a "~" will appear on a part. If a line is indented then it is a continuation of the previous line and the two combined represent the entire part marking for that device.

Important Information and Disclaimer: The information provided on this page represents TI's knowledge and belief as of the date that it is provided. TI bases its knowledge and belief on information provided by third parties, and makes no representation or warranty as to the accuracy of such information. Efforts are underway to better integrate information from third parties. TI has taken and continues to take reasonable steps to provide representative and accurate information but may not have conducted destructive testing or chemical analysis on incoming materials and chemicals. TI and TI suppliers consider certain information to be proprietary, and thus CAS numbers and other limited information may not be available for release.

In no event shall TI's liability arising out of such information exceed the total purchase price of the TI part(s) at issue in this document sold by TI to Customer on an annual basis.

ZPC (S-PBGA-N516)

PLASTIC BALL GRID ARRAY

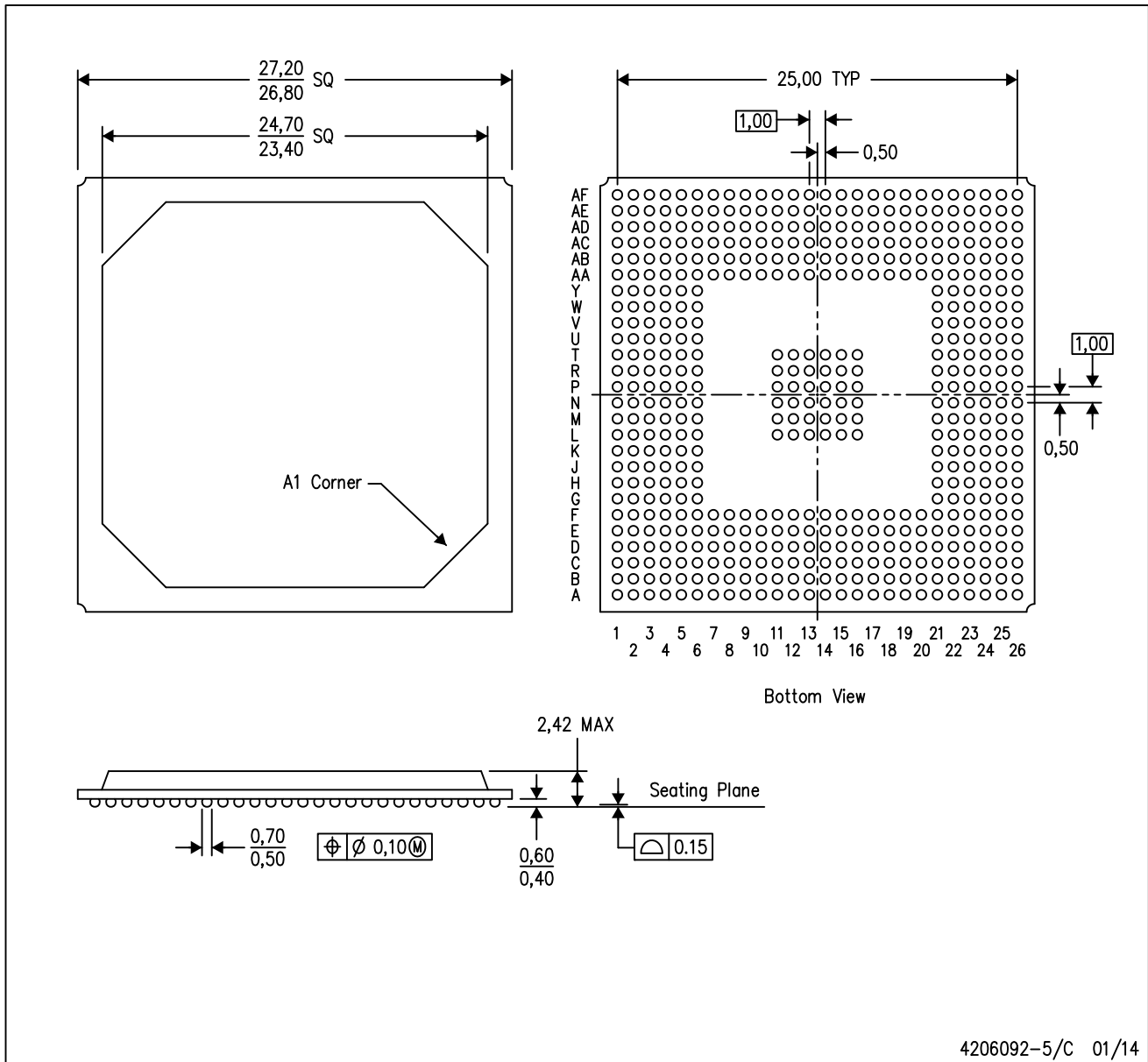

- NOTES:
- A. All linear dimensions are in millimeters.
 - B. This drawing is subject to change without notice.
 - C. This package is Pb-free.

IMPORTANT NOTICE AND DISCLAIMER

TI PROVIDES TECHNICAL AND RELIABILITY DATA (INCLUDING DATASHEETS), DESIGN RESOURCES (INCLUDING REFERENCE DESIGNS), APPLICATION OR OTHER DESIGN ADVICE, WEB TOOLS, SAFETY INFORMATION, AND OTHER RESOURCES "AS IS" AND WITH ALL FAULTS, AND DISCLAIMS ALL WARRANTIES, EXPRESS AND IMPLIED, INCLUDING WITHOUT LIMITATION ANY IMPLIED WARRANTIES OF MERCHANTABILITY, FITNESS FOR A PARTICULAR PURPOSE OR NON-INFRINGEMENT OF THIRD PARTY INTELLECTUAL PROPERTY RIGHTS.

These resources are intended for skilled developers designing with TI products. You are solely responsible for (1) selecting the appropriate TI products for your application, (2) designing, validating and testing your application, and (3) ensuring your application meets applicable standards, and any other safety, security, regulatory or other requirements.

These resources are subject to change without notice. TI grants you permission to use these resources only for development of an application that uses the TI products described in the resource. Other reproduction and display of these resources is prohibited. No license is granted to any other TI intellectual property right or to any third party intellectual property right. TI disclaims responsibility for, and you fully indemnify TI and its representatives against any claims, damages, costs, losses, and liabilities arising out of your use of these resources.

TI's products are provided subject to [TI's Terms of Sale](#), [TI's General Quality Guidelines](#), or other applicable terms available either on [ti.com](#) or provided in conjunction with such TI products. TI's provision of these resources does not expand or otherwise alter TI's applicable warranties or warranty disclaimers for TI products. Unless TI explicitly designates a product as custom or customer-specified, TI products are standard, catalog, general purpose devices.

TI objects to and rejects any additional or different terms you may propose.

Copyright © 2025, Texas Instruments Incorporated

Last updated 10/2025