

SNx4AHC125 Quadruple Bus Buffer Gates With 3-State Outputs

1 Features

- Operating range of 2V to 5.5V
- Latch-up performance exceeds 250mA per JESD 17
- Four individual output enable pins

2 Applications

- Flow Meters
- Programmable Logic Controllers
- Power Over Ethernet (PoE)
- Motor Drives and Controls
- Electronic Point-of-Sale

3 Description

The SNx4AHC125 devices are quadruple bus buffer gates featuring independent line drivers with 3-state outputs. Each output is disabled when the associated output-enable (\overline{OE}) input is high. When \overline{OE} is low, the respective gate passes the data from the A input to its Y output.

To ensure the high-impedance state during power up or power down, \overline{OE} must be tied to V_{CC} through a pullup resistor; the minimum value of the resistor is determined by the current-sinking capability of the driver.

Device Information

PART NUMBER	PACKAGE ⁽¹⁾	BODY SIZE ⁽²⁾
SN54AHC125	J (CDIP, 14)	8.89mm 8.89mm
	W (CFP, 14)	19.56mm × 6.67mm
	FK (LCCC, 20)	9.21mm × 5.97mm
SN74AHC125	DB (SSOP, 14)	6.20mm 5.30mm
	D (SOIC, 14)	8.65mm × 3.91mm
	NS (SO, 14)	10.30mm × 5.30mm
	DGV (TVSOP, 14)	3.60mm × 4.40mm
	PW (TSSOP, 14)	5.00mm × 4.40mm
	N (PDIP, 14)	19.30mm × 6.35mm
	RGY (VQFN, 14)	3.50mm × 3.50mm
BQA (WQFN, 14)	3mm × 2.5mm	

(1) For more information, see [Section 11](#).

(2) The body size (length × width) is a nominal value and does not include pins.

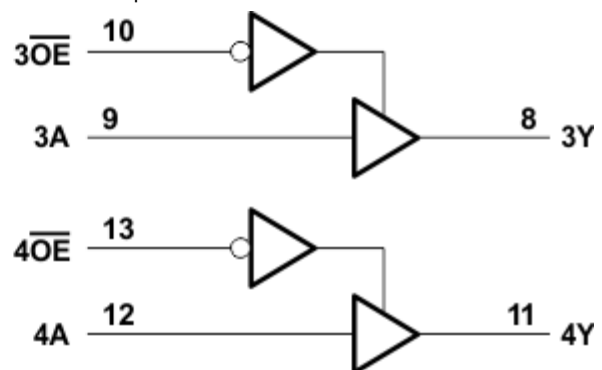
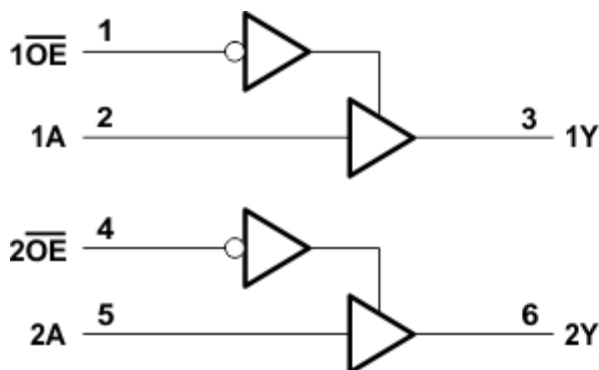

Pin numbers shown are for the D, DB, DGV, J, N, NS, PW, RGY, and W packages.

Logic Diagram (Positive Logic)



Table of Contents

1 Features	1	7.2 Functional Block Diagram.....	12
2 Applications	1	7.3 Feature Description.....	12
3 Description	1	7.4 Device Functional Modes.....	12
4 Pin Configuration and Functions	3	8 Application and Implementation	13
5 Specifications	5	8.1 Application Information.....	13
5.1 Absolute Maximum Ratings.....	5	8.2 Typical Application.....	13
5.2 ESD Ratings.....	5	8.3 Power Supply Recommendations.....	15
5.3 Recommended Operating Conditions.....	5	8.4 Layout.....	15
5.4 Thermal Information.....	6	9 Device and Documentation Support	16
5.5 Electrical Characteristics.....	6	9.1 Documentation Support (Analog).....	16
5.6 Switching Characteristics, $V_{CC} = 3.3\text{ V} \pm 0.3\text{ V}$	8	9.2 Receiving Notification of Documentation Updates....	16
5.7 Switching Characteristics, $V_{CC} = 5\text{ V} \pm 0.5\text{ V}$	9	9.3 Support Resources.....	16
5.8 Noise Characteristics.....	10	9.4 Trademarks.....	16
5.9 Operating Characteristics.....	10	9.5 Electrostatic Discharge Caution.....	16
5.10 Typical Characteristics.....	10	9.6 Glossary.....	16
6 Parameter Measurement Information	11	10 Revision History	16
7 Detailed Description	12	11 Mechanical, Packaging, and Orderable Information	17
7.1 Overview.....	12		

4 Pin Configuration and Functions

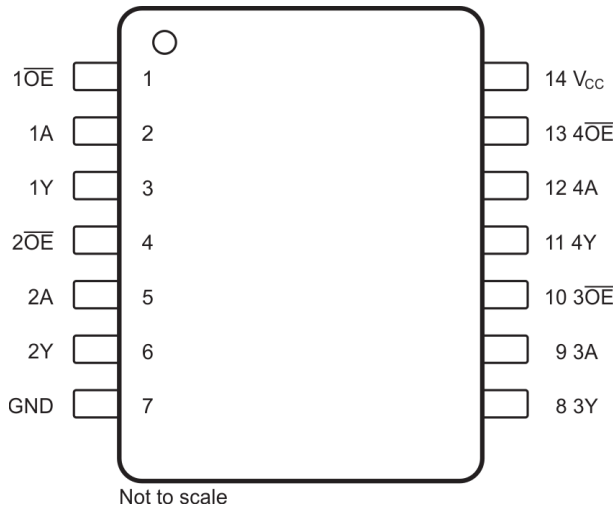

Not to scale

**Figure 4-1. D, DB, DGV, N, NS, J, W, or PW Package
 14-Pin SOIC, SSOP, TVSOP, PDIP, SO, CDIP, CFP, or
 TSSOP Top View**

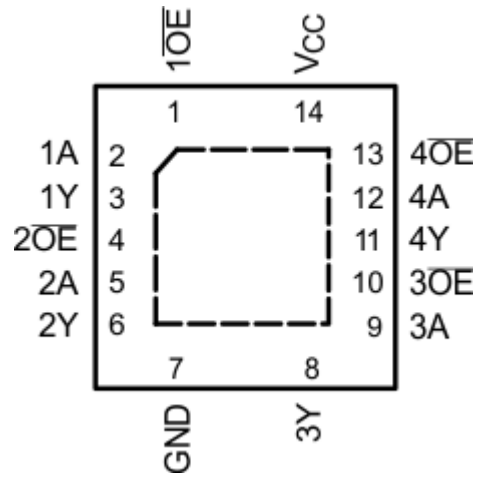

**Figure 4-2. RGY or BQA Package 14-Pin VQFN Top
 View**

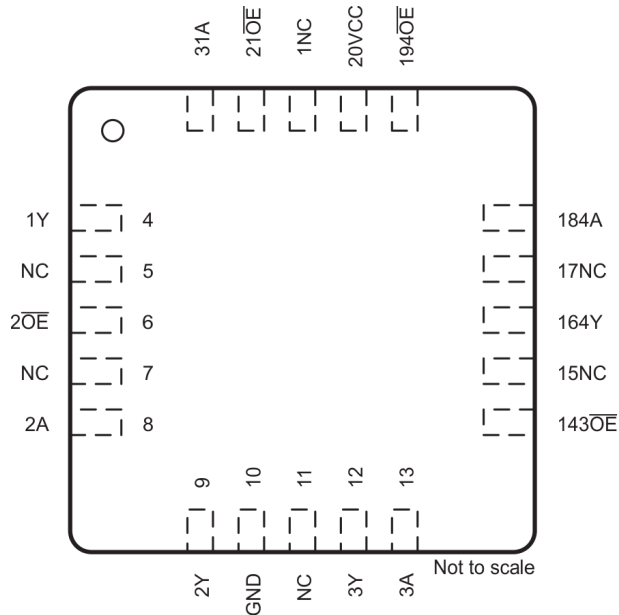

Not to scale

Figure 4-3. FK Package 20-Pin LCCC Top View

Table 4-1. Pin Functions

NAME	PIN		I/O	DESCRIPTION
	SOIC, SSOP, TVSOP, PDIP, SO, CDIP, CFP, TSSOP, VQFN	LCCC		
1 \overline{OE}	1	2	I	Output enable for gate 1
1A	2	3	I	Gate 1 input
1Y	3	4	O	Gate 1 output
2 \overline{OE}	4	6	I	Output enable for gate 2
2A	5	8	I	Gate 2 input
2Y	6	9	O	Gate 2 output
3 \overline{OE}	10	14	I	Output enable for gate 3
3A	9	13	I	Gate 3 input
3Y	8	12	O	Gate 3 output
4 \overline{OE}	13	19	I	Output enable for gate 4
4A	12	18	I	Gate 4 input
4Y	11	16	O	Gate 4 output
GND	7	10	—	Ground pin
NC	—	1, 5, 7, 11, 15, 17	—	No internal connection
V _{CC}	14	20	—	Power pin

5 Specifications

5.1 Absolute Maximum Ratings

over operating free-air temperature range (unless otherwise noted)⁽¹⁾

		MIN	MAX	UNIT
Supply voltage		-0.5	7	V
Input voltage ⁽²⁾		-0.5	7	V
Output voltage ⁽²⁾		-0.5	$V_{CC} + 0.5$	V
Input clamp current	$V_I < 0$		-20	mA
Output clamp current	$V_O < 0$ or $V_O > V_{CC}$		±20	mA
Continuous output current	$V_O = 0$ to V_{CC}		±25	mA
Continuous current through V_{CC} or GND			±50	mA
Virtual operating junction temperature, T_J			150	°C
Storage temperature, T_{stg}		-65	150	°C

- (1) Stresses beyond those listed under *Absolute Maximum Ratings* may cause permanent damage to the device. These are stress ratings only, which do not imply functional operation of the device at these or any other conditions beyond those indicated under *Recommended Operating Conditions*. Exposure to absolute-maximum-rated conditions for extended periods may affect device reliability.
- (2) The input and output voltage ratings may be exceeded if the input and output current ratings are observed.

5.2 ESD Ratings

		VALUE	UNIT
$V_{(ESD)}$	Electrostatic discharge	Human-body model (HBM), per ANSI/ESDA/JEDEC JS-001 ⁽¹⁾	±1500
		Charged-device model (CDM), per JEDEC specification JESD22-C101 ⁽²⁾	±1000

- (1) JEDEC document JEP155 states that 500-V HBM allows safe manufacturing with a standard ESD control process.
- (2) JEDEC document JEP157 states that 250-V CDM allows safe manufacturing with a standard ESD control process.

5.3 Recommended Operating Conditions

over operating free-air temperature range (unless otherwise noted)

		MIN	MAX	UNIT
V_{CC}	Supply voltage	2	5.5	V
V_{IH}	High-level input voltage	$V_{CC} = 2\text{ V}$	1.5	V
		$V_{CC} = 3\text{ V}$	2.1	
		$V_{CC} = 5.5\text{ V}$	3.85	
V_{IL}	Low-level Input voltage	$V_{CC} = 2\text{ V}$	0.5	V
		$V_{CC} = 3\text{ V}$	0.9	
		$V_{CC} = 5.5\text{ V}$	1.65	
V_I	Input voltage	0	5.5	V
V_O	Output voltage	0	V_{CC}	V
I_{OH}	High-level output current	$V_{CC} = 2\text{ V}$	-50	μA
		$V_{CC} = 3.3\text{ V} \pm 0.3\text{ V}$	-4	mA
		$V_{CC} = 5\text{ V} \pm 0.5\text{ V}$	-8	
I_{OL}	Low-level output current	$V_{CC} = 2\text{ V}$	50	μA
		$V_{CC} = 3.3\text{ V} \pm 0.3\text{ V}$	4	mA
		$V_{CC} = 5\text{ V} \pm 0.5\text{ V}$	8	
$\Delta t/\Delta v$	Input Transition rise or fall rate	$V_{CC} = 3.3\text{ V} \pm 0.3\text{ V}$	100	ns/V
		$V_{CC} = 5\text{ V} \pm 0.5\text{ V}$	20	
T_A	Operating free-air temperature	-40	125	°C

5.4 Thermal Information

THERMAL METRIC ⁽¹⁾		SNx4AHC125								UNIT
		D (SOIC)	DB (SSOP)	NS (SO)	DGV (TVSOP)	PW (TSSOP)	N (PDIP)	RGY (VQFN)	BQA (WQFN)	
		14 PINS	14 PINS	14 PINS	14 PINS	14 PINS	14 PINS	14 PINS	14 PINS	
R _{θJA}	Junction-to-ambient thermal resistance	124.5	107.3	89.9	134.6	147.7	56.3	87.1	88.3	°C/W
R _{θJC(top)}	Junction-to-case (top) thermal resistance	78.8	59.3	47.7	53.9	77.4	43.9	92.6	90.9	°C/W
R _{θJB}	Junction-to-board thermal resistance	81	54.7	48.6	63.8	90.9	36.1	62.5	56.8	°C/W
ψ _{JT}	Junction-to-top characterization parameter	37	24	17.5	6.3	27.2	29.2	22.8	9.9	°C/W
ψ _{JB}	Junction-to-board characterization parameter	80.6	54.1	48.3	63.2	90.2	36	61.7	56.7	°C/W
R _{θJC(bot)}	Junction-to-case (bottom) thermal resistance	N/A	N/A	N/A	N/A	N/A	N/A	45.1	33.4	°C/W

- (1) For more information about traditional and new thermal metrics, see the [Semiconductor and IC Package Thermal Metrics](#) application report.

5.5 Electrical Characteristics

over recommended operating free-air temperature range (unless otherwise noted)

PARAMETER	TEST CONDITIONS			MIN	TYP	MAX	UNIT
V _{OH}	I _{OH} = -50 μA	V _{CC} = 2 V	T _A = 25°C	1.9	2	V	
			T _A = -55°C to 125°C (SN54AHC125)	1.9			
			T _A = -40°C to 85°C (SN74AHC125)	1.9			
			T _A = -40°C to 125°C (recommended SN74AHC125)	1.9			
		V _{CC} = 3 V	T _A = 25°C	2.9	3		
			T _A = -55°C to 125°C (SN54AHC125)	2.9			
			T _A = -40°C to 85°C (SN74AHC125)	2.9			
			T _A = -40°C to 125°C (recommended SN74AHC125)	2.9			
		V _{CC} = 4.5 V	T _A = 25°C	4.4	4.5		
			T _A = -55°C to 125°C (SN54AHC125)	4.4			
			T _A = -40°C to 85°C (SN74AHC125)	4.4			
			T _A = -40°C to 125°C (recommended SN74AHC125)	4.4			
	I _{OH} = -4 mA and V _{CC} = 3 V	T _A = 25°C	2.58				
		T _A = -55°C to 125°C (SN54AHC125)	2.48				
		T _A = -40°C to 85°C (SN74AHC125)	2.48				
		T _A = -40°C to 125°C (recommended SN74AHC125)	2.48				
I _{OH} = -8 mA and V _{CC} = 4.5 V	T _A = 25°C	3.94					
	T _A = -55°C to 125°C (SN54AHC125)	3.8					
	T _A = -40°C to 85°C (SN74AHC125)	3.8					
	T _A = -40°C to 125°C (recommended SN74AHC125)	3.8					

5.5 Electrical Characteristics (continued)

over recommended operating free-air temperature range (unless otherwise noted)

PARAMETER	TEST CONDITIONS		MIN	TYP	MAX	UNIT
V_{OL}	$I_{OL} = 50 \mu A$	$V_{CC} = 2 V$	$T_A = 25^\circ C$		0.1	V
			$T_A = -55^\circ C$ to $125^\circ C$ (SN54AHC125)		0.1	
			$T_A = -40^\circ C$ to $85^\circ C$ (SN74AHC125)		0.1	
			$T_A = -40^\circ C$ to $125^\circ C$ (recommended SN74AHC125)		0.1	
		$V_{CC} = 3 V$	$T_A = 25^\circ C$		0.1	
			$T_A = -55^\circ C$ to $125^\circ C$ (SN54AHC125)		0.1	
			$T_A = -40^\circ C$ to $85^\circ C$ (SN74AHC125)		0.1	
			$T_A = -40^\circ C$ to $125^\circ C$ (recommended SN74AHC125)		0.1	
		$V_{CC} = 4.5 V$	$T_A = 25^\circ C$		0.1	
			$T_A = -55^\circ C$ to $125^\circ C$ (SN54AHC125)		0.1	
			$T_A = -40^\circ C$ to $85^\circ C$ (SN74AHC125)		0.1	
			$T_A = -40^\circ C$ to $125^\circ C$ (recommended SN74AHC125)		0.1	
	$I_{OH} = 4 mA$ and $V_{CC} = 3 V$	$T_A = 25^\circ C$		0.36		
		$T_A = -55^\circ C$ to $125^\circ C$ (SN54AHC125)		0.5		
		$T_A = -40^\circ C$ to $85^\circ C$ (SN74AHC125)		0.44		
		$T_A = -40^\circ C$ to $125^\circ C$ (recommended SN74AHC125)		0.5		
$I_{OH} = 8 mA$ and $V_{CC} = 4.5 V$	$T_A = 25^\circ C$		0.36			
	$T_A = -55^\circ C$ to $125^\circ C$ (SN54AHC125)		0.5			
	$T_A = -40^\circ C$ to $85^\circ C$ (SN74AHC125)		0.44			
	$T_A = -40^\circ C$ to $125^\circ C$ (recommended SN74AHC125)		0.5			
I_I	$V_I = 5.5 V$ or GND and $V_{CC} = 0 V$ to $5.5 V$	$T_A = 25^\circ C$		± 0.1	μA	
		$T_A = -55^\circ C$ to $125^\circ C$ (SN54AHC125)		$\pm 1^{(1)}$		
		$T_A = -40^\circ C$ to $85^\circ C$ (SN74AHC125)		± 1		
		$T_A = -40^\circ C$ to $125^\circ C$ (recommended SN74AHC125)		± 1		
I_{OZ}	$V_O = V_{CC}$ or GND and $V_{CC} = 5.5 V$	$T_A = 25^\circ C$		± 0.25	μA	
		$T_A = -55^\circ C$ to $125^\circ C$ (SN54AHC125)		± 2.5		
		$T_A = -40^\circ C$ to $85^\circ C$ (SN74AHC125)		± 2.5		
		$T_A = -40^\circ C$ to $125^\circ C$ (recommended SN74AHC125)		± 2.5		
I_{CC}	$V_I = V_{CC}$ or GND, $I_O = 0$, and $V_{CC} = 5.5 V$	$T_A = 25^\circ C$		4	μA	
		$T_A = -55^\circ C$ to $125^\circ C$ (SN54AHC125)		40		
		$T_A = -40^\circ C$ to $85^\circ C$ (SN74AHC125)		40		
		$T_A = -40^\circ C$ to $125^\circ C$ (recommended SN74AHC125)		40		
C_i	$V_I = V_{CC}$ or GND and $V_{CC} = 5 V$	$T_A = 25^\circ C$		4	pF	
		$T_A = -40^\circ C$ to $85^\circ C$ (SN74AHC125)		10		

(1) On products compliant to MIL-PRF-38535, this parameter is not production tested at $V_{CC} = 0 V$.

5.6 Switching Characteristics, $V_{CC} = 3.3\text{ V} \pm 0.3\text{ V}$

over recommended operating free-air temperature range and $V_{CC} = 3.3\text{ V} \pm 0.3\text{ V}$ (unless otherwise noted; see [Load Circuit and Voltage Waveforms](#))

PARAMETER	FROM (INPUT)	TO (OUTPUT)	TEST CONDITIONS		MIN	TYP	MAX	UNIT
t_{PHL} , t_{PLH}	A	Y	$C_L = 15\text{ pF}$	$T_A = 25^\circ\text{C}$		5.6 ⁽¹⁾	8 ⁽¹⁾	ns
				$T_A = -55^\circ\text{C}$ to 125°C (SN54AHC125)	1 ⁽¹⁾		9.5 ⁽¹⁾	
				$T_A = -40^\circ\text{C}$ to 85°C (SN74AHC125)	1		9.5	
				$T_A = -40^\circ\text{C}$ to 125°C (recommended SN74AHC125)	1		9.5	
t_{PZL} , t_{PZH}	\overline{OE}	Y	$C_L = 15\text{ pF}$	$T_A = 25^\circ\text{C}$		5.4 ⁽¹⁾	8 ⁽¹⁾	ns
				$T_A = -55^\circ\text{C}$ to 125°C (SN54AHC125)	1 ⁽¹⁾		9.5 ⁽¹⁾	
				$T_A = -40^\circ\text{C}$ to 85°C (SN74AHC125)			9.5	
				$T_A = -40^\circ\text{C}$ to 125°C (recommended SN74AHC125)			9.5	
t_{PLZ} , t_{PHZ}	\overline{OE}	Y	$C_L = 15\text{ pF}$	$T_A = 25^\circ\text{C}$		7.0 ⁽¹⁾	9.7 ⁽¹⁾	ns
				$T_A = -55^\circ\text{C}$ to 125°C (SN54AHC125)	1 ⁽¹⁾		11.5 ⁽¹⁾	
				$T_A = -40^\circ\text{C}$ to 85°C (SN74AHC125)	1 ⁽¹⁾		11.5 ⁽¹⁾	
				$T_A = -40^\circ\text{C}$ to 125°C (recommended SN74AHC125)	1 ⁽¹⁾		11.5 ⁽¹⁾	
t_{PHL} , t_{PLH}	A	Y	$C_L = 50\text{ pF}$	$T_A = 25^\circ\text{C}$		8.1	11.5	ns
				$T_A = -55^\circ\text{C}$ to 125°C (SN54AHC125)	1		13	
				$T_A = -40^\circ\text{C}$ to 85°C (SN74AHC125)	1		13	
				$T_A = -40^\circ\text{C}$ to 125°C (recommended SN74AHC125)	1		13	
t_{PZL} , t_{PZH}	\overline{OE}	Y	$C_L = 50\text{ pF}$	$T_A = 25^\circ\text{C}$		7.9	11.5	ns
				$T_A = -55^\circ\text{C}$ to 125°C (SN54AHC125)	1		13	
				$T_A = -40^\circ\text{C}$ to 85°C (SN74AHC125)	1		13	
				$T_A = -40^\circ\text{C}$ to 125°C (recommended SN74AHC125)	1		13	
t_{PLZ} , t_{PHZ}	\overline{OE}	Y	$C_L = 50\text{ pF}$	$T_A = 25^\circ\text{C}$		9.5	13.2	ns
				$T_A = -55^\circ\text{C}$ to 125°C (SN54AHC125)	1		15	
				$T_A = -40^\circ\text{C}$ to 85°C (SN74AHC125)	1		15	
				$T_A = -40^\circ\text{C}$ to 125°C (recommended SN74AHC125)	1		15	
$t_{sk(o)}$	\overline{OE}	Y	$C_L = 50\text{ pF}$	$T_A = 25^\circ\text{C}$			1.5 ⁽²⁾	ns
				$T_A = -40^\circ\text{C}$ to 85°C (SN74AHC125)			1.5	

(1) On products compliant to MIL-PRF-38535, this parameter is not production tested.

(2) On products compliant to MIL-PRF-38535, this parameter does not apply.

5.7 Switching Characteristics, $V_{CC} = 5\text{ V} \pm 0.5\text{ V}$

over recommended operating free-air temperature range and $V_{CC} = 5\text{ V} \pm 0.5\text{ V}$ (unless otherwise noted; see [Load Circuit and Voltage Waveforms](#))

PARAMETER	FROM (INPUT)	TO (OUTPUT)	TEST CONDITIONS		MIN	TYP	MAX	UNIT
t_{PLH} , t_{PHL}	A	Y	$C_L = 15\text{ pF}$	$T_A = 25^\circ\text{C}$		3.8 ⁽¹⁾	5.5 ⁽¹⁾	ns
				$T_A = -55^\circ\text{C}$ to 125°C (SN54AHC125)	1 ⁽¹⁾		6.5 ⁽¹⁾	
				$T_A = -40^\circ\text{C}$ to 85°C (SN74AHC125)	1		6.5	
				$T_A = -40^\circ\text{C}$ to 125°C (recommended SN74AHC125)	1		6.5	
t_{PZH} , t_{PZL}	\overline{OE}	Y	$C_L = 15\text{ pF}$	$T_A = 25^\circ\text{C}$		3.6 ⁽¹⁾	5.1 ⁽¹⁾	ns
				$T_A = -55^\circ\text{C}$ to 125°C (SN54AHC125)	1 ⁽¹⁾		6 ⁽¹⁾	
				$T_A = -40^\circ\text{C}$ to 85°C (SN74AHC125)	1		6	
				$T_A = -40^\circ\text{C}$ to 125°C (recommended SN74AHC125)	1		6	
t_{PHZ} , t_{PLZ}	\overline{OE}	Y	$C_L = 15\text{ pF}$	$T_A = 25^\circ\text{C}$		4.6 ⁽¹⁾	6.8 ⁽¹⁾	ns
				$T_A = -55^\circ\text{C}$ to 125°C (SN54AHC125)	1 ⁽¹⁾		8 ⁽¹⁾	
				$T_A = -40^\circ\text{C}$ to 85°C (SN74AHC125)	1 ⁽¹⁾		8 ⁽¹⁾	
				$T_A = -40^\circ\text{C}$ to 125°C (recommended SN74AHC125)	1 ⁽¹⁾		8 ⁽¹⁾	
t_{PLH} , t_{PHL}	A	Y	$C_L = 50\text{ pF}$	$T_A = 25^\circ\text{C}$		5.3	7.5	ns
				$T_A = -55^\circ\text{C}$ to 125°C (SN54AHC125)	1		8.5	
				$T_A = -40^\circ\text{C}$ to 85°C (SN74AHC125)	1		8.5	
				$T_A = -40^\circ\text{C}$ to 125°C (recommended SN74AHC125)	1		8.5	
t_{PZH} , t_{PZL}	\overline{OE}	Y	$C_L = 50\text{ pF}$	$T_A = 25^\circ\text{C}$		5.1	7.1	ns
				$T_A = -55^\circ\text{C}$ to 125°C (SN54AHC125)	1		8	
				$T_A = -40^\circ\text{C}$ to 85°C (SN74AHC125)	1		8	
				$T_A = -40^\circ\text{C}$ to 125°C (recommended SN74AHC125)	1		8	
t_{PHZ} , t_{PLZ}	\overline{OE}	Y	$C_L = 50\text{ pF}$	$T_A = 25^\circ\text{C}$		6.1	8.8	ns
				$T_A = -55^\circ\text{C}$ to 125°C (SN54AHC125)	1		10	
				$T_A = -40^\circ\text{C}$ to 85°C (SN74AHC125)	1		10	
				$T_A = -40^\circ\text{C}$ to 125°C (recommended SN74AHC125)	1		10	
$t_{sk(o)}$	\overline{OE}	Y	$C_L = 50\text{ pF}$	$T_A = 25^\circ\text{C}$			1 ⁽²⁾	ns
				$T_A = -40^\circ\text{C}$ to 85°C (SN74AHC125)			1	

5.8 Noise Characteristics

$V_{CC} = 5\text{ V}$, $C_L = 50\text{ pF}$, and $T_A = 25^\circ\text{C}$ ⁽¹⁾

PARAMETER		MIN	MAX	UNIT
$V_{OL(P)}$	Quiet output, maximum dynamic (V_{OL})		0.8	V
$V_{OL(V)}$	Quiet output, minimum dynamic (V_{OL})		-0.8	V
$V_{OH(V)}$	Quiet output, minimum dynamic (V_{OH})	4.4		V
$V_{IH(D)}$	High-level dynamic input voltage	3.5		V
$V_{IL(D)}$	Low-level dynamic input voltage		1.5	V

(1) Characteristics are for surface-mount packages only.

5.9 Operating Characteristics

$V_{CC} = 5\text{ V}$ and $T_A = 25^\circ\text{C}$

PARAMETER	TEST CONDITIONS	TYP	UNIT
C_{pd}	No load and $f = 1\text{ MHz}$	9.5	pF

5.10 Typical Characteristics

Figure 5-1 shows I_{CC} for varying V_{IN} values when V_{CC} is $5\text{ V} \pm 0.5\text{ V}$ and $T_A = 25^\circ\text{C}$.

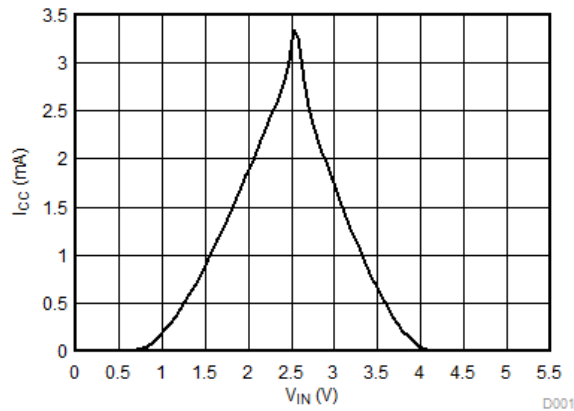
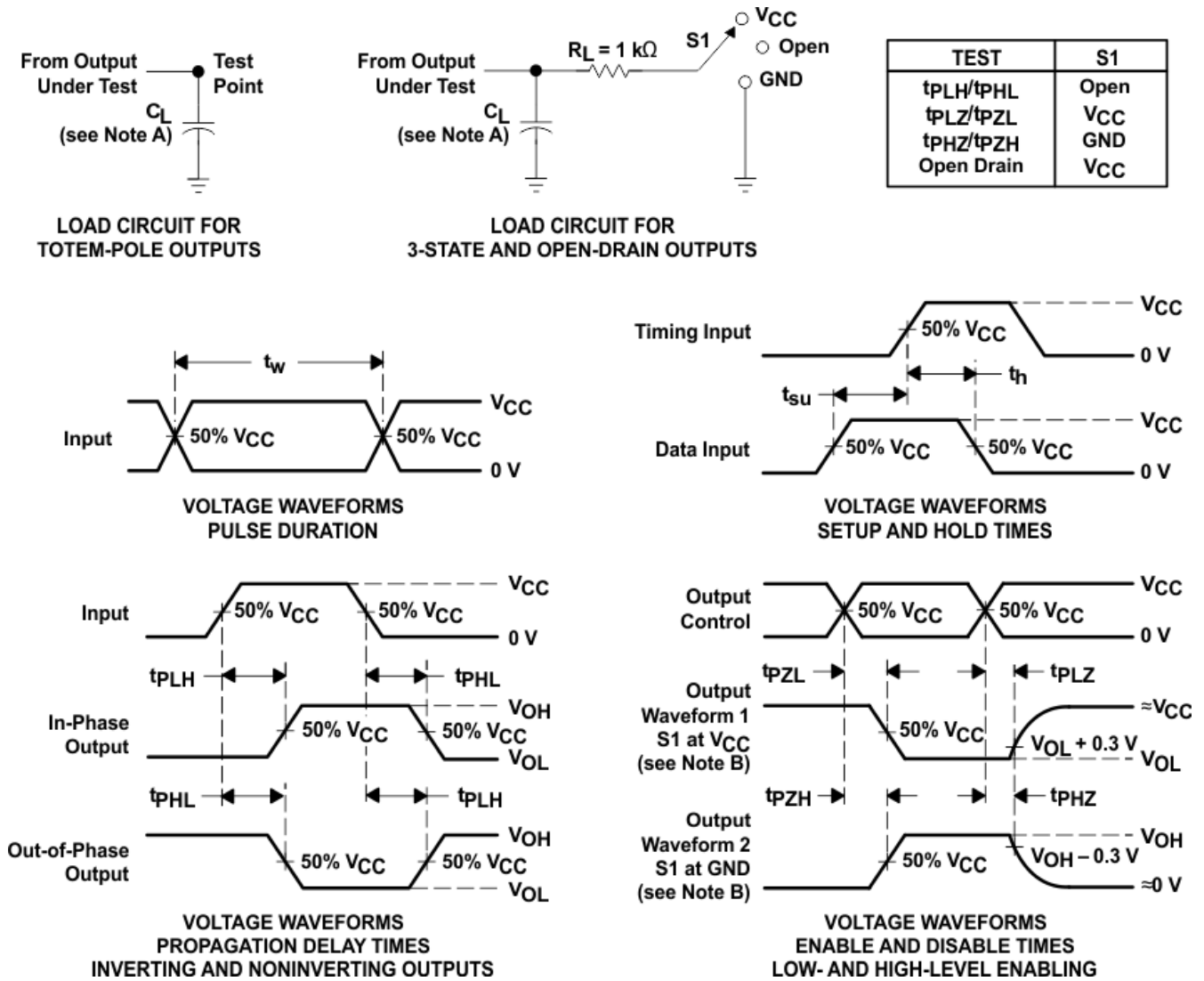

Figure 5-1. V_{IN} vs I_{CC}

6 Parameter Measurement Information



- A. C_L includes probe and jig capacitance.
- B. Waveform 1 is for an output with internal conditions such that the output is low except when disabled by the output control. Waveform 2 is for an output with internal conditions such that the output is high except when disabled by the output control.
- C. All input pulses are supplied by generators having the following characteristics: PRR $\leq 1\text{ MHz}$, $Z_O = 50\ \Omega$, $t_r \leq 3\text{ ns}$, $t_f \leq 3\text{ ns}$.
- D. The outputs are measured one at a time with one input transition per measurement.
- E. All parameters and waveforms are not applicable to all devices.

Figure 6-1. Load Circuit and Voltage Waveforms

7 Detailed Description

7.1 Overview

The SNx4AHC125 devices have four integrated bus buffer gates. Each gate can be individually controlled from their respective output enable pins or tied together and controlled simultaneously. This allows for control of up to four different lines from one device. Often times a microcontroller have multiple function options for a single pin. By using GPIO pins to enable specific buffers, the SNx4AHC125 can act as a multiplexer to select a specific data line depending on what pin function is selected on the microcontroller. At the same time, the lines that are not selected are isolated from the pin.

7.2 Functional Block Diagram

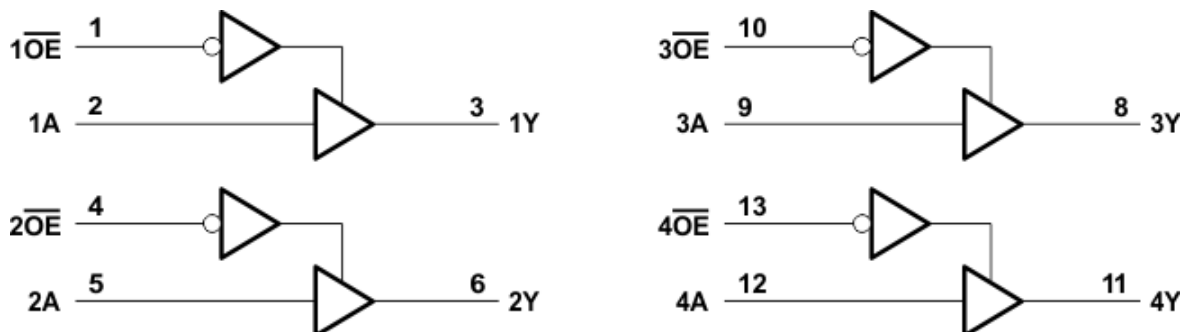

Pin numbers shown are for the D, DB, DGV, J, N, NS, PW, RGY, and W packages.

7.3 Feature Description

Each buffer has its own output enable. This allows for control of each buffer individually. When the output enable is LOW, the input is passed to the output. When the output enable is HIGH, the output is high impedance. This feature is useful in applications that might require isolation.

7.4 Device Functional Modes

Table 7-1 lists the functional modes of the SNx4AHC125.

**Table 7-1. Function Table
(Each Buffer)**

INPUTS		OUTPUT
\overline{OE}	A	Y
L	H	H
L	L	L
H	X	Z

8 Application and Implementation

Note

Information in the following applications sections is not part of the TI component specification, and TI does not warrant its accuracy or completeness. TI's customers are responsible for determining suitability of components for their purposes, as well as validating and testing their design implementation to confirm system functionality.

8.1 Application Information

The wide operating range of the SNx4AHC125 devices allows for implementation into a variety of applications. In addition to the wide operating range, these devices differentiate from similar devices because they have four buffers that can be individually controlled through their independent output enable (\overline{OE}) pins. Each buffer is either enabled and passes data from A to Y, or disabled and set to a high-impedance state.

8.2 Typical Application

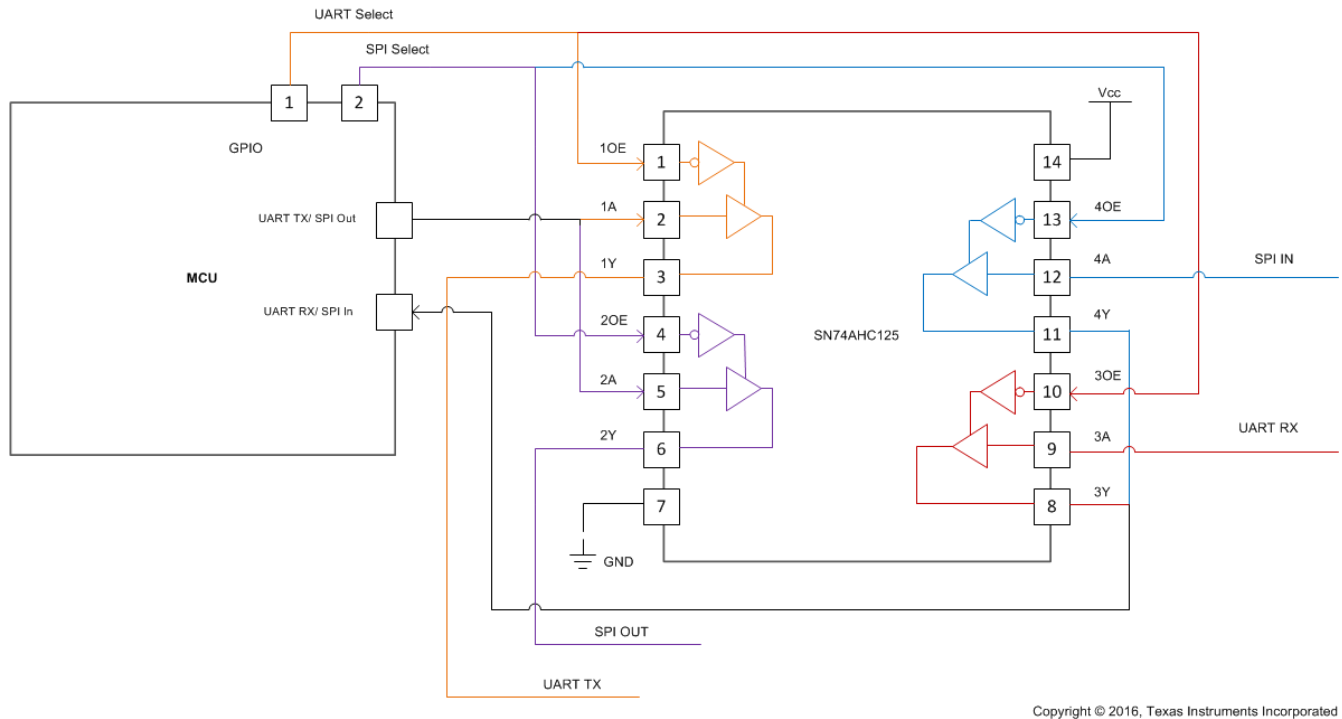

Copyright © 2016, Texas Instruments Incorporated

Figure 8-1. Digital MUX

8.2.1 Design Requirements

It is best to set V_{CC} for the SN74AHC125 to the same level as the microcontroller logic levels. This allows for optimal performance. The SN74AHC125 can safely handle input levels from -0.5 V to 7 V. However, if the logic levels that are being received vary from the V_{CC} level of the device then errors can occur. For example, if V_{CC} is 5.5 V then the minimum high-level input voltage (V_{IH}) level is 3.85 V. This means if the microcontroller is sending a HIGH signal, but HIGH = 3.3 V, it would be too low a level for the SNx4AHC125 to register it as what it must be. In this case V_{CC} would need to be lowered in order to lower the V_{IH} minimum. The opposite is also true for low-level input voltage (V_{IL}). If V_{CC} is set to 2 V, then V_{IL} maximum is 0.5 V. Depending on the microcontroller logic levels, a LOW signal may not go low enough for the SNx4AHC125 to register it.

8.2.2 Detailed Design Procedure

1. Recommended Input Conditions:

- For V_{IH} and V_{IL} levels at varying V_{CC} , see [Recommended Operating Conditions](#).
- Be mindful of rise time and fall time specifications for the output enable pins to ensure that the right buffers are enabled and the others are disabled in time. This minimizes interference on the microcontroller pin and to exterior circuitry. See [Switching Characteristics, \$V_{CC} = 3.3\text{ V} \pm 0.3\text{ V}\$](#) and [Switching Characteristics, \$V_{CC} = 5\text{ V} \pm 0.5\text{ V}\$](#) table for more details.

2. Recommended Output Conditions:

- Load currents must not exceed I_O maximum per output and must not exceed continuous current through V_{CC} or GND total current for the part. These limits are located in the [Absolute Maximum Ratings](#).
- Outputs must not be pulled above V_{CC} .

8.2.3 Application Curves

Typical device at 25°C

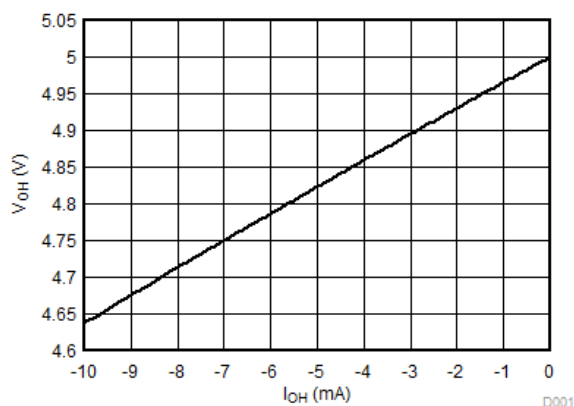

Figure 8-2. I_{OH} vs V_{OH}

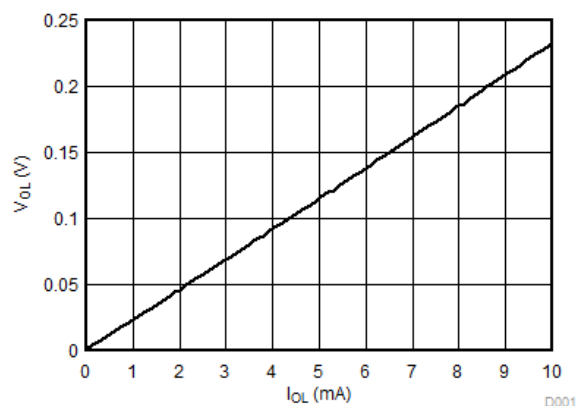

Figure 8-3. I_{OL} vs V_{OL}

8.3 Power Supply Recommendations

The power supply can be any voltage between the minimum and maximum supply voltage rating located in the [Recommended Operating Conditions](#).

Each V_{CC} pin must have a good bypass capacitor to prevent power disturbance. For devices with a single supply, a 0.1- μF capacitor is recommended and if there are multiple V_{CC} pins then a 0.01- μF or 0.022- μF capacitor is recommended for each power pin. It is ok to parallel multiple bypass capacitors to reject different frequencies of noise. 0.1- μF and 1- μF capacitors are commonly used in parallel. The bypass capacitor must be installed as close to the power pin as possible for best results.

8.4 Layout

8.4.1 Layout Guidelines

When using multiple bit logic devices, inputs must not ever float. In many cases, functions or parts of functions of digital logic devices are unused; for example, when only two inputs of a triple-input AND gate are used or only 3 of the 4 buffer gates are used. Such input pins must not be left unconnected because the undefined voltages at the outside connections result in undefined operational states. Specified below are the rules that must be observed under all circumstances. All unused inputs of digital logic devices must be connected to a high or low bias to prevent them from floating. The logic level that must be applied to any particular unused input depends on the function of the device. Generally, they are tied to GND or V_{CC} (whichever make more sense or is more convenient).

8.4.1.1 Layout Example

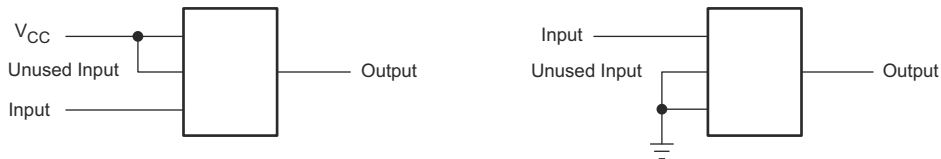

Figure 8-4. Layout Diagram

9 Device and Documentation Support

9.1 Documentation Support (Analog)

9.1.1 Related Documentation

For related documentation see the following:

[Implications of Slow or Floating CMOS Inputs](#) (SCBA004)

9.1.2 Related Links

The table below lists quick access links. Categories include technical documents, support and community resources, tools and software, and quick access to sample or buy.

Table 9-1. Related Links

PARTS	PRODUCT FOLDER	SAMPLE & BUY	TECHNICAL DOCUMENTS	TOOLS & SOFTWARE	SUPPORT & COMMUNITY
SN54AHC125	Click here	Click here	Click here	Click here	Click here
SN74AHC125	Click here	Click here	Click here	Click here	Click here

9.2 Receiving Notification of Documentation Updates

To receive notification of documentation updates, navigate to the device product folder on [ti.com](#). Click on *Notifications* to register and receive a weekly digest of any product information that has changed. For change details, review the revision history included in any revised document.

9.3 Support Resources

[TI E2E™ support forums](#) are an engineer's go-to source for fast, verified answers and design help — straight from the experts. Search existing answers or ask your own question to get the quick design help you need.

Linked content is provided "AS IS" by the respective contributors. They do not constitute TI specifications and do not necessarily reflect TI's views; see TI's [Terms of Use](#).

9.4 Trademarks

TI E2E™ is a trademark of Texas Instruments.

All trademarks are the property of their respective owners.

9.5 Electrostatic Discharge Caution



This integrated circuit can be damaged by ESD. Texas Instruments recommends that all integrated circuits be handled with appropriate precautions. Failure to observe proper handling and installation procedures can cause damage.

ESD damage can range from subtle performance degradation to complete device failure. Precision integrated circuits may be more susceptible to damage because very small parametric changes could cause the device not to meet its published specifications.

9.6 Glossary

[TI Glossary](#)

This glossary lists and explains terms, acronyms, and definitions.

10 Revision History

NOTE: Page numbers for previous revisions may differ from page numbers in the current version.

Changes from Revision N (October 2023) to Revision O (February 2024)

Page

- Updated thermal values for RGY package from RθJA = 55.1 to 87.1, RθJC(top) = 52.3 to 92.6, RθJB = 49.4 to 30.9, ΨJT = 14.6 to 2.4, ΨJB = 31 to 61.7, RθJC(bot) = 12.7 to 45.1, all values in °C/W **6**

Changes from Revision M (June 2023) to Revision N (October 2023)	Page
• Updated D and PW packages for RθJC(top), RθJB, ΨJT, ΨJB, and RθJC(bot), all values in °C/W	6

11 Mechanical, Packaging, and Orderable Information

The following pages include mechanical, packaging, and orderable information. This information is the most current data available for the designated devices. This data is subject to change without notice and revision of this document. For browser-based versions of this data sheet, refer to the left-hand navigation.

PACKAGING INFORMATION

Orderable part number	Status (1)	Material type (2)	Package Pins	Package qty Carrier	RoHS (3)	Lead finish/ Ball material (4)	MSL rating/ Peak reflow (5)	Op temp (°C)	Part marking (6)
5962-9686801Q2A	Active	Production	LCCC (FK) 20	55 TUBE	No	SNPB	N/A for Pkg Type	-55 to 125	5962- 9686801Q2A SNJ54AHC 125FK
5962-9686801QCA	Active	Production	CDIP (J) 14	25 TUBE	No	SNPB	N/A for Pkg Type	-55 to 125	5962-9686801QC A SNJ54AHC125J
5962-9686801QDA	Active	Production	CFP (W) 14	25 TUBE	No	SNPB	N/A for Pkg Type	-55 to 125	5962-9686801QD A SNJ54AHC125W
SN74AHC125BQAR	Active	Production	WQFN (BQA) 14	3000 LARGE T&R	Yes	SN	Level-1-260C-UNLIM	-40 to 125	AHC125
SN74AHC125BQAR.A	Active	Production	WQFN (BQA) 14	3000 LARGE T&R	Yes	SN	Level-1-260C-UNLIM	-40 to 125	AHC125
SN74AHC125D	Obsolete	Production	SOIC (D) 14	-	-	Call TI	Call TI	-40 to 125	AHC125
SN74AHC125DBR	NRND	Production	SSOP (DB) 14	2000 LARGE T&R	Yes	NIPDAU	Level-1-260C-UNLIM	-40 to 125	HA125
SN74AHC125DBR.A	NRND	Production	SSOP (DB) 14	2000 LARGE T&R	Yes	NIPDAU	Level-1-260C-UNLIM	-40 to 125	HA125
SN74AHC125DGVR	NRND	Production	TVSOP (DGV) 14	2000 LARGE T&R	Yes	NIPDAU	Level-1-260C-UNLIM	-40 to 125	HA125
SN74AHC125DGVR.A	NRND	Production	TVSOP (DGV) 14	2000 LARGE T&R	Yes	NIPDAU	Level-1-260C-UNLIM	-40 to 125	HA125
SN74AHC125DR	Active	Production	SOIC (D) 14	2500 LARGE T&R	Yes	NIPDAU	Level-1-260C-UNLIM	-40 to 125	AHC125
SN74AHC125DR.A	Active	Production	SOIC (D) 14	2500 LARGE T&R	Yes	NIPDAU	Level-1-260C-UNLIM	-40 to 125	AHC125
SN74AHC125N	Active	Production	PDIP (N) 14	25 TUBE	Yes	NIPDAU	N/A for Pkg Type	-40 to 125	SN74AHC125N
SN74AHC125N.A	Active	Production	PDIP (N) 14	25 TUBE	Yes	NIPDAU	N/A for Pkg Type	-40 to 125	SN74AHC125N
SN74AHC125NE4	Active	Production	PDIP (N) 14	25 TUBE	Yes	NIPDAU	N/A for Pkg Type	-40 to 125	SN74AHC125N
SN74AHC125NSR	Active	Production	SOP (NS) 14	2000 LARGE T&R	Yes	NIPDAU	Level-1-260C-UNLIM	-40 to 125	AHC125
SN74AHC125NSR.A	Active	Production	SOP (NS) 14	2000 LARGE T&R	Yes	NIPDAU	Level-1-260C-UNLIM	-40 to 125	AHC125
SN74AHC125PWR	Active	Production	TSSOP (PW) 14	2000 LARGE T&R	Yes	NIPDAU SN	Level-1-260C-UNLIM	-40 to 125	HA125
SN74AHC125PWR.A	Active	Production	TSSOP (PW) 14	2000 LARGE T&R	Yes	NIPDAU	Level-1-260C-UNLIM	-40 to 125	HA125
SN74AHC125RGRYR	Active	Production	VQFN (RGY) 14	3000 LARGE T&R	Yes	NIPDAU	Level-1-260C-UNLIM	-40 to 125	HA125
SN74AHC125RGRYR.A	Active	Production	VQFN (RGY) 14	3000 LARGE T&R	Yes	NIPDAU	Level-1-260C-UNLIM	-40 to 125	HA125
SN74AHC125RGRYG4	Active	Production	VQFN (RGY) 14	3000 LARGE T&R	Yes	NIPDAU	Level-1-260C-UNLIM	-40 to 125	HA125
SN74AHC125RGRYG4.A	Active	Production	VQFN (RGY) 14	3000 LARGE T&R	Yes	NIPDAU	Level-1-260C-UNLIM	-40 to 125	HA125

Orderable part number	Status (1)	Material type (2)	Package Pins	Package qty Carrier	RoHS (3)	Lead finish/ Ball material (4)	MSL rating/ Peak reflow (5)	Op temp (°C)	Part marking (6)
SNJ54AHC125FK	Active	Production	LCCC (FK) 20	55 TUBE	No	SNPB	N/A for Pkg Type	-55 to 125	5962-9686801Q2A SNJ54AHC 125FK
SNJ54AHC125FK.A	Active	Production	LCCC (FK) 20	55 TUBE	No	SNPB	N/A for Pkg Type	-55 to 125	5962-9686801Q2A SNJ54AHC 125FK
SNJ54AHC125J	Active	Production	CDIP (J) 14	25 TUBE	No	SNPB	N/A for Pkg Type	-55 to 125	5962-9686801QC A SNJ54AHC125J
SNJ54AHC125J.A	Active	Production	CDIP (J) 14	25 TUBE	No	SNPB	N/A for Pkg Type	-55 to 125	5962-9686801QC A SNJ54AHC125J
SNJ54AHC125W	Active	Production	CFP (W) 14	25 TUBE	No	SNPB	N/A for Pkg Type	-55 to 125	5962-9686801QD A SNJ54AHC125W
SNJ54AHC125W.A	Active	Production	CFP (W) 14	25 TUBE	No	SNPB	N/A for Pkg Type	-55 to 125	5962-9686801QD A SNJ54AHC125W

⁽¹⁾ **Status:** For more details on status, see our [product life cycle](#).

⁽²⁾ **Material type:** When designated, preproduction parts are prototypes/experimental devices, and are not yet approved or released for full production. Testing and final process, including without limitation quality assurance, reliability performance testing, and/or process qualification, may not yet be complete, and this item is subject to further changes or possible discontinuation. If available for ordering, purchases will be subject to an additional waiver at checkout, and are intended for early internal evaluation purposes only. These items are sold without warranties of any kind.

⁽³⁾ **RoHS values:** Yes, No, RoHS Exempt. See the [TI RoHS Statement](#) for additional information and value definition.

⁽⁴⁾ **Lead finish/Ball material:** Parts may have multiple material finish options. Finish options are separated by a vertical ruled line. Lead finish/Ball material values may wrap to two lines if the finish value exceeds the maximum column width.

⁽⁵⁾ **MSL rating/Peak reflow:** The moisture sensitivity level ratings and peak solder (reflow) temperatures. In the event that a part has multiple moisture sensitivity ratings, only the lowest level per JEDEC standards is shown. Refer to the shipping label for the actual reflow temperature that will be used to mount the part to the printed circuit board.

⁽⁶⁾ **Part marking:** There may be an additional marking, which relates to the logo, the lot trace code information, or the environmental category of the part.

Multiple part markings will be inside parentheses. Only one part marking contained in parentheses and separated by a "-" will appear on a part. If a line is indented then it is a continuation of the previous line and the two combined represent the entire part marking for that device.

Important Information and Disclaimer: The information provided on this page represents TI's knowledge and belief as of the date that it is provided. TI bases its knowledge and belief on information provided by third parties, and makes no representation or warranty as to the accuracy of such information. Efforts are underway to better integrate information from third parties. TI has taken and continues to take reasonable steps to provide representative and accurate information but may not have conducted destructive testing or chemical analysis on incoming materials and chemicals. TI and TI suppliers consider certain information to be proprietary, and thus CAS numbers and other limited information may not be available for release.

In no event shall TI's liability arising out of such information exceed the total purchase price of the TI part(s) at issue in this document sold by TI to Customer on an annual basis.

OTHER QUALIFIED VERSIONS OF SN54AHC125, SN74AHC125 :

- Catalog : [SN74AHC125](#)

- Automotive : [SN74AHC125-Q1](#), [SN74AHC125-Q1](#)

- Enhanced Product : [SN74AHC125-EP](#), [SN74AHC125-EP](#)

- Military : [SN54AHC125](#)

NOTE: Qualified Version Definitions:

- Catalog - TI's standard catalog product

- Automotive - Q100 devices qualified for high-reliability automotive applications targeting zero defects

- Enhanced Product - Supports Defense, Aerospace and Medical Applications

- Military - QML certified for Military and Defense Applications

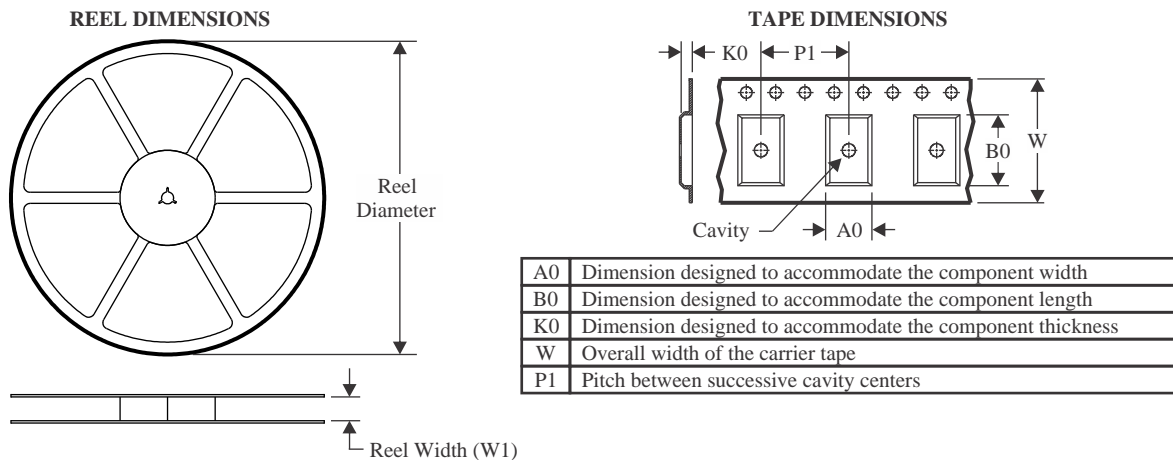
TAPE AND REEL INFORMATION

QUADRANT ASSIGNMENTS FOR PIN 1 ORIENTATION IN TAPE

*All dimensions are nominal

Device	Package Type	Package Drawing	Pins	SPQ	Reel Diameter (mm)	Reel Width W1 (mm)	A0 (mm)	B0 (mm)	K0 (mm)	P1 (mm)	W (mm)	Pin1 Quadrant
SN74AHC125BQAR	WQFN	BQA	14	3000	180.0	12.4	2.8	3.3	1.1	4.0	12.0	Q1
SN74AHC125DBR	SSOP	DB	14	2000	330.0	16.4	8.35	6.6	2.4	12.0	16.0	Q1
SN74AHC125DGVR	TVSOP	DGV	14	2000	330.0	12.4	6.8	4.0	1.6	8.0	12.0	Q1
SN74AHC125DR	SOIC	D	14	2500	330.0	16.4	6.5	9.0	2.1	8.0	16.0	Q1
SN74AHC125DR	SOIC	D	14	2500	330.0	12.4	3.75	3.75	1.15	8.0	12.0	Q1
SN74AHC125NSR	SOP	NS	14	2000	330.0	16.4	8.1	10.4	2.5	12.0	16.0	Q1
SN74AHC125PWR	TSSOP	PW	14	2000	330.0	12.4	6.9	5.6	1.6	8.0	12.0	Q1
SN74AHC125RGYR	VQFN	RGY	14	3000	330.0	12.4	3.75	3.75	1.15	8.0	12.0	Q1
SN74AHC125RGYRG4	VQFN	RGY	14	3000	330.0	12.4	3.75	3.75	1.15	8.0	12.0	Q1

TAPE AND REEL BOX DIMENSIONS

*All dimensions are nominal

Device	Package Type	Package Drawing	Pins	SPQ	Length (mm)	Width (mm)	Height (mm)
SN74AHC125BQAR	WQFN	BQA	14	3000	210.0	185.0	35.0
SN74AHC125DBR	SSOP	DB	14	2000	353.0	353.0	32.0
SN74AHC125DGVR	TVSOP	DGV	14	2000	353.0	353.0	32.0
SN74AHC125DR	SOIC	D	14	2500	353.0	353.0	32.0
SN74AHC125DR	SOIC	D	14	2500	340.5	336.1	32.0
SN74AHC125NSR	SOP	NS	14	2000	353.0	353.0	32.0
SN74AHC125PWR	TSSOP	PW	14	2000	353.0	353.0	32.0
SN74AHC125RGYR	VQFN	RGY	14	3000	360.0	360.0	36.0
SN74AHC125RGYRG4	VQFN	RGY	14	3000	360.0	360.0	36.0

TUBE

*All dimensions are nominal

Device	Package Name	Package Type	Pins	SPQ	L (mm)	W (mm)	T (μm)	B (mm)
5962-9686801Q2A	FK	LCCC	20	55	506.98	12.06	2030	NA
5962-9686801QDA	W	CFP	14	25	506.98	26.16	6220	NA
SN74AHC125N	N	PDIP	14	25	506	13.97	11230	4.32
SN74AHC125N	N	PDIP	14	25	506	13.97	11230	4.32
SN74AHC125N.A	N	PDIP	14	25	506	13.97	11230	4.32
SN74AHC125N.A	N	PDIP	14	25	506	13.97	11230	4.32
SN74AHC125NE4	N	PDIP	14	25	506	13.97	11230	4.32
SN74AHC125NE4	N	PDIP	14	25	506	13.97	11230	4.32
SNJ54AHC125FK	FK	LCCC	20	55	506.98	12.06	2030	NA
SNJ54AHC125FK.A	FK	LCCC	20	55	506.98	12.06	2030	NA
SNJ54AHC125W	W	CFP	14	25	506.98	26.16	6220	NA
SNJ54AHC125W.A	W	CFP	14	25	506.98	26.16	6220	NA

GENERIC PACKAGE VIEW

RGY 14

VQFN - 1 mm max height

3.5 x 3.5, 0.5 mm pitch

PLASTIC QUAD FLATPACK - NO LEAD

This image is a representation of the package family, actual package may vary.
Refer to the product data sheet for package details.

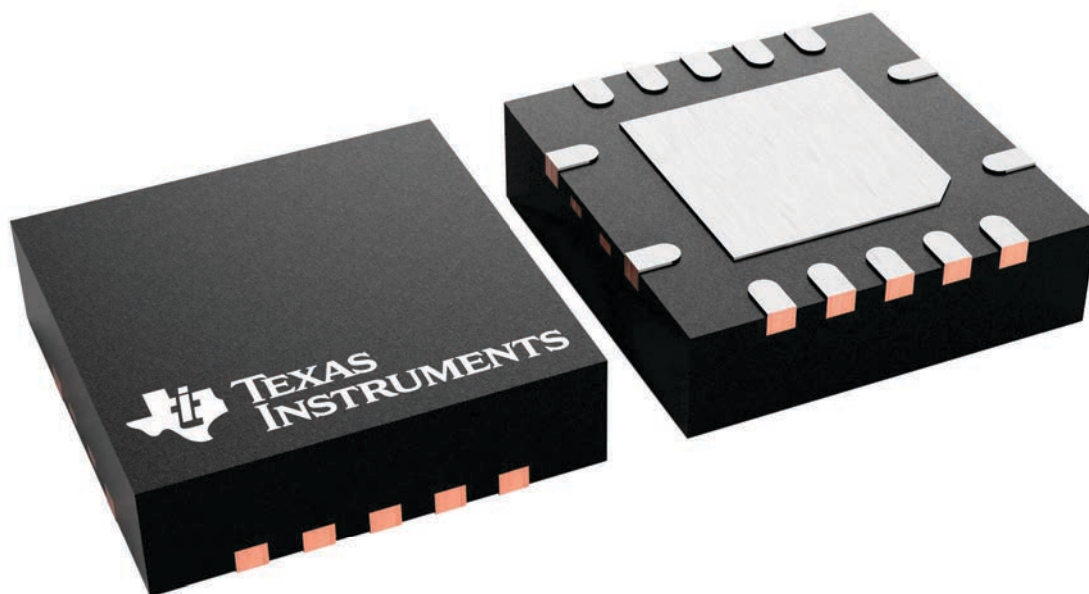

4231541/A

RGY0014A

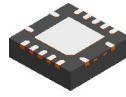

PACKAGE OUTLINE

VQFN - 1 mm max height

PLASTIC QUAD FLATPACK - NO LEAD

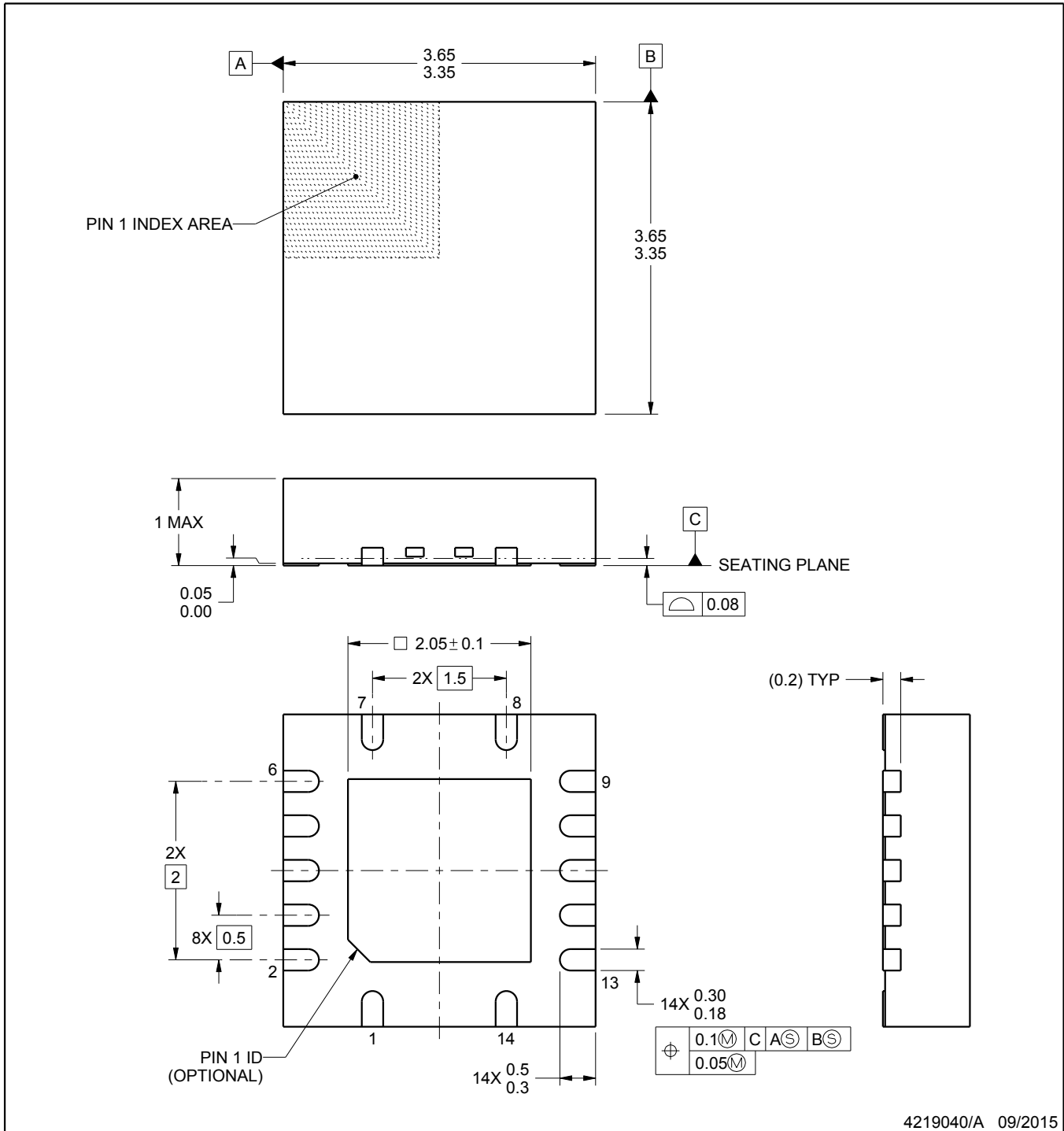

4219040/A 09/2015

NOTES:

1. All linear dimensions are in millimeters. Any dimensions in parenthesis are for reference only. Dimensioning and tolerancing per ASME Y14.5M.
2. This drawing is subject to change without notice.
3. The package thermal pad must be soldered to the printed circuit board for thermal and mechanical performance.

EXAMPLE BOARD LAYOUT

RGY0014A

VQFN - 1 mm max height

PLASTIC QUAD FLATPACK - NO LEAD

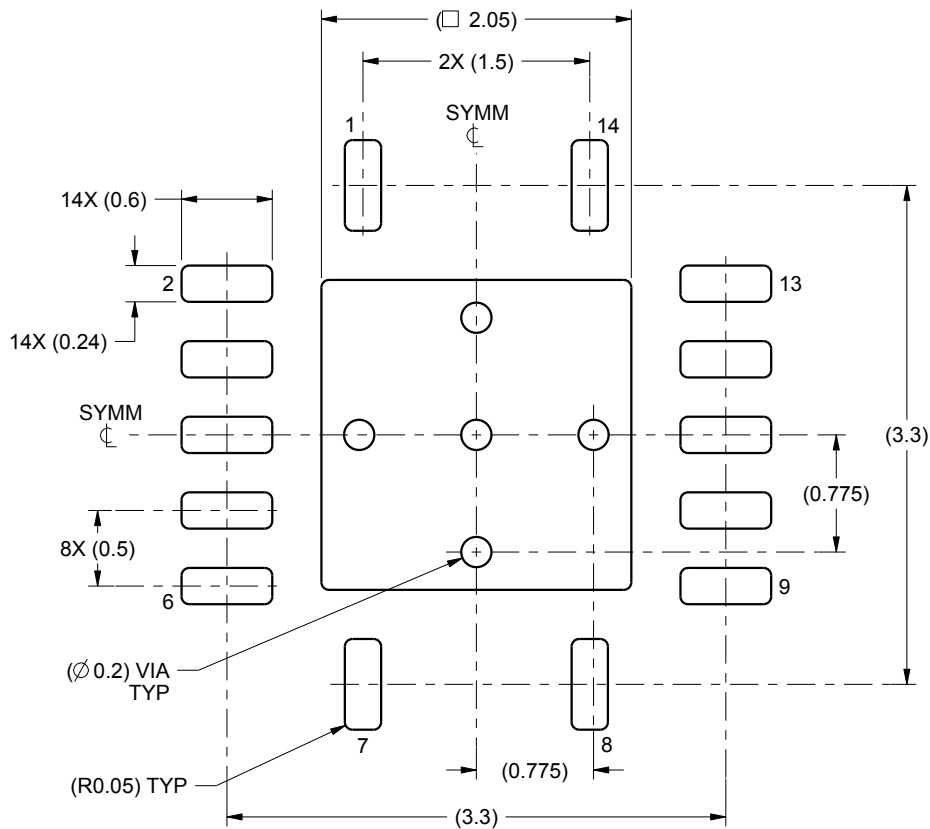

LAND PATTERN EXAMPLE
SCALE:20X

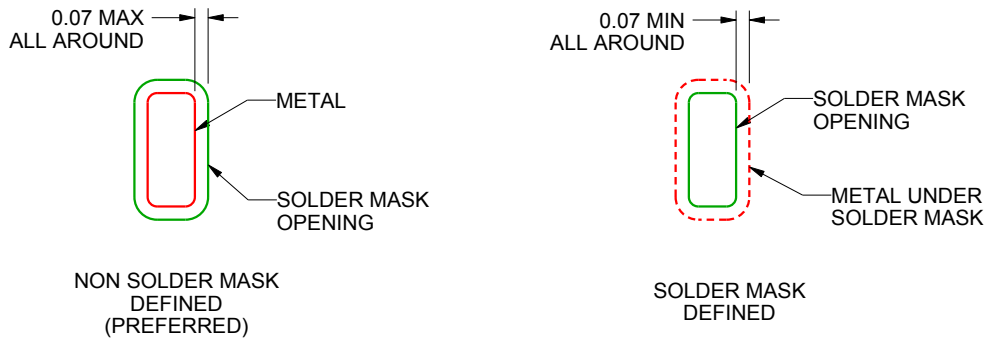

SOLDER MASK DETAILS

4219040/A 09/2015

NOTES: (continued)

4. This package is designed to be soldered to a thermal pad on the board. For more information, see Texas Instruments literature number SLUA271 (www.ti.com/lit/slua271).

EXAMPLE STENCIL DESIGN

RGY0014A

VQFN - 1 mm max height

PLASTIC QUAD FLATPACK - NO LEAD

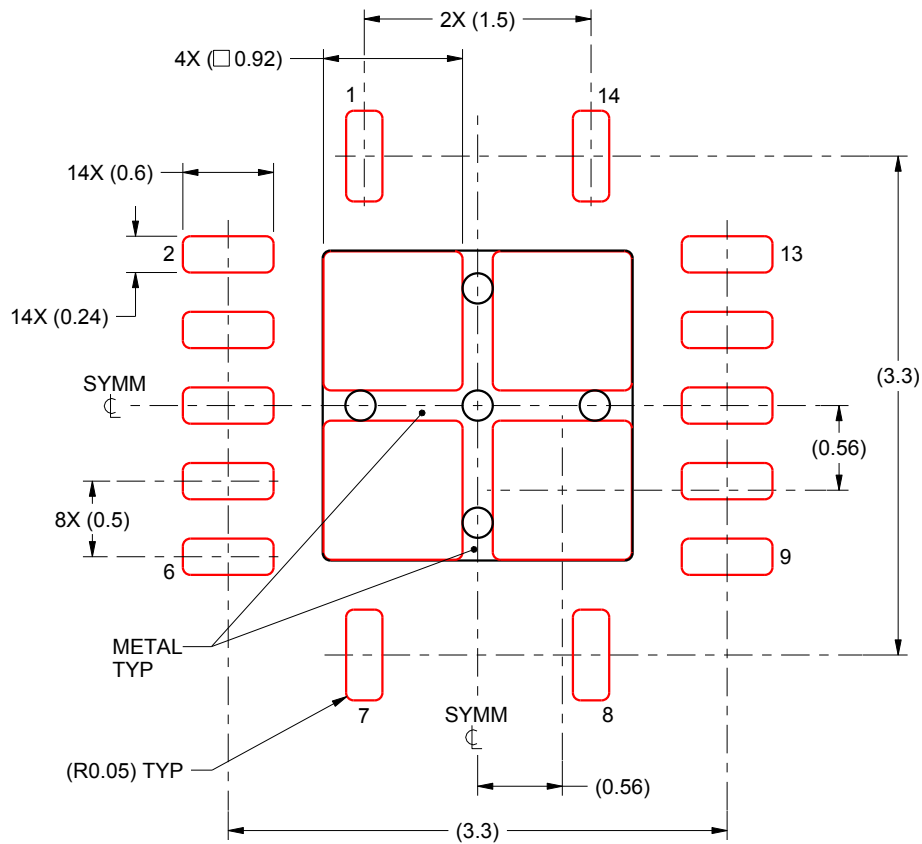

SOLDER PASTE EXAMPLE
BASED ON 0.125 mm THICK STENCIL

EXPOSED PAD
80% PRINTED SOLDER COVERAGE BY AREA
SCALE:20X

4219040/A 09/2015

NOTES: (continued)

5. Laser cutting apertures with trapezoidal walls and rounded corners may offer better paste release. IPC-7525 may have alternate design recommendations.



D0014A

PACKAGE OUTLINE

SOIC - 1.75 mm max height

SMALL OUTLINE INTEGRATED CIRCUIT



4220718/A 09/2016

NOTES:

1. All linear dimensions are in millimeters. Dimensions in parenthesis are for reference only. Dimensioning and tolerancing per ASME Y14.5M.
2. This drawing is subject to change without notice.
3. This dimension does not include mold flash, protrusions, or gate burrs. Mold flash, protrusions, or gate burrs shall not exceed 0.15 mm, per side.
4. This dimension does not include interlead flash. Interlead flash shall not exceed 0.43 mm, per side.
5. Reference JEDEC registration MS-012, variation AB.

EXAMPLE BOARD LAYOUT

D0014A

SOIC - 1.75 mm max height

SMALL OUTLINE INTEGRATED CIRCUIT



LAND PATTERN EXAMPLE
SCALE:8X



SOLDER MASK DETAILS

4220718/A 09/2016

NOTES: (continued)

- 6. Publication IPC-7351 may have alternate designs.
- 7. Solder mask tolerances between and around signal pads can vary based on board fabrication site.

EXAMPLE STENCIL DESIGN

D0014A

SOIC - 1.75 mm max height

SMALL OUTLINE INTEGRATED CIRCUIT



SOLDER PASTE EXAMPLE
BASED ON 0.125 mm THICK STENCIL
SCALE:8X

4220718/A 09/2016

NOTES: (continued)

8. Laser cutting apertures with trapezoidal walls and rounded corners may offer better paste release. IPC-7525 may have alternate design recommendations.
9. Board assembly site may have different recommendations for stencil design.

GENERIC PACKAGE VIEW

BQA 14

WQFN - 0.8 mm max height

2.5 x 3, 0.5 mm pitch

PLASTIC QUAD FLATPACK - NO LEAD

This image is a representation of the package family, actual package may vary.
Refer to the product data sheet for package details.

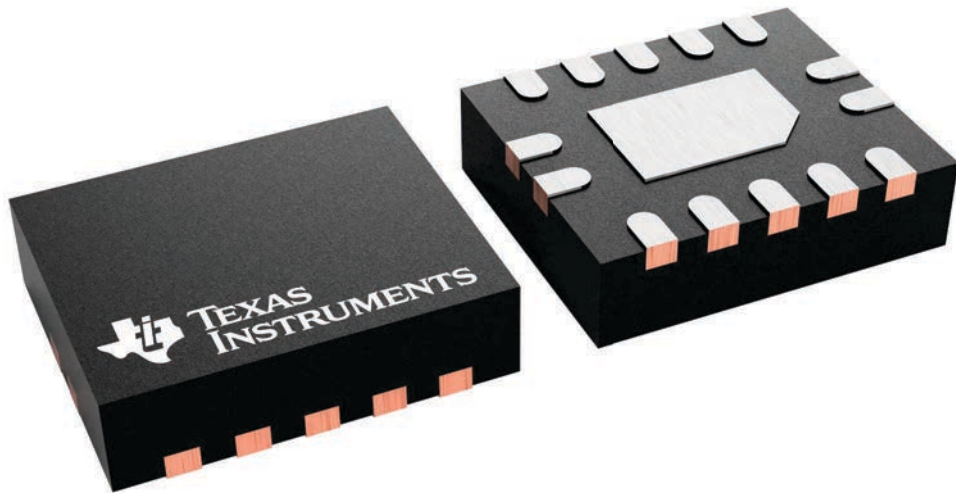

4227145/A

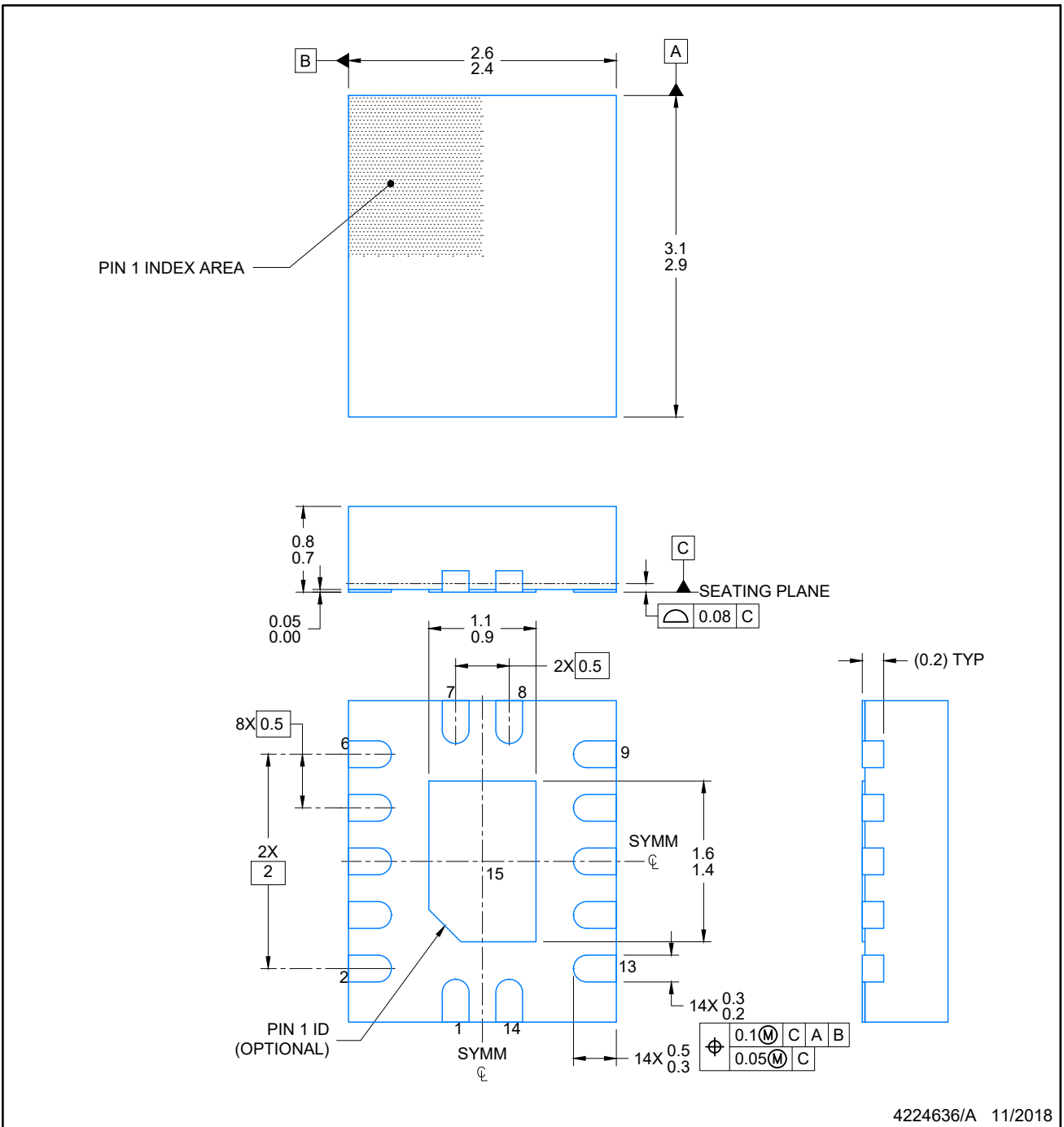

4224636/A 11/2018

NOTES:

1. All linear dimensions are in millimeters. Any dimensions in parenthesis are for reference only. Dimensioning and tolerancing per ASME Y14.5M.
2. This drawing is subject to change without notice.
3. The package thermal pad must be soldered to the printed circuit board for optimal thermal and mechanical performance.

EXAMPLE BOARD LAYOUT

WQFN - 0.8 mm max height

BQA0014A

PLASTIC QUAD FLAT PACK-NO LEAD



LAND PATTERN EXAMPLE
EXPOSED METAL SHOWN
SCALE: 20X

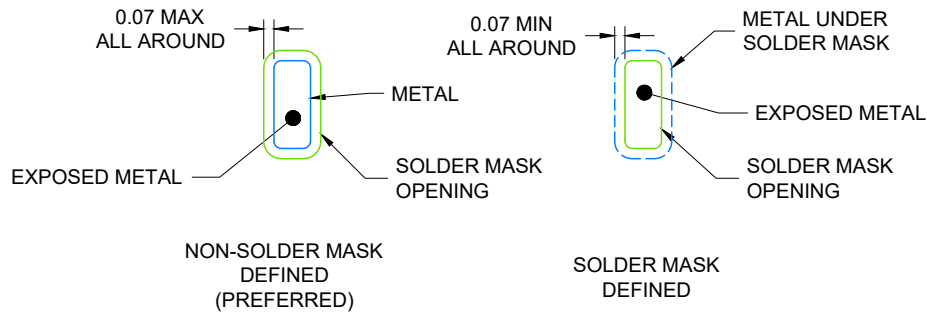

4224636/A 11/2018

NOTES: (continued)

4. This package is designed to be soldered to a thermal pad on the board. For more information, see Texas Instruments literature number SLUA271 (www.ti.com/lit/slua271).
5. Vias are optional depending on application, refer to device data sheet. If any vias are implemented, refer to their locations shown on this view. It is recommended that vias under paste be filled, plugged or tented.

EXAMPLE STENCIL DESIGN

BQA0014A

WQFN - 0.8 mm max height

PLASTIC QUAD FLAT PACK-NO LEAD



SOLDER PASTE EXAMPLE
 BASED ON 0.125 mm THICK STENCIL

EXPOSED PAD
 88% PRINTED COVERAGE BY AREA
 SCALE: 20X

4224636/A 11/2018

NOTES: (continued)

- 6. Laser cutting apertures with trapezoidal walls and rounded corners may offer better paste release. IPC-7525 may have alternate design recommendations.

MECHANICAL DATA

NS (R-PDSO-G**)

PLASTIC SMALL-OUTLINE PACKAGE

14-PINS SHOWN

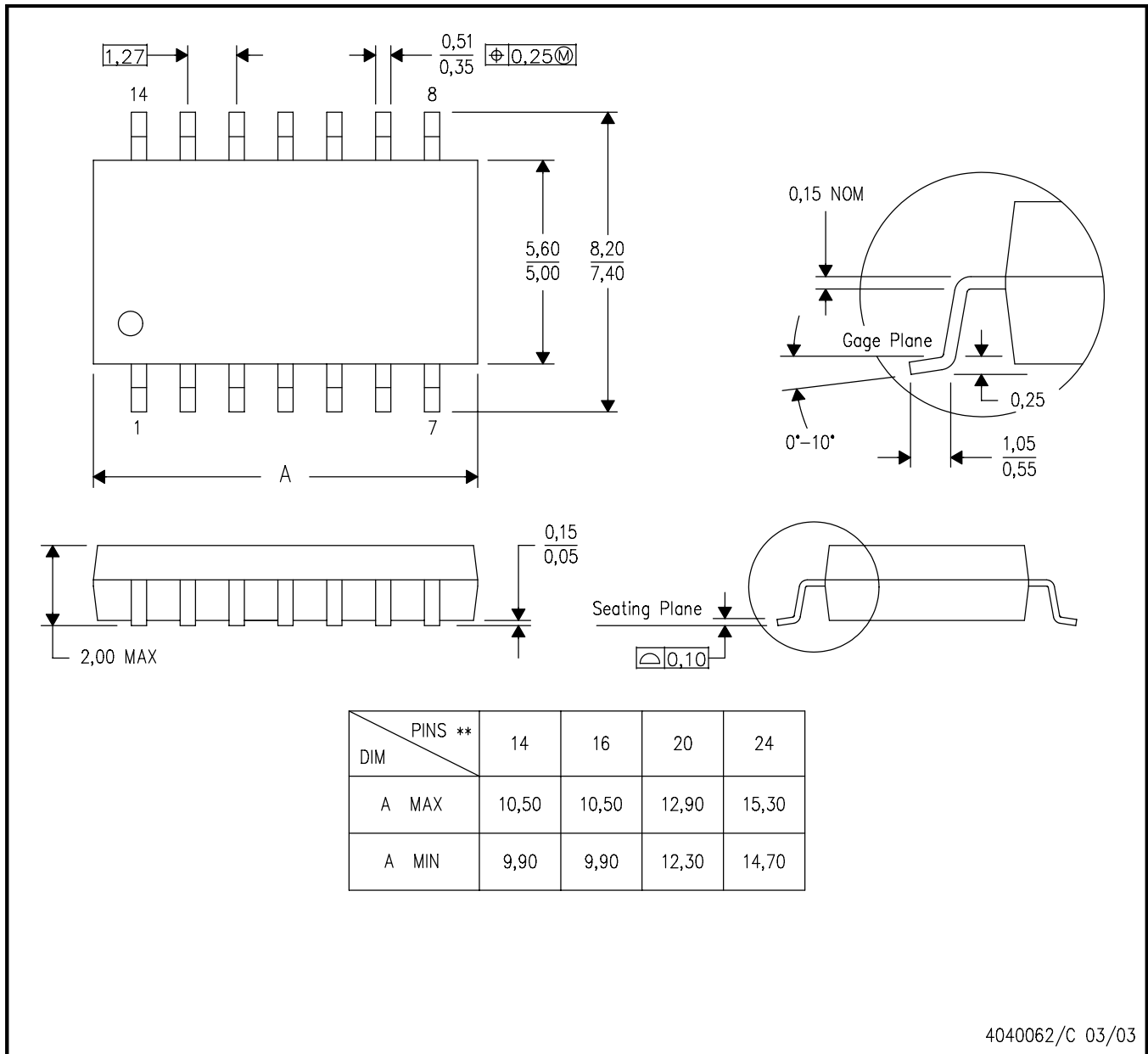

- NOTES:
- A. All linear dimensions are in millimeters.
 - B. This drawing is subject to change without notice.
 - C. Body dimensions do not include mold flash or protrusion, not to exceed 0,15.

W (R-GDFP-F14)

CERAMIC DUAL FLATPACK

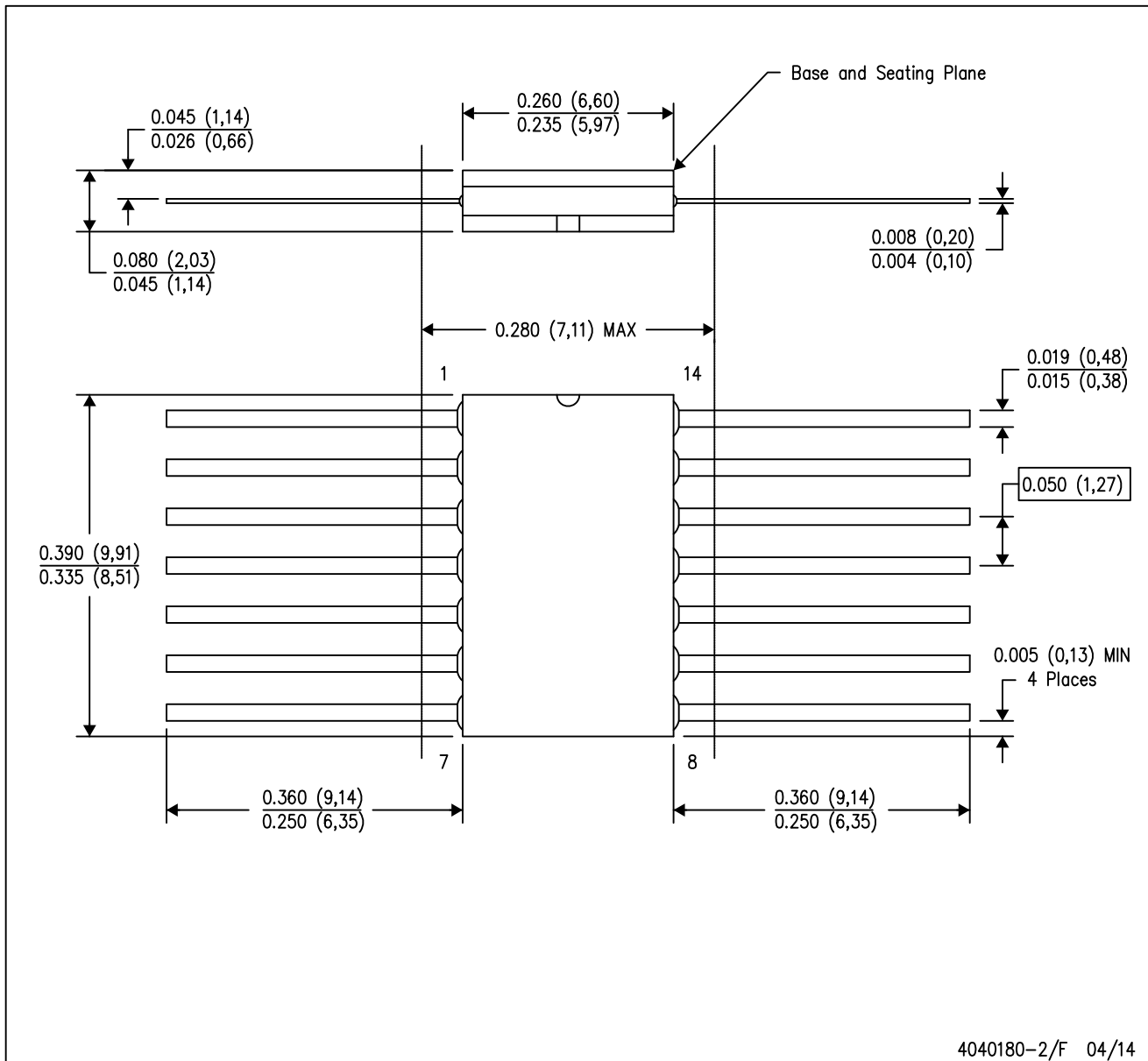

- NOTES:
- A. All linear dimensions are in inches (millimeters).
 - B. This drawing is subject to change without notice.
 - C. This package can be hermetically sealed with a ceramic lid using glass frit.
 - D. Index point is provided on cap for terminal identification only.
 - E. Falls within MIL STD 1835 GDFP1-F14

DGV (R-PDSO-G**)

PLASTIC SMALL-OUTLINE

24 PINS SHOWN

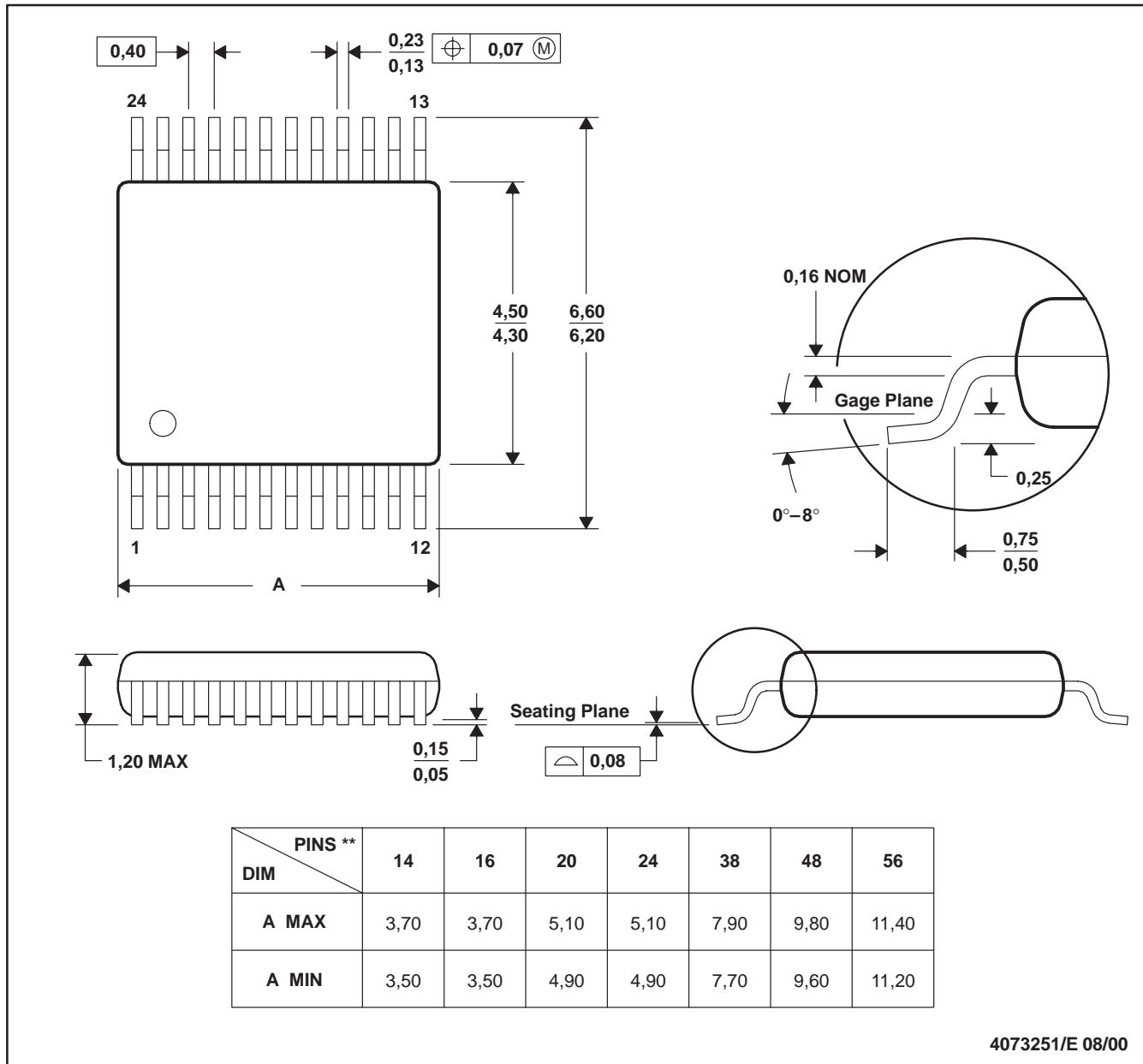

- NOTES: A. All linear dimensions are in millimeters.
 B. This drawing is subject to change without notice.
 C. Body dimensions do not include mold flash or protrusion, not to exceed 0,15 per side.
 D. Falls within JEDEC: 24/48 Pins – MO-153
 14/16/20/56 Pins – MO-194

DB0014A



PACKAGE OUTLINE

SSOP - 2 mm max height

SMALL OUTLINE PACKAGE

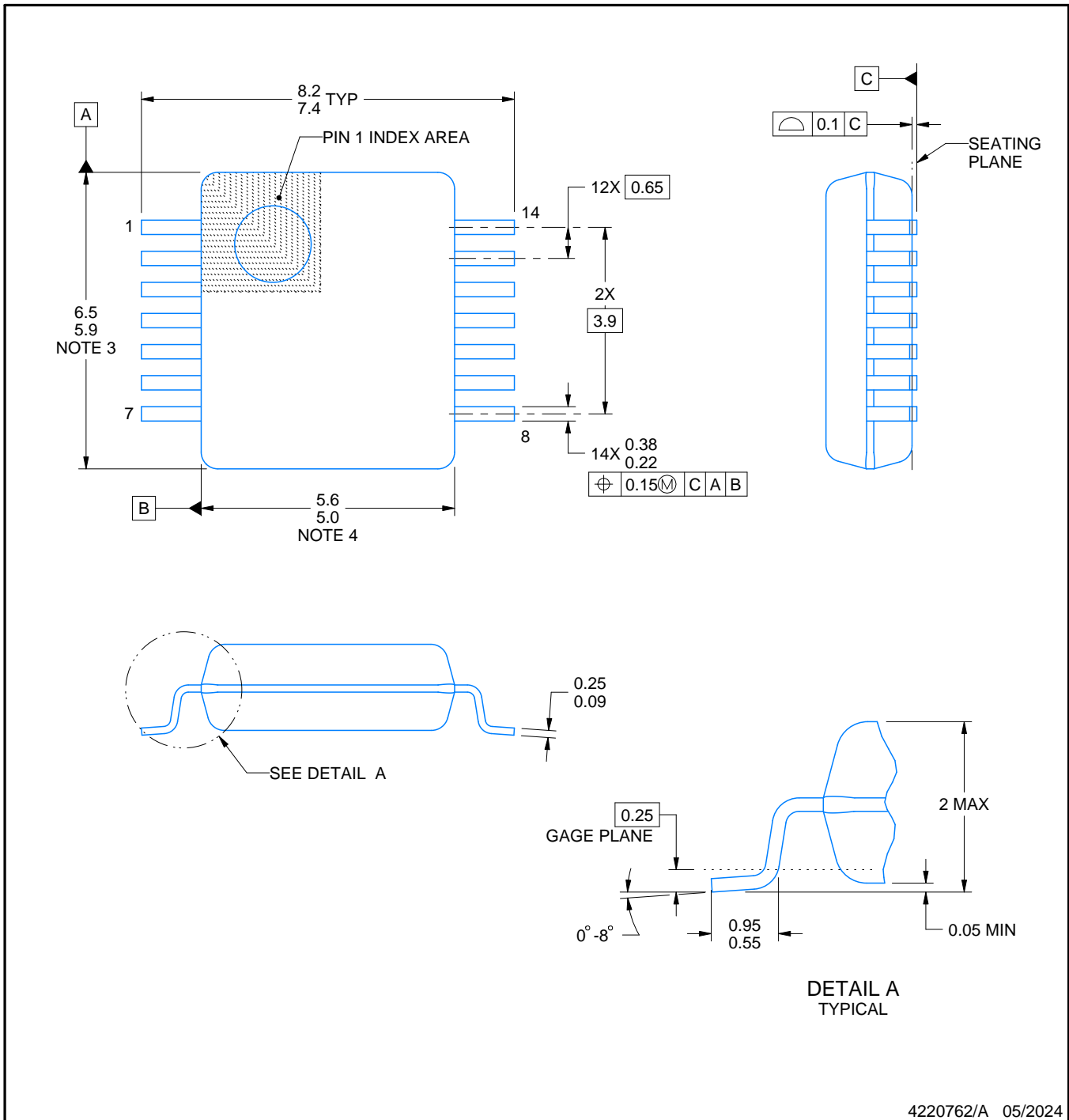

NOTES:

1. All linear dimensions are in millimeters. Any dimensions in parenthesis are for reference only. Dimensioning and tolerancing per ASME Y14.5M.
2. This drawing is subject to change without notice.
3. This dimension does not include mold flash, protrusions, or gate burrs. Mold flash, protrusions, or gate burrs shall not exceed 0.15 mm per side.
4. Reference JEDEC registration MO-150.

EXAMPLE BOARD LAYOUT

DB0014A

SSOP - 2 mm max height

SMALL OUTLINE PACKAGE

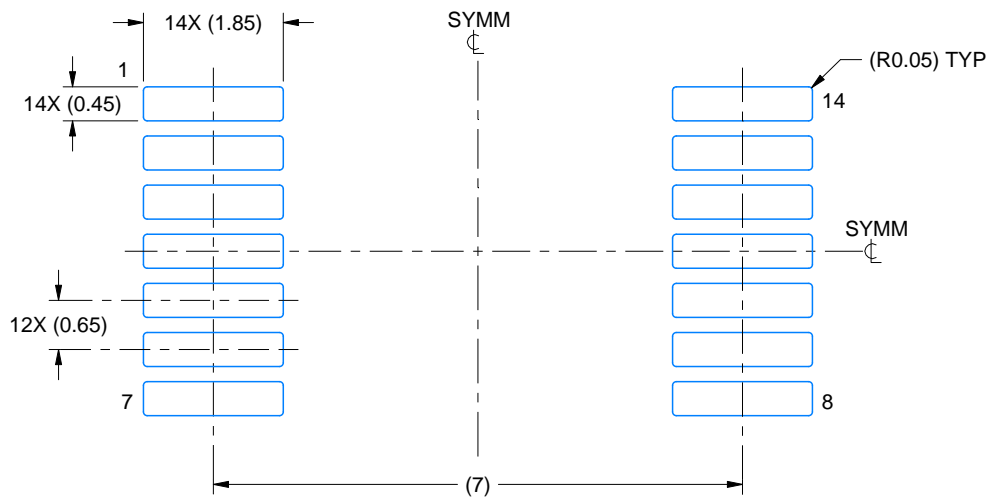

LAND PATTERN EXAMPLE
EXPOSED METAL SHOWN
SCALE: 10X

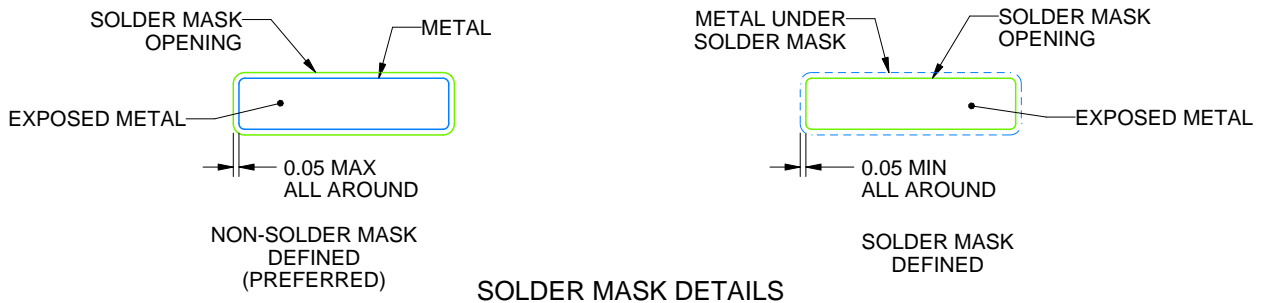

4220762/A 05/2024

NOTES: (continued)

- 5. Publication IPC-7351 may have alternate designs.
- 6. Solder mask tolerances between and around signal pads can vary based on board fabrication site.

EXAMPLE STENCIL DESIGN

DB0014A

SSOP - 2 mm max height

SMALL OUTLINE PACKAGE

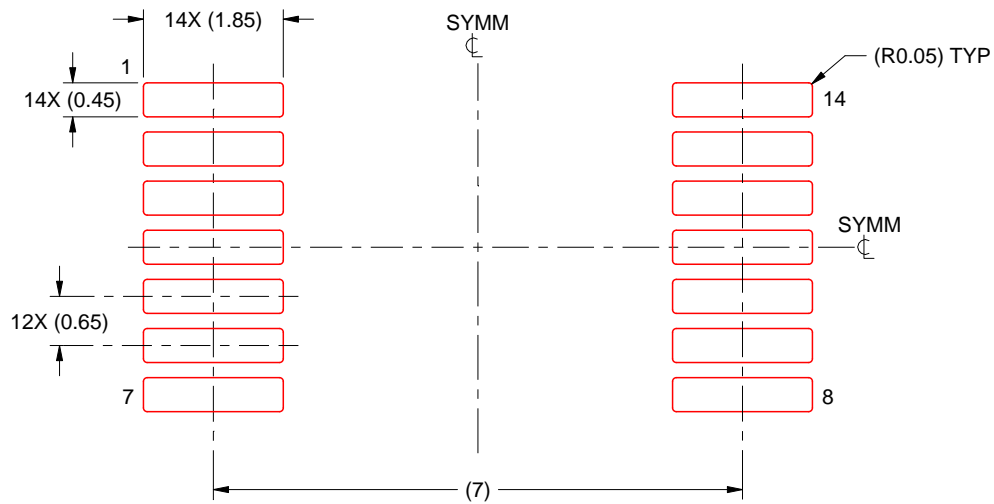

SOLDER PASTE EXAMPLE
BASED ON 0.125 mm THICK STENCIL
SCALE: 10X

4220762/A 05/2024

NOTES: (continued)

7. Laser cutting apertures with trapezoidal walls and rounded corners may offer better paste release. IPC-7525 may have alternate design recommendations.
8. Board assembly site may have different recommendations for stencil design.

GENERIC PACKAGE VIEW

FK 20

LCCC - 2.03 mm max height

8.89 x 8.89, 1.27 mm pitch

LEADLESS CERAMIC CHIP CARRIER

This image is a representation of the package family, actual package may vary.
Refer to the product data sheet for package details.



4229370VA\

J 14

GENERIC PACKAGE VIEW
CDIP - 5.08 mm max height
CERAMIC DUAL IN LINE PACKAGE



Images above are just a representation of the package family, actual package may vary.
Refer to the product data sheet for package details.

4040083-5/G

J0014A

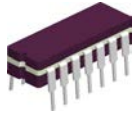

PACKAGE OUTLINE

CDIP - 5.08 mm max height

CERAMIC DUAL IN LINE PACKAGE



4214771/A 05/2017

NOTES:

1. All controlling linear dimensions are in inches. Dimensions in brackets are in millimeters. Any dimension in brackets or parenthesis are for reference only. Dimensioning and tolerancing per ASME Y14.5M.
2. This drawing is subject to change without notice.
3. This package is hermetically sealed with a ceramic lid using glass frit.
4. Index point is provided on cap for terminal identification only and on press ceramic glass frit seal only.
5. Falls within MIL-STD-1835 and GDIP1-T14.

EXAMPLE BOARD LAYOUT

J0014A

CDIP - 5.08 mm max height

CERAMIC DUAL IN LINE PACKAGE



LAND PATTERN EXAMPLE
NON-SOLDER MASK DEFINED
SCALE: 5X

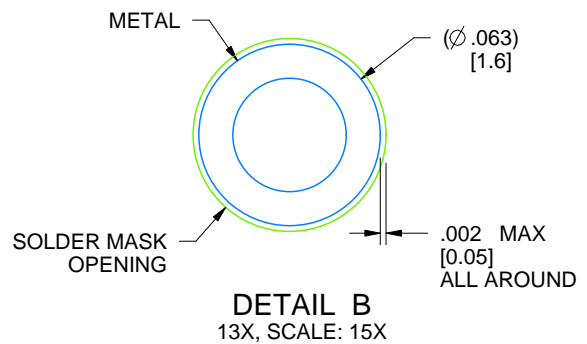

4214771/A 05/2017

N (R-PDIP-T**)

PLASTIC DUAL-IN-LINE PACKAGE

16 PINS SHOWN



4040049/E 12/2002

- NOTES:
- A. All linear dimensions are in inches (millimeters).
 - B. This drawing is subject to change without notice.
 - (C) Falls within JEDEC MS-001, except 18 and 20 pin minimum body length (Dim A).
 - (D) The 20 pin end lead shoulder width is a vendor option, either half or full width.

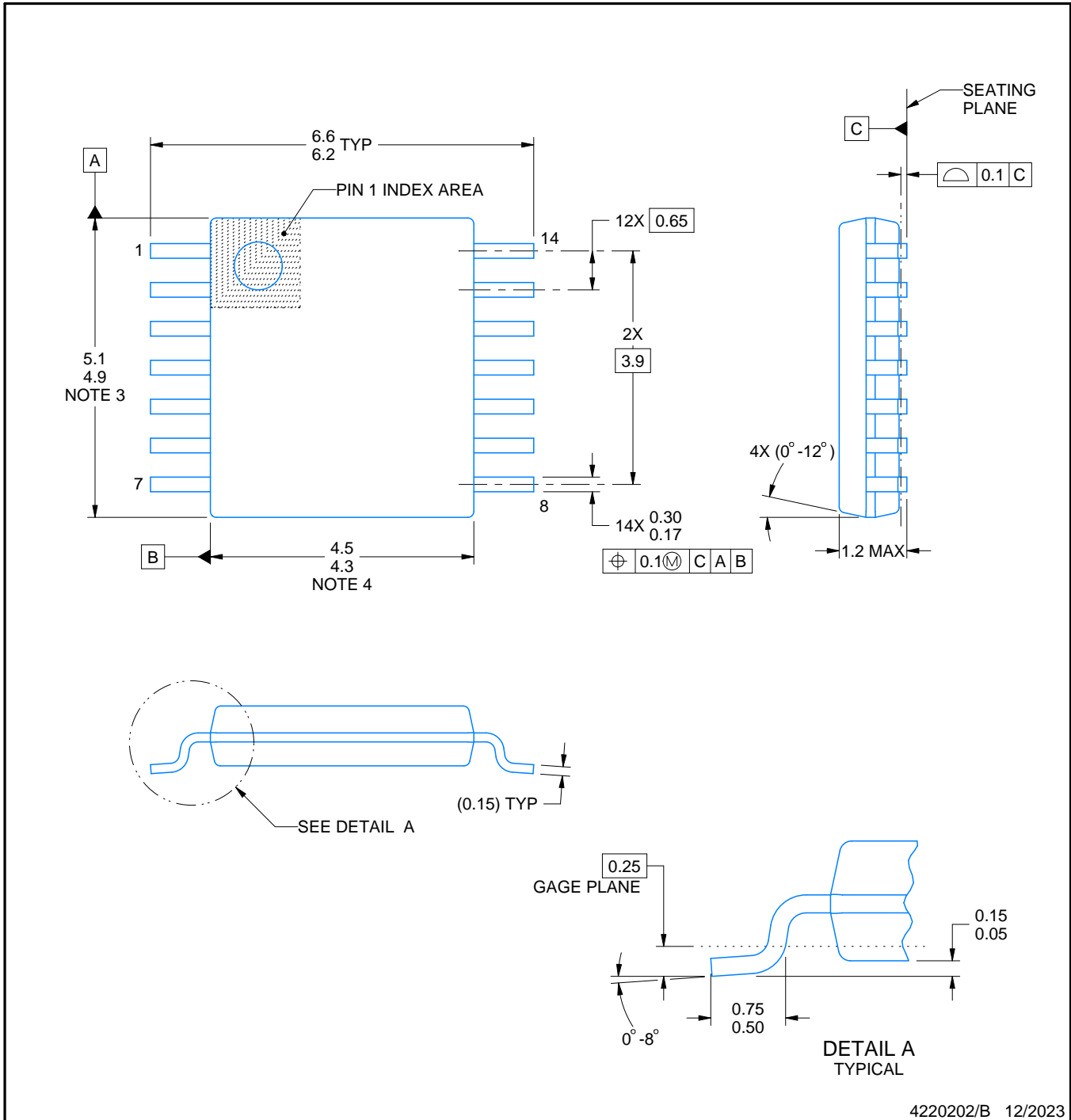

4220202/B 12/2023

NOTES:

1. All linear dimensions are in millimeters. Any dimensions in parenthesis are for reference only. Dimensioning and tolerancing per ASME Y14.5M.
2. This drawing is subject to change without notice.
3. This dimension does not include mold flash, protrusions, or gate burrs. Mold flash, protrusions, or gate burrs shall not exceed 0.15 mm per side.
4. This dimension does not include interlead flash. Interlead flash shall not exceed 0.25 mm per side.
5. Reference JEDEC registration MO-153.

EXAMPLE BOARD LAYOUT

PW0014A

TSSOP - 1.2 mm max height

SMALL OUTLINE PACKAGE



LAND PATTERN EXAMPLE
EXPOSED METAL SHOWN
SCALE: 10X



4220202/B 12/2023

NOTES: (continued)

- 6. Publication IPC-7351 may have alternate designs.
- 7. Solder mask tolerances between and around signal pads can vary based on board fabrication site.

EXAMPLE STENCIL DESIGN

PW0014A

TSSOP - 1.2 mm max height

SMALL OUTLINE PACKAGE



SOLDER PASTE EXAMPLE
BASED ON 0.125 mm THICK STENCIL
SCALE: 10X

4220202/B 12/2023

NOTES: (continued)

8. Laser cutting apertures with trapezoidal walls and rounded corners may offer better paste release. IPC-7525 may have alternate design recommendations.
9. Board assembly site may have different recommendations for stencil design.

IMPORTANT NOTICE AND DISCLAIMER

TI PROVIDES TECHNICAL AND RELIABILITY DATA (INCLUDING DATASHEETS), DESIGN RESOURCES (INCLUDING REFERENCE DESIGNS), APPLICATION OR OTHER DESIGN ADVICE, WEB TOOLS, SAFETY INFORMATION, AND OTHER RESOURCES "AS IS" AND WITH ALL FAULTS, AND DISCLAIMS ALL WARRANTIES, EXPRESS AND IMPLIED, INCLUDING WITHOUT LIMITATION ANY IMPLIED WARRANTIES OF MERCHANTABILITY, FITNESS FOR A PARTICULAR PURPOSE OR NON-INFRINGEMENT OF THIRD PARTY INTELLECTUAL PROPERTY RIGHTS.

These resources are intended for skilled developers designing with TI products. You are solely responsible for (1) selecting the appropriate TI products for your application, (2) designing, validating and testing your application, and (3) ensuring your application meets applicable standards, and any other safety, security, regulatory or other requirements.

These resources are subject to change without notice. TI grants you permission to use these resources only for development of an application that uses the TI products described in the resource. Other reproduction and display of these resources is prohibited. No license is granted to any other TI intellectual property right or to any third party intellectual property right. TI disclaims responsibility for, and you fully indemnify TI and its representatives against any claims, damages, costs, losses, and liabilities arising out of your use of these resources.

TI's products are provided subject to [TI's Terms of Sale](#), [TI's General Quality Guidelines](#), or other applicable terms available either on ti.com or provided in conjunction with such TI products. TI's provision of these resources does not expand or otherwise alter TI's applicable warranties or warranty disclaimers for TI products. Unless TI explicitly designates a product as custom or customer-specified, TI products are standard, catalog, general purpose devices.

TI objects to and rejects any additional or different terms you may propose.

Copyright © 2026, Texas Instruments Incorporated

Last updated 10/2025