

# TPS51120 Buck Controller Evaluation Module User's Guide



## Table of Contents

<b>1 Description</b> .....	2
<b>2 Electrical Performance</b> .....	2
<b>3 Schematic</b> .....	3
<b>4 Test Setup and Results</b> .....	4
4.1 Test Setup.....	4
4.2 Test Procedure.....	4
4.3 Start-Up Performance.....	5
4.4 Transient Performance.....	5
<b>5 Configuration</b> .....	6
5.1 Switching Frequency Selection.....	6
5.2 Skip Mode and Faults Disable Selection.....	6
5.3 Output Voltage Setting Selection.....	6
5.4 Control Scheme Selection.....	6
<b>6 EVM Assembly Drawing and PCB Layout</b> .....	8
<b>7 List of Materials</b> .....	11
<b>8 References</b> .....	11
<b>9 Revision History</b> .....	11

### Trademarks

D-CAP™ is a trademark of Texas Instruments.

All trademarks are the property of their respective owners.

## 1 Description

The TPS51120 is a highly sophisticated dual current mode synchronous step-down controller. It is a full-featured controller designed to run directly off three to four-cell Li-ion battery and provide high power and 5-V, 3.3-V, or both, standby regulation for all the downstream circuitry in a notebook computer system. High current, 100-mA, 5-V, or 3.3-V on-board linear regulators have glitch-free switch over function to SMPS and can be kept alive independently during standby state. The pseudo-constant frequency adaptive on-time control scheme supports full range of current mode operation including simplified loop compensation, ceramic output capacitors, and seamless transition to reduced frequency operation at light-load condition. Optional D-CAP™ mode operation optimized for SP-CAP or POSCAP output capacitors allows further reduction of external compensation parts.

The TPS51120EVM-001 evaluation module is a high efficiency, dual synchronous buck converter providing 5 V at 6 A and 3.3 V at 6 A from 8-V to 25-V input. This user's guide describes the TPS51120EVM-001 performance in D-CAP mode and  $R_{DS(on)}$  current sensing.

## 2 Electrical Performance

**Table 2-1. Electrical Performance**

Specifications		Test Conditions	MIN	TYP	MAX	Unit
Input voltage range (VBAT)			8	12	25	V
CH1	Output voltage			5		V
	Operating frequency	TONSEL: VREF2, V <sub>BAT</sub> = 12 V, I <sub>OUT1</sub> = 6 A		280		kHz
	Output current	V <sub>BAT</sub> = 8 V to 25 V		6		A
	Overcurrent limit	V <sub>BAT</sub> = 12 V		10		A
	Output ripple voltage	V <sub>BAT</sub> = 12 V, I <sub>OUT1</sub> = 6 A		40		mV <sub>p-p</sub>
CH2	Output voltage			3.3		V
	Operating frequency	TONSEL: VREF2, V <sub>BAT</sub> = 12 V, I <sub>OUT2</sub> = 6 A		430		kHz
	Output current	V <sub>BAT</sub> = 8 V to 25 V	6			A
	Overcurrent limit	V <sub>BAT</sub> = 12 V		10		A
	Output ripple voltage	V <sub>BAT</sub> = 12 V, I <sub>OUT2</sub> = 6 A		45		mV <sub>p-p</sub>

### 3 Schematic

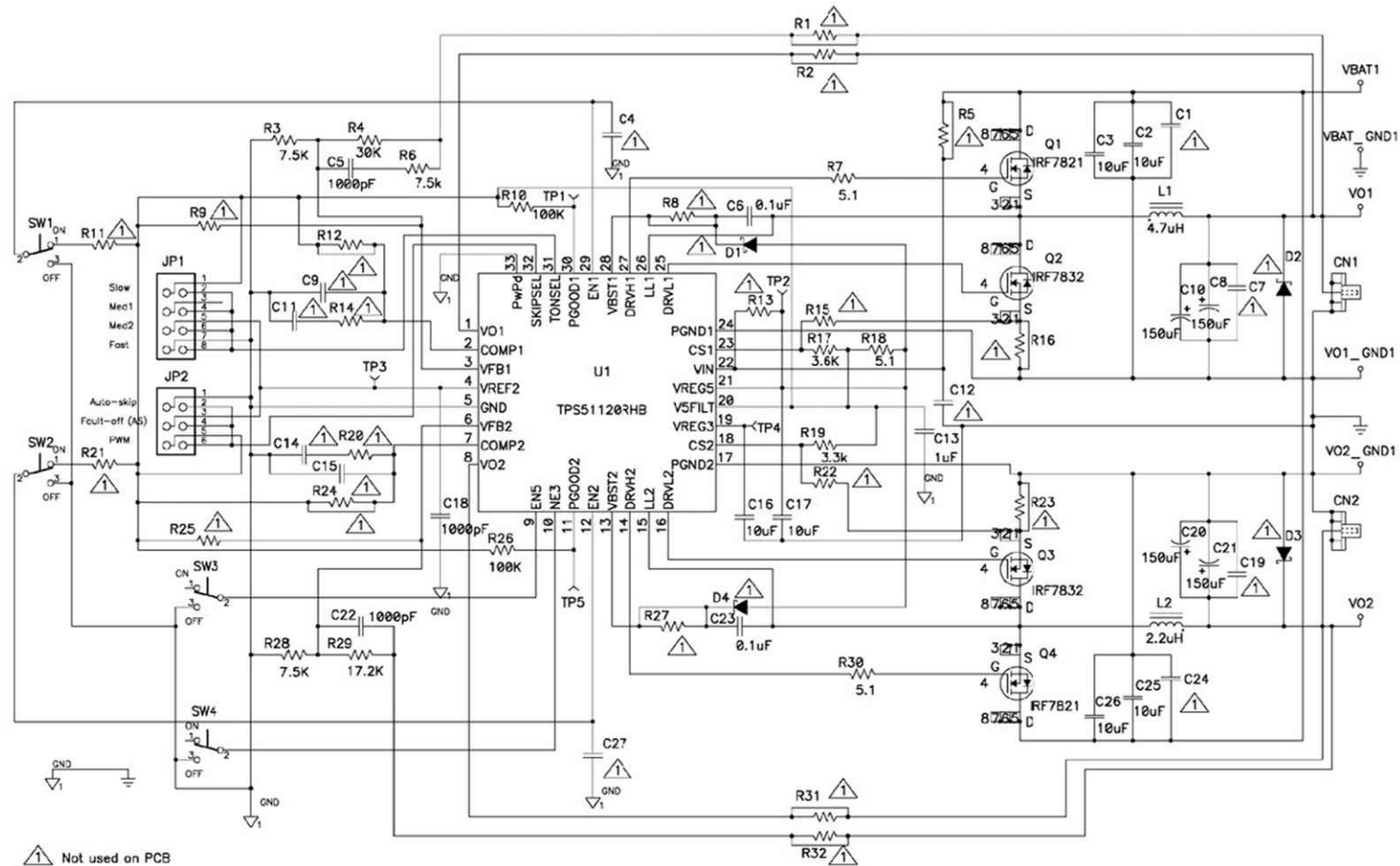

Figure 3-1. TPS51120 EVM Schematic Diagram

## 4 Test Setup and Results

### 4.1 Test Setup

Connect the test equipment and TPS51120EVM-001 board as shown in Figure 4-1.

#### 4. Test Setup and Results

##### 4.1. Test setup

Connect test equipment and TPS51120EVM-001 board as shown in Figure 2.

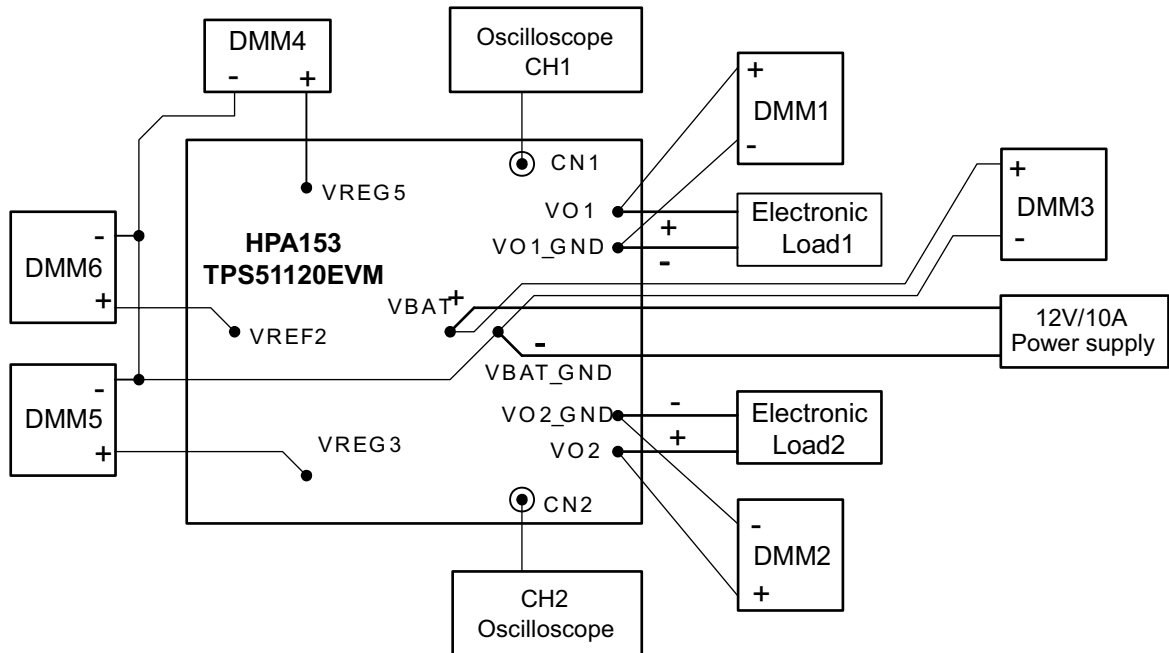

**Figure 4-1. Equipment Setup for TPS51120EVM-001 Board**

### 4.2 Test Procedure

1. Make sure the switches SW1 (EN1), SW2 (EN2), SW3 (EN5), and SW4 (EN3) are in the "OFF" position.
2. Make sure the shunt jumper for JP1 is set 5-pin to 6-pin (Med2), and shunt jumper for JP2 is set 1-pin to 2-pin (auto-skip).
3. Apply appropriate VBAT voltage to VBAT1 and VBAT\_GND1 terminals.
4. Turn on SW3 (EN5) and VREG5 (5V-LDO) starts up.
5. Turn on SW4 (EN3) and VREG3 (3.3V-LDO) starts up.
6. When SW3 and SW4 stay on, VREF2 (2V-REF) enables.
7. When SW3 and SW4 stay on and turn on SW1 (EN1), CH1-output will start up.
8. When SW3 and SW4 stay on and turn on SW2 (EN2), CH2-output will start up.

### 4.3 Start-Up Performance

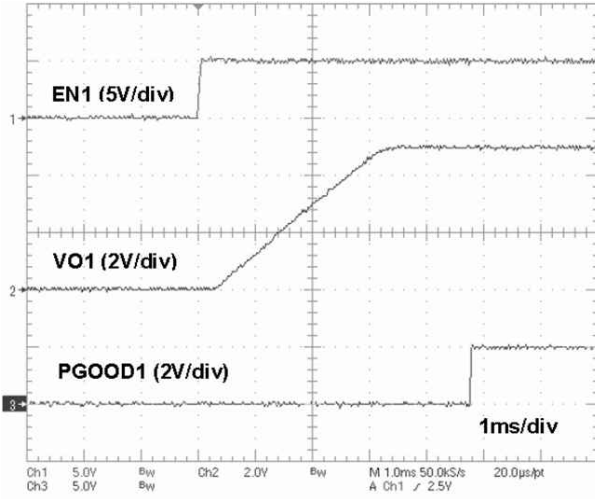

Figure 4-2. 5-V Start-Up Waveforms

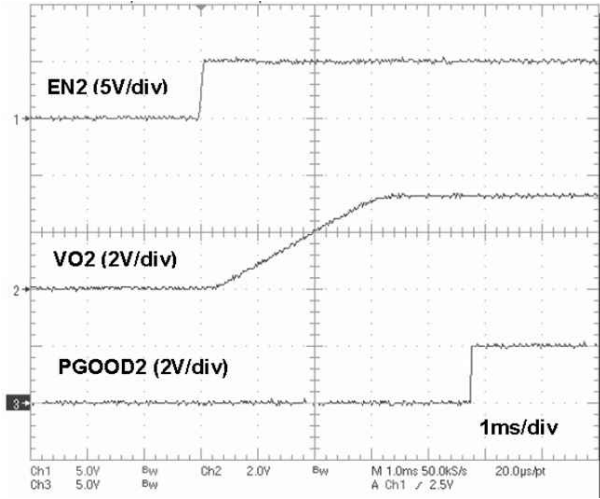

Figure 4-3. 3.3-V Start-Up Waveforms

### 4.4 Transient Performance

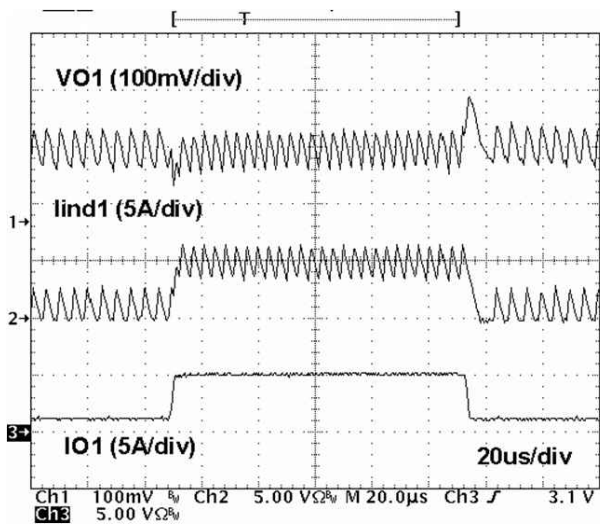

Figure 4-4. 5-V Load Transient Response

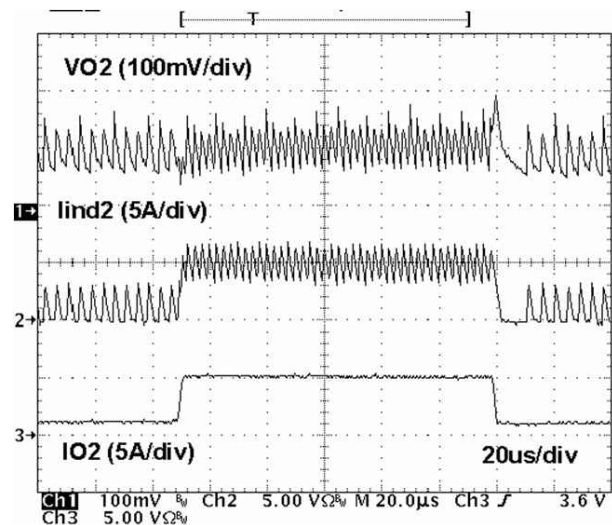

Figure 4-5. 3.3-V Load Transient Response

## 5 Configuration

This EVM could be set to the user's desirable configurations. Please refer to the following specific configuration setting sections.

### 5.1 Switching Frequency Selection

The switching frequency can be set by the TONSEL pin using JP1 on the EVM. The default setting is Medium2.

**Table 5-1. Switching Frequency Selection**

Jumper (JP1) Set to	Frequency <sup>(1)</sup>		
	TYP	CH1	CH2
Top (1-2 pin shorted)	Slow	180 kHz	270 kHz
2nd (3-4 pin shorted)	Medium1	220 kHz	330 kHz
<b>3rd (5-6 pin shorted)</b>	<b>Medium2</b>	<b>280 kHz</b>	<b>430 kHz</b>
Bottom (7-8 pin shorted)	Fast	380 kHz	580 kHz

(1) Frequencies are approximate.

### 5.2 Skip Mode and Faults Disable Selection

Skip mode can be set by the SKIPSEL pin using JP2 on the EVM. In addition, faults disable mode can be selected for debugging purpose. The default setting is auto-skip and fault enable.

**Table 5-2. Skip Mode Selection**

Jumper (JP2) set to	Skip	Faults
<b>Top (1-2 pin shorted)</b>	<b>Auto-skip</b>	<b>Enable</b>
2nd (3-4 pin shorted)	Auto-skip	Disable
Bottom (5-6 pin shorted)	PWM	Enable

### 5.3 Output Voltage Setting Selection

Output voltage can be set by the VFBx pin using some resistors on the EVM. The default setting is adjustable output.

**Table 5-3. Output Voltage Setting Selection (CH1)**

	R3	R4	R9
<b>Adjustable output</b>	7.5 kW	30 kW	Open
Fixed output; 5 V	Open	Open	0 W

**Table 5-4. Output Voltage Setting Selection (CH2)**

	R28	R29	R25
<b>Adjustable output</b>	7.5 kW	17.2 kW	Open
Fixed output; 3.3 V	Open	Open	0 W

### 5.4 Control Scheme Selection

The control scheme can be set by the COMPx pin using some resistors and capacitors on the EVM. The default setting is D-CAP mode.

**Table 5-5. Control Scheme Selection (CH1)**

	R12	C9	C11	R14
<b>D-CAP mode</b>	<b>Shorted</b>	<b>Open</b>	<b>Open</b>	<b>Open</b>
Current mode <sup>(1)</sup>	Open	Put on	Put on	Put on

(1) When current mode is selected, please add appropriate parts on C9, C11, and R14 and cut the trace between the pads of R12.

**Table 5-6. Control Scheme Selection (CH2)**

	R24	C15	C14	R20
<b>D-CAP mode</b>	<b>Shorted</b>	<b>Open</b>	<b>Open</b>	<b>Open</b>

**Table 5-6. Control Scheme Selection (CH2) (continued)**

	<b>R24</b>	<b>C15</b>	<b>C14</b>	<b>R20</b>
Current mode <sup>(1)</sup>	Open	Put on	Put on	Put on

(1) When current mode is selected, please add appropriate parts on C15, C14, and R20 and cut the trace between the pads of R24.

## 6 EVM Assembly Drawing and PCB Layout



Figure 6-1. Top Assembly

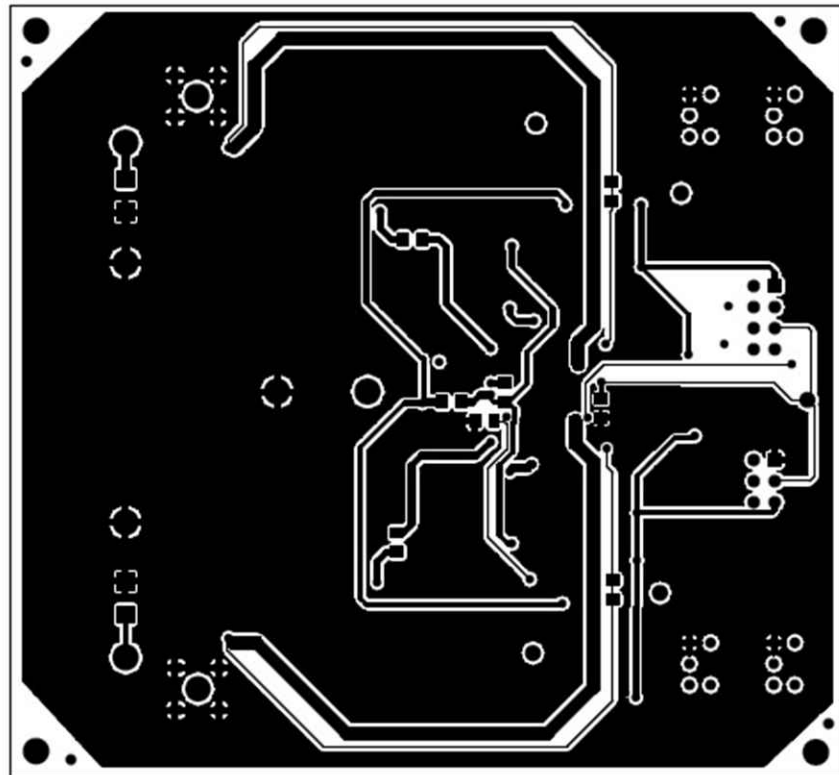

Figure 6-2. Bottom Assembly



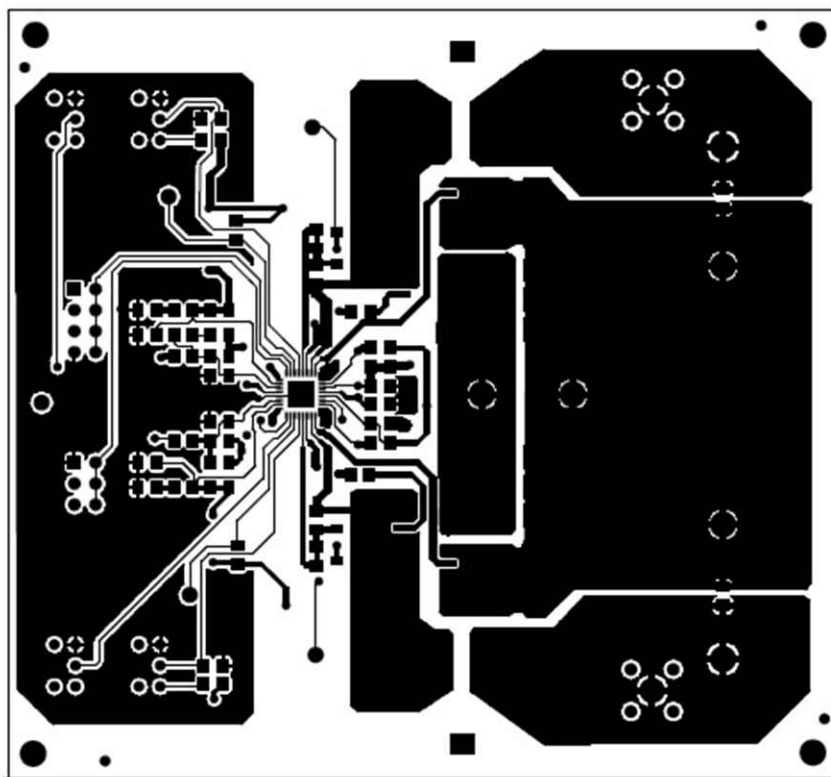

Figure 6-3. Top Layer

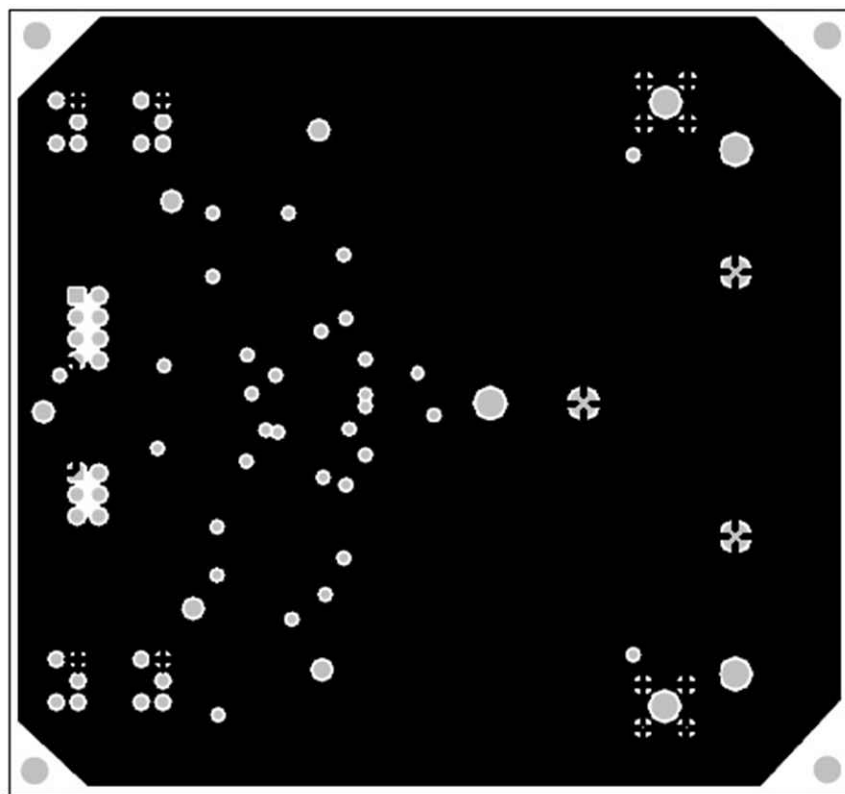

Figure 6-4. Inner Layer 1

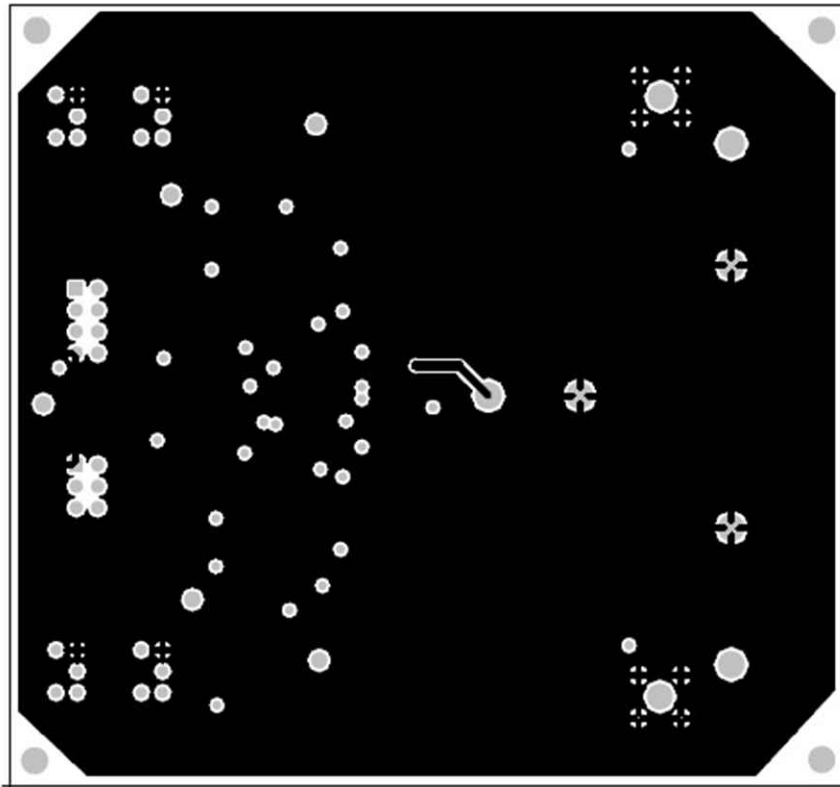

Figure 6-5. Inner Layer 2

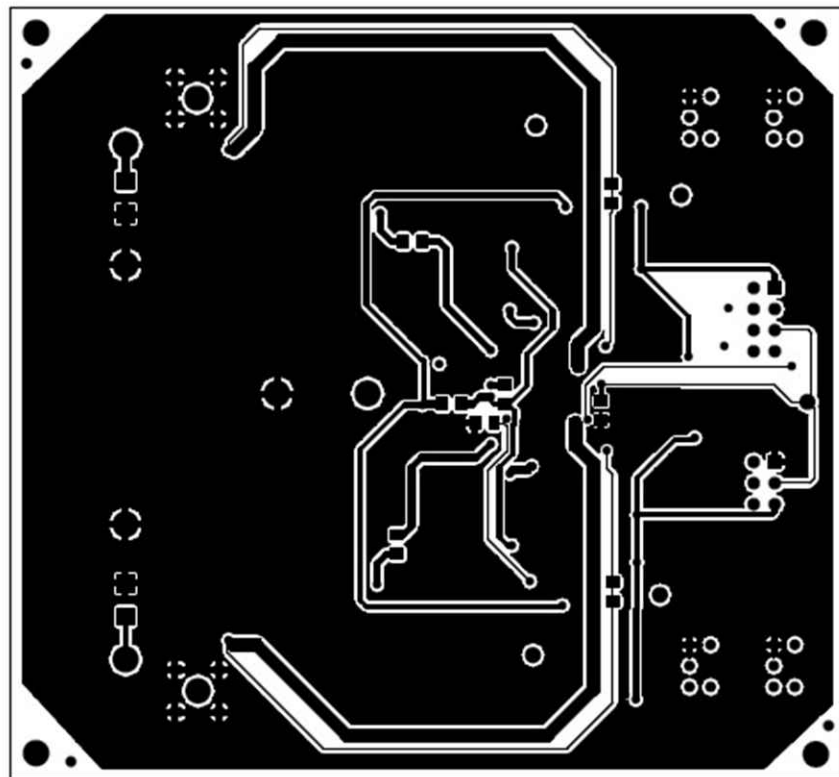

Figure 6-6. Bottom Layer

## 7 List of Materials

Reference Designator	QTY	Description	Size	Mfr	Part Number
—	2	Shunt, 100 mil, Black	0.100	3M	929950-00
C1, C24	0	Capacitor, Ceramic	1210	Any	Any
C13	1	Capacitor, Ceramic, 1 mF, 6.3 V, BJ, 20%	0805	TDK	C2012X5R0J105K
C16, C17	2	Capacitor, Ceramic, 10 mF, 6.3 V, BJ, 20%	0805	TDK	C2012X5R0J106K
C2, C3, C25, C26	4	Capacitor, Ceramic, 10 mF, 25 V, BJ, 20%	1210	Taiyo Yuden	TMK325BJ106MM
C4, C7, C9, C11, C12, C14, C15, C19, C27	0	Capacitor, Ceramic	0805	Any	Any
C5, C18, C22	3	Capacitor, Ceramic, 1 nF, 50 V, BJ, 20%	0805	Std	Std
C6, C23	2	Capacitor, Ceramic, 0.1 mF, 50 V, BJ, 20%	0805	Std	Std
C8, C10, C20, C21	4	Capacitor, POSCAP, 150 mF, 6.3 V, 55 mW, 20%	7343	SANYO	6TPB150ML
CN1, CN2	2	Adaptor, 3.5-mm probe clip (or 131-5031-00)	0.2	Tektronix	131-4244-00
D1, D4	0	Diode, Schottky, 0.5 A, 30 V	SOD-123	Any	Any
D2, D3	0	Diode, Schottky, 1 A, 30 V	SMA	Any	Any
JP1	1	Header, 2 × 4 pin, 100-mil spacing (36-pin strip)	0.20 × 0.40 inch	Sullins	PTC36DAAN
JP2	1	Header, 2 × 3 pin, 100-mil spacing (36-pin strip)	0.20 × 0.30 inch	Sullins	PTC36DAAN
L1	1	Inductor, 4.7 μH, 12.8 A, 8.8 mW	0.496 × 0.532 inch	Toko	FDA1254-4R7M
L2	1	Inductor, 2.2 μH, 17.8 A, 4.5 mW	0.496 × 0.532 inch	Toko	FDA1254-2R2M
Q1, Q4	2	MOSFET, N-ch, 30 V, 11 A, 9.1 mW	SO8	IR	IRF7821
Q2, Q3	2	MOSFET, N-ch, 30 V, 16 A, 4.0 mW	SO8	IR	IRF7832
R1, R2, R5, R8, R9, R11–R15, R20–R22, R24, R25, R27, R31, R32	0	Resistor, Chip	0805	Any	Any
R10, R26	2	Resistor, Chip, 100 kW, 1/10W, 1%	0805	Std	Std
R16, R23	0	Resistor, Metal Strip, 1 W, 1%	2512	Std	Std
R17	1	Resistor, Chip, 3.6 kW, 1/10W, 1%	0805	Std	Std
R19	1	Resistor, Chip, 3.3 kW, 1/10W, 1%	0805	Std	Std
R29	1	Resistor, Chip, 17.2 kW, 1/10W, 1%	0805	Std	Std
R3, R6, R28	3	Resistor, Chip, 7.5 kW, 1/10W, 1%	0805	Std	Std
R4	1	Resistor, Chip, 30 kW, 1/10W, 1%	0805	Std	Std
R7, R18, R30	3	Resistor, Chip, 5.1 W, 1/10W, 1%	0805	Std	Std
SW1, SW2, SW3, SW4	4	Switch, ON-ON Mini Toggle	0.28 × 0.18 inch	Nikkai	G12AP
TP1–TP5	5	Pin, Probe monitor	0.12(D) × 0.4 inch	MillMax or MAC8	LC-2-S
U1	1	IC, Dual Current Mode, Sync. Step-down Controller	QFN32	TI	TPS51120RHB
VO1, VO2, VO1_GND1, VO2_GND1, VBAT_GND1, VBAT1	6	Pin, Wiring Terminal	0.12(D) × 0.4 inch	MillMax or MAC8	3183-2-00-15-00-00-080 or WT-3-1

## 8 References

Texas Instruments, [TPS51120 Dual Current Mode, Synchronous Step-Down Controller](#) data sheet

## 9 Revision History

NOTE: Page numbers for previous revisions may differ from page numbers in the current version.

Changes from Revision A (February 2006) to Revision B (March 2022)	Page
• Updated the numbering format for tables, figures, and cross-references throughout the document. ....	2
• Updated the user's guide title.....	2

## IMPORTANT NOTICE AND DISCLAIMER

TI PROVIDES TECHNICAL AND RELIABILITY DATA (INCLUDING DATASHEETS), DESIGN RESOURCES (INCLUDING REFERENCE DESIGNS), APPLICATION OR OTHER DESIGN ADVICE, WEB TOOLS, SAFETY INFORMATION, AND OTHER RESOURCES "AS IS" AND WITH ALL FAULTS, AND DISCLAIMS ALL WARRANTIES, EXPRESS AND IMPLIED, INCLUDING WITHOUT LIMITATION ANY IMPLIED WARRANTIES OF MERCHANTABILITY, FITNESS FOR A PARTICULAR PURPOSE OR NON-INFRINGEMENT OF THIRD PARTY INTELLECTUAL PROPERTY RIGHTS.

These resources are intended for skilled developers designing with TI products. You are solely responsible for (1) selecting the appropriate TI products for your application, (2) designing, validating and testing your application, and (3) ensuring your application meets applicable standards, and any other safety, security, regulatory or other requirements.

These resources are subject to change without notice. TI grants you permission to use these resources only for development of an application that uses the TI products described in the resource. Other reproduction and display of these resources is prohibited. No license is granted to any other TI intellectual property right or to any third party intellectual property right. TI disclaims responsibility for, and you fully indemnify TI and its representatives against any claims, damages, costs, losses, and liabilities arising out of your use of these resources.

TI's products are provided subject to [TI's Terms of Sale](#), [TI's General Quality Guidelines](#), or other applicable terms available either on [ti.com](http://ti.com) or provided in conjunction with such TI products. TI's provision of these resources does not expand or otherwise alter TI's applicable warranties or warranty disclaimers for TI products. Unless TI explicitly designates a product as custom or customer-specified, TI products are standard, catalog, general purpose devices.

TI objects to and rejects any additional or different terms you may propose.

Copyright © 2026, Texas Instruments Incorporated

Last updated 10/2025