

Revision History				
Rev	ECN #	Approved Date	Approved by	Notes
N/A	N/A	N/A	N/A	N/A

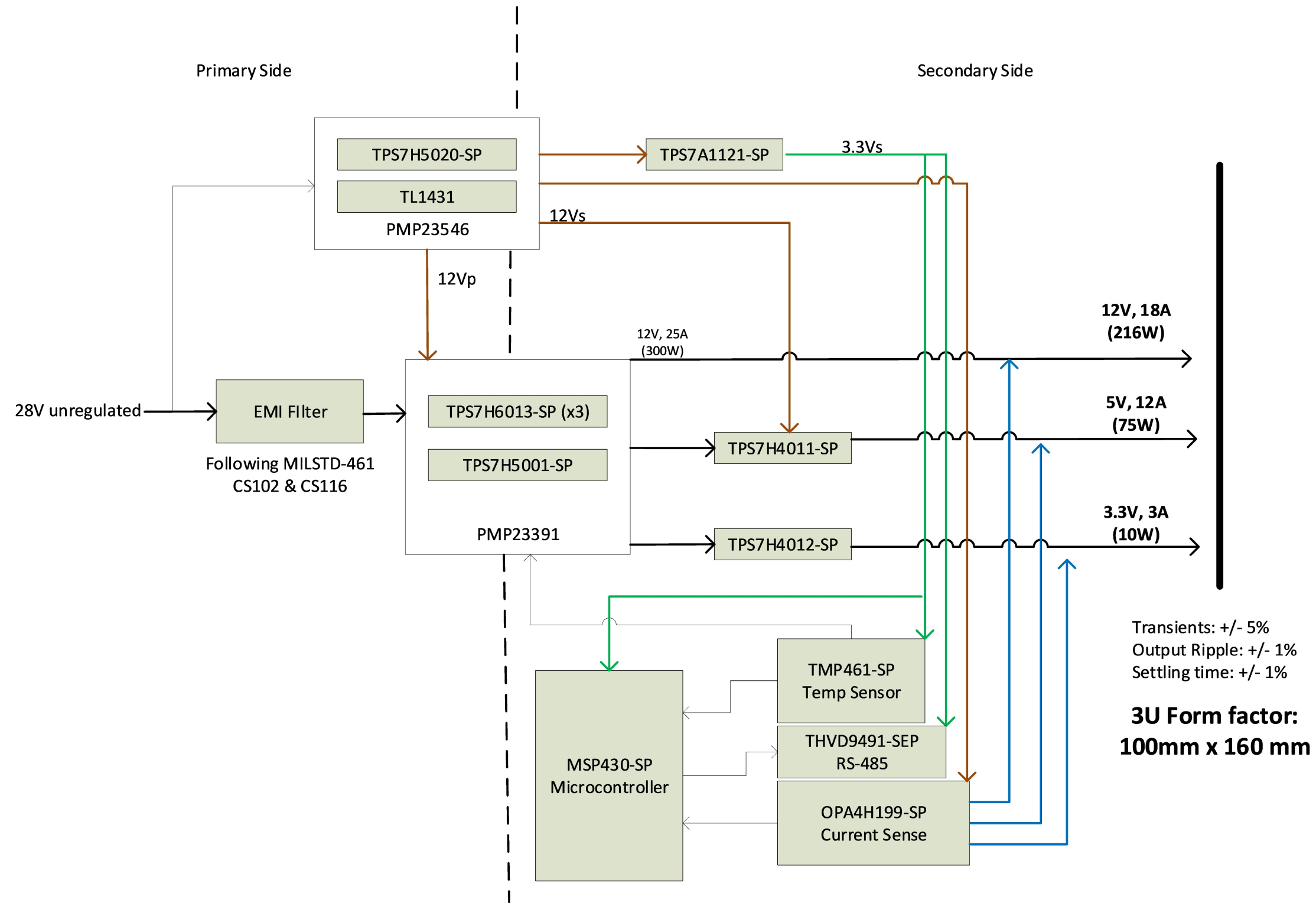

Texas Instruments and/or its licensors do not warrant the accuracy or completeness of this specification or any information contained therein. Texas Instruments and/or its licensors do not warrant that this design will meet the specifications, will be suitable for your application or fit for any particular purpose, or will operate in an implementation. Texas Instruments and/or its licensors do not warrant that the design is production worthy. You should completely validate and test your design implementation to confirm the system functionality for your application.

Orderable: ChangeMe in variant	Designed for: Public Release	Mod. Date: 11/11/2025	 http://www.ti.com © Texas Instruments 2025
TID #: N/A	Project Title: Space 3U VPX PSU		
Number: TIDA-011004	Rev: V1	Sheet Title:	
SVN Rev: Not in version control	Assembly Variant: 001	Sheet: 1 of 8	
Drawn By:	File: Block Diagram.SchDoc	Size: B	
Engineer: Bhavika Kagathi	Contact: http://www.ti.com/support		

Revision History				
Rev	ECN #	Approved Date	Approved by	Notes
N/A	N/A	N/A	N/A	N/A

3 input block terminal outside +/- and ground in the middle

Rev 2. Changed inductor to fit on board

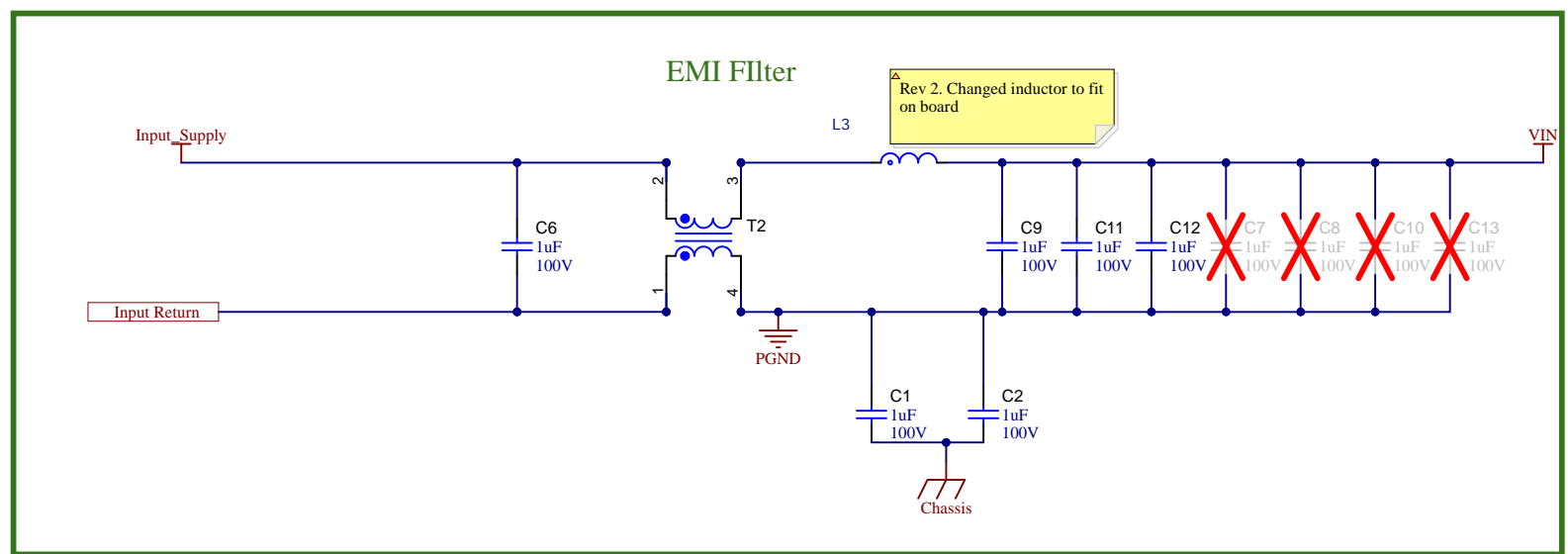

22 - 36 V input

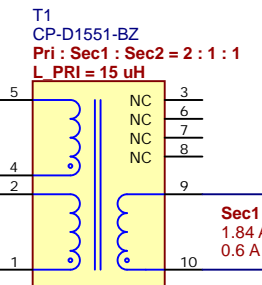
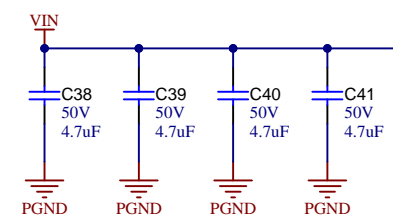

+12 V secondary bias

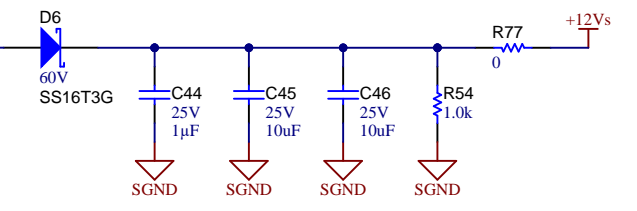

+12 V primary bias

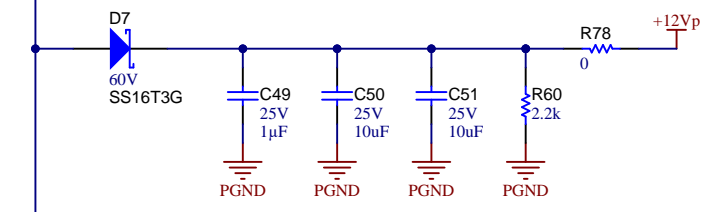

Adding R77 and R78 to easily disconnect the bias supply for testing purposes

NCs are tied to ground per data sheet to prevent charge buildup

Texas Instruments and/or its licensors do not warrant the accuracy or completeness of this specification or any information contained therein. Texas Instruments and/or its licensors do not warrant that this design will meet the specifications, will be suitable for your application or fit for any particular purpose, or will operate in an implementation. Texas Instruments and/or its licensors do not warrant that the design is production worthy. You should completely validate and test your design implementation to confirm the system functionality for your application.

22-36 Vin, 28 Vnom

12V / 25 A max

2.06 Arms ripple

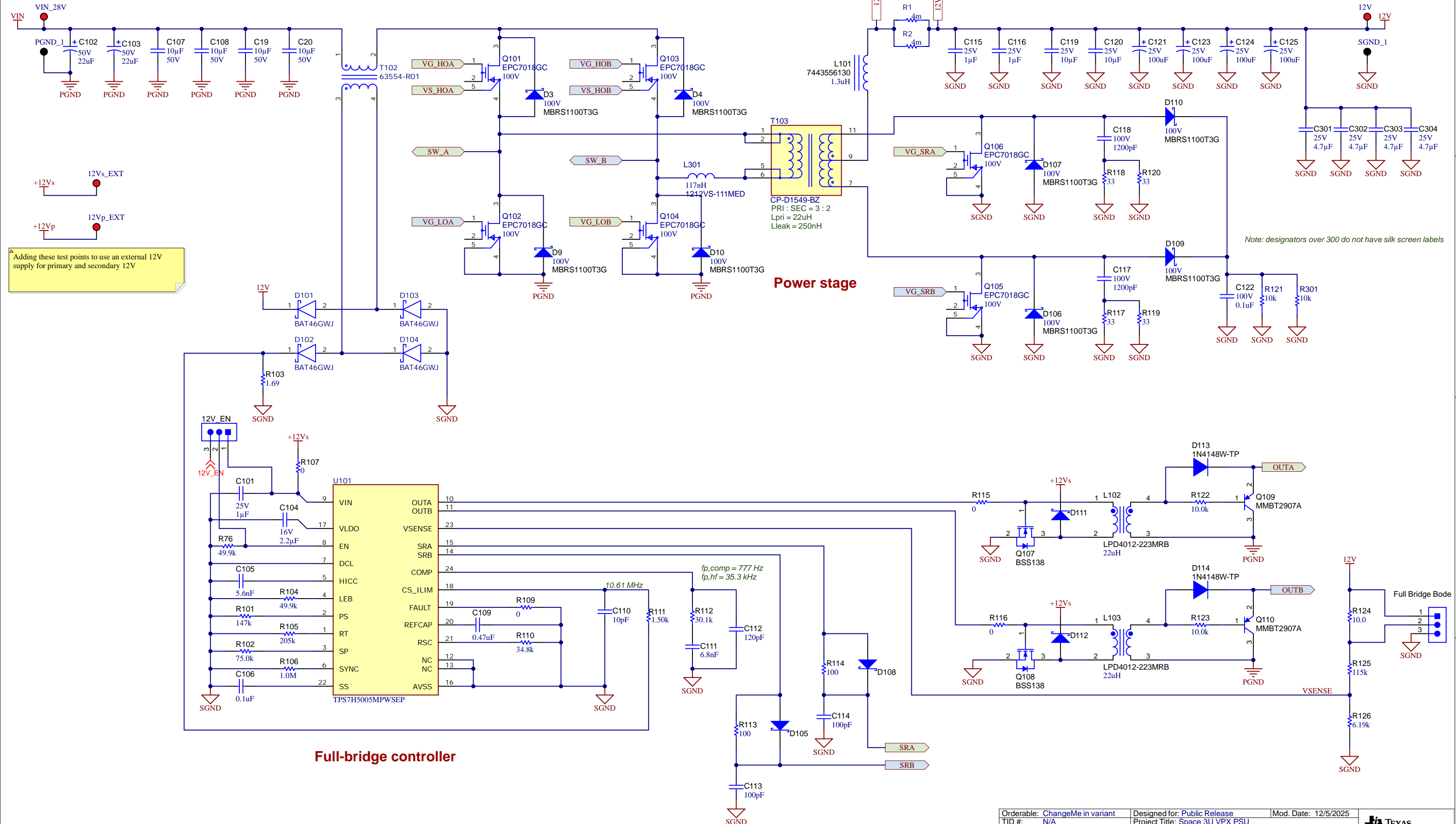

Adding these test points to use an external 12V supply for primary and secondary 12V

Note: designators over 300 do not have silk screen labels

Full-bridge controller

Power stage

Full Bridge Bode

Orderable: ChangeMe in variant	Designed for: Public Release	Mod. Date: 12/5/2025
TID #: N/A	Project Title: Space 3U VPX PSU	
Number: TIDA-011004	Rev: V1	Sheet Title:
SVN Rev: N/A	Assembly Variant: 001	Sheet: 3 of 8
Drawn By:	File: 28V to 12V.SchDoc	Size: B
Engineer: Bhavika Kagathi	Contact: http://www.ti.com/support	

Texas Instruments and/or its licensors do not warrant the accuracy or completeness of this specification or any information contained therein. Texas Instruments and/or its licensors do not warrant that this design will meet the specifications, will be suitable for your application or fit for any particular purpose, or will operate in an implementation. Texas Instruments and/or its licensors do not warrant that the design is production worthy. You should completely validate and test your design implementation to confirm the system functionality for your application.



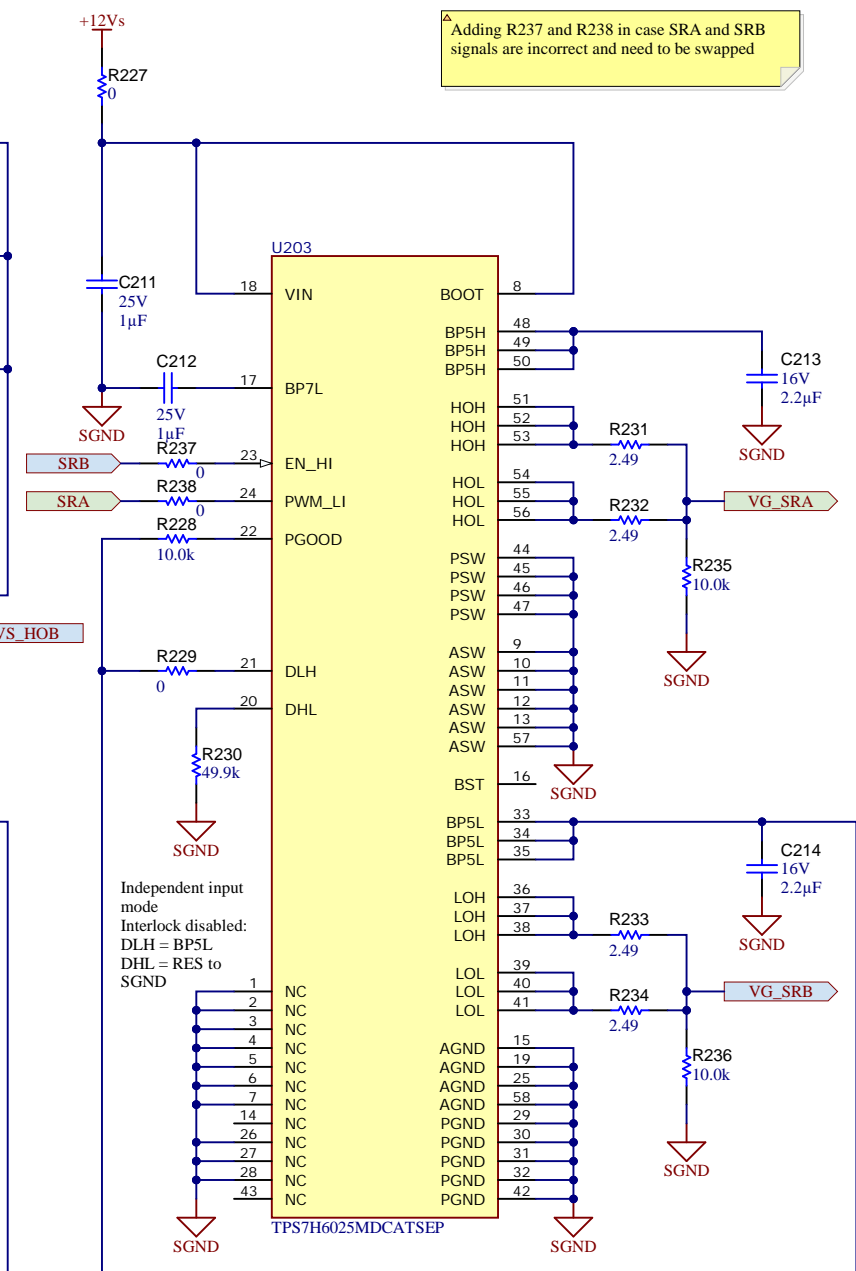
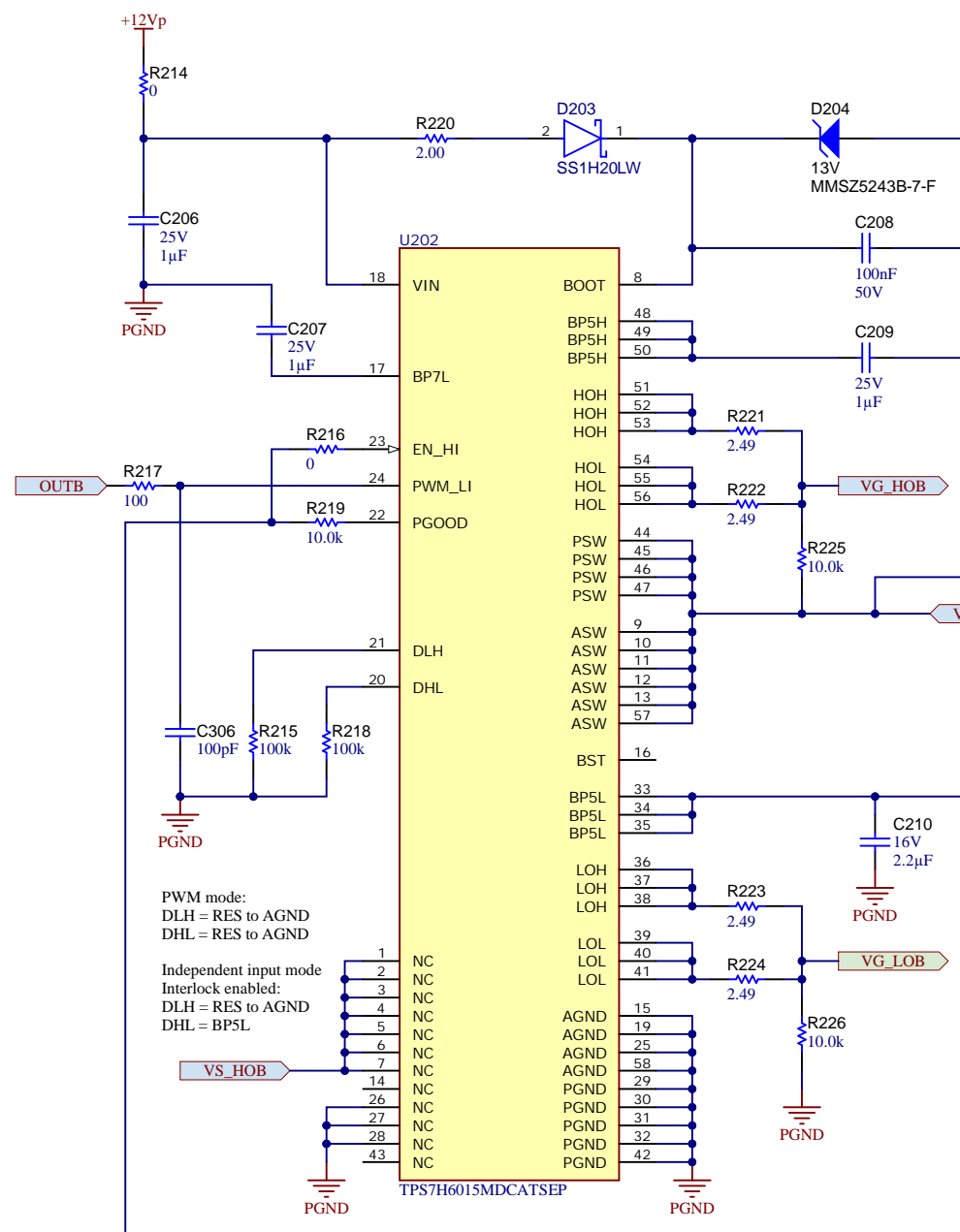
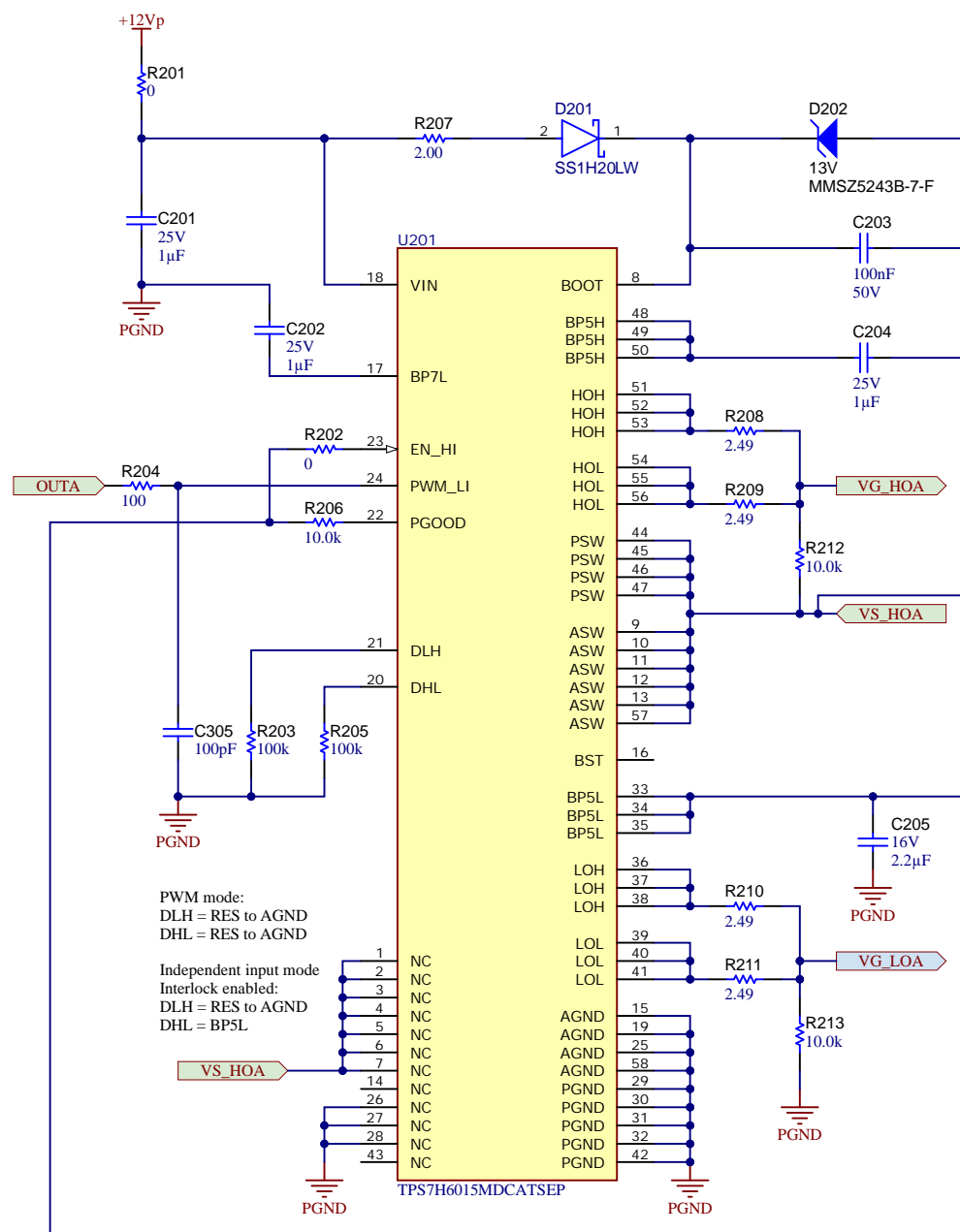

Adding R237 and R238 in case SRA and SRB signals are incorrect and need to be swapped

Primary FET drivers

Secondary rectifier drivers

Texas Instruments and/or its licensors do not warrant the accuracy or completeness of this specification or any information contained therein. Texas Instruments and/or its licensors do not warrant that this design will meet the specifications, will be suitable for your application or fit for any particular purpose, or will operate in an implementation. Texas Instruments and/or its licensors do not warrant that the design is production worthy. You should completely validate and test your design implementation to confirm the system functionality for your application.

Orderable: ChangeMe in variant	Designed for: Public Release	Mod. Date: 12/4/2025
TID #: N/A	Project Title: Space 3U VPX PSU	
Number: TIDA-011004	Rev: V1	Sheet: 4 of 8
SVN Rev: Not in version control	Assembly Variant: 001	Size: B
Drawn By:	File: 28V to 12V drivers_SchDoc	
Engineer: Bhavika Kagathi	Contact: http://www.ti.com/support	



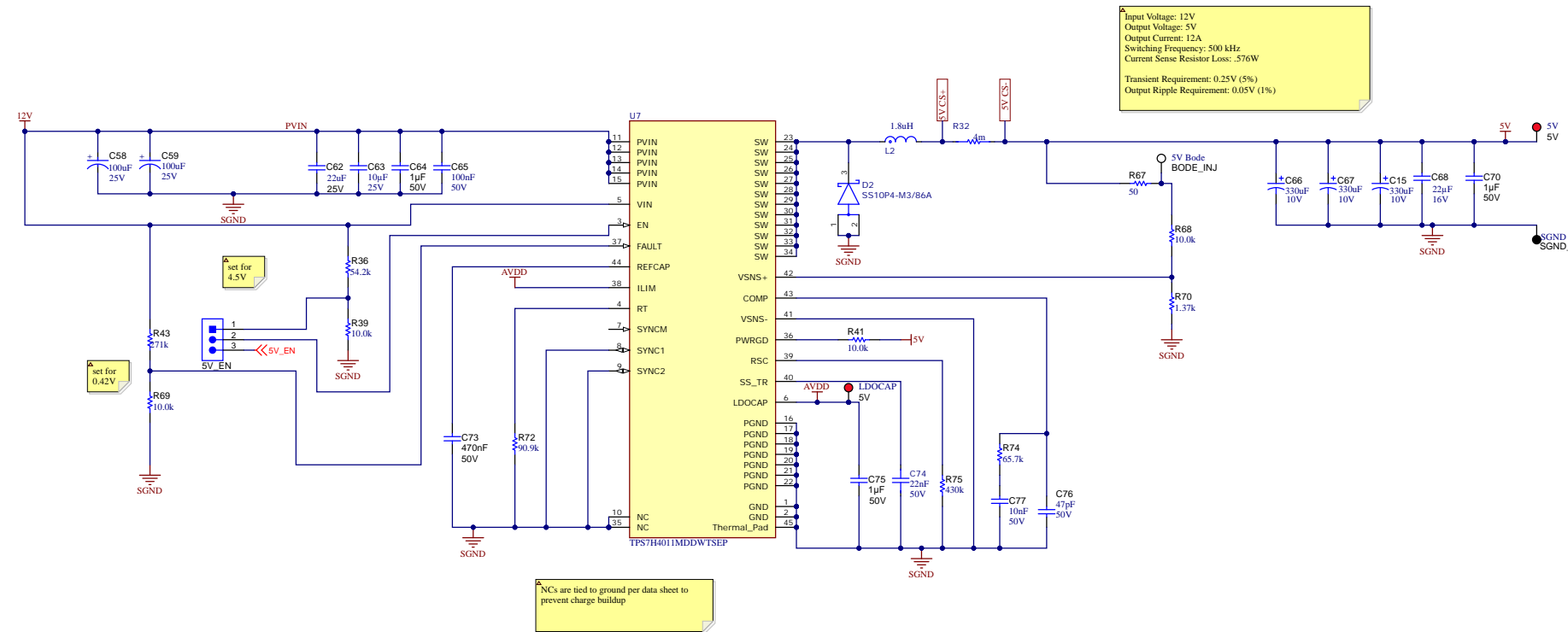

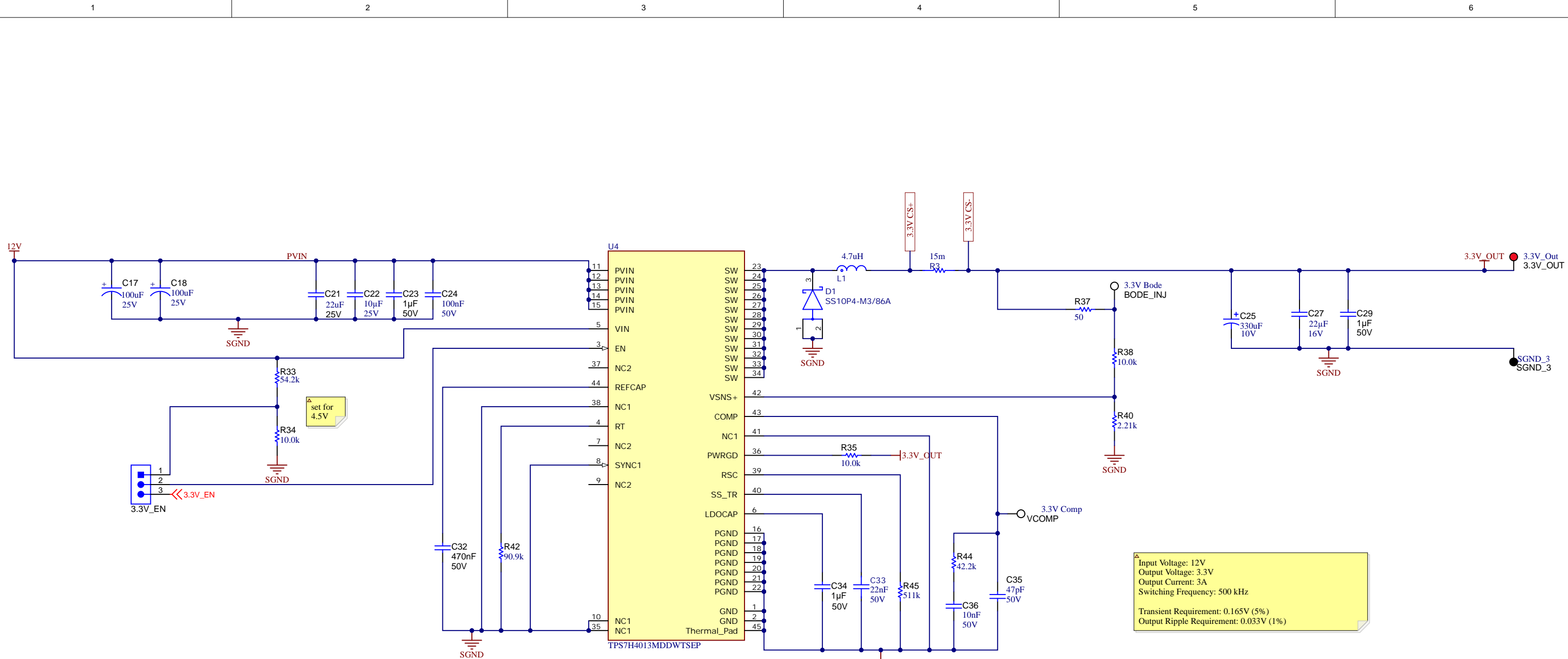

NCs are tied to ground per data sheet to prevent charge buildup

Input Voltage: 12V
 Output Voltage: 3.3V
 Output Current: 3A
 Switching Frequency: 500 kHz
 Transient Requirement: 0.165V (5%)
 Output Ripple Requirement: 0.033V (1%)

Texas Instruments and/or its licensors do not warrant the accuracy or completeness of this specification or any information contained therein. Texas Instruments and/or its licensors do not warrant that this design will meet the specifications, will be suitable for your application or fit for any particular purpose, or will operate in an implementation. Texas Instruments and/or its licensors do not warrant that the design is production worthy. You should completely validate and test your design implementation to confirm the system functionality for your application.

Orderable: ChangeMe in variant	Designed for: Public Release	Mod. Date: 11/18/2025
TID #: N/A	Project Title: Space 3U VPX PSU	
Number: TIDA-011004	Rev: V1	Sheet: 6 of 8
SVN Rev: Not in version control	Assembly Variant: 001	Size: B
Drawn By:	File: 12 to 3.3V.SchDoc	
Engineer: Bhavika Kagathi	Contact: http://www.ti.com/support	

<http://www.ti.com>
 © Texas Instruments 2025

Overcurrent Protection for 12V, 5V, 3.3V

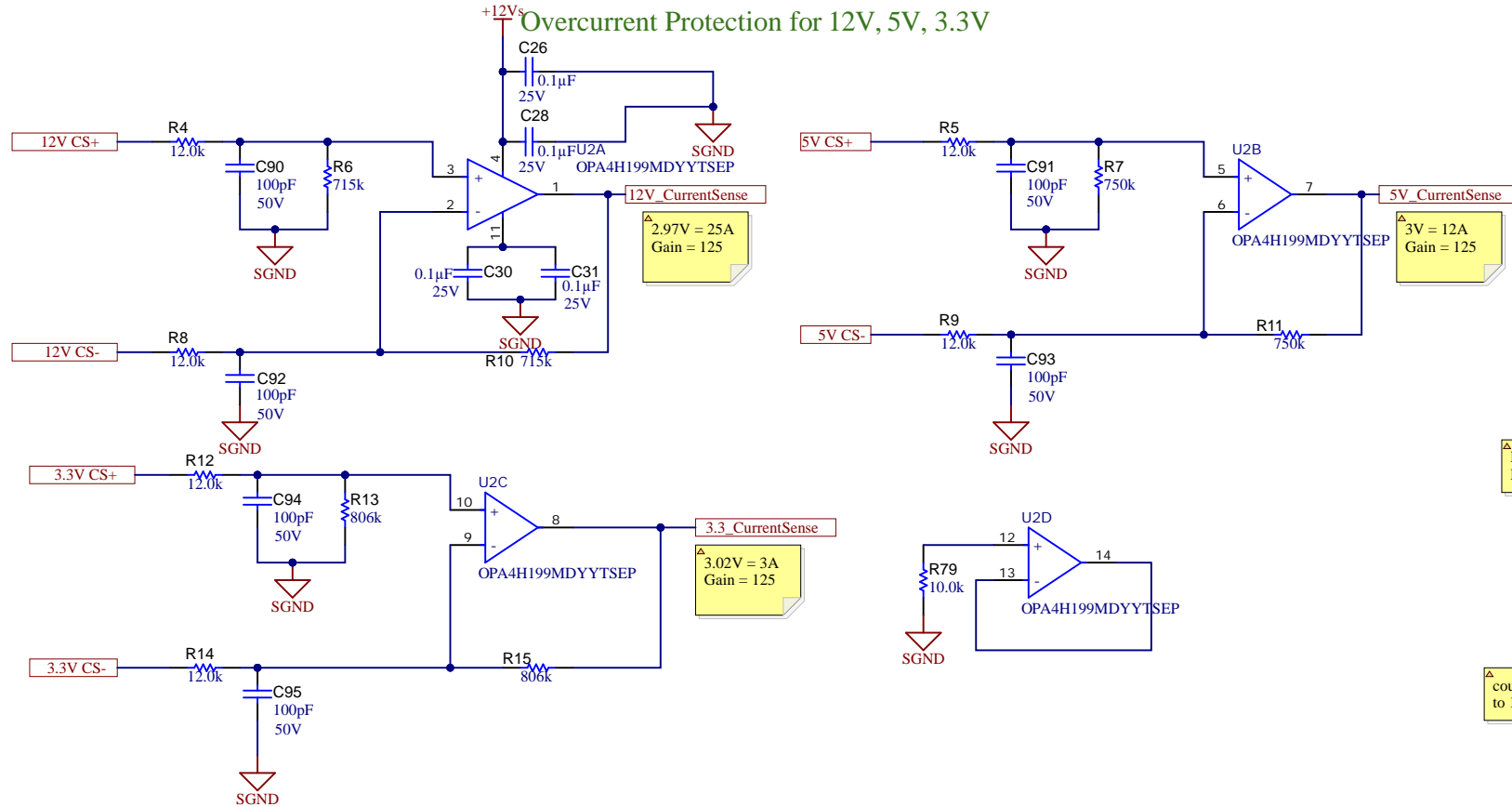

Temperature Sensing

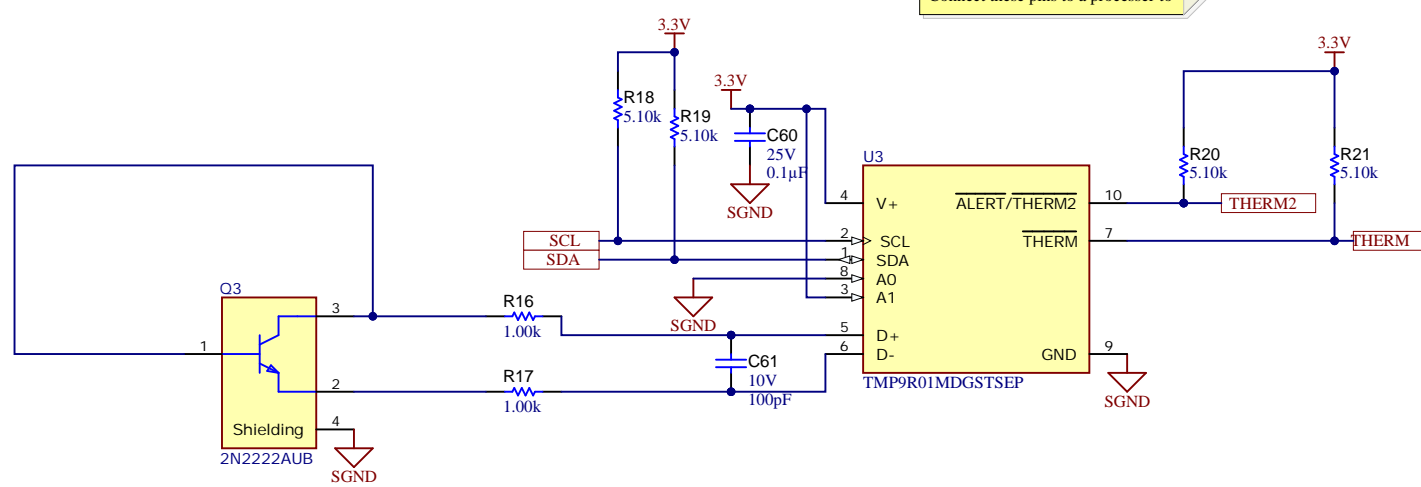

RS-485 Interface

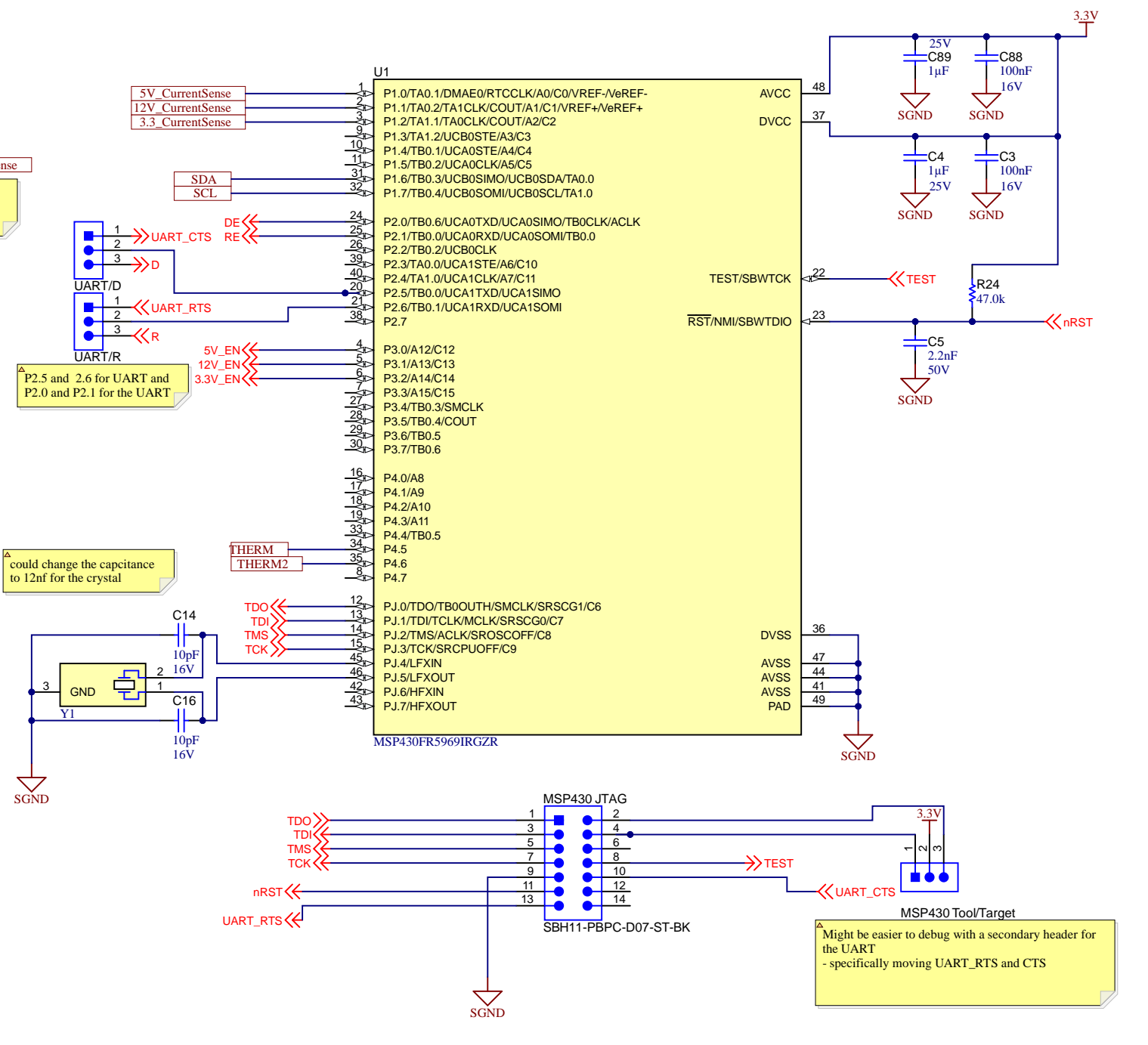
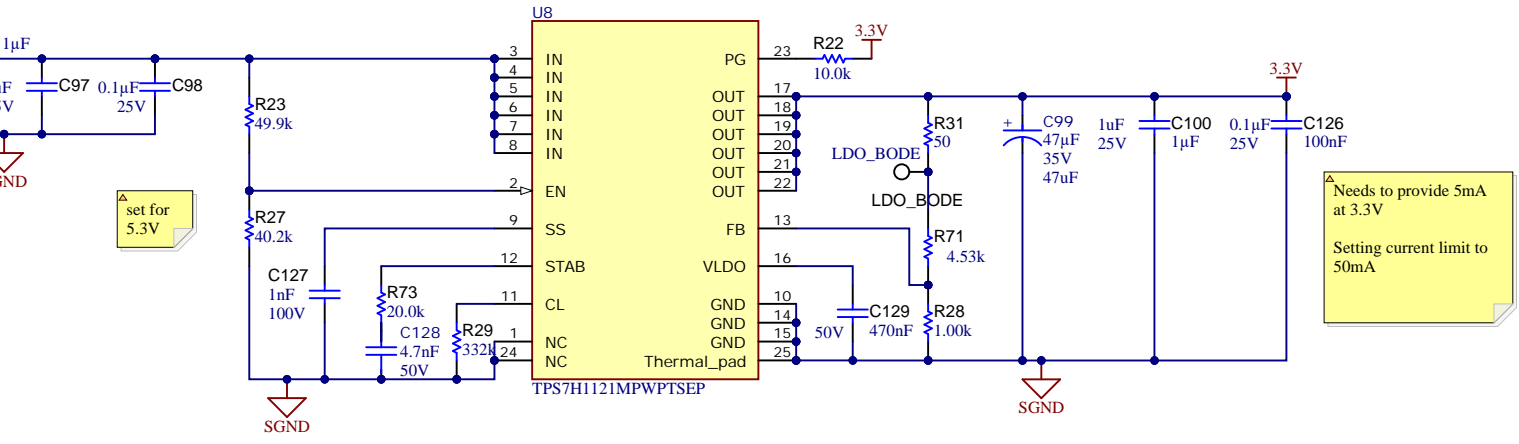
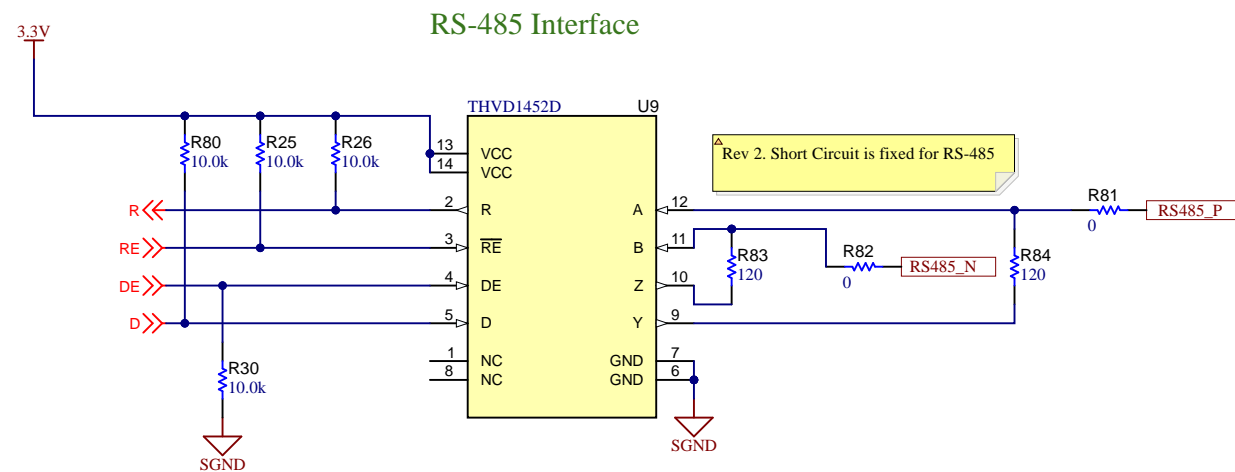

Texas Instruments and/or its licensors do not warrant the accuracy or completeness of this specification or any information contained therein. Texas Instruments and/or its licensors do not warrant that this design will meet the specifications, will be suitable for your application or fit for any particular purpose, or will operate in an implementation. Texas Instruments and/or its licensors do not warrant that the design is production worthy. You should completely validate and test your design implementation to confirm the system functionality for your application.

Orderable: ChangeMe in variant	Designed for: Public Release	Mod. Date: 4/30/2026
TID #: N/A	Project Title: Space 3U VPX PSU	
Number: TIDA-011004	Rev: V1	Sheet Title:
SVN Rev: Not in version control	Assembly Variant: 001	Sheet: 7 of 8
Drawn By:	File: Telemetry_SchDoc	Size: B
Engineer: Bhavika Kagathi	Contact: http://www.ti.com/support	

TEXAS INSTRUMENTS
http://www.ti.com
© Texas Instruments 2025

IMPORTANT NOTICE AND DISCLAIMER

TI PROVIDES TECHNICAL AND RELIABILITY DATA (INCLUDING DATASHEETS), DESIGN RESOURCES (INCLUDING REFERENCE DESIGNS), APPLICATION OR OTHER DESIGN ADVICE, WEB TOOLS, SAFETY INFORMATION, AND OTHER RESOURCES "AS IS" AND WITH ALL FAULTS, AND DISCLAIMS ALL WARRANTIES, EXPRESS AND IMPLIED, INCLUDING WITHOUT LIMITATION ANY IMPLIED WARRANTIES OF MERCHANTABILITY, FITNESS FOR A PARTICULAR PURPOSE OR NON-INFRINGEMENT OF THIRD PARTY INTELLECTUAL PROPERTY RIGHTS.

These resources are intended for skilled developers designing with TI products. You are solely responsible for (1) selecting the appropriate TI products for your application, (2) designing, validating and testing your application, and (3) ensuring your application meets applicable standards, and any other safety, security, regulatory or other requirements.

These resources are subject to change without notice. TI grants you permission to use these resources only for development of an application that uses the TI products described in the resource. Other reproduction and display of these resources is prohibited. No license is granted to any other TI intellectual property right or to any third party intellectual property right. TI disclaims responsibility for, and you fully indemnify TI and its representatives against any claims, damages, costs, losses, and liabilities arising out of your use of these resources.

TI's products are provided subject to [TI's Terms of Sale](#), [TI's General Quality Guidelines](#), or other applicable terms available either on ti.com or provided in conjunction with such TI products. TI's provision of these resources does not expand or otherwise alter TI's applicable warranties or warranty disclaimers for TI products. Unless TI explicitly designates a product as custom or customer-specified, TI products are standard, catalog, general purpose devices.

TI objects to and rejects any additional or different terms you may propose.

Copyright © 2026, Texas Instruments Incorporated

Last updated 10/2025