

TLC6C5712-Q1 Evaluation Module

1 Introduction

This document is the user's guide for the TLC6C5712-Q1 evaluation module (EVM) as a supplement to the TLC6C5712-Q1 data sheet. This user's guide describes the characteristics, operation, and use of the TLC6C5712-Q1 EVM. This EVM is designed to help the user evaluate and test the various operating modes of the TLC6C5712-Q1 device. This user's guide includes a detailed description of the graphical user interface (GUI) which can help customers easily use the GUI. The guide also contains the setup instructions for the hardware and software, a schematic diagram, a bill of materials (BOM), and PCB layout drawings for the evaluation module.

The TLC6C5712-Q1 device is a 12 channel, constant-current LED driver that is capable of driving up to 75 mA per channel. The device contains an integrated DOT-correction circuitry which can adjust the DC current for each output channel to compensate for a difference in brightness among the LEDs. The device also has integrated PWM mapping control to provide individual LED PWM dimming. The device has full LED diagnostics, such as LED open, LED short, output short to GND, over-temperature prewarning, over-temperature thermal shutdown, reference short and open, adjacent pin short, and others. This EVM can be used to evaluate a single device, but it can be also configured to drive two devices in a cascade configuration. By using the GUI, users can easily evaluate the device.

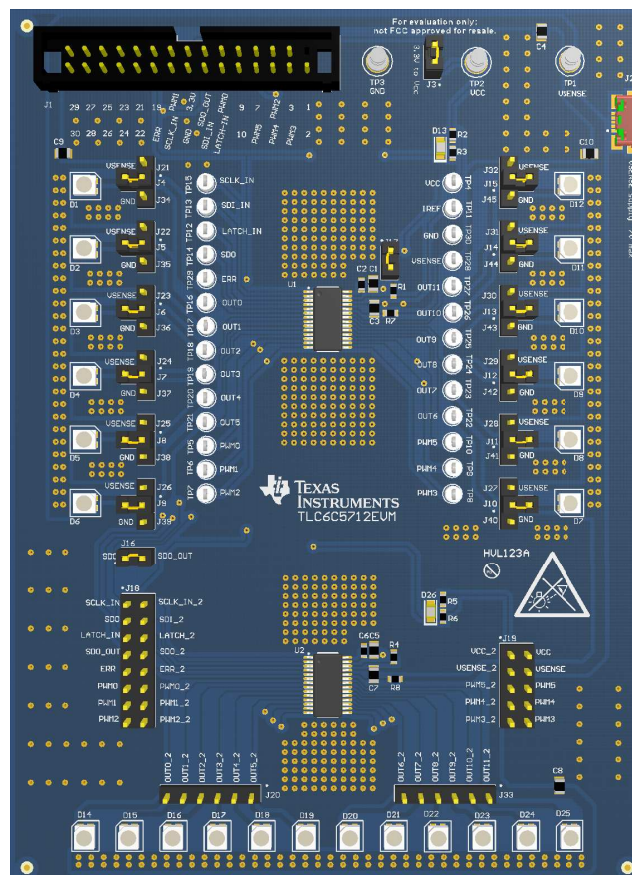

Figure 1. Top View of the TLC6C5712-Q1EVM PCB

2 Requirements

To operate this EVM, the software, power supply, and communication board must be connected and properly configured. This section provides more information on each component.

2.1 Software

Texas Instruments has provided the necessary software to evaluate this EVM. For the latest software revision, go to the TLC6C5712-Q1 product folder, www.ti.com/product/TLC6C5712-Q1.

2.2 Power Supply Requirements

The EVM board can receive supply in one of two ways. The first way is suitable for evaluation in the lab which uses two DC power supplies. The first DC power supply is for V_{CC} and the other is for VSENSE. The second way is suitable for portable demonstration. In this case, only a 5-V micro-USB supply is required. The VSENSE pin can be powered through a USB cable directly and the V_{CC} pin can be directly supplied by the USB2ANY.

2.3 Communication Board

The USB2ANY is the interface between the PC and the TLC6C5712-Q1EVM. One end of the USB2ANY connects to the PC with the USB cable and the other end of the USB2ANY connects to the EVM with the ribbon cable. After installing the GUI, users can control the TLC6C5712-Q1EVM by sending commands through the USB2ANY.

3 Setup

The following sections describe how to setup the EVM hardware and software.

3.1 Hardware Setup

Figure 2 shows the hardware setup of the TLC6C5712-Q1EVM.

- Step 1. Connect the 5-V power supply to the LED board between TP1 (VSENSE) and TP3 (GND). Users can also use the 5-V micro-USB supply connected to J2 to supply VSENSE.
- Step 2. Put a shunt on J3 to connect the USB2ANY 3.3-V supply to V_{CC} . In this case, the user is not required to supply V_{CC} with another DC supply.
- Step 3. Connect the host computer to USB2ANY board using the USB cable.
- Step 4. Connect the ribbon cable between the USB2ANY board and the TLC6C5712-Q1 EVM board.

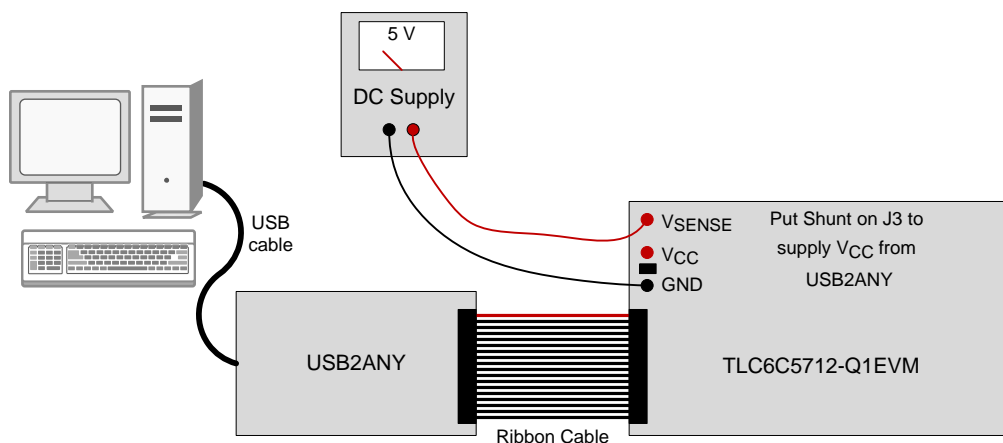

Figure 2. Hardware Setup for TLC6C5712-Q1EVM

3.2 Software Installation

Download the GUI software from www.ti.com. After downloading, install the TLC6C5712-Q1 EVM GUI on the PC. A shortcut to the GUI is found on the desktop. A shortcut can also be found in the startup menu under the *Texas Instruments* folder.

3.3 GUI Connection

After setting up the hardware, open the GUI. **Figure 3** shows the overview of the TLC6C5712-Q1 EVM GUI. When the EVM is connected correctly, the status bar at the bottom right of the GUI will show a green *CONNECTED* status. A red *SIMULATION* status indicates that the device is not connected. Check the connection of the device to make sure that it is properly connected. If the *SIMULATION* status still appears, then uncheck the *Simulate Communication* box in the top right of the GUI to connect the device.

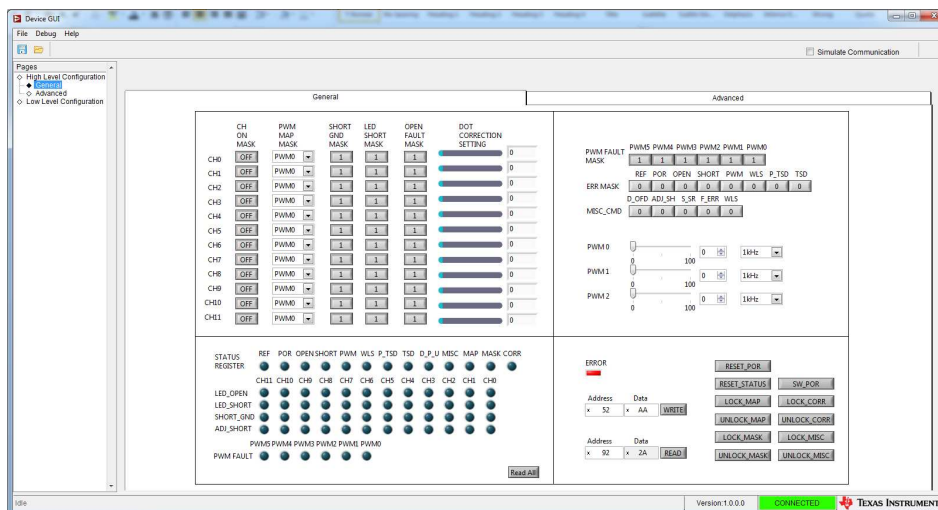

Figure 3. TLC6C5712-Q1 EVM GUI Overview

4 Input and Output Connector Descriptions

4.1 Power Supply Connector

Table 1 list the connector descriptions of the power supply.

Table 1. Power Supply Connectors

CONNECTOR	NAME	DESCRIPTION
TP1	VSENSE	This connector is the positive input of the load supply
J2	VSENSE Supply	The connector is a Micro-USB connector, it can be used to supply the load by an USB cable.
TP2	VCC	This connector is the positive input of the IC internal supply.
TP3	GND	This connector is the ground of the EVM.

4.2 SPI Interface Connectors

The J1 jumper is the SPI interface connector. [Table 2](#) lists the detailed description of J1.

Table 2. SPI Interface Connector

PIN NO.	PIN SYMBOL	SIGNAL NAME	I/O	FUNCTION
1	—	—	—	—
2	—	—	—	—
3	—	—	—	—
4	PWM3	PWM3	Input	PWM input for PWM3 of U1
5	PWM2	PWM2	Input	PWM input for PWM2 of U1
6	PWM4	PWM4	Input	PWM input for PWM4 of U1
7	—	—	—	—
8	PWM5	PWM5	Input	PWM input for PWM5 of U1
9	—	—	—	—
10	—	—	—	—
11	PWM0	PWM0	Input	PWM input for PWM0 of U1
12	LATCH_IN	Serial data latch	Input	Rising edge latches data from shift registers into the device
13	SDO_OUT	Serial data output	Output	Serial data output for U1. This is also the serial data input in cascade mode.
14	SDI_IN	Serial data input	Input	Serial data input for U1
15	3.3 V	3.3-V supply	Power	3.3-V supply on USB2ANY
16	GND	Ground	Power	Signal ground
17	PWM1	PWM1	Input	PWM input for PWM1 of U1
18	SCLK_IN	Serial data clock	Input	Serial data input clock
19	—	—	—	—
20	ERR	Error output	Output	Error output for device
21	—	—	—	—
22	—	—	—	—
23	—	—	—	—
24	—	—	—	—
25	—	—	—	—
26	—	—	—	—
27	—	—	—	—
28	—	—	—	—
29	—	—	—	—
30	—	—	—	—

4.3 Test Points

Table 3 the test points of the EVM.

Table 3. Test points of the EVM

SYMBOL	NAME	FUNCTION
TP15	SCLK_IN	SPI clock input of U1
TP13	SDI_IN	SPI data input of U1
TP12	LATCH_IN	SPI latch input of U1
TP14	SDO	SPI data output of U1
TP29	ERR	ERR output of U1
TP16	OUT0	OUT0 of U1
TP17	OUT1	OUT0 of U1
TP18	OUT2	OUT0 of U1
TP19	OUT3	OUT0 of U1
TP20	OUT4	OUT0 of U1
TP21	OUT5	OUT0 of U1
TP5	PWM0	PWM0 of U1
TP6	PWM1	PWM0 of U1
TP7	PWM2	PWM0 of U1
TP4	V _{CC}	V _{CC} of U1
TP11	IREF	I _{ref} of U1
TP30	GND	GND
TP28	VSENSE	VSENSE of U1
TP27	OUT11	OUT0 of U1
TP26	OUT10	OUT0 of U1
TP25	OUT9	OUT0 of U1
TP24	OUT8	OUT0 of U1
TP23	OUT7	OUT0 of U1
TP22	OUT6	OUT0 of U1
TP10	PWM5	PWM0 of U1
TP9	PWM4	PWM0 of U1
TP8	PWM3	PWM0 of U1
J21, J22, J23, J24, J25, J26, J27, J28, J29, J30, J31, J32	VSENSE	VSENSE of U1
J34, J35, J36, J37, J38, J39, J40, J41, J42, J43, J44, J45	GND	GND

4.4 Jumpers

Table 4 lists shows the jumpers of the EVM.

Table 4. Jumpers of the EVM

JUMPER	DESCRIPTION
J3	Connect 3.3 V to V_{CC}
J17	Connect REF resistor and GND
J16	Connect SDO to SDO_OUT, when controlling a single TLC6C5712-Q1 device, put a shunt on this jumper
J18	Cascade U1 with U2, when controlling U1 and U2 in series, remove shunt on J16, put shunt on J18 and J19
J19	Cascade U1 with U2, when controlling U1 and U2 in series, remove shunt on J16, put shunt on J18 and J19
J20	OUT0-5 of U2
J33	OUT6-11 of U2
J4	Connect D1 to OUT0 of U1
J5	Connect D2 to OUT1 of U1
J6	Connect D3 to OUT2 of U1
J7	Connect D4 to OUT3 of U1
J8	Connect D5 to OUT4 of U1
J9	Connect D6 to OUT5 of U1
J10	Connect D7 to OUT6 of U1
J11	Connect D8 to OUT7 of U1
J12	Connect D9 to OUT8 of U1
J13	Connect D10 to OUT9 of U1
J14	Connect D11 to OU10 of U1
J15	Connect D12 to OUT11 of U1

5 GUI Function

This section describes the details of the TLC6C5712-Q1 EVM GUI. The GUI has two configuration levels: one is a high-level configuration, the other is a low-level configuration. In the high-level configuration, two tabs are included which are for the general function and advanced function. Low-level configuration describes all the TLC6C5712-Q1 registers. The following sections introduce the details of the functions.

5.1 General

Figure 4 shows the general tab of TLC6C5712-Q1 EVM GUI. In this page, users can easily change the register values.

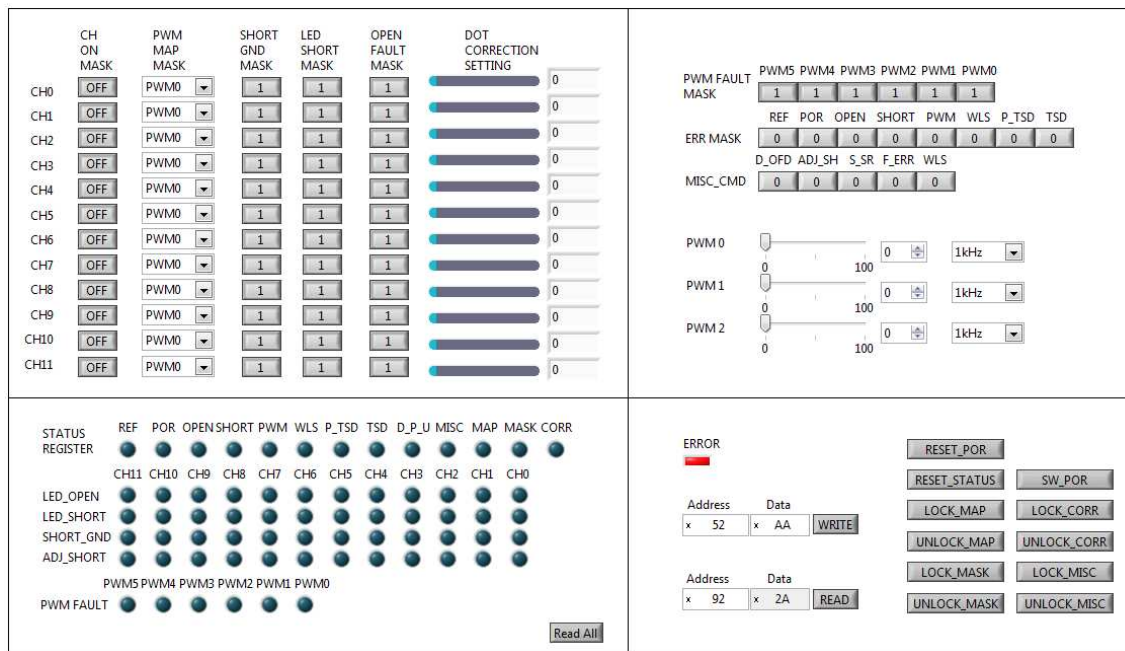

Figure 4. TLC6C5712-Q1 EVM GUI

The general tab is divided into four parts. Figure 5 shows the register control of CH ON MASK, PWM MAP MASK, SHORT GND MASK, LED SHORT MASK, OPEN FAULT MASK, and DOT CORRECTION SETTING.

The LEDs can be turned on by clicking the *CH ON MASK* button. The word on the button shows the value sent to the register. When the button displays *OFF*, the value of the CH ON MASK is 1 which means the LED is masked and the output is turned off. When the button displays *ON*, the value of the CH ON MASK is 0 which means the LED is not masked and the output is turned on.

The PWM MAP MASK is used to map the PWM control for each channel. When driving the EVM using the USB2ANY board, only three PWM outputs available: PWM0, PWM1, and PWM2. These outputs can be controlled by the sliders in Figure 6. The PWM3, PWM4 and PWM5 are connected to the GND of USB2ANY.

The SHORT GND MASK, LED SHORT MASK, and OPEN FAULT MASK are used to control the fault mask. A setting of 1 indicates that the fault is masked. A setting of 0 indicates that the fault is not masked. When the fault is unmasked, the fault will be reported to the open and short registers in the status register. SHORT GND MASK and LED SHORT MASK correspond with the status of the short register shown in Figure 7. OPEN FAULT MASK corresponds with the status of the open register shown in Figure 7.

The DOT CORRECTION SETTING is used for setting the output current for each channel. Each channel has an internal 8-bit linear current DAC for individual dot correction control. Use Equation 1 to set the output current.

$$I_{OUT} = \frac{V_{REF} \times K_{OUT}}{R_{REF}} \times \frac{DC + 1}{256}$$

where

- V_{REF} is the reference voltage, 1.229 V
- K_{OUT} is the output current to I_{REF} current ratio, 500
- R_{REF} is the reference resistor
- DC is the DOT correction setting value

(1)

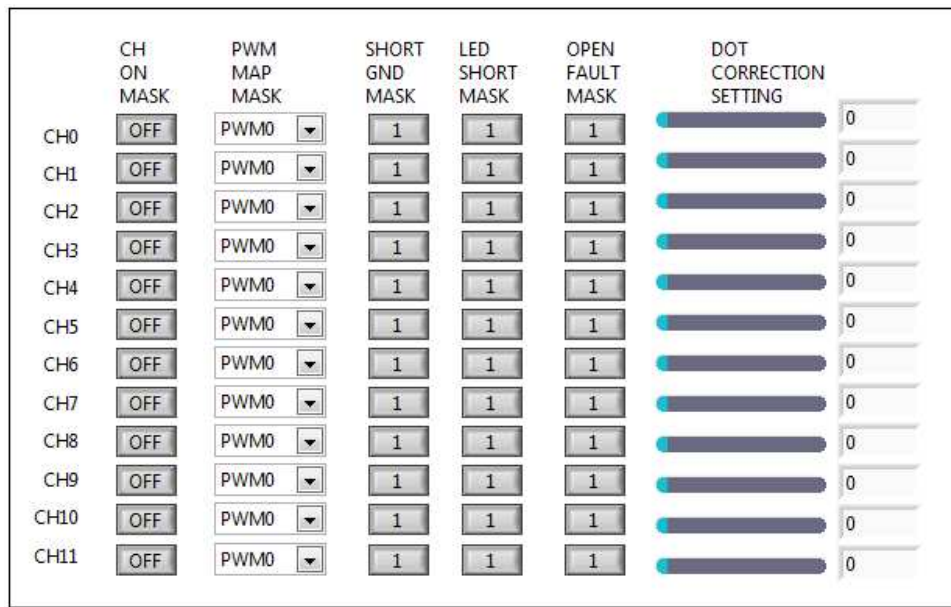

Figure 5. General Function I

PWM FAULT MASK is used to control the PWM fault mask. A setting of 1 indicates that the PWM fault is masked and therefore the fault will not be reported to the status register shown in Figure 7. A setting of 0 indicates that the PWM fault is unmasked and therefore when a PWM fault occurs, the fault will be reported to PWM status register.

The ERR MASK field is used to control the ERROR mask. A setting of 1 indicates that the error is masked and therefore the error is not reported to the ERROR indicator shown in Figure 8. A setting of 0 indicates that the error is unmasked and therefore, when an error occurs, the error is reported to the ERROR indicator. When users need the error indicator to report the fault, the fault mask for each channel (such as PWM fault mask, SHORT GND MASK, and so on) should not be masked. When D13 on the EVM is on, users can click the READ ALL to get the fault.

The MISC_CMD field contains five commands. The D_OFD command disables the off state diagnostic. If the LED off-state diagnostic is not needed, change the register value to 1. The ADJ_SH command detects the adjacent pin short fault. Users can implement the detection by setting the register value to 1. Because the register value resets to 0 after the device finishes the detection, users must change the ADJ_SH value back to 0 after the detection is complete. The S_SR command is used to control the output slew rate. A setting of 1 indicates the slow slew rate. The F_ERR command forces the ERROR output state. When the register is 1, the ERR output is pulled low even the system has no error. The WLS command configures the weak-load supply-detection threshold. A setting of 1 indicates that the detection threshold is 2.77 V. A setting of 0 indicates that the detection threshold is 4.2 V.

The PWM0, PWM1, and PWM2 fields generate the PWM control signals for the TLC6C5712-Q1 EVM. PWM0, PWM1, and PWM2 corresponds with the PWM0, PWM1, and PWM2 inputs of the TLC6C5712-Q1 device. Users can select from the following 8 frequencies: 100 Hz, 200 Hz, 500 Hz, 1 KHz, 2 KHz, 5 KHz, 10 KHz, 20 KHz, 50 KHz, and 100 KHz. The duty cycles can also be changed from 0 to 100% respectively.

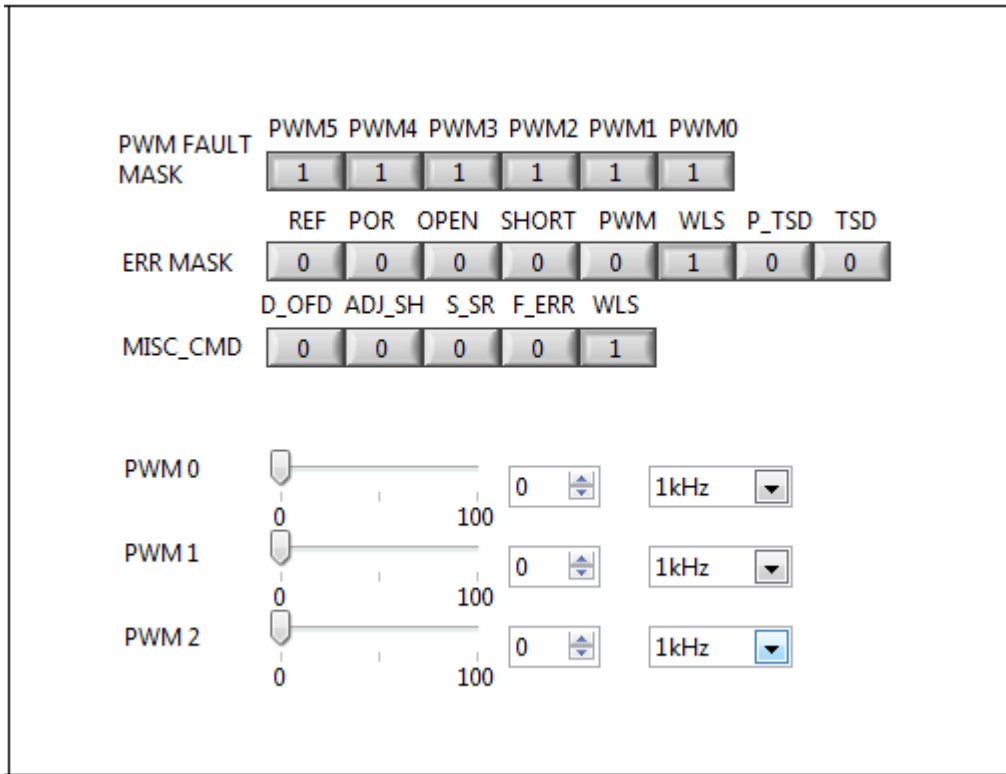

Figure 6. General Function II

Figure 7 shows the status registers and fault registers of the TLC6C5712-Q1 device. By clicking the Read All button, the information of these registers is read out. A red indicator color indicates a fault.

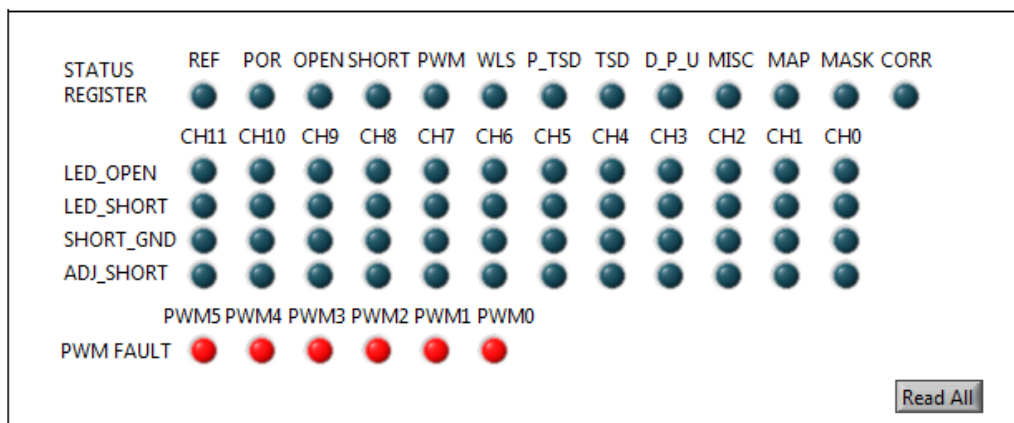

Figure 7. General Function III

Figure 8 contains registers with simple read and write functions. Users can write and read registers by input address and data value. The ERROR indicator shows the ERR pin state. If the error pin is pulled low, the ERROR indicator displays red. The left side of Figure 8 shows several special commands of TLC6C5712-Q1 device which can be found in the datasheet (SLVSCO9).

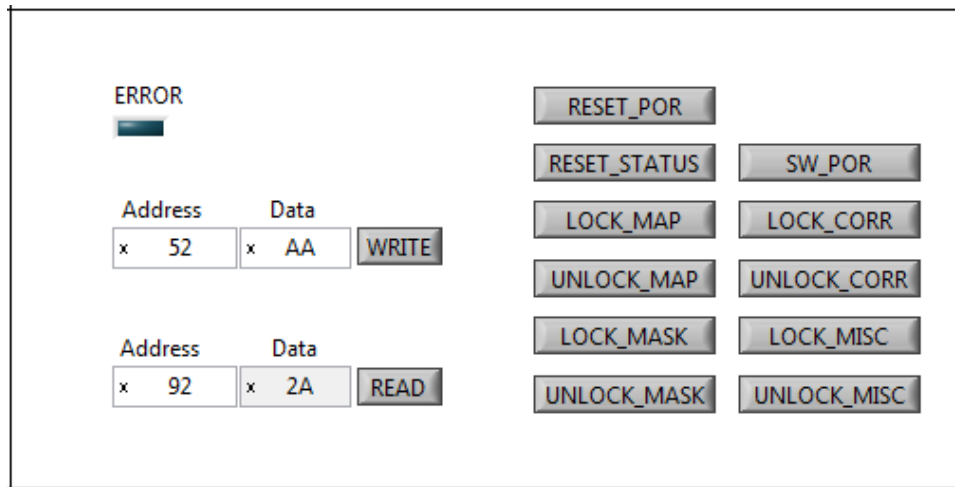

Figure 8. General Function IV

5.2 Advanced Commands

Figure 9 shows the advanced command functions. Users can write command sequences in the *Codes to Send* field. Users must follow the specific format when inputting the commands. The standard format for comments is *// comments* which is optional. The GUI identifies the *//* symbol and ignores the content following this symbol. The text following the symbol can be in either uppercase or lowercase. The delay function is only used for general delay as the delay time does not contain the software operate delay.

```
Address Data // comments
0x61 0x69 // power on reset
0x62 0x66
PWM(1,2,50) //PWM(Channel,Index,DutyCycle)
Delay 100 // Delay N, delay N ms
0x52 0x00 //Turn on CH0-CH5
0x53 0x00 //Turn on CH6-CH11
0x46 0xff //CH0 Dot Correction value = 255
.....
```

For the PWM command, the channel value should range from 0 to 2. A value of 0 corresponds with PWM0, a value of 1 corresponds with PWM1, and a value of 2 corresponds with PWM2. The index value should range from 0 to 9. This value corresponds with a frequency from 100 Hz to 100 kHz. Table 5 lists the relationship between the channel and PWM control. Table 6 lists the relationship between the index value and frequency.

Table 5. Channel and PWM Control

CHANNEL	0	1	2
PWM CONTROL	PWM0	PWM1	PWM2

Table 6. Index and Frequency

INDEX	0	1	2	3	4	5	6	7	8	9
FREQUENCY	100 Hz	200 Hz	500 Hz	1 kHz	2 kHz	5 kHz	10 kHz	20 kHz	50 kHz	100 kHz

The GUI can distinguish read commands from write commands. When the command is a read command, the read-back data is displayed in the *Codes Received* field.

Selecting the *Loop the Codes* box sends the codes repeatedly. The *Binary to Hex to Hexadecimal to Decimal Converter* can help users easily convert the data scale.

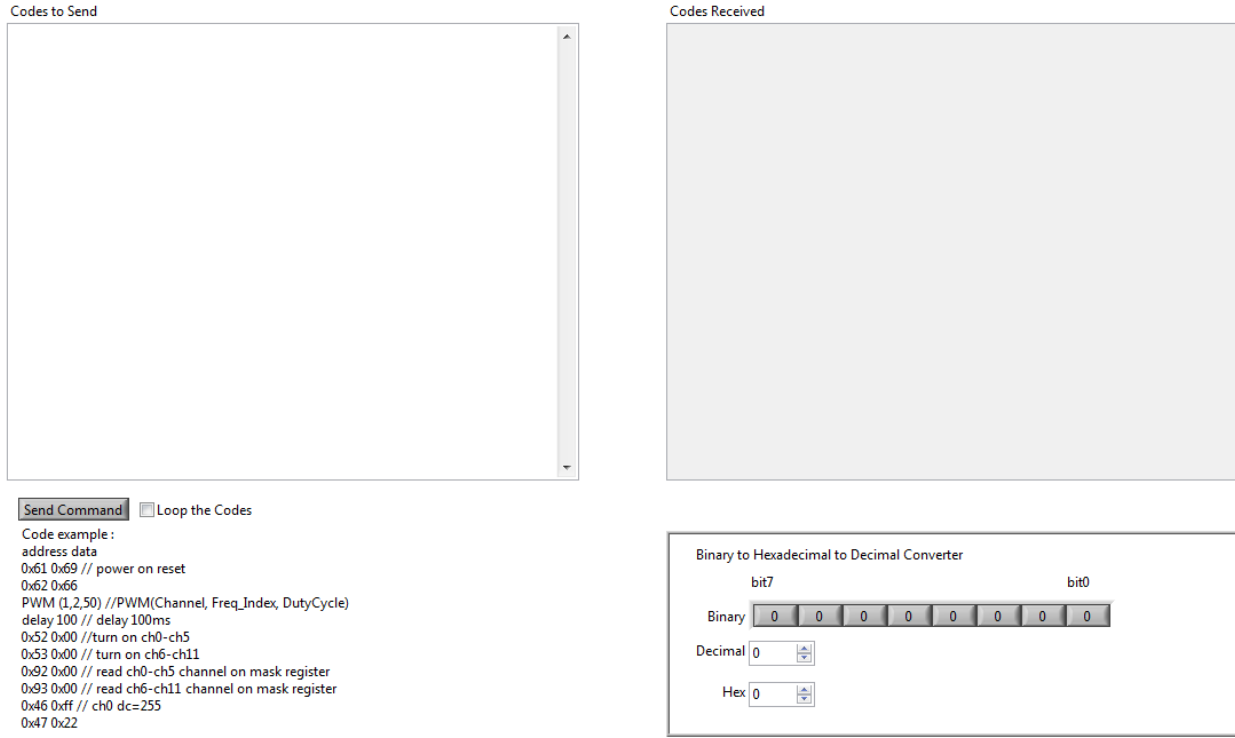
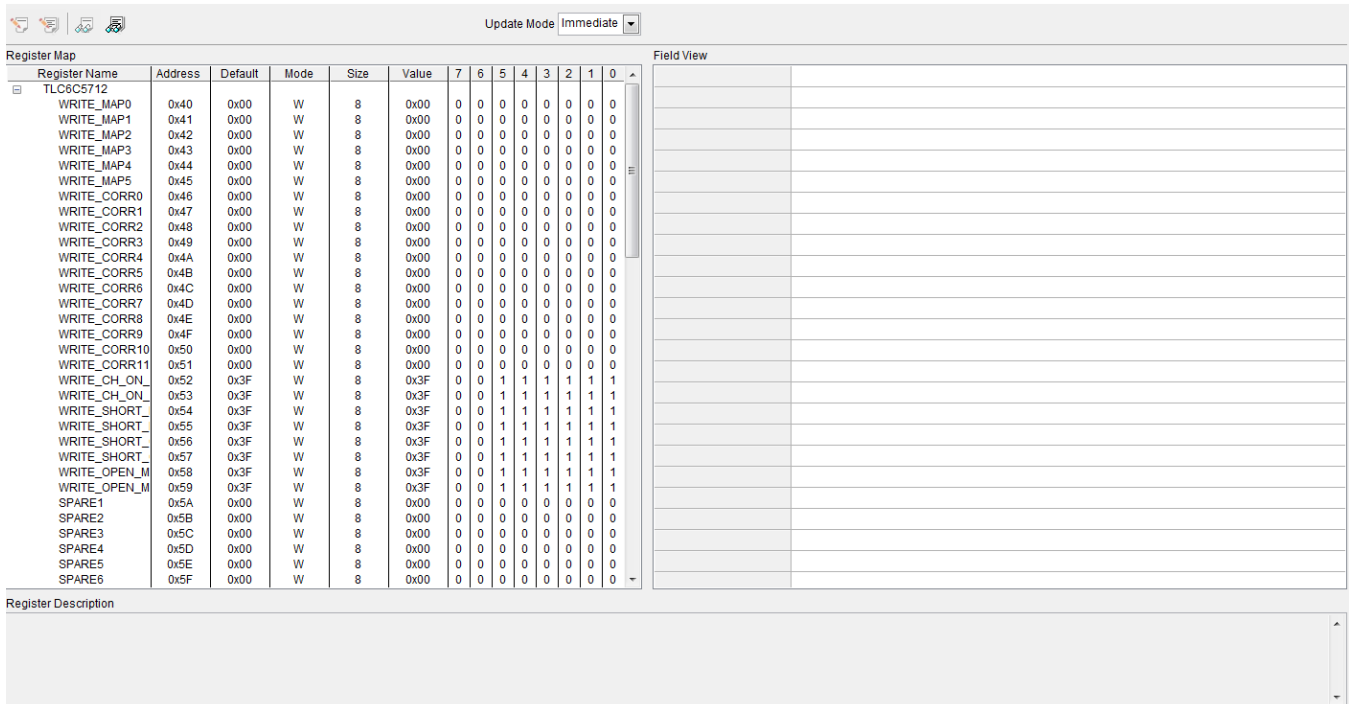

Figure 9. Advanced Commands

5.3 Register Map

In the low-level configuration, users can change the register bits by directly clicking the bit value. If the immediate update mode is selected, the register value is updated immediately when the value is changed. If manual update mode is selected, the register value is not updated unless the *Write Selected* or *Write Modified* button is clicked.



The screenshot shows the Register Map GUI for the TLC6C5712 device. At the top, there is an 'Update Mode' dropdown menu set to 'Immediate'. Below this is a table of registers. The table has columns for Register Name, Address, Default, Mode, Size, Value, and bit fields 7, 6, 5, 4, 3, 2, 1, 0. The registers listed include WRITE_MAP0 through WRITE_MAP5, WRITE_CORR0 through WRITE_CORR11, WRITE_CH_ON_ through WRITE_CH_ON_5, WRITE_SHORT_ through WRITE_SHORT_5, WRITE_OPEN_M_ through WRITE_OPEN_M_5, and SPARE1 through SPARE6. The 'Value' column shows the current value of each register, and the bit fields show the individual bit values. To the right of the table is a 'Field View' pane. Below the table is a 'Register Description' section.

Register Name	Address	Default	Mode	Size	Value	7	6	5	4	3	2	1	0
TLC6C5712													
WRITE_MAP0	0x40	0x00	W	8	0x00	0	0	0	0	0	0	0	0
WRITE_MAP1	0x41	0x00	W	8	0x00	0	0	0	0	0	0	0	0
WRITE_MAP2	0x42	0x00	W	8	0x00	0	0	0	0	0	0	0	0
WRITE_MAP3	0x43	0x00	W	8	0x00	0	0	0	0	0	0	0	0
WRITE_MAP4	0x44	0x00	W	8	0x00	0	0	0	0	0	0	0	0
WRITE_MAP5	0x45	0x00	W	8	0x00	0	0	0	0	0	0	0	0
WRITE_CORR0	0x46	0x00	W	8	0x00	0	0	0	0	0	0	0	0
WRITE_CORR1	0x47	0x00	W	8	0x00	0	0	0	0	0	0	0	0
WRITE_CORR2	0x48	0x00	W	8	0x00	0	0	0	0	0	0	0	0
WRITE_CORR3	0x49	0x00	W	8	0x00	0	0	0	0	0	0	0	0
WRITE_CORR4	0x4A	0x00	W	8	0x00	0	0	0	0	0	0	0	0
WRITE_CORR5	0x4B	0x00	W	8	0x00	0	0	0	0	0	0	0	0
WRITE_CORR6	0x4C	0x00	W	8	0x00	0	0	0	0	0	0	0	0
WRITE_CORR7	0x4D	0x00	W	8	0x00	0	0	0	0	0	0	0	0
WRITE_CORR8	0x4E	0x00	W	8	0x00	0	0	0	0	0	0	0	0
WRITE_CORR9	0x4F	0x00	W	8	0x00	0	0	0	0	0	0	0	0
WRITE_CORR10	0x50	0x00	W	8	0x00	0	0	0	0	0	0	0	0
WRITE_CORR11	0x51	0x00	W	8	0x00	0	0	0	0	0	0	0	0
WRITE_CH_ON_0	0x52	0x3F	W	8	0x3F	0	0	1	1	1	1	1	1
WRITE_CH_ON_1	0x53	0x3F	W	8	0x3F	0	0	1	1	1	1	1	1
WRITE_SHORT_0	0x54	0x3F	W	8	0x3F	0	0	1	1	1	1	1	1
WRITE_SHORT_1	0x55	0x3F	W	8	0x3F	0	0	1	1	1	1	1	1
WRITE_SHORT_2	0x56	0x3F	W	8	0x3F	0	0	1	1	1	1	1	1
WRITE_SHORT_3	0x57	0x3F	W	8	0x3F	0	0	1	1	1	1	1	1
WRITE_SHORT_4	0x58	0x3F	W	8	0x3F	0	0	1	1	1	1	1	1
WRITE_SHORT_5	0x59	0x3F	W	8	0x3F	0	0	1	1	1	1	1	1
SPARE1	0x5A	0x00	W	8	0x00	0	0	0	0	0	0	0	0
SPARE2	0x5B	0x00	W	8	0x00	0	0	0	0	0	0	0	0
SPARE3	0x5C	0x00	W	8	0x00	0	0	0	0	0	0	0	0
SPARE4	0x5D	0x00	W	8	0x00	0	0	0	0	0	0	0	0
SPARE5	0x5E	0x00	W	8	0x00	0	0	0	0	0	0	0	0
SPARE6	0x5F	0x00	W	8	0x00	0	0	0	0	0	0	0	0

Figure 10. Register Map

Users can save the register configuration by clicking the *Saving Configuration* button. When opening the configuration file, all of the saved registers value are reloaded into the device.

6 Bill of Materials and Schematic

Table 7 lists the bill of materials (BOM) for the TLC6C5712EVM.

Table 7. TLC6C5712-Q1 BOM

DESIGNATOR	QUANTITY	VALUE	DESCRIPTION	PARTNUMBER	MANUFACTURER
C1, C5	2	4.7 μ F	Capacitor, ceramic 4.7 μ F, 16 V, \pm 10%, X5R, 0805	GRM21BR61C475KA88L	MuRata
C2, C6	2	0.1 μ F	Capacitor, ceramic 0.1 μ F, 16 V, \pm 5%, X7R, 0603	0603YC104JAT2A	AVX
C3, C7, C9, C10	4	4.7 μ F	Capacitor, ceramic 4.7 μ F, 16 V, \pm 10%, X5R, 0805	EMK212BJ475KG-T	Taiyo Yuden
C8	1	10 μ F	Capacitor, ceramic 10 μ F, 16 V, \pm 10%, X6S, 0805	C2012X6S1C106MT	TDK
D1, D2, D3, D4, D5, D6, D7, D8, D9, D10, D11, D12	12	White	LED, White, SMD	LW-E6SG	OSRAM
D13, D26	2	Red	LED, Red, SMD	LTST-C170KRKT	Lite-On
D14, D17, D20, D23	4	Red	LED, Red, SMD	LR-E6SF	OSRAM
D15, D18, D21, D24	4	Green	LED, Green, SMD	LT-E6SG	OSRAM
D16, D19, D22, D25	4	Blue	LED, Blue, SMD	LB-E6SG	OSRAM
J1	1		Connector, 15x2, 3A 300V STRT DIP, TH	XG4C-3031	Omron Electronic Components
J2	1		Receptacle, 0.65 mm, 5x1, Gold, R/A, SMT	10118192-0001LF	FCI
J3, J4, J5, J6, J7, J8, J9, J10, J11, J12, J13, J14, J15, J16, J17	15		Header, 100mil, 2x1, Gold, TH	TSW-102-07-G-S	Samtec
J18	1		Header, 100mil, 8x2, Gold, TH	TSW-108-07-G-D	Samtec
J19	1		Header, 100mil, 5x2, Gold, TH	TSW-105-07-G-D	Samtec
J20, J33	2		Header, 100mil, 6x1, Gold, TH	TSW-106-07-G-S	Samtec
J21, J22, J23, J24, J25, J26, J27, J28, J29, J30, J31, J32, J34, J35, J36, J37, J38, J39, J40, J41, J42, J43, J44, J45	24		Header, 100mil, 1pos, Gold, TH	TSW-101-07-G-S	Samtec
R1, R4	2	12.1 k Ω	Resistor, 12.1 k Ω , 1%, 0.1 W, 0603	CRCW060312K1FKEA	Vishay-Dale
R2, R5	2	1 k Ω	Resistor, 1 k Ω , 5%, 0.1 W, 0603	CRCW06031K00JNEA	Vishay-Dale
R3, R6	2	3.3 k Ω	Resistor, 3.3 k Ω , 5%, 0.1 W, 0603	CRCW06033K30JNEA	Vishay-Dale
R7, R8	2	0	Resistor, 0, 5%, 0.1 W, 0603	ERJ-3GEY0R00V	Panasonic
SH-J1, SH-J2, SH-J3, SH-J4, SH-J5, SH-J6, SH-J7, SH-J8, SH-J9, SH-J10, SH-J11, SH-J12, SH-J13, SH-J14, SH-J15	15	1x2	Shunt, 100mil, Gold plated, Black	969102-0000-DA	3M
TP1, TP2, TP3	3	Double	Terminal, Turret, TH, Double	1502-2	Keystone
TP4, TP5, TP6, TP7, TP8, TP9, TP10, TP11, TP12, TP13, TP14, TP15, TP16, TP17, TP18, TP19, TP20, TP21, TP22, TP23, TP24, TP25, TP26, TP27, TP28, TP29, TP30	27	White	Test Point, Miniature, White, TH	5002	Keystone
U1	1		Constant Current Sink LED Driver, PWP0028H	TLC6C5712QPWPRQ1	Texas Instruments

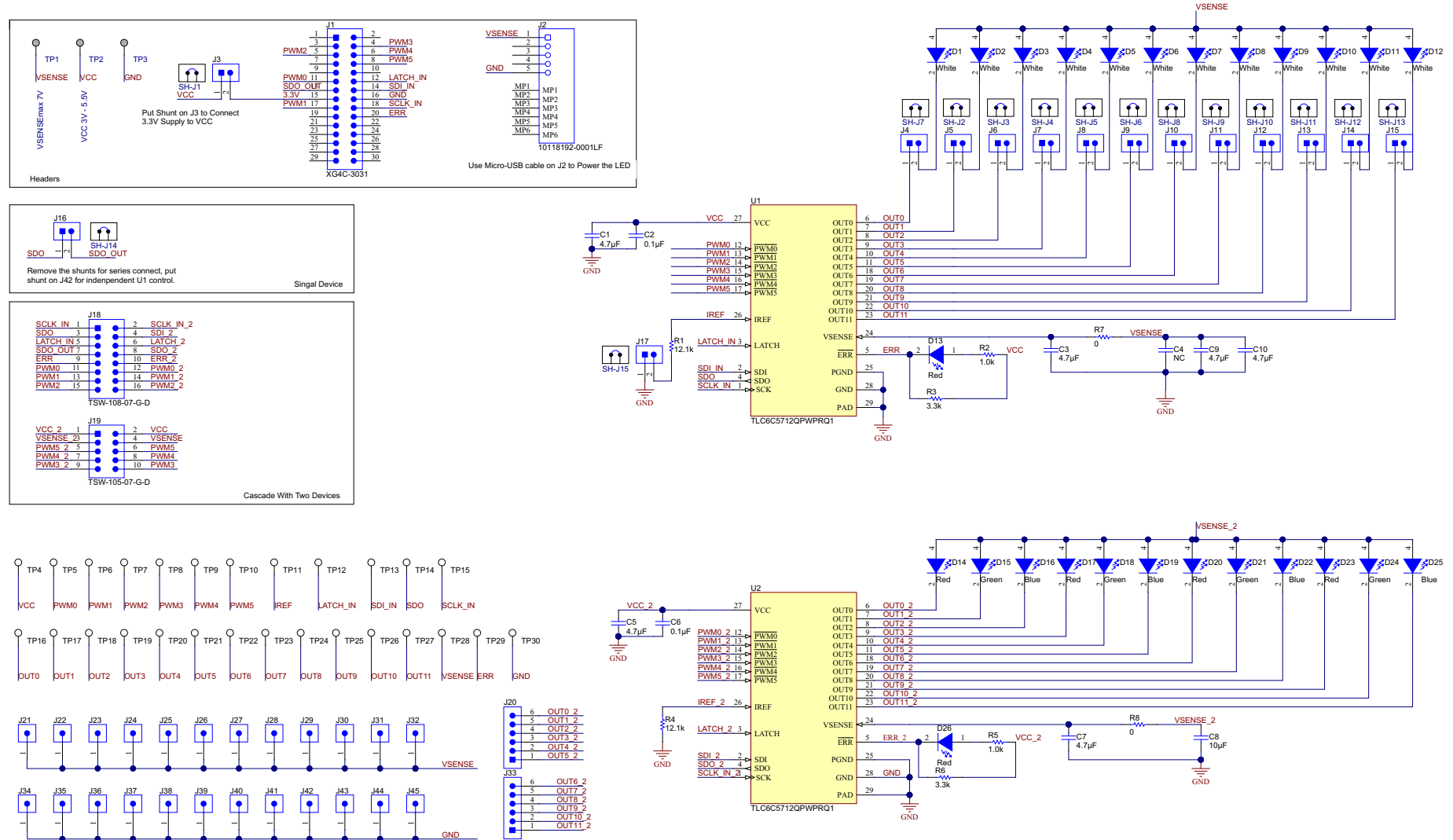

Figure 11. TLC6C5712EVM Schematic

Revision History

Changes from Original (January 2015) to A Revision	Page
---	-------------

- Changed the communication board from a LaunchPad to USB2ANY and updated connectors and layout 1
 - Added additional capacitors to VSENSE in the schematic..... 14
-

NOTE: Page numbers for previous revisions may differ from page numbers in the current version.

STANDARD TERMS AND CONDITIONS FOR EVALUATION MODULES

1. *Delivery:* TI delivers TI evaluation boards, kits, or modules, including any accompanying demonstration software, components, or documentation (collectively, an "EVM" or "EVMs") to the User ("User") in accordance with the terms and conditions set forth herein. Acceptance of the EVM is expressly subject to the following terms and conditions.
 - 1.1 EVMs are intended solely for product or software developers for use in a research and development setting to facilitate feasibility evaluation, experimentation, or scientific analysis of TI semiconductor products. EVMs have no direct function and are not finished products. EVMs shall not be directly or indirectly assembled as a part or subassembly in any finished product. For clarification, any software or software tools provided with the EVM ("Software") shall not be subject to the terms and conditions set forth herein but rather shall be subject to the applicable terms and conditions that accompany such Software
 - 1.2 EVMs are not intended for consumer or household use. EVMs may not be sold, sublicensed, leased, rented, loaned, assigned, or otherwise distributed for commercial purposes by Users, in whole or in part, or used in any finished product or production system.
2. *Limited Warranty and Related Remedies/Disclaimers:*
 - 2.1 These terms and conditions do not apply to Software. The warranty, if any, for Software is covered in the applicable Software License Agreement.
 - 2.2 TI warrants that the TI EVM will conform to TI's published specifications for ninety (90) days after the date TI delivers such EVM to User. Notwithstanding the foregoing, TI shall not be liable for any defects that are caused by neglect, misuse or mistreatment by an entity other than TI, including improper installation or testing, or for any EVMs that have been altered or modified in any way by an entity other than TI. Moreover, TI shall not be liable for any defects that result from User's design, specifications or instructions for such EVMs. Testing and other quality control techniques are used to the extent TI deems necessary or as mandated by government requirements. TI does not test all parameters of each EVM.
 - 2.3 If any EVM fails to conform to the warranty set forth above, TI's sole liability shall be at its option to repair or replace such EVM, or credit User's account for such EVM. TI's liability under this warranty shall be limited to EVMs that are returned during the warranty period to the address designated by TI and that are determined by TI not to conform to such warranty. If TI elects to repair or replace such EVM, TI shall have a reasonable time to repair such EVM or provide replacements. Repaired EVMs shall be warranted for the remainder of the original warranty period. Replaced EVMs shall be warranted for a new full ninety (90) day warranty period.
3. *Regulatory Notices:*
 - 3.1 *United States*
 - 3.1.1 *Notice applicable to EVMs not FCC-Approved:*

This kit is designed to allow product developers to evaluate electronic components, circuitry, or software associated with the kit to determine whether to incorporate such items in a finished product and software developers to write software applications for use with the end product. This kit is not a finished product and when assembled may not be resold or otherwise marketed unless all required FCC equipment authorizations are first obtained. Operation is subject to the condition that this product not cause harmful interference to licensed radio stations and that this product accept harmful interference. Unless the assembled kit is designed to operate under part 15, part 18 or part 95 of this chapter, the operator of the kit must operate under the authority of an FCC license holder or must secure an experimental authorization under part 5 of this chapter.
 - 3.1.2 *For EVMs annotated as FCC – FEDERAL COMMUNICATIONS COMMISSION Part 15 Compliant:*

CAUTION

This device complies with part 15 of the FCC Rules. Operation is subject to the following two conditions: (1) This device may not cause harmful interference, and (2) this device must accept any interference received, including interference that may cause undesired operation.

Changes or modifications not expressly approved by the party responsible for compliance could void the user's authority to operate the equipment.

FCC Interference Statement for Class A EVM devices

NOTE: This equipment has been tested and found to comply with the limits for a Class A digital device, pursuant to part 15 of the FCC Rules. These limits are designed to provide reasonable protection against harmful interference when the equipment is operated in a commercial environment. This equipment generates, uses, and can radiate radio frequency energy and, if not installed and used in accordance with the instruction manual, may cause harmful interference to radio communications. Operation of this equipment in a residential area is likely to cause harmful interference in which case the user will be required to correct the interference at his own expense.

FCC Interference Statement for Class B EVM devices

NOTE: This equipment has been tested and found to comply with the limits for a Class B digital device, pursuant to part 15 of the FCC Rules. These limits are designed to provide reasonable protection against harmful interference in a residential installation. This equipment generates, uses and can radiate radio frequency energy and, if not installed and used in accordance with the instructions, may cause harmful interference to radio communications. However, there is no guarantee that interference will not occur in a particular installation. If this equipment does cause harmful interference to radio or television reception, which can be determined by turning the equipment off and on, the user is encouraged to try to correct the interference by one or more of the following measures:

- Reorient or relocate the receiving antenna.
- Increase the separation between the equipment and receiver.
- Connect the equipment into an outlet on a circuit different from that to which the receiver is connected.
- Consult the dealer or an experienced radio/TV technician for help.

3.2 Canada

3.2.1 For EVMs issued with an Industry Canada Certificate of Conformance to RSS-210

Concerning EVMs Including Radio Transmitters:

This device complies with Industry Canada license-exempt RSS standard(s). Operation is subject to the following two conditions: (1) this device may not cause interference, and (2) this device must accept any interference, including interference that may cause undesired operation of the device.

Concernant les EVMs avec appareils radio:

Le présent appareil est conforme aux CNR d'Industrie Canada applicables aux appareils radio exempts de licence. L'exploitation est autorisée aux deux conditions suivantes: (1) l'appareil ne doit pas produire de brouillage, et (2) l'utilisateur de l'appareil doit accepter tout brouillage radioélectrique subi, même si le brouillage est susceptible d'en compromettre le fonctionnement.

Concerning EVMs Including Detachable Antennas:

Under Industry Canada regulations, this radio transmitter may only operate using an antenna of a type and maximum (or lesser) gain approved for the transmitter by Industry Canada. To reduce potential radio interference to other users, the antenna type and its gain should be so chosen that the equivalent isotropically radiated power (e.i.r.p.) is not more than that necessary for successful communication. This radio transmitter has been approved by Industry Canada to operate with the antenna types listed in the user guide with the maximum permissible gain and required antenna impedance for each antenna type indicated. Antenna types not included in this list, having a gain greater than the maximum gain indicated for that type, are strictly prohibited for use with this device.

Concernant les EVMs avec antennes détachables

Conformément à la réglementation d'Industrie Canada, le présent émetteur radio peut fonctionner avec une antenne d'un type et d'un gain maximal (ou inférieur) approuvé pour l'émetteur par Industrie Canada. Dans le but de réduire les risques de brouillage radioélectrique à l'intention des autres utilisateurs, il faut choisir le type d'antenne et son gain de sorte que la puissance isotrope rayonnée équivalente (p.i.r.e.) ne dépasse pas l'intensité nécessaire à l'établissement d'une communication satisfaisante. Le présent émetteur radio a été approuvé par Industrie Canada pour fonctionner avec les types d'antenne énumérés dans le manuel d'usage et ayant un gain admissible maximal et l'impédance requise pour chaque type d'antenne. Les types d'antenne non inclus dans cette liste, ou dont le gain est supérieur au gain maximal indiqué, sont strictement interdits pour l'exploitation de l'émetteur.

3.3 Japan

3.3.1 *Notice for EVMs delivered in Japan:* Please see http://www.tij.co.jp/lstds/ti_ja/general/eStore/notice_01.page 日本国内に輸入される評価用キット、ボードについては、次のところをご覧ください。
http://www.tij.co.jp/lstds/ti_ja/general/eStore/notice_01.page

3.3.2 *Notice for Users of EVMs Considered "Radio Frequency Products" in Japan:* EVMs entering Japan may not be certified by TI as conforming to Technical Regulations of Radio Law of Japan.

If User uses EVMs in Japan, not certified to Technical Regulations of Radio Law of Japan, User is required by Radio Law of Japan to follow the instructions below with respect to EVMs:

1. Use EVMs in a shielded room or any other test facility as defined in the notification #173 issued by Ministry of Internal Affairs and Communications on March 28, 2006, based on Sub-section 1.1 of Article 6 of the Ministry's Rule for Enforcement of Radio Law of Japan,
2. Use EVMs only after User obtains the license of Test Radio Station as provided in Radio Law of Japan with respect to EVMs, or
3. Use of EVMs only after User obtains the Technical Regulations Conformity Certification as provided in Radio Law of Japan with respect to EVMs. Also, do not transfer EVMs, unless User gives the same notice above to the transferee. Please note that if User does not follow the instructions above, User will be subject to penalties of Radio Law of Japan.

【無線電波を送信する製品の開発キットをお使いになる際の注意事項】 開発キットの中には技術基準適合証明を受けていないものがあります。技術適合証明を受けていないものご使用に際しては、電波法遵守のため、以下のいずれかの措置を取っていただく必要がありますのでご注意ください。

1. 電波法施行規則第6条第1項第1号に基づく平成18年3月28日総務省告示第173号で定められた電波暗室等の試験設備でご使用いただく。
2. 実験局の免許を取得後ご使用いただく。
3. 技術基準適合証明を取得後ご使用いただく。

なお、本製品は、上記の「ご使用にあたっての注意」を譲渡先、移転先に通知しない限り、譲渡、移転できないものとします。

上記を遵守頂けない場合は、電波法の罰則が適用される可能性があることをご留意ください。日本テキサス・インスツルメンツ株式会社
東京都新宿区西新宿 6 丁目 2 4 番 1 号
西新宿三井ビル

3.3.3 *Notice for EVMs for Power Line Communication:* Please see http://www.tij.co.jp/llds/ti_ja/general/eStore/notice_02.page
電力線搬送波通信についての開発キットをお使いになる際の注意事項については、次のところをご覧ください。http://www.tij.co.jp/llds/ti_ja/general/eStore/notice_02.page

4 *EVM Use Restrictions and Warnings:*

- 4.1 EVMS ARE NOT FOR USE IN FUNCTIONAL SAFETY AND/OR SAFETY CRITICAL EVALUATIONS, INCLUDING BUT NOT LIMITED TO EVALUATIONS OF LIFE SUPPORT APPLICATIONS.
- 4.2 User must read and apply the user guide and other available documentation provided by TI regarding the EVM prior to handling or using the EVM, including without limitation any warning or restriction notices. The notices contain important safety information related to, for example, temperatures and voltages.
- 4.3 *Safety-Related Warnings and Restrictions:*
 - 4.3.1 User shall operate the EVM within TI's recommended specifications and environmental considerations stated in the user guide, other available documentation provided by TI, and any other applicable requirements and employ reasonable and customary safeguards. Exceeding the specified performance ratings and specifications (including but not limited to input and output voltage, current, power, and environmental ranges) for the EVM may cause personal injury or death, or property damage. If there are questions concerning performance ratings and specifications, User should contact a TI field representative prior to connecting interface electronics including input power and intended loads. Any loads applied outside of the specified output range may also result in unintended and/or inaccurate operation and/or possible permanent damage to the EVM and/or interface electronics. Please consult the EVM user guide prior to connecting any load to the EVM output. If there is uncertainty as to the load specification, please contact a TI field representative. During normal operation, even with the inputs and outputs kept within the specified allowable ranges, some circuit components may have elevated case temperatures. These components include but are not limited to linear regulators, switching transistors, pass transistors, current sense resistors, and heat sinks, which can be identified using the information in the associated documentation. When working with the EVM, please be aware that the EVM may become very warm.
 - 4.3.2 EVMs are intended solely for use by technically qualified, professional electronics experts who are familiar with the dangers and application risks associated with handling electrical mechanical components, systems, and subsystems. User assumes all responsibility and liability for proper and safe handling and use of the EVM by User or its employees, affiliates, contractors or designees. User assumes all responsibility and liability to ensure that any interfaces (electronic and/or mechanical) between the EVM and any human body are designed with suitable isolation and means to safely limit accessible leakage currents to minimize the risk of electrical shock hazard. User assumes all responsibility and liability for any improper or unsafe handling or use of the EVM by User or its employees, affiliates, contractors or designees.
- 4.4 User assumes all responsibility and liability to determine whether the EVM is subject to any applicable international, federal, state, or local laws and regulations related to User's handling and use of the EVM and, if applicable, User assumes all responsibility and liability for compliance in all respects with such laws and regulations. User assumes all responsibility and liability for proper disposal and recycling of the EVM consistent with all applicable international, federal, state, and local requirements.

5. *Accuracy of Information:* To the extent TI provides information on the availability and function of EVMs, TI attempts to be as accurate as possible. However, TI does not warrant the accuracy of EVM descriptions, EVM availability or other information on its websites as accurate, complete, reliable, current, or error-free.

6. *Disclaimers:*

6.1 EXCEPT AS SET FORTH ABOVE, EVMS AND ANY WRITTEN DESIGN MATERIALS PROVIDED WITH THE EVM (AND THE DESIGN OF THE EVM ITSELF) ARE PROVIDED "AS IS" AND "WITH ALL FAULTS." TI DISCLAIMS ALL OTHER WARRANTIES, EXPRESS OR IMPLIED, REGARDING SUCH ITEMS, INCLUDING BUT NOT LIMITED TO ANY IMPLIED WARRANTIES OF MERCHANTABILITY OR FITNESS FOR A PARTICULAR PURPOSE OR NON-INFRINGEMENT OF ANY THIRD PARTY PATENTS, COPYRIGHTS, TRADE SECRETS OR OTHER INTELLECTUAL PROPERTY RIGHTS.

6.2 EXCEPT FOR THE LIMITED RIGHT TO USE THE EVM SET FORTH HEREIN, NOTHING IN THESE TERMS AND CONDITIONS SHALL BE CONSTRUED AS GRANTING OR CONFERRING ANY RIGHTS BY LICENSE, PATENT, OR ANY OTHER INDUSTRIAL OR INTELLECTUAL PROPERTY RIGHT OF TI, ITS SUPPLIERS/LICENSORS OR ANY OTHER THIRD PARTY, TO USE THE EVM IN ANY FINISHED END-USER OR READY-TO-USE FINAL PRODUCT, OR FOR ANY INVENTION, DISCOVERY OR IMPROVEMENT MADE, CONCEIVED OR ACQUIRED PRIOR TO OR AFTER DELIVERY OF THE EVM.

7. *USER'S INDEMNITY OBLIGATIONS AND REPRESENTATIONS.* USER WILL DEFEND, INDEMNIFY AND HOLD TI, ITS LICENSORS AND THEIR REPRESENTATIVES HARMLESS FROM AND AGAINST ANY AND ALL CLAIMS, DAMAGES, LOSSES, EXPENSES, COSTS AND LIABILITIES (COLLECTIVELY, "CLAIMS") ARISING OUT OF OR IN CONNECTION WITH ANY HANDLING OR USE OF THE EVM THAT IS NOT IN ACCORDANCE WITH THESE TERMS AND CONDITIONS. THIS OBLIGATION SHALL APPLY WHETHER CLAIMS ARISE UNDER STATUTE, REGULATION, OR THE LAW OF TORT, CONTRACT OR ANY OTHER LEGAL THEORY, AND EVEN IF THE EVM FAILS TO PERFORM AS DESCRIBED OR EXPECTED.

8. *Limitations on Damages and Liability:*

8.1 *General Limitations.* IN NO EVENT SHALL TI BE LIABLE FOR ANY SPECIAL, COLLATERAL, INDIRECT, PUNITIVE, INCIDENTAL, CONSEQUENTIAL, OR EXEMPLARY DAMAGES IN CONNECTION WITH OR ARISING OUT OF THESE TERMS AND CONDITIONS OR THE USE OF THE EVMS PROVIDED HEREUNDER, REGARDLESS OF WHETHER TI HAS BEEN ADVISED OF THE POSSIBILITY OF SUCH DAMAGES. EXCLUDED DAMAGES INCLUDE, BUT ARE NOT LIMITED TO, COST OF REMOVAL OR REINSTALLATION, ANCILLARY COSTS TO THE PROCUREMENT OF SUBSTITUTE GOODS OR SERVICES, RETESTING, OUTSIDE COMPUTER TIME, LABOR COSTS, LOSS OF GOODWILL, LOSS OF PROFITS, LOSS OF SAVINGS, LOSS OF USE, LOSS OF DATA, OR BUSINESS INTERRUPTION. NO CLAIM, SUIT OR ACTION SHALL BE BROUGHT AGAINST TI MORE THAN ONE YEAR AFTER THE RELATED CAUSE OF ACTION HAS OCCURRED.

8.2 *Specific Limitations.* IN NO EVENT SHALL TI'S AGGREGATE LIABILITY FROM ANY WARRANTY OR OTHER OBLIGATION ARISING OUT OF OR IN CONNECTION WITH THESE TERMS AND CONDITIONS, OR ANY USE OF ANY TI EVM PROVIDED HEREUNDER, EXCEED THE TOTAL AMOUNT PAID TO TI FOR THE PARTICULAR UNITS SOLD UNDER THESE TERMS AND CONDITIONS WITH RESPECT TO WHICH LOSSES OR DAMAGES ARE CLAIMED. THE EXISTENCE OF MORE THAN ONE CLAIM AGAINST THE PARTICULAR UNITS SOLD TO USER UNDER THESE TERMS AND CONDITIONS SHALL NOT ENLARGE OR EXTEND THIS LIMIT.

9. *Return Policy.* Except as otherwise provided, TI does not offer any refunds, returns, or exchanges. Furthermore, no return of EVM(s) will be accepted if the package has been opened and no return of the EVM(s) will be accepted if they are damaged or otherwise not in a resalable condition. If User feels it has been incorrectly charged for the EVM(s) it ordered or that delivery violates the applicable order, User should contact TI. All refunds will be made in full within thirty (30) working days from the return of the components(s), excluding any postage or packaging costs.

10. *Governing Law:* These terms and conditions shall be governed by and interpreted in accordance with the laws of the State of Texas, without reference to conflict-of-laws principles. User agrees that non-exclusive jurisdiction for any dispute arising out of or relating to these terms and conditions lies within courts located in the State of Texas and consents to venue in Dallas County, Texas. Notwithstanding the foregoing, any judgment may be enforced in any United States or foreign court, and TI may seek injunctive relief in any United States or foreign court.

IMPORTANT NOTICE AND DISCLAIMER

TI PROVIDES TECHNICAL AND RELIABILITY DATA (INCLUDING DATASHEETS), DESIGN RESOURCES (INCLUDING REFERENCE DESIGNS), APPLICATION OR OTHER DESIGN ADVICE, WEB TOOLS, SAFETY INFORMATION, AND OTHER RESOURCES "AS IS" AND WITH ALL FAULTS, AND DISCLAIMS ALL WARRANTIES, EXPRESS AND IMPLIED, INCLUDING WITHOUT LIMITATION ANY IMPLIED WARRANTIES OF MERCHANTABILITY, FITNESS FOR A PARTICULAR PURPOSE OR NON-INFRINGEMENT OF THIRD PARTY INTELLECTUAL PROPERTY RIGHTS.

These resources are intended for skilled developers designing with TI products. You are solely responsible for (1) selecting the appropriate TI products for your application, (2) designing, validating and testing your application, and (3) ensuring your application meets applicable standards, and any other safety, security, regulatory or other requirements.

These resources are subject to change without notice. TI grants you permission to use these resources only for development of an application that uses the TI products described in the resource. Other reproduction and display of these resources is prohibited. No license is granted to any other TI intellectual property right or to any third party intellectual property right. TI disclaims responsibility for, and you fully indemnify TI and its representatives against any claims, damages, costs, losses, and liabilities arising out of your use of these resources.

TI's products are provided subject to [TI's Terms of Sale](#), [TI's General Quality Guidelines](#), or other applicable terms available either on [ti.com](#) or provided in conjunction with such TI products. TI's provision of these resources does not expand or otherwise alter TI's applicable warranties or warranty disclaimers for TI products. Unless TI explicitly designates a product as custom or customer-specified, TI products are standard, catalog, general purpose devices.

TI objects to and rejects any additional or different terms you may propose.

Copyright © 2026, Texas Instruments Incorporated

Last updated 10/2025