

EVM User's Guide: TXE81XXEVM

TXE81XX Evaluation Module



Description

The TXE81XXEVM allows the evaluation of the TXE81XX family of SPI I/O expanders. This EVM supports TXE8116 and TXE8124 (16-bit & 24-bit respectively) in the leaded package type DGS(24 and 32). The EVM provides access to many test points and headers to accompany the extensive amount of I/O's provided by each expander. There are a mix of male and female header types which allow for easy shunt connections.

Get Started

1. Order the TXE81XXEVM.
2. Download the latest USB2ANY firmware.
3. Download the latest version of the GUI.

Features

- USB powered 3.3V
- Option for external power
- ICC current measurement header (for current consumption measurements)

- Various male and female connection headers + test points for quick testing
- On-board USB2ANY for minimal SPI driver setup
- On-board USB2ANY works with online GUI in the cloud or download to desktop
- LED's for visual feedback (port, /RESET, /INT)
- LED enable/disable header
- Additional test points and headers for SPI connections (SDI/SDO/SCLK/CS)
- Can be used with external drivers such as MSPM0, TP Aardvark, TP Cheetah, TP Promira, Arduino, ESP32
- Manual reset toggle switch to reset the SPI to I/O expander
- Daisy chain capable between multiple TXE81XXEVM's

Applications

- Extending the GPIO's of an MCU
- Sensor Control
- Driving LED's and arrays
- Keypad / Matrix Handling

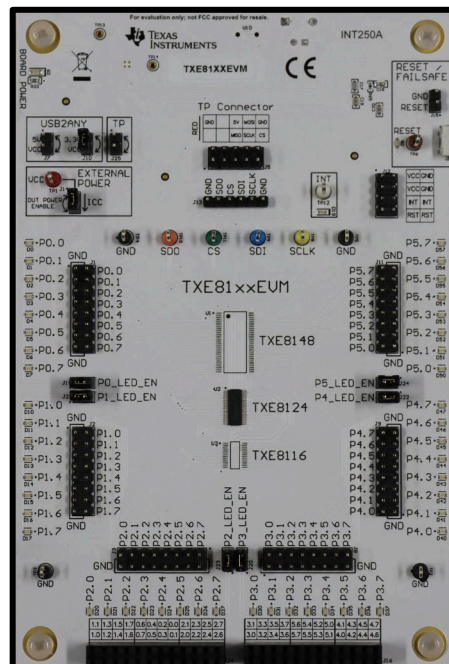

TXE81XXEVM

1 Evaluation Module Overview

1.1 Introduction

This guide helps to evaluate TI's family of serial peripheral interface (SPI) to general-purpose input/output (GPIO) expanders, which includes TXE8116 and TXE8124 (16 bit / 24 bit). The information in this guide provides the details for flashing the on-board USB2ANY circuit, online TXE GUI access, utilizing the MSPM0 as an external SPI driver, and information for using a third party SPI driver with common platforms such as ESP32, Arduino, Total Phase SPI drivers, and so forth.

The TXE81XXEVM evaluation kit has multiple test points, male and female headers, and LED indicators to allow for intuitive bench testing of TXE81XX. The board is designed for ease of access to each GPIO, as well as many connections for the use of an oscilloscope. The board can be powered by an external power supply or by a USB connection from a standard PC.

1.2 Kit Contents

- TXE81XXEVM
- Mini USB Cable

1.3 Specification

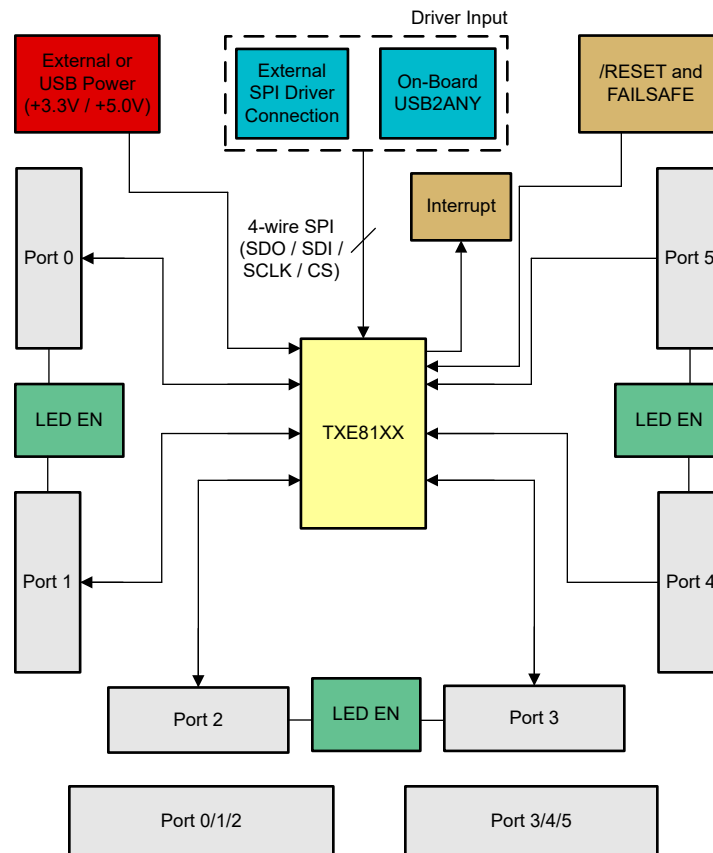

Figure 1-1. Simplified Block Diagram

1.4 Device Information

TXE81XX family includes 16-bit and 24-bit I/O expanders driven by the SPI protocol. The IC's are AEC-Q100 qualified for automotive applications, up to 10MHz SPI SCLK frequency, active-low reset input, configurable fail-safe I/O registers for redundancy, open-drain active-low interrupt pin, internal pull-up/pull-down resistors, open-drain vs. push-pull output, programmable drive strength, latching-bus-holding inputs, and maskable interrupts. The leaded package type is used on this EVM for solderability purposes.

2 Hardware

2.1 Additional Images

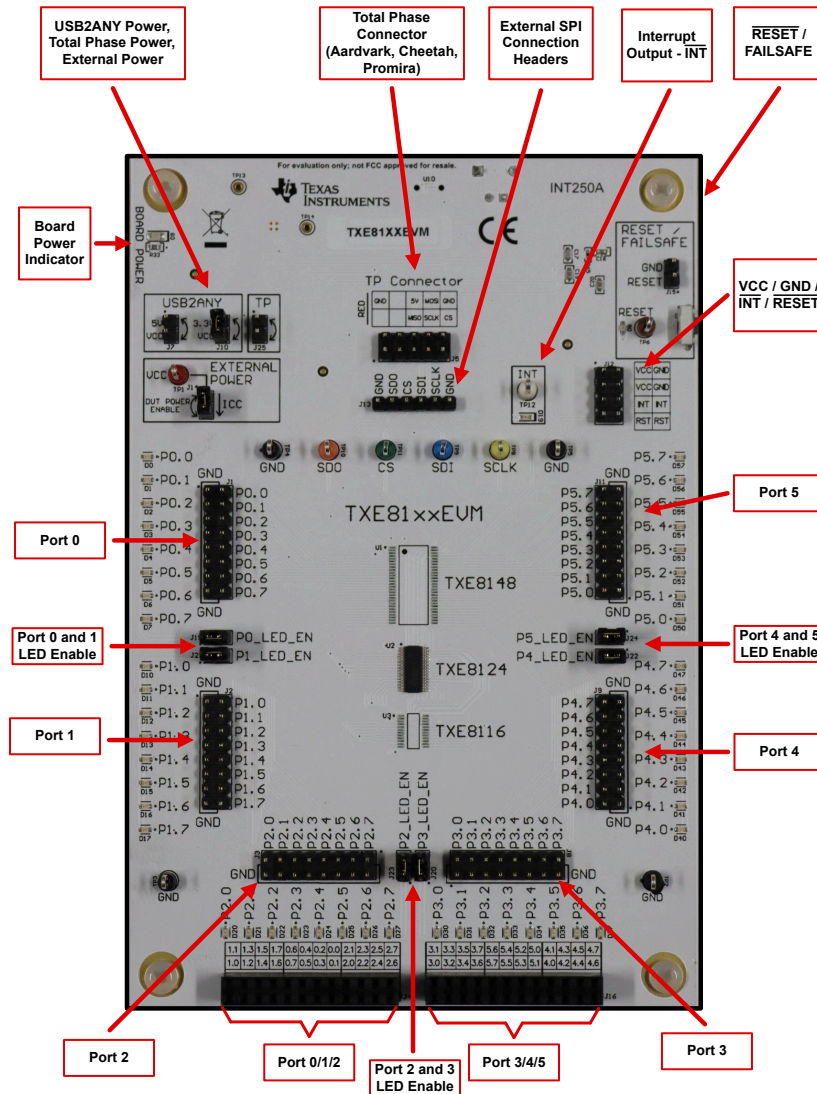

Figure 2-1. Top Side of Board

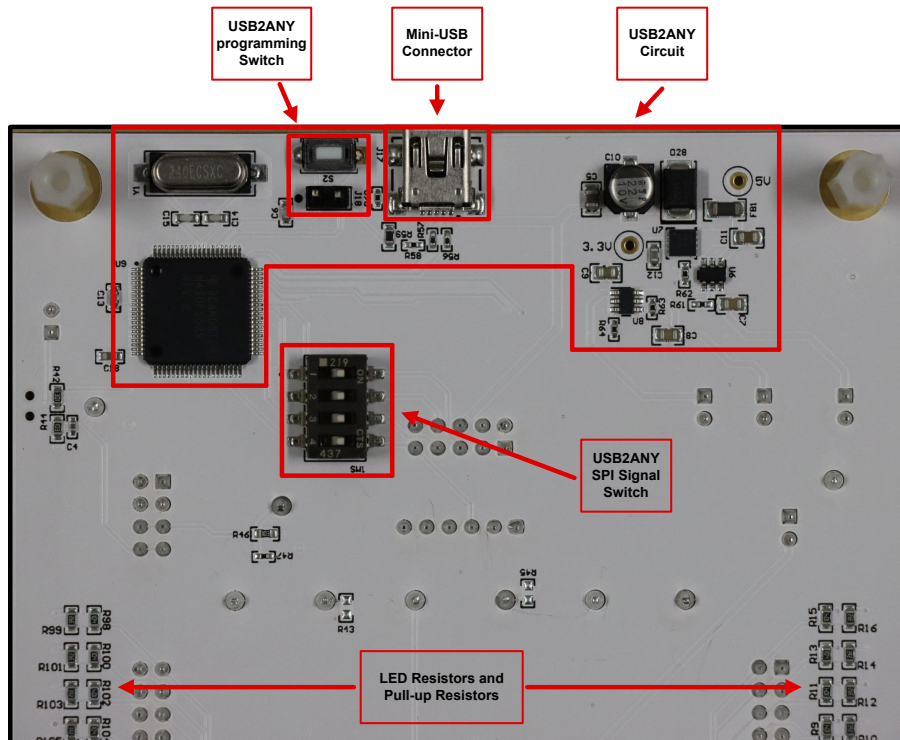

Figure 2-2. Bottom Side of Board

2.2 Power Requirements

TXE81XXEVM has a few different options for powering the board. When the TXE81XX is powered, the "BOARD POWER" indicator D9 lights up. This means that power is being applied to the board. This does not necessarily mean that the DUT is powered at this time. To confirm power at the DUT, J14 must be shorted. The board supports 3.3V USB power through the USB2ANY Explorer GUI. The Total Phase or "TP" jumper J25 connects the power from Total Phase products listed: SPI Aardvark, Cheetah SPI, Promira Serial Platform. TXE81XXEVM permits external power connection through a separate power source.

When jumping power connections, see guidelines in [Table 2-1](#). Only 1 power option can be shorted to VCC at a single time. This includes 3.3V USB2ANY, 5V USB2ANY, TP power, or and external power supply connection at the test point TP1.

Note

Only 1 jumper option can be enabled at a single time. 5V, 3.3V, or TP can be selected individually, never together. This also includes power coming from an external source on the VCC test point (TP1). Once the power connection is selected, short the power header J14 to enable power to the DUT.

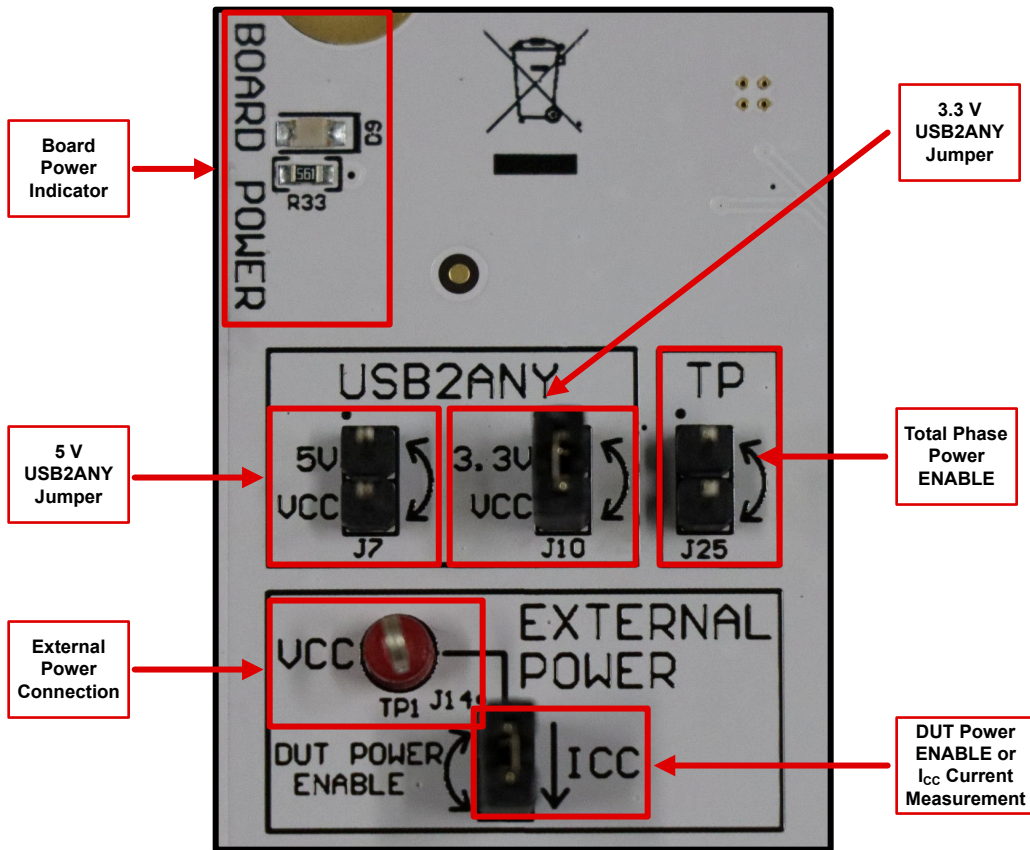

Figure 2-3. Power Options

Table 2-1. Power Jumper Connections

Designator	Description
J7	USB2ANY 5V to V_{CC} connection
J10	USB2ANY 3.3V to V_{CC} Connection
J25	Total Phase Power Connection (+ 3.3V)
J14	Connects power from USB2ANY, Total Phase product, or external power connection to the DUT. This header can be used to measure current flow to the TXE81xx.

2.3 Setup and Connecting the EVM

The TXE81XXEVM comes with a mini-usb cable. Connect the TXE81XXEVM to a computer or laptop through a USB 3.0 port.

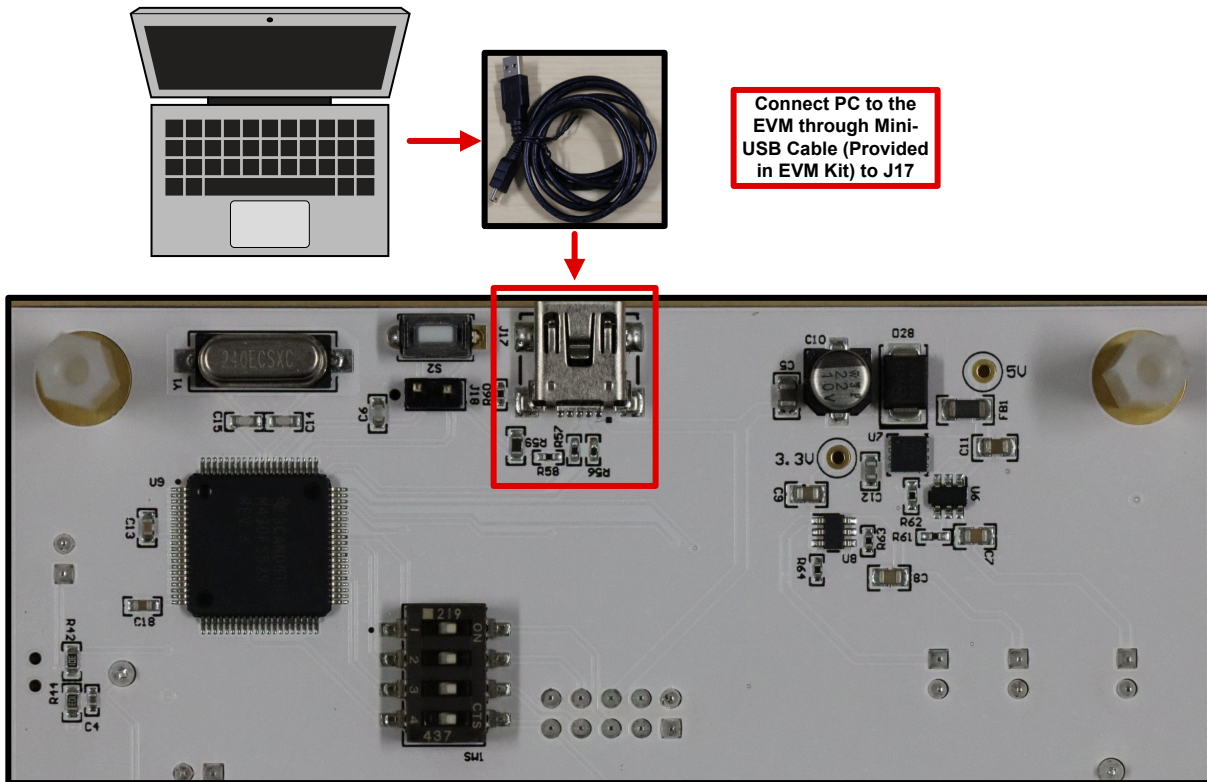

Figure 2-4. Connect to the TXE81XXEVM via Mini-USB to J17 on the Back of the EVM

Once connected, follow the steps in [Section 3.2.1](#).

2.4 Header and Jumper Information

The following section is a complete summary of the various headers and jumper connections on the TXE81XXEVM.

Figure 2-5 describes LED enable jumpers. If the header is left un-populated, the LED's for the specific port are disabled.

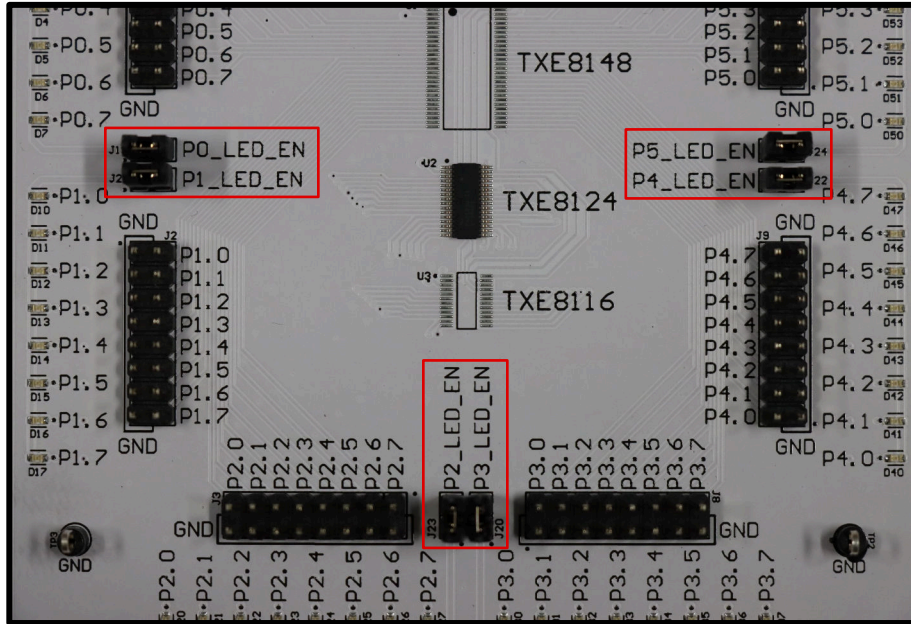

Figure 2-5. Port 0 - Port 5 LED Enable Jumper Locations

Table 2-2. LED Enables

Designator	Port #
J19	Port 0 - LED Enable
J21	Port 1- LED Enable
J23	Port 2- LED Enable
J20	Port 3- LED Enable
J22	Port 4- LED Enable
J24	Port 5- LED Enable

Header J18 is used for programming the on-board USB2ANY circuit. For more details, see [Figure 2-6](#).

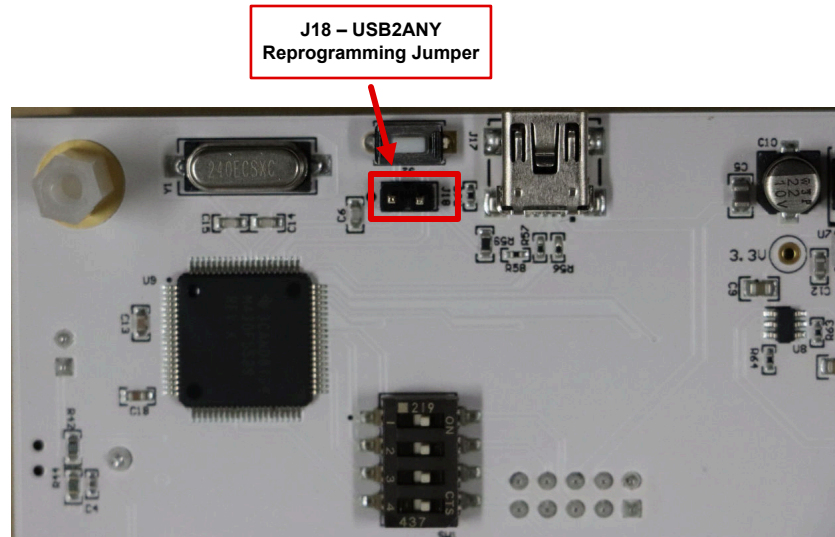

Figure 2-6. USB2ANY Circuit Programming Jumper (J18)

2.5 Push Buttons and Switches

This section covers the various button and switch locations on the EVM.

SW1 connects the USB2ANY driver SPI signals to the SDO / SDI / SCLK / CS on the EVM. The "ON" position for this switch is when the switch is in the right-most position.

When a Total Phase product or external SPI driver is connected, disable the 4 SPI signals on SW1.

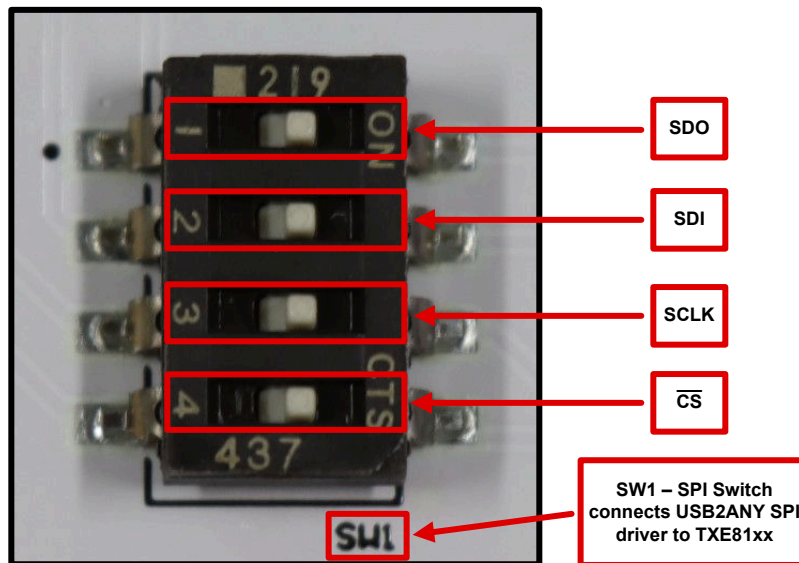

Figure 2-7. SPI Switch SW1

Push button S2 puts the USB2ANY circuit into programming mode when depressed while the TXE81XXEVM is being plugged in. This is an alternative method to programming the USB2ANY circuit. The easier method is to short J18 instead. If not programming the USB2ANY circuit, there is no further use case for S2.

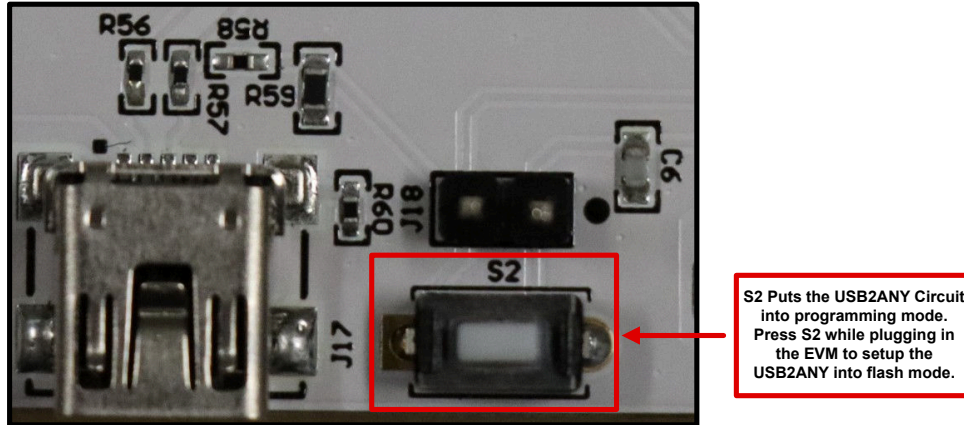

Figure 2-8. Programming Button S2

S1 is a side button used for manually resetting the TXE81XX. When S1 is pressed, it shorts RESET of the TXE81XX to GND. A pull-up resistor is used to bring the voltage on RESET back up to V_{CC} .

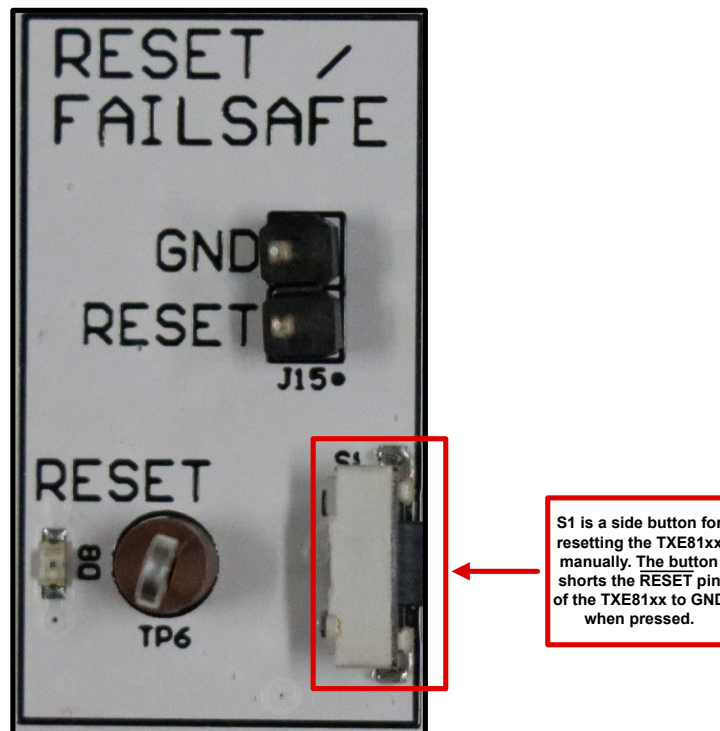

Figure 2-9. RESET Button S1

2.6 Driver Interfaces

The TXE81XXEVM can operate with SPI clock signals of up to 10MHz when V_{CC} is between 3.3V to 5.5V, or 5MHz when V_{CC} is between 1.65V to 5.5V.

The TXE81XXEVM has several options for SPI driver interfaces. The on-board USB2ANY circuit located on the bottom of the EVM, allows for quick access to a SPI driver that can communicate to the TXE81XX up to 8 MHz SPI.

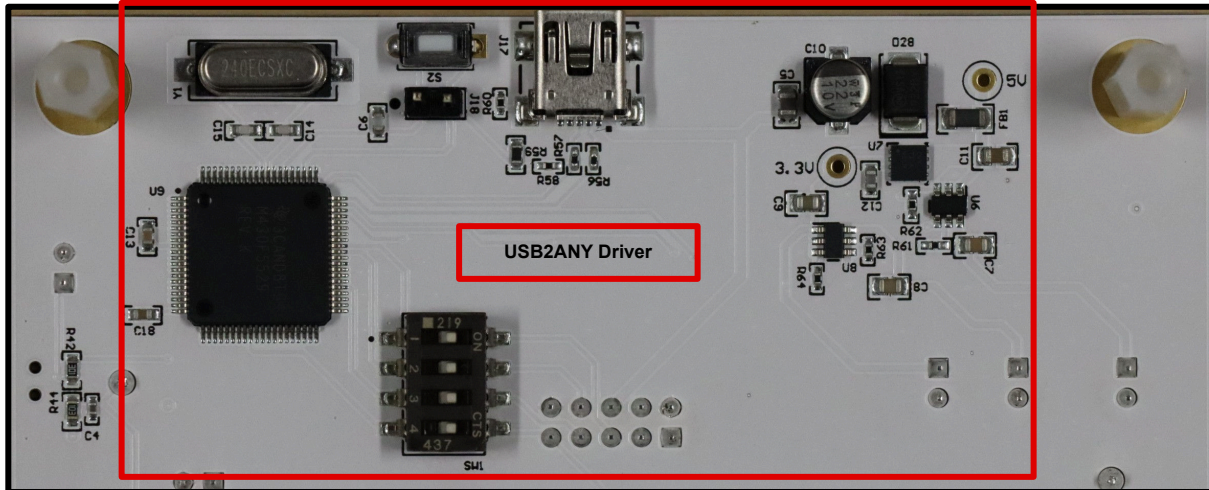

Figure 2-10. USB2ANY Driver

The EVM can be paired with an external MCU such as MSPM0 for programming the TXE81XX on the EVM. for more information, see [How to Program TXE81XX SPI I/O Expander Family](#).

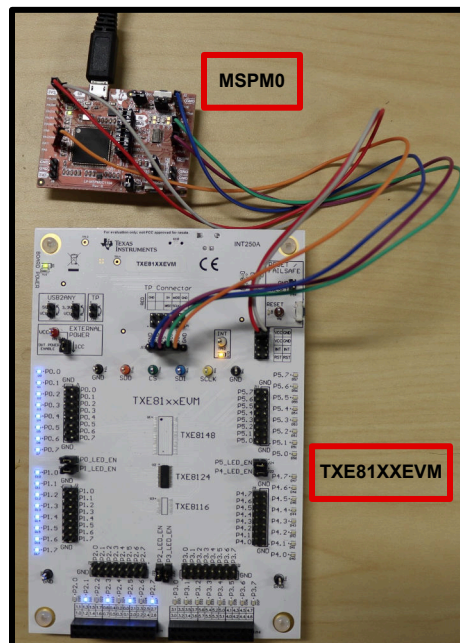

Figure 2-11. Using MSPM0 to Program the Device

The EVM also has a connector specific to third party tools such as [Total Phase Aardvark](#), [Total Phase SPI Cheetah](#), or [Total Phase Promira Serial Platform](#), through J5.

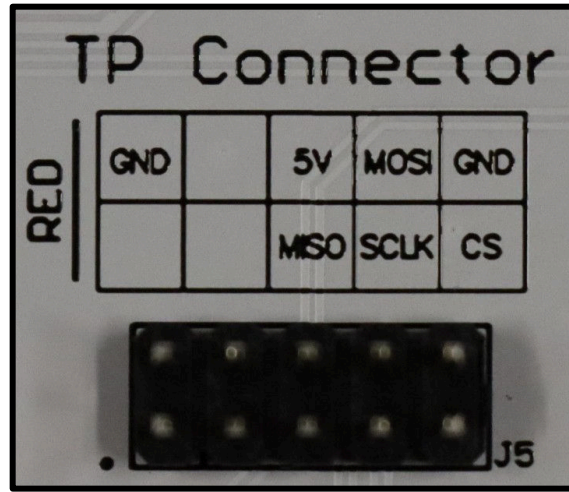

Figure 2-12. Total Phase Products Connect to J5 of the EVM

Common micro controller boards such as [Arduino](#) or [ESP32](#) can also be used via the external header connections for 4-wire SPI on J13.

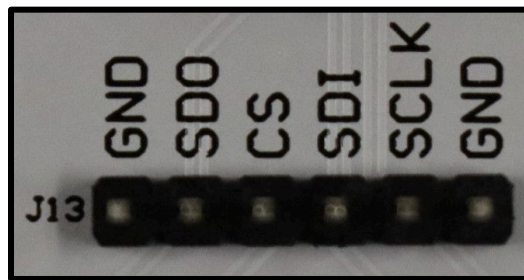

Figure 2-13. Common Dev Boards Such as Arduino and ESP32 Products are Compatible With the TXE81XXEVM Through SPI Headers

2.7 Test Points

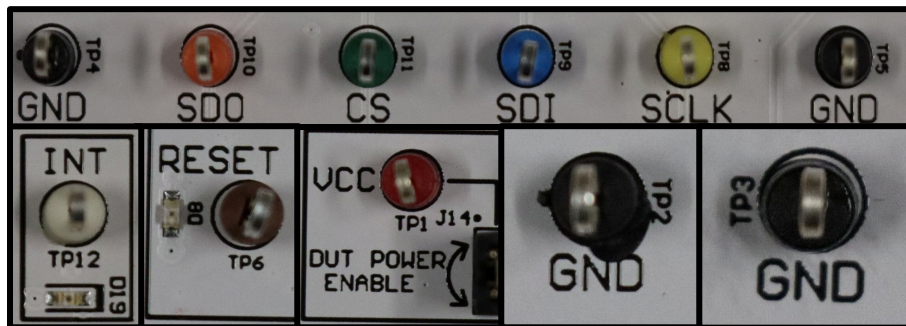

Figure 2-14. Test Points

Table 2-3 describes various test points throughout the EVM.

Table 2-3. Test Point Designator

Test Point Designator	Description
TP1	V _{CC} External Supply Voltage Input
TP2, TP3, TP4, TP5	GND
TP6	RESET
TP8	SCLK - clock
TP9	SDI - data input
TP10	SDO - data output
TP11	CS - chip select
TP12	INT - interrupt

3 Software

3.1 Software Description

For instructions on re-flashing the TXE81XXEVM with the correct firmware - [click here](#)

For instructions on using the USB2ANY Explorer GUI - [click here](#)

3.2 Software Installation

3.2.1 Downloading USB2ANY Firmware (For USB2ANY Explorer or TXE81XXEVM-GUI)

Downloading USB2ANY Firmware version 2.8.2.0 or higher is required for USB2ANY Explorer and TXE81XXEVM-GUI to work.

Note

The TXE81XXEVM is already flashed from the factory with the latest firmware version (2.8.2.0). If the EVM is not connecting to the USB2ANY Explorer, or is having connection issues with the full function GUI, then follow these steps to reflash the device:

To check if the EVM has the updated firmware, follow steps 1-4 below.

1. Download [USB2ANY Explorer Software](#) (SLVC695) from [ti.com](#).
2. Run "USB2ANY Explorer-2.8.2.0 Setup" Application File and install the explorer GUI.
3. Once the install is complete, open USB2ANY Explorer.
4. The USB2ANY Explorer GUI shows the type, serial #, and firmware version underneath the "Adapter Connection" in the GUI. The firmware version reads 2.8.2.0. If the "Firmware Version" shows 2.8.2.0, then the board is ready for use for either USB2ANY Explorer GUI or TXE81XXEVM GUI use. If it does not, follow step 5.

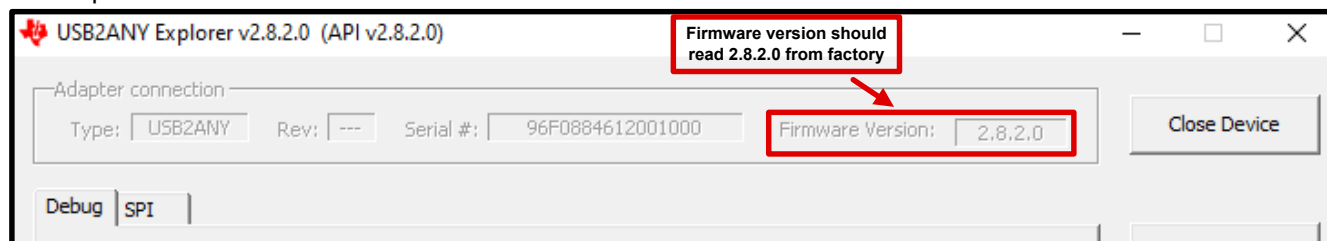

Figure 3-1. Checking Firmware Version of the Board - If Firmware is not up-to-date, follow step 5

5. Disconnect the TXE81XXEVM from the computer.

- Short jumper **J18** on the bottom side of the EVM. This sets up the USB2ANY circuit into programming mode.

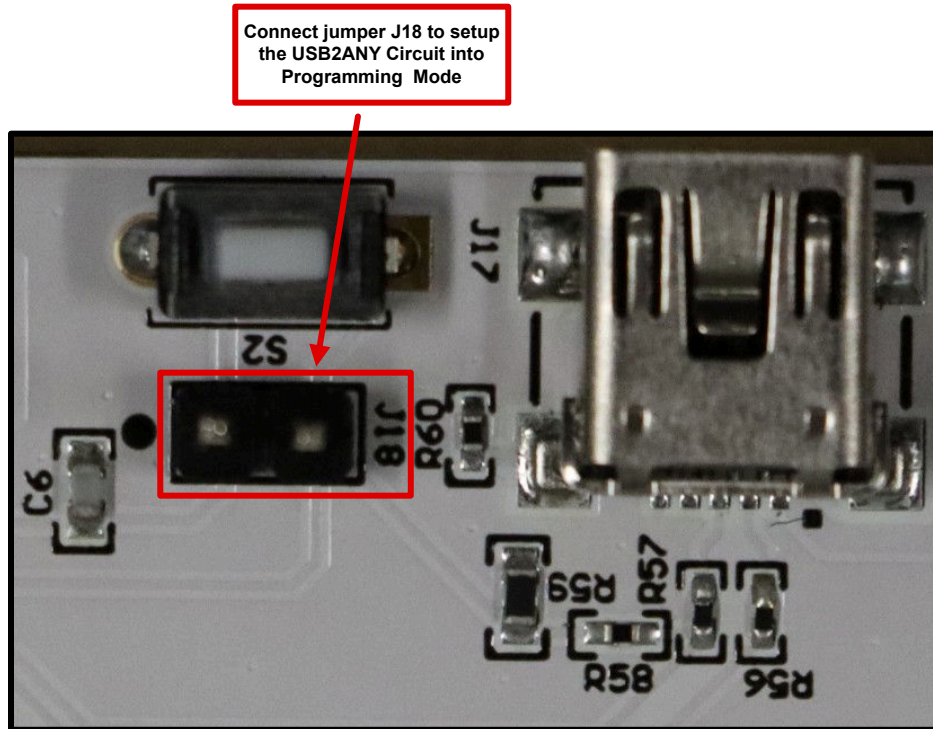

Figure 3-2. Setup the USB2ANY Circuit into Programming Mode by Shorting J18 with a Jumper

- Re-connect the EVM.
- Remove jumper on J18.
- Select "Open Device" in the USB2ANY Explorer GUI and select "Yes".

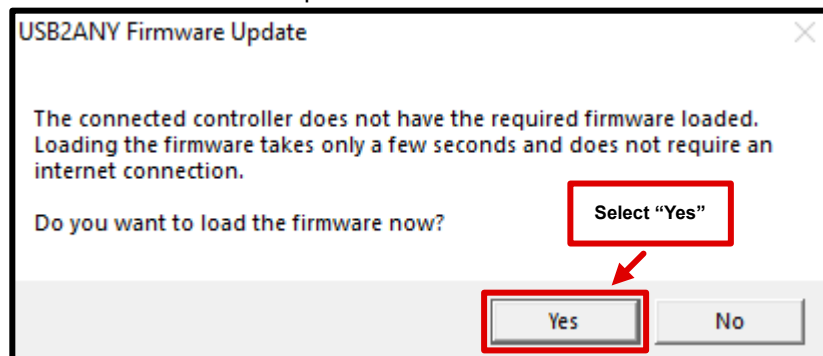

Figure 3-3. Select "Yes"

10. Select "Update Firmware".

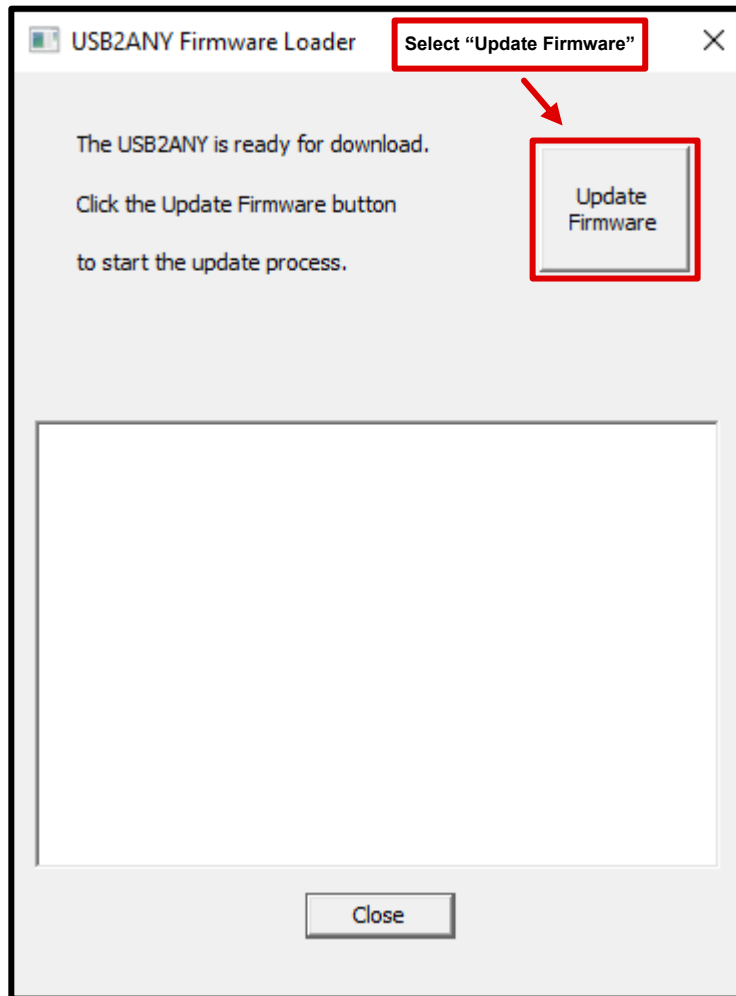

Figure 3-4. Select "Update Firmware"

- Firmware is flashed when the final message says "Done!"

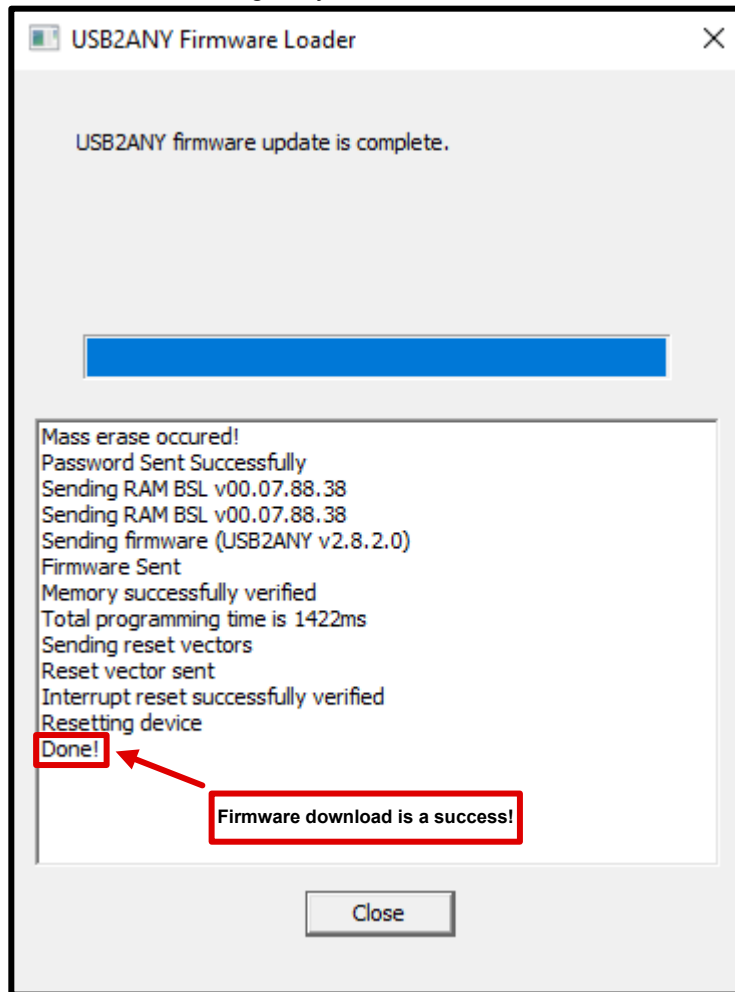

Figure 3-5. Firmware is Updated Successfully When the Console says "Done!"

- The Firmware Version underneath "Adapter Connection" now reads 2.8.2.0. The USB2ANY circuit on the bottom side of the EVM is now correctly flashed and ready for use in the USB2ANY Explorer GUI or TXE81XXEVM GUI.

3.3 GUI Installation

3.3.1 USB2ANY Explorer GUI

Follow these steps to use the USB2ANY Explorer GUI to write and read SPI commands from the TXE81XX.

- Connect the TXE81XXEVM to a computer/laptop with USB2ANY Explorer v2.8.2.0 installed.
- Open USB2ANY Explorer v2.8.2.0 ([Follow steps 1-3 of "Downloading USB2ANY Firmware" for download instructions](#)).

- On the bottom of the TXE81XXEVM, make sure that the SPI switch for SDO/SDI/CS/SCLK is enabled.

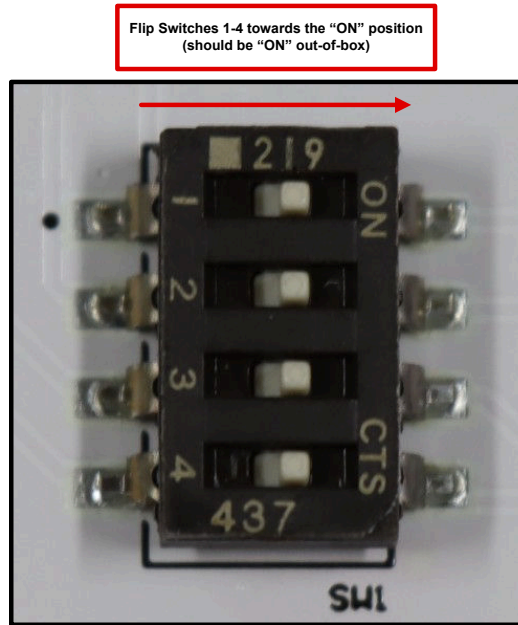

Figure 3-6. Make Sure That the SPI Switch (SW1) is in the "ON" Position

- Make sure that either 5V or 3.3V power jumper (J7 or J10, respectively) is shorted on the TXE81XXEVM. This matches the supply that is enabled in the USB2ANY Explorer GUI (in this case 5V).

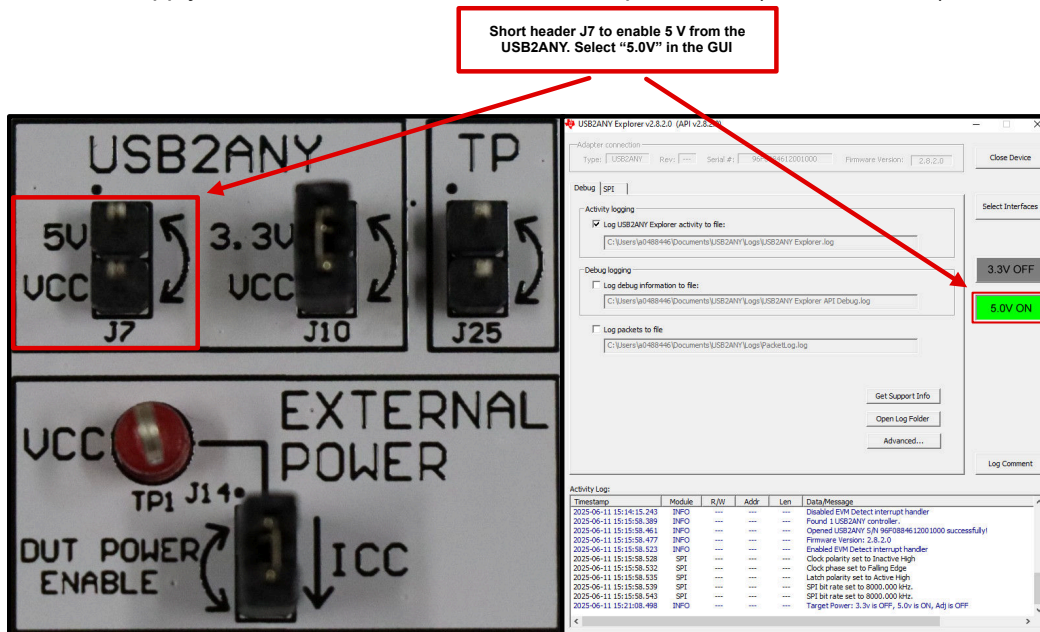

Figure 3-7. Match the Appropriate Header Jump With the Desired Voltage Level (3.3V or 5V)

Note

Do not short both J7 and J10 at the same time. This shorts the 5V supply to the 3.3V supply with potential to create an over-current event if both supplies are enabled in the USB2ANY Explorer GUI.

5. Click "Select Interfaces", select "SPI", and hit "close".

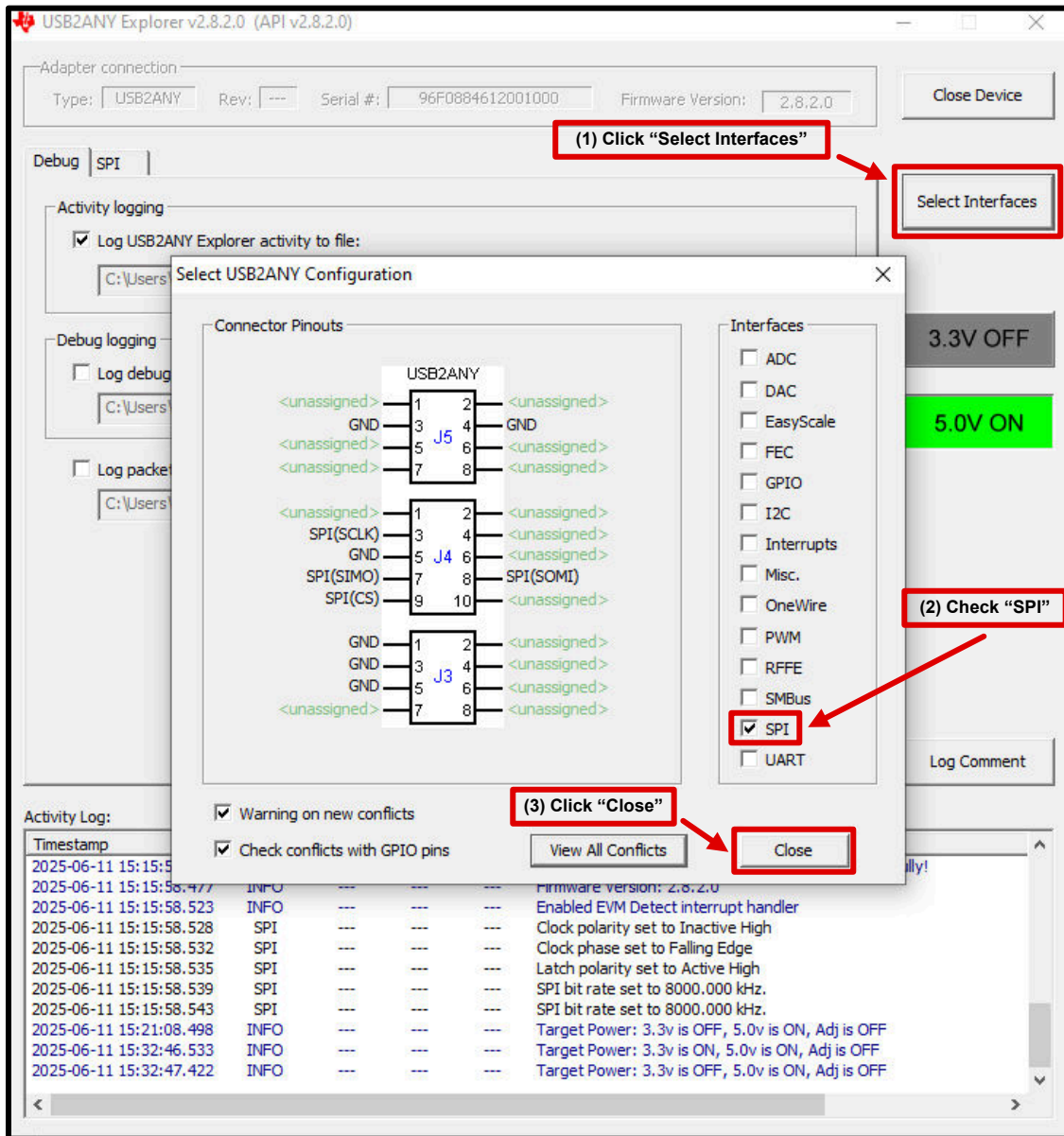

Figure 3-8. Select the "SPI" Interface

6. Open up the SPI tab and select the following configuration for SPI communication:
 - a. Clock Polarity = Inactive Low
 - b. Clock Phase = Leading Edge
 - c. CS Polarity = Active Low
 - d. Bit Direction = MSB First
 - e. Length = 8 bits
 - f. Bit Rate = user preference
 - g. Slave Device = 0
 - h. CS Type = per packet
 - i. # of Bytes = 3

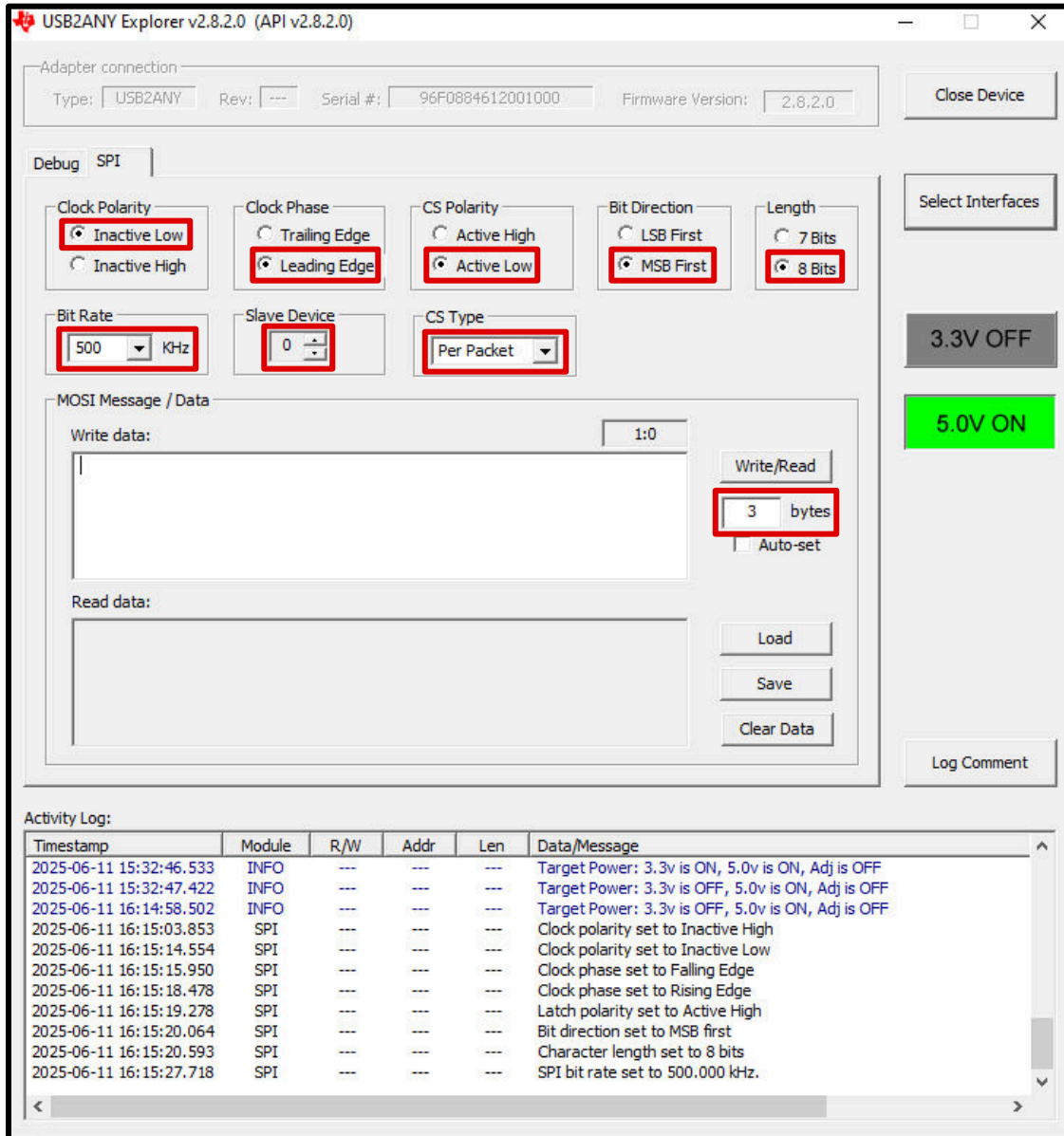

Figure 3-9. Select the Following Requirements in the SPI Window

7. Begin writing/reading SPI data.
 - a. Example, set port 0 GPIO's to OUTPUT through the direction control register (0x04). Write data = 04 00 FF.

The screenshot shows the USB2ANY Explorer v2.8.2.0 (API v2.8.2.0) interface. The 'SPI' tab is active. The 'MOSI Message / Data' section has 'Write data:' set to '04 00 FF' and 'Read data:' set to 'C1 00 FF'. A diagram of the SPI word address is shown, with a red box highlighting the bit fields for Feature Address, Port Selection, and Data. The bit fields are: Feature Address (bits B23-B18), Port Selection (bits B17-B14), and Data (bits B13-B0). The bit values are: Feature Address: 00000100, Port Selection: 00000000, Data: 11111111. The 'Write/Read' button is set to '3 bytes' and 'Auto-set' is unchecked. The 'Activity Log' at the bottom shows a series of SPI transactions.

Timestamp	Module	R/W	Addr	Len	Data/Message
2025-06-27 16:09:48.427	SPI	Write	0x0000	3	Data: 03 00 00
2025-06-27 16:09:48.442	SPI	Read	0x0000	3	Data: C1 00 00
2025-06-27 16:09:52.621	SPI	---	---	---	SPI write/read count set to 3
2025-06-27 16:09:52.624	SPI	Write	0x0000	3	Data: 04 00 FF
2025-06-27 16:09:52.644	SPI	Read	0x0000	3	Data: C1 00 00
2025-06-27 16:10:04.342	SPI	---	---	---	SPI write/read count set to 3
2025-06-27 16:10:04.347	SPI	Write	0x0000	3	Data: 03 00 00
2025-06-27 16:10:04.367	SPI	Read	0x0000	3	Data: C1 00 00
2025-06-27 16:10:35.987	SPI	---	---	---	SPI write/read count set to 3
2025-06-27 16:10:35.994	SPI	Write	0x0000	3	Data: 04 00 FF
2025-06-27 16:10:36.004	SPI	Read	0x0000	3	Data: C1 00 FF

Figure 3-10. Write Data = 04 00 FF, to Set the GPIO's of Port 0 to "OUTPUT"

USB2ANY Explorer v2.8.2.0 (API v2.8.2.0)

Adapter connection: Type: USB2ANY Rev: --- Serial #: D36E98461E000500 Firmware Version: 2.8.2.0

Debug SPI

Clock Polarity: Inactive Low Inactive High

Clock Phase: Trailing Edge Leading Edge

CS Polarity: Active High Active Low

Bit Direction: LSB First MSB First

Length: 7 Bits 8 Bits

Bit Rate: 500 KHz

Slave Device: 0

CS Type: Per Packet

From TXE81XX-Q1 Datasheet

MOSI Message / Data

Write data: 03 00 00

Read data: C1 00 00

Write/Read: 3 bytes

Auto-set:

Load Save Clear Data

Log Comment

Activity Log:

Timestamp	Module	R/W	Addr	Len	Data/Message
2025-06-27 16:09:29.954	SPI	Write	0x0000	3	Data: 03 00 00
2025-06-27 16:09:29.970	SPI	Read	0x0000	3	Data: 00 00 00
2025-06-27 16:09:48.423	SPI	---	---	---	SPI write/read count set to 3
2025-06-27 16:09:48.427	SPI	Write	0x0000	3	Data: 03 00 00
2025-06-27 16:09:48.442	SPI	Read	0x0000	3	Data: C1 00 00
2025-06-27 16:09:52.621	SPI	---	---	---	SPI write/read count set to 3
2025-06-27 16:09:52.624	SPI	Write	0x0000	3	Data: 04 00 FF
2025-06-27 16:09:52.644	SPI	Read	0x0000	3	Data: C1 00 00
2025-06-27 16:10:04.342	SPI	---	---	---	SPI write/read count set to 3
2025-06-27 16:10:04.347	SPI	Write	0x0000	3	Data: 03 00 00
2025-06-27 16:10:04.367	SPI	Read	0x0000	3	Data: C1 00 00

Figure 3-11. Write Data = 03 00 00, to Set the Outputs of Port 0 to "LOW"

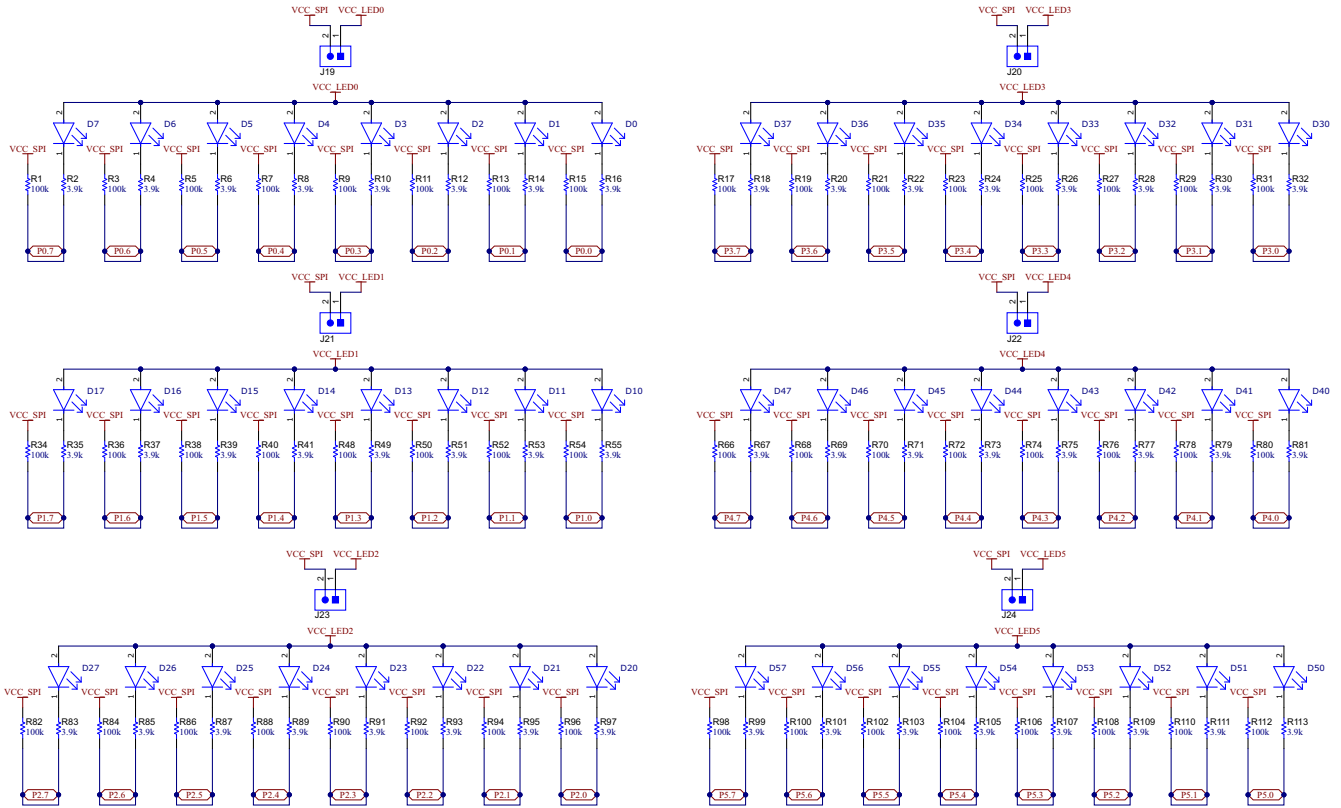

Figure 4-2. Schematic Page 2 - LED Banks

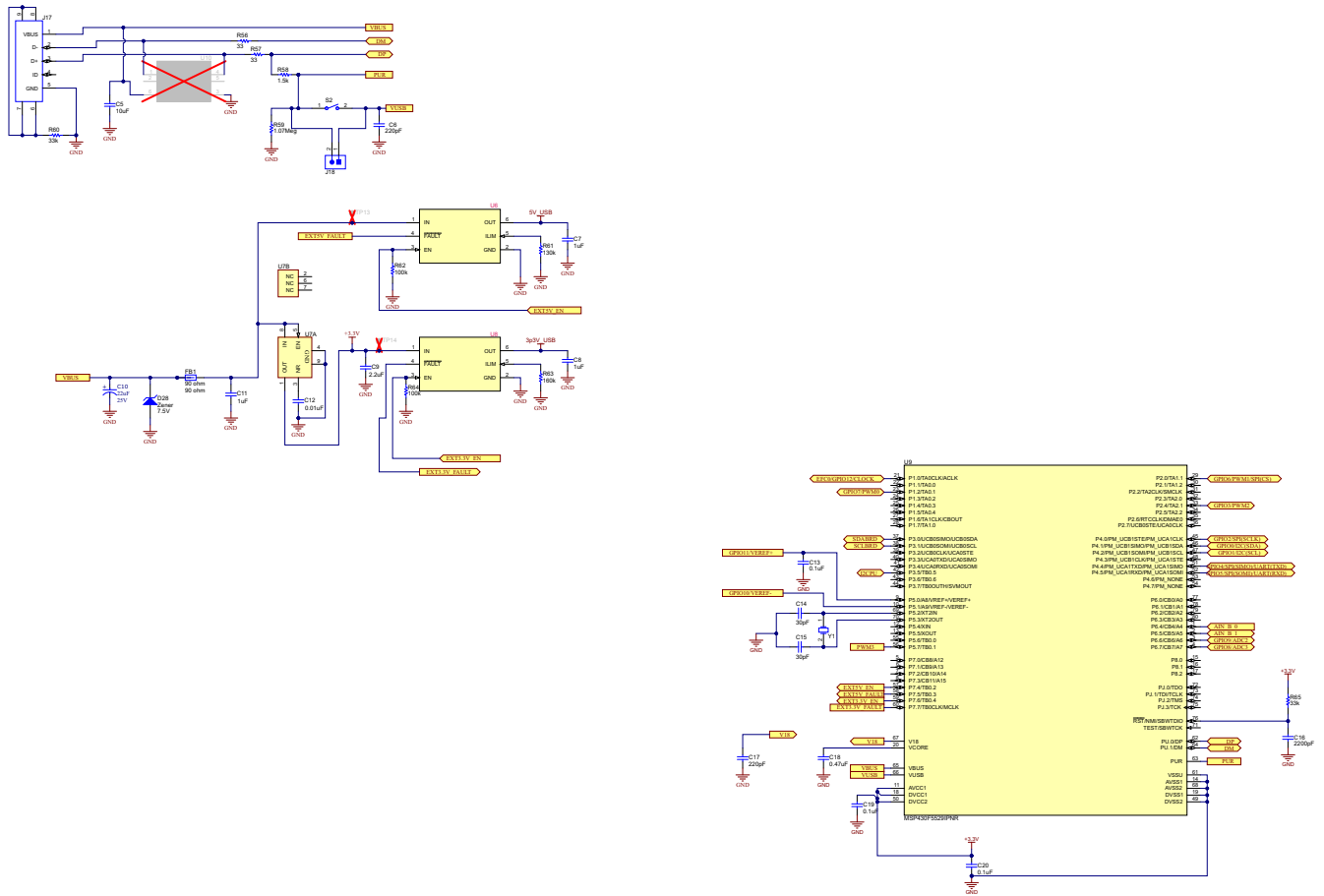

Figure 4-3. USB2ANY Circuitry

4.2 PCB Layouts

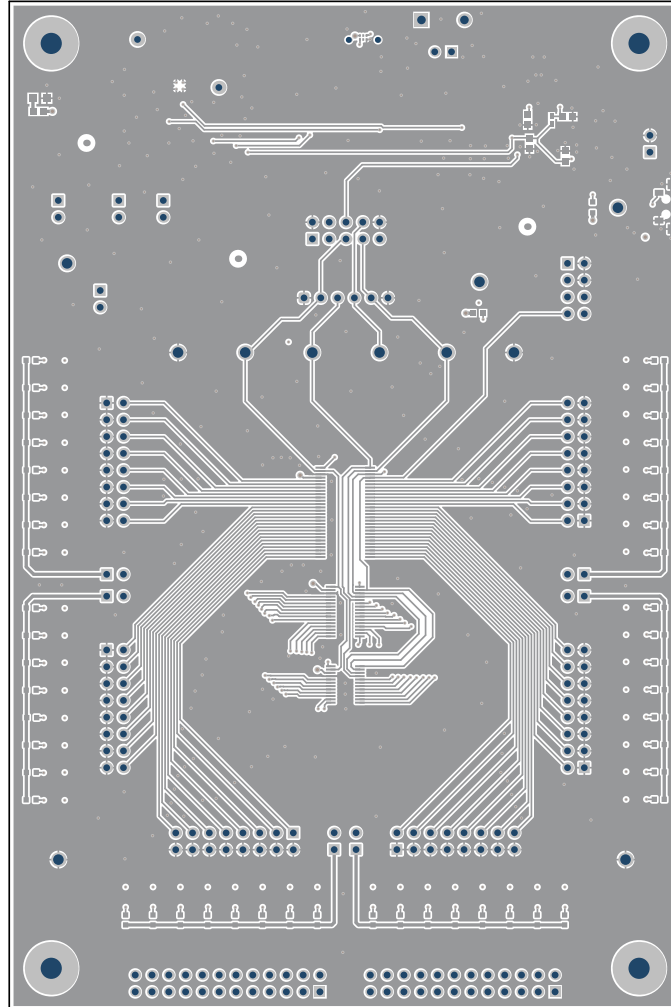

Figure 4-4. Top Layer

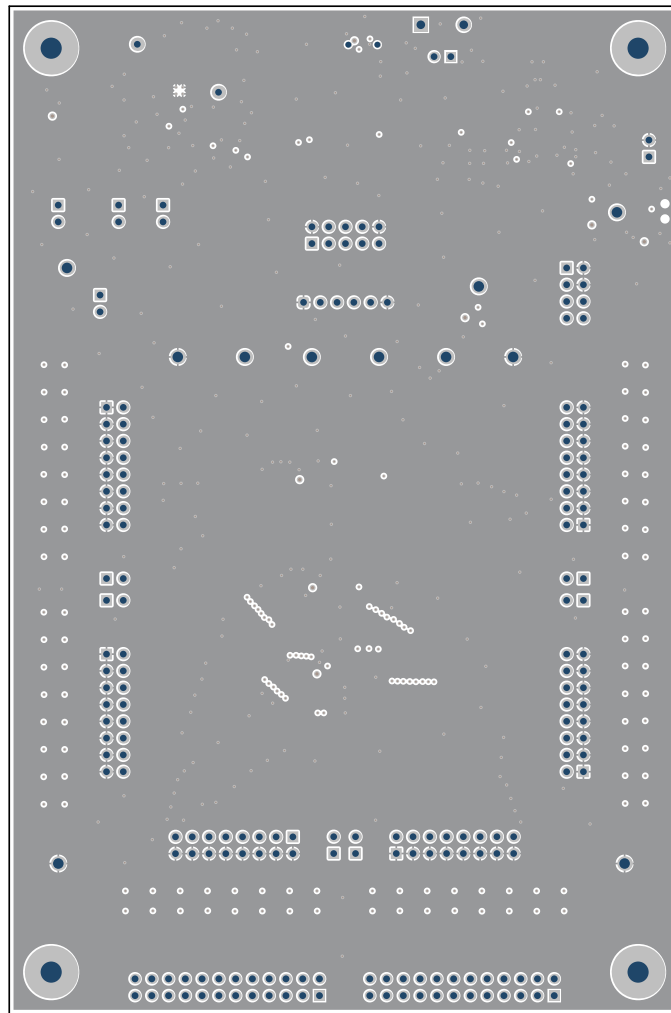

Figure 4-5. Layer 2 - GND

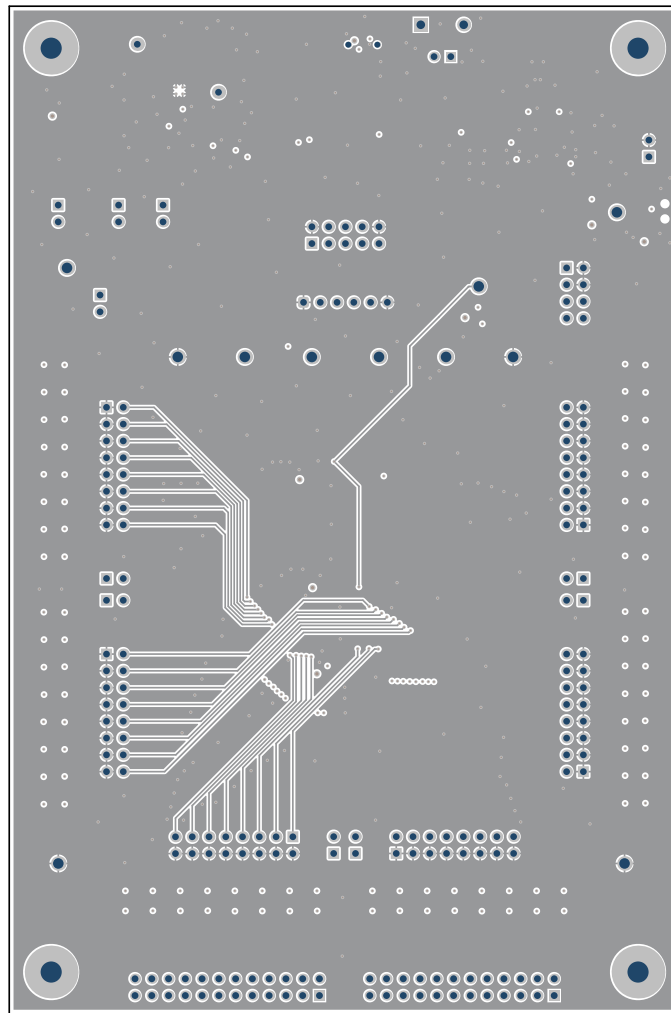

Figure 4-6. Layer 3 - Signal

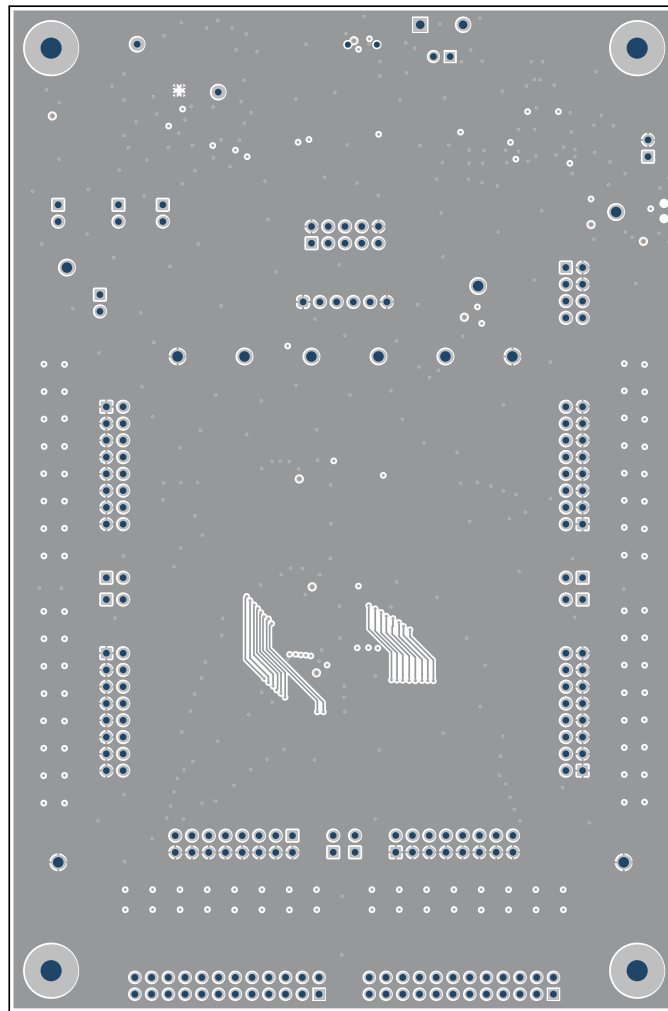

Figure 4-7. Layer 4 - Signal

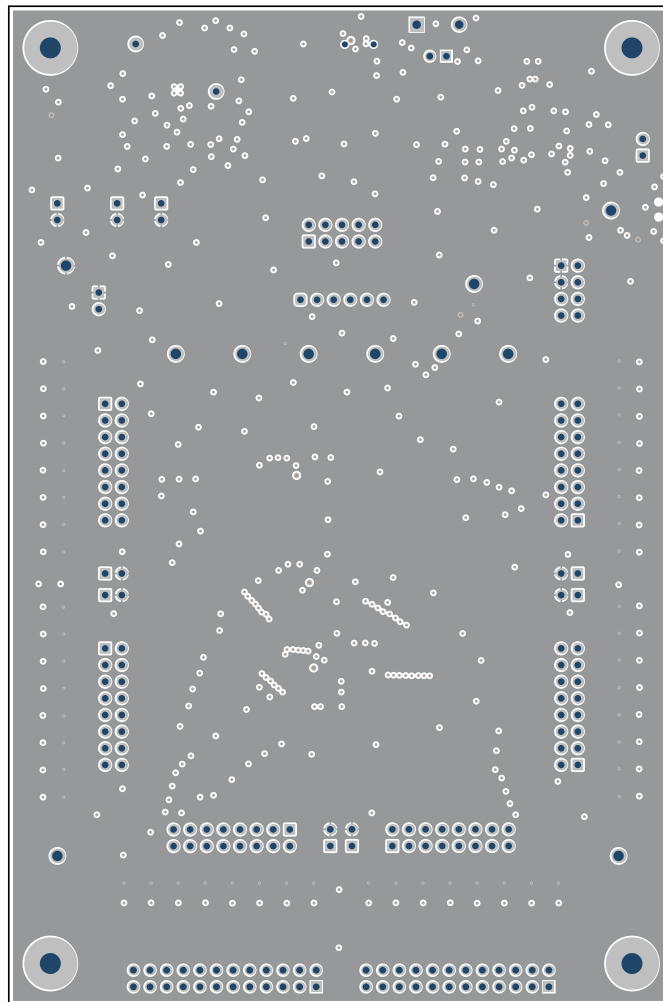

Figure 4-8. Layer 5 - V_{CC}

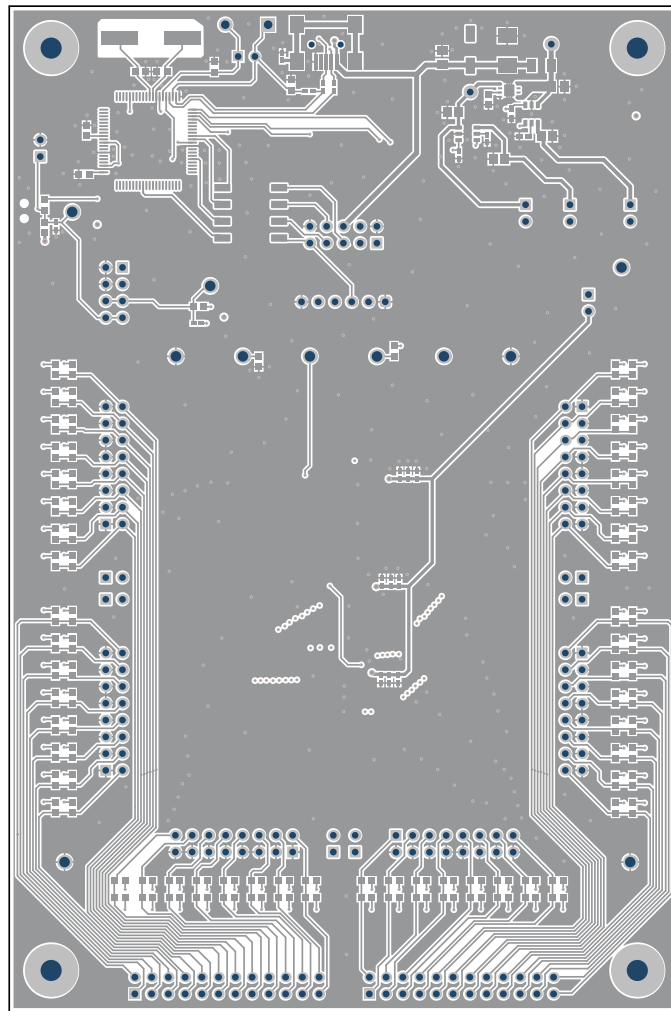

Figure 4-9. Bottom Layer

4.3 Bill of Materials (BOM)

Table 4-1. Bill of Material (BOM)

Designator	Quantity	Value	Part Number	Manufacturer	Description
C4	1	1uF	EMK105BJ105KVHF	Taiyo Yuden	CAP, CERM, 1uF, 16V, ±10%, X5R, 0402
C5	1	10uF	CC0805MKX5R7BB106	YAGEO	CAP, CERM, 10uF, 16V, ±20%, X5R, 080
C6, C17	2	220pF	CC0603FRNPO9BN221	YAGEO	CAP, CERM, 220pF, 50V, ±1%, C0G/NP0, 060
C7, C8	2	1uF	CC0805KRX5R7BB105	YAGEO	CAP, CERM, 1uF, 16V, ±10%, X5R, 0805
C9	1	2.2uF	CC0805KRX5R7BB225	YAGEO	CAP, CERM, 2.2uF, 16V, ±10%, X5R, 0805
C10	1	22uF	EDH226M025S9DAA	KEMET	CAP, AL, 22uF, 25V, ±20%, SMD
C11	1	1uF	CC0805KKX7R7BB105	YAGEO	CAP, CERM, 1uF, 16V, ±10%, X7R, 0805
C12	1	0.0uF	CC0603JRNPO9BN103	YAGEO	CAP, CERM, 0.01uF, 50V, ±5%, C0G/NP0, 0603
C13, C19, C20	3	0.1uF	CC0603JRX7R7BB104	YAGEO	CAP, CERM, 0.1uF, 16V, ±5%, X7R, 0603
C14, C15	2	30pF	CC0603JRNPO9BN300	YAGEO	CAP, CERM, 30pF, 50V, ±5%, C0G/NP0, 0603
C16	1	2200pF	CC0603KRX7R9BB222	YAGEO	CAP, CERM, 2200pF, 50V, ±10%, X7R, 0603
C18	1	0.47uF	CC0603KRX7R6BB474	YAGEO	CAP, CERM, 0.47uF, 10V, ±10%, X7R, 0603
C21, C24, C30	3	0.1uF	CC0402JRX7R7BB104	YAGEO	CAP, CERM, 0.1uF, 16V, ±5%, X7R, 0402
C22, C25, C31	3	1uF	GRM155R61C105MA12D	MuRata	CAP, CERM, 1 μF, 16V, ±20%, X5R, 0402
C23, C26, C32	3	0.01uF	CC0402KRX7R7BB103	YAGEO	CAP, CERM, 0.01μF, 16V, ±10%, X7R, 0402

Table 4-1. Bill of Material (BOM) (continued)

Designator	Quantity	Value	Part Number	Manufacturer	Description
D0, D1, D2, D3, D4, D5, D6, D7, D10, D11, D12, D13, D14, D15, D16, D17, D20, D21, D22, D23, D24, D25, D26, D27, D30, D31, D32, D33, D34, D35, D36, D37, D40, D41, D42, D43, D44, D45, D46, D47, D50, D51, D52, D53, D54, D55, D56, D57	48		LTST-C190TBKT	Lite-On	LED Uni-Color Blue 468nm 2-Pin Chip LED T/R
D8	1	Red	LTST-C190KRKT	Lite-On	LED, Red, SMD
D9	1	Green	LG R971-KN-1	OSRAM	LED, Green, SMD
D19	1	Yellow	150060YS75000	Würth Elektronik	LED, Yellow, SMD
D28	1	7.5V	1SMB5922BT3G	ON Semiconductor	Diode, Zener, 7.5V, 550mW, SMB
FB1	1	90Ω	MI1206K900R-10	Laird-Signal Integrity Products	Ferrite Bead, 90Ω @ 100MHz, 1.5 A, 1206
H1, H2, H3, H4	4		CPF-306A	WEICHIMEI	Machine Screw, Round, #4-40 x 1/4, Nylon, Philips panhead
H5, H6, H7, H8	4		0239 BTH-312	WEICHIMEI	Standoff, Hex, 0.5"L #4-40 Nylon
J1, J2, J3, J8, J9, J11	6		NS-201-SH0384-201S-2*8P(F)	NS-TECH	Header, 100mil, 8x2, Gold, TH
J4, J16	2		NS-203-SH0002-203S-Y-2x12P(F)	NS-TECH	Receptacle, 12x2, 2.54mm, Gold, TH
J5	1		NS-201-SH0384-201S-2*5P(F)	NS-TECH	Header, 100mil, 5x2, Gold, TH
J7, J10, J14, J15, J19, J20, J21, J22, J23, J24, J25	11		NS-201-SH0385-201S-1*2P(F)	NS-TECH	Header, 100mil, 2x1, Gold, TH
J12	1		NS-201-SH0384-201S-2*4P(F)	NS-TECH	Header, 100mil, 4x2, Gold, TH
J13	1		NS-201-SH0385-201S-1*6P(F)	NS-TECH	Header, 100mil, 6x1, Gold, TH
J17	1		1734035-2	TE Connectivity	Connector, Receptacle, Mini-USB Type B, R/A, Top Mount SMT
J18	1		NS-201-SH0385-201S-1*2P(F)	NS-TECH	Header, 100mil, 2x1, Gold, TH

Table 4-1. Bill of Material (BOM) (continued)

Designator	Quantity	Value	Part Number	Manufacturer	Description
R1, R3, R5, R7, R9, R11, R13, R15, R17, R19, R21, R23, R25, R27, R29, R31, R34, R36, R38, R40, R48, R50, R52, R54, R66, R68, R70, R72, R74, R76, R78, R80, R82, R84, R86, R88, R90, R92, R94, R96, R98, R100, R102, R104, R106, R108, R110, R112	48	100k	AC0603JR-07100KL	YAGEO	RES, 100 k, 5%, 0.1 W, AEC-Q200 Grade 0, 0603
R2, R4, R6, R8, R10, R12, R14, R16, R18, R20, R22, R24, R26, R28, R30, R32, R35, R37, R39, R41, R49, R51, R53, R55, R67, R69, R71, R73, R75, R77, R79, R81, R83, R85, R87, R89, R91, R93, R95, R97, R99, R101, R103, R105, R107, R109, R111, R113	48	3.9k	AC0603JR-073K9L	YAGEO	RES, 3.9 k, 5%, 0.1 W, AEC-Q200 Grade 0, 0603
R33	1	560	AC0603JR-07560RL	YAGEO	RES, 560, 5%, 0.1W, 0603
R42	1	300	RC0603JR-07300RL	Yageo	RES, 300, 5%, 0.1W, 0603
R44, R46	2	10k	AC0603JR-0710KL	YAGEO	RES, 10 k, 5%, 0.1W, AEC-Q200 Grade 0, 0603
R47	1	1.00k	RC0402FR-071KL	Yageo America	RES, 1.00k, 1%, 0.0625 W, 0402
R56, R57	2	33	AC0402JR-0733RL	YAGEO	RES, 33, 5%, 0.063W, AEC-Q200 Grade 0, 0402
R58	1	1.5k	AC0402JR-071K5L	YAGEO	RES, 1.5k, 5%, 0.063W, AEC-Q200 Grade 0, 0402
R59	1	1.07Meg	AC0603FR-071M07L	YAGEO	RES, 1.07M, 1%, 0.1W, AEC-Q200 Grade 0, 0603
R60, R65	2	33k	AC0402JR-0733KL	YAGEO	RES, 33k, 5%, 0.063W, AEC-Q200 Grade 0, 0402

Table 4-1. Bill of Material (BOM) (continued)

Designator	Quantity	Value	Part Number	Manufacturer	Description
R61	1	130k	AC0402JR-07130KL	YAGEO	RES, 130k, 5%, 0.063W, AEC-Q200 Grade 0, 0402
R62, R64	2	100k	AC0402JR-07100KL	YAGEO	RES, 100k, 5%, 0.063W, AEC-Q200 Grade 0, 0402
R63	1	160k	AC0402JR-07160KL	YAGEO	RES, 160k, 5%, 0.063W, AEC-Q200 Grade 0, 0402
S1	1		THBM02-LAB	宏聚	Switch, SPST, 0.05A, 12VDC, SMD
S2	1		FSMH	TE Connectivity ALCOSWITCH Switches	Switch, Tactile, SPST-NO, 0.05A, 12V, TH
SW1	1		219-4MSTR	CTS Electrocomponents	Dip Switch SPST 4 Position Surface Mount Slide (Standard) Actuator 100mA 20VDC
TP1	1		Test Point-1P-DIP-H8.1-Φ3.2-Red	FuZhou XiXiang	Test Point, Multipurpose, Red, TH
TP2, TP3, TP4, TP5	4		Test Point-1P-DIP-H8.1-Φ3.2-BLACK	FuZhou XiXiang	Test Point, Multipurpose, Black, TH
TP6	1		5125	Keystone Electronics	Test Point, Multipurpose, Brown, TH
TP8	1		Test Point-1P-DIP-H8.1-Φ3.2-Yellow	FuZhou XiXiang	Test Point, Multipurpose, Yellow, TH
TP9	1		5127	Keystone	Test Point, Multipurpose, Blue, TH
TP10	1		Test Point-1P-DIP-H8.1-Φ3.2-Orange	FuZhou XiXiang	Test Point, Multipurpose, Orange, TH
TP11	1		5126	Keystone	Test Point, Multipurpose, Green, TH
TP12	1		Test Point-1P-DIP-H8.1-Φ3.2-White	FuZhou XiXiang	Test Point, Multipurpose, White, TH
U2	1		TXE8124QDGSRQ1	Texas Instruments	TXE8124QDGSRQ1
U6, U8	2		TPS2553DBVT-1	Texas Instruments	Adjustable, Active High, Latch-off, Current-Limited Power-Distribution Switch, 0.075 to 1.7A Current Limit, -40° to 85°C, 6-pin SOT-23 (DBV), Green (RoHS & no Sb/Br)
U7	1		TPS73533DRBT	Texas Instruments	Single Output High PSRR LDO, 500mA, Fixed 3.3V Output, 2.7 to 6.5V Input, with Low IQ, 8-pin SON (DRB), -40° to 125°C, Green (RoHS & no Sb/Br)
U9	1		MSP430F5529IPNR	Texas Instruments	25MHz Mixed Signal Microcontroller with 128 KB Flash, 8192 B SRAM and 63 GPIOs, -40° to 85°C, 80-pin QFP (PN), Green (RoHS & no Sb/Br)
Y1	1		ECS-240-20-5PX-TR	ECS Inc.	Crystal, 24.000MHz, 20pF, SMD
R43, R45	0	10k	CRCW060310K0JNEA	Vishay-Dale	RES, 10 k, 5%, 0.1W, AEC-Q200 Grade 0, 0603
TP13, TP14	0		5000	Keystone	Test Point, Miniature, Red, TH

Table 4-1. Bill of Material (BOM) (continued)

Designator	Quantity	Value	Part Number	Manufacturer	Description
U3	0		TXE8116QDGSRQ1	Texas Instruments	TXE8116QDGSRQ1
U10	0		TPD4E004DRYR	Texas Instruments	4-Channel ESD Protection Array for High-Speed Data Interfaces, DRY0006A (USON-6)

5 Additional Information

5.1 Trademarks

All trademarks are the property of their respective owners.

5.2 Terminology

SPI terminology changes

6 Revision History

NOTE: Page numbers for previous revisions may differ from page numbers in the current version.

Changes from Revision * (August 2025) to Revision A (May 2026)	Page
• Removed TXE8148 from the document.....	1

STANDARD TERMS FOR EVALUATION MODULES

1. *Delivery:* TI delivers TI evaluation boards, kits, or modules, including any accompanying demonstration software, components, and/or documentation which may be provided together or separately (collectively, an "EVM" or "EVMs") to the User ("User") in accordance with the terms set forth herein. User's acceptance of the EVM is expressly subject to the following terms.
 - 1.1 EVMs are intended solely for product or software developers for use in a research and development setting to facilitate feasibility evaluation, experimentation, or scientific analysis of TI semiconductors products. EVMs have no direct function and are not finished products. EVMs shall not be directly or indirectly assembled as a part or subassembly in any finished product. For clarification, any software or software tools provided with the EVM ("Software") shall not be subject to the terms and conditions set forth herein but rather shall be subject to the applicable terms that accompany such Software
 - 1.2 EVMs are not intended for consumer or household use. EVMs may not be sold, sublicensed, leased, rented, loaned, assigned, or otherwise distributed for commercial purposes by Users, in whole or in part, or used in any finished product or production system.
2. *Limited Warranty and Related Remedies/Disclaimers:*
 - 2.1 These terms do not apply to Software. The warranty, if any, for Software is covered in the applicable Software License Agreement.
 - 2.2 TI warrants that the TI EVM will conform to TI's published specifications for ninety (90) days after the date TI delivers such EVM to User. Notwithstanding the foregoing, TI shall not be liable for a nonconforming EVM if (a) the nonconformity was caused by neglect, misuse or mistreatment by an entity other than TI, including improper installation or testing, or for any EVMs that have been altered or modified in any way by an entity other than TI, (b) the nonconformity resulted from User's design, specifications or instructions for such EVMs or improper system design, or (c) User has not paid on time. Testing and other quality control techniques are used to the extent TI deems necessary. TI does not test all parameters of each EVM. User's claims against TI under this Section 2 are void if User fails to notify TI of any apparent defects in the EVMs within ten (10) business days after delivery, or of any hidden defects with ten (10) business days after the defect has been detected.
 - 2.3 TI's sole liability shall be at its option to repair or replace EVMs that fail to conform to the warranty set forth above, or credit User's account for such EVM. TI's liability under this warranty shall be limited to EVMs that are returned during the warranty period to the address designated by TI and that are determined by TI not to conform to such warranty. If TI elects to repair or replace such EVM, TI shall have a reasonable time to repair such EVM or provide replacements. Repaired EVMs shall be warranted for the remainder of the original warranty period. Replaced EVMs shall be warranted for a new full ninety (90) day warranty period.

WARNING

Evaluation Kits are intended solely for use by technically qualified, professional electronics experts who are familiar with the dangers and application risks associated with handling electrical mechanical components, systems, and subsystems.

User shall operate the Evaluation Kit within TI's recommended guidelines and any applicable legal or environmental requirements as well as reasonable and customary safeguards. Failure to set up and/or operate the Evaluation Kit within TI's recommended guidelines may result in personal injury or death or property damage. Proper set up entails following TI's instructions for electrical ratings of interface circuits such as input, output and electrical loads.

NOTE:

EXPOSURE TO ELECTROSTATIC DISCHARGE (ESD) MAY CAUSE DEGRADATION OR FAILURE OF THE EVALUATION KIT; TI RECOMMENDS STORAGE OF THE EVALUATION KIT IN A PROTECTIVE ESD BAG.

3 Regulatory Notices:

3.1 United States

3.1.1 Notice applicable to EVMs not FCC-Approved:

FCC NOTICE: This kit is designed to allow product developers to evaluate electronic components, circuitry, or software associated with the kit to determine whether to incorporate such items in a finished product and software developers to write software applications for use with the end product. This kit is not a finished product and when assembled may not be resold or otherwise marketed unless all required FCC equipment authorizations are first obtained. Operation is subject to the condition that this product not cause harmful interference to licensed radio stations and that this product accept harmful interference. Unless the assembled kit is designed to operate under part 15, part 18 or part 95 of this chapter, the operator of the kit must operate under the authority of an FCC license holder or must secure an experimental authorization under part 5 of this chapter.

3.1.2 For EVMs annotated as FCC – FEDERAL COMMUNICATIONS COMMISSION Part 15 Compliant:

CAUTION

This device complies with part 15 of the FCC Rules. Operation is subject to the following two conditions: (1) This device may not cause harmful interference, and (2) this device must accept any interference received, including interference that may cause undesired operation.

Changes or modifications not expressly approved by the party responsible for compliance could void the user's authority to operate the equipment.

FCC Interference Statement for Class A EVM devices

NOTE: This equipment has been tested and found to comply with the limits for a Class A digital device, pursuant to part 15 of the FCC Rules. These limits are designed to provide reasonable protection against harmful interference when the equipment is operated in a commercial environment. This equipment generates, uses, and can radiate radio frequency energy and, if not installed and used in accordance with the instruction manual, may cause harmful interference to radio communications. Operation of this equipment in a residential area is likely to cause harmful interference in which case the user will be required to correct the interference at his own expense.

FCC Interference Statement for Class B EVM devices

NOTE: This equipment has been tested and found to comply with the limits for a Class B digital device, pursuant to part 15 of the FCC Rules. These limits are designed to provide reasonable protection against harmful interference in a residential installation. This equipment generates, uses and can radiate radio frequency energy and, if not installed and used in accordance with the instructions, may cause harmful interference to radio communications. However, there is no guarantee that interference will not occur in a particular installation. If this equipment does cause harmful interference to radio or television reception, which can be determined by turning the equipment off and on, the user is encouraged to try to correct the interference by one or more of the following measures:

- Reorient or relocate the receiving antenna.
- Increase the separation between the equipment and receiver.
- Connect the equipment into an outlet on a circuit different from that to which the receiver is connected.
- Consult the dealer or an experienced radio/TV technician for help.

3.2 Canada

3.2.1 For EVMs issued with an Industry Canada Certificate of Conformance to RSS-210 or RSS-247

Concerning EVMs Including Radio Transmitters:

This device complies with Industry Canada license-exempt RSSs. Operation is subject to the following two conditions:

(1) this device may not cause interference, and (2) this device must accept any interference, including interference that may cause undesired operation of the device.

Concernant les EVMs avec appareils radio:

Le présent appareil est conforme aux CNR d'Industrie Canada applicables aux appareils radio exempts de licence. L'exploitation est autorisée aux deux conditions suivantes: (1) l'appareil ne doit pas produire de brouillage, et (2) l'utilisateur de l'appareil doit accepter tout brouillage radioélectrique subi, même si le brouillage est susceptible d'en compromettre le fonctionnement.

Concerning EVMs Including Detachable Antennas:

Under Industry Canada regulations, this radio transmitter may only operate using an antenna of a type and maximum (or lesser) gain approved for the transmitter by Industry Canada. To reduce potential radio interference to other users, the antenna type and its gain should be so chosen that the equivalent isotropically radiated power (e.i.r.p.) is not more than that necessary for successful communication. This radio transmitter has been approved by Industry Canada to operate with the antenna types listed in the user guide with the maximum permissible gain and required antenna impedance for each antenna type indicated. Antenna types not included in this list, having a gain greater than the maximum gain indicated for that type, are strictly prohibited for use with this device.

Concernant les EVMs avec antennes détachables

Conformément à la réglementation d'Industrie Canada, le présent émetteur radio peut fonctionner avec une antenne d'un type et d'un gain maximal (ou inférieur) approuvé pour l'émetteur par Industrie Canada. Dans le but de réduire les risques de brouillage radioélectrique à l'intention des autres utilisateurs, il faut choisir le type d'antenne et son gain de sorte que la puissance isotrope rayonnée équivalente (p.i.r.e.) ne dépasse pas l'intensité nécessaire à l'établissement d'une communication satisfaisante. Le présent émetteur radio a été approuvé par Industrie Canada pour fonctionner avec les types d'antenne énumérés dans le manuel d'usage et ayant un gain admissible maximal et l'impédance requise pour chaque type d'antenne. Les types d'antenne non inclus dans cette liste, ou dont le gain est supérieur au gain maximal indiqué, sont strictement interdits pour l'exploitation de l'émetteur.

3.3 Japan

3.3.1 *Notice for EVMs delivered in Japan:* Please see http://www.tij.co.jp/lstds/ti_ja/general/eStore/notice_01.page 日本国内に輸入される評価用キット、ボードについては、次のところをご覧ください。

<https://www.ti.com/ja-jp/legal/notice-for-evaluation-kits-delivered-in-japan.html>

3.3.2 *Notice for Users of EVMs Considered "Radio Frequency Products" in Japan:* EVMs entering Japan may not be certified by TI as conforming to Technical Regulations of Radio Law of Japan.

If User uses EVMs in Japan, not certified to Technical Regulations of Radio Law of Japan, User is required to follow the instructions set forth by Radio Law of Japan, which includes, but is not limited to, the instructions below with respect to EVMs (which for the avoidance of doubt are stated strictly for convenience and should be verified by User):

1. Use EVMs in a shielded room or any other test facility as defined in the notification #173 issued by Ministry of Internal Affairs and Communications on March 28, 2006, based on Sub-section 1.1 of Article 6 of the Ministry's Rule for Enforcement of Radio Law of Japan,
2. Use EVMs only after User obtains the license of Test Radio Station as provided in Radio Law of Japan with respect to EVMs, or
3. Use of EVMs only after User obtains the Technical Regulations Conformity Certification as provided in Radio Law of Japan with respect to EVMs. Also, do not transfer EVMs, unless User gives the same notice above to the transferee. Please note that if User does not follow the instructions above, User will be subject to penalties of Radio Law of Japan.

【無線電波を送信する製品の開発キットをお使いになる際の注意事項】 開発キットの中には技術基準適合証明を受けていないものがあります。技術適合証明を受けていないものご使用に際しては、電波法遵守のため、以下のいずれかの措置を取っていただく必要がありますのでご注意ください。

1. 電波法施行規則第6条第1項第1号に基づく平成18年3月28日総務省告示第173号で定められた電波暗室等の試験設備でご使用いただく。
2. 実験局の免許を取得後ご使用いただく。
3. 技術基準適合証明を取得後ご使用いただく。

なお、本製品は、上記の「ご使用にあたっての注意」を譲渡先、移転先に通知しない限り、譲渡、移転できないものとします。

上記を遵守頂けない場合は、電波法の罰則が適用される可能性があることをご留意ください。日本テキサス・イ

ンスツルメンツ株式会社

東京都新宿区西新宿 6 丁目 2 4 番 1 号

西新宿三井ビル

3.3.3 *Notice for EVMs for Power Line Communication:* Please see http://www.tij.co.jp/lstds/ti_ja/general/eStore/notice_02.page

電力線搬送波通信についての開発キットをお使いになる際の注意事項については、次のところをご覧ください。 <https://www.ti.com/ja-jp/legal/notice-for-evaluation-kits-for-power-line-communication.html>

3.4 European Union

3.4.1 *For EVMs subject to EU Directive 2014/30/EU (Electromagnetic Compatibility Directive):*

This is a class A product intended for use in environments other than domestic environments that are connected to a low-voltage power-supply network that supplies buildings used for domestic purposes. In a domestic environment this product may cause radio interference in which case the user may be required to take adequate measures.

-
4. *EVM Use Restrictions and Warnings:*
 - 4.1 EVMS ARE NOT FOR USE IN FUNCTIONAL SAFETY AND/OR SAFETY CRITICAL EVALUATIONS, INCLUDING BUT NOT LIMITED TO EVALUATIONS OF LIFE SUPPORT APPLICATIONS.
 - 4.2 User must read and apply the user guide and other available documentation provided by TI regarding the EVM prior to handling or using the EVM, including without limitation any warning or restriction notices. The notices contain important safety information related to, for example, temperatures and voltages.
 - 4.3 *Safety-Related Warnings and Restrictions:*
 - 4.3.1 User shall operate the EVM within TI's recommended specifications and environmental considerations stated in the user guide, other available documentation provided by TI, and any other applicable requirements and employ reasonable and customary safeguards. Exceeding the specified performance ratings and specifications (including but not limited to input and output voltage, current, power, and environmental ranges) for the EVM may cause personal injury or death, or property damage. If there are questions concerning performance ratings and specifications, User should contact a TI field representative prior to connecting interface electronics including input power and intended loads. Any loads applied outside of the specified output range may also result in unintended and/or inaccurate operation and/or possible permanent damage to the EVM and/or interface electronics. Please consult the EVM user guide prior to connecting any load to the EVM output. If there is uncertainty as to the load specification, please contact a TI field representative. During normal operation, even with the inputs and outputs kept within the specified allowable ranges, some circuit components may have elevated case temperatures. These components include but are not limited to linear regulators, switching transistors, pass transistors, current sense resistors, and heat sinks, which can be identified using the information in the associated documentation. When working with the EVM, please be aware that the EVM may become very warm.
 - 4.3.2 EVMs are intended solely for use by technically qualified, professional electronics experts who are familiar with the dangers and application risks associated with handling electrical mechanical components, systems, and subsystems. User assumes all responsibility and liability for proper and safe handling and use of the EVM by User or its employees, affiliates, contractors or designees. User assumes all responsibility and liability to ensure that any interfaces (electronic and/or mechanical) between the EVM and any human body are designed with suitable isolation and means to safely limit accessible leakage currents to minimize the risk of electrical shock hazard. User assumes all responsibility and liability for any improper or unsafe handling or use of the EVM by User or its employees, affiliates, contractors or designees.
 - 4.4 User assumes all responsibility and liability to determine whether the EVM is subject to any applicable international, federal, state, or local laws and regulations related to User's handling and use of the EVM and, if applicable, User assumes all responsibility and liability for compliance in all respects with such laws and regulations. User assumes all responsibility and liability for proper disposal and recycling of the EVM consistent with all applicable international, federal, state, and local requirements.
 5. *Accuracy of Information:* To the extent TI provides information on the availability and function of EVMs, TI attempts to be as accurate as possible. However, TI does not warrant the accuracy of EVM descriptions, EVM availability or other information on its websites as accurate, complete, reliable, current, or error-free.
 6. *Disclaimers:*
 - 6.1 EXCEPT AS SET FORTH ABOVE, EVMS AND ANY MATERIALS PROVIDED WITH THE EVM (INCLUDING, BUT NOT LIMITED TO, REFERENCE DESIGNS AND THE DESIGN OF THE EVM ITSELF) ARE PROVIDED "AS IS" AND "WITH ALL FAULTS." TI DISCLAIMS ALL OTHER WARRANTIES, EXPRESS OR IMPLIED, REGARDING SUCH ITEMS, INCLUDING BUT NOT LIMITED TO ANY EPIDEMIC FAILURE WARRANTY OR IMPLIED WARRANTIES OF MERCHANTABILITY OR FITNESS FOR A PARTICULAR PURPOSE OR NON-INFRINGEMENT OF ANY THIRD PARTY PATENTS, COPYRIGHTS, TRADE SECRETS OR OTHER INTELLECTUAL PROPERTY RIGHTS.
 - 6.2 EXCEPT FOR THE LIMITED RIGHT TO USE THE EVM SET FORTH HEREIN, NOTHING IN THESE TERMS SHALL BE CONSTRUED AS GRANTING OR CONFERRING ANY RIGHTS BY LICENSE, PATENT, OR ANY OTHER INDUSTRIAL OR INTELLECTUAL PROPERTY RIGHT OF TI, ITS SUPPLIERS/LICENSORS OR ANY OTHER THIRD PARTY, TO USE THE EVM IN ANY FINISHED END-USER OR READY-TO-USE FINAL PRODUCT, OR FOR ANY INVENTION, DISCOVERY OR IMPROVEMENT, REGARDLESS OF WHEN MADE, CONCEIVED OR ACQUIRED.
 7. *USER'S INDEMNITY OBLIGATIONS AND REPRESENTATIONS.* USER WILL DEFEND, INDEMNIFY AND HOLD TI, ITS LICENSORS AND THEIR REPRESENTATIVES HARMLESS FROM AND AGAINST ANY AND ALL CLAIMS, DAMAGES, LOSSES, EXPENSES, COSTS AND LIABILITIES (COLLECTIVELY, "CLAIMS") ARISING OUT OF OR IN CONNECTION WITH ANY HANDLING OR USE OF THE EVM THAT IS NOT IN ACCORDANCE WITH THESE TERMS. THIS OBLIGATION SHALL APPLY WHETHER CLAIMS ARISE UNDER STATUTE, REGULATION, OR THE LAW OF TORT, CONTRACT OR ANY OTHER LEGAL THEORY, AND EVEN IF THE EVM FAILS TO PERFORM AS DESCRIBED OR EXPECTED.

8. *Limitations on Damages and Liability:*

8.1 *General Limitations.* IN NO EVENT SHALL TI BE LIABLE FOR ANY SPECIAL, COLLATERAL, INDIRECT, PUNITIVE, INCIDENTAL, CONSEQUENTIAL, OR EXEMPLARY DAMAGES IN CONNECTION WITH OR ARISING OUT OF THESE TERMS OR THE USE OF THE EVMS , REGARDLESS OF WHETHER TI HAS BEEN ADVISED OF THE POSSIBILITY OF SUCH DAMAGES. EXCLUDED DAMAGES INCLUDE, BUT ARE NOT LIMITED TO, COST OF REMOVAL OR REINSTALLATION, ANCILLARY COSTS TO THE PROCUREMENT OF SUBSTITUTE GOODS OR SERVICES, RETESTING, OUTSIDE COMPUTER TIME, LABOR COSTS, LOSS OF GOODWILL, LOSS OF PROFITS, LOSS OF SAVINGS, LOSS OF USE, LOSS OF DATA, OR BUSINESS INTERRUPTION. NO CLAIM, SUIT OR ACTION SHALL BE BROUGHT AGAINST TI MORE THAN TWELVE (12) MONTHS AFTER THE EVENT THAT GAVE RISE TO THE CAUSE OF ACTION HAS OCCURRED.

8.2 *Specific Limitations.* IN NO EVENT SHALL TI'S AGGREGATE LIABILITY FROM ANY USE OF AN EVM PROVIDED HEREUNDER, INCLUDING FROM ANY WARRANTY, INDEMNITY OR OTHER OBLIGATION ARISING OUT OF OR IN CONNECTION WITH THESE TERMS, , EXCEED THE TOTAL AMOUNT PAID TO TI BY USER FOR THE PARTICULAR EVM(S) AT ISSUE DURING THE PRIOR TWELVE (12) MONTHS WITH RESPECT TO WHICH LOSSES OR DAMAGES ARE CLAIMED. THE EXISTENCE OF MORE THAN ONE CLAIM SHALL NOT ENLARGE OR EXTEND THIS LIMIT.

9. *Return Policy.* Except as otherwise provided, TI does not offer any refunds, returns, or exchanges. Furthermore, no return of EVM(s) will be accepted if the package has been opened and no return of the EVM(s) will be accepted if they are damaged or otherwise not in a resalable condition. If User feels it has been incorrectly charged for the EVM(s) it ordered or that delivery violates the applicable order, User should contact TI. All refunds will be made in full within thirty (30) working days from the return of the components(s), excluding any postage or packaging costs.

10. *Governing Law:* These terms and conditions shall be governed by and interpreted in accordance with the laws of the State of Texas, without reference to conflict-of-laws principles. User agrees that non-exclusive jurisdiction for any dispute arising out of or relating to these terms and conditions lies within courts located in the State of Texas and consents to venue in Dallas County, Texas. Notwithstanding the foregoing, any judgment may be enforced in any United States or foreign court, and TI may seek injunctive relief in any United States or foreign court.

Mailing Address: Texas Instruments, Post Office Box 655303, Dallas, Texas 75265
Copyright © 2023, Texas Instruments Incorporated

IMPORTANT NOTICE AND DISCLAIMER

TI PROVIDES TECHNICAL AND RELIABILITY DATA (INCLUDING DATASHEETS), DESIGN RESOURCES (INCLUDING REFERENCE DESIGNS), APPLICATION OR OTHER DESIGN ADVICE, WEB TOOLS, SAFETY INFORMATION, AND OTHER RESOURCES "AS IS" AND WITH ALL FAULTS, AND DISCLAIMS ALL WARRANTIES, EXPRESS AND IMPLIED, INCLUDING WITHOUT LIMITATION ANY IMPLIED WARRANTIES OF MERCHANTABILITY, FITNESS FOR A PARTICULAR PURPOSE OR NON-INFRINGEMENT OF THIRD PARTY INTELLECTUAL PROPERTY RIGHTS.

These resources are intended for skilled developers designing with TI products. You are solely responsible for (1) selecting the appropriate TI products for your application, (2) designing, validating and testing your application, and (3) ensuring your application meets applicable standards, and any other safety, security, regulatory or other requirements.

These resources are subject to change without notice. TI grants you permission to use these resources only for development of an application that uses the TI products described in the resource. Other reproduction and display of these resources is prohibited. No license is granted to any other TI intellectual property right or to any third party intellectual property right. TI disclaims responsibility for, and you fully indemnify TI and its representatives against any claims, damages, costs, losses, and liabilities arising out of your use of these resources.

TI's products are provided subject to [TI's Terms of Sale](#), [TI's General Quality Guidelines](#), or other applicable terms available either on ti.com or provided in conjunction with such TI products. TI's provision of these resources does not expand or otherwise alter TI's applicable warranties or warranty disclaimers for TI products. Unless TI explicitly designates a product as custom or customer-specified, TI products are standard, catalog, general purpose devices.

TI objects to and rejects any additional or different terms you may propose.

Copyright © 2026, Texas Instruments Incorporated

Last updated 10/2025