

# **AN-1293 Driving RGB LED Using LP3936 Lighting Management System**

---

## **ABSTRACT**

This application report discusses the LP3936 Lighting Management System.

---

### **Contents**

1	Introduction .....	2
2	Controls .....	3
	2.1 On/Off Controls .....	3
	2.2 Brightness Control .....	3
	2.3 Blinking Control .....	5
	2.4 Slope Control .....	6
3	FLASH .....	7
4	Current Limiting Resistors .....	9
5	Control Registers .....	10
6	Slope Values .....	11
7	Programming Examples .....	12
	7.1 Programming Example 1 .....	12
	7.2 Programming Example 2 .....	13
	7.3 Programming Example 3 .....	14

### **List of Figures**

1	Functional Block Diagram of the RGB Driver in LP3936 .....	2
2	Continuous Mode Operation .....	3
3	Continuous Mode PWM Control .....	3
4	Normal Mode PWM Control .....	4
5	FLASH Mode PWM Control .....	4
6	RGB LED Blinking Control Principle .....	5
7	Blinking Waveforms (LED Average Currents) .....	6
8	Slope Variations .....	6
9	Flash with White LED Flash Module .....	7
10	Flash with RGB LED .....	8
11	Flash Using White LED Module with Viewfinder .....	8
12	Flash Using RGB LED or Several White LEDs with Viewfinder .....	8

### **List of Tables**

1	Blinking Period Control .....	5
2	Maximum Slope Values .....	7
3	Resistor Size Calculation, FLASH and Normal Modes in Use .....	9
4	Resistor Size Calculation, FLASH Mode Used as Normal Mode .....	10
5	LP3936 Control Registers .....	10
6	LP3936 Slope Times .....	11

All trademarks are the property of their respective owners.

## 1 Introduction

The LP3936 Lighting Management IC contains a versatile RGB Driver. It needs only a few register writes through the serial interface to start and maintain complex blinking patterns thus reducing microcontroller loading.

RGB driver has three low-impedance open-drain outputs, ROOUT (red), GOOUT (green) and BOOUT (blue), for driving one three-color LED or three LEDs of any kind.

Timing and brightness of each output can be controlled separately, making color blending and different blinking sequences possible. A high current FLASH mode is also available.

A functional block diagram of the RGB driver is shown in Figure 1. It shows in detail the structure of the blue output control channel. The green and red channels have identical structure.

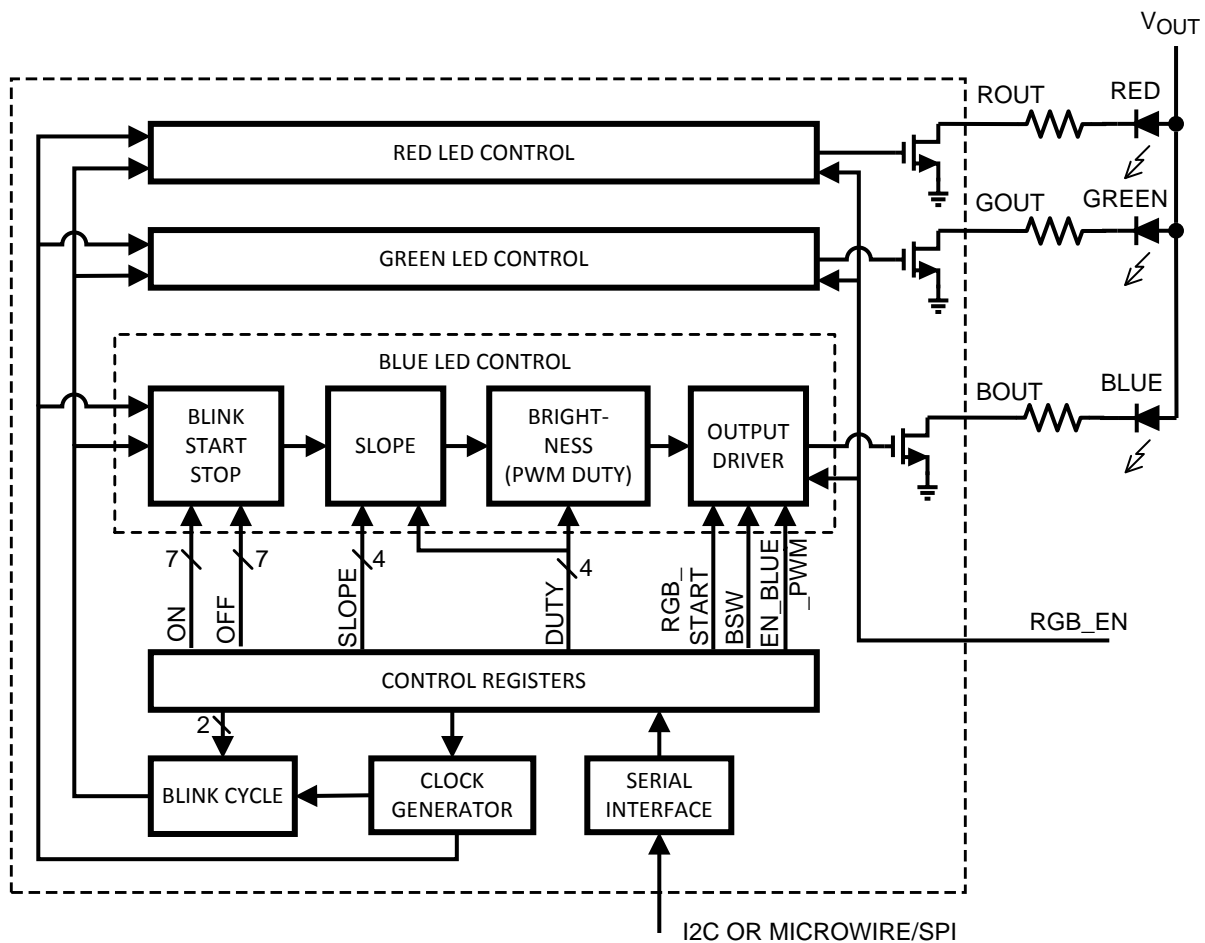

**Figure 1. Functional Block Diagram of the RGB Driver in LP3936**

## 2 Controls

LP3936 has 15 user controllable registers. The complete register map is listed in [Table 5](#).

### 2.1 On/Off Controls

The RGB Driver is enabled by writing the RGB\_START control bit high. This is the master control for the RGB driver. Each output has an enable bit to turn it on or off (RSW, GSW and BSW).

The RGB\_EN pin can be used as a hardware on and off control or for external PWM brightness control. This control can be enabled for each output (control bits EN\_RED\_PWM, EN\_GREEN\_PWM, EN\_BLUE\_PWM). The default value after reset for these controls is enabled.

### 2.2 Brightness Control

LED brightness is proportional to its current. With the LP3936 an external resistor, the output voltage, and the LED voltage drop determine the maximum current for each LED. The maximum brightness is achieved when the LEDs are continuously switched on. This continuous mode can be entered by setting control bit RGB\_PWM low, RGB\_START high and desired LED outputs high. In this mode only on/off control is possible. [Figure 2](#) shows waveforms of two outputs in continuous mode.

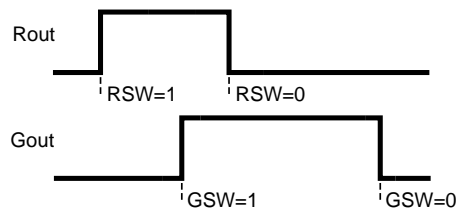

**Figure 2. Continuous Mode Operation**

The RGB\_EN input pin can be used as an additional brightness control of selected LEDs by applying a PWM waveform to it. Control bits EN\_RED\_PWM, EN\_GREEN\_PWM, EN\_BLUE\_PWM enable this control to the RGB outputs. Bits EN\_4LED\_PWM and EN\_2LED\_PWM enable control to the two groups of white LEDs. [Figure 3](#) shows the ROUT output in the following conditions (RGB\_PWM = 0, RGB\_START = 1):

1. output off
2. output continuously on
3. output PWM controlled by RGB\_EN, 30% duty cycle
4. output off
5. output PWM controlled by RGB\_EN, 70% duty cycle

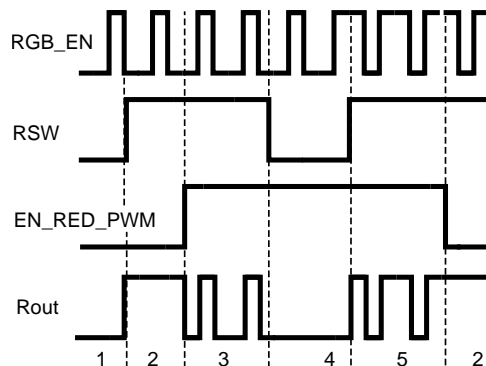

**Figure 3. Continuous Mode PWM Control**

In the normal mode, the RGB Driver controls the LED brightness by turning the LEDs on and off in a PWM fashion (Pulse Width Modulated). This mode is entered by setting control bit RGB\_PWM high. The PWM waveform is produced from an internal clock signal. The PWM period is 50  $\mu$ s. In the normal PWM mode, the three color outputs are enabled in successive PWM periods, and the combined PWM period is 150  $\mu$ s (6.67 kHz). Each output has maximum pulse width of 47  $\mu$ s in a 150  $\mu$ s PWM cycle, giving a maximum duty cycle of 31.3%. Example waveforms with different duty cycles are shown in [Figure 4](#).

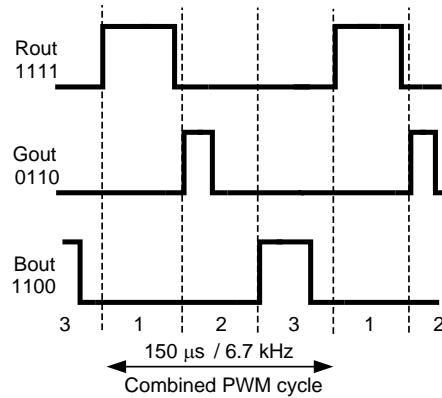

**Figure 4. Normal Mode PWM Control**

In FLASH mode, all outputs are simultaneously on, and the PWM frequency is 20 kHz (50  $\mu$ s). The maximum duty cycle is 94% (47  $\mu$ s). EN\_FLASH enables the FLASH mode. FLASH mode PWM current waveforms at different DUTY settings are shown in [Figure 5](#).

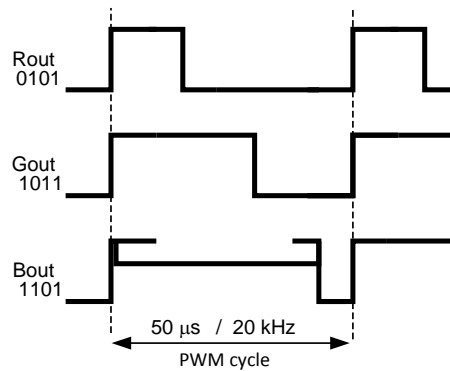

**Figure 5. FLASH Mode PWM Control**

The brightness is controlled in both FLASH and normal mode with 4 bits (DUTY[3:0]) between 0% and the maximum duty cycle.

The time averaged LED current in FLASH and normal modes can be calculated from the following equations.

$$I = I_{max} \times N_{DUTY} / 16 \times D_{RGB\_EN} \text{ (FLASH)} \tag{1}$$

$$I = I_{max} \times N_{DUTY} / (3 \times 16) \times D_{RGB\_EN} \text{ (normal)} \tag{2}$$

where:

$I_{max}$  = Maximum LED current (peak)

$N_{DUTY}$  = Duty cycle control setting (0–15)

$D_{RGB\_EN}$  = RGB\_EN signal duty cycle (0–100%)

$D_{RGB\_EN}$  has effect only if external PWM control is enabled for the LED.

### 2.3 Blinking Control

Figure 6 shows the different blinking controls of the RGB driver. Blinking cycle defines the blinking frequency. ON and OFF times define the turn-on and turn-off times within the blinking cycle. SLOPE defines the interval during which the brightness increases from 0 to the defined brightness and similarly the dimming time. DUTY defines the maximum brightness during the cycle.

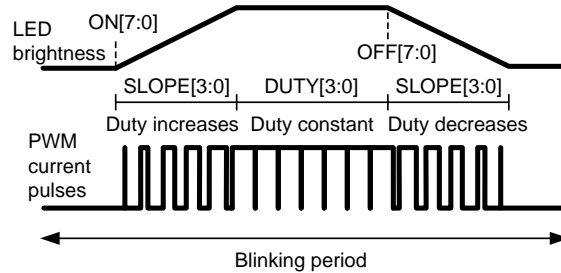

Figure 6. RGB LED Blinking Control Principle

Blinking period is selected from 4 predefined values using control bits CYCLE[1:0] as shown in Table 1.

Table 1. Blinking Period Control

Cycle 1	Cycle 0	Period (s)
0	0	0.25
0	1	0.5
1	0	1.0
1	1	2.0

Each color has its own on and off controls. These determine the turn-on and turn-off times within the blinking period with 7-bit resolution according to the following equation:

$$t_{on/off} = t_{cycle} \times N_{on/off} / 128 \tag{3}$$

where:

$t_{on/off}$  = ON or OFF time from cycle start

$t_{cycle}$  = selected cycle period (0.25/0.5/1/2 s)

$N_{on/off}$  = ON or OFF setting (0–127)

If  $t_{on}$  occurs before  $t_{off}$ , the light pulse is within one blink period. The decreasing slope may extend to the next period, if  $t_{off}$  is close to the cycle end. This situation is shown in the ROUT waveform in Figure 7.

If  $t_{off}$  occurs before  $t_{on}$ , the pulse will start in one blinking period and end in the next period. This situation is shown in the GOUT waveform in Figure 7.

An example of the blinking waveforms is shown in Figure 7. ROUT is set blinking with ON time before OFF time within the cycle. GOUT has OFF time before ON time. GOUT has a smaller (faster) SLOPE setting than ROUT. BOUT has been set to be continuously on by setting ON and OFF times to 0. If ON and OFF times are set the same, but not 0, the output is continuously off. DUTY settings determine the brightness of each LED during blinking.

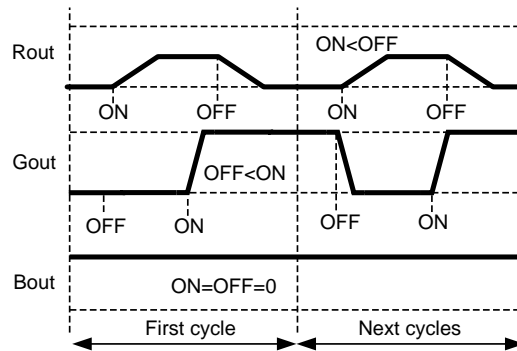
**Figure 7. Blinking Waveforms (LED Average Currents)**

## 2.4 Slope Control

LED turn-on and dimming speed during blinking can be adjusted with the 4 bit SLOPE[3:0] setting, as shown in Figure 6. During turn-on, the slope control increases the PWM duty cycle (LED current) from 0 to the set DUTY value. During turn-off, the slope control decreases the PWM duty cycle from the DUTY value to 0.

If the programmed blinking pulse is shorter than the programmed slope period, the turn-off slope will begin before the LED reaches the programmed brightness. If the off-time in the blinking cycle is programmed shorter than the slope period, the LED will turn off at the blinking on-time, and the turn-on slope will begin from 0. These situations are shown in Figure 8.

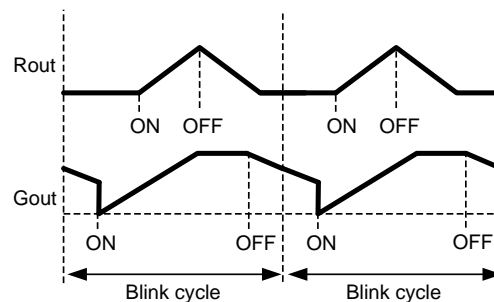
**Figure 8. Slope Variations**

The slope duration is defined at maximum DUTY setting (15) as shown in Table 2. If the DUTY setting is smaller, the slope period will be respectively smaller due to constant slope speed. The slope period  $t_{\text{SLOPE}}$  for any SLOPE and DUTY setting can be calculated with the following formula.

$$t_{\text{SLOPE}} = t_{\text{Smax}} \times N_{\text{duty}} / 15 \text{ (ms)} \quad (4)$$

where:

$t_{\text{Smax}}$  = slope period of selected SLOPE setting at maximum DUTY (15)

$N_{\text{duty}}$  = DUTY setting (0–15)

The SLOPE values at maximum DUTY are shown in Table 2. All slope values are shown in Table 6.

Note that the cycle length programming has no effect on slope period.

**Table 2. Maximum Slope Values**

SLOPE Setting	$t_{\text{SLOPE}}$ (ms) (at DUTY = 15)
0	31
1	62
2	124
3	186
4	248
5	310
6	372
7	434
8	496
9	558
10	620
11	682
12	744
13	806
14	868
15	930

### 3 FLASH

FLASH function is intended to drive a cell phone camera's flashlight, but it can be used for driving other high current loads, too. The RGB driver supports the FLASH function. The flash LED can be a RGB LED (combination of RED + GREEN + BLUE → WHITE), a single high-power white LED, or several lower-power white LEDs in parallel. If a RGB LED is used, it is possible to adjust the color balance by adjusting the brightness of the colors separately.

The FLASH LED current must be limited with external resistors to 120 mA per RGB input. Lower current values can be used if maximum intensity is not needed. The Boost converter can drive up to 250 mA of current at low battery condition. Therefore maximum FLASH LED currents may have to be limited and other LEDs during FLASH may need to be turned off.

There are several options for controlling the flash. The simplest is the continuous mode, but the color balance and brightness cannot be adjusted in this mode. In FLASH mode, the brightness can be controlled for each output separately and the other RGB driver can be used normally at the same time.

Figure 9 shows how the flash can be done using a white-LED flash module. RGB driver outputs can be connected in parallel to drive up to 360 mA maximum current. The current is set using one resistor. The flash can be triggered from the serial bus, or if the flash has to be synchronized to a hardware signal, the RGB\_EN input can be used.

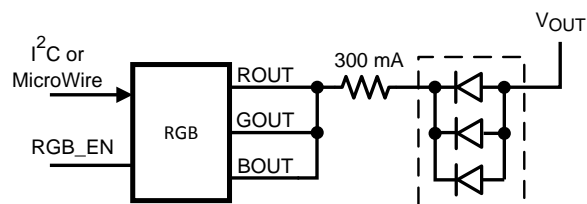
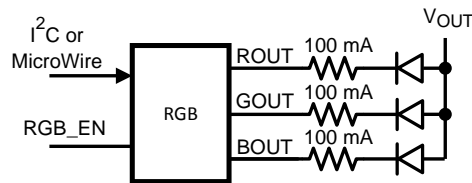
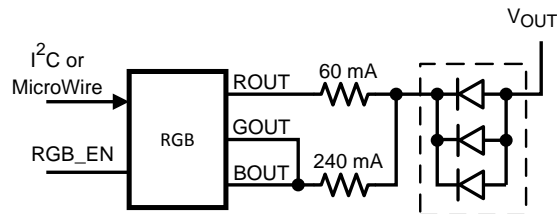

**Figure 9. Flash with White LED Flash Module**

Figure 10 shows the flash done with a RGB LED. Each color requires its own ballast resistor due to different forward voltages and different dynamic resistances of the LEDs. If a viewfinder light (pre-light before the flash) is needed, it can be done using a lower brightness duty setting first and then full brightness. One way is to use normal mode setting for viewfinder and flash mode for the flash.



**Figure 10. Flash with RGB LED**

Figure 11 shows how a viewfinder light can be driven from one color output and the flash driven from two other outputs connected in parallel. The viewfinder output can be on during the flash for increasing the flash current. In this way the viewfinder light is continuous whereas the light is PWM modulated when internal duty control is used.



**Figure 11. Flash Using White LED Module with Viewfinder**

Figure 12 shows the flash connection using RGB LED with viewfinder. It is easy to use just one color in viewfinder mode if desired by connecting just one of the LEDs to ROUT output. The color balance adjustment can be done with internal duty setting or with external ballast resistors. In both cases the viewfinder mode needs to be started using serial interface and the flash can be controlled either via serial interface or using RGB\_EN pin. Programming Examples 2 and 3 show the control sequences for different flash types.

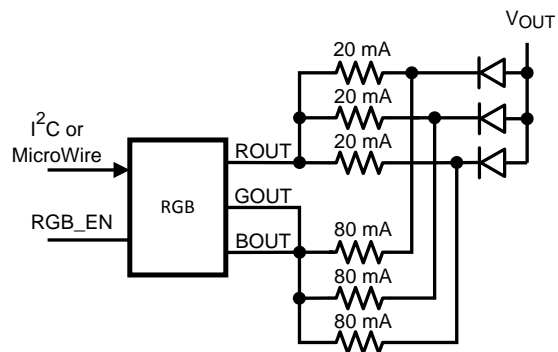

**Figure 12. Flash Using RGB LED or Several White LEDs with Viewfinder**



## 4 Current Limiting Resistors

LED forward voltages vary widely depending on LED color, current, manufacturer, manufacturing lot, temperature etc. White, blue and some green LEDs exhibit the largest forward voltages and variations. The high dynamic resistance of these LEDs at high currents further adds to the voltage drop in FLASH operation. The drop may exceed 5V.

The maximum peak current for each individual RGB output is 120 mA. This current is available in continuous mode and in FLASH mode. In normal mode the maximum average current is 31% of the continuous and FLASH mode current, but the peak current will be the same in all cases.

The current limiting resistor size can be calculated from the following formula.

$$R_{LED} = (V_{OUT} - V_{LED})/I_{max} - R_{SW} \quad (5)$$

where:

$V_{OUT}$  = DC/DC converter output voltage

$V_{LED}$  = LED drop at  $I_{max}$

$I_{max}$  = Selected maximum peak current

$R_{SW}$  = Output switch resistance

Table 3 and Table 4 show the voltages and current limiting resistors at 75 mA and 25 mA PWM peak currents. As the input power calculation shows, if high FLASH currents are not needed, it is better to use the circuit in FLASH mode and limit the current to the normal value with external resistors. Lower LED peak current makes possible to use lower boost voltage to improve efficiency.

Boost output voltage is selected sufficiently higher than the highest LED forward voltage. Sharp RGB LED GM5WA06250 forward voltages are used in these examples. A nominal switch resistance of 3Ω is used in the calculations. Other values are calculated as:

$$V_{SW} = R_{SW} \times I_{LED} \quad (6)$$

$$V_R = V_{OUT} - V_{LED} - V_{SW} \quad (7)$$

$$R_{LED} = V_R/I_{LED} \quad (8)$$

**Table 3. Resistor Size Calculation, FLASH and Normal Modes in Use**

	Red	Green	Blue	Unit
$I_{LED}$	75	75	75	mA
$V_{OUT}$	5,30	5,30	5,30	V
$V_{LED}$	2,60	4,80	5,00	V
$V_{SW}$	0,23	0,23	0,23	V
$V_R$	2,48	0,28	0,07	V
$R_{LED}$	33,00	3,67	1,00	Ω
Power in FLASH mode			1,19	W
Power in normal mode			0,40	W

**Table 4. Resistor Size Calculation, FLASH Mode Used as Normal Mode**

	Red	Green	Blue	Unit
$I_{LED}$	25	25	25	mA
$V_{OUT}$	4,50	4,50	4,50	V
$V_{LED}$	2,30	3,80	4,00	V
$V_{SW}$	0,08	0,08	0,08	V
$V_R$	2,13	0,63	0,43	V
$R_{LED}$	85,00	25,00	17,00	$\Omega$
Power in FLASH mode			0,34	W

## 5 Control Registers

LP3936 control registers and register bits are shown in [Table 5](#). Bits set in **boldface type** are read-only bits from the ADC.

**Table 5. LP3936 Control Registers**

Addr (Hex)	Setup	D7	D6	D5	D4	D3	D2	D1	D0
<b>00</b>	Control register	rgb pwm	rgb start	cycle[1]	cycle[0]	rsw	gsw	bsw	pfm_mode
<b>01</b>	ron		ron[6]	ron[5]	ron[4]	ron[3]	ron[2]	ron[1]	ron[0]
<b>02</b>	roff		roff[6]	roff[5]	roff[4]	roff[3]	roff[2]	roff[1]	roff[0]
<b>03</b>	gon		gon[6]	gon[5]	gon[4]	gon[3]	gon[2]	gon[1]	gon[0]
<b>04</b>	goff		goff[6]	goff[5]	goff[4]	goff[3]	goff[2]	goff[1]	goff[0]
<b>05</b>	bon		bon[6]	bon[5]	bon[4]	bon[3]	bon[2]	bon[1]	bon[0]
<b>06</b>	boff		boff[6]	boff[5]	boff[4]	boff[3]	boff[2]	boff[1]	boff[0]
<b>07</b>	rslope, rduty	rslope[3]	rslope[2]	rslope[1]	rslope[0]	rduty[3]	rduty[2]	rduty[1]	rduty[0]
<b>08</b>	gslope, gduty	gslope[3]	gslope[2]	gslope[1]	gslope[0]	gduty[3]	gduty[2]	gduty[1]	gduty[0]
<b>09</b>	bslope, bduty	bslope[3]	bslope[2]	bslope[1]	bslope[0]	bduty[3]	bduty[2]	bduty[1]	bduty[0]
<b>0A</b>	wled current 1	wled1[7]	wled1[6]	wled1[5]	wled1[4]	wled1[3]	wled1[2]	wled1[1]	wled1[0]
<b>0B</b>	enables	<b>overflow</b>	nstby	en_boost	en_flash	en_ambave	en_ambadc	en_4led	en_2led
<b>0C</b>	Amb. Light data	<b>ain[7]</b>	<b>ain[6]</b>	<b>ain[5]</b>	<b>ain[4]</b>	<b>ain[3]</b>	<b>ain[2]</b>	<b>ain[1]</b>	<b>ain[0]</b>
<b>0D</b>	boost output	boost[7]	boost[6]	boost[5]	boost[4]	boost[3]	boost[2]	boost[1]	boost[0]
<b>2A</b>	wled current 2	wled2[7]	wled2[6]	wled2[5]	wled2[4]	wled2[3]	wled2[2]	wled2[1]	wled2[0]
<b>2B</b>	ext pwm enable				en_red_pwm	en_green_pwm	en_blue_pwm	en_4led_pwm	en_2led_pwm

## 6 Slope Values

All slope times in milliseconds at different SLOPE and DUTY settings are shown in [Table 6](#). The CYCLE setting does not affect slope time.

**Table 6. LP3936 Slope Times**

Slope	Duty															
	0	2	4	6	8	10	12	14	17	19	21	23	25	27	29	31
0	0	2	4	6	8	10	12	14	17	19	21	23	25	27	29	31
1	0	4	8	12	17	21	25	29	33	37	41	45	50	54	58	62
2	0	8	17	25	33	41	50	58	66	74	83	91	99	107	116	124
3	0	12	25	37	50	62	74	87	99	112	124	136	149	161	174	186
4	0	17	33	50	66	83	99	116	132	149	165	182	198	215	231	248
5	0	21	41	62	83	103	124	145	165	186	207	227	248	269	289	310
6	0	25	50	74	99	124	149	174	198	223	248	273	298	322	347	372
7	0	29	58	87	116	145	174	203	231	260	289	318	347	376	405	434
8	0	33	66	99	132	165	198	231	265	298	331	364	397	430	463	496
9	0	37	74	112	149	186	223	260	298	335	372	409	446	484	521	558
10	0	41	83	124	165	207	248	289	331	372	413	455	496	537	579	620
11	0	45	91	136	182	227	273	318	364	409	455	500	546	591	637	682
12	0	50	99	149	198	248	298	347	397	446	496	546	595	645	694	744
13	0	54	107	161	215	269	322	376	430	484	537	591	645	699	752	806
14	0	58	116	174	231	289	347	405	463	521	579	637	694	752	810	868
15	0	62	124	186	248	310	372	434	496	558	620	682	744	806	868	930

## 7 Programming Examples

### 7.1 Programming Example 1

Blinking according to [Figure 7](#)

50% duty cycle for red color; Maximum duty cycles for green and blue colors

Cycle time is 2 seconds

Slope of the ROUT is maximum (15, slowest); Slope of the GOUT is 6

BOUT is continuously on

1. Reset the chip after power on and turn the chip on
2. Set RON to switch ROUT on at 15% of the cycle
3. Set ROFF to switch ROUT off at 60% of the cycle
4. Set GON to switch GOUT off at 50% of the cycle
5. Set GOFF to switch GOUT off at 15% of the cycle
6. Set BON to 0%
7. Set BOFF to 0% (when BON = BOFF = 0% no blinking, DUTY controls brightness)
8. Set RDUTY, RSLOPE to achieve 50% duty and maximum slope
9. Set GDUTY, GSLOPE to achieve maximum duty and slope
10. Set BDUTY to achieve maximum intensity of the BOUT
11. Set EXT\_PWM\_ENABLE register to 0 to disable external control of LEDs
12. Set CYCLE to achieve a period of 2 seconds and turn RGB LEDs on

Step	Description	Register Name Register Address (Hex)	Set to (Hex)
1	Set NSTBY to 1 Set EN_BOOST to 1	ENABLES 0B	60
2	Set RON to 15% (RON = 19)	RON 01	13
3	Set ROFF to 60% (ROFF = 76)	ROFF 02	4C
4	Set GON to 50% (GON = 64)	GON 03	40
5	Set GOFF to 15% (GOFF = 19)	GOFF 04	13
6	Set BON to 0 (BON = 0)	BON 05	00
7	Set BOFF to 0 (BOFF = 0)	BOFF 06	00
8	Set RDUTY to 50% (RDUTY = 8) Set RSLOPE to MAX (RSLOPE = 15)	RSLOPE, RDUTY 07	F8
9	Set GDUTY to MAX (GDUTY = 15) Set GSLOPE to 6 (GSLOPE = 6)	GSLOPE, GDUTY 08	6F
10	Set BDUTY to MAX (BDUTY = 15) Set BSLOPE to 0 (BSLOPE = 0)	BSLOPE, BDUTY 09	0F
11	Set EN_RED_PWM, EN_GREEN_PWM, and EN_BLUE_PWM to 0	EXT PWM ENABLE 2B	00
12	Set CYCLE to 2 seconds (CYCLE = 3) Set RSW, GSW, and BSW to 1 Set RGB_PWM and RGB_START to 1	CONTROL 00	FE

## 7.2 Programming Example 2

Software triggered FLASH mode flash

Flash length 100 ms

Flash light is adjusted white by adjusting individual color brightnesses

1. Reset the chip after power on, turn the chip on and set FLASH mode
2. Set RON to 0% (continuously on when RON = ROFF = 0%)
3. Set ROFF to 0% (continuously on when RON = ROFF = 0%)
4. Set GON to 0% (continuously on)
5. Set GOFF to 0% (continuously on)
6. Set BON to 0% (continuously on)
7. Set BOFF to 0% (continuously on)
8. Set RDUTY to 40%
9. Set GDUTY to 67%
10. Set BDUTY to 100%
11. Set EXT\_PWM\_ENABLE register to 0 to disable external control of LEDs
12. Turn RGB LEDs on
13. Turn RGB LEDs off **after 100 ms**

Step	Description	Register Name Register Address (Hex)	Set to (Hex)
1	Set NSTBY to 1 Set EN_BOOST to 1 Set EN_FLASH to 1	ENABLES 0B	70
2	Set RON to 0% (RON = 0)	RON 01	00
3	Set ROFF to 0% (ROFF = 0)	ROFF 02	00
4	Set GON to 0% (GON = 0)	GON 03	00
5	Set GOFF to 0% (GOFF = 0)	GOFF 04	00
6	Set BON to 0 (BON = 0)	BON 05	00
7	Set BOFF to 0 (BOFF = 0)	BOFF 06	00
8	Set RDUTY to 40% (RDUTY = 6) Set RSLOPE to 0 (RSLOPE = 0)	RSLOPE, RDUTY 07	06
9	Set GDUTY to 67% (GDUTY = 10) Set GSLOPE to 0 (GSLOPE = 0)	GSLOPE, GDUTY 08	0A
10	Set BDUTY to 100% (BDUTY = 15) Set BSLOPE to 0 (BSLOPE = 0)	BSLOPE, BDUTY 09	0F
11	Set EN_RED_PWM, EN_GREEN_PWM, and EN_BLUE_PWM to 0	EXT PWM ENABLE 2B	00
12	Set RSW, GSW, and BSW to 1 Set RGB_PWM and RGB_START to 1	CONTROL 00	CE
13	Set RSW, GSW, and BSW to 0 Set RGB_PWM and RGB_START to 0	CONTROL 00	00

### 7.3 Programming Example 3

FLASH with viewfinder controlled from RGB\_EN input according to [Figure 11](#) and [Figure 12](#).

ROUT output used for viewfinder and GOUT and BOUT used for flash

RGB driver used in continuous mode

Viewfinder length 1 second and flash length 100 ms

1. Reset the chip after power on, turn the chip on (RGB\_EN input is low)
2. Enable RGB\_EN control for GOUT and BOUT outputs
3. Start viewfinder by setting RGB\_START and RSW to 1. GSW and BSW can be set to 1; GOUT and BOUT will turn on only after RGB\_EN input goes high.
4. After 1s start flash by taking RGB\_EN high for 100 ms
5. Disable RGB outputs

Step	Description	Register Name Register Address (Hex)	Set to (Hex)
1	Set NSTBY to 1 Set EN_BOOST to 1	ENABLES 0B	60
2	Set EN_RED_PWM to 0 Set EN_GREEN_PWM and EN_BLUE_PWM to 1	EXT PWM ENABLE 2B	0C
3	Set RSW, GSW, and BSW to 1 Set RGB_START to 1	CONTROL 00	4E
4	Wait 1 second Take RBG_EN input high for 100 ms		
5	Set RSW, GSW, and BSW to 0 Set RGB_PWM and RGB_START to 0	CONTROL 00	00

## IMPORTANT NOTICE

Texas Instruments Incorporated and its subsidiaries (TI) reserve the right to make corrections, enhancements, improvements and other changes to its semiconductor products and services per JESD46, latest issue, and to discontinue any product or service per JESD48, latest issue. Buyers should obtain the latest relevant information before placing orders and should verify that such information is current and complete. All semiconductor products (also referred to herein as "components") are sold subject to TI's terms and conditions of sale supplied at the time of order acknowledgment.

TI warrants performance of its components to the specifications applicable at the time of sale, in accordance with the warranty in TI's terms and conditions of sale of semiconductor products. Testing and other quality control techniques are used to the extent TI deems necessary to support this warranty. Except where mandated by applicable law, testing of all parameters of each component is not necessarily performed.

TI assumes no liability for applications assistance or the design of Buyers' products. Buyers are responsible for their products and applications using TI components. To minimize the risks associated with Buyers' products and applications, Buyers should provide adequate design and operating safeguards.

TI does not warrant or represent that any license, either express or implied, is granted under any patent right, copyright, mask work right, or other intellectual property right relating to any combination, machine, or process in which TI components or services are used. Information published by TI regarding third-party products or services does not constitute a license to use such products or services or a warranty or endorsement thereof. Use of such information may require a license from a third party under the patents or other intellectual property of the third party, or a license from TI under the patents or other intellectual property of TI.

Reproduction of significant portions of TI information in TI data books or data sheets is permissible only if reproduction is without alteration and is accompanied by all associated warranties, conditions, limitations, and notices. TI is not responsible or liable for such altered documentation. Information of third parties may be subject to additional restrictions.

Resale of TI components or services with statements different from or beyond the parameters stated by TI for that component or service voids all express and any implied warranties for the associated TI component or service and is an unfair and deceptive business practice. TI is not responsible or liable for any such statements.

Buyer acknowledges and agrees that it is solely responsible for compliance with all legal, regulatory and safety-related requirements concerning its products, and any use of TI components in its applications, notwithstanding any applications-related information or support that may be provided by TI. Buyer represents and agrees that it has all the necessary expertise to create and implement safeguards which anticipate dangerous consequences of failures, monitor failures and their consequences, lessen the likelihood of failures that might cause harm and take appropriate remedial actions. Buyer will fully indemnify TI and its representatives against any damages arising out of the use of any TI components in safety-critical applications.

In some cases, TI components may be promoted specifically to facilitate safety-related applications. With such components, TI's goal is to help enable customers to design and create their own end-product solutions that meet applicable functional safety standards and requirements. Nonetheless, such components are subject to these terms.

No TI components are authorized for use in FDA Class III (or similar life-critical medical equipment) unless authorized officers of the parties have executed a special agreement specifically governing such use.

Only those TI components which TI has specifically designated as military grade or "enhanced plastic" are designed and intended for use in military/aerospace applications or environments. Buyer acknowledges and agrees that any military or aerospace use of TI components which have **not** been so designated is solely at the Buyer's risk, and that Buyer is solely responsible for compliance with all legal and regulatory requirements in connection with such use.

TI has specifically designated certain components as meeting ISO/TS16949 requirements, mainly for automotive use. In any case of use of non-designated products, TI will not be responsible for any failure to meet ISO/TS16949.

### Products

Audio	<a href="http://www.ti.com/audio">www.ti.com/audio</a>
Amplifiers	<a href="http://amplifier.ti.com">amplifier.ti.com</a>
Data Converters	<a href="http://dataconverter.ti.com">dataconverter.ti.com</a>
DLP® Products	<a href="http://www.dlp.com">www.dlp.com</a>
DSP	<a href="http://dsp.ti.com">dsp.ti.com</a>
Clocks and Timers	<a href="http://www.ti.com/clocks">www.ti.com/clocks</a>
Interface	<a href="http://interface.ti.com">interface.ti.com</a>
Logic	<a href="http://logic.ti.com">logic.ti.com</a>
Power Mgmt	<a href="http://power.ti.com">power.ti.com</a>
Microcontrollers	<a href="http://microcontroller.ti.com">microcontroller.ti.com</a>
RFID	<a href="http://www.ti-rfid.com">www.ti-rfid.com</a>
OMAP Applications Processors	<a href="http://www.ti.com/omap">www.ti.com/omap</a>
Wireless Connectivity	<a href="http://www.ti.com/wirelessconnectivity">www.ti.com/wirelessconnectivity</a>

### Applications

Automotive and Transportation	<a href="http://www.ti.com/automotive">www.ti.com/automotive</a>
Communications and Telecom	<a href="http://www.ti.com/communications">www.ti.com/communications</a>
Computers and Peripherals	<a href="http://www.ti.com/computers">www.ti.com/computers</a>
Consumer Electronics	<a href="http://www.ti.com/consumer-apps">www.ti.com/consumer-apps</a>
Energy and Lighting	<a href="http://www.ti.com/energy">www.ti.com/energy</a>
Industrial	<a href="http://www.ti.com/industrial">www.ti.com/industrial</a>
Medical	<a href="http://www.ti.com/medical">www.ti.com/medical</a>
Security	<a href="http://www.ti.com/security">www.ti.com/security</a>
Space, Avionics and Defense	<a href="http://www.ti.com/space-avionics-defense">www.ti.com/space-avionics-defense</a>
Video and Imaging	<a href="http://www.ti.com/video">www.ti.com/video</a>

### TI E2E Community

[e2e.ti.com](http://e2e.ti.com)