

POWER STAGE @ top side

Revision History	
Revision	Notes
A	*** PRELIMINARY *** added gate resistor, changed dual inductor
B	

- * dual inductor MSD-1514-473 has been modified:
- * changed crossed pin out to parallel for layout reasons
- * increased leakage inductance to reduce circulating currents, LL=17uH

CONTROLLER @ bottom side

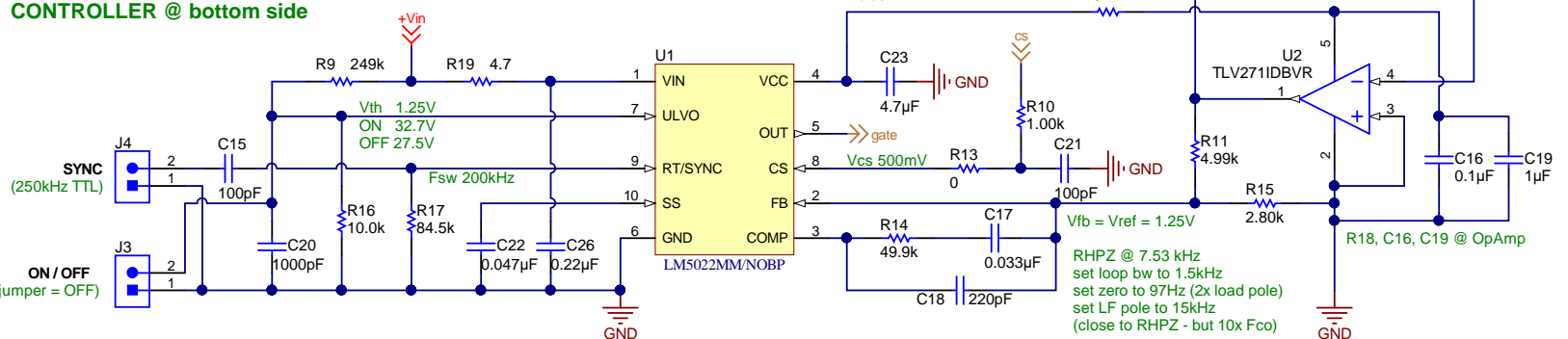

NOTES:

- 1) R1 for test purposes only
- 2) all calculations done for +36V input voltage
- 3) MSD1514 series from stock has been replaced by custom YA9010-BE

low noise 50W+ Cuk converter

Orderable:	Designed for: Public Release	Mod. Date: 12/7/2018
TID #:	Project Title: inverting SEPIC for sensitive loads	
Number: PMP30487	Rev: A	Sheet Title:
SVN Rev: Not in version control	Assembly Variant: [No Variations]	Sheet: 1 of 1
Drawn By:	File: PMP30487RevB_SchDoc	Size: A4
Engineer: B. Geck	Contact: http://www.ti.com/support	



IMPORTANT NOTICE AND DISCLAIMER

TI PROVIDES TECHNICAL AND RELIABILITY DATA (INCLUDING DATASHEETS), DESIGN RESOURCES (INCLUDING REFERENCE DESIGNS), APPLICATION OR OTHER DESIGN ADVICE, WEB TOOLS, SAFETY INFORMATION, AND OTHER RESOURCES "AS IS" AND WITH ALL FAULTS, AND DISCLAIMS ALL WARRANTIES, EXPRESS AND IMPLIED, INCLUDING WITHOUT LIMITATION ANY IMPLIED WARRANTIES OF MERCHANTABILITY, FITNESS FOR A PARTICULAR PURPOSE OR NON-INFRINGEMENT OF THIRD PARTY INTELLECTUAL PROPERTY RIGHTS.

These resources are intended for skilled developers designing with TI products. You are solely responsible for (1) selecting the appropriate TI products for your application, (2) designing, validating and testing your application, and (3) ensuring your application meets applicable standards, and any other safety, security, or other requirements. These resources are subject to change without notice. TI grants you permission to use these resources only for development of an application that uses the TI products described in the resource. Other reproduction and display of these resources is prohibited. No license is granted to any other TI intellectual property right or to any third party intellectual property right. TI disclaims responsibility for, and you will fully indemnify TI and its representatives against, any claims, damages, costs, losses, and liabilities arising out of your use of these resources.

TI's products are provided subject to TI's Terms of Sale (www.ti.com/legal/termsofsale.html) or other applicable terms available either on ti.com or provided in conjunction with such TI products. TI's provision of these resources does not expand or otherwise alter TI's applicable warranties or warranty disclaimers for TI products.

Mailing Address: Texas Instruments, Post Office Box 655303, Dallas, Texas 75265
Copyright © 2018, Texas Instruments Incorporated