

Single-Ended Input Pop Reduction for TPA6203A1

Jinggui Nie

AIP - Portable Audio Amplifiers

ABSTRACT

TPA6203A1, with high PSRR, improved RF-rectification immunity, and small PCB area makes it an ideal audio power amplifier for portable product application. These portable products may include handsets, CMMB, GPS, and PMP.

One phenomenon of TPA6203A1, in single-ended (SE) input configuration, is the undesirable audible pop when cycling in and out of shutdown quickly. This application report describes a method to reduce the audible pop, present lab results, and discusses tradeoffs to consider for the implementation.

1 Introduction

TPA6203A1 is a fully differential amplifier with integrated de-pop circuitry; however, in a SE input configuration, an audible pop can occur when TPA6203A1 is cycled in and out of shutdown quickly. This is especially true if the impedance of the audio input paths are not well matched and if there is insufficient time in shutdown to discharge the input capacitors. This application report explains the cause of pop and describes a method to reduce this pop and is applicable to similar TPA62xx devices, such as TPA6204A1 and TPA6205A1.

Figure 1 is a typical implementation of TPA6203A1 as a SE input amplifier in a portable application. The red arrow line is the discharge path for IN+ input, the blue one is for IN– input. In this case, the impedance of the audio input paths are not well matched since IN+ terminates to GND after C3 while IN– terminates into HPLCOM after C1. HPLCOM is in a high impedance state when TLV320DAC32 is in a standby state.

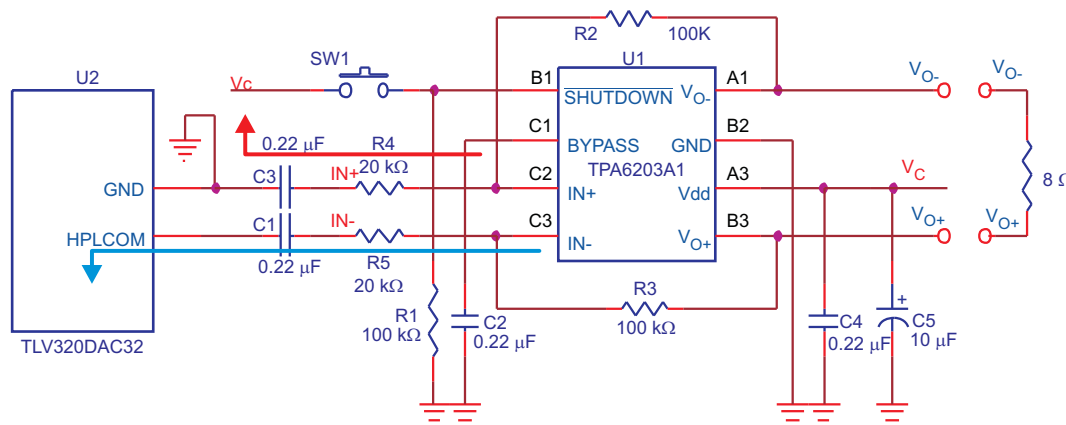

Figure 1. TPA6203A1 in SE Configuration

2 Cause of Pop in TPA6203A1 in SE Input Configuration

During TPA6203A1 normal operation, the input and output terminals are biased to $V_{dd}/2$. When shutdown is asserted, both input and output bias voltages begin to discharge from $V_{dd}/2$ to 0V. If IN+ and IN– input impedance paths are well matched, the discharge slope and time between IN+ and IN– input paths will be

very similar and there will be no audible pop even when TPA6203A1 is cycled in and out of shutdown quickly. In real application, such as interfacing with the TLV320DAC32, the output impedance of TLV320DAC32 and tolerance of discrete components can result in impedance mismatch between two differential inputs. The different discharge slopes between IN+ and IN- paths can produce an audible pop. This pop can be reduced if there is sufficient time for both input capacitors to discharge completely.

Figure 2 is the voltages of IN+ and IN- when cycling in and out of shutdown with sufficient time (about 4 seconds) for both input capacitors to discharge completely. Trace 1 is Shutdown, Trace 2 is Vo+, Trace 3 is Vin+, Trace 4 is VIN-. No transient signal or audible pop is observed.

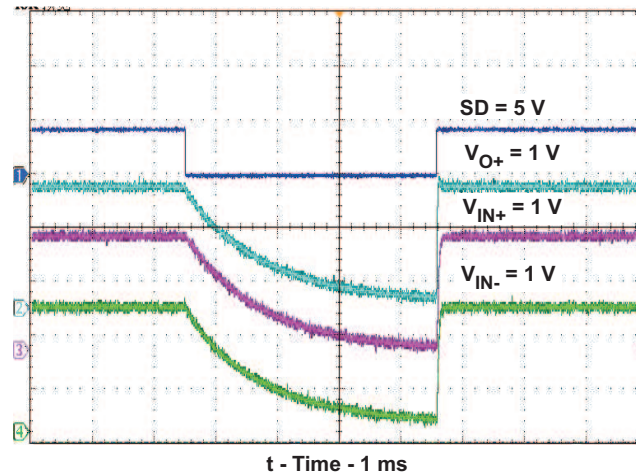

Figure 2. Four Seconds Discharge Time for Input and Output Bias Voltage

In most portable applications for example, the play, pause, or key button tones for music devices may be operated before the capacitor discharge time. An audible pop can occur, as shown in Figure 3, if there is insufficient time to completely discharge the capacitors (400ms discharge time), a transient signal is observed.

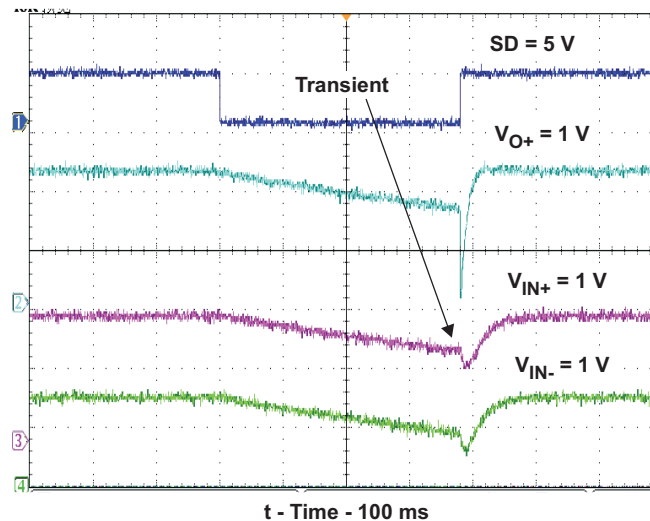

Figure 3. The Transient Signal Happened With Insufficient Discharge Time

Changing the Bypass capacitor has little effect reducing the pop as it has little effect in discharging Vin-. Figure 4 and Figure 5 are the captures with 0.22μF and 2.2μF Bypass capacitor respectively.

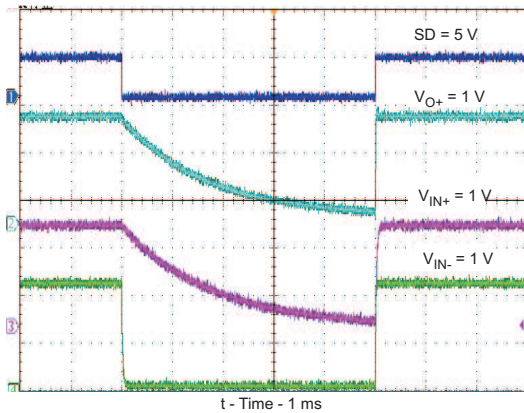

Figure 4. 0.22 μF Bypass Capacitor

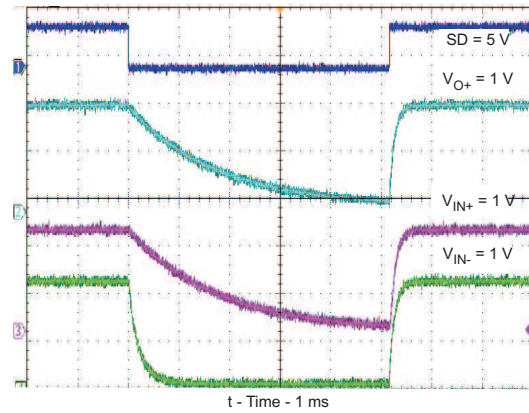

Figure 5. 2.2 μF Bypass Capacitor

3 Reducing the Pop

Adding resistors R6 and R7 shown in Figure 6 provides an additional path to discharge the input capacitors. This shortens the discharge time to about 100ms and reduces the audible pop. The red dotted line is the additional discharge path for IN+ and the blue dotted line is for IN-.

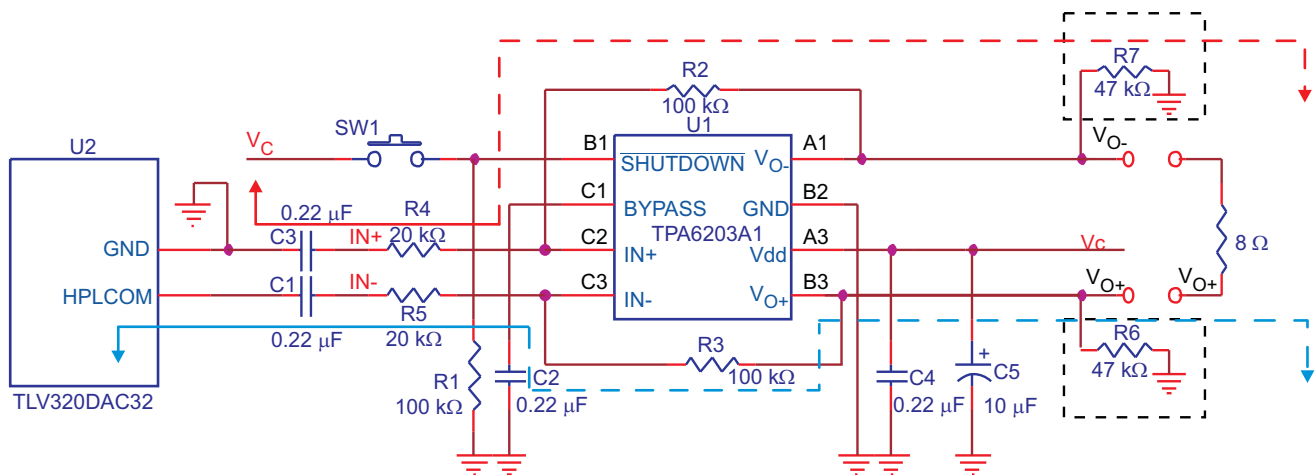

Figure 6. Additional Discharge Paths for Bias Voltage

Figure 7 is the oscilloscope capture of the discharge time with R6 and R7 connected. With a shutdown time as low as 130ms, no transient signal or audible pop are observed.

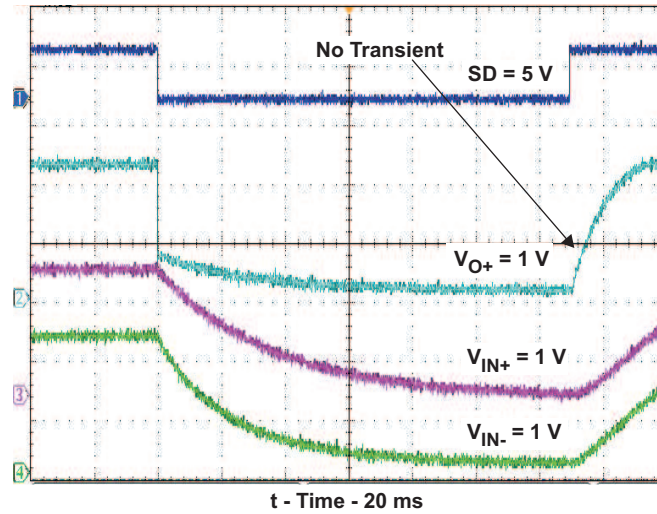

Figure 7. The Shortened Discharge Time

Figure 8 and Figure 9 compare the pop before and after implementing the solution.

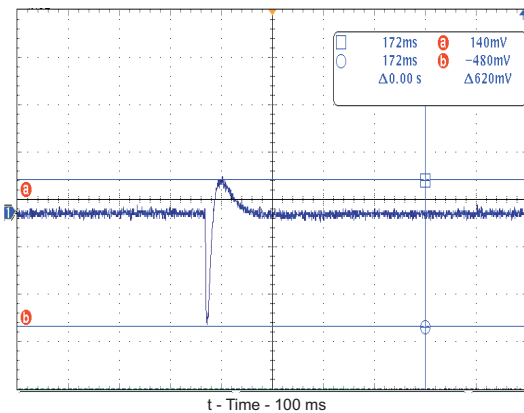

Figure 8. Pop Before the Solution

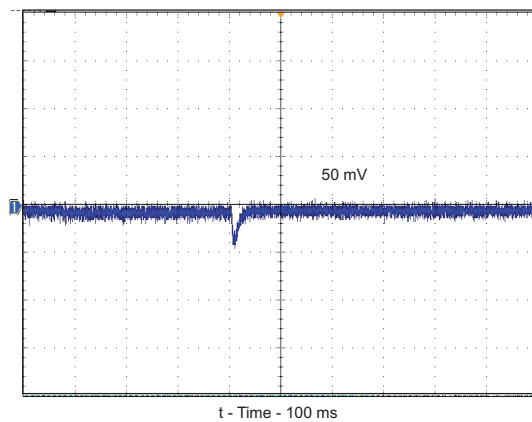

Figure 9. Pop After the Solution

4 Tradeoffs

One tradeoff of this solution is slightly higher quiescent current added in normal operation mode.

$$I_q = 2 \times (\text{output bias voltage} / R) \tag{1}$$

The factor of 2 is due to two legs of BTL output.

For 4.2V power supply, the output bias voltage is 2.1V. Substituting it to Equation 1:

$$I_q = 2 \times (2.1V / 47K) = 89.4\mu A \tag{2}$$

The power dissipation added is

$$P_{diss} = \text{Power supply} \times I_q = 4.2V \times 89.4\mu A = 375\mu W \tag{3}$$

This power dissipation is negligible compared to the maximum output power (1.25W) of TPA6203A1.

5 Audio Performance Test

The TPA6203A1 audible pop solution presented in this document does not degrade its overall performance. Figure 10 is THD+N vs output power and Figure 11 is THD+N vs Frequency. Trace 1(Green) is tested in the circuit before the solution and Trace 2(Yellow) is after the solution. The test conditions is as follow:

- $V_C = 4V$, $R_{LOAD} = 8\ \Omega$, Gain = 5 V/V.
- $C_{bypass} = 0.22\mu F$ (C2 in Figure 6), input capacitor = $0.22\mu F$ (C1 and C3 in Figure 6).
- Input signal frequency = 1kHz

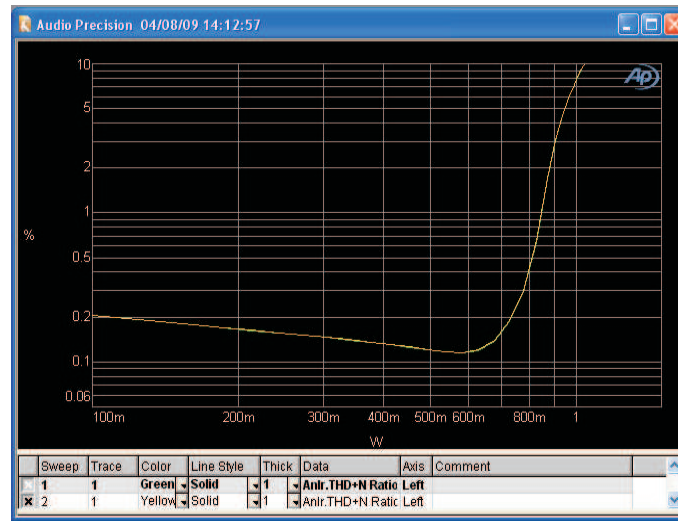

Figure 10. THD+N vs Output Power Sweep, $R_{load} = 8\ \Omega$, $V_{dd} = 4V$, Input Frequency = 1kHz

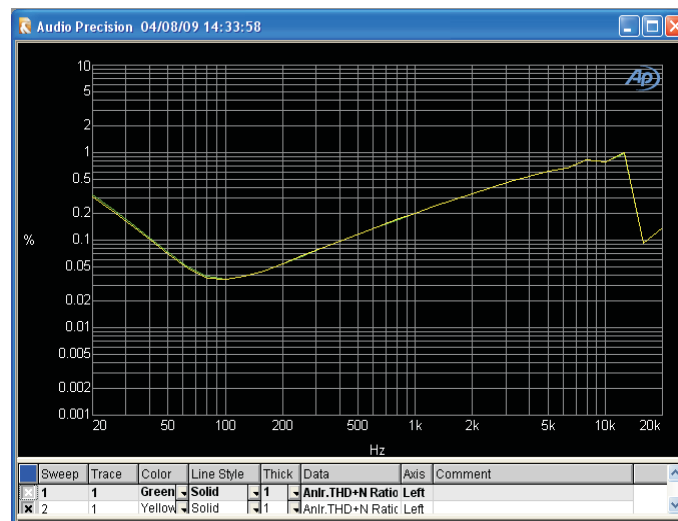

Figure 11. THD+N vs Frequency Sweep, $R_{load} = 8\ \Omega$, $V_{dd} = 4V$, Output Power = 1 W

6 Conclusion

This Application Note presents the cause of audible pop in TPA6203A1 in a single-ended input configuration when cycled in and out of shutdown quickly. Adding two resistors at the output terminals reduces the discharge time and audible pop. The tradeoff of the solution is a slight increase in power dissipation.

7 References

1. TPA6203A1: 1.25W Mono Fully Differential Audio Power Amplifier data sheet ([SLOS364F](#))
2. TPA6203A1EVM Board User Guide ([SLOU123A](#))

IMPORTANT NOTICE

Texas Instruments Incorporated and its subsidiaries (TI) reserve the right to make corrections, modifications, enhancements, improvements, and other changes to its products and services at any time and to discontinue any product or service without notice. Customers should obtain the latest relevant information before placing orders and should verify that such information is current and complete. All products are sold subject to TI's terms and conditions of sale supplied at the time of order acknowledgment.

TI warrants performance of its hardware products to the specifications applicable at the time of sale in accordance with TI's standard warranty. Testing and other quality control techniques are used to the extent TI deems necessary to support this warranty. Except where mandated by government requirements, testing of all parameters of each product is not necessarily performed.

TI assumes no liability for applications assistance or customer product design. Customers are responsible for their products and applications using TI components. To minimize the risks associated with customer products and applications, customers should provide adequate design and operating safeguards.

TI does not warrant or represent that any license, either express or implied, is granted under any TI patent right, copyright, mask work right, or other TI intellectual property right relating to any combination, machine, or process in which TI products or services are used. Information published by TI regarding third-party products or services does not constitute a license from TI to use such products or services or a warranty or endorsement thereof. Use of such information may require a license from a third party under the patents or other intellectual property of the third party, or a license from TI under the patents or other intellectual property of TI.

Reproduction of TI information in TI data books or data sheets is permissible only if reproduction is without alteration and is accompanied by all associated warranties, conditions, limitations, and notices. Reproduction of this information with alteration is an unfair and deceptive business practice. TI is not responsible or liable for such altered documentation. Information of third parties may be subject to additional restrictions.

Resale of TI products or services with statements different from or beyond the parameters stated by TI for that product or service voids all express and any implied warranties for the associated TI product or service and is an unfair and deceptive business practice. TI is not responsible or liable for any such statements.

TI products are not authorized for use in safety-critical applications (such as life support) where a failure of the TI product would reasonably be expected to cause severe personal injury or death, unless officers of the parties have executed an agreement specifically governing such use. Buyers represent that they have all necessary expertise in the safety and regulatory ramifications of their applications, and acknowledge and agree that they are solely responsible for all legal, regulatory and safety-related requirements concerning their products and any use of TI products in such safety-critical applications, notwithstanding any applications-related information or support that may be provided by TI. Further, Buyers must fully indemnify TI and its representatives against any damages arising out of the use of TI products in such safety-critical applications.

TI products are neither designed nor intended for use in military/aerospace applications or environments unless the TI products are specifically designated by TI as military-grade or "enhanced plastic." Only products designated by TI as military-grade meet military specifications. Buyers acknowledge and agree that any such use of TI products which TI has not designated as military-grade is solely at the Buyer's risk, and that they are solely responsible for compliance with all legal and regulatory requirements in connection with such use.

TI products are neither designed nor intended for use in automotive applications or environments unless the specific TI products are designated by TI as compliant with ISO/TS 16949 requirements. Buyers acknowledge and agree that, if they use any non-designated products in automotive applications, TI will not be responsible for any failure to meet such requirements.

Following are URLs where you can obtain information on other Texas Instruments products and application solutions:

Products

| | |
|-----------------------------|--|
| Amplifiers | amplifier.ti.com |
| Data Converters | dataconverter.ti.com |
| DLP® Products | www.dlp.com |
| DSP | dsp.ti.com |
| Clocks and Timers | www.ti.com/clocks |
| Interface | interface.ti.com |
| Logic | logic.ti.com |
| Power Mgmt | power.ti.com |
| Microcontrollers | microcontroller.ti.com |
| RFID | www.ti-rfid.com |
| RF/IF and ZigBee® Solutions | www.ti.com/lprf |

Applications

| | |
|--------------------|--|
| Audio | www.ti.com/audio |
| Automotive | www.ti.com/automotive |
| Broadband | www.ti.com/broadband |
| Digital Control | www.ti.com/digitalcontrol |
| Medical | www.ti.com/medical |
| Military | www.ti.com/military |
| Optical Networking | www.ti.com/opticalnetwork |
| Security | www.ti.com/security |
| Telephony | www.ti.com/telephony |
| Video & Imaging | www.ti.com/video |
| Wireless | www.ti.com/wireless |

Mailing Address: Texas Instruments, Post Office Box 655303, Dallas, Texas 75265
Copyright © 2009, Texas Instruments Incorporated