

# EVM User's Guide: TMP115EVM

## TMP115 Evaluation Module



### Description

The [TMP115](#) is a I2C-compatible digital temperature sensor in an ultra-small (0.72mm<sup>2</sup>) 5-pin DPW package along with 1.6mm × 1.6mm 6-pin DRL package. The TMP115 evaluation module (EVM) allows users to evaluate the performance of the TMP115 digital temperature sensor.

### Get Started

1. Order the [TMP115EVM](#)
2. Detach the sensor breakout PCB section (optional)
3. Connect the EVM to computer or user system
4. Go to the [TMP115EVM gallery page](#) on dev.ti.com to either download the GUI or run on the web
5. Refer to the [TMP115 data sheet](#) for IC details
6. Visit our [E2E forums](#) for support or questions

### Features

- Easy to use cloud-based graphical user interface (GUI) is available on the web or can be downloaded for offline use
- Showcase the ultra-small digital temperature sensor with alert functionality
- Breakable sensor board with 0.1" pitch header footprint to interface with the TMP115
- Attachable connector for flex PCB board option for temperature sensing
- Hardware selectable addressing available
- Data logging with the GUI

### Applications

- [Building automation](#)
  - [Occupancy detection](#)
  - [Video doorbell](#)
  - [HVAC: Wireless environmental sensor](#)
- [Factory automation and control](#)
  - [Machine vision camera](#)
  - [Power Delivery Units](#)
  - [Industrial PC: Single board computer](#)
  - [CPU \(PLC controller\)](#)
- [Medical equipment](#)
  - [Continuous glucose monitor](#)
- [Data center and enterprise computing](#)
  - [Solid State Drive \(SSD\)](#)
  - [Rack Server Motherboard](#)
- [Personal electronics](#)
  - [PC and notebooks, tablets](#)
  - [Digital still and video camera](#)
  - [Augmented reality glasses](#)
  - [Smart speakers](#)

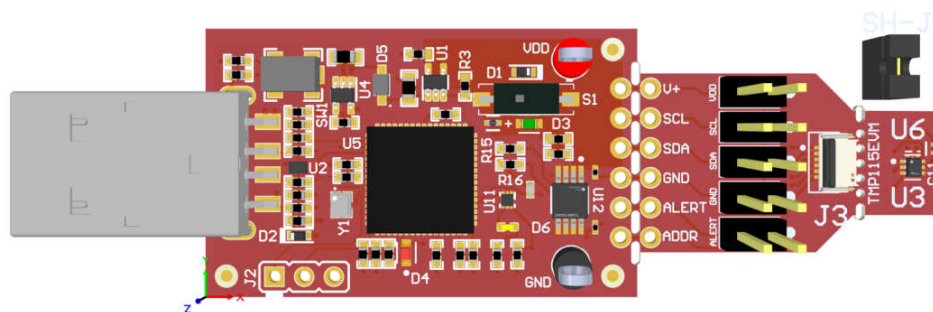

TMP115EVM

# 1 Evaluation Module Overview

## 1.1 Introduction

The TMP115EVM is designed to be used as is, along with the evaluation module graphical user interface (GUI). Alternatively, the sensor can be detached to be evaluated in the user's system. For this purpose, there are multiple alternatives to interface with the sensor for best user experience.

The EVM comes in a USB stick form factor, with an onboard MSP430F5528 microcontroller that interfaces with both the host computer and the TMP115 device using an Inter-Integrated Circuit (I2C) interface. The module is designed with perforations between the sensor and host controller on the EVM board. The perforation allows the user flexibility in the evaluation:

- The user can connect the TMP115 sensor breakout section to the user's system/host.
- The user can connect the EVM host and software to the user's system with TMP115 devices.
- Small individual boards allow the user to place sensors in the user's system or in a temperature-controlled environment to evaluate performance.
- Hole spacing is compatible with common 0.1in prototyping breadboards.

This user's guide describes the characteristics, operation, and use of the TMP115EVM evaluation board by explaining how to set up and configure the software, describing the hardware, and reviewing various aspects of the software operation. Throughout this document, the terms evaluation board, evaluation module, and EVM are synonymous with the TMP115EVM. This user's guide also provides information on the operating procedure, input and output connections, an electrical schematic, printed-circuit board (PCB) layout drawings, and a parts list for the EVM.

## 1.2 Kit Contents

The content of the EVM kit is shown below. Contact the Texas Instruments Product Information Center nearest you if any components are missing. TI highly recommends that users check the TI website at <https://www.ti.com> to verify that the latest versions of the related software is downloaded.

- 1 - TMP115EVM
- 1 - Header, 100mil, 3×1, Gold, TH

## 1.3 Specification

[Table 1-1](#) defines the absolute maximum thermal conditions of each section of the EVM. The main 2 sections are the controller section and the sensor breakout section. These limits must be considered when evaluating the performance of the device at extreme temperatures. In this case, if the setup conditions exceed the controller absolute maximum thermal specifications, then the sensor breakout section must be detached so that only the sensor (and not the MCU) is evaluated at these temperatures.

**Table 1-1. Thermal Specifications**

BOARD SECTION	CONDITIONS	TEMPERATURE RANGE
Controller board	Recommended operating free-air temperature, $T_A$	-40°C to 85°C
	Absolute maximum junction temperature, $T_J$	95°C
TMP115 breakout section	Recommended operating free-air temperature, $T_A$	-55°C to 175°C

## 1.4 Device Information

The TMP115 is a digital output temperature sensor that is calibrated in production to achieve high accuracy in a small 6-pin WCSP package. This device communicates in a two-wire environment compatible with SMBus and I<sup>2</sup>C interfaces, and has 4 I<sup>2</sup>C address options using the address select pin. The device can be set to make continuous or one-shot conversions and additionally has alert functionality. For more information of the IC, please refer to the device data sheet.

## 2 Hardware

### 2.1 Overview

The EVM is divided into two sections: the controller section and the sensor breakout section. The sensor breakout section can be detached to use the sensor in the following scenarios:

- Using the controller section with the sensor section connected by soldered wires or connectors to evaluate the sensor far from the controller and PC at extreme temperatures or other conditions.
- Using the sensor section with the user's system by interfacing through I<sup>2</sup>C with the TMP115.
- Using the controller section with TMP115 sensors in the user's system.

[TMP115EVM Board Sections](#) highlights the EVM sections as well as some components that must be identified by the user to understand the purpose and use. The components are further explained in detail in the sections below.

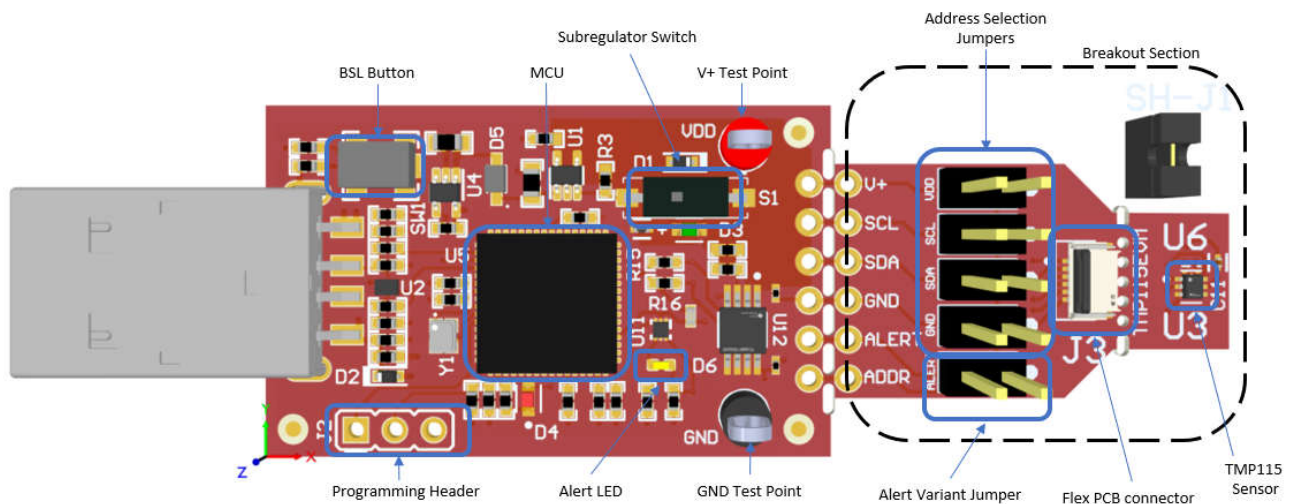

Figure 2-1. TMP115EVM Board Sections

### 2.2 Perforations and Connectivity

The perforation between the USB controller and TMP115 sensor breakout section is labeled on the bottom of the board on both sides for pin connections. Once the sensor section is detached from the controller section, the user can interface with the sensor section by soldering wires or 0.1in header connectors. With this approach, the user has access to all 6 pins of the device.

Note that pullup resistors and protection diodes are on the controller section. Thus, when interfacing with other controller boards, TI recommends to verify that pullup resistors and protection circuitry are present on any controller board for safe and proper functionality.

Additionally, the EVM configuration allows for different address selection through a jumper. The DPW package has either an alert or address variant. Depending on the DPW variant, you can select either an address or alert with a jumper as shown in [Figure 2-1](#). This configuration allows you access to the GUI features while changing the device to a DPW package on the EVM.

The TMP115EVM has the option to connect a flex PCB with an attached TMP115. The TMP115 flex PCB connection has a different orderable online and needs to be ordered separately. Either the default FR-4 breakable section can be connect or the flex PCB can be connected. Both cannot be connected to the USB at the same time.

### 2.3 Status LEDs and Sub-regulator

The green LED D3 illuminates when VDD is supplied. VDD must be supplied for normal operation of the TMP115EVM as VDD is used for device power and communication line pullup voltages. VDD can be supplied via the on-board sub-regulator U1 or external power. See [Section 2.5](#) for more details.

The yellow LED D6 illuminates when the ALERT pin is low. The default software configuration of the ALERT pin is active-low, and the LED illuminates when ALERT becomes active or "trips".

The red LED D4 is the MSP430F5528 status LED. [Table 2-1](#) shows how the different modes of operation are displayed by the LED status.

**Table 2-1. Status LED Mode of Operation**

D4 LED STATUS	MSP430F5528 MODE OF OPERATION
Off	EVM is connected to EVM GUI
Blinking in bursts of 4 blinks	EVM is plugged into PC, not connected to EVM GUI
Steady blinking	Connected to USB power

### 2.4 Address Selection

The TMP115EVM has an Address Selection portion of the breakout section. The jumper can be moved to ALERT, GND, SDA, SCL, or VDD for address selection. Refer to the datasheet to understand what I2C address your device is configured to. Take care to only install 1 jumper at a time to avoid shorts. Depending on the DPW variant, you can select either an address or alert with a jumper. This configuration allows you access to the GUI features while changing the device to a DPW package on the EVM.

## 2.5 Power Supply

VDD supplies power to the TMP115 device and pullup voltage of the communication lines. The supply range is listed in the datasheet. The on-board regulator U1 regulates USB power down to 3.3V. The user can also disable the sub-regulator to apply a different supply voltage. To use an external power supply, follow these instructions:

1. Flip the switch S1 to disable the sub-regulator; the green LED D3 turns off
2. Connect the external power supply using the V+ and GND test points, or by soldering headers or wires on the breakout section
3. Supply VDD; the green LED D3 turns on
4. Use the GUI as normal

## 2.6 Programming Header

The TMP115EVM comes pre-loaded with firmware that is necessary for the correct operation of the USB interface and PC GUI software. The unpopulated header, J2, is provided for Spy-Bi-Wire access to the MSP430F5528. TI does not recommend that users access this header or reprogram the device.

## 2.7 BSL Button

The TMP115EVM features push-button SW1 for entering USB BSL mode. This can be used for firmware updates. To enter USB BSL mode, connect the EVM to a PC USB port while holding down SW1.

## 3 Software

### 3.1 Software Download

The PC GUI Software for TMP115EVM runs on TI's GUI Composer framework. The software is available as a live version which runs in your browser, and is available as a download for offline use. The software is compatible with Windows®, Mac®, and Linux® operating systems.

#### 3.1.1 Live Software on *dev.ti.com*

The live software currently works on Chrome, Firefox, and Safari browsers. Internet Explorer is not supported. Users can access the live version through one of the following actions:

- Go to the EVM tool page and click on the View button
- Go to <https://dev.ti.com/gallery/search/tmp115>

Click on the application icon within the gallery to launch the software. Click on the prompt to install the TI Cloud Agent Bridge browser plugin.

### 3.1.2 Offline Software

#### 3.1.2.1 Download From dev.ti.com

Users can access the latest version of the offline software by navigating to the live version as noted above. Look for the download icon  and download both the application and runtime for the operating system as shown in the Gallery Download.

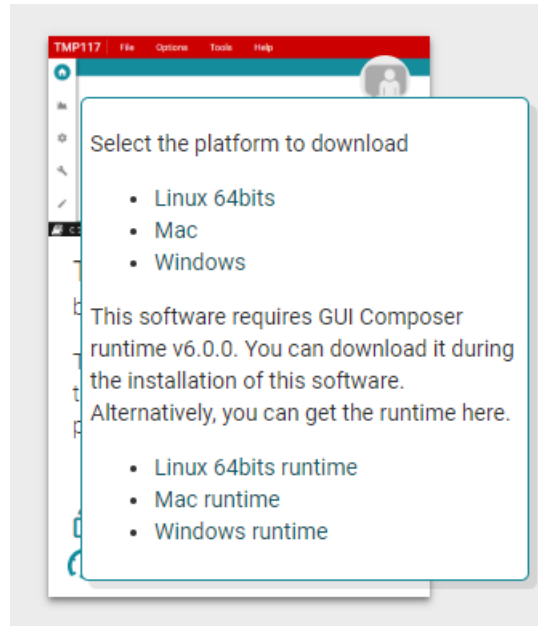

**Figure 3-1. Download Pop-Up**

### 3.2 Home Tab

The Home Tab is shown at software launch. From here, you can access the Getting Started, Information, Data, Registers and Collateral tabs which are explained below. The icons on the left side of the screen are shortcuts to the tabs.

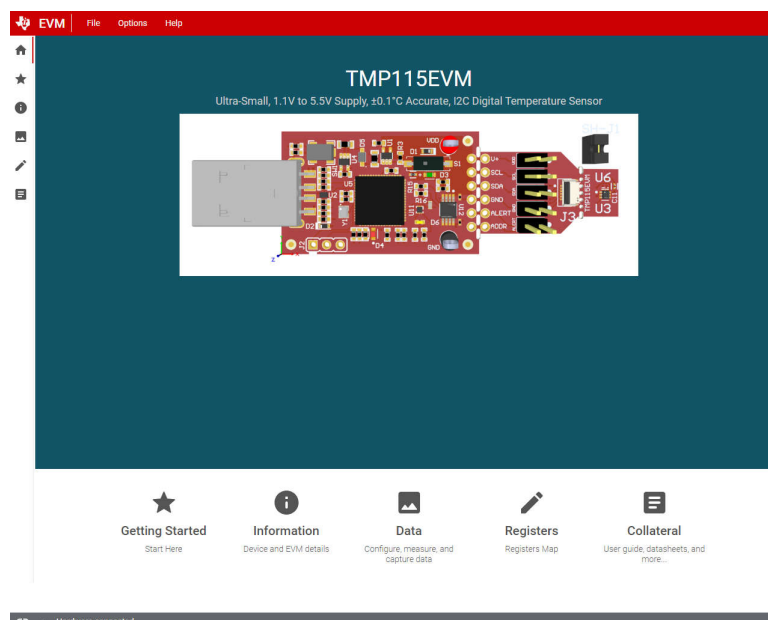

**Figure 3-2. Home**

### 3.3 Getting Started

The Getting Started tab is used to set the target I<sup>2</sup>C address based on the ADDR pin connection. The default setting assumes that the ADDR pin is connected to GND. To change the I<sup>2</sup>C configuration, make the appropriate selection from the dropdown list. Then, click the button on the bottom left of the GUI to reinitialize communication.

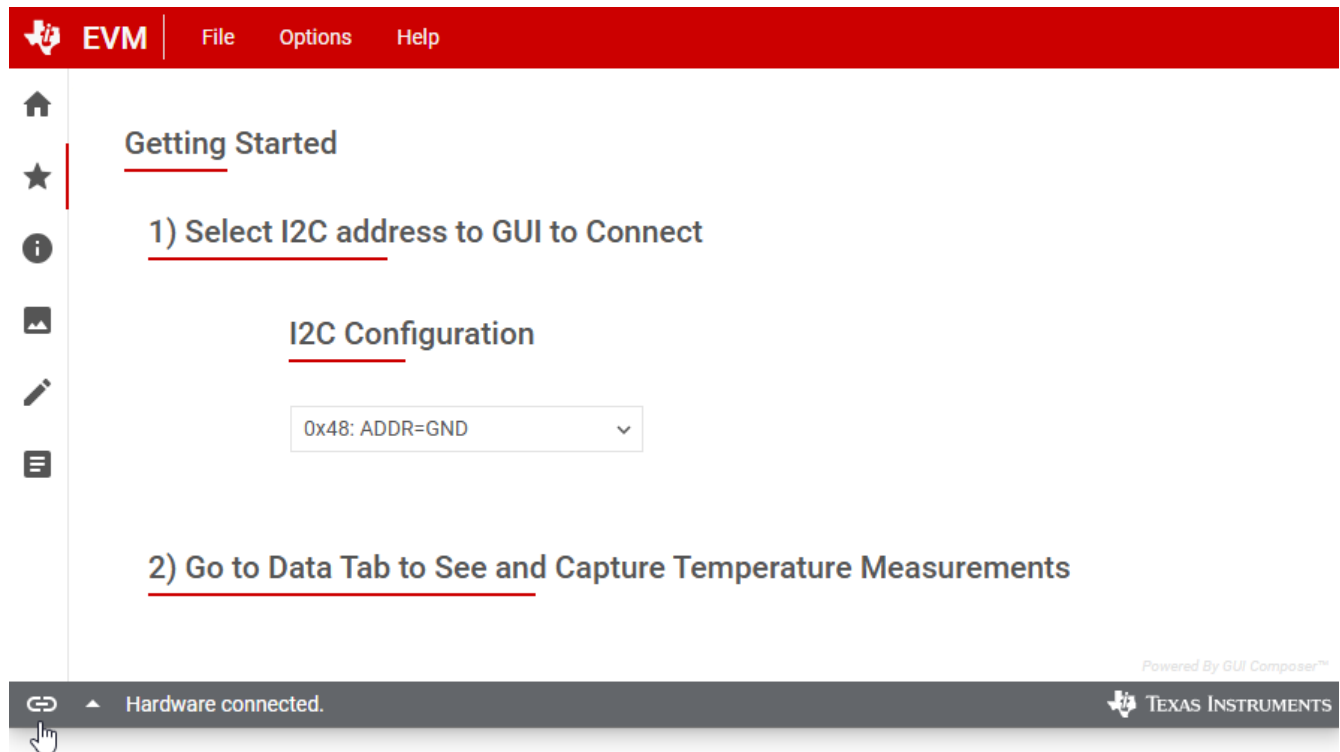

**Figure 3-3. Getting Started**

### 3.4 Information Tab

The Information tab shows device details and features of the TMP115 and EVM. The Device Information & Features sub-tab includes a specifications summary, device block diagram, and description of functional modes. The EVM Details sub-tab includes the EVM schematic and legend.

### 3.5 Data Tab

The Data Capture tab reports the temperature from the TMP115 device included on the TMP115EVM. By default, once the EVM is connected and the GUI is loaded and running properly, the device starts in continuous conversion mode and the MCU starts polling the device. The conversion results are automatically reported and displayed in the Data tab graph.

On the right side of this tab, the user can view the latest temperature read value. There is also a chart controls box which allows the user to:

- Set the polling rate. Once a value is selected from the dropdown, the MCU automatically starts reading the TMP115 at the set polling rate.
- Write to the Conversion Rate bits using the Device Rate field. Once a value is selected from the dropdown, the MCU automatically writes to the TMP115, which then starts converting at the programmed rate.
- Start and stop polling the data read to export to CSV format for temperature monitoring. The user must start polling by clicking the Start button and the data (CSV) automatically exports once the stop button is clicked.

The Alert Config box allows the user to easily configure the alert functionality settings of the TMP115 such as polarity, mode, and limits. The limits can be written on the left box in decimal format, and the corresponding hexadecimal value is automatically displayed in the right box for reference. Once selected or updated, all of the settings are written automatically to the TMP115 by the MCU.

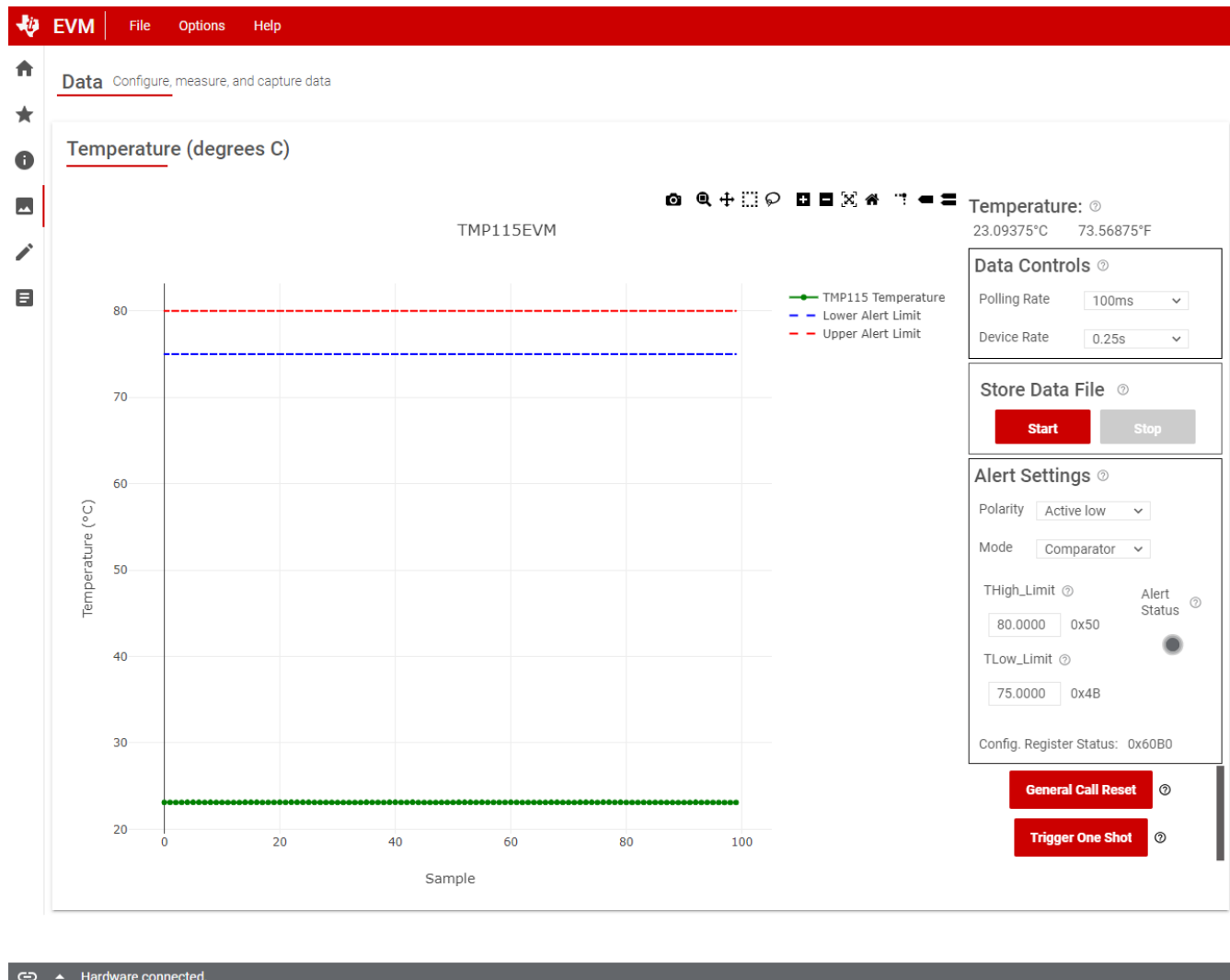

Figure 3-4. Data Capture

### 3.6 Registers Tab

The Registers tab interacts with the registers and bits within the TMP115 device. For more information on each register or bit, select on a register name to see what each bit defines.

The Auto Read dropdown box configures the polling rate of the register contents. By default, the MCU polls the registers with a 100ms delay. When Auto Read is Off, select Read Register to fetch the contents of the selected register. Read All Registers can be used to fetch the contents of all registers at once.

By default, the Write Register button is grayed and disabled when the Write Mode button is set to Immediate. Immediate mode triggers a Write operation each time a register is modified. When Deferred mode is selected, the Write Register button is enabled, and write operations are not performed unless the Write Register button is clicked.

These settings give the user total control over I<sup>2</sup>C Bus activity, and enable individual transactions to be easily observed with an oscilloscope, logic analyzer, or bus-sniffing device.

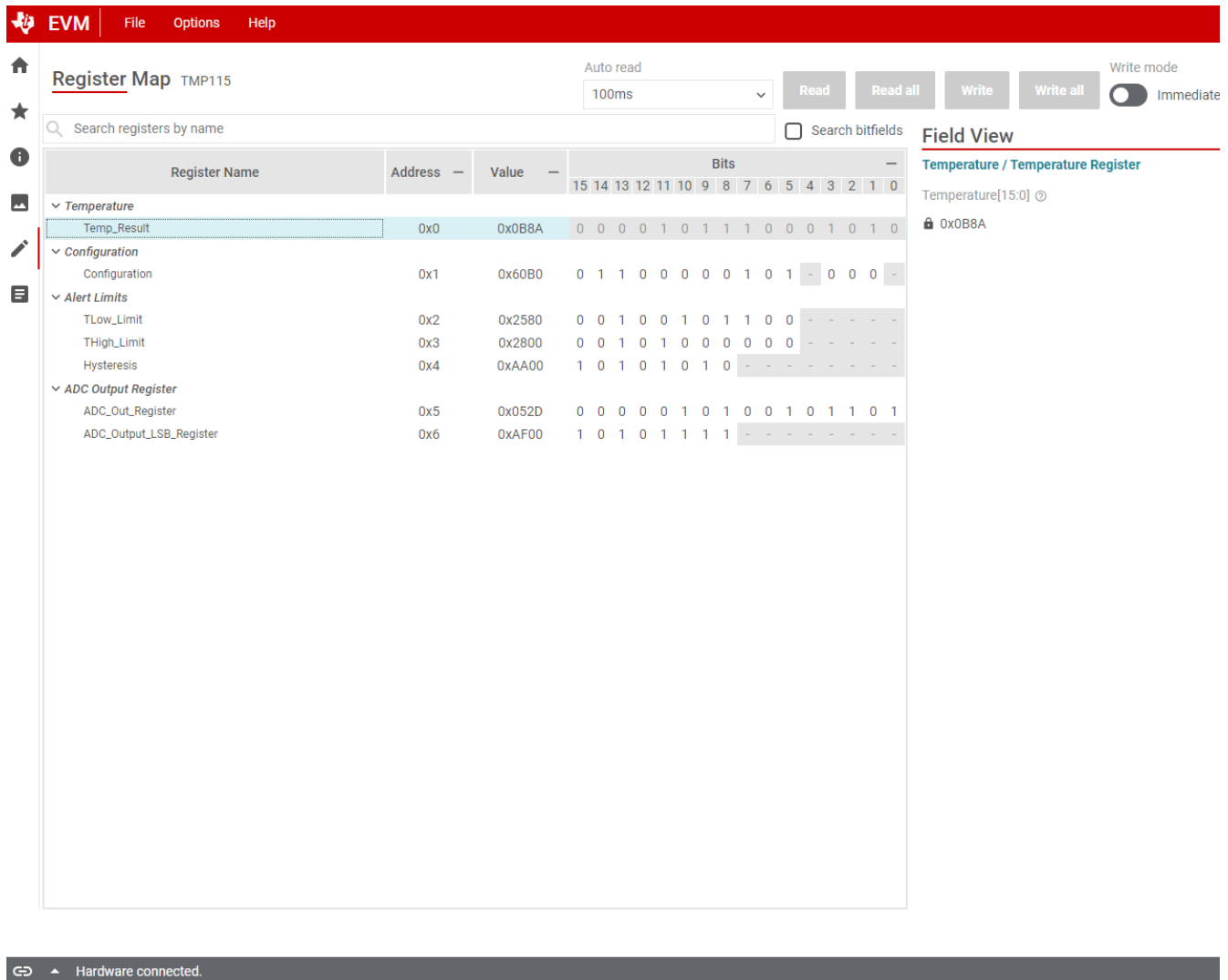

**Register Map** TMP115

Auto read: 100ms

Buttons: Read, Read all, Write, Write all

Write mode:  Immediate

Search registers by name

Register Name	Address	Value	Bits															
			15	14	13	12	11	10	9	8	7	6	5	4	3	2	1	0
Temperature																		
Temp_Result	0x0	0x0B8A	0	0	0	0	1	0	1	1	1	0	0	0	1	0	1	0
Configuration																		
Configuration	0x1	0x60B0	0	1	1	0	0	0	0	0	1	0	1	-	0	0	0	-
Alert Limits																		
TLow_Limit	0x2	0x2580	0	0	1	0	0	1	0	1	1	0	0	-	-	-	-	-
THigh_Limit	0x3	0x2800	0	0	1	0	1	0	0	0	0	0	0	-	-	-	-	-
Hysteresis	0x4	0xAA00	1	0	1	0	1	0	1	0	0	-	-	-	-	-	-	-
ADC Output Register																		
ADC_Out_Register	0x5	0x052D	0	0	0	0	0	1	0	1	0	0	1	0	1	1	0	1
ADC_Output_LSB_Register	0x6	0xAF00	1	0	1	0	1	1	1	1	-	-	-	-	-	-	-	-

**Field View**

Temperature / Temperature Register

Temperature[15:0] ⓘ

0x0B8A

Hardware connected.

Figure 3-5. Registers

### 3.7 Collateral Tab

The Collateral tab contains links to the EVM user's guide, the tool page on ti.com, as well as links to the product data sheet and other relevant links.

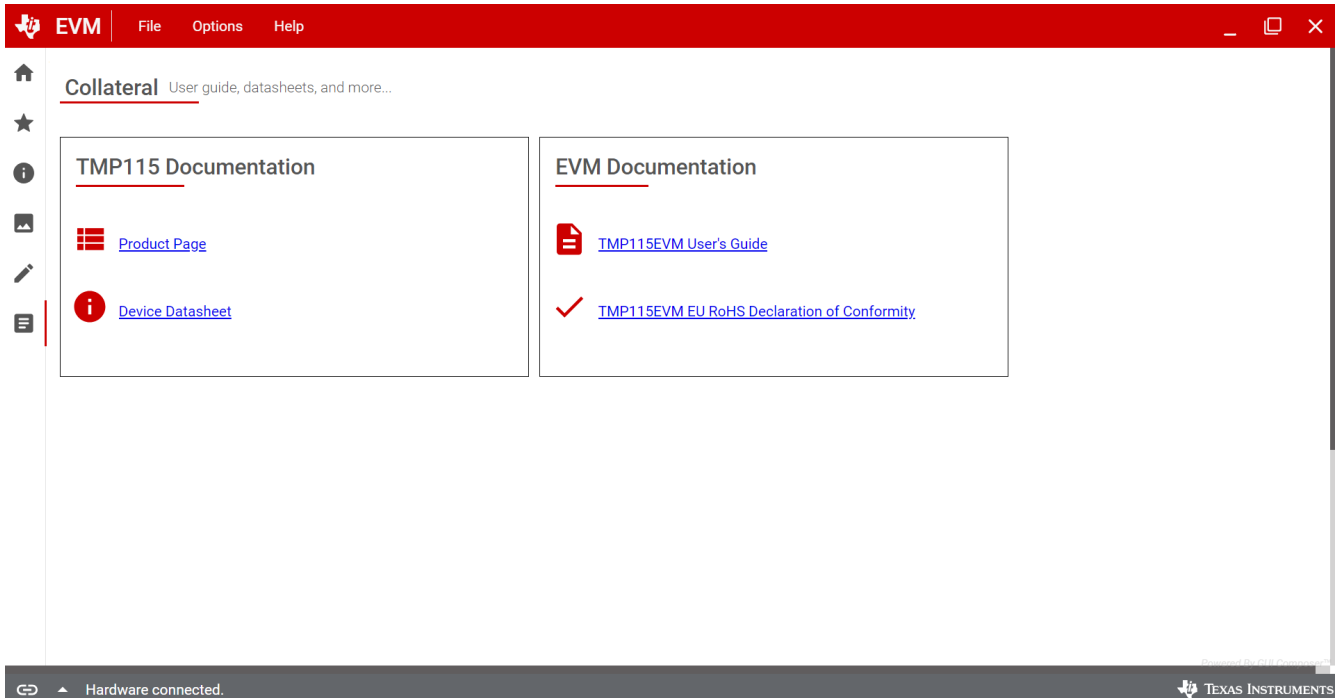

Figure 3-6. Collateral

## 4 Hardware Design Files

### 4.1 Schematic

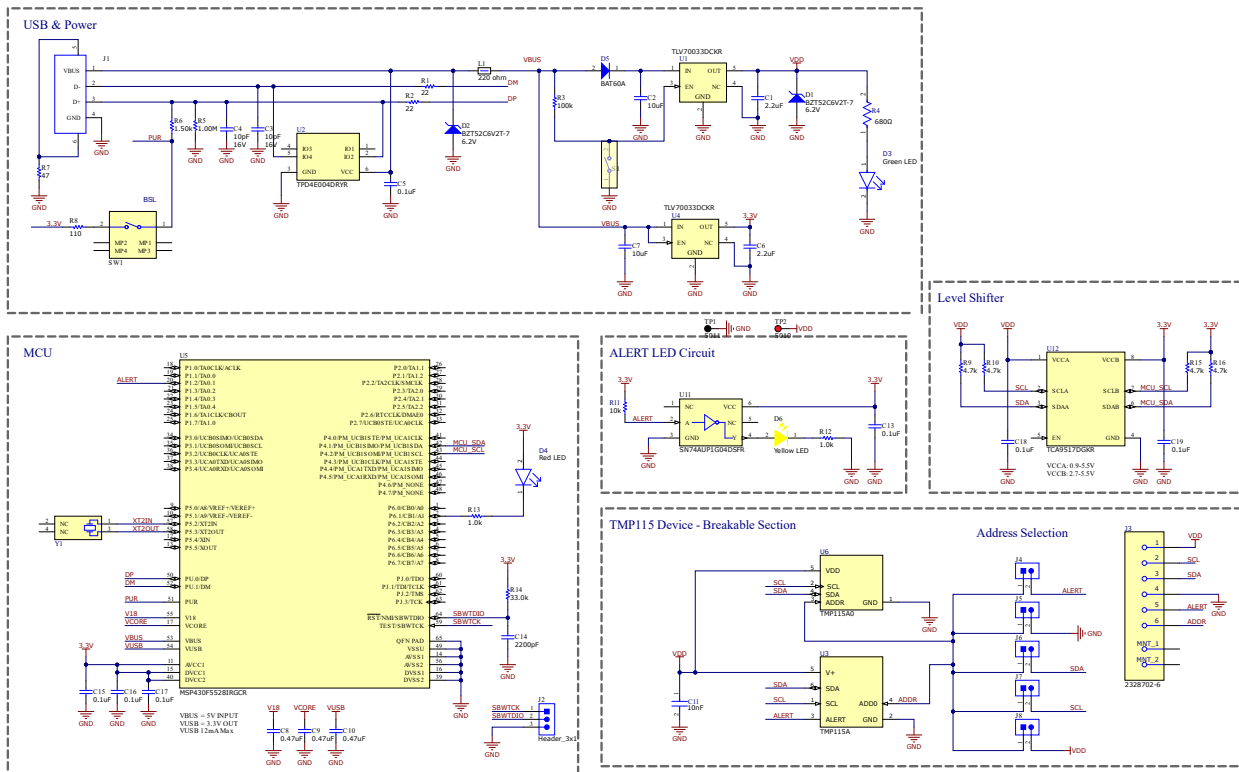

Figure 4-1. Schematic

## 4.2 PCB Layouts

SH-J1

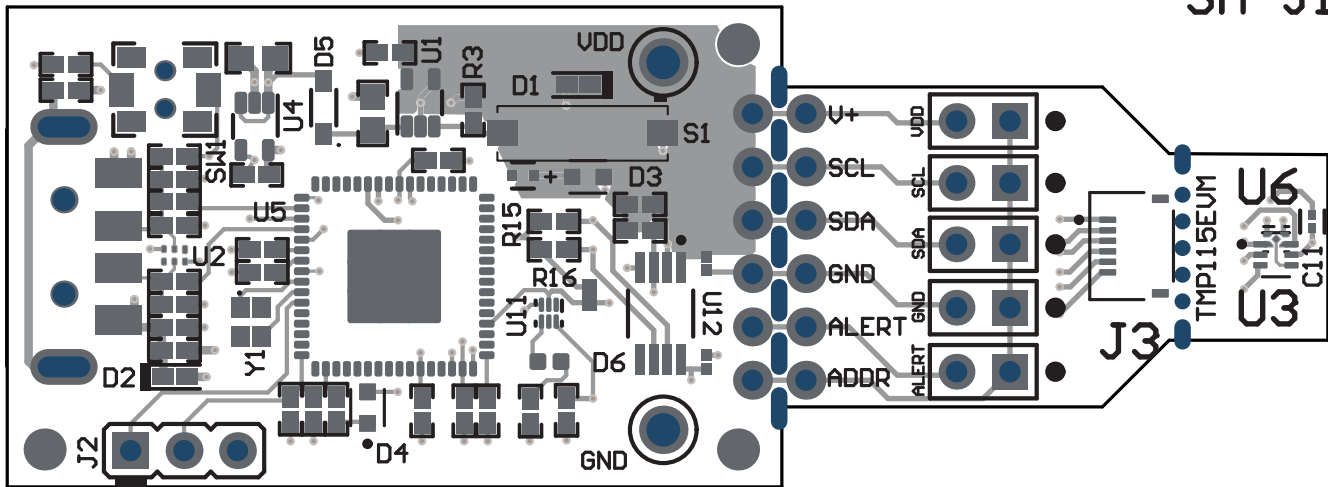

Figure 4-2. Top View

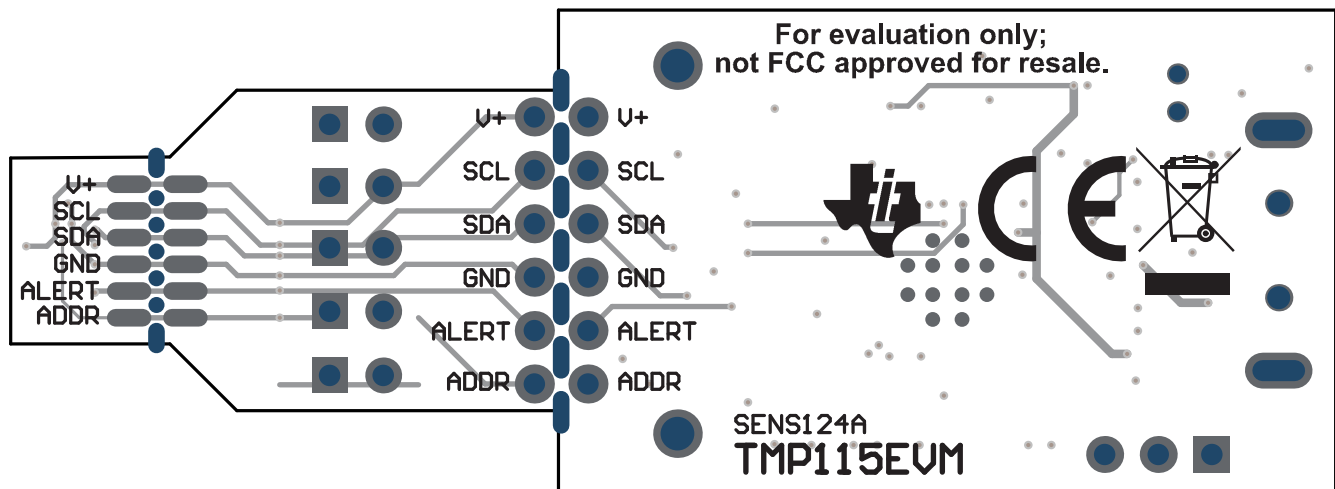

Figure 4-3. Bottom View

### 4.3 Bill of Materials

**Table 4-1. Bill of Materials**

FITTED	DESCRIPTION	DESIGNATOR	PARTNUMBER	QUANTITY	MANUFACTURER	PACKAGEREFERENCE	VALUE
Fitted	Printed Circuit Board	!PCB1	SENS124	1	Any		
Fitted	CAP, CERM, 2.2uF, 16V, +/- 10%, X5R, 0402	C1, C6	GRM155R61C225KE11D	2	MuRata	0402	2.2uF
Fitted	CAP, CERM, 10uF, 10V, +/- 20%, X5R, 0603	C2, C7	C1608X5R1A106M080AC	2	TDK	0603	10uF
Fitted	CAP, CERM, 10pF, 16V,+/- 10%, C0G, 0402	C3, C4	C0402C100K4GACTU	2	Kemet	0402	10pF
Fitted	CAP, CERM, 0.1uF, 10V,+/- 10%, X5R, 0402	C5, C13, C15, C16, C17	LMK105BJ104KV-F	5	Taiyo Yuden	0402	0.1uF
Fitted	CAP, CERM, 0.47uF, 6.3V, +/- 10%, X7R, 0402	C8, C9, C10	JMK105B7474KVHF	3	Taiyo Yuden	0402	0.47uF
Fitted	Chip Multilayer Ceramic Capacitors for General Purpose, 0201, 10000pF, X7R, 15%, 10%, 10V	C11		1			
Fitted	CAP, CERM, 2200pF, 50V, +/- 5%, X7R, 0402	C14	CL05B222JB5NNNC	1	Samsung Electro-Mechanics	0402	2200pF
Fitted	CAP, CERM, 0.1uF, 10V, +/- 10%, X5R, 0201	C18, C19	CL03A104KP3NNNC	2	Samsung Electro-Mechanics	0201	0.1uF
Fitted	Diode, Zener, 6.2V, 300 mW, SOD-523	D1, D2	BZT52C6V2T-7	2	Diodes Inc.	SOD-523	6.2V
Fitted	Green LED Indication - Discrete 2.2V 0603 (1608 Metric)	D3	SML-LX0603GW-TR	1	Lumex	0603	

**Table 4-1. Bill of Materials (continued)**

FITTED	DESCRIPTION	DESIGNATOR	PARTNUMBER	QUANTITY	MANUFACTURER	PACKAGEREFERENCE	VALUE
Fitted	Red - LED Indication - Discrete 2V 0603 (1608 Metric) 2V @ 20mA 71.5mcd 48mW	D4	SML-LX0603SIW-TR	1	Lumex	0603	
Fitted	Silicon Schottky Diode, -55 to 85 degC, SOD323, Reel, Green	D5	BAT60A	1	Infineon	SOT323	
Fitted	LED, Yellow, SMD	D6	150040YS73240	1	Würth Elektronik	1x0.5mm	Yellow
Fitted	Connector, Plug, USB Type A, R/A, Top Mount SMT	J1	48037-1000	1	Molex	USB Type A right angle	
Fitted	Conn FPC Connector SKT 6 POS 0.51mm Solder RA SMD T/R	J3	2328702-6	1	TE Connectivity	CONN_FPC_6	
Fitted	Header, 100mil, 2x1, Gold, TH	J4, J5, J6, J7, J8	5-146261-1	5	TE Connectivity	Header, 2x1, 100mil	
Fitted	Ferrite Bead, 220ohm @ 100MHz, 0.45A, 0402	L1	BLM15AG221SN1D	1	MuRata	0402	220ohm
Fitted	RES, 22, 5%, 0.1W, AEC-Q200 Grade 0, 0402	R1, R2	ERJ-2GEJ220X	2	Panasonic	0402	22
Fitted	RES, 100k, 5%, 0.1W, AEC-Q200 Grade 0, 0402	R3	ERJ-2GEJ104X	1	Panasonic	0402	100k
Fitted		R4		1			
Fitted	RES, 1.00M, 1%, 0.063W, AEC-Q200 Grade 0, 0402	R5	RMCF0402FT1M00	1	Stackpole Electronics Inc	0402	1.00Meg
Fitted	RES, 1.50k, 1%, 0.063W, AEC-Q200 Grade 0, 0402	R6	RMCF0402FT1K50	1	Stackpole Electronics Inc	0402	1.50k

**Table 4-1. Bill of Materials (continued)**

FITTED	DESCRIPTION	DESIGNATOR	PARTNUMBER	QUANTITY	MANUFACTURER	PACKAGE REFERENCE	VALUE
Fitted	RES, 47, 5%, 0.1W, AEC-Q200 Grade 0, 0402	R7	ERJ-2GEJ470X	1	Panasonic	0402	47
Fitted	RES, 110, 1%, 0.1W, AEC-Q200 Grade 0, 0402	R8	ERJ-2RKF1100X	1	Panasonic	0402	110
Fitted	RES, 4.7k, 5%, 0.063W, AEC-Q200 Grade 0, 0402	R9, R10, R15, R16	CRCW04024K70JNE D	4	Vishay-Dale	0402	4.7k
Fitted		R11		1	KOA Speer		10k
Fitted	RES, 1.0k, 5%, 0.1W, AEC-Q200 Grade 0, 0402	R12, R13	ERJ-2GEJ102X	2	Panasonic	0402	1.0k
Fitted	RES, 33.0k, 1%, 0.063W, 0402	R14	RC0402FR-0733KL	1	Yageo America	0402	33.0k
Fitted	Switch, Slide, SPST, Top Slide, SMT	S1	CHS-01TB	1	Copal Electronics	Switch, Single Top Slide, 2.5x8x2.5mm	
Fitted	Single Operation 2.54mm Pitch Open Top Jumper Socket	SH-J1	M7582-05	1	Harwin	Single Operation 2.54mm Pitch Open Top Jumper Socket	
Fitted	Switch, SPST-NO, Off-Mom, 0.05A, 12VDC, SMD	SW1	PTS820J20M SMTR LFS	1	C&K Components	3.9x2.9mm	
Fitted	Test Point, Black, Through Hole, RoHS, Bulk	TP1		1	Keystone	5011	
Fitted	Test Point, Red, Through Hole, RoHS, Bulk	TP2		1	Keystone	5010	

Table 4-1. Bill of Materials (continued)

FITTED	DESCRIPTION	DESIGNATOR	PARTNUMBER	QUANTITY	MANUFACTURER	PACKAGEREFERENCE	VALUE
Fitted	Single Output LDO, 200mA, Fixed 3.3V Output, 2 to 5.5V Input, with Low IQ, 5-pin SC70 (DCK), -40 to 125 degC, Green (RoHS & no Sb/Br)	U1, U4	TLV70033DCKR	2	Texas Instruments	DCK0005A	
Fitted	4-Channel ESD Protection Array for High-Speed Data Interfaces, DRY0006A (USON-6)	U2	TPD4E004DRYR	1	Texas Instruments	DRY0006A	
Fitted	Ultra-Small, 1.1V to 5.5V Supply, $\pm 0.2^{\circ}\text{C}$ Accurate, I2C Digital Temperature Sensor	U3	TMP115A	1	Texas Instruments	SOT6	
Fitted	16-Bit Ultra-Low-Power Microcontroller, 128KB Flash, 8KB RAM, USB, 12Bit ADC, 2 USCIs, 32Bit HW MPY, RGC0064B (VQFN-64)	U5	MSP430F5528IRGCR	1	Texas Instruments	RGC0064B	
Fitted	Low-Power Single Inverter Gate, DSF0006A, LARGE T&R	U11	SN74AUP1G04DSFR	1	Texas Instruments	DSF0006A	
Fitted	IC TRNSLTR BIDIRECTIONAL 8VSSOP	U12		1	Texas Instruments		
Fitted	Crystal, 24MHz, SMD	Y1	XRCGB24M000F2P00R0	1	MuRata	2x1.6mm	
Not Fitted	Header, 2.54mm, 3x1, Gold, TH	J2	GBC03SAAN	0	Sullins Connector Solutions	Header, 2.54mm, 3x1, TH	

**Table 4-1. Bill of Materials (continued)**

FITTED	DESCRIPTION	DESIGNATOR	PARTNUMBER	QUANTITY	MANUFACTURER	PACKAGE REFERENCE	VALUE
Not Fitted	Ultra-Small, 1.1V to 5.5V Supply, $\pm 0.2^{\circ}\text{C}$ Accurate, I2C Digital Temperature Sensor	U6	TMP115A0	0	Texas Instruments	X2SON5	

## 5 Additional Information

### 5.1 Trademarks

Windows® is a registered trademark of Microsoft Corporation.

Mac® is a registered trademark of Apple Inc.

Linux® is a registered trademark of Linus Torvalds.

All trademarks are the property of their respective owners.

## 6 Revision History

NOTE: Page numbers for previous revisions may differ from page numbers in the current version.

<b>Changes from Revision A (October 2025) to Revision B (January 2026)</b>	<b>Page</b>
• Updated descriptions for address selection throughout the document.....	1
• Updated hardware images throughout the document to reflect changes to the EVM.....	1
• Updated the <i>TMP115EVM Board Sections</i> figure in the <i>Overview</i> section.....	3
• Updated the <i>Bill of Materials</i> .....	13

<b>Changes from October 13, 2025 to October 22, 2025 (from Revision * (October 2025) to Revision A (October 2025))</b>	<b>Page</b>
• Corrected the GPN of the EVM device in the title.....	1
• Changed the temperature values for the TMP115 breakout section in <a href="#">Table 1-1</a> .....	2

## STANDARD TERMS FOR EVALUATION MODULES

1. *Delivery:* TI delivers TI evaluation boards, kits, or modules, including any accompanying demonstration software, components, and/or documentation which may be provided together or separately (collectively, an "EVM" or "EVMs") to the User ("User") in accordance with the terms set forth herein. User's acceptance of the EVM is expressly subject to the following terms.
  - 1.1 EVMs are intended solely for product or software developers for use in a research and development setting to facilitate feasibility evaluation, experimentation, or scientific analysis of TI semiconductors products. EVMs have no direct function and are not finished products. EVMs shall not be directly or indirectly assembled as a part or subassembly in any finished product. For clarification, any software or software tools provided with the EVM ("Software") shall not be subject to the terms and conditions set forth herein but rather shall be subject to the applicable terms that accompany such Software
  - 1.2 EVMs are not intended for consumer or household use. EVMs may not be sold, sublicensed, leased, rented, loaned, assigned, or otherwise distributed for commercial purposes by Users, in whole or in part, or used in any finished product or production system.
2. *Limited Warranty and Related Remedies/Disclaimers:*
  - 2.1 These terms do not apply to Software. The warranty, if any, for Software is covered in the applicable Software License Agreement.
  - 2.2 TI warrants that the TI EVM will conform to TI's published specifications for ninety (90) days after the date TI delivers such EVM to User. Notwithstanding the foregoing, TI shall not be liable for a nonconforming EVM if (a) the nonconformity was caused by neglect, misuse or mistreatment by an entity other than TI, including improper installation or testing, or for any EVMs that have been altered or modified in any way by an entity other than TI, (b) the nonconformity resulted from User's design, specifications or instructions for such EVMs or improper system design, or (c) User has not paid on time. Testing and other quality control techniques are used to the extent TI deems necessary. TI does not test all parameters of each EVM. User's claims against TI under this Section 2 are void if User fails to notify TI of any apparent defects in the EVMs within ten (10) business days after delivery, or of any hidden defects with ten (10) business days after the defect has been detected.
  - 2.3 TI's sole liability shall be at its option to repair or replace EVMs that fail to conform to the warranty set forth above, or credit User's account for such EVM. TI's liability under this warranty shall be limited to EVMs that are returned during the warranty period to the address designated by TI and that are determined by TI not to conform to such warranty. If TI elects to repair or replace such EVM, TI shall have a reasonable time to repair such EVM or provide replacements. Repaired EVMs shall be warranted for the remainder of the original warranty period. Replaced EVMs shall be warranted for a new full ninety (90) day warranty period.

### **WARNING**

**Evaluation Kits are intended solely for use by technically qualified, professional electronics experts who are familiar with the dangers and application risks associated with handling electrical mechanical components, systems, and subsystems.**

**User shall operate the Evaluation Kit within TI's recommended guidelines and any applicable legal or environmental requirements as well as reasonable and customary safeguards. Failure to set up and/or operate the Evaluation Kit within TI's recommended guidelines may result in personal injury or death or property damage. Proper set up entails following TI's instructions for electrical ratings of interface circuits such as input, output and electrical loads.**

**NOTE:**

**EXPOSURE TO ELECTROSTATIC DISCHARGE (ESD) MAY CAUSE DEGRADATION OR FAILURE OF THE EVALUATION KIT; TI RECOMMENDS STORAGE OF THE EVALUATION KIT IN A PROTECTIVE ESD BAG.**

### 3 Regulatory Notices:

#### 3.1 United States

##### 3.1.1 Notice applicable to EVMs not FCC-Approved:

**FCC NOTICE:** This kit is designed to allow product developers to evaluate electronic components, circuitry, or software associated with the kit to determine whether to incorporate such items in a finished product and software developers to write software applications for use with the end product. This kit is not a finished product and when assembled may not be resold or otherwise marketed unless all required FCC equipment authorizations are first obtained. Operation is subject to the condition that this product not cause harmful interference to licensed radio stations and that this product accept harmful interference. Unless the assembled kit is designed to operate under part 15, part 18 or part 95 of this chapter, the operator of the kit must operate under the authority of an FCC license holder or must secure an experimental authorization under part 5 of this chapter.

##### 3.1.2 For EVMs annotated as FCC – FEDERAL COMMUNICATIONS COMMISSION Part 15 Compliant:

#### **CAUTION**

This device complies with part 15 of the FCC Rules. Operation is subject to the following two conditions: (1) This device may not cause harmful interference, and (2) this device must accept any interference received, including interference that may cause undesired operation.

Changes or modifications not expressly approved by the party responsible for compliance could void the user's authority to operate the equipment.

#### **FCC Interference Statement for Class A EVM devices**

*NOTE: This equipment has been tested and found to comply with the limits for a Class A digital device, pursuant to part 15 of the FCC Rules. These limits are designed to provide reasonable protection against harmful interference when the equipment is operated in a commercial environment. This equipment generates, uses, and can radiate radio frequency energy and, if not installed and used in accordance with the instruction manual, may cause harmful interference to radio communications. Operation of this equipment in a residential area is likely to cause harmful interference in which case the user will be required to correct the interference at his own expense.*

#### **FCC Interference Statement for Class B EVM devices**

*NOTE: This equipment has been tested and found to comply with the limits for a Class B digital device, pursuant to part 15 of the FCC Rules. These limits are designed to provide reasonable protection against harmful interference in a residential installation. This equipment generates, uses and can radiate radio frequency energy and, if not installed and used in accordance with the instructions, may cause harmful interference to radio communications. However, there is no guarantee that interference will not occur in a particular installation. If this equipment does cause harmful interference to radio or television reception, which can be determined by turning the equipment off and on, the user is encouraged to try to correct the interference by one or more of the following measures:*

- Reorient or relocate the receiving antenna.
- Increase the separation between the equipment and receiver.
- Connect the equipment into an outlet on a circuit different from that to which the receiver is connected.
- Consult the dealer or an experienced radio/TV technician for help.

#### 3.2 Canada

##### 3.2.1 For EVMs issued with an Industry Canada Certificate of Conformance to RSS-210 or RSS-247

#### **Concerning EVMs Including Radio Transmitters:**

This device complies with Industry Canada license-exempt RSSs. Operation is subject to the following two conditions:

(1) this device may not cause interference, and (2) this device must accept any interference, including interference that may cause undesired operation of the device.

#### **Concernant les EVMs avec appareils radio:**

Le présent appareil est conforme aux CNR d'Industrie Canada applicables aux appareils radio exempts de licence. L'exploitation est autorisée aux deux conditions suivantes: (1) l'appareil ne doit pas produire de brouillage, et (2) l'utilisateur de l'appareil doit accepter tout brouillage radioélectrique subi, même si le brouillage est susceptible d'en compromettre le fonctionnement.

#### **Concerning EVMs Including Detachable Antennas:**

Under Industry Canada regulations, this radio transmitter may only operate using an antenna of a type and maximum (or lesser) gain approved for the transmitter by Industry Canada. To reduce potential radio interference to other users, the antenna type and its gain should be so chosen that the equivalent isotropically radiated power (e.i.r.p.) is not more than that necessary for successful communication. This radio transmitter has been approved by Industry Canada to operate with the antenna types listed in the user guide with the maximum permissible gain and required antenna impedance for each antenna type indicated. Antenna types not included in this list, having a gain greater than the maximum gain indicated for that type, are strictly prohibited for use with this device.

### Concernant les EVMs avec antennes détachables

Conformément à la réglementation d'Industrie Canada, le présent émetteur radio peut fonctionner avec une antenne d'un type et d'un gain maximal (ou inférieur) approuvé pour l'émetteur par Industrie Canada. Dans le but de réduire les risques de brouillage radioélectrique à l'intention des autres utilisateurs, il faut choisir le type d'antenne et son gain de sorte que la puissance isotrope rayonnée équivalente (p.i.r.e.) ne dépasse pas l'intensité nécessaire à l'établissement d'une communication satisfaisante. Le présent émetteur radio a été approuvé par Industrie Canada pour fonctionner avec les types d'antenne énumérés dans le manuel d'usage et ayant un gain admissible maximal et l'impédance requise pour chaque type d'antenne. Les types d'antenne non inclus dans cette liste, ou dont le gain est supérieur au gain maximal indiqué, sont strictement interdits pour l'exploitation de l'émetteur.

#### 3.3 Japan

3.3.1 *Notice for EVMs delivered in Japan:* Please see [http://www.tij.co.jp/lstds/ti\\_ja/general/eStore/notice\\_01.page](http://www.tij.co.jp/lstds/ti_ja/general/eStore/notice_01.page) 日本国内に輸入される評価用キット、ボードについては、次のところをご覧ください。

<https://www.ti.com/ja-jp/legal/notice-for-evaluation-kits-delivered-in-japan.html>

3.3.2 *Notice for Users of EVMs Considered "Radio Frequency Products" in Japan:* EVMs entering Japan may not be certified by TI as conforming to Technical Regulations of Radio Law of Japan.

If User uses EVMs in Japan, not certified to Technical Regulations of Radio Law of Japan, User is required to follow the instructions set forth by Radio Law of Japan, which includes, but is not limited to, the instructions below with respect to EVMs (which for the avoidance of doubt are stated strictly for convenience and should be verified by User):

1. Use EVMs in a shielded room or any other test facility as defined in the notification #173 issued by Ministry of Internal Affairs and Communications on March 28, 2006, based on Sub-section 1.1 of Article 6 of the Ministry's Rule for Enforcement of Radio Law of Japan,
2. Use EVMs only after User obtains the license of Test Radio Station as provided in Radio Law of Japan with respect to EVMs, or
3. Use of EVMs only after User obtains the Technical Regulations Conformity Certification as provided in Radio Law of Japan with respect to EVMs. Also, do not transfer EVMs, unless User gives the same notice above to the transferee. Please note that if User does not follow the instructions above, User will be subject to penalties of Radio Law of Japan.

【無線電波を送信する製品の開発キットをお使いになる際の注意事項】 開発キットの中には技術基準適合証明を受けていないものがあります。技術適合証明を受けていないものご使用に際しては、電波法遵守のため、以下のいずれかの措置を取っていただく必要がありますのでご注意ください。

1. 電波法施行規則第6条第1項第1号に基づく平成18年3月28日総務省告示第173号で定められた電波暗室等の試験設備でご使用いただく。
2. 実験局の免許を取得後ご使用いただく。
3. 技術基準適合証明を取得後ご使用いただく。

なお、本製品は、上記の「ご使用にあたっての注意」を譲渡先、移転先に通知しない限り、譲渡、移転できないものとします。

上記を遵守頂けない場合は、電波法の罰則が適用される可能性があることをご留意ください。日本テキサス・インスツルメンツ株式会社  
東京都新宿区西新宿 6 丁目 2 4 番 1 号  
西新宿三井ビル

3.3.3 *Notice for EVMs for Power Line Communication:* Please see [http://www.tij.co.jp/lstds/ti\\_ja/general/eStore/notice\\_02.page](http://www.tij.co.jp/lstds/ti_ja/general/eStore/notice_02.page)

電力線搬送波通信についての開発キットをお使いになる際の注意事項については、次のところをご覧ください。 <https://www.ti.com/ja-jp/legal/notice-for-evaluation-kits-for-power-line-communication.html>

#### 3.4 European Union

3.4.1 *For EVMs subject to EU Directive 2014/30/EU (Electromagnetic Compatibility Directive):*

This is a class A product intended for use in environments other than domestic environments that are connected to a low-voltage power-supply network that supplies buildings used for domestic purposes. In a domestic environment this product may cause radio interference in which case the user may be required to take adequate measures.

- 
4. *EVM Use Restrictions and Warnings:*
    - 4.1 EVMS ARE NOT FOR USE IN FUNCTIONAL SAFETY AND/OR SAFETY CRITICAL EVALUATIONS, INCLUDING BUT NOT LIMITED TO EVALUATIONS OF LIFE SUPPORT APPLICATIONS.
    - 4.2 User must read and apply the user guide and other available documentation provided by TI regarding the EVM prior to handling or using the EVM, including without limitation any warning or restriction notices. The notices contain important safety information related to, for example, temperatures and voltages.
    - 4.3 *Safety-Related Warnings and Restrictions:*
      - 4.3.1 User shall operate the EVM within TI's recommended specifications and environmental considerations stated in the user guide, other available documentation provided by TI, and any other applicable requirements and employ reasonable and customary safeguards. Exceeding the specified performance ratings and specifications (including but not limited to input and output voltage, current, power, and environmental ranges) for the EVM may cause personal injury or death, or property damage. If there are questions concerning performance ratings and specifications, User should contact a TI field representative prior to connecting interface electronics including input power and intended loads. Any loads applied outside of the specified output range may also result in unintended and/or inaccurate operation and/or possible permanent damage to the EVM and/or interface electronics. Please consult the EVM user guide prior to connecting any load to the EVM output. If there is uncertainty as to the load specification, please contact a TI field representative. During normal operation, even with the inputs and outputs kept within the specified allowable ranges, some circuit components may have elevated case temperatures. These components include but are not limited to linear regulators, switching transistors, pass transistors, current sense resistors, and heat sinks, which can be identified using the information in the associated documentation. When working with the EVM, please be aware that the EVM may become very warm.
      - 4.3.2 EVMs are intended solely for use by technically qualified, professional electronics experts who are familiar with the dangers and application risks associated with handling electrical mechanical components, systems, and subsystems. User assumes all responsibility and liability for proper and safe handling and use of the EVM by User or its employees, affiliates, contractors or designees. User assumes all responsibility and liability to ensure that any interfaces (electronic and/or mechanical) between the EVM and any human body are designed with suitable isolation and means to safely limit accessible leakage currents to minimize the risk of electrical shock hazard. User assumes all responsibility and liability for any improper or unsafe handling or use of the EVM by User or its employees, affiliates, contractors or designees.
    - 4.4 User assumes all responsibility and liability to determine whether the EVM is subject to any applicable international, federal, state, or local laws and regulations related to User's handling and use of the EVM and, if applicable, User assumes all responsibility and liability for compliance in all respects with such laws and regulations. User assumes all responsibility and liability for proper disposal and recycling of the EVM consistent with all applicable international, federal, state, and local requirements.
  5. *Accuracy of Information:* To the extent TI provides information on the availability and function of EVMs, TI attempts to be as accurate as possible. However, TI does not warrant the accuracy of EVM descriptions, EVM availability or other information on its websites as accurate, complete, reliable, current, or error-free.
  6. *Disclaimers:*
    - 6.1 EXCEPT AS SET FORTH ABOVE, EVMS AND ANY MATERIALS PROVIDED WITH THE EVM (INCLUDING, BUT NOT LIMITED TO, REFERENCE DESIGNS AND THE DESIGN OF THE EVM ITSELF) ARE PROVIDED "AS IS" AND "WITH ALL FAULTS." TI DISCLAIMS ALL OTHER WARRANTIES, EXPRESS OR IMPLIED, REGARDING SUCH ITEMS, INCLUDING BUT NOT LIMITED TO ANY EPIDEMIC FAILURE WARRANTY OR IMPLIED WARRANTIES OF MERCHANTABILITY OR FITNESS FOR A PARTICULAR PURPOSE OR NON-INFRINGEMENT OF ANY THIRD PARTY PATENTS, COPYRIGHTS, TRADE SECRETS OR OTHER INTELLECTUAL PROPERTY RIGHTS.
    - 6.2 EXCEPT FOR THE LIMITED RIGHT TO USE THE EVM SET FORTH HEREIN, NOTHING IN THESE TERMS SHALL BE CONSTRUED AS GRANTING OR CONFERRING ANY RIGHTS BY LICENSE, PATENT, OR ANY OTHER INDUSTRIAL OR INTELLECTUAL PROPERTY RIGHT OF TI, ITS SUPPLIERS/LICENSORS OR ANY OTHER THIRD PARTY, TO USE THE EVM IN ANY FINISHED END-USER OR READY-TO-USE FINAL PRODUCT, OR FOR ANY INVENTION, DISCOVERY OR IMPROVEMENT, REGARDLESS OF WHEN MADE, CONCEIVED OR ACQUIRED.
  7. *USER'S INDEMNITY OBLIGATIONS AND REPRESENTATIONS.* USER WILL DEFEND, INDEMNIFY AND HOLD TI, ITS LICENSORS AND THEIR REPRESENTATIVES HARMLESS FROM AND AGAINST ANY AND ALL CLAIMS, DAMAGES, LOSSES, EXPENSES, COSTS AND LIABILITIES (COLLECTIVELY, "CLAIMS") ARISING OUT OF OR IN CONNECTION WITH ANY HANDLING OR USE OF THE EVM THAT IS NOT IN ACCORDANCE WITH THESE TERMS. THIS OBLIGATION SHALL APPLY WHETHER CLAIMS ARISE UNDER STATUTE, REGULATION, OR THE LAW OF TORT, CONTRACT OR ANY OTHER LEGAL THEORY, AND EVEN IF THE EVM FAILS TO PERFORM AS DESCRIBED OR EXPECTED.
-

8. *Limitations on Damages and Liability:*

8.1 *General Limitations.* IN NO EVENT SHALL TI BE LIABLE FOR ANY SPECIAL, COLLATERAL, INDIRECT, PUNITIVE, INCIDENTAL, CONSEQUENTIAL, OR EXEMPLARY DAMAGES IN CONNECTION WITH OR ARISING OUT OF THESE TERMS OR THE USE OF THE EVMS , REGARDLESS OF WHETHER TI HAS BEEN ADVISED OF THE POSSIBILITY OF SUCH DAMAGES. EXCLUDED DAMAGES INCLUDE, BUT ARE NOT LIMITED TO, COST OF REMOVAL OR REINSTALLATION, ANCILLARY COSTS TO THE PROCUREMENT OF SUBSTITUTE GOODS OR SERVICES, RETESTING, OUTSIDE COMPUTER TIME, LABOR COSTS, LOSS OF GOODWILL, LOSS OF PROFITS, LOSS OF SAVINGS, LOSS OF USE, LOSS OF DATA, OR BUSINESS INTERRUPTION. NO CLAIM, SUIT OR ACTION SHALL BE BROUGHT AGAINST TI MORE THAN TWELVE (12) MONTHS AFTER THE EVENT THAT GAVE RISE TO THE CAUSE OF ACTION HAS OCCURRED.

8.2 *Specific Limitations.* IN NO EVENT SHALL TI'S AGGREGATE LIABILITY FROM ANY USE OF AN EVM PROVIDED HEREUNDER, INCLUDING FROM ANY WARRANTY, INDEMNITY OR OTHER OBLIGATION ARISING OUT OF OR IN CONNECTION WITH THESE TERMS, , EXCEED THE TOTAL AMOUNT PAID TO TI BY USER FOR THE PARTICULAR EVM(S) AT ISSUE DURING THE PRIOR TWELVE (12) MONTHS WITH RESPECT TO WHICH LOSSES OR DAMAGES ARE CLAIMED. THE EXISTENCE OF MORE THAN ONE CLAIM SHALL NOT ENLARGE OR EXTEND THIS LIMIT.

9. *Return Policy.* Except as otherwise provided, TI does not offer any refunds, returns, or exchanges. Furthermore, no return of EVM(s) will be accepted if the package has been opened and no return of the EVM(s) will be accepted if they are damaged or otherwise not in a resalable condition. If User feels it has been incorrectly charged for the EVM(s) it ordered or that delivery violates the applicable order, User should contact TI. All refunds will be made in full within thirty (30) working days from the return of the components(s), excluding any postage or packaging costs.

10. *Governing Law:* These terms and conditions shall be governed by and interpreted in accordance with the laws of the State of Texas, without reference to conflict-of-laws principles. User agrees that non-exclusive jurisdiction for any dispute arising out of or relating to these terms and conditions lies within courts located in the State of Texas and consents to venue in Dallas County, Texas. Notwithstanding the foregoing, any judgment may be enforced in any United States or foreign court, and TI may seek injunctive relief in any United States or foreign court.

Mailing Address: Texas Instruments, Post Office Box 655303, Dallas, Texas 75265  
Copyright © 2023, Texas Instruments Incorporated

## IMPORTANT NOTICE AND DISCLAIMER

TI PROVIDES TECHNICAL AND RELIABILITY DATA (INCLUDING DATASHEETS), DESIGN RESOURCES (INCLUDING REFERENCE DESIGNS), APPLICATION OR OTHER DESIGN ADVICE, WEB TOOLS, SAFETY INFORMATION, AND OTHER RESOURCES "AS IS" AND WITH ALL FAULTS, AND DISCLAIMS ALL WARRANTIES, EXPRESS AND IMPLIED, INCLUDING WITHOUT LIMITATION ANY IMPLIED WARRANTIES OF MERCHANTABILITY, FITNESS FOR A PARTICULAR PURPOSE OR NON-INFRINGEMENT OF THIRD PARTY INTELLECTUAL PROPERTY RIGHTS.

These resources are intended for skilled developers designing with TI products. You are solely responsible for (1) selecting the appropriate TI products for your application, (2) designing, validating and testing your application, and (3) ensuring your application meets applicable standards, and any other safety, security, regulatory or other requirements.

These resources are subject to change without notice. TI grants you permission to use these resources only for development of an application that uses the TI products described in the resource. Other reproduction and display of these resources is prohibited. No license is granted to any other TI intellectual property right or to any third party intellectual property right. TI disclaims responsibility for, and you fully indemnify TI and its representatives against any claims, damages, costs, losses, and liabilities arising out of your use of these resources.

TI's products are provided subject to [TI's Terms of Sale](#), [TI's General Quality Guidelines](#), or other applicable terms available either on [ti.com](#) or provided in conjunction with such TI products. TI's provision of these resources does not expand or otherwise alter TI's applicable warranties or warranty disclaimers for TI products. Unless TI explicitly designates a product as custom or customer-specified, TI products are standard, catalog, general purpose devices.

TI objects to and rejects any additional or different terms you may propose.

Copyright © 2026, Texas Instruments Incorporated

Last updated 10/2025