

EVM User's Guide: TRF1218EVM

TRF1218 Evaluation Module



Description

The TRF1218 evaluation module (EVM) is used to evaluate the TRF1218 device.

Get Started

1. Order the TRF1218EVM.
2. Download the comprehensive reference design files from the [TRF1218EVM tool folder](#).

Features

- Operates on a single 5V supply
- Designed for single-ended, 50Ω input matching
- TRF1218 50Ω differential output is matched to 100Ω differential via a Pi resistor network on board.
- Simple interface to the input and outputs through onboard 2.92mm RF connectors
- Power-down option available onboard using a jumper

Applications

- RF sampling or GSPS ADC driver
- Aerospace and defense
- Electronic Warfare
- Radar seeker front end
- Phased array radar
- Software Defined Radios
- Test and measurement
- High-speed digitizers
- Vector signal transceiver (VST)
- Wireless Communications Test

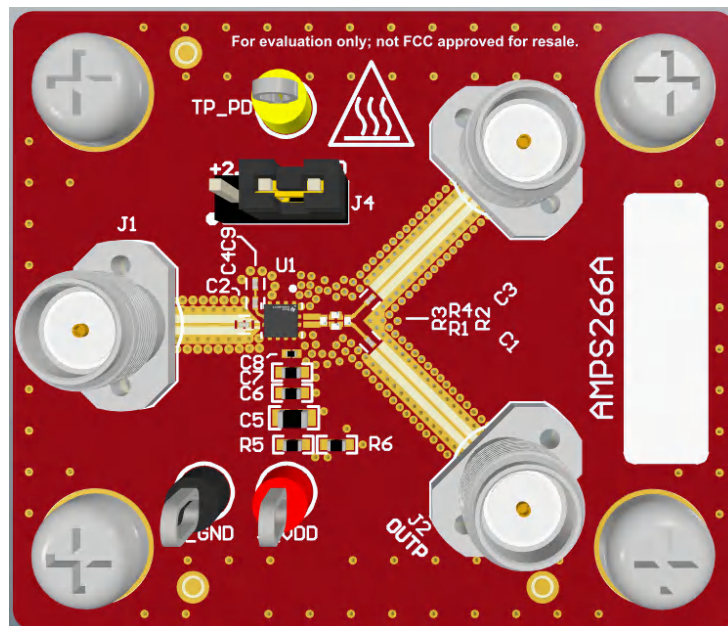

TRF1218EVM

1 Evaluation Module Overview

1.1 Introduction

This document includes the basic steps and functions that are required to provide the proper operation and quick setup of the TRF1218EVM. This document also includes a schematic diagram, a bill of materials (BOM), printed-circuit board (PCB) layouts, and test block diagrams. Throughout this document, the abbreviations *EVM*, *TRF1218 EVM* and the term *evaluation module* are synonymous with the TRF1218EVM, unless otherwise noted.

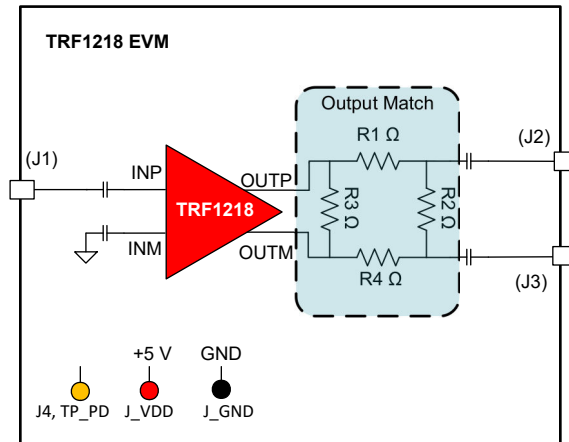
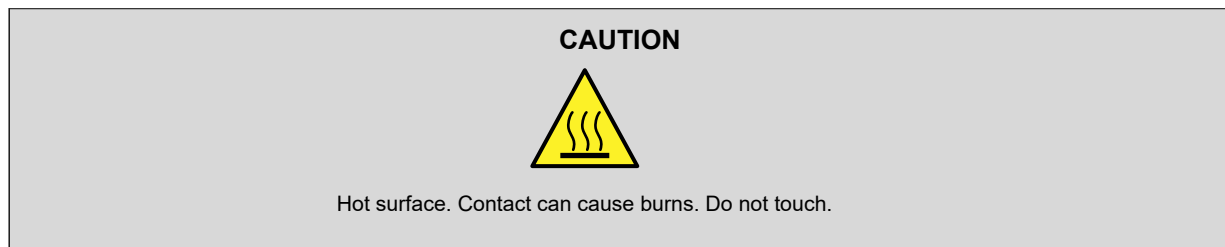

Figure 1-1. TRF1218EVM Functional Block Diagram



1.2 Kit Contents

- TRF1218EVM

1.3 Specification

The specifications for the TRF1218EVM are listed in the following table.

Connector	Parameter	Value
J1	Single-ended input RF port	10dBm Max
J2, J3	Differential output RF ports	
J_VDD	Supply voltage	5V
J4	Powerdown pin control	Short J4.1-J4.2 to disable, short J4.2-J4.3 to enable.
TP_PD	Powerdown voltage control	

1.4 Device Information

The TRF1218 is a very high performance, radio-frequency (RF) amplifier optimized for RF applications. This device is excellent for ac-coupled applications that require a single-ended to differential conversion when driving an RF sampling analog-to-digital converter (ADC), such as the high-performance [AFE7960](#). See [TRF1218 data sheet](#) for more details.

2 Hardware

2.1 Setup

2.1.1 General Use

This section provides general use information for the TRF1218EVM. See [Section 2.1.2.1](#) for a general, single-tone setup diagram as a reference point for the following instructions (some components, such as supply bypass capacitors, are omitted for clarity):

1. Recommended power-up sequence:
 - a. Before connecting the power-supply cables to the EVM, set the dc output power supply to 5V.
 - b. Set the current limit of the dc output power supply at 250mA.
 - c. Ensure that the supply is turned off, and then connect the power supply cables to the J_VDD and J_GND connectors of the EVM.
 - d. Turn on the dc power supply of $V_{CC} = 5V$. The quiescent current (I_Q) drawn from the power supply is typically 190mA.
 - e. If the supply current is low, then verify that the device is not disabled by the PD pin, on J4.
2. Power-down option:
 - a. To power down the device, connect J4.1 to J4.2 or apply 2.8V to TP_PD
3. Matching considerations:
 - a. The resistive impedance matching network at the TRF1218 output converts the 50 Ω differential output to the more common 100 Ω differential impedance; however, this network introduces 9.6dB of attenuation that must be accounted for in the signal chain. Additional passive components on the TRF1218EVM may contribute to further signal losses and SNR degradation — refer to the [Bill of Materials](#) for R1, R2, R3, and R4 values.
 - b. Note that when driving a 50 Ω differential-input ADC directly with the TRF1218, resistive attenuation is not required. The resistive matching network is included on this EVM solely to accommodate the 50 Ω single-ended characteristics of standard coaxial cables and 2.92mm RF connectors.
 - c. See [TRF1218 data sheet](#) for more details.

2.1.2 Test Setup Diagrams

This section includes general recommendations for gain, OP1dB, S-parameter, noise figure, and two-tone OIP3 setup while measuring the TRF1218 device.

2.1.2.1 Gain and OP1dB Test Setup

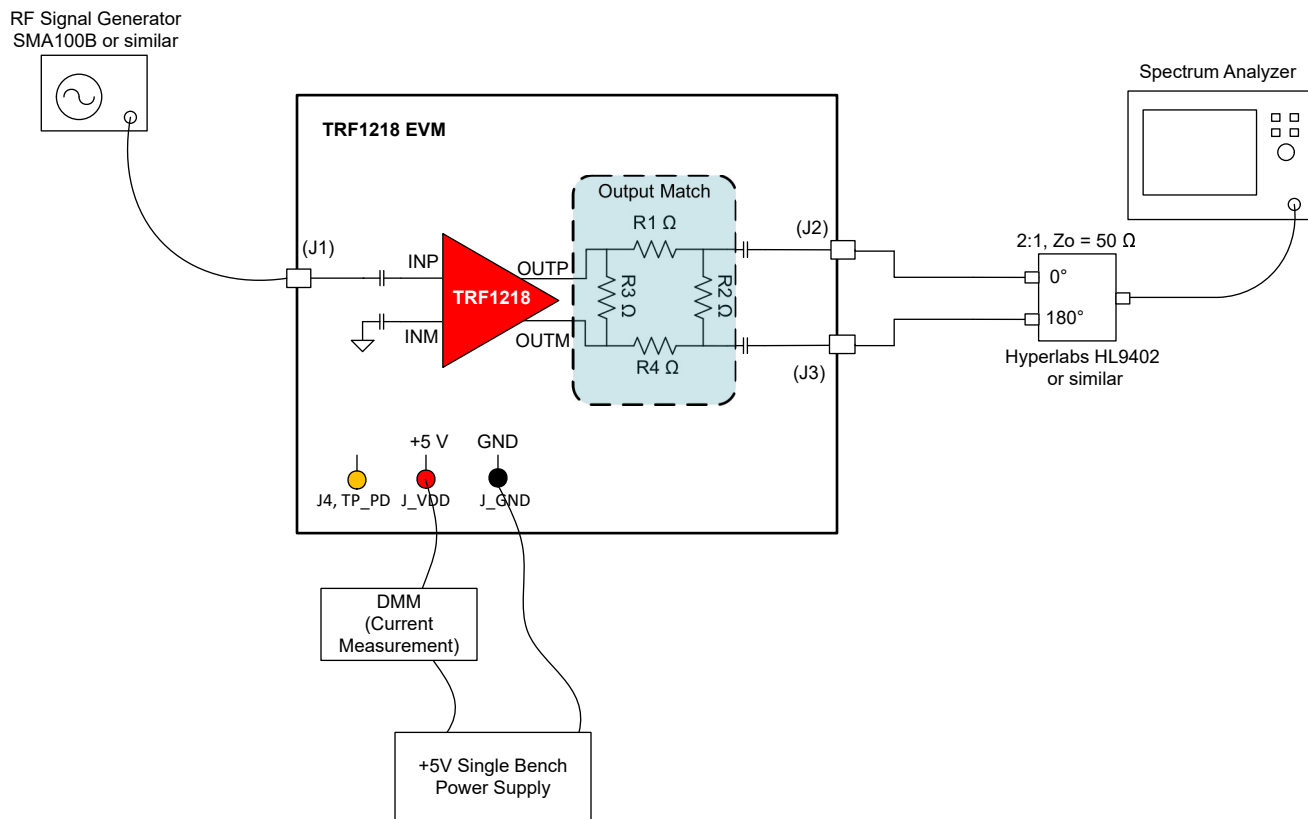

Figure 2-1. Gain and OP1dB Test Setup

Single-tone measurement setup recommendation:

1. Connect an RF signal generator to input 2.92mm RF connector, J1.
2. The RF signal generator used must support >20GHz signal frequency for testing out the TRF1218EVM.
3. The TRF1218EVM device input is 50Ω in the pass band.
4. The EVM outputs are fully differential (or 180° out of phase) at J2 and J3 2.92mm RF connectors. The TRF1218EVM has 100Ω differential matched output impedance. A pi resistive network(R1,R2,R3,R4) is used to convert 50Ω output differential impedance of TRF1218 to 100Ω differential.
5. When connecting to a spectrum analyzer, the differential signal out of the EVM must be converted to a single-ended signal using an external passive balun as shown in [Section 2.1.2.1](#).
6. Lastly, properly characterize and account for the insertion loss of RF coaxial (coax) cables, 50Ω to 100Ω matching loss (9.6dB), and passive balun to measure accurate gain and power levels for the device.

2.1.2.2 Noise Figure Test Setup

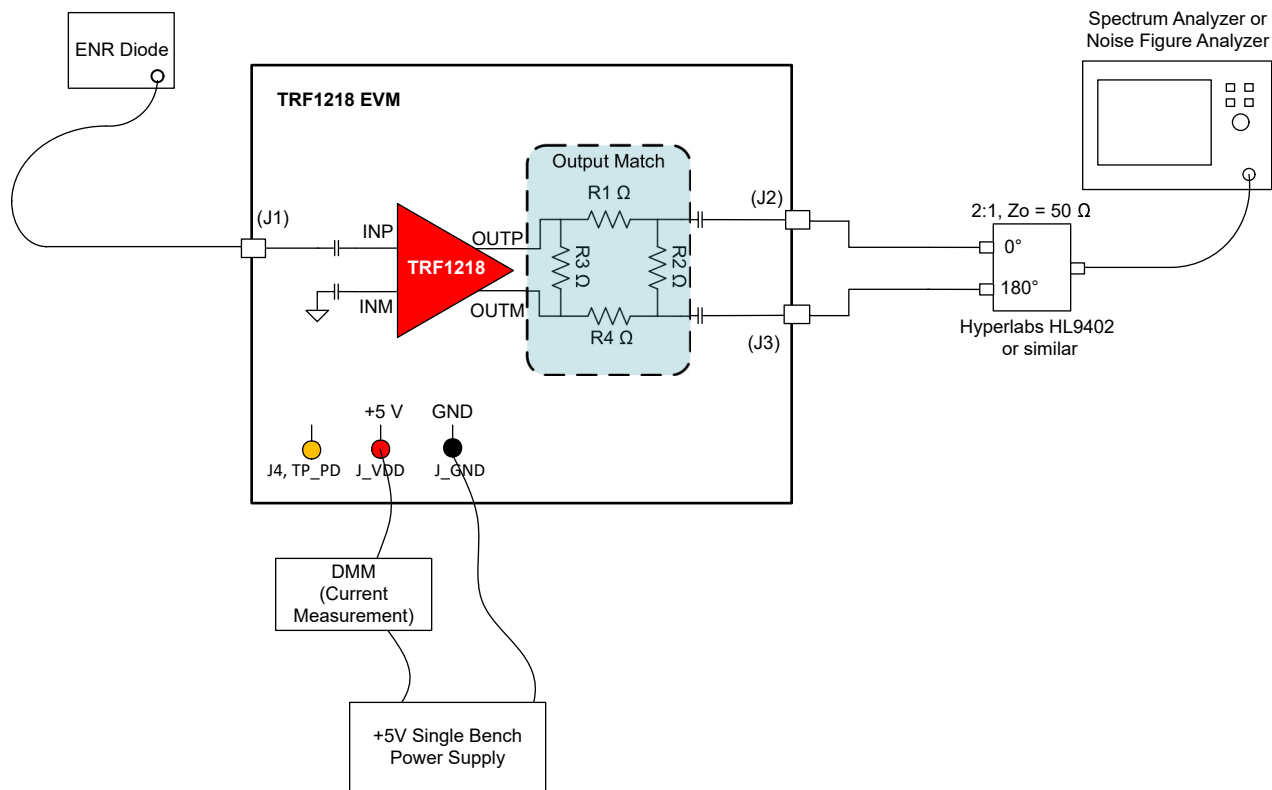

Figure 2-2. Noise Figure Test Setup

Use the following guidelines for noise figure (NF) measurement:

1. Figure 2-2 shows the traditional Y-factor method for NF measurement, using a noise diode and a spectrum analyzer (or a noise figure analyzer).
2. While measuring, take into account any RF cable losses to the EVM. Any external input attenuator added for matching results in proportional NF degradation and must be calibrated out in the measurement.
3. Onboard losses of the input traces at the device input pin must be factored into the NF measurement.
4. The loss after the device output is significant, due to on board pi network (9.6dB), factoring the output loss into the NF measurement is important. Equation 1 shows the Friis equation for a cascaded noise factor used to calculate the NF of the device from the total measured NF. The noise factor of the device, F_1 , can then be extracted and converted into a logarithmic scale to give the TRF1218 NF.

$$F_{\text{total}} = F_1 + \frac{F_2 - 1}{G_1} \quad (1)$$

where

- F_{total} = the total measured noise factor
- F_1 = the noise factor of the device
- G_1 = the gain of the device
- F_2 = the noise factor of the loss on the output

2.1.2.3 Two-Tone OIP3 Test Setup

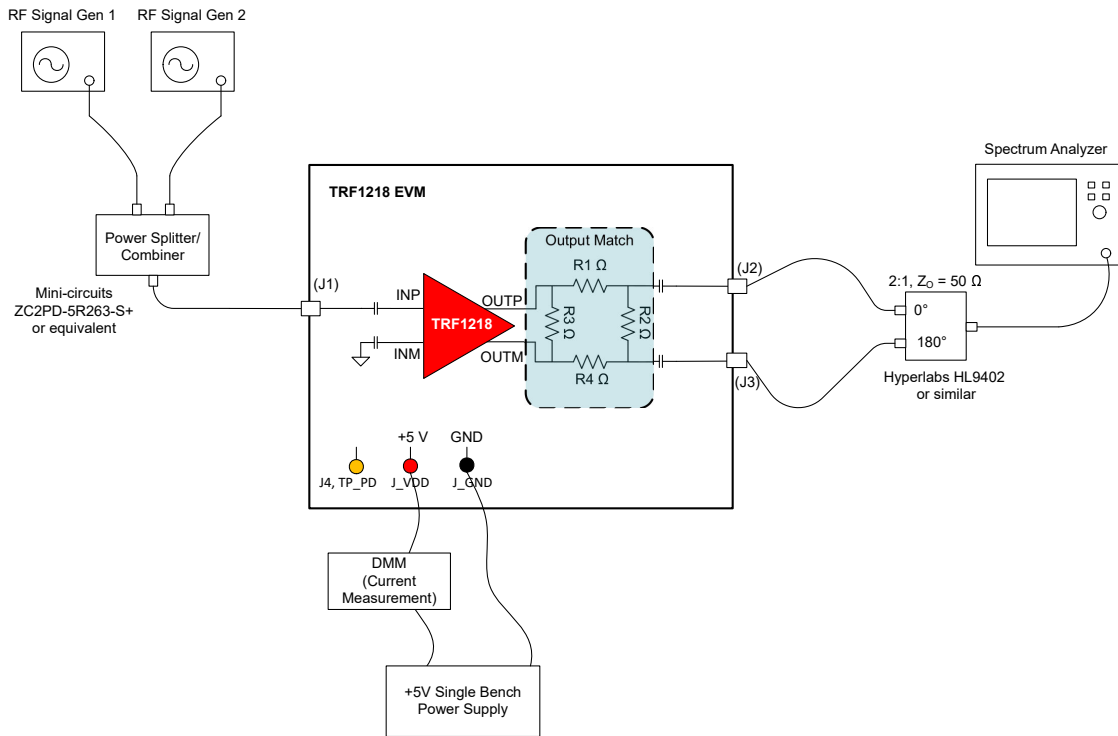

Figure 2-3. OIP3 Test Setup

Use the following guidelines for two-tone OIP3 measurement:

1. [Figure 2-3](#) shows the combination of two signal generator outputs using an in-phase power splitter and combiner. Use an optional 3dB to 6dB attenuator at the signal-generator outputs to prevent the generators from interacting, resulting in signal-generator IMD3 spurs.
2. Set both the signal generator outputs to a power level and frequency spacing so that the signal generator yields the desired output power, P_{OUT} , at the device.
3. Keep the output power level within the TRF1218 linear operating range. As a general rule, keep the total output power level approximately 6dB to 8dB less than the 1dB compression point. See the device data sheet for the supported output power levels.
4. For the OIP3 test, the two tones can be spaced by the specified frequency.
5. Set the spectrum analyzer attenuation setting appropriately so that the spectrum analyzer nonlinearity does not affect the measurements.
6. Keep spectrum analyzer RBW and VBW settings identical for main tone and IM3 products.

For output IP3 calculation, take into account the combined losses at the desired frequency band between the TRF1218EVM output to the spectrum analyzer input. The combined power loss (P_{LOSS}) is due to the resistive match at DUT output, PCB output trace, RF coax cable, 180° passive balun, and any attenuator pads used for external matching. [Equation 2](#) gives the calculated OIP3.

$$\text{Output IP3} = (P_{IN_SA} - \text{IMD3})/2 + P_{IN_SA} + P_{LOSS} \quad (2)$$

where

- P_{IN_SA} = Input power per tone into the spectrum analyzer
- P_{LOSS} = Power loss from the device output to the spectrum analyzer input
- IMD3 = Higher power of the two intermodulation distortion products recorded at either $2f_1 - f_2$ or $2f_2 - f_1$
- $P_{IN_SA} + P_{LOSS} = P_{OUT}$ is the amplifier output power per tone

3.2 PCB Layout

Figure 3-2 through Figure 3-5 illustrate the PCB layers for this EVM.

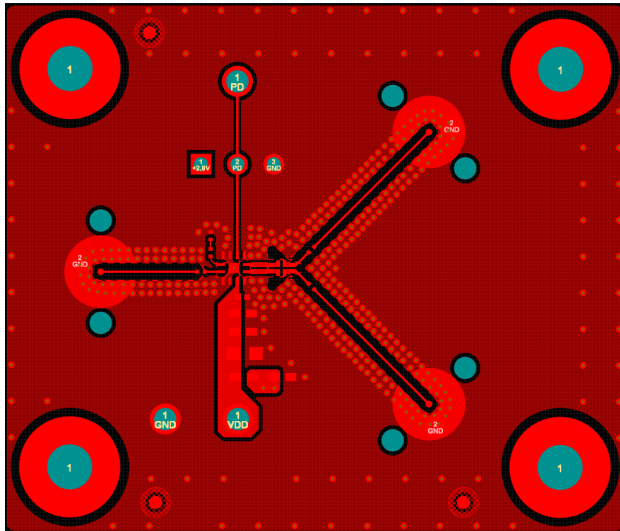

Figure 3-2. Top Layer

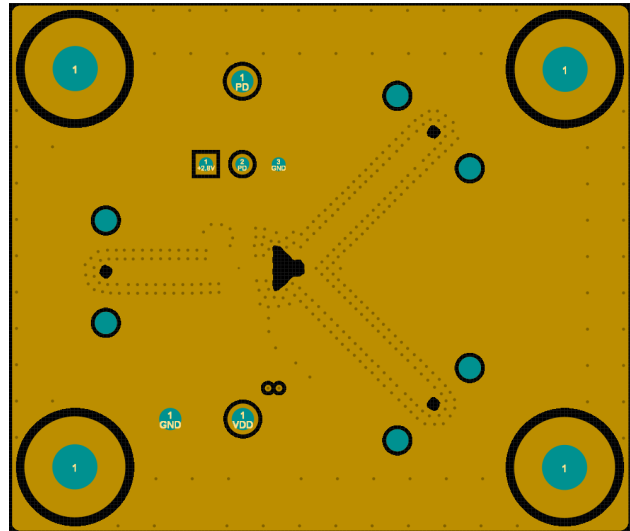

Figure 3-3. Layer 2

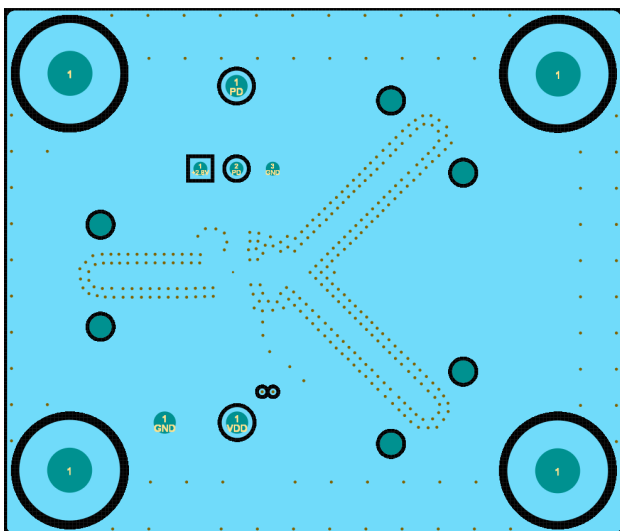

Figure 3-4. Layer 3

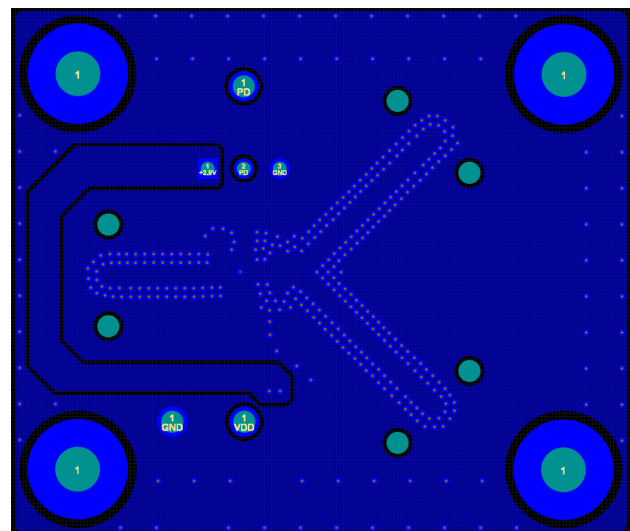

Figure 3-5. Bottom Layer

3.2.1 Stack-Up and Material

The TRF1218EVM is a four-layer board whose material type is Rogers® 4350B. The top layer routes the power, ground, and signals between 2.92mm RF connectors and the device. Second layer is the reference RF ground layer. The signal trace impedance is targeted at 50Ω. The bottom three layers are ground layers. [Table 3-1](#) lists the EVM stack-up.

Table 3-1. TRF1218EVM Stack-Up

Layer	Name	Material	Thickness (mils)	Dielectric Constant
	Top Overlay			
	Top Solder	Solder Resist	1.00	3.5
1	Top Layer	Copper	1.40	
	Dielectric 1	Rogers 4350B	4.00	3.48
2	GND	Copper	1.40	
	Dielectric 2	IT180A	46	4.2
3	GND	Copper	1.40	
	Dielectric 3	IT180A	4	4.2
4	Bottom Layer	Copper	1.40	
	Bottom Solder	Solder Resist	1.00	3.5
	Bottom Overlay			

3.3 Bill of Materials (BOM)

Table 3-2 lists the BOM.

Table 3-2. Bill of Materials (BOM)

Designator	Quantity	Value	Description	Package Reference	Part Number	Manufacturer
!PCB	1		Printed Circuit Board		AMPS266A	Any
C1, C2, C3, C4, C9	5	100nF	0.1 μ F \pm 20% 16V Ceramic Capacitor 0201 (0603 Metric)	0201	560Z104MTT	KYOCERA AVX
C5	1	22 μ F	CAP, CERM, 22 μ F, 10 V, +/- 20%, X5R, 0603	0603	CL10A226MP8NUNE	Samsung Electro-Mechanics
C6, C7	2	2.2 μ F	CAP, CERM, 2.2 μ F, 10 V, +/- 10%, X7S, 0402	0402	C1005X7S1A225K050BC	TDK
C8	1	0.22 μ F	CAP, CERM, 0.22 μ F, 10 V, +/- 20%, X5R, 0201	0201	LMK063BJ224MP-F	Taiyo Yuden
H1, H2, H3, H4	4		Machine Screw, Round, #4-40 x 1/4, Nylon, Philips panhead	Screw	NY PMS 440 0025 PH	B&F Fastener Supply
H5, H6, H7, H8	4		Standoff, Hex, 0.5"L #4-40 Nylon	Standoff	1902C	Keystone
J1, J2, J3	3		2.92mm Connector Jack, Female Socket 50Ohm Surface Mount Compression	SMAF_COMP	SF1521-60070-1S	SV Microwave
J4	1		Header, 100mil, 3x1, Tin, TH	Header, 3 PIN, 100mil, Tin	PEC03SAAN	Sullins Connector Solutions
J_GND	1		Test Point, Multipurpose, Black, TH	Black Multipurpose Testpoint	5011	Keystone Electronics
J_VDD	1		Test Point, Multipurpose, Red, TH	Red Multipurpose Testpoint	5010	Keystone Electronics
LBL1	1		Thermal Transfer Printable Labels, 0.650" W x 0.200" H - 10,000 per roll	PCB Label 0.650 x 0.200 inch	THT-14-423-10	Brady

Table 3-2. Bill of Materials (BOM) (continued)

Designator	Quantity	Value	Description	Package Reference	Part Number	Manufacturer
R1	1	50	50 Ohms $\pm 2\%$ 0.03W, 1/32W Chip Resistor 02016 (0504 Metric) RF, High Frequency Thin Film	02016	CH02016-50RGFT	Vishay Sfernice
R2	1	500	500 Ohms $\pm 2\%$ 0.03W, 1/32W Chip Resistor 02016 (0504 Metric) RF, High Frequency Thin Film	02016	CH02016-500RGFT	Vishay
R3	1	75	75 Ohms $\pm 2\%$ 0.03W, 1/32W Chip Resistor 02016 (0504 Metric) RF, High Frequency Thin Film	02016	CH02016-75RGFT	Vishay
R4	1	50	Thin Film Surface Mnt Resistor 02016 Case 50Ohm $\pm 2\%$ 0.03W ± 100 ppm/degC	02016	CH02016-50RGFT	Vishay
R5	1	2.49k	RES, 2.49 k, 1%, 0.063 W, AEC-Q200 Grade 0, 0402	0402	CRCW04022K49FKED	Vishay-Dale
R6	1	3.24k	RES, 3.24 k, 1%, 0.063 W, AEC-Q200 Grade 0, 0402	0402	CRCW04023K24FKED	Vishay-Dale
SH-J1	1	1x2	Shunt, 100mil, Gold plated, Black	Shunt	SNT-100-BK-G	Samtec
TP_PD	1		Test Point, Compact, Yellow, TH	Yellow Compact Testpoint	5009	Keystone Electronics
U1	1		RF IC	WQFN-FCRLF12	TRF1218RPVR	Texas Instruments
FID1, FID2, FID3	0		Fiducial mark. There is nothing to buy or mount.	N/A	N/A	N/A

4 Additional Information

Trademarks

Rogers® is a registered trademark of Isola USA Corporation.
All trademarks are the property of their respective owners.

5 Related Documentation

For related documentation, see the following:

- Texas Instruments, [TRF1218 data sheet](#).

STANDARD TERMS FOR EVALUATION MODULES

1. *Delivery:* TI delivers TI evaluation boards, kits, or modules, including any accompanying demonstration software, components, and/or documentation which may be provided together or separately (collectively, an "EVM" or "EVMs") to the User ("User") in accordance with the terms set forth herein. User's acceptance of the EVM is expressly subject to the following terms.
 - 1.1 EVMs are intended solely for product or software developers for use in a research and development setting to facilitate feasibility evaluation, experimentation, or scientific analysis of TI semiconductor products. EVMs have no direct function and are not finished products. EVMs shall not be directly or indirectly assembled as a part or subassembly in any finished product. For clarification, any software or software tools provided with the EVM ("Software") shall not be subject to the terms and conditions set forth herein but rather shall be subject to the applicable terms that accompany such Software
 - 1.2 EVMs are not intended for consumer or household use. EVMs may not be sold, sublicensed, leased, rented, loaned, assigned, or otherwise distributed for commercial purposes by Users, in whole or in part, or used in any finished product or production system.
2. *Limited Warranty and Related Remedies/Disclaimers:*
 - 2.1 These terms do not apply to Software. The warranty, if any, for Software is covered in the applicable Software License Agreement.
 - 2.2 TI warrants that the TI EVM will conform to TI's published specifications for ninety (90) days after the date TI delivers such EVM to User. Notwithstanding the foregoing, TI shall not be liable for a nonconforming EVM if (a) the nonconformity was caused by neglect, misuse or mistreatment by an entity other than TI, including improper installation or testing, or for any EVMs that have been altered or modified in any way by an entity other than TI, (b) the nonconformity resulted from User's design, specifications or instructions for such EVMs or improper system design, or (c) User has not paid on time. Testing and other quality control techniques are used to the extent TI deems necessary. TI does not test all parameters of each EVM. User's claims against TI under this Section 2 are void if User fails to notify TI of any apparent defects in the EVMs within ten (10) business days after delivery, or of any hidden defects with ten (10) business days after the defect has been detected.
 - 2.3 TI's sole liability shall be at its option to repair or replace EVMs that fail to conform to the warranty set forth above, or credit User's account for such EVM. TI's liability under this warranty shall be limited to EVMs that are returned during the warranty period to the address designated by TI and that are determined by TI not to conform to such warranty. If TI elects to repair or replace such EVM, TI shall have a reasonable time to repair such EVM or provide replacements. Repaired EVMs shall be warranted for the remainder of the original warranty period. Replaced EVMs shall be warranted for a new full ninety (90) day warranty period.

WARNING

Evaluation Kits are intended solely for use by technically qualified, professional electronics experts who are familiar with the dangers and application risks associated with handling electrical mechanical components, systems, and subsystems.

User shall operate the Evaluation Kit within TI's recommended guidelines and any applicable legal or environmental requirements as well as reasonable and customary safeguards. Failure to set up and/or operate the Evaluation Kit within TI's recommended guidelines may result in personal injury or death or property damage. Proper set up entails following TI's instructions for electrical ratings of interface circuits such as input, output and electrical loads.

NOTE:

EXPOSURE TO ELECTROSTATIC DISCHARGE (ESD) MAY CAUSE DEGRADATION OR FAILURE OF THE EVALUATION KIT; TI RECOMMENDS STORAGE OF THE EVALUATION KIT IN A PROTECTIVE ESD BAG.

3 Regulatory Notices:

3.1 United States

3.1.1 Notice applicable to EVMs not FCC-Approved:

FCC NOTICE: This kit is designed to allow product developers to evaluate electronic components, circuitry, or software associated with the kit to determine whether to incorporate such items in a finished product and software developers to write software applications for use with the end product. This kit is not a finished product and when assembled may not be resold or otherwise marketed unless all required FCC equipment authorizations are first obtained. Operation is subject to the condition that this product not cause harmful interference to licensed radio stations and that this product accept harmful interference. Unless the assembled kit is designed to operate under part 15, part 18 or part 95 of this chapter, the operator of the kit must operate under the authority of an FCC license holder or must secure an experimental authorization under part 5 of this chapter.

3.1.2 For EVMs annotated as FCC – FEDERAL COMMUNICATIONS COMMISSION Part 15 Compliant:

CAUTION

This device complies with part 15 of the FCC Rules. Operation is subject to the following two conditions: (1) This device may not cause harmful interference, and (2) this device must accept any interference received, including interference that may cause undesired operation.

Changes or modifications not expressly approved by the party responsible for compliance could void the user's authority to operate the equipment.

FCC Interference Statement for Class A EVM devices

NOTE: This equipment has been tested and found to comply with the limits for a Class A digital device, pursuant to part 15 of the FCC Rules. These limits are designed to provide reasonable protection against harmful interference when the equipment is operated in a commercial environment. This equipment generates, uses, and can radiate radio frequency energy and, if not installed and used in accordance with the instruction manual, may cause harmful interference to radio communications. Operation of this equipment in a residential area is likely to cause harmful interference in which case the user will be required to correct the interference at his own expense.

FCC Interference Statement for Class B EVM devices

NOTE: This equipment has been tested and found to comply with the limits for a Class B digital device, pursuant to part 15 of the FCC Rules. These limits are designed to provide reasonable protection against harmful interference in a residential installation. This equipment generates, uses and can radiate radio frequency energy and, if not installed and used in accordance with the instructions, may cause harmful interference to radio communications. However, there is no guarantee that interference will not occur in a particular installation. If this equipment does cause harmful interference to radio or television reception, which can be determined by turning the equipment off and on, the user is encouraged to try to correct the interference by one or more of the following measures:

- Reorient or relocate the receiving antenna.
- Increase the separation between the equipment and receiver.
- Connect the equipment into an outlet on a circuit different from that to which the receiver is connected.
- Consult the dealer or an experienced radio/TV technician for help.

3.2 Canada

3.2.1 For EVMs issued with an Industry Canada Certificate of Conformance to RSS-210 or RSS-247

Concerning EVMs Including Radio Transmitters:

This device complies with Industry Canada license-exempt RSSs. Operation is subject to the following two conditions:

(1) this device may not cause interference, and (2) this device must accept any interference, including interference that may cause undesired operation of the device.

Concernant les EVMs avec appareils radio:

Le présent appareil est conforme aux CNR d'Industrie Canada applicables aux appareils radio exempts de licence. L'exploitation est autorisée aux deux conditions suivantes: (1) l'appareil ne doit pas produire de brouillage, et (2) l'utilisateur de l'appareil doit accepter tout brouillage radioélectrique subi, même si le brouillage est susceptible d'en compromettre le fonctionnement.

Concerning EVMs Including Detachable Antennas:

Under Industry Canada regulations, this radio transmitter may only operate using an antenna of a type and maximum (or lesser) gain approved for the transmitter by Industry Canada. To reduce potential radio interference to other users, the antenna type and its gain should be so chosen that the equivalent isotropically radiated power (e.i.r.p.) is not more than that necessary for successful communication. This radio transmitter has been approved by Industry Canada to operate with the antenna types listed in the user guide with the maximum permissible gain and required antenna impedance for each antenna type indicated. Antenna types not included in this list, having a gain greater than the maximum gain indicated for that type, are strictly prohibited for use with this device.

Concernant les EVMs avec antennes détachables

Conformément à la réglementation d'Industrie Canada, le présent émetteur radio peut fonctionner avec une antenne d'un type et d'un gain maximal (ou inférieur) approuvé pour l'émetteur par Industrie Canada. Dans le but de réduire les risques de brouillage radioélectrique à l'intention des autres utilisateurs, il faut choisir le type d'antenne et son gain de sorte que la puissance isotrope rayonnée équivalente (p.i.r.e.) ne dépasse pas l'intensité nécessaire à l'établissement d'une communication satisfaisante. Le présent émetteur radio a été approuvé par Industrie Canada pour fonctionner avec les types d'antenne énumérés dans le manuel d'usage et ayant un gain admissible maximal et l'impédance requise pour chaque type d'antenne. Les types d'antenne non inclus dans cette liste, ou dont le gain est supérieur au gain maximal indiqué, sont strictement interdits pour l'exploitation de l'émetteur.

3.3 Japan

3.3.1 *Notice for EVMs delivered in Japan:* Please see http://www.tij.co.jp/lstds/ti_ja/general/eStore/notice_01.page 日本国内に輸入される評価用キット、ボードについては、次のところをご覧ください。

<https://www.ti.com/ja-jp/legal/notice-for-evaluation-kits-delivered-in-japan.html>

3.3.2 *Notice for Users of EVMs Considered "Radio Frequency Products" in Japan:* EVMs entering Japan may not be certified by TI as conforming to Technical Regulations of Radio Law of Japan.

If User uses EVMs in Japan, not certified to Technical Regulations of Radio Law of Japan, User is required to follow the instructions set forth by Radio Law of Japan, which includes, but is not limited to, the instructions below with respect to EVMs (which for the avoidance of doubt are stated strictly for convenience and should be verified by User):

1. Use EVMs in a shielded room or any other test facility as defined in the notification #173 issued by Ministry of Internal Affairs and Communications on March 28, 2006, based on Sub-section 1.1 of Article 6 of the Ministry's Rule for Enforcement of Radio Law of Japan,
2. Use EVMs only after User obtains the license of Test Radio Station as provided in Radio Law of Japan with respect to EVMs, or
3. Use of EVMs only after User obtains the Technical Regulations Conformity Certification as provided in Radio Law of Japan with respect to EVMs. Also, do not transfer EVMs, unless User gives the same notice above to the transferee. Please note that if User does not follow the instructions above, User will be subject to penalties of Radio Law of Japan.

【無線電波を送信する製品の開発キットをお使いになる際の注意事項】 開発キットの中には技術基準適合証明を受けていないものがあります。技術適合証明を受けていないものご使用に際しては、電波法遵守のため、以下のいずれかの措置を取っていただく必要がありますのでご注意ください。

1. 電波法施行規則第6条第1項第1号に基づく平成18年3月28日総務省告示第173号で定められた電波暗室等の試験設備でご使用いただく。
2. 実験局の免許を取得後ご使用いただく。
3. 技術基準適合証明を取得後ご使用いただく。

なお、本製品は、上記の「ご使用にあたっての注意」を譲渡先、移転先に通知しない限り、譲渡、移転できないものとします。

上記を遵守頂けない場合は、電波法の罰則が適用される可能性があることをご留意ください。日本テキサス・イ

ンスツルメンツ株式会社

東京都新宿区西新宿 6 丁目 2 4 番 1 号

西新宿三井ビル

3.3.3 *Notice for EVMs for Power Line Communication:* Please see http://www.tij.co.jp/lstds/ti_ja/general/eStore/notice_02.page

電力線搬送波通信についての開発キットをお使いになる際の注意事項については、次のところをご覧ください。 <https://www.ti.com/ja-jp/legal/notice-for-evaluation-kits-for-power-line-communication.html>

3.4 European Union

3.4.1 *For EVMs subject to EU Directive 2014/30/EU (Electromagnetic Compatibility Directive):*

This is a class A product intended for use in environments other than domestic environments that are connected to a low-voltage power-supply network that supplies buildings used for domestic purposes. In a domestic environment this product may cause radio interference in which case the user may be required to take adequate measures.

-
- 4 *EVM Use Restrictions and Warnings:*
 - 4.1 EVMS ARE NOT FOR USE IN FUNCTIONAL SAFETY AND/OR SAFETY CRITICAL EVALUATIONS, INCLUDING BUT NOT LIMITED TO EVALUATIONS OF LIFE SUPPORT APPLICATIONS.
 - 4.2 User must read and apply the user guide and other available documentation provided by TI regarding the EVM prior to handling or using the EVM, including without limitation any warning or restriction notices. The notices contain important safety information related to, for example, temperatures and voltages.
 - 4.3 *Safety-Related Warnings and Restrictions:*
 - 4.3.1 User shall operate the EVM within TI's recommended specifications and environmental considerations stated in the user guide, other available documentation provided by TI, and any other applicable requirements and employ reasonable and customary safeguards. Exceeding the specified performance ratings and specifications (including but not limited to input and output voltage, current, power, and environmental ranges) for the EVM may cause personal injury or death, or property damage. If there are questions concerning performance ratings and specifications, User should contact a TI field representative prior to connecting interface electronics including input power and intended loads. Any loads applied outside of the specified output range may also result in unintended and/or inaccurate operation and/or possible permanent damage to the EVM and/or interface electronics. Please consult the EVM user guide prior to connecting any load to the EVM output. If there is uncertainty as to the load specification, please contact a TI field representative. During normal operation, even with the inputs and outputs kept within the specified allowable ranges, some circuit components may have elevated case temperatures. These components include but are not limited to linear regulators, switching transistors, pass transistors, current sense resistors, and heat sinks, which can be identified using the information in the associated documentation. When working with the EVM, please be aware that the EVM may become very warm.
 - 4.3.2 EVMs are intended solely for use by technically qualified, professional electronics experts who are familiar with the dangers and application risks associated with handling electrical mechanical components, systems, and subsystems. User assumes all responsibility and liability for proper and safe handling and use of the EVM by User or its employees, affiliates, contractors or designees. User assumes all responsibility and liability to ensure that any interfaces (electronic and/or mechanical) between the EVM and any human body are designed with suitable isolation and means to safely limit accessible leakage currents to minimize the risk of electrical shock hazard. User assumes all responsibility and liability for any improper or unsafe handling or use of the EVM by User or its employees, affiliates, contractors or designees.
 - 4.4 User assumes all responsibility and liability to determine whether the EVM is subject to any applicable international, federal, state, or local laws and regulations related to User's handling and use of the EVM and, if applicable, User assumes all responsibility and liability for compliance in all respects with such laws and regulations. User assumes all responsibility and liability for proper disposal and recycling of the EVM consistent with all applicable international, federal, state, and local requirements.
 5. *Accuracy of Information:* To the extent TI provides information on the availability and function of EVMs, TI attempts to be as accurate as possible. However, TI does not warrant the accuracy of EVM descriptions, EVM availability or other information on its websites as accurate, complete, reliable, current, or error-free.
 6. *Disclaimers:*
 - 6.1 EXCEPT AS SET FORTH ABOVE, EVMS AND ANY MATERIALS PROVIDED WITH THE EVM (INCLUDING, BUT NOT LIMITED TO, REFERENCE DESIGNS AND THE DESIGN OF THE EVM ITSELF) ARE PROVIDED "AS IS" AND "WITH ALL FAULTS." TI DISCLAIMS ALL OTHER WARRANTIES, EXPRESS OR IMPLIED, REGARDING SUCH ITEMS, INCLUDING BUT NOT LIMITED TO ANY EPIDEMIC FAILURE WARRANTY OR IMPLIED WARRANTIES OF MERCHANTABILITY OR FITNESS FOR A PARTICULAR PURPOSE OR NON-INFRINGEMENT OF ANY THIRD PARTY PATENTS, COPYRIGHTS, TRADE SECRETS OR OTHER INTELLECTUAL PROPERTY RIGHTS.
 - 6.2 EXCEPT FOR THE LIMITED RIGHT TO USE THE EVM SET FORTH HEREIN, NOTHING IN THESE TERMS SHALL BE CONSTRUED AS GRANTING OR CONFERRING ANY RIGHTS BY LICENSE, PATENT, OR ANY OTHER INDUSTRIAL OR INTELLECTUAL PROPERTY RIGHT OF TI, ITS SUPPLIERS/LICENSORS OR ANY OTHER THIRD PARTY, TO USE THE EVM IN ANY FINISHED END-USER OR READY-TO-USE FINAL PRODUCT, OR FOR ANY INVENTION, DISCOVERY OR IMPROVEMENT, REGARDLESS OF WHEN MADE, CONCEIVED OR ACQUIRED.
 7. *USER'S INDEMNITY OBLIGATIONS AND REPRESENTATIONS.* USER WILL DEFEND, INDEMNIFY AND HOLD TI, ITS LICENSORS AND THEIR REPRESENTATIVES HARMLESS FROM AND AGAINST ANY AND ALL CLAIMS, DAMAGES, LOSSES, EXPENSES, COSTS AND LIABILITIES (COLLECTIVELY, "CLAIMS") ARISING OUT OF OR IN CONNECTION WITH ANY HANDLING OR USE OF THE EVM THAT IS NOT IN ACCORDANCE WITH THESE TERMS. THIS OBLIGATION SHALL APPLY WHETHER CLAIMS ARISE UNDER STATUTE, REGULATION, OR THE LAW OF TORT, CONTRACT OR ANY OTHER LEGAL THEORY, AND EVEN IF THE EVM FAILS TO PERFORM AS DESCRIBED OR EXPECTED.

8. *Limitations on Damages and Liability:*

8.1 *General Limitations.* IN NO EVENT SHALL TI BE LIABLE FOR ANY SPECIAL, COLLATERAL, INDIRECT, PUNITIVE, INCIDENTAL, CONSEQUENTIAL, OR EXEMPLARY DAMAGES IN CONNECTION WITH OR ARISING OUT OF THESE TERMS OR THE USE OF THE EVMS , REGARDLESS OF WHETHER TI HAS BEEN ADVISED OF THE POSSIBILITY OF SUCH DAMAGES. EXCLUDED DAMAGES INCLUDE, BUT ARE NOT LIMITED TO, COST OF REMOVAL OR REINSTALLATION, ANCILLARY COSTS TO THE PROCUREMENT OF SUBSTITUTE GOODS OR SERVICES, RETESTING, OUTSIDE COMPUTER TIME, LABOR COSTS, LOSS OF GOODWILL, LOSS OF PROFITS, LOSS OF SAVINGS, LOSS OF USE, LOSS OF DATA, OR BUSINESS INTERRUPTION. NO CLAIM, SUIT OR ACTION SHALL BE BROUGHT AGAINST TI MORE THAN TWELVE (12) MONTHS AFTER THE EVENT THAT GAVE RISE TO THE CAUSE OF ACTION HAS OCCURRED.

8.2 *Specific Limitations.* IN NO EVENT SHALL TI'S AGGREGATE LIABILITY FROM ANY USE OF AN EVM PROVIDED HEREUNDER, INCLUDING FROM ANY WARRANTY, INDEMNITY OR OTHER OBLIGATION ARISING OUT OF OR IN CONNECTION WITH THESE TERMS, , EXCEED THE TOTAL AMOUNT PAID TO TI BY USER FOR THE PARTICULAR EVM(S) AT ISSUE DURING THE PRIOR TWELVE (12) MONTHS WITH RESPECT TO WHICH LOSSES OR DAMAGES ARE CLAIMED. THE EXISTENCE OF MORE THAN ONE CLAIM SHALL NOT ENLARGE OR EXTEND THIS LIMIT.

9. *Return Policy.* Except as otherwise provided, TI does not offer any refunds, returns, or exchanges. Furthermore, no return of EVM(s) will be accepted if the package has been opened and no return of the EVM(s) will be accepted if they are damaged or otherwise not in a resalable condition. If User feels it has been incorrectly charged for the EVM(s) it ordered or that delivery violates the applicable order, User should contact TI. All refunds will be made in full within thirty (30) working days from the return of the components(s), excluding any postage or packaging costs.

10. *Governing Law:* These terms and conditions shall be governed by and interpreted in accordance with the laws of the State of Texas, without reference to conflict-of-laws principles. User agrees that non-exclusive jurisdiction for any dispute arising out of or relating to these terms and conditions lies within courts located in the State of Texas and consents to venue in Dallas County, Texas. Notwithstanding the foregoing, any judgment may be enforced in any United States or foreign court, and TI may seek injunctive relief in any United States or foreign court.

Mailing Address: Texas Instruments, Post Office Box 655303, Dallas, Texas 75265
Copyright © 2023, Texas Instruments Incorporated

IMPORTANT NOTICE AND DISCLAIMER

TI PROVIDES TECHNICAL AND RELIABILITY DATA (INCLUDING DATASHEETS), DESIGN RESOURCES (INCLUDING REFERENCE DESIGNS), APPLICATION OR OTHER DESIGN ADVICE, WEB TOOLS, SAFETY INFORMATION, AND OTHER RESOURCES "AS IS" AND WITH ALL FAULTS, AND DISCLAIMS ALL WARRANTIES, EXPRESS AND IMPLIED, INCLUDING WITHOUT LIMITATION ANY IMPLIED WARRANTIES OF MERCHANTABILITY, FITNESS FOR A PARTICULAR PURPOSE OR NON-INFRINGEMENT OF THIRD PARTY INTELLECTUAL PROPERTY RIGHTS.

These resources are intended for skilled developers designing with TI products. You are solely responsible for (1) selecting the appropriate TI products for your application, (2) designing, validating and testing your application, and (3) ensuring your application meets applicable standards, and any other safety, security, regulatory or other requirements.

These resources are subject to change without notice. TI grants you permission to use these resources only for development of an application that uses the TI products described in the resource. Other reproduction and display of these resources is prohibited. No license is granted to any other TI intellectual property right or to any third party intellectual property right. TI disclaims responsibility for, and you fully indemnify TI and its representatives against any claims, damages, costs, losses, and liabilities arising out of your use of these resources.

TI's products are provided subject to [TI's Terms of Sale](#), [TI's General Quality Guidelines](#), or other applicable terms available either on ti.com or provided in conjunction with such TI products. TI's provision of these resources does not expand or otherwise alter TI's applicable warranties or warranty disclaimers for TI products. Unless TI explicitly designates a product as custom or customer-specified, TI products are standard, catalog, general purpose devices.

TI objects to and rejects any additional or different terms you may propose.

Copyright © 2026, Texas Instruments Incorporated

Last updated 10/2025