

# Application Note

## DP83826A Troubleshooting Guide

---



Gerome Cacho

### Table of Contents

<b>1 DP83826A Application Overview</b>	<b>2</b>
<b>2 Troubleshooting the Application</b>	<b>2</b>
2.1 Schematic and Layout Checklist	2
2.2 Device Health Checks	3
2.2.1 Voltage Checks	3
2.2.2 Probe the RESET_N Signal	3
2.2.3 Probe RBIAS and CEXT	3
2.2.4 Probe the XI Clock	5
2.2.5 Probe the Strap Pins During Initialization	6
2.2.6 Probe the Serial Management Interface Signals (MDC, MDIO)	8
2.3 MDI Health Checks	10
2.3.1 Magnetics	10
2.3.2 Probe the MDI Signals	10
2.3.3 Link Quality Check	11
2.3.4 Compliance	12
2.4 MII Health Checks	13
2.4.1 MII Check	13
2.4.2 RMII Check	15
2.5 Loopback and PRBS	18
2.5.1 Loopback Modes	18
2.5.2 Transmitting and Receiving Packets With the MAC	19
2.5.3 Transmitting and Receiving Packets With BIST	19
<b>3 Summary</b>	<b>20</b>
<b>4 References</b>	<b>21</b>

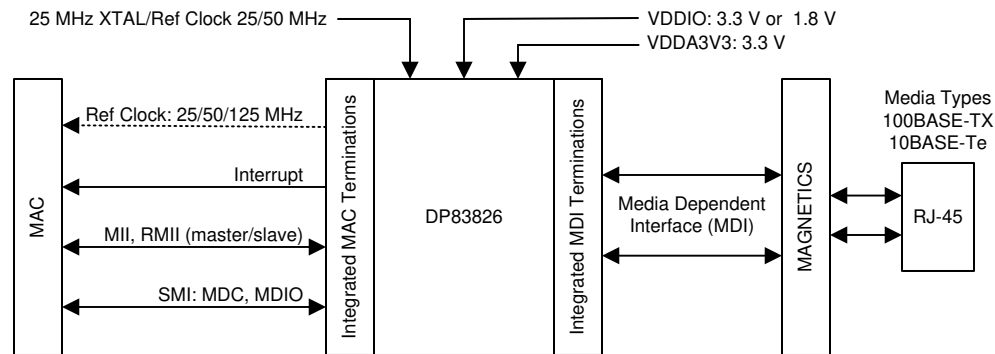
### Trademarks

All trademarks are the property of their respective owners.

## 1 DP83826A Application Overview

The DP83826A offers low and deterministic latency, low power, and supports 10BASE-Te, 100BASE-TX Ethernet protocols to meet stringent requirements in real-time industrial Ethernet systems. The device includes hardware bootstraps to achieve fast link-up time, fast link-drop detection modes, and dedicated reference CLKOUT to clock synchronize other modules on the systems.

Figure 1-1 is a high-level system block diagram of a typical DP83826A application.



**Figure 1-1. DP83826A Block Diagram**

The DP83826A connects between an Ethernet MAC and the media through MDI. The connection to the media is typically through magnetics and a connector such as an RJ-45.

## 2 Troubleshooting the Application

The following sections approach the debug from a high level, basic check approach which isolates subsystems of the PHY design to check if they contribute to an application issue.

This document is intended to address common Ethernet issues such as:

- Inability to ping
- Cannot get link OR intermittent linkup
- Linkup but seeing packet errors
- Cannot access registers

The recommendation is to go through the following sections in order unless otherwise specified.

### 2.1 Schematic and Layout Checklist

[DP83826A Schematic Checklist](#) TI file compiles the best practices for designing with DP83826A into a single, easy-to-use document. The recommendation is to go through this document for more detailed description what connections and components are needed for the PHY to work.

The following sections can present expected behaviors if the PHY is powered and initialized correctly. Any deviations from expected behaviors can point to errors due to incorrect peripheral circuitry.

## 2.2 Device Health Checks

This section dives into device health checks which makes sure the device is powered and initialized correctly. This section can be skipped if DP83826A is:

- Linking up (LED indication or register status) when connected to link partner OR showing FLP signals when Ethernet cable is unconnected, AND
- Responding to register access (if applicable)

### 2.2.1 Voltage Checks

DP83826A need to have sufficient power supplied as well as the following decoupling scheme that has been characterized for the device:

- Per rail
  - 1x 10nF, 1x 100nF, 1x 1uF, 1x 10uF

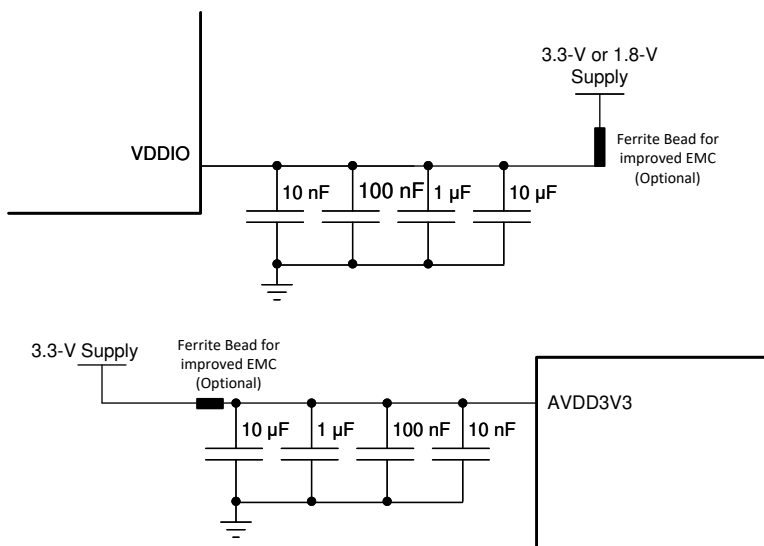


Figure 2-1. Power Supply Decoupling Recommendation

Power up the device and perform DC measurement of the supplies as close to the pin as possible. Confirm that each measurement is within the limits defined in [Table 2-1](#).

Table 2-1. Recommended Operating Conditions

	Min	Typ	Max	Unit
AVDD3V3	3	3.3	3.6	V
VDDIO (3.3V)	3	3.3	3.6	
VDDIO (1.8V)	1.62	1.8	1.98	

### 2.2.2 Probe the RESET\_N Signal

The reset functionality on DP83826A is active low. This pin has a weak internal pull-up resistor to provide a default state if left unconnected or not driven externally.

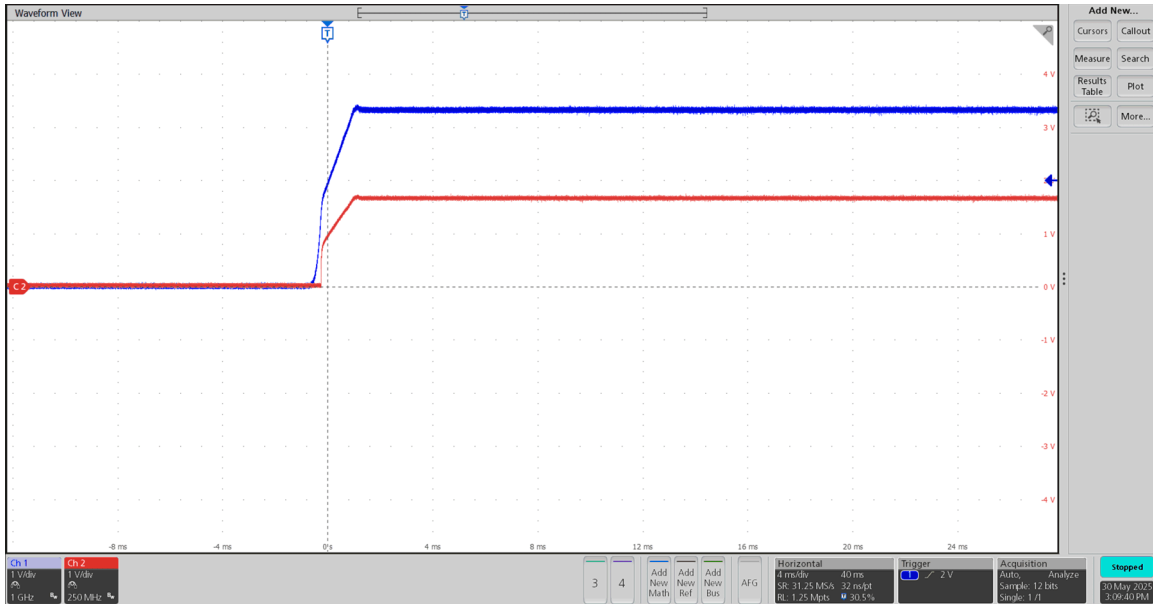
Confirm that the controller is not driving the RESET\_N signal low. Otherwise, the device can be held in reset state, and does not respond to register commands or can link up.

### 2.2.3 Probe RBIAS and CEXT

The RBIAS pin is critical to PHY operation. This component is used to set the internal reference current within the device. The guidance for component selection is a single 6.49kΩ component that has a 1% tolerance for RBIAS. The preference is to have a single component over multiple in series as the tolerance range can increase.

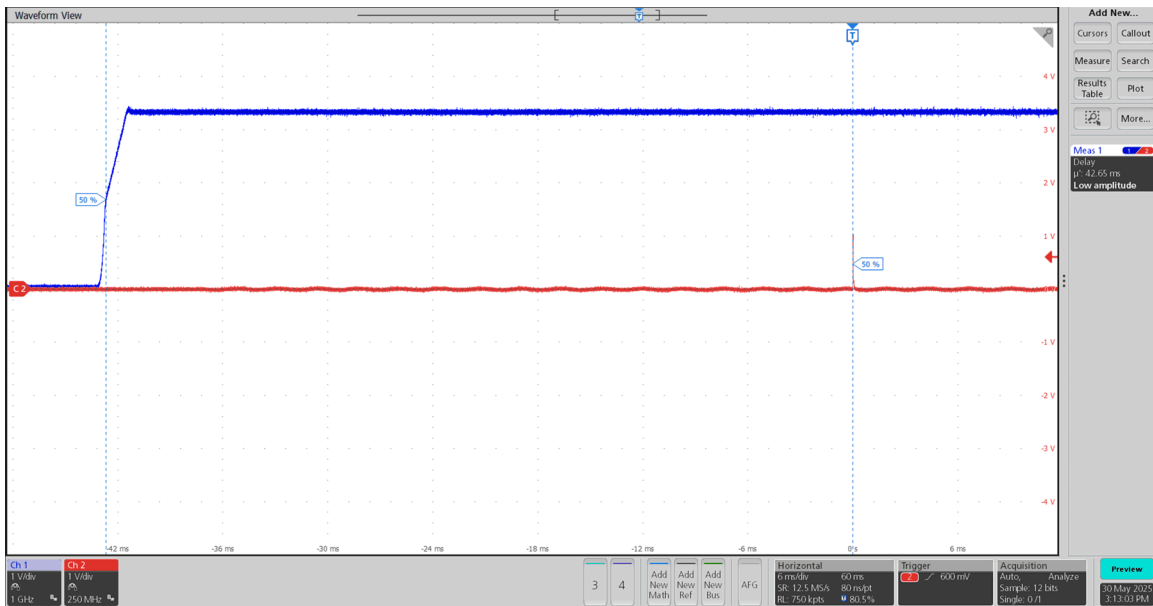
If properly powered, a 1V signal can appear when probing the RBIAS pin for approximately 60us after power ramp before going back to 0V. CEXT needs to present a 1.7V signal while device is active.

CH 1 (3.3V Supply), CH 2 (CEXT)



**Figure 2-2. DP83826A CEXT Ramp**

CH 1 (3.3V Supply), CH 2 (RBIAS). Notice pulse at trigger point



**Figure 2-3. DP83826A RBIAS Pulse Delay vs VDDA3V3 Ramp**

CH 1 (3.3V Supply), CH 2 (RBIAS)

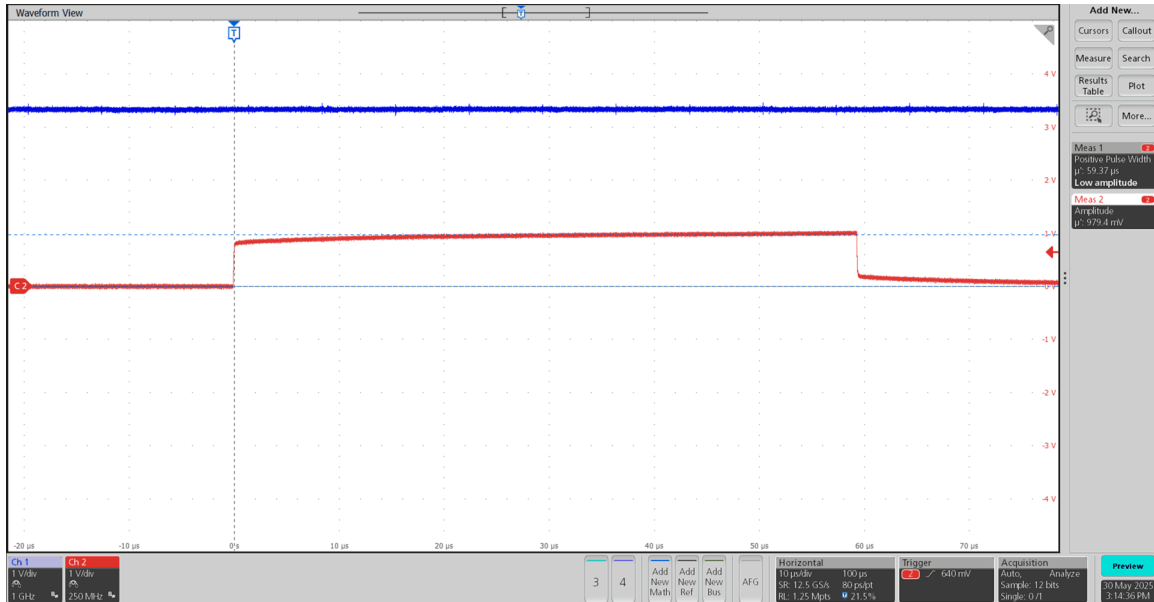


Figure 2-4. DP83826A RBIAS Pulse Width

### 2.2.4 Probe the XI Clock

The following guidelines are the main specifications to reference for compatible crystals.

Table 2-2. 25MHz Crystal Specifications

PARAMETER	TEST CONDITION	MIN	TYP	MAX	UNIT
Frequency			25		MHz
Frequency Tolerance	Operational Temperature	-100		100	ppm
Load Capacitance			15	40	pF
ESR				50	Ω

Table 2-3. 25MHz Oscillator Specifications

PARAMETER	TEST CONDITION	MIN	TYP	MAX	UNIT
Frequency			25		MHz
Frequency Tolerance	Operational Temperature			±50	ppm
Frequency Stability	1 year aging			±50	ppm
Rise / Fall Time	20% - 80%			5	ns
Symmetry	Duty Cycle	40%		60%	
Jitter RMS	Integration Band: 12kHz to 5MHz			11	ps

Verify the frequency and signal integrity. For link integrity the reference clock must be:

- MII and RMII leader modes
  - 25MHz ±50ppm
- RMII follower mode
  - 50MHz ±50ppm

If using a crystal as the clock source, the recommendation is to probe the CLK\_OUT signal. Probing on the crystal nodes can change the capacitive loading and therefore change the operational frequency.

**Note**

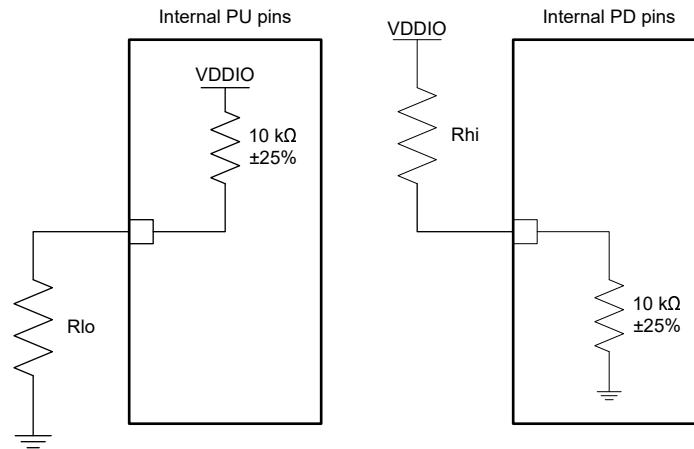
For more information on designing with a crystal network, please refer to [Selection and specification of crystals for Texas Instruments ethernet physical layer transceivers](#), application note.

The default signal on CLK\_OUT is a buffered version of the XI reference and will provide a representative measurement. If CLK\_OUT is either not available due to strapping or is unexpectedly absent, XI pin can have to be probed but results must be taken lightly.

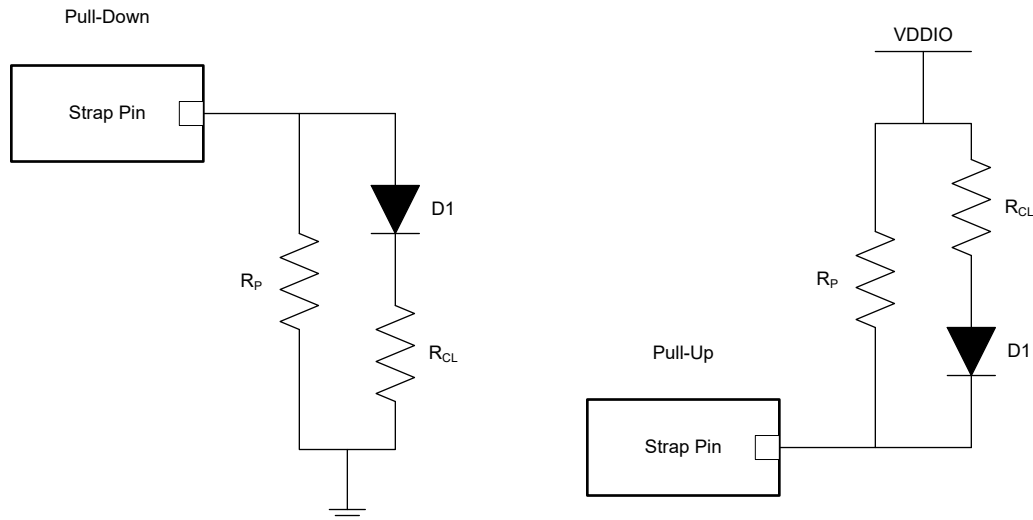
**2.2.5 Probe the Strap Pins During Initialization**

The PHY has strap pins which assist with configuring the device in a predetermined mode. The voltage at these pins is the sole determining factor as to whether or not the device is in one mode or the other.

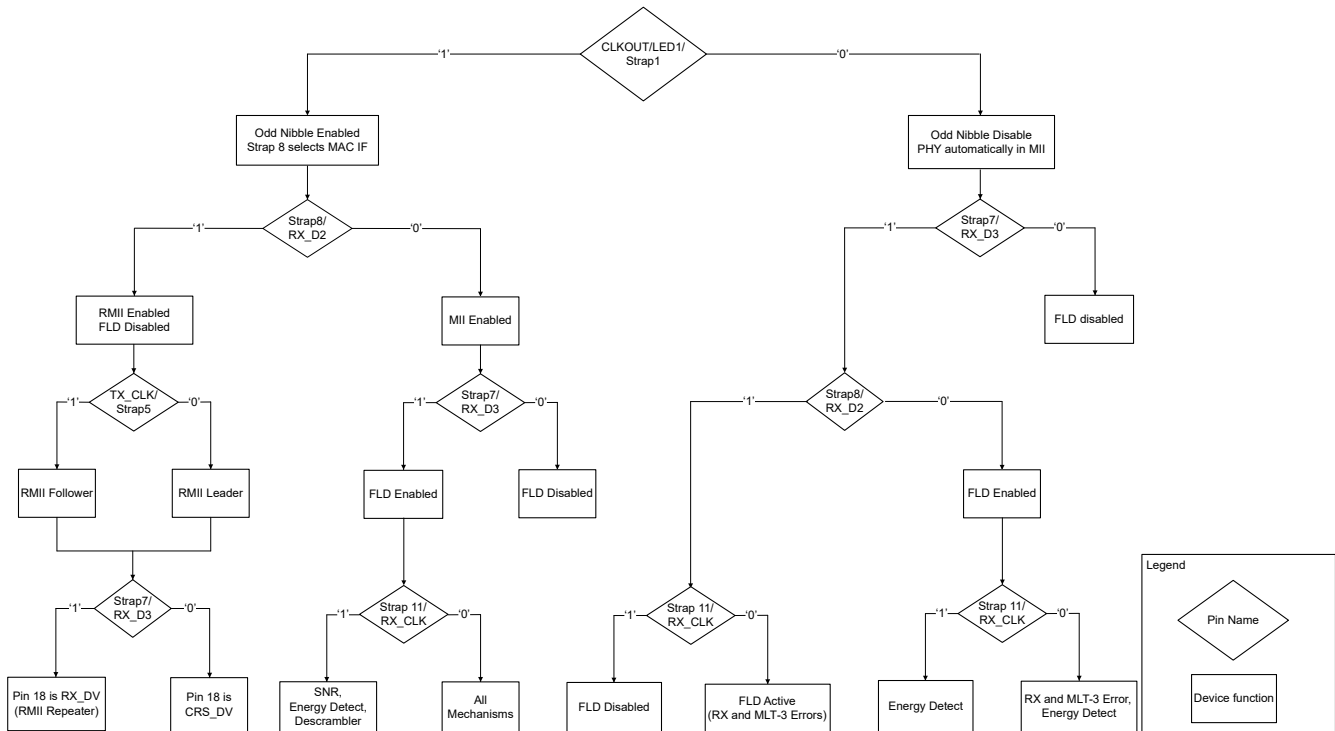
The expectation during the sampling time for strapping is that the external strap network (consisting of a PU or PD resistor, if applicable) along with the internal resistor creates a voltage divider in which the PHY samples. No other component on the line need to affect the DC bias set by this network.



**Figure 2-5. DP83826A Strap Circuit**



**Figure 2-6. DP83826A LED Strap Circuit**



**Figure 2-7. DP83826A Enhanced Strap Flowchart**

However, in some cases, other devices on the board (for example, the MAC) will pull or drive these pins unexpectedly. The strap values can be read from the registers. The values are available in Reg 0x0467 (SOR1) and Reg 0x0468 (SOR2). If there is power cycle dependency to an issue, the strapping can be marginal and can be observed cycle to cycle against these registers to determine if the PHY is strapped in an unintended state.

Measurements can be made during power up and after power up when the RESET\_N signal is asserted.

## 2.2.6 Probe the Serial Management Interface Signals (MDC, MDIO)

### 2.2.6.1 Read and Check Register Values

If applicable, Station Management Interface can be useful in providing valuable status fields during a debug. However, verify that this communication is accurate to avoid compounding issues. Make sure that MDIO has a pull up resistor to VDDIO as this pin is an open-drain to the PHY. When idle, the voltage needs to be VDDIO. Make sure the SMI access follows the following sequence:

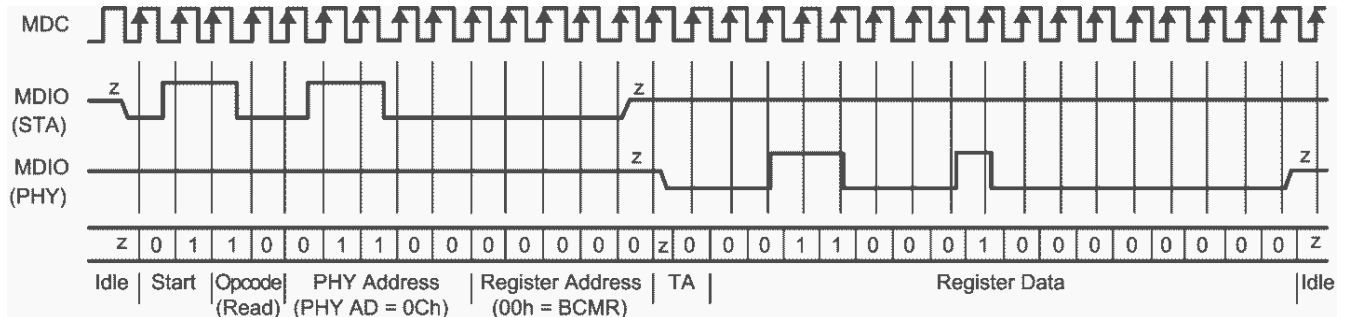


Figure 2-8. SMI Read Operation

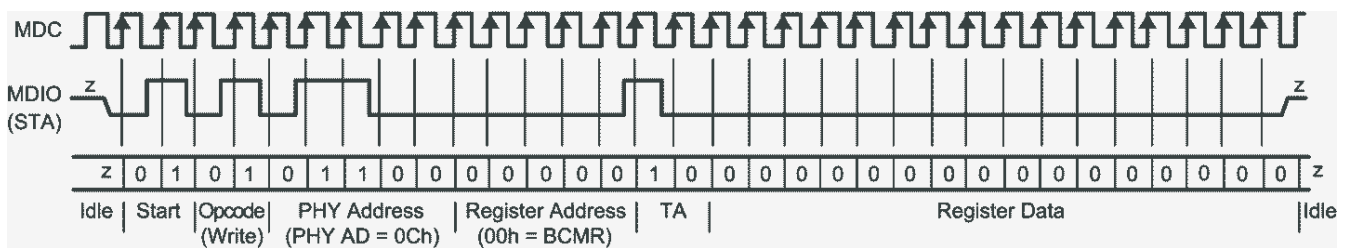


Figure 2-9. SMI Write Operation

Read the registers and verify the default values shown in the data sheet. Note that the initial values of some registers can vary based on strap options. The expected register values for PHY operation and link in 10/100 Mbps with auto-negotiation enabled are shown in Table 2-4.

Table 2-4. DP83826A Register Value References

REGISTER ADDRESS	REGISTER VALUE		Comments
	10Mbps	100Mbps	
0x0000	3100		Auto-Negotiation Control, MII Loopback
0x0001	786D		Link Status
0x0003	A1x6		PHY Revision A111 = Basic A131 = Enhanced
0x0004	0041	01E1	DUT 10/100Mbps advertisement
0x0005 <sup>1</sup>	41E1		LP 10/100Mbps advertisement
0x000A	0100		Odd Nibble Detection (EtherCAT)
0x000B	0000		Fast Link Drop Configuration
0x0010 <sup>2</sup>	4717 or 0017	4715 or 0715	PHY Status
0x0011	0108		PWDN/INT
0x0014	0000		False Carrier Counter
0x0015	0000		RX Error Counter
0x0017	0041		RMII Configuration
0x0019	C000	CC00	MDI(x) Configuration



With the PHY linked in a given speed, use these values as a reference to identify any variance from the expected operation. Note that not all registers need to be the same, for example:

**Example:** After powering and linking the PHY in 10Mbps, Reg 0x10 is read at Reg 0x17. Meaning Bits [4, 2, 1, 0] are high. These bits confirm: Auto-Negotiation is complete, Full-Duplex, 10Mbps Mode, and valid link established.

Repeating this process for any values distinct from the expected values shown in [Table 2-4](#) help diagnose the exact state of the PHY for any encountered issues.

#### **2.2.6.1.1 Extended Register Access**

To read and write registers in extended register space, refer to the following procedures:

*Write procedure for MMD 1F registers:*

```
write reg<000D> = 0x001F
```

```
write reg<000E> = <address>
```

```
write reg<000D> = 0x401F
```

```
write reg<000E> = <value>
```

*Read procedure for MMD 1F registers:*

```
write reg<000D> = 0x001F
```

```
write reg<000E> = <address>
```

```
write reg<000D> = 0x401F
```

```
read reg<000E>
```

---

#### **Note**

The previous write and read procedure is normally used for registers with address outside of 0x0 - 0x1F, but can be used for any address in general

---

## 2.3 MDI Health Checks

This section dives into device health checks which makes sure that the MDI device section is operating properly. This section can be skipped if DP83826A is:

- Linked up AND reporting no packet errors through Reg 0x15 when sending traffic through the device

### 2.3.1 Magnetics

The following guidelines are the main specifications to reference for compatible magnetics:

**Table 2-5. Magnetic Isolation Requirements**

Parameter	Test Conditions	TYP	UNIT
Turns Ratio	±2% Tolerance	1:1	-
Insertion Loss	1-100MHz	-1	dB
Return Loss	1-30MHz	-16	dB
	30-60MHz	-12	dB
	60-80MHz	-10	dB
Differential to Common Mode Rejection Ratio	1-50MHz	-30	dB
	50-150MHz	-20	dB
Crosstalk	30MHz	-35	dB
	60MHz	-30	dB
Isolation	HPOT	1500	Vrms

If these exact requirements cannot be met, the following allowances can be made.

- Turns ratio
  - 2% is designed for, but 3% is tolerable.
- Inductance
  - High inductance is preferred. Usual numbers seen are around 350µH.
- Insertion loss
  - As close to 0dB as possible compared to specified value for each range stated in data sheet. If specification gives -1dB as typical, finding a component with -1dB, -0.9dB, is recommended.
- Return loss
  - At or lower than the magnitude specified in data sheet. If specification gives -16dB as typical, finding a component with -16dB, -17dB, ... is recommended.

### 2.3.2 Probe the MDI Signals

In the default configuration, Auto-negotiation and Auto-MDIX can be enabled. A link pulse needs to be visible on the channel transmit (TD\_P, TD\_M) and will occasionally toggle to the receive pair (RD\_P, RD\_M). If set to MDI, this pulse is only available on the transmit pair while if set in MDI-X, this is only available on the receive pair.

A short Ethernet cable terminated with 100 Ohm differential needs to be used for measuring the MDI signals. A terminated cable is shown in [Figure 2-10](#). A connection diagram for making measurements with the terminated cable is shown in [Figure 2-11](#).

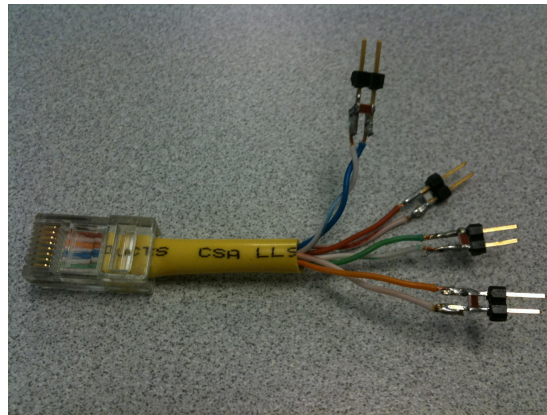


Figure 2-10. 100Ω Terminated Cable for MDI Signal Measurement

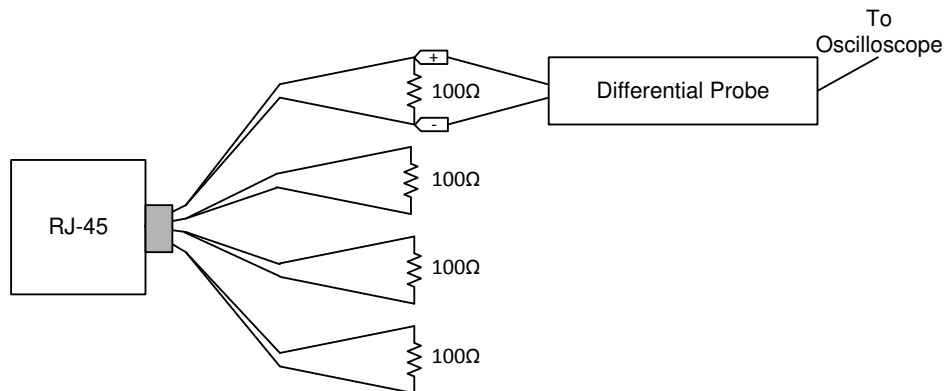


Figure 2-11. Connection Diagram for 100M Terminated Cable

Auto-Negotiation link pulses are nominally 100ns wide. Pulses are spaced by 62μs or 125μs and are transmitted in bursts. The bursts are nominally 2ms in duration and occur every 16ms. Figure 2-12 shows a link pulse.

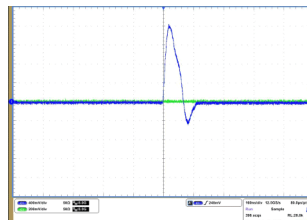


Figure 2-12. DP83826A Link Pulse

### 2.3.3 Link Quality Check

After establishing a valid link, confirming the key status register values and visually verifying that the link LED is lit, the next data transfer debug step is to check the MAC Interface.

There are several possible sources of link problems:

1. Link partner transmit problem
2. Cable length and quality
3. Clock quality of the 25MHz reference clock
4. MDI signal quality

With the PHY powered and connected to a link partner, the following registers can be read from to determine the health of the link:

**Table 2-6. Link Quality MSE Register**

CHANNEL	REGISTER ADDRESS
A	0x225

For a given channel, read the register value to determine the MSE (Mean Square Error), convert to decimal, and refer to [Table 2-7](#) to determine link quality:

$$SNR(dB) = 10\log(0.5) - 10\log\left(\frac{MSE}{2^{17}}\right)$$

**Table 2-7. Link Quality Ranges**

LINK QUALITY	SNR RANGE
Excellent	SNR > 22dB
Good	19.5dB < SNR < 22dB
Poor	SNR < 19.5dB

### 2.3.4 Compliance

IEEE compliance measurements can be made to verify the signaling characteristics. For details on these measurements and how to properly configure, please refer to the application note [How to Configure DP8382x for Ethernet Compliance Testing](#).

## 2.4 MII Health Checks

This section dives into device health checks which makes sure that the device's MII section is operating properly.

### 2.4.1 MII Check

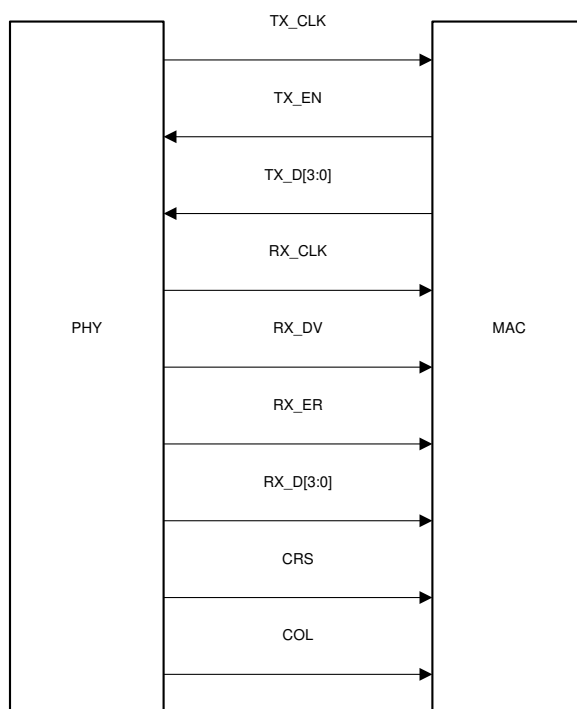
The Media Independent Interface (MII) is a synchronous 4-bit wide nibble data interface that connects the PHY to the MAC. The MII is fully compliant with IEEE 802.3-2002 clause 22.

MII is set by default in the PHY with Hardware Strap 8 RX\_D2 = '0'. Reg 0x0467[8] can confirm the status of strap 8 (High or Low), and Reg 0x0468[4] can confirm the PHY initial MAC Mode (MII = 0 | RMII = 1).

The MII signals are summarized below:

**Table 2-8. MII Signals**

Function	Pins
Data Signals	TX_D[3:0]
	RX_D[3:0]
Transmit and Receive Signals	TX_EN
	RX_DV
Line-Status Signals	CRS
	COL
Error Signals	RX_ER



**Figure 2-13. MII Signaling**

Reference the waveforms below to verify the expected MAC data and clock signals for 100BASE-Tx MII Mode. [Table 2-9](#) displays specs taken from the data sheet shown in the waveforms. MII signaling needs to be 2.5MHz if PHY is not linked up or linked up at 10Mbps, and needs to be at 25MHz if linked at 100Mbps. Note that both TX\_CLK and RX\_CLK are outputs of the PHY.

If a MAC bus (TX or RX) is suspected to be problematic, probe the lines at the receiver side of the trace, making sure that the receiver's setup and hold times are met, along with VIH/VIL. Typical symptoms of violating these specifications is packet errors at the MAC while the PHY is indicating clean traffic (Reg 0x15).

**Table 2-9. 100M MII Receive Timing**

Test Condition	MIN	TYP	MAX	Unit
RX_CLK High / Low Time	16	20	24	ns
RX_D[3:0], RX_ER, RX_DV Delay from RX_CLK rising	20		28	ns

**Table 2-10. 100M MII Transmit Timing**

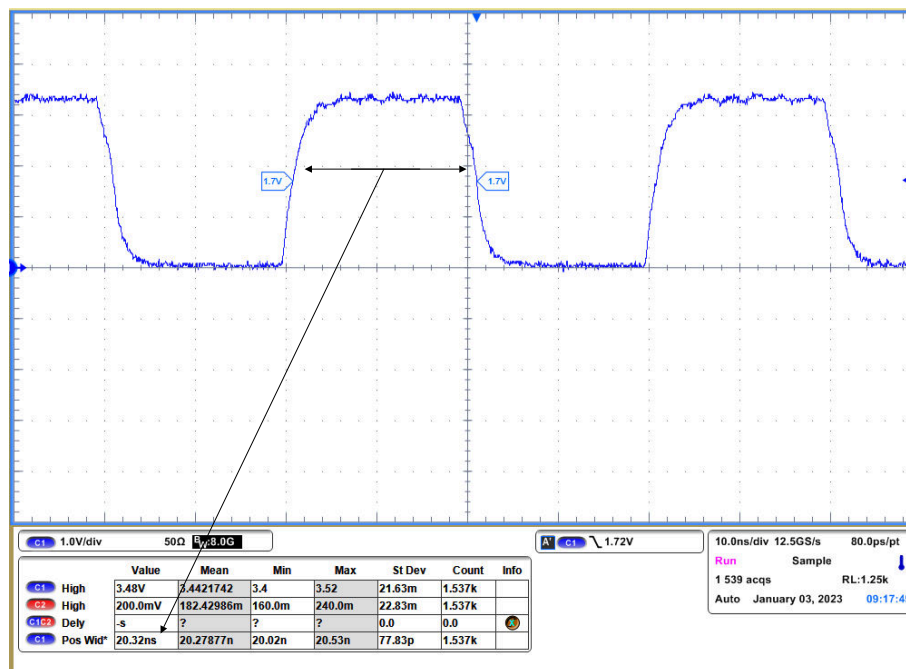
TEST CONDITION	MIN	TYP	MAX	UNIT
TX_CLK High / Low Time	16	20	24	ns
TX_D[3:0], TX_ER, TX_EN Setup to TX_CLK	10			ns
TX_D[3:0], TX_ER, TX_EN Hold from TX_CLK	0			ns

**Table 2-11. 10M MII Receive Timing**

TEST CONDITION	MIN	TYP	MAX	UNIT
RX_CLK High / Low Time	160	200	240	ns
RX_D[3:0], RX_ER, RX_DV Delay from RX_CLK rising	100		300	ns

**Table 2-12. 10M MII Transmit Timing**

TEST CONDITION	MIN	TYP	MAX	UNIT
TX_CLK High / Low Time	190	200	240	ns
TX_D[3:0], TX_ER, TX_EN Setup to TX_CLK	25			ns
TX_D[3:0], TX_ER, TX_EN Hold from TX_CLK	0			ns


**Figure 2-14. 100M RX\_CLK High Time**

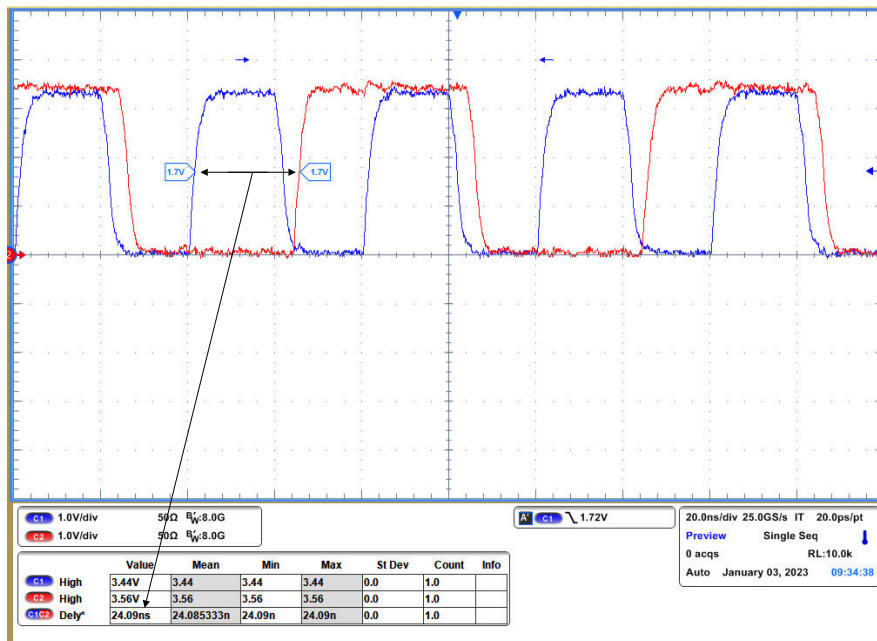


Figure 2-15. 100M RX\_D1 Delay From RX\_CLK Rising

## 2.4.2 RMII Check

Reduced Media Independent Interface, as specified in the RMII specification v1.2, provides a reduced pin count alternative to the IEEE 802.3 MII as specified in Clause 22. Architecturally, the RMII specification provides an additional reconciliation layer on either side of the MII, but can be implemented in the absence of an MII. The DP83826 offers two types of RMII operations: RMII Leader and RMII Follower.

In RMII Leader operation, the DP83826 operates from either a 25MHz CMOS-level oscillator connected to XI pin or a 25MHz crystal connected across XI and XO pins. A 50MHz output clock referenced from DP83826 needs to be connected to the MAC.

In RMII Follower operation, the DP83826 operates from a 50MHz CMOS-level oscillator connected to the XI pin and shares the same clock as the MAC. Alternatively, the PHY can operate from a 50MHz clock provided by the Host MAC.

The RMII specification has the following characteristics:

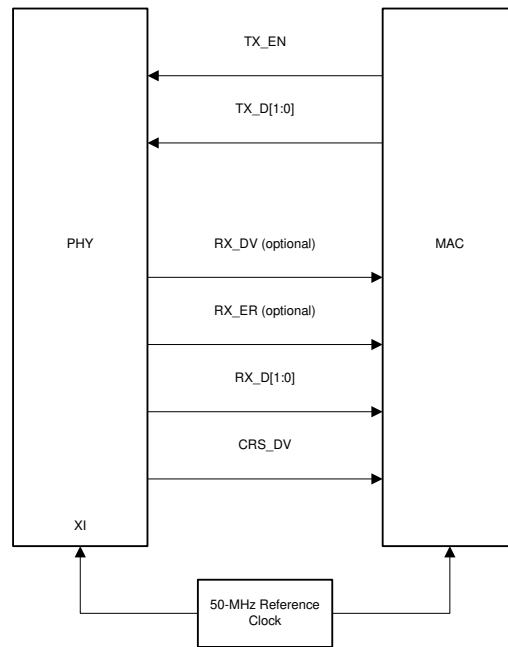
- Supports 100BASE-TX and 10BASE-Te
- Single clock reference sourced from the MAC to PHY (or from an external source)
- Provides independent 2-bit wide transmit and receive data paths
- Uses CMOS signal levels, the same levels as the MII interface

RMII can be set with pulling up Hardware Strap 8  $RX\_D2 = 1$ . Reg 0x0467[8] can confirm the Status of Strap 8 (High or Low) and Reg 0x0468, can confirm the PHY's MAC Mode (MII = 0 | RMII = 1).

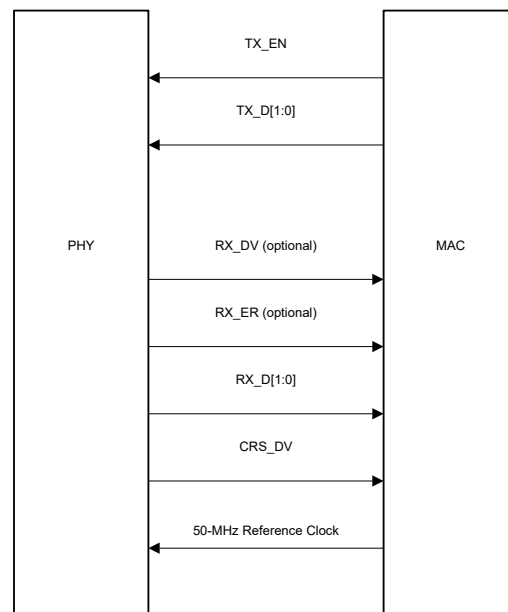
In this mode, data transfers are 2 bits for every clock cycle using the internal 50MHz reference clock for both transmit and receive paths. The RMII signals are summarized below:

Table 2-13. RMII Signals

FUNCTION	PINS
Receive data lines	TX_D[1:0]
Transmit data lines	RX_D[1:0]
Receive control signal	TX_EN
Transmit control signal	CRS_DV

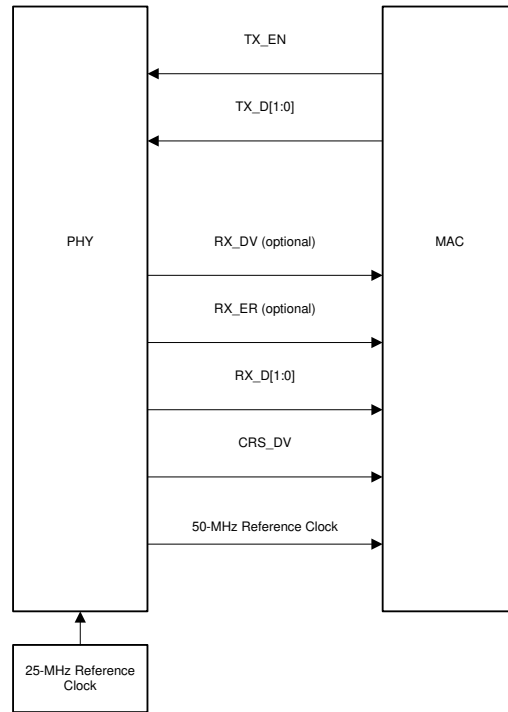


**Figure 2-16. RMII Follower Signaling - MAC Follower Configuration**



**Figure 2-17. RMII Follower Signaling - MAC Leader Configuration**

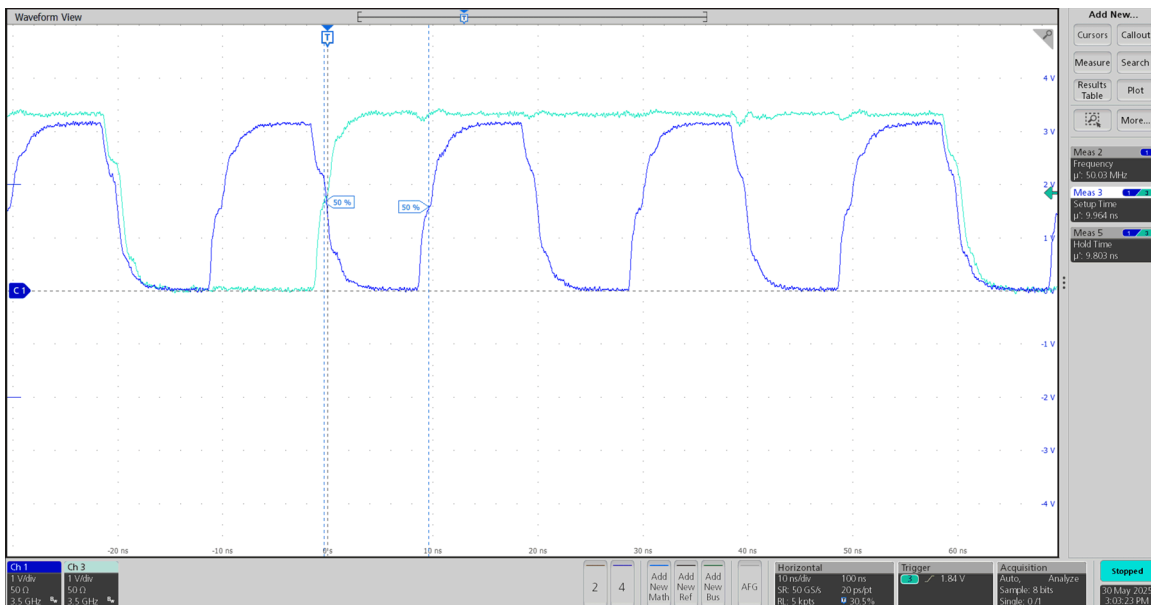




**Figure 2-18. RMI Leader Signaling**

Data on TX\_D[1:0] are latched at the PHY with reference to the 50MHz-clock in RMI Leader mode and Follower mode. Data on RX\_D[1:0] is provided in reference to 50MHz clock. In addition, CRX\_DV can be configured as RX\_DV signal. This allows a simpler method of recovering receive data without the need to separate RX\_DV from the CRS\_DV indication.

CH 1 (RMII 50MHz Clock), CH 2 (RX\_D0)



**Figure 2-19. RMII Clock and Data**

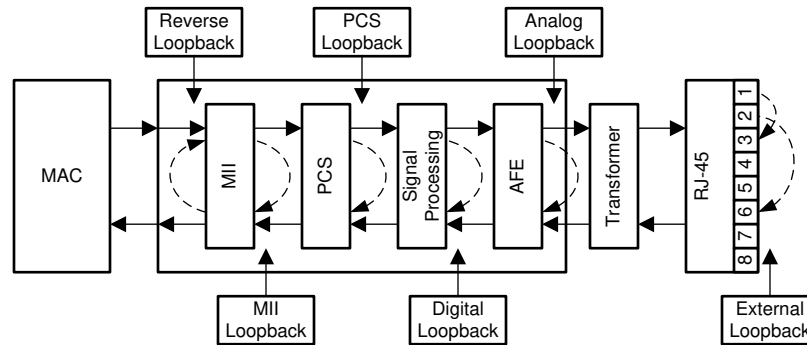
## 2.5 Loopback and PRBS

### 2.5.1 Loopback Modes

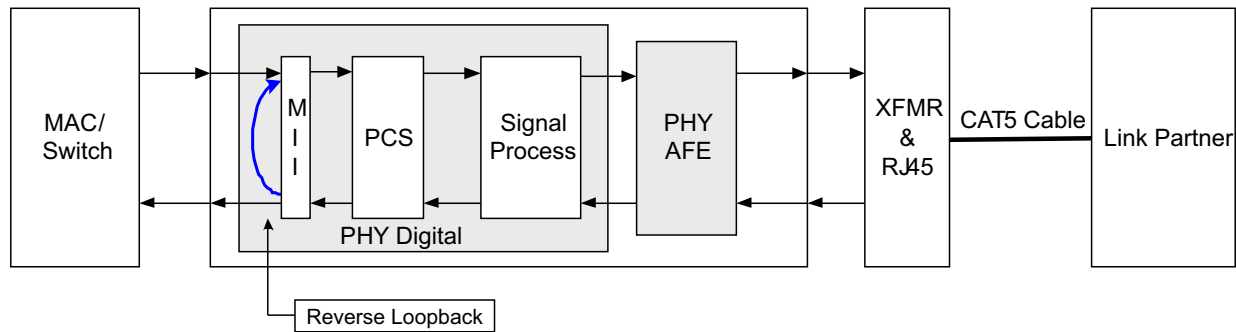
There are several options for loopback that test and verify various functional blocks within the PHY. Enabling loopback mode allows in-circuit testing of the MII and MDI data paths. DP83826 can be configured to one of the Near-end loopback modes or to the Far-end (reverse) loopback.

MII Loopback is configured using the BMCR (Reg 0x0). All other loopback modes are enabled using the BSCR (Reg 0x16). Loopback modes are supported for all speeds (10/100) and all MAC interfaces.

Figure 2-20 illustrate the various data paths that each loopback mode can be used to verify:



**Figure 2-20. Loopback Modes Block Diagram**



Copyright © 2016, Texas Instruments Incorporated

**Figure 2-21. Reverse Loopback Mode Block Diagram**

Analog loopback is typically used to verify the PHY's full internal data path, while reverse loopback is used with a link partner to verify the data path along the MDI.

```
// Digital Loopback
begin
0000 2100 //Disables Auto-Neg, Selects 100 Mbps
0016 0104 //Select Digital Loopback
0122 2000 //This helps PRBS LOCK
0123 2000 //This helps PRBS LOCK
0130 47FF //This helps PRBS LOCK
001F 4000 //Soft Reset
end
```

```
// Reverse Loopback
begin
0016 0110 //Select Digital Loopback
001F 4000 //Soft Reset
end
```

### 2.5.2 Transmitting and Receiving Packets With the MAC

If generating and checking packets with the MAC is possible, and the PHY has a working link partner with reverse loopback capability, verify the full data path as follows:

1. Power and connect the PHY to the MAC and a working link partner.
2. Enable reverse loopback on the link partner (for DP83826A link partner, write Reg 0x16 to 0010).
3. Transmit test packets from the MAC to the PHY.
4. Verify the MAC receives the same test packets.

If the MAC receives the same test packets transmitted without issue, the full data path through MAC → PHY → MDI is valid. If this test does not pass, perform MII loopback to isolate the issue along the data path:

1. Power and connect the PHY to the MAC.
2. Enable MII loopback on the PHY (write Reg 0x0[14] = '1').
3. Transmit test packets from the MAC to the PHY.
4. Verify the MAC receives the same test packets.

If the MAC receives the same test packets, the data path through MAC → PHY is valid, and the issue has been isolated to the MDI data path. If this test does not pass, the issue can be on the MAC interface or the internal data path. To verify the MAC interface, refer to Debugging MAC Interface. To verify the internal data path, perform PRBS with analog loopback using the following script.

### 2.5.3 Transmitting and Receiving Packets With BIST

The device incorporates an internal PRBS Built-in Self Test (BIST) circuit to accommodate in-circuit testing or diagnostics. The BIST circuit can be used to test the integrity of the transmit and receive data paths. BIST can be performed using various loopback modes to isolate any issues to specific parts of the data path. The BIST generates packetized data with variable content and IPG.

If generating and checking packets with the MAC is not possible, use PRBS packet generation and checking functionality to verify the data path.

Perform reverse loopback with PRBS and a working link partner as follows:

1. Power and connect the PHY to a link partner.
2. Enable PRBS packet generation on the PHY (write Reg 0x16 to 5000).
3. Enable reverse loopback on the link partner (for DP83826A link partner, write Reg 0x16 to 0010).
4. Wait at least one second, then check PRBS lock status on the PHY (read Reg 0x16[11:10]).

If register 0x16[11] is high, the data path through PHY → MDI is valid. If this test does not pass, the issue can be on the PHY's internal data path or the MDI. To verify the internal data path, perform PRBS with analog loopback using the following script. If the internal data path is valid, then the issue is isolated to the MDI (assuming the link partner is working).

Following is an example sequence of register reads and writes to perform BIST with Analog Loopback in 100Mbps:

```
// Analog Loopback
begin
0000 2100 //Disables Auto-Neg, Selects 100 Mbps
0016 0108 //Select Analog Loopback
030B 3380 //This helps PRBS LOCK
001F 4000 //Soft Reset

0010      // LSB '5' expected.

0016 3108 //Enables PRBS Checker Config & Packet Generation Enable
        //After you write '3108' the register should Read 3b04. (Bit 11 & 9 go high)
001B 807D //Lock Error Counter's value
001B
end
```

```
//DP83826A Digital Loopback 100Mbps PRBS Packet Generator
begin

0000 2100 //Disable Auto Negotiation and Chooses 100 Mbps
0016 0104 //Enable Digital Loopback
0122 2000
0123 2000
0130 47FF
001F 4000 //Soft Reset

0010      //Bit 0 = '1' confirms Link (No Link expected for 10 Mbps)
        //Bit 1 = '0' confirms 100 Mbps Speed

0016 3104 //Enables PRBS Checker Config & Packet Generation Enable
        //After you write '3104' the register should Read 3b04. (Bit 11 & 9 go high)
001B 807D //Lock Error Counter's Value
001B
end
```

#### Note

The best practice is to include a hard reset (Reg 0x0[15]) at the beginning of each script in debugging to make sure prior configurations do not affect results.

### 3 Summary

This application note provides a suggested flow for evaluating a new application and confirming the expected functionality. The step-by-step recommendations can help ease board bring up and initial evaluation of DP83826 designs.

## 4 References

- Texas Instruments, [How to Configure DP8382x for Ethernet Compliance Testing](#), application note.
- Texas Instruments, [How to Pass IEEE Ethernet Compliance Tests](#), application note.

## IMPORTANT NOTICE AND DISCLAIMER

TI PROVIDES TECHNICAL AND RELIABILITY DATA (INCLUDING DATA SHEETS), DESIGN RESOURCES (INCLUDING REFERENCE DESIGNS), APPLICATION OR OTHER DESIGN ADVICE, WEB TOOLS, SAFETY INFORMATION, AND OTHER RESOURCES "AS IS" AND WITH ALL FAULTS, AND DISCLAIMS ALL WARRANTIES, EXPRESS AND IMPLIED, INCLUDING WITHOUT LIMITATION ANY IMPLIED WARRANTIES OF MERCHANTABILITY, FITNESS FOR A PARTICULAR PURPOSE OR NON-INFRINGEMENT OF THIRD PARTY INTELLECTUAL PROPERTY RIGHTS.

These resources are intended for skilled developers designing with TI products. You are solely responsible for (1) selecting the appropriate TI products for your application, (2) designing, validating and testing your application, and (3) ensuring your application meets applicable standards, and any other safety, security, regulatory or other requirements.

These resources are subject to change without notice. TI grants you permission to use these resources only for development of an application that uses the TI products described in the resource. Other reproduction and display of these resources is prohibited. No license is granted to any other TI intellectual property right or to any third party intellectual property right. TI disclaims responsibility for, and you will fully indemnify TI and its representatives against, any claims, damages, costs, losses, and liabilities arising out of your use of these resources.

TI's products are provided subject to [TI's Terms of Sale](#) or other applicable terms available either on [ti.com](#) or provided in conjunction with such TI products. TI's provision of these resources does not expand or otherwise alter TI's applicable warranties or warranty disclaimers for TI products.

TI objects to and rejects any additional or different terms you may have proposed.

Mailing Address: Texas Instruments, Post Office Box 655303, Dallas, Texas 75265  
Copyright © 2025, Texas Instruments Incorporated