

EVM User's Guide: AWRL6844EVM IWRL6844EVM

AWRL6844/IWRL6844 Evaluation module



Description

The xWRL6844EVM from Texas Instruments is an easy-to-use evaluation module for the xWRL6844 mmWave radar sensor. The xWRL6844EVM supports both standalone operation as well as direct connectivity to the DCA1000EVM for raw ADC capture and offline signal processing development. This EVM contains everything required to start developing software for on-chip DSP, Hardware accelerator and low power ARM® Cortex® - R5F controller. The EVM also includes on-board buttons, LEDs for quick integration of a simple user interface in addition to onboard emulation for programming and debugging.

Features

- 57GHz to 64GHz mmWave radar sensor
- On-Chip C66x DSP, ARM CORTEX-R5F controller and Hardware Accelerator (HWA 1.2)
- Onboard four-transmit and four-receive antennas (4TX/4RX) with High RF performance RO3003 PCB substrate
- TPS650365x based power management topology
- Direct interface with DCA1000 for debug and Raw ADC data capture.
- Onboard 2 x CAN-FD and 1 x LIN PHY transceivers

Getting Started

For getting started guide and running out of box demo, please refer to [SWRU636](#)

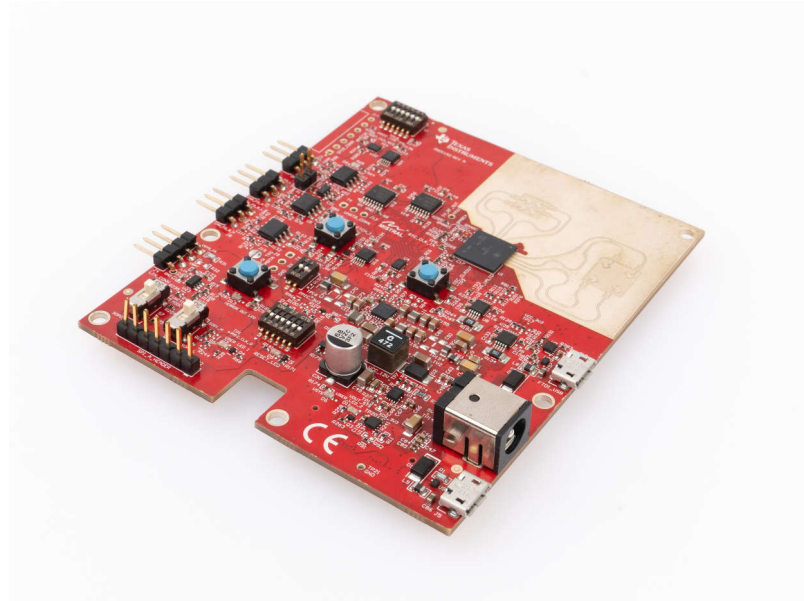

Figure 1-1. xWRL6844EVM

1 xWRL6844EVM Revision history

Table 1-1. xWRL6844EVM revision history

Revision	Changes	Notes
Rev A1		B0 version of PMIC used with Watch Dog enable
Rev A Assy Rev A12	R87 DNP	B0 version of PMIC used with Watch Dog enable. R87 was removed to increase PMIC shutdown window time
Rev A Assy Rev A23	PMIC silicon change	B1 version of PMIC used with Watch Dog disable

1. PMIC WatchDog is enabled in this EVM version. Hence, PMIC asserts a nRESET signal to Radar device for every 13minutes from EVM power-up if WatchDog is not disabled/serviced in a timely manner
2. PMIC WatchDog is enabled in this EVM version and R87 is made DNP. This ensures no connection between nRESET signal going to radar device. Radar device will not see a reset for every 13mins, but PMIC shutdowns for every 3.25hrs from the powerup
3. PMIC WatchDog is disabled in this EVM version and R87 is made DNP. No nRESET signal is asserted to Radar device.

Note

1. If user wants to disable the PMIC WD, please refer to the "*Pmic_wdgDisable*" caller function within "`mmwave_1_sdk_06_xx_xx_xx\examples\mmw_demo\mmwave_demo\source\mmwave_demo.c`" file.
-

2 Evaluation Module Overview

2.1 Introduction

The xWRL6844 mmWave radar Sensor is an integrated single chip mmWave sensor based on FMCW radar technology which operates in the 57GHz to 64GHz frequency band. The xWRL6844 is designed for low power, self-monitored, ultra-accurate radar systems in the automotive and industrial set of applications. The xWRL6844 EVM enables access to point-cloud data over XDS110 USB interface, as well as Raw ADC Data when interfaced with DCA1000 development kit. The xWRL6844EVM is supported by mmWave tools, demos and software including [MMWAVE-L-SDK](#) and TI's Code Composer Studio™ (using the on-board XDS110 emulator). The xWRL6844EVM can also interface with the MCU LaunchPad™ development kit ecosystem by mounting LaunchPad BoosterPack connectors.

2.2 Key Features

- Wide 4GHz bandwidth (57GHz to 61GHz) on board etched antennas(4TX,4RX) with high RF performance ROGERS RO3003 PCB substrate
- XDS110 based JTAG emulation with serial port for onboard 64-bit QSPI flash programming
- UART to USB Debug port for terminal access using FTDI FT4232H
- 60-pin, high-density (HD) connector for debug, SPI, I2C and LVDS with direct mating to DCA1000 development kit.
- Onboard 2 x CAN-FD and 1 x LIN PHY transceivers
- EVM supports input voltage range (5V to 12V) using DC Jack to power the board
- 5V USB Powered standalone mode of operation
- On-board INA228A Current sensors to measure per rail power consumption of the Radar device

2.3 Kit Contents

xWRL6844EVM Kit includes the following:

- xWRL6844EVM Evaluation board
- Micro USB cable
- Quick Start Guide
- Screws, spacers and nuts to allow mounting of EVM

2.4 Specification

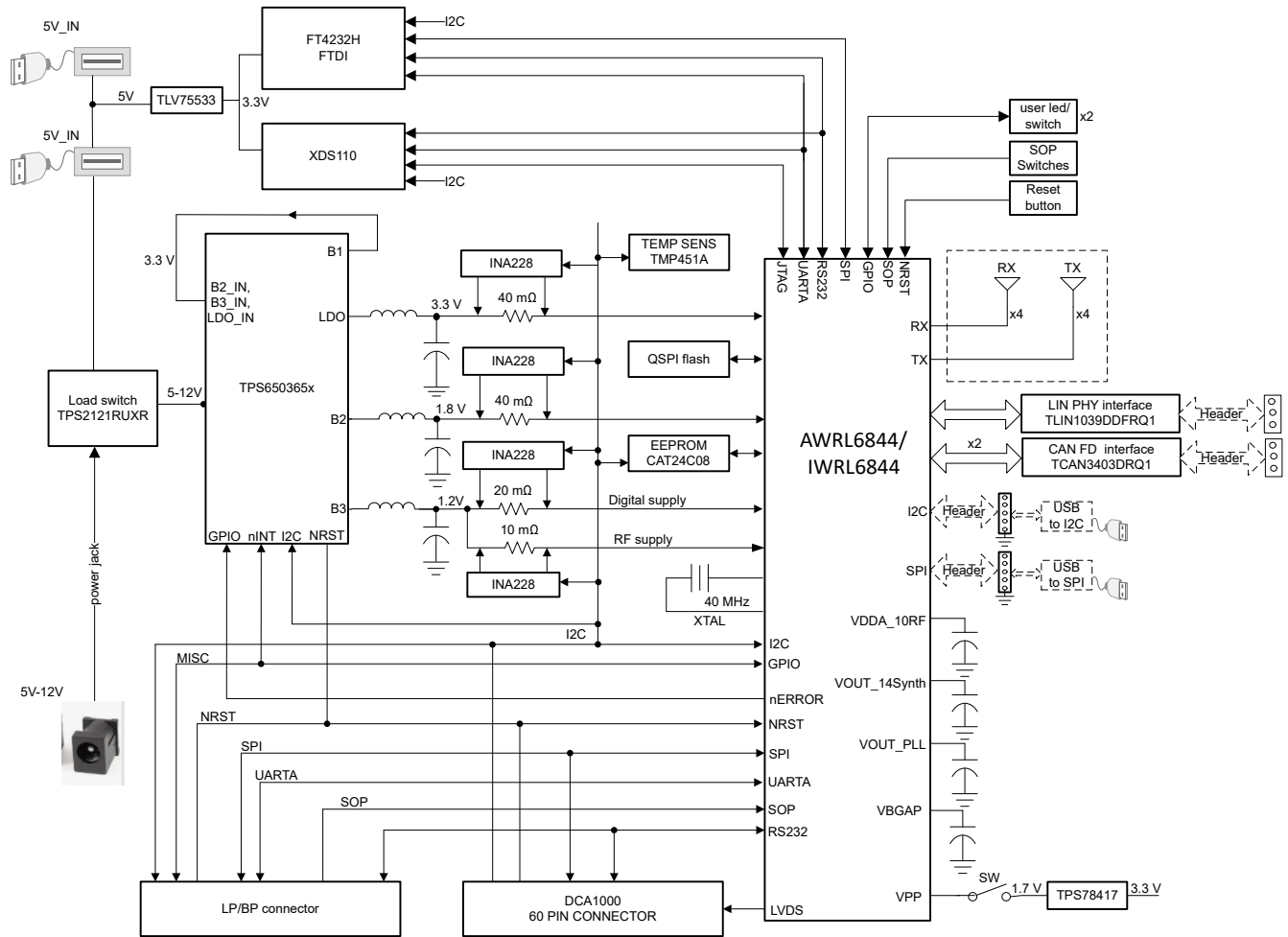

Figure 2-1. Functional Block Diagram

Figure 2-1 shows functional block diagram of xWRL6844EVM. The EVM contains all essential components for the TI mmWave radar system: PMIC, SFLASH, SOP configuration, filter for power supply, mmWave Radar Sensor, USB to UART converter and a 60-pin Samtec connector for interfacing with DCA1000. The xWRL6844EVM has a provision to mount a launch-pad booster-pack connector which can be connected to TI's LaunchPad boards.

2.5 Device Information

The documents in [Table 2-1](#) provide information regarding devices from Texas Instruments used in the assembly of xWRL6844 EVM. This user's guide is available from TI web site under literature number SWRU630. Any letter appended to literature number corresponds to the current document revision that is current at the time of the writing of this document.

Table 2-1. Related Device Documentation

Devices Used on the EVM	Data Sheet
TMP451-Q1	TMP451AQDQFRQ1
TPDE004D	TPDE004DRYR
TPS2121	TPS2121
TPS65036501	TPS650365-Q1
TLV75533PDRV	TLV755P
TPS78417QDBVRQ1	TPS784-Q1
INA228A	INA228AIDGST
TS3A5018RSVR	TS3A5018
TS3A44159PWR	TS3A44159
TS3A24157DGSR	TS3A24157
TS3A27518EPWR	TS3A27518E
TM4C1294NCPDTT3	TM4C1294NCPDT
TCAN3403DRQ1	TCAN3403-Q1
TLIN1039DDFRQ1	TLIN1039-Q1
SN74LVC1G11DSFR	SN74LVC1G11D

3 Hardware

CAUTION



Hot surface. Contact can cause burns. Do not touch.

The xWRL6844EVM includes four receivers and four transmitters with a wide field of view antenna on a High RF Performance ROGERS3003 PCB substrate.

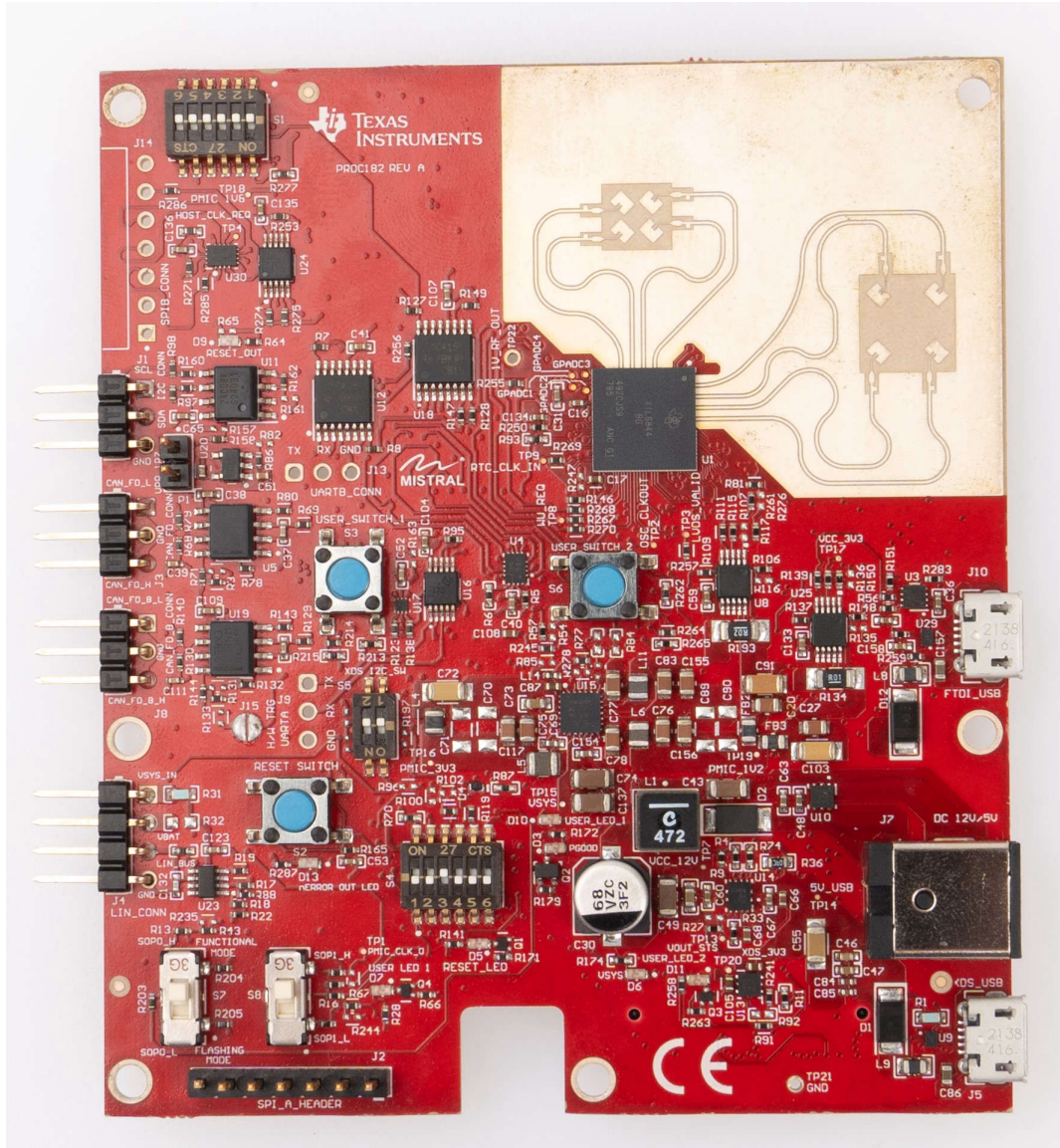

Figure 3-1. xWRL6844EVM (Top View)

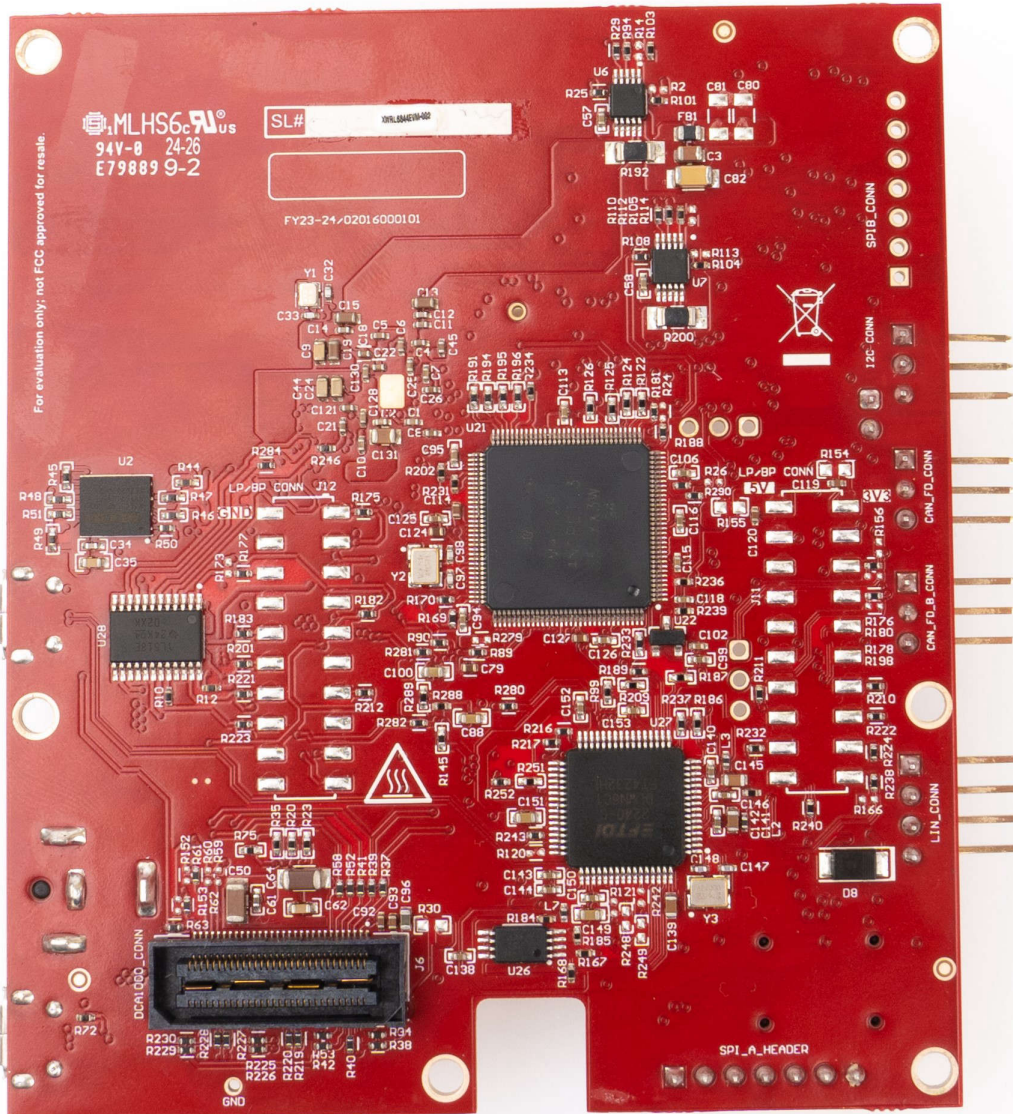

Figure 3-2. xWRL6844EVM (Bottom View)

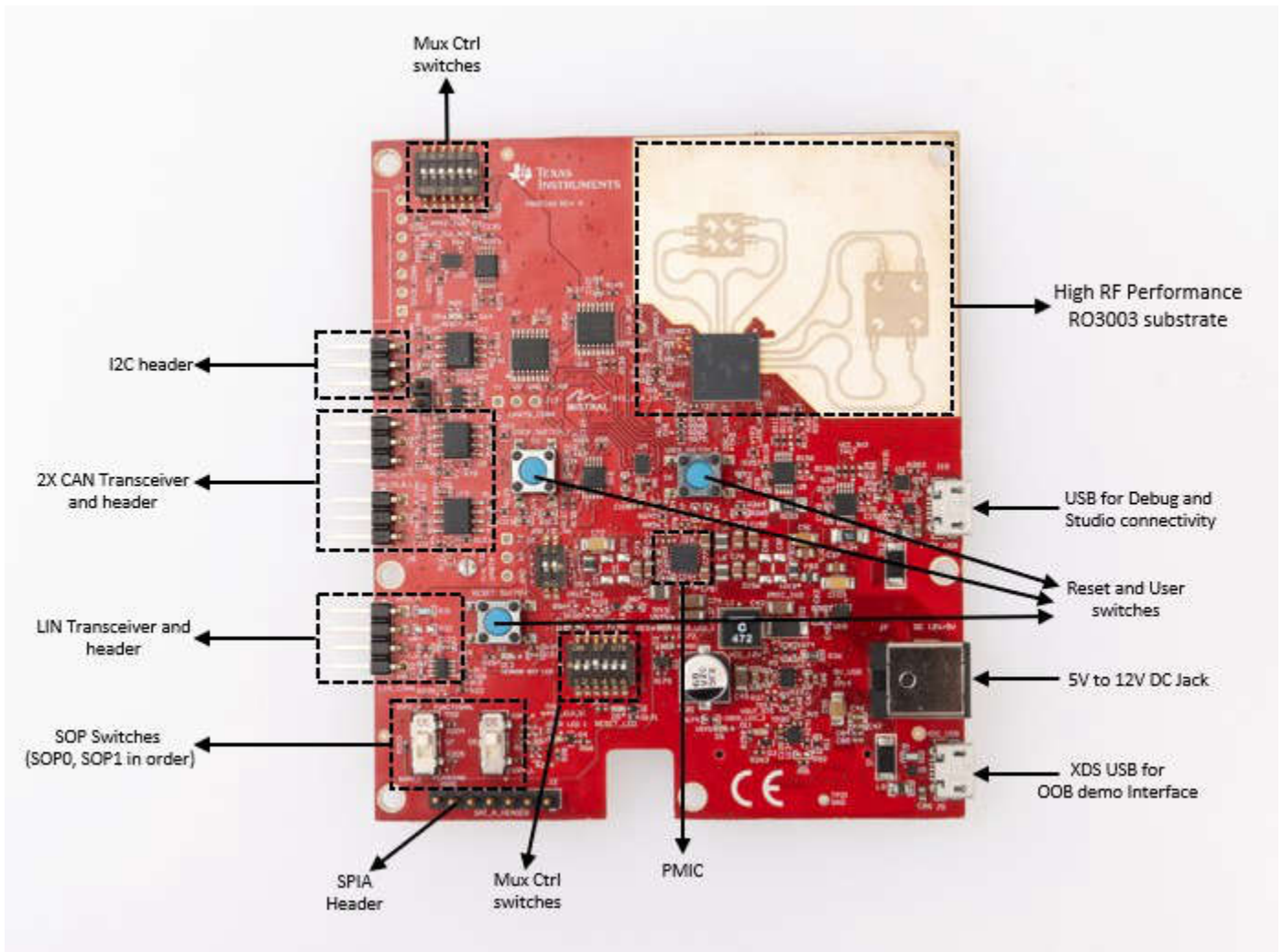

Figure 3-3. Salient Features of EVM (Top Side)

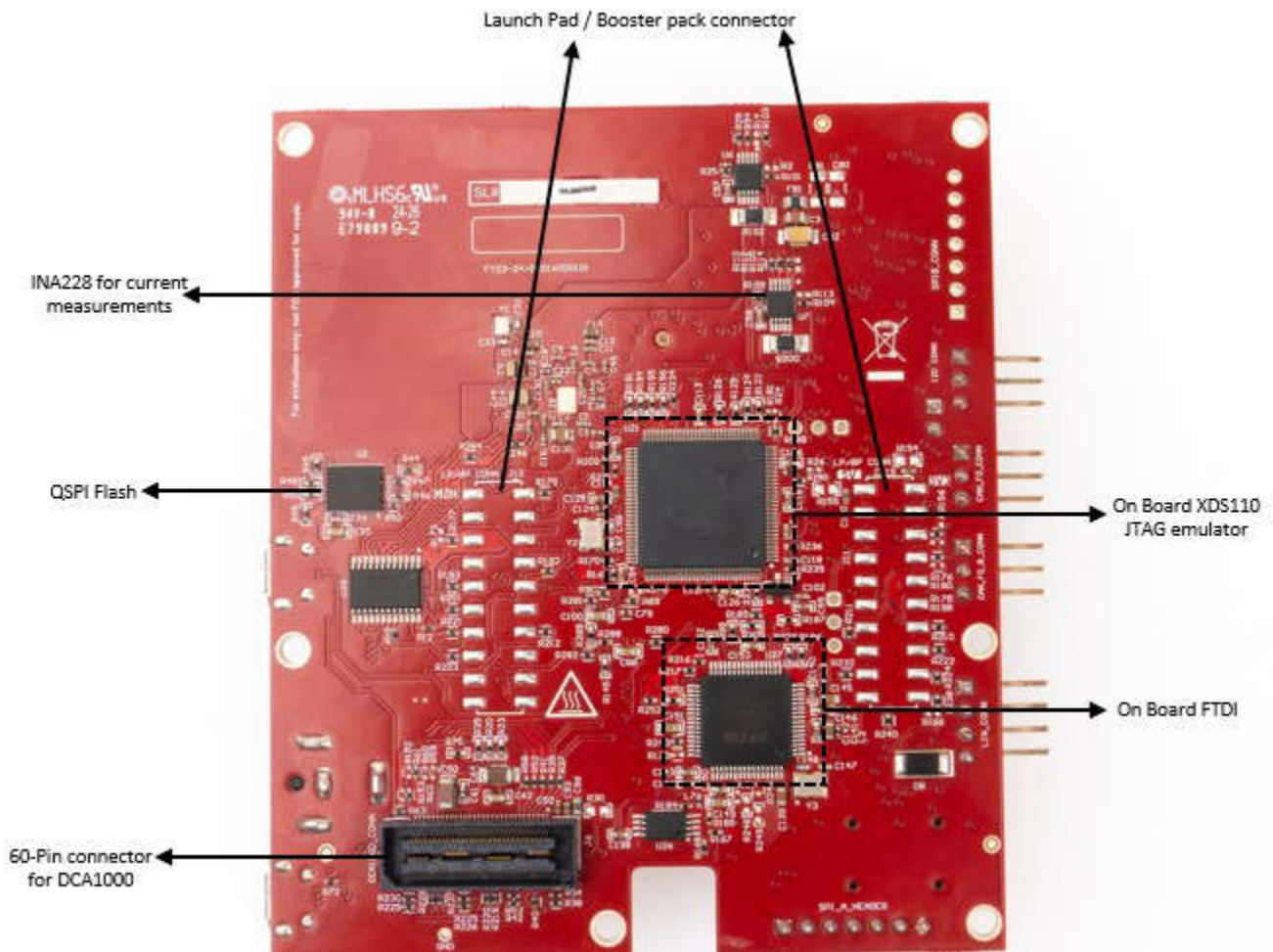

Figure 3-4. Salient Features of EVM (Bottom Side)

3.1 xWRL6844EVM Antenna

The xWRL6844EVM includes four transmitter and four receiver ROGERS RO3003 based antennas on the PCB. Figure 3-5 shows the antenna configuration.

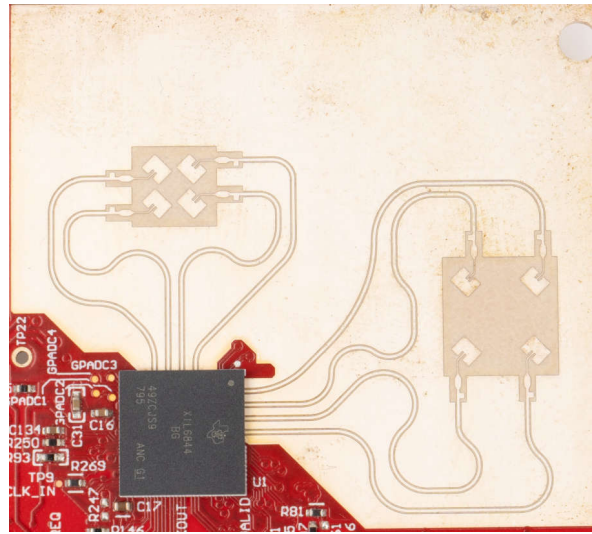



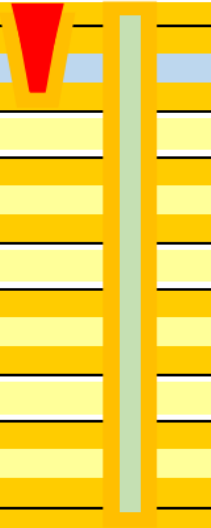

Figure 3-5. TX and Rx Antennas of the EVM

Note

The xWRL6844EVM has an antenna gain of approximately 5-6 dBi across each antenna element.

3.1.1 PCB Material

The dielectric material used for this PCB is ROGERS RO3003 of 5mil thickness with rolled copper for the Antenna and transmission lines while 370HR is used for the rest of the layers.

Type	Layer	Total Cu Thickness		Final Thickness		Construction	
		µm	mils	µm	mils		
Solder Mask				20	0,8	 IMM SILVER	
	1	40	1,6	23 17	0,9 0,7		
				127	5,0		Plating Cu (Total Cu final minimum = 34µm)
							Copper RA
	2	35	1,4	35	1,4		Core Rogers RO3003 RA
							Copper RA
				140	5,5		Prepreg 370HR
	3	35	1,4	35	1,4		Copper
				254	10,0		Core 370HR
	4	35	1,4	35	1,4		Copper
				140	5,5		Prepreg 370HR
	5	35	1,4	35	1,4		Copper
				254	10,0		Core 370HR
	6	35	1,4	35	1,4		Copper
				140	5,5		Prepreg 370HR
	7	35	1,4	35	1,4		Copper
				127	5,0		Core 370HR
	8	40	1,6	17	0,7	Copper	
				23	0,9	Plating Cu (Total Cu final minimum = 34µm)	
Solder Mask				20	0,8	 IMM SILVER	
Total Thickness :				1,512	mm		
				0,0595	(inch)	± 10%	

3.1.1.1 Transmitter and Receiver Virtual Array

The transmitter and receiver antenna positions shown in [Figure 3-6](#) form a virtual array of sixteen transmitter and receiver pairs. This allows finer object detections in both azimuth and Elevation planes with an angular resolution of 29° . Receiver antennas are spaced at distance D ($\lambda/2$) apart in both azimuth and elevation plane. The transmitter antennas are spaced at distance D (λ) apart in both azimuth and elevation plane.

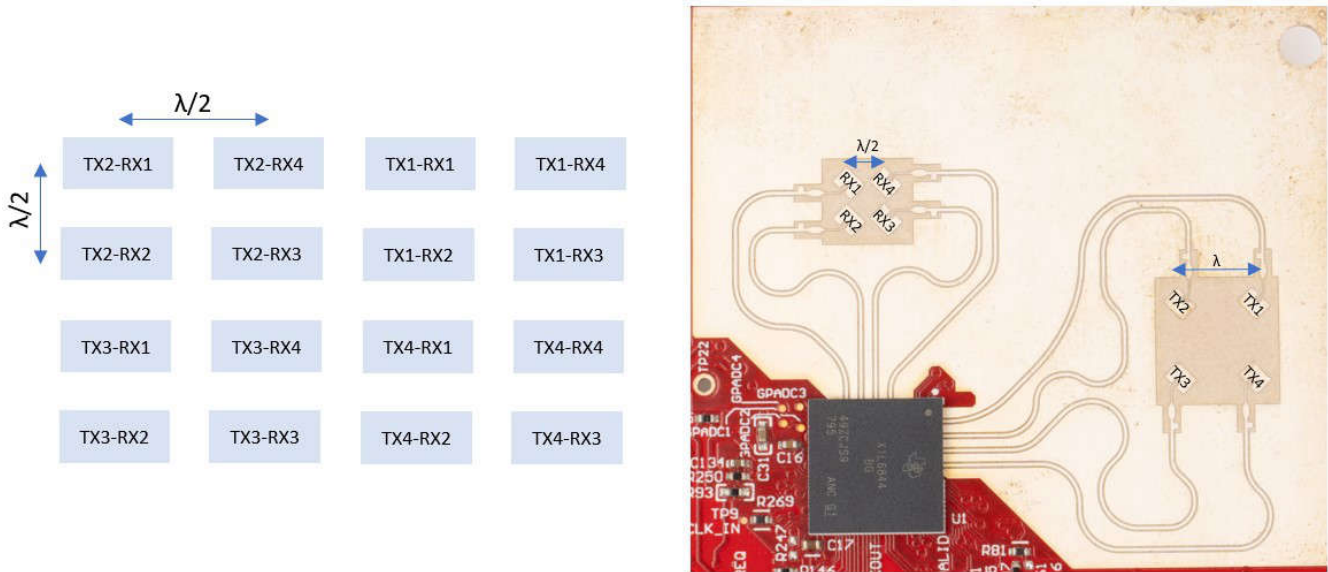

Figure 3-6. Antenna Virtual array with respect to TXs and RXs

[Figure 3-7](#) and [Figure 3-8](#) below show the antenna radiation pattern with regard to azimuth and elevation planes. Both figures show the radiation pattern for TX1, TX2, TX3, TX4 and RX1, RX2, RX3 and RX4 together. All of the measurements were done with a Tx and Rx combination together. Thus, for the -6dB beam width, the user must see a 12dB drop (6dB from Tx and 6dB from Rx)

Note

Wavelength (λ) is computed based on a frequency of 59GHz. Antenna placements were made according to this frequency.

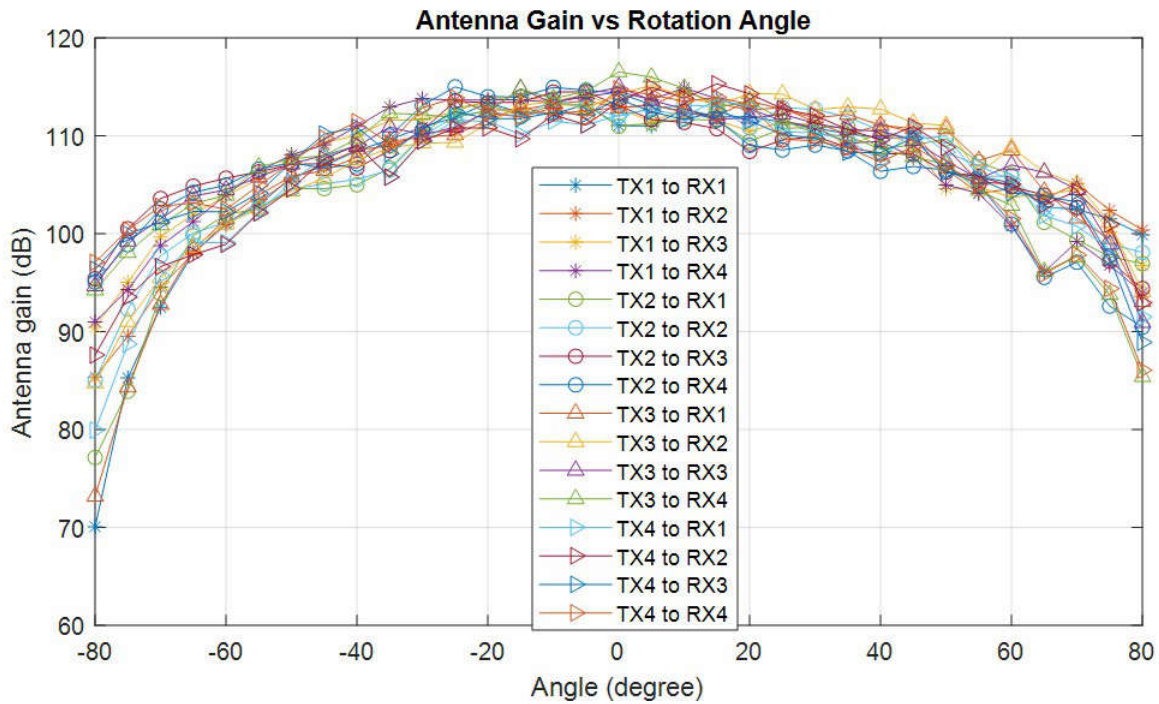

Figure 3-7. xWRL6844EVM Azimuth Antenna Radiation Pattern

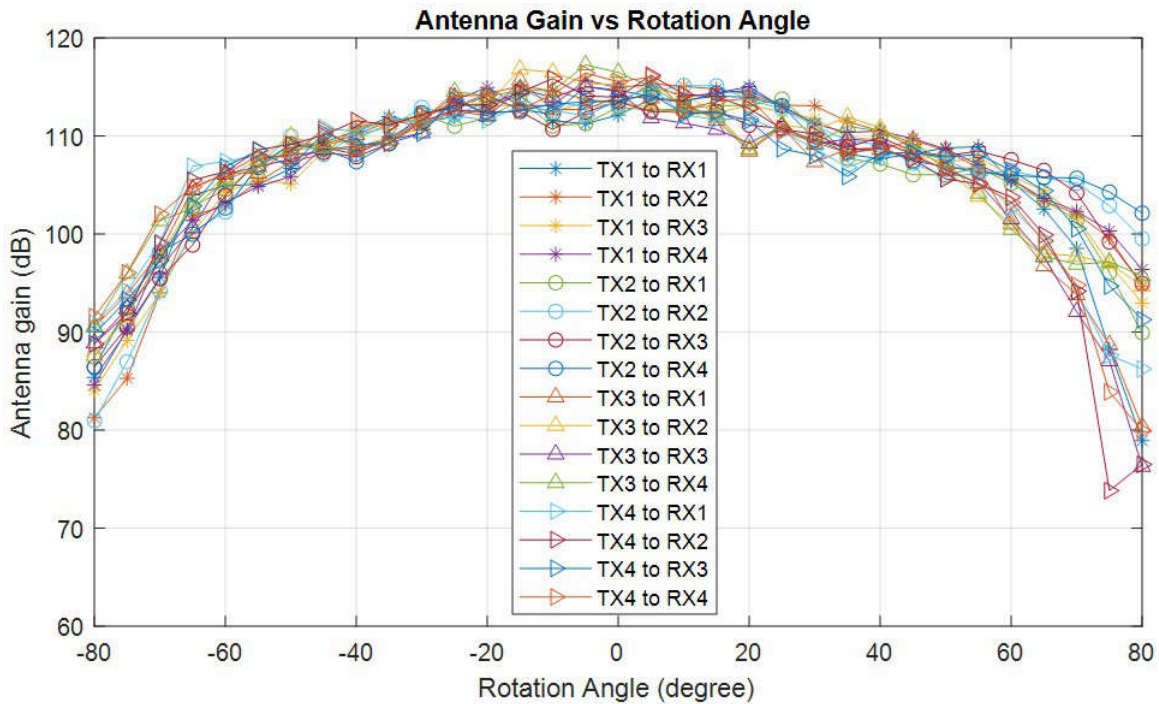

Figure 3-8. xWRL6844EVM Elevation Antenna Radiation Pattern

Note

In accordance with the EN 62311 RF exposure test, a minimum separation distance of 20 centimeters must be maintained between the user and the EVM during operation.

3.1.1.2 Phase summary of xWRL6844 Device + Antenna combined

The below table provides the summarized phase details corresponding to xWRL6844 IC and xWRL6844 Board when combined together.

1. Interior to xWRL6844 IC,
 - a. RX1/RX2 are in-phase, RX3/RX4 are in-phase. But both pairs are out of phase (by 180°)
 - b. TX1/TX4 are in-phase, TX2/RX3 are in-phase. But both pairs are out of phase (by 180°)
2. Due to antenna feed on EVM,
 - a. RX1/RX2 are in-phase, RX3/RX4 are in-phase. But both pairs are out of phase (by 180°)
 - b. TX1/TX2 are in-phase, TX3/RX4 are in-phase. But both pairs are out of phase (by 180°)
3. When IC + EVM antenna combined together,
 - a. RX1/RX2/RX3/RX4 are in-phase.
 - b. TX1/TX3 are in-phase, TX2/RX4 are in-phase. But both pairs are out of phase (by 180°)

Table 3-1.

	RX1	RX2	RX3	RX4	TX1	TX2	TX3	TX4
xWRL6844 IC	+1	+1	-1	-1	+1	-1	-1	+1
xWRL6844 EVM	+1	+1	-1	-1	+1	+1	-1	-1
Device + EVM	+1	+1	+1	+1	+1	-1	+1	-1

Note

The "*h_ChirpTxBpmEnSel*" field can be used to perform binary phase inversion. To make sure all the Virtual channels are in the same phase, user can program 180° phase shift to any of the two pairs of Tx channels. For more API level details, refer to Interface control document and TI mmWave SDK.

3.2 EVM Mux Block Diagram

Figure 3-9 shows different functionality muxing options for digital signals. The xWRL6844 contains multiple internal IPs and features. The EVM provides de-muxing options using various analog muxes and switches to improve the user experience. [Switch Settings](#) section shows different switch and mux configurations to enable connection to different peripherals.

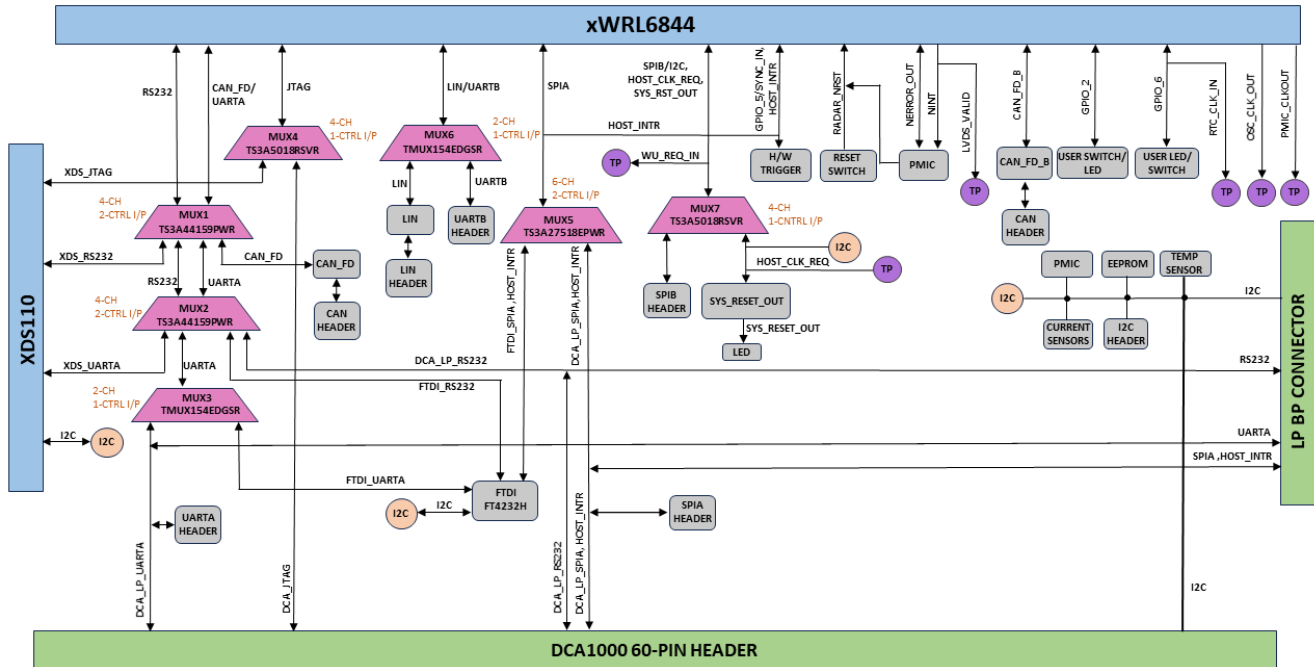

Figure 3-9. Functionality Muxing Options in the EVM

3.3 Switch Settings

The Figure 3-10 shows the part designators and positions of the switches on xWRL6844EVM for different SOP mode settings. Table 3-2 shows the different boot mode configurations for the device. xWRL6844 supports Application mode/ Functional mode, Device management mode/ QSPI flashing mode, and Debug modes. The mode (SOP) configurations shown below Table 3-2 must be exercised first. After the correct SOP mode is set, an nRESET must be issued to register the SOP setting. In the Figure 3-10 the current SOP mode shown is Debug mode.

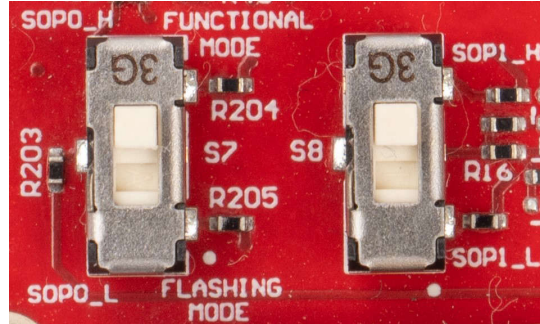

Figure 3-10. SOP switches (S7, S8)

Table 3-2. SOP settings

SOP Mode	PMIC_CLK_OUT, TDO	Combinations SOP1(S8), SOP0(S7)
SOP_MODE1	Device Management Mode/ QSPI Flashing Mode	00
SOP_MODE2	Application mode/ Functional Mode	01
SOP_MODE4	Debug Mode/ Development Mode	11

The S1 and S4 slide switches allows user connect to the digital interfaces from different peripherals

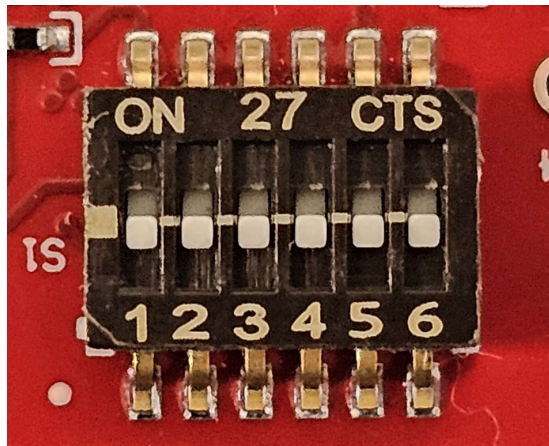

Figure 3-11. Slide Switch (S1)

Table 3-3. S1 Switch Settings

Reference Designator	Switch OFF	Switch ON
S1.1	CAN PHY B: Stand by Mode Disable	CAN PHY B: Stand by Mode Enable
S1.2	XDS_RS232	FTDI_DCA_LP/BP_RS232
S1.3	FTDI_RS232	DCA_LP/BP_RS232
S1.4	CAN_FD_A	XDS_DCA_LP/BP_FTDI_UARTA
S1.5	DCA_LP/BP_FTDI_UARTA	XDS_UARTA
S1.6	FTDI_UARTA	DCA_LP/BP_UARTA

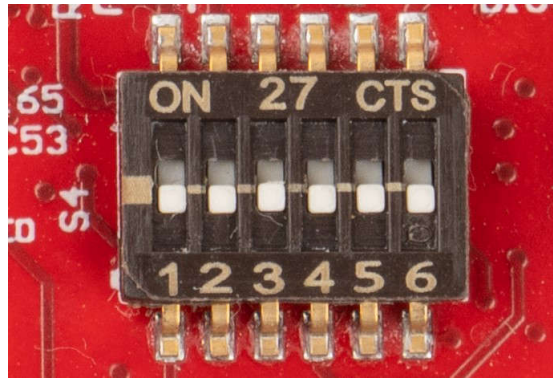

Figure 3-12. Slide Switch (S4)



Table 3-4. S4 Switch Settings

Reference Designator	Switch OFF	Switch ON
S4.1	CAN PHY A: Stand by Mode Disable	CAN PHY A: Stand by Mode Enable
S4.2	LIN PHY: Enable	LIN PHY: Disable
S4.3	FTDI_SPI	DCA_SPI
S4.4	XDS_JTAG	DCA_JTAG
S4.5	UARTB	LIN
S4.6	SPIB	I2C/HOST_CLK_REQ/SYS_RST_OUT

3.4 Push Button Switches

Table 3-5 contains list of Push Button Switches on the xWRL6844EVM. The User switches are connected to GPIO and can be used for quick integration of a simple interface



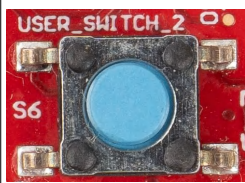
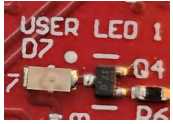



Table 3-5. List of Push Button Switches

Switch reference designators	Usage	Comments	Image
S2	Reset Switch	This Switch can be used to reset the xWRL6844 device	
S3	User Switch 1	When pushed, GPIO_2 logic is pulled high	
S6	User Switch 2	When pushed, GPIO_6 logic is pulled high	

3.5 LEDs

Table 3-6 contains list of LEDs present on the xWRL6844EVM. The User LEDs are provided for integration and can be controlled using the GPIO's of xWRL6844.

Table 3-6. List of LEDs

LED reference designators	Usage	Comments	Image
D3	PGOOD LED	Glow once all the power supplies are stable from PMIC	
D6	Power ON LED	5V or 12V Power indication	
D5	Reset LED	This LED Indicates the state of Reset pin on xWRL6844 device. LED glowing indicates the device is out of reset.	
D7	User LED: Customer programmable	Glow when GPIO_2 is logic-1	
D9	SYS_RST_OUT LED	Glow in presence of any System reset from xWRL6844 device	
D10	FTDI suspend LED	Glow when FTDI is in suspend state	
D11	User LED: Customer programmable	Glow when GPIO_6 is logic-1	
D13	nERROR LED	Glow in presence of any HW error in xWRL6844 device	

3.6 DC Input Jack

The xWRL6844EVM can be powered-up using the 5V to 12V DC Jack. When DC Jack is connected, the Priority switchover is given to DC-jack's Voltage at the power mux(TPS2121).

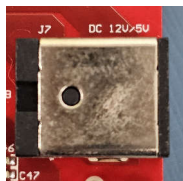

Note

After the 5V-12V power supply is provided to the EVM, TI recommends pressing the NRST switch one time to verify for a reliable boot-up state.

Note

All digital IO pins of the device (except NRESET) are not fail safe. Therefore, care needs to be taken that the digital IO pins are not driven externally without the VIO supply being present to the device.

3.7 USB Connector

The xWRL6844EVM has two micro USB connectors. These connectors are for xds110 and FTDI interface connectivity. These connectors can also be used to provide 5V power supply input to the EVM.

FTDI Interface: Micro USB Connector J10 provides access to the xWL6844 device's UART-A, SPI, I2C, RS232/ UART-B, SOP and Reset signals



Figure 3-13. FTDI USB (J10)

XDS Interface:Micro USB connector J5 provides access to the xWL6844 device's I2C, JTAG, UART_A, RS232/ UART-B signals. This is the UART interface used to flash the binary to the onboard serial flash and for running Out-of-box (OOB) demo.



Figure 3-14. XDS USB (J5)

3.8 DCA1000 HD Connector

The 60-pin HD connector shown in [Figure 3-15](#) provides access to the xWRL6844 device's high-speed data and controls signals (I2C, LVDS, NRST, RS232/UART-B, SPI, UART-A) through the DCA1000.

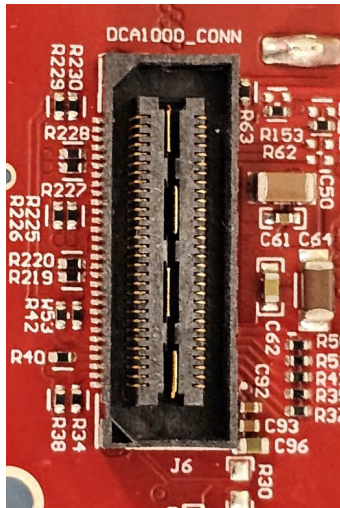

Figure 3-15. DCA1000 HD Connector

The [Figure 3-16](#) further details on the xWRL6844 device's signals being brought out at the DCA1000 direct mating connector.

60-PIN HD CONNECTOR FOR DCA1000

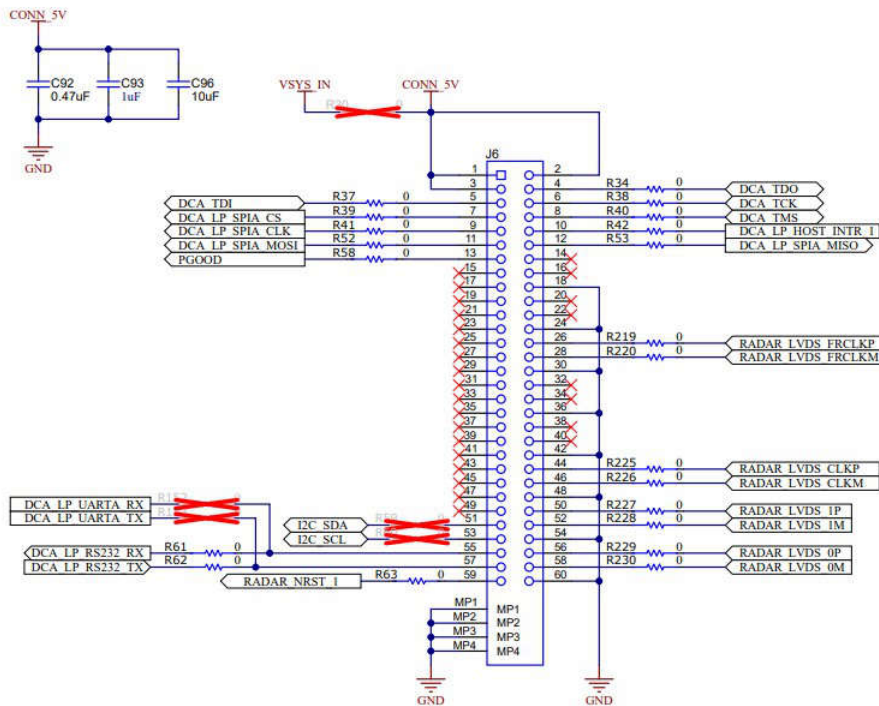

Figure 3-16. DCA1000 HD Connector Pins

3.9 BoosterPack Connector for LaunchPad Connectivity

J11/J12 are the booster pack connectors provided on the EVM. The user can populate the LP-BP connector to connect with other TI launchpad kits.

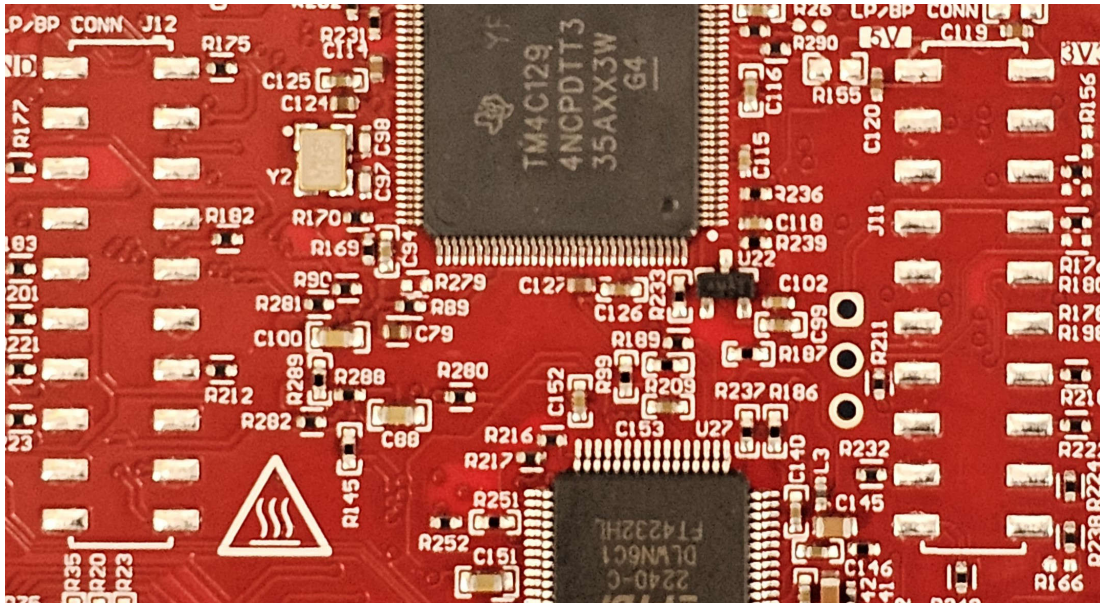

Figure 3-17. Booster Pack Connector

The Figure 3-18 shows the various signals that have been brought-out on the LP-BP connector.

LP/BP CONNECTOR

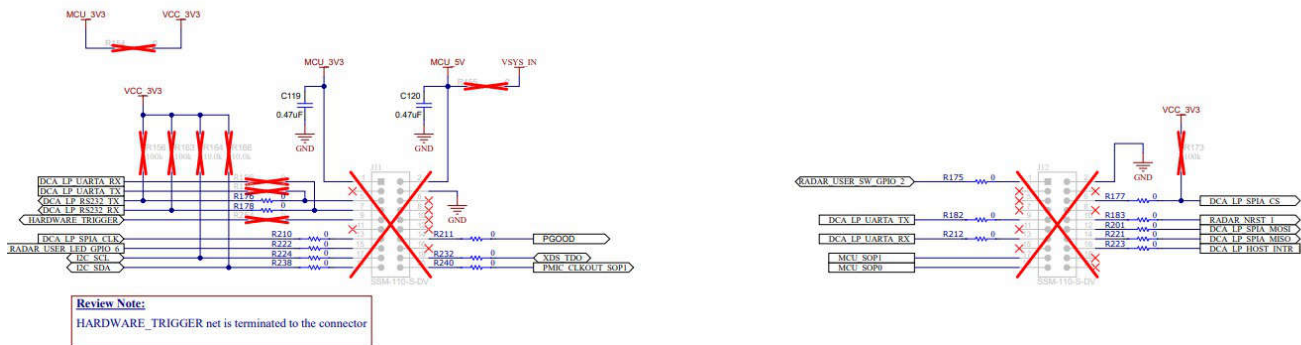

Figure 3-18. LP-BP connector Pins

3.10 CAN-FD_B Connector

The CAN connector provides access to the CAN_FD_B interface (CAN_L and CAN_H signals) from the onboard CAN-FD transceiver. These signals can be directly wired to the CAN bus.

The J8 connector shown in [Figure 3-19](#) provides the CAN_L and CAN_H signals from the onboard CAN-FD transceiver (TCAN3403DRQ1). CAN standby input can be controlled by toggling S1.1 switch

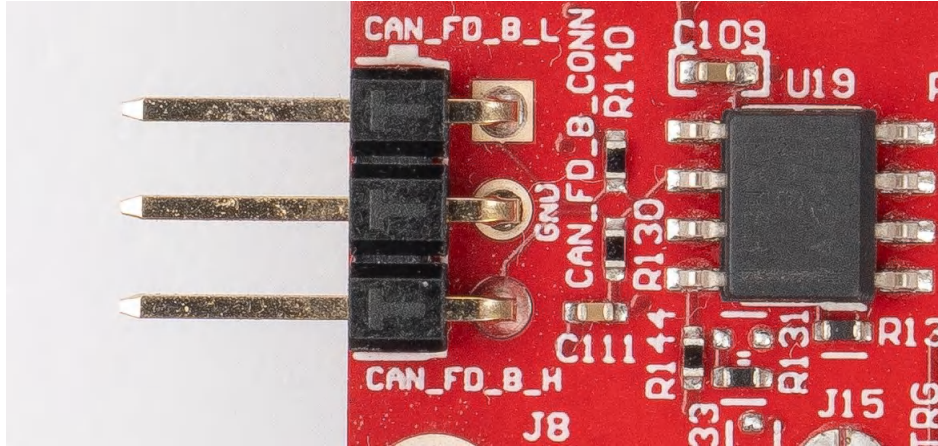

Figure 3-19. CAN-FD B Connector

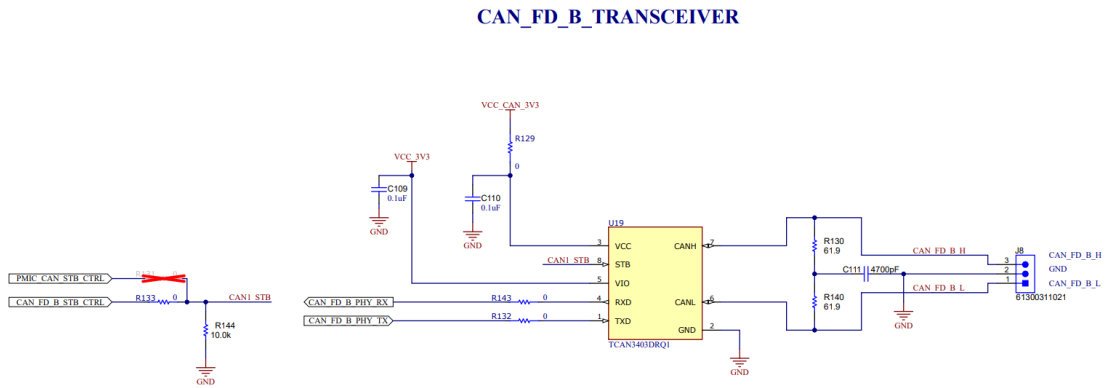

Figure 3-20. CAN-FD PHY Used in the EVM

3.11 CAN-FD_A Connector

The J3 connector shown in [Figure 3-21](#) provides the CAN_L and CAN_H signals from the onboard CAN-FD transceiver (TCAN3403DRQ1). These signals are wired to the CAN bus after muxing with the UART-A signals; one of the two paths must be selected. CAN signal paths get connected to PHY by changing the switch S1.4 to off position. CAN standby input can be controlled by toggling S4.1 switch.

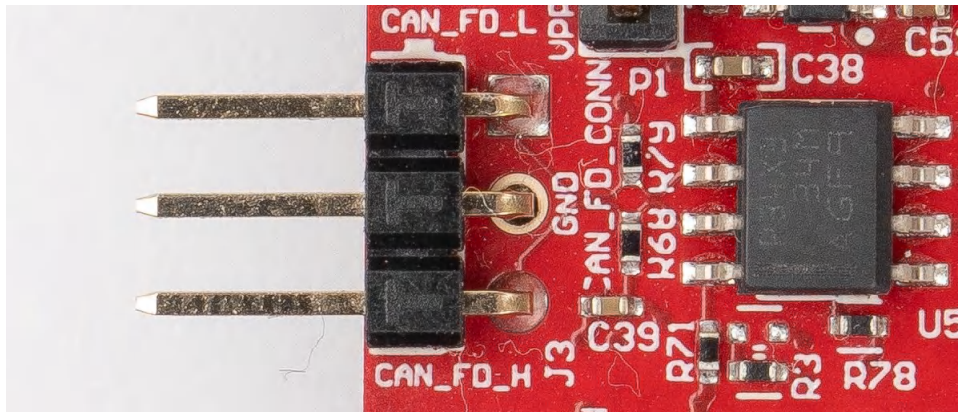

Figure 3-21. CAN-FD A Connector

ANALOG MUX -XDS /FTDI, DCA RS232, CAN_FD / UART A

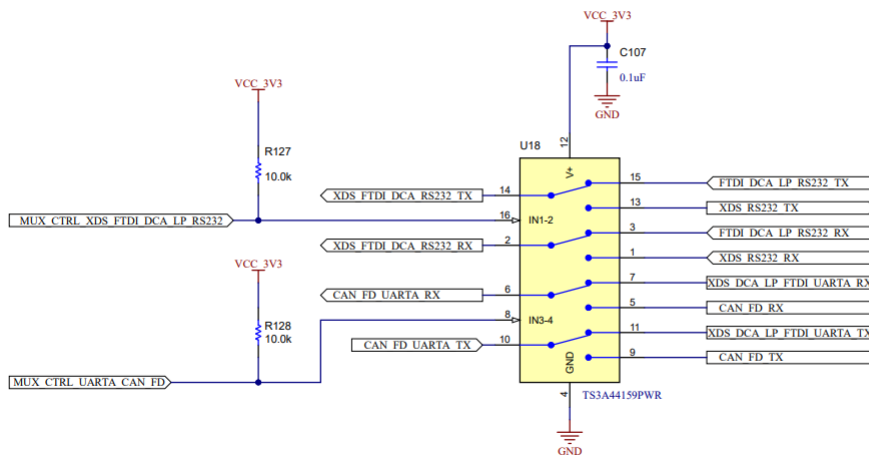

Figure 3-22. Analog Mux for the CAN PHY Switch

CAN_FD_TRANSCEIVER

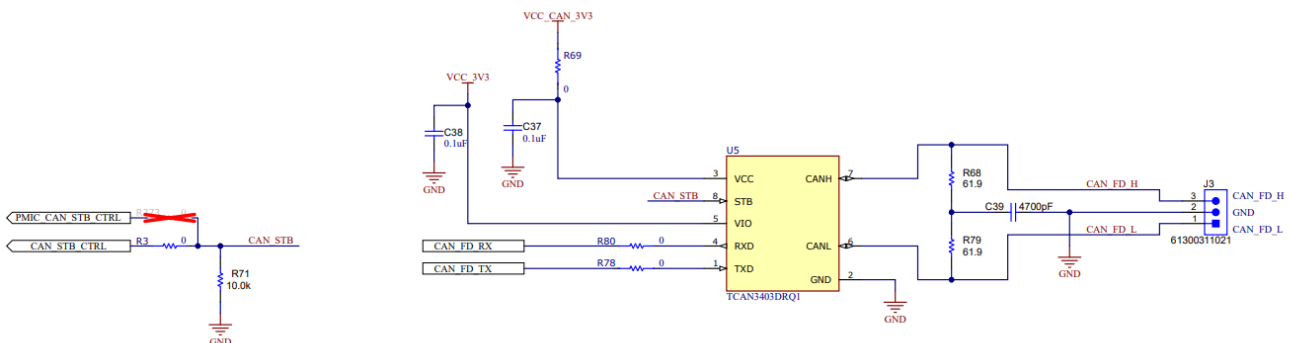

Figure 3-23. CAN-FD PHY Used in the EVM

3.12 LIN-PHY Connector

Figure 3-24 shows the LIN PHY (TLIN1039DDFRQ1) interface to the device. LIN PHY can operate with a different supply voltage than the mmWave sensor, an external VBAT option is provided for the LIN VDD supply, by default VSYS_IN supply is provided for J4 connector.

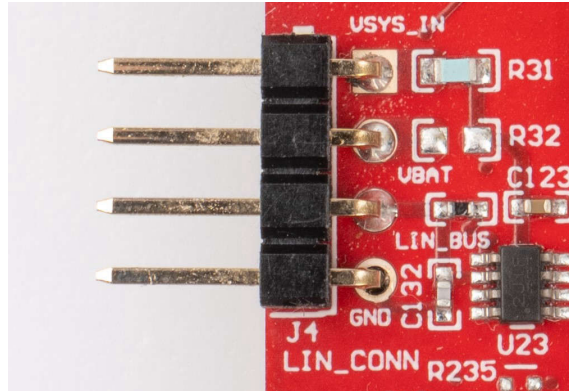

Figure 3-24. LIN Connector

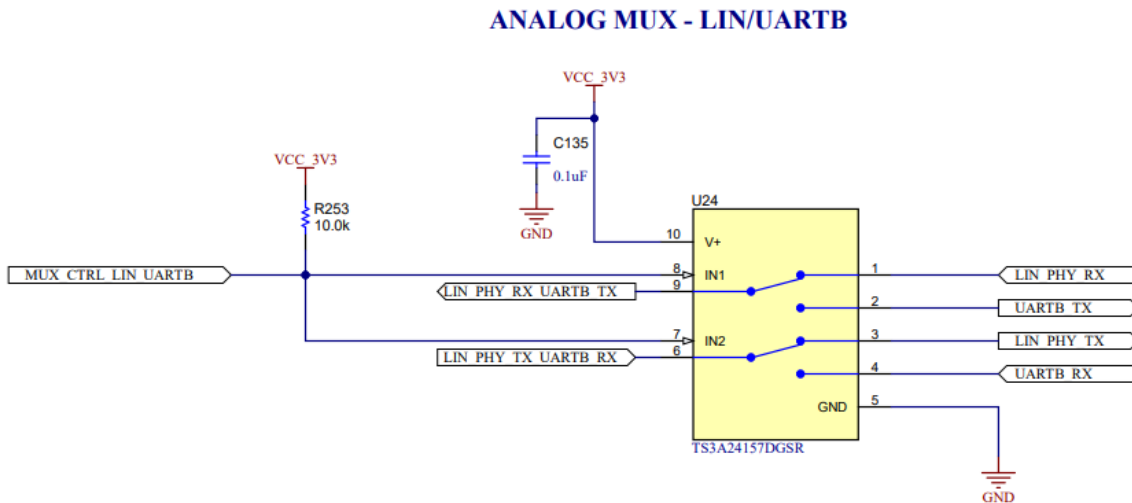

Figure 3-25. Analog Mux for the LIN PHY Switch

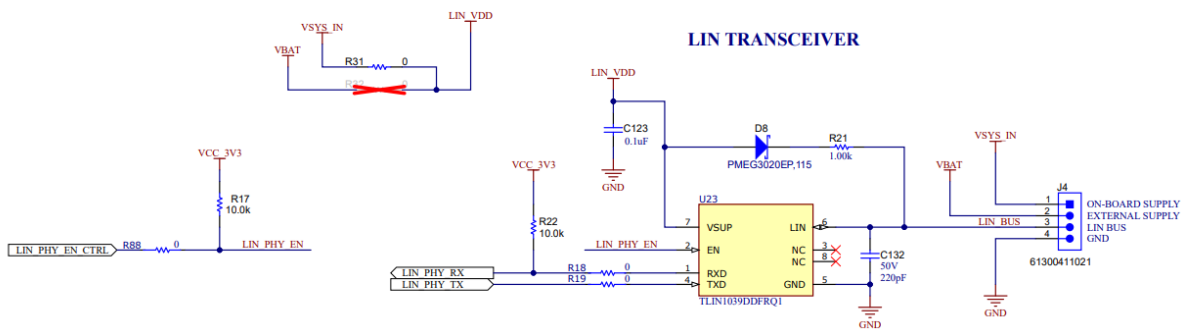

Figure 3-26. LIN PHY Interface

To enable the external VBAT supply, resistor R32 needs to be mounted and resistor R31 needs to be removed.

3.13 I2C Connections

The xWRL6844EVM board features a temperature sensor for measuring on-board temperature, current sensors for current measurement on 3.3V, 1.8V, 1.2VDigital, 1.2VRF power supply rails for xWRL6844 device and EEPROM for storing board ID. These are connected to TPS65036501 and xWRL6844 through I2C bus. In addition to this, header J1 is also provided for easy interface to I2C bus. Please refer to xWRL6844EVM's schematics for the I2C addresses.

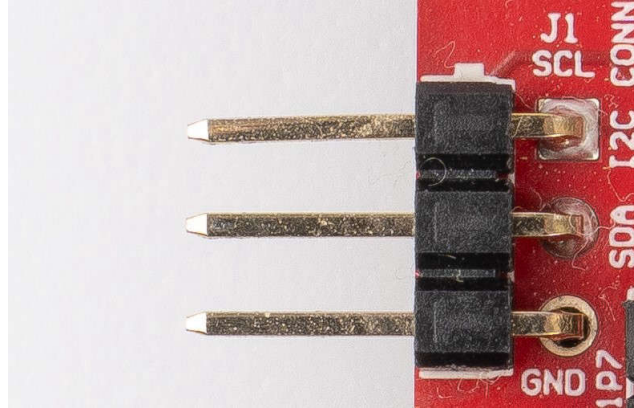

Figure 3-27. I2C Connector

3.13.1 EEPROM

The board features an EEPROM for storing the board specific IDs (for the identification of the EVM through the XDS110 interface).

3.14 XDS110 Interface

J5 connector provides access to the onboard XDS110 (TM4C1294NCPDT) emulator. This connection provides the following interfaces to the PC:

- JTAG for CCS connectivity
- Application/user UART (Configuration and data communication to PC)

When used in standalone mode of operation, the power is supplied through a single USB connector. Connector J5 is also used for configuration and data transfer through the user UART mounted on PC by XDS110 interface. When enumerated correctly, the two UART ports from the XDS110 are displayed on the device manager as a virtual COM Port, similar to that shown in [Figure 3-28](#).

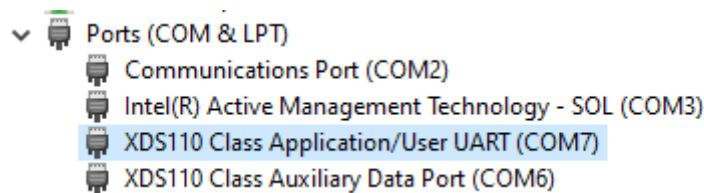

Figure 3-28. Virtual COM Port

If the PC is unable to recognize the above COM ports, install the latest [EMUpack](#).

3.15 FTDI Interface

J10 connector provides access to the onboard FTDI ports. This provides the following Interfaces to PC:

- FTDI Port A : SPI
- FTDI Port B : I2C, HOST_INTERRUPT
- FTDI Port C : UARTA, nRESET
- FTDI Port D : RS232, SOP control

When xWRL6844EVM's FTDI USB is connected for the first time to PC, Windows® may not be able to recognize the device. This is indicated and confirmed in the device manager with yellow exclamation marks, as shown in [Figure 3-29](#).

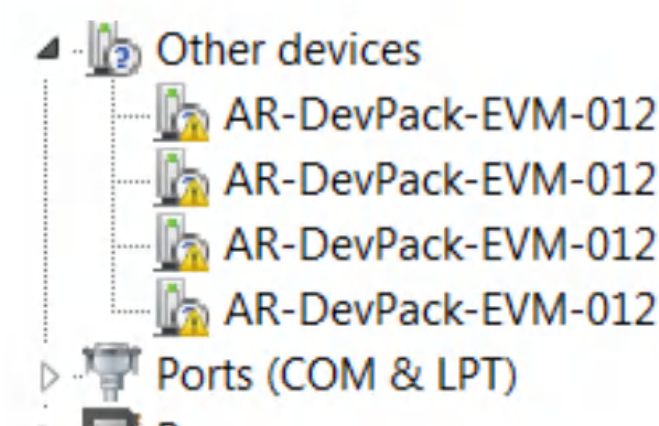

Figure 3-29. Uninstalled FTDI Drivers

In order to correctly detect these ports on the PC please download and install the latest FTDI drivers available in the (C:\ti\mmwave_sdk_tools\ftdi). This must be done for all four COM ports. When all four COM ports are installed, the device manager recognizes these devices and indicates the COM port numbers, as shown in [Figure 3-30](#).

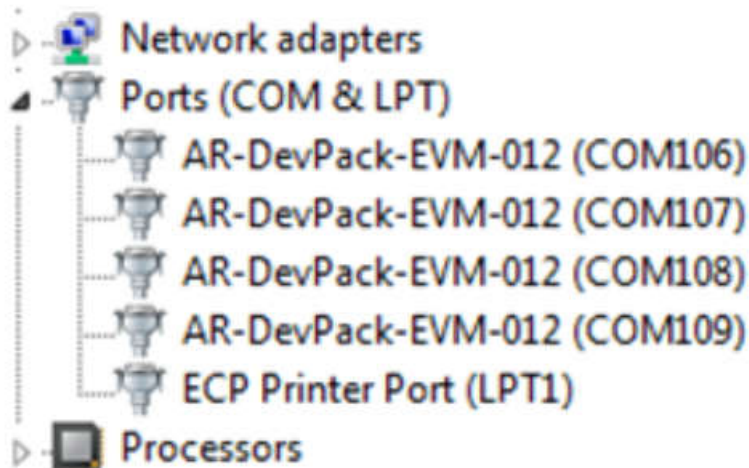

Figure 3-30. Installed FTDI Drivers

3.16 DCA1000EVM Mode

The setup for raw data capture using DCA1000EVM is shown in [Figure 3-31](#). For more details on raw ADC data capture, refer to **DCA1000 mmWave Studio xWRL6844** section in the following path of Tirex page (mmWave radar sensors/ Embedded software/ Radar Toolbox/ Hardware Docs/ DCA1000 Perdevice/ DCA1000 mmWave Studio xWRL6844 .

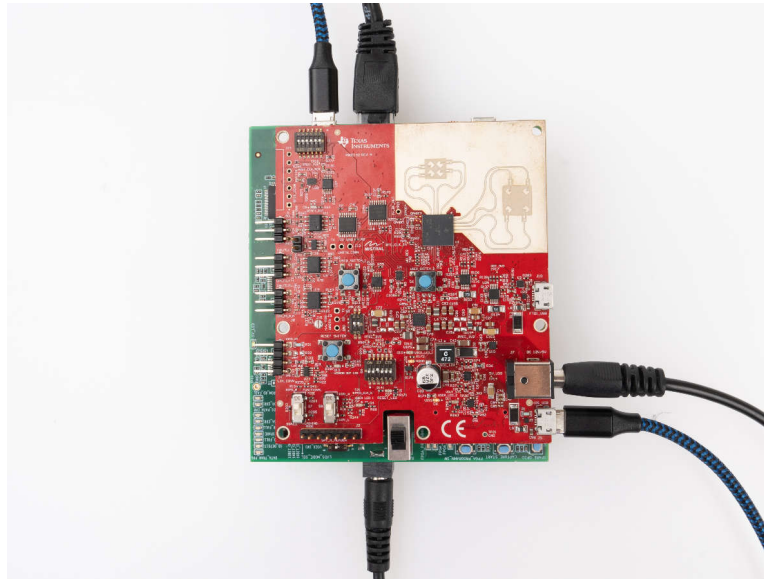

Figure 3-31. AWRL6844EVM for Raw Data Capture

The DCA Switch settings which needs to be followed for Raw Data capture are shown in [Figure 3-32](#).

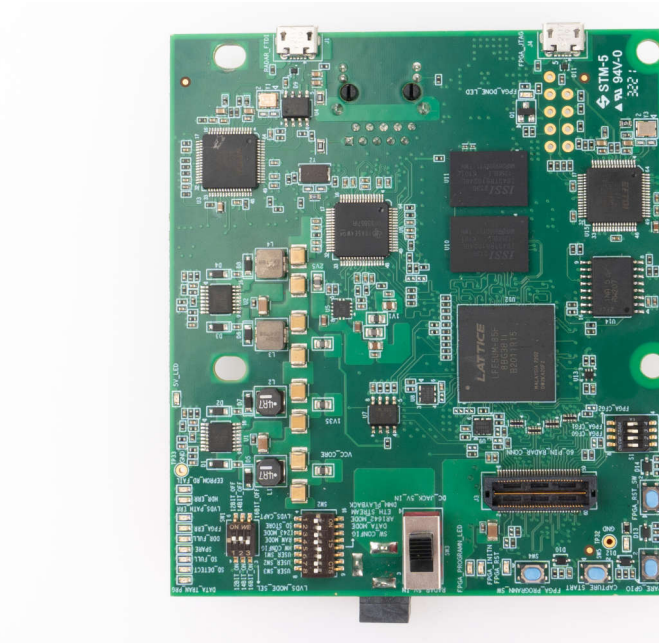

Figure 3-32. DCA1000 switch settings

Note

When EVM is directly mated with DCA1000 board, kindly use spacers which are included in the kit and ensure no physical contact happens between DCA1000 and the xWRL6844EVM as it can damage the boards.

3.17 PCB Storage and Handling Recommendations:

This EVM contains components that can potentially be damaged by electrostatic discharge. Always transport and store the EVM in the supplied ESD bag when not in use. Handle using an antistatic wristband and operate on an antistatic work surface. For more information on proper handling, refer to [SSYA010](#).

3.17.1 PCB Storage and Handling Recommendations

The immersion silver finish of the PCB provides a better high-frequency performance, but is also prone to oxidation in open environment. This oxidation causes the surface around the antenna region to blacken, however mmWave Radar performance remains intact. To avoid oxidation, the PCB must be stored in an ESD cover and kept at a controlled room temperature with low humidity conditions. All ESD precautions must be taken while using and handling the EVM.

3.17.2 Higher Power Demanding Applications

Most of the EVM can be operated with a single 5V USB cable. For higher power consumption applications where a single 5V USB supply cannot provide the power needed, use an external 5V or 12V power adapter.

4 Software, Development Tools, and Example Code

To enable quick development of end applications on the ARM Cortex-R5F core in xWRL6844, TI provides a [MMWAVE-L-SDK-6](#) that includes demo codes, software drivers, emulation packages for debug, and more. For more information, please refer to [MMWAVE-L-SDK-6](#) user's guide and getting started guide [SWRU636](#).

5 Hardware Design Files

5.1 Schematics, PCB Layout and Bill of Materials (BOM)

xWRL6844EVM Schematic, Assembly, Bill of Materials can be found on [SWRC394](#).

5.2 EVM Design Database

xWRL6844EVM Design Database containing Altium Project Source files can be found on [SWRR198](#).

5.3 Hardware Design Checklist

xWRL6844 Hardware Design Checklist containing schematic, layout recommendations can be found on [SPRADL0](#).

6 Additional Information

6.1 Trademarks

- ARM® and Cortex® are registered trademarks of Arm Limited.
- Code Composer Studio™ and LaunchPad™ are trademarks of Texas Instruments.
- Windows® is a registered trademark of Microsoft.

All trademarks are the property of their respective owners.

7 References

1. [DCA1000EVM Data Capture Card User's Guide](#)
2. [MMWAVE-L-SDK](#)
3. [Code Composer Studio](#)

7.1 TI E2E Community

Search the forums at e2e.ti.com. If you cannot find the answer, then post the question to the community.

8 Revision History

NOTE: Page numbers for previous revisions may differ from page numbers in the current version.

Changes from Revision A (November 2025) to Revision B (January 2026) Page

- | | |
|---------------------------------------------|----|
| • Removed PMIC Software implementation..... | 28 |
|---------------------------------------------|----|

Changes from Revision * (December 2024) to Revision A (November 2025) Page

- | | |
|-----------------------------------------------------------------------------------------------------------------------|----|
| • Updated description for Raw ADC Data capture..... | 1 |
| • Added EVM Revision history..... | 2 |
| • Updated description about transmitter antennas placement in <i>Transmitter and Receiver Virtual Array</i> section.. | 11 |
| • Added phase details of xWRL6844IC and EVM | 13 |
| • Updated description in <i>EVM Mux Block Diagram</i> section..... | 14 |

STANDARD TERMS FOR EVALUATION MODULES

1. *Delivery:* TI delivers TI evaluation boards, kits, or modules, including any accompanying demonstration software, components, and/or documentation which may be provided together or separately (collectively, an "EVM" or "EVMs") to the User ("User") in accordance with the terms set forth herein. User's acceptance of the EVM is expressly subject to the following terms.
 - 1.1 EVMs are intended solely for product or software developers for use in a research and development setting to facilitate feasibility evaluation, experimentation, or scientific analysis of TI semiconductors products. EVMs have no direct function and are not finished products. EVMs shall not be directly or indirectly assembled as a part or subassembly in any finished product. For clarification, any software or software tools provided with the EVM ("Software") shall not be subject to the terms and conditions set forth herein but rather shall be subject to the applicable terms that accompany such Software
 - 1.2 EVMs are not intended for consumer or household use. EVMs may not be sold, sublicensed, leased, rented, loaned, assigned, or otherwise distributed for commercial purposes by Users, in whole or in part, or used in any finished product or production system.
2. *Limited Warranty and Related Remedies/Disclaimers:*
 - 2.1 These terms do not apply to Software. The warranty, if any, for Software is covered in the applicable Software License Agreement.
 - 2.2 TI warrants that the TI EVM will conform to TI's published specifications for ninety (90) days after the date TI delivers such EVM to User. Notwithstanding the foregoing, TI shall not be liable for a nonconforming EVM if (a) the nonconformity was caused by neglect, misuse or mistreatment by an entity other than TI, including improper installation or testing, or for any EVMs that have been altered or modified in any way by an entity other than TI, (b) the nonconformity resulted from User's design, specifications or instructions for such EVMs or improper system design, or (c) User has not paid on time. Testing and other quality control techniques are used to the extent TI deems necessary. TI does not test all parameters of each EVM. User's claims against TI under this Section 2 are void if User fails to notify TI of any apparent defects in the EVMs within ten (10) business days after delivery, or of any hidden defects with ten (10) business days after the defect has been detected.
 - 2.3 TI's sole liability shall be at its option to repair or replace EVMs that fail to conform to the warranty set forth above, or credit User's account for such EVM. TI's liability under this warranty shall be limited to EVMs that are returned during the warranty period to the address designated by TI and that are determined by TI not to conform to such warranty. If TI elects to repair or replace such EVM, TI shall have a reasonable time to repair such EVM or provide replacements. Repaired EVMs shall be warranted for the remainder of the original warranty period. Replaced EVMs shall be warranted for a new full ninety (90) day warranty period.

WARNING

Evaluation Kits are intended solely for use by technically qualified, professional electronics experts who are familiar with the dangers and application risks associated with handling electrical mechanical components, systems, and subsystems.

User shall operate the Evaluation Kit within TI's recommended guidelines and any applicable legal or environmental requirements as well as reasonable and customary safeguards. Failure to set up and/or operate the Evaluation Kit within TI's recommended guidelines may result in personal injury or death or property damage. Proper set up entails following TI's instructions for electrical ratings of interface circuits such as input, output and electrical loads.

NOTE:

EXPOSURE TO ELECTROSTATIC DISCHARGE (ESD) MAY CAUSE DEGRADATION OR FAILURE OF THE EVALUATION KIT; TI RECOMMENDS STORAGE OF THE EVALUATION KIT IN A PROTECTIVE ESD BAG.

3 Regulatory Notices:

3.1 United States

3.1.1 Notice applicable to EVMs not FCC-Approved:

FCC NOTICE: This kit is designed to allow product developers to evaluate electronic components, circuitry, or software associated with the kit to determine whether to incorporate such items in a finished product and software developers to write software applications for use with the end product. This kit is not a finished product and when assembled may not be resold or otherwise marketed unless all required FCC equipment authorizations are first obtained. Operation is subject to the condition that this product not cause harmful interference to licensed radio stations and that this product accept harmful interference. Unless the assembled kit is designed to operate under part 15, part 18 or part 95 of this chapter, the operator of the kit must operate under the authority of an FCC license holder or must secure an experimental authorization under part 5 of this chapter.

3.1.2 For EVMs annotated as FCC – FEDERAL COMMUNICATIONS COMMISSION Part 15 Compliant:

CAUTION

This device complies with part 15 of the FCC Rules. Operation is subject to the following two conditions: (1) This device may not cause harmful interference, and (2) this device must accept any interference received, including interference that may cause undesired operation.

Changes or modifications not expressly approved by the party responsible for compliance could void the user's authority to operate the equipment.

FCC Interference Statement for Class A EVM devices

NOTE: This equipment has been tested and found to comply with the limits for a Class A digital device, pursuant to part 15 of the FCC Rules. These limits are designed to provide reasonable protection against harmful interference when the equipment is operated in a commercial environment. This equipment generates, uses, and can radiate radio frequency energy and, if not installed and used in accordance with the instruction manual, may cause harmful interference to radio communications. Operation of this equipment in a residential area is likely to cause harmful interference in which case the user will be required to correct the interference at his own expense.

FCC Interference Statement for Class B EVM devices

NOTE: This equipment has been tested and found to comply with the limits for a Class B digital device, pursuant to part 15 of the FCC Rules. These limits are designed to provide reasonable protection against harmful interference in a residential installation. This equipment generates, uses and can radiate radio frequency energy and, if not installed and used in accordance with the instructions, may cause harmful interference to radio communications. However, there is no guarantee that interference will not occur in a particular installation. If this equipment does cause harmful interference to radio or television reception, which can be determined by turning the equipment off and on, the user is encouraged to try to correct the interference by one or more of the following measures:

- Reorient or relocate the receiving antenna.
- Increase the separation between the equipment and receiver.
- Connect the equipment into an outlet on a circuit different from that to which the receiver is connected.
- Consult the dealer or an experienced radio/TV technician for help.

3.2 Canada

3.2.1 For EVMs issued with an Industry Canada Certificate of Conformance to RSS-210 or RSS-247

Concerning EVMs Including Radio Transmitters:

This device complies with Industry Canada license-exempt RSSs. Operation is subject to the following two conditions:

(1) this device may not cause interference, and (2) this device must accept any interference, including interference that may cause undesired operation of the device.

Concernant les EVMs avec appareils radio:

Le présent appareil est conforme aux CNR d'Industrie Canada applicables aux appareils radio exempts de licence. L'exploitation est autorisée aux deux conditions suivantes: (1) l'appareil ne doit pas produire de brouillage, et (2) l'utilisateur de l'appareil doit accepter tout brouillage radioélectrique subi, même si le brouillage est susceptible d'en compromettre le fonctionnement.

Concerning EVMs Including Detachable Antennas:

Under Industry Canada regulations, this radio transmitter may only operate using an antenna of a type and maximum (or lesser) gain approved for the transmitter by Industry Canada. To reduce potential radio interference to other users, the antenna type and its gain should be so chosen that the equivalent isotropically radiated power (e.i.r.p.) is not more than that necessary for successful communication. This radio transmitter has been approved by Industry Canada to operate with the antenna types listed in the user guide with the maximum permissible gain and required antenna impedance for each antenna type indicated. Antenna types not included in this list, having a gain greater than the maximum gain indicated for that type, are strictly prohibited for use with this device.

Concernant les EVMs avec antennes détachables

Conformément à la réglementation d'Industrie Canada, le présent émetteur radio peut fonctionner avec une antenne d'un type et d'un gain maximal (ou inférieur) approuvé pour l'émetteur par Industrie Canada. Dans le but de réduire les risques de brouillage radioélectrique à l'intention des autres utilisateurs, il faut choisir le type d'antenne et son gain de sorte que la puissance isotrope rayonnée équivalente (p.i.r.e.) ne dépasse pas l'intensité nécessaire à l'établissement d'une communication satisfaisante. Le présent émetteur radio a été approuvé par Industrie Canada pour fonctionner avec les types d'antenne énumérés dans le manuel d'usage et ayant un gain admissible maximal et l'impédance requise pour chaque type d'antenne. Les types d'antenne non inclus dans cette liste, ou dont le gain est supérieur au gain maximal indiqué, sont strictement interdits pour l'exploitation de l'émetteur.

3.3 Japan

3.3.1 *Notice for EVMs delivered in Japan:* Please see http://www.tij.co.jp/lstds/ti_ja/general/eStore/notice_01.page 日本国内に輸入される評価用キット、ボードについては、次のところをご覧ください。

<https://www.ti.com/ja-jp/legal/notice-for-evaluation-kits-delivered-in-japan.html>

3.3.2 *Notice for Users of EVMs Considered "Radio Frequency Products" in Japan:* EVMs entering Japan may not be certified by TI as conforming to Technical Regulations of Radio Law of Japan.

If User uses EVMs in Japan, not certified to Technical Regulations of Radio Law of Japan, User is required to follow the instructions set forth by Radio Law of Japan, which includes, but is not limited to, the instructions below with respect to EVMs (which for the avoidance of doubt are stated strictly for convenience and should be verified by User):

1. Use EVMs in a shielded room or any other test facility as defined in the notification #173 issued by Ministry of Internal Affairs and Communications on March 28, 2006, based on Sub-section 1.1 of Article 6 of the Ministry's Rule for Enforcement of Radio Law of Japan,
2. Use EVMs only after User obtains the license of Test Radio Station as provided in Radio Law of Japan with respect to EVMs, or
3. Use of EVMs only after User obtains the Technical Regulations Conformity Certification as provided in Radio Law of Japan with respect to EVMs. Also, do not transfer EVMs, unless User gives the same notice above to the transferee. Please note that if User does not follow the instructions above, User will be subject to penalties of Radio Law of Japan.

【無線電波を送信する製品の開発キットをお使いになる際の注意事項】 開発キットの中には技術基準適合証明を受けていないものがあります。技術適合証明を受けていないものご使用に際しては、電波法遵守のため、以下のいずれかの措置を取っていただく必要がありますのでご注意ください。

1. 電波法施行規則第6条第1項第1号に基づく平成18年3月28日総務省告示第173号で定められた電波暗室等の試験設備でご使用いただく。
2. 実験局の免許を取得後ご使用いただく。
3. 技術基準適合証明を取得後ご使用いただく。

なお、本製品は、上記の「ご使用にあたっての注意」を譲渡先、移転先に通知しない限り、譲渡、移転できないものとします。

上記を遵守頂けない場合は、電波法の罰則が適用される可能性があることをご留意ください。日本テキサス・イ

ンスツルメンツ株式会社

東京都新宿区西新宿 6 丁目 2 4 番 1 号

西新宿三井ビル

3.3.3 *Notice for EVMs for Power Line Communication:* Please see http://www.tij.co.jp/lstds/ti_ja/general/eStore/notice_02.page

電力線搬送波通信についての開発キットをお使いになる際の注意事項については、次のところをご覧ください。 <https://www.ti.com/ja-jp/legal/notice-for-evaluation-kits-for-power-line-communication.html>

3.4 European Union

3.4.1 *For EVMs subject to EU Directive 2014/30/EU (Electromagnetic Compatibility Directive):*

This is a class A product intended for use in environments other than domestic environments that are connected to a low-voltage power-supply network that supplies buildings used for domestic purposes. In a domestic environment this product may cause radio interference in which case the user may be required to take adequate measures.

-
4. *EVM Use Restrictions and Warnings:*
 - 4.1 EVMS ARE NOT FOR USE IN FUNCTIONAL SAFETY AND/OR SAFETY CRITICAL EVALUATIONS, INCLUDING BUT NOT LIMITED TO EVALUATIONS OF LIFE SUPPORT APPLICATIONS.
 - 4.2 User must read and apply the user guide and other available documentation provided by TI regarding the EVM prior to handling or using the EVM, including without limitation any warning or restriction notices. The notices contain important safety information related to, for example, temperatures and voltages.
 - 4.3 *Safety-Related Warnings and Restrictions:*
 - 4.3.1 User shall operate the EVM within TI's recommended specifications and environmental considerations stated in the user guide, other available documentation provided by TI, and any other applicable requirements and employ reasonable and customary safeguards. Exceeding the specified performance ratings and specifications (including but not limited to input and output voltage, current, power, and environmental ranges) for the EVM may cause personal injury or death, or property damage. If there are questions concerning performance ratings and specifications, User should contact a TI field representative prior to connecting interface electronics including input power and intended loads. Any loads applied outside of the specified output range may also result in unintended and/or inaccurate operation and/or possible permanent damage to the EVM and/or interface electronics. Please consult the EVM user guide prior to connecting any load to the EVM output. If there is uncertainty as to the load specification, please contact a TI field representative. During normal operation, even with the inputs and outputs kept within the specified allowable ranges, some circuit components may have elevated case temperatures. These components include but are not limited to linear regulators, switching transistors, pass transistors, current sense resistors, and heat sinks, which can be identified using the information in the associated documentation. When working with the EVM, please be aware that the EVM may become very warm.
 - 4.3.2 EVMs are intended solely for use by technically qualified, professional electronics experts who are familiar with the dangers and application risks associated with handling electrical mechanical components, systems, and subsystems. User assumes all responsibility and liability for proper and safe handling and use of the EVM by User or its employees, affiliates, contractors or designees. User assumes all responsibility and liability to ensure that any interfaces (electronic and/or mechanical) between the EVM and any human body are designed with suitable isolation and means to safely limit accessible leakage currents to minimize the risk of electrical shock hazard. User assumes all responsibility and liability for any improper or unsafe handling or use of the EVM by User or its employees, affiliates, contractors or designees.
 - 4.4 User assumes all responsibility and liability to determine whether the EVM is subject to any applicable international, federal, state, or local laws and regulations related to User's handling and use of the EVM and, if applicable, User assumes all responsibility and liability for compliance in all respects with such laws and regulations. User assumes all responsibility and liability for proper disposal and recycling of the EVM consistent with all applicable international, federal, state, and local requirements.
 5. *Accuracy of Information:* To the extent TI provides information on the availability and function of EVMs, TI attempts to be as accurate as possible. However, TI does not warrant the accuracy of EVM descriptions, EVM availability or other information on its websites as accurate, complete, reliable, current, or error-free.
 6. *Disclaimers:*
 - 6.1 EXCEPT AS SET FORTH ABOVE, EVMS AND ANY MATERIALS PROVIDED WITH THE EVM (INCLUDING, BUT NOT LIMITED TO, REFERENCE DESIGNS AND THE DESIGN OF THE EVM ITSELF) ARE PROVIDED "AS IS" AND "WITH ALL FAULTS." TI DISCLAIMS ALL OTHER WARRANTIES, EXPRESS OR IMPLIED, REGARDING SUCH ITEMS, INCLUDING BUT NOT LIMITED TO ANY EPIDEMIC FAILURE WARRANTY OR IMPLIED WARRANTIES OF MERCHANTABILITY OR FITNESS FOR A PARTICULAR PURPOSE OR NON-INFRINGEMENT OF ANY THIRD PARTY PATENTS, COPYRIGHTS, TRADE SECRETS OR OTHER INTELLECTUAL PROPERTY RIGHTS.
 - 6.2 EXCEPT FOR THE LIMITED RIGHT TO USE THE EVM SET FORTH HEREIN, NOTHING IN THESE TERMS SHALL BE CONSTRUED AS GRANTING OR CONFERRING ANY RIGHTS BY LICENSE, PATENT, OR ANY OTHER INDUSTRIAL OR INTELLECTUAL PROPERTY RIGHT OF TI, ITS SUPPLIERS/LICENSORS OR ANY OTHER THIRD PARTY, TO USE THE EVM IN ANY FINISHED END-USER OR READY-TO-USE FINAL PRODUCT, OR FOR ANY INVENTION, DISCOVERY OR IMPROVEMENT, REGARDLESS OF WHEN MADE, CONCEIVED OR ACQUIRED.
 7. *USER'S INDEMNITY OBLIGATIONS AND REPRESENTATIONS.* USER WILL DEFEND, INDEMNIFY AND HOLD TI, ITS LICENSORS AND THEIR REPRESENTATIVES HARMLESS FROM AND AGAINST ANY AND ALL CLAIMS, DAMAGES, LOSSES, EXPENSES, COSTS AND LIABILITIES (COLLECTIVELY, "CLAIMS") ARISING OUT OF OR IN CONNECTION WITH ANY HANDLING OR USE OF THE EVM THAT IS NOT IN ACCORDANCE WITH THESE TERMS. THIS OBLIGATION SHALL APPLY WHETHER CLAIMS ARISE UNDER STATUTE, REGULATION, OR THE LAW OF TORT, CONTRACT OR ANY OTHER LEGAL THEORY, AND EVEN IF THE EVM FAILS TO PERFORM AS DESCRIBED OR EXPECTED.
-

8. *Limitations on Damages and Liability:*

8.1 *General Limitations.* IN NO EVENT SHALL TI BE LIABLE FOR ANY SPECIAL, COLLATERAL, INDIRECT, PUNITIVE, INCIDENTAL, CONSEQUENTIAL, OR EXEMPLARY DAMAGES IN CONNECTION WITH OR ARISING OUT OF THESE TERMS OR THE USE OF THE EVMS , REGARDLESS OF WHETHER TI HAS BEEN ADVISED OF THE POSSIBILITY OF SUCH DAMAGES. EXCLUDED DAMAGES INCLUDE, BUT ARE NOT LIMITED TO, COST OF REMOVAL OR REINSTALLATION, ANCILLARY COSTS TO THE PROCUREMENT OF SUBSTITUTE GOODS OR SERVICES, RETESTING, OUTSIDE COMPUTER TIME, LABOR COSTS, LOSS OF GOODWILL, LOSS OF PROFITS, LOSS OF SAVINGS, LOSS OF USE, LOSS OF DATA, OR BUSINESS INTERRUPTION. NO CLAIM, SUIT OR ACTION SHALL BE BROUGHT AGAINST TI MORE THAN TWELVE (12) MONTHS AFTER THE EVENT THAT GAVE RISE TO THE CAUSE OF ACTION HAS OCCURRED.

8.2 *Specific Limitations.* IN NO EVENT SHALL TI'S AGGREGATE LIABILITY FROM ANY USE OF AN EVM PROVIDED HEREUNDER, INCLUDING FROM ANY WARRANTY, INDEMNITY OR OTHER OBLIGATION ARISING OUT OF OR IN CONNECTION WITH THESE TERMS, , EXCEED THE TOTAL AMOUNT PAID TO TI BY USER FOR THE PARTICULAR EVM(S) AT ISSUE DURING THE PRIOR TWELVE (12) MONTHS WITH RESPECT TO WHICH LOSSES OR DAMAGES ARE CLAIMED. THE EXISTENCE OF MORE THAN ONE CLAIM SHALL NOT ENLARGE OR EXTEND THIS LIMIT.

9. *Return Policy.* Except as otherwise provided, TI does not offer any refunds, returns, or exchanges. Furthermore, no return of EVM(s) will be accepted if the package has been opened and no return of the EVM(s) will be accepted if they are damaged or otherwise not in a resalable condition. If User feels it has been incorrectly charged for the EVM(s) it ordered or that delivery violates the applicable order, User should contact TI. All refunds will be made in full within thirty (30) working days from the return of the components(s), excluding any postage or packaging costs.

10. *Governing Law:* These terms and conditions shall be governed by and interpreted in accordance with the laws of the State of Texas, without reference to conflict-of-laws principles. User agrees that non-exclusive jurisdiction for any dispute arising out of or relating to these terms and conditions lies within courts located in the State of Texas and consents to venue in Dallas County, Texas. Notwithstanding the foregoing, any judgment may be enforced in any United States or foreign court, and TI may seek injunctive relief in any United States or foreign court.

Mailing Address: Texas Instruments, Post Office Box 655303, Dallas, Texas 75265
Copyright © 2023, Texas Instruments Incorporated

IMPORTANT NOTICE AND DISCLAIMER

TI PROVIDES TECHNICAL AND RELIABILITY DATA (INCLUDING DATASHEETS), DESIGN RESOURCES (INCLUDING REFERENCE DESIGNS), APPLICATION OR OTHER DESIGN ADVICE, WEB TOOLS, SAFETY INFORMATION, AND OTHER RESOURCES "AS IS" AND WITH ALL FAULTS, AND DISCLAIMS ALL WARRANTIES, EXPRESS AND IMPLIED, INCLUDING WITHOUT LIMITATION ANY IMPLIED WARRANTIES OF MERCHANTABILITY, FITNESS FOR A PARTICULAR PURPOSE OR NON-INFRINGEMENT OF THIRD PARTY INTELLECTUAL PROPERTY RIGHTS.

These resources are intended for skilled developers designing with TI products. You are solely responsible for (1) selecting the appropriate TI products for your application, (2) designing, validating and testing your application, and (3) ensuring your application meets applicable standards, and any other safety, security, regulatory or other requirements.

These resources are subject to change without notice. TI grants you permission to use these resources only for development of an application that uses the TI products described in the resource. Other reproduction and display of these resources is prohibited. No license is granted to any other TI intellectual property right or to any third party intellectual property right. TI disclaims responsibility for, and you fully indemnify TI and its representatives against any claims, damages, costs, losses, and liabilities arising out of your use of these resources.

TI's products are provided subject to [TI's Terms of Sale](#), [TI's General Quality Guidelines](#), or other applicable terms available either on ti.com or provided in conjunction with such TI products. TI's provision of these resources does not expand or otherwise alter TI's applicable warranties or warranty disclaimers for TI products. Unless TI explicitly designates a product as custom or customer-specified, TI products are standard, catalog, general purpose devices.

TI objects to and rejects any additional or different terms you may propose.

Copyright © 2026, Texas Instruments Incorporated

Last updated 10/2025